



**Blackhawk
Automotive**™

Blackhawk Automotive is a Licensed Trade Mark

Made by SFA Companies, Kansas City, MO

Service Jack Combo

Operating Instructions & Parts Manual

Model
BH6032

Capacity
3 Ton



This is the safety alert symbol. It is used to alert you to potential personal injury hazards. Obey all safety messages that follow this symbol to avoid possible injury or death.

ADVERTENCIA

- Leer, comprender, y seguir las instrucciones antes de utilizar el aparato.
- El manual de instrucciones y la información de seguridad deben estar comunicado en lengua del operador antes del uso.
- No seguir estas indicaciones puede causar daños personales o materiales.

WARNING

To avoid **crushing and related injuries**:



NEVER work on, under or around a load supported only by a hydraulic jack. **ALWAYS** use adequately rated jack stands.

SFA Companies
10939 N. Pomona Ave. Kansas City, MO 64153
sales@blackhawk-automotive.com

Read this manual and follow all the Safety Rules and Operating Instructions before using this product.

Made in PRC
BH6032-M0 11/07

SAFETY and GENERAL INFORMATION

Save these instructions. For your safety, read, understand, and follow the information provided with and on this product before using. The owner and operator of this product shall have an understanding of this product and safe operating procedures before attempting to use. The owner and operator shall be aware that use and repair of this product may require special skills and knowledge. Instructions and safety information shall be conveyed in the operator's native language before use of this product is authorized. If any doubt exists as to the safe and proper use of this product, remove from service immediately.

Inspect before each use. Do not use if broken, bent, cracked or damaged parts are noted. Any jack or jack stand that appears damaged in any way, or operates abnormally shall be removed from service immediately. If the jack or jack stand has been or suspected to have been subjected to a shock load (a load dropped suddenly, unexpectedly upon it), immediately discontinue use until jack has been checked by a factory authorized service center (contact distributor or manufacturer for list of authorized service centers). It is recommended that an annual inspection be done by qualified personnel. Labels and Operator's Manuals are available from manufacturer.

Important: Any **jack stand** that appears to be damaged in any way, is worn or operated abnormally shall be removed from service and destroyed immediately. No repair shall be made to a jack stand. Replace jack stands as a matched set. No user serviceable parts are available.

PRODUCT DESCRIPTION

Service Jack is designed to lift, but not support, one end of a vehicle. Immediately after lifting, loads must be supported by a pair of appropriately rated jack stands. This Fast Lift Service Jack has a unique feature that provides fast, no load lifts to the jacking point, no load lifts to the jacking point, at which time it lifts in approximately 0.75~2" increments.

! **NEVER** use hydraulic jack as stand-alone device. After lifting, **immediately** support the lifted vehicle with a pair of appropriately rated jack stands.

Jack Stands are designed to support rated capacity, partial vehicle loads consisting of one end of a vehicle. Use as a matched pair to support one end of a vehicle only.

! **NEVER** use automotive jack stands to support **both ends** or **one side** of a vehicle!
Use only **one (1) pair** per vehicle. Rated capacity is **per pair** only!

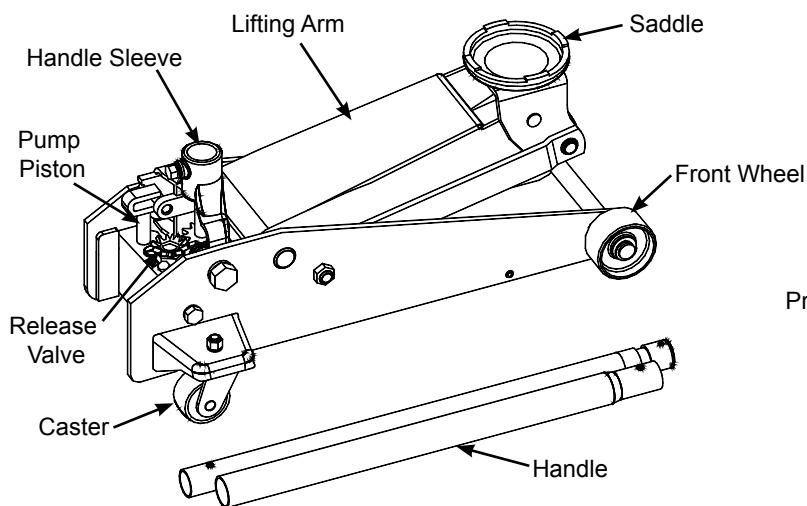

Figure 1 - Service Jack Components

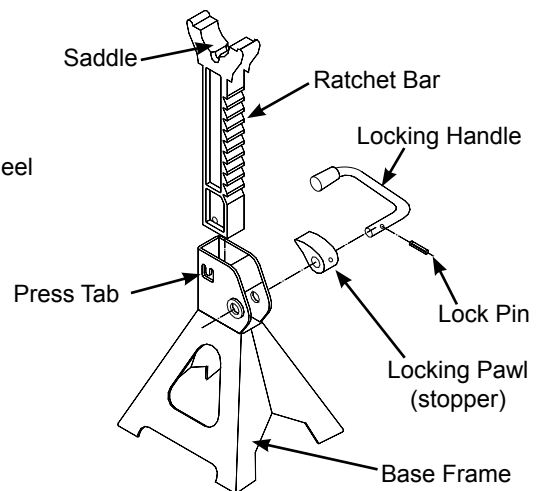

Figure 2 - Jack Stands Components

SPECIFICATIONS

Service Jack:

Capacity	Min. Height	Max. Height	Saddle Diameter	Jack Size (L x W x H)	Volume of Hyd. Oil	Net Weight
3 Ton	5 1/4"	20 7/8"	5"	27 1/8" x 13 3/8" x 6 3/4"	245mL	78 lb.

Jack Stands:

Capacity	Min. Height	Max. Height	Saddle Size	Base Size (L x W)	Net Weight
3 Ton	11 1/2"	17"	3 1/2" x 1"	6 3/4" x 7 3/4"	14.1 lb.

PREPARATION

Assembly

Make sure all parts are present (refer Fig. 1 & 2). If any parts is missing or damage, do not attempt to assemble, install or operate the product. Contact Customer service.

A. Service Jack:

1. Attach the 2-pc handle with bolt provided on the handle.
2. Secure the assembled handle into handle sleeve with provided bolt. Tighten securely to prevent accidental removal of handle while in use.

B. Jack Stands:

Tools required: Hammer and Punch (not included)

1. Install ratchet bar into base frame with ratchet portion of bar aligned with locking pawl.
2. Move the ratchet bar to its lowest position by raising the locking handle, thereby releasing the stopper and guiding the bar downward.
3. Ratchet/ collar lock is accomplished by simply pressing the press tab (see Fig. 2) inward using a suitable hammer and punch. This will effectively prevent inadvertent loss of the ratchet bar.

Before Use

1. Verify that the product and application are compatible, if in doubt call Blackhawk Tech. Service (816) 891-6390.
2. Before using this product, read the operator's manual completely and familiarize yourself thoroughly with the product, its components and recognize the hazards associated with its use.
3. Inspect before each use. Do not use if there are bent, broken or cracked components noted.
4. Always check the vehicle owner's or service manual for location of proper lift and support points.

Service Jack:

5. To familiarize yourself with basic operation of service jack, locate and turn the release valve (handle):
 - a. Clockwise until firm resistance is felt to further turning. This is the '**CLOSED**' release valve position used to **raise** the saddle.
 - b. Counter-clockwise, but no more than 1/2 turn from the closed position. This is the '**OPEN**' release valve position used to **lower** the saddle.
6. With saddle fully lowered, remove the oil filler screw. Pump 6 to 8 full strokes. This will help release any pressurized air which may be trapped within the reservoir. Check oil level. Proper oil level will vary from just covering the ram cylinder to 3/16" above it as seen from the oil filler hole. Reinstall the oil filler screw.
7. Ensure that jack rolls freely. Raise and lower the unloaded saddle throughout the lifting range before putting into service to ensure the pump operates smoothly. Replace worn or damaged parts and assemblies with Blackhawk Automotive authorized replacement parts only.

Bleeding / Venting Trapped Air of a Service Jack

With the release valve in the OPEN position (5b.) and with saddle fully lowered, locate and remove the oil filler screw. Pump 6 to 8 full strokes. This will help release any pressurized air which may be trapped within the reservoir. Reinstall the oil filler screw.

WARNING

- **Study, understand, and follow** all printed materials provided with/on this product **before use**.
- Use **only** on hard, level surface.
- **Do not** exceed rated capacity.
- Lift and support **only** on areas of the vehicle as specified by the vehicle manufacturer.
- Center load on saddle.
- No alterations shall be made to this product.

SERVICE JACK:

- **This is a lifting device only!**
- **Immediately** after lifting, support the load with a **pair** of appropriately rated jack stands.
- Do not move or dolly the vehicle while on the jack.

JACK STANDS:

- Rated capacity of **jack stands** is **PER PAIR!**
- Use as a matched pair to support one end of a vehicle only. Use only **ONE (1) PAIR** per vehicle.
- Jack stands are not to be used to simultaneously support both ends or one side of a vehicle.

**FAILURE TO HEED THESE MARKINGS MAY
RESULT IN PERSONAL INJURY AND/OR
PROPERTY DAMAGE**

WARNING

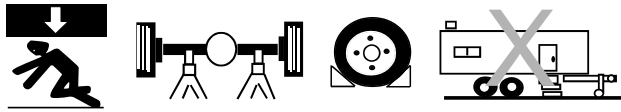

To avoid **crushing and related injuries**:

- **Never** work on, under or around a load supported only by hydraulic jack.
- **Always** use adequately rated jack stands.
- Chock each unlifted tire in both directions.
- **Do not** use this device to lift, level, lower, support nor move a house, mobile home, travel trailer, camper or any building structure.
- **Be alert and sober** when using this product. Do not operate under the influence of drugs or alcohol.

OPERATION

Lifting



Only attachments and/or adapters supplied by the manufacturer shall be used.



*Use **jack stands only** on areas of the vehicle as specified by the vehicle manufacturer. Use **ONLY** on vehicles whose support points are **compatible** with the saddle of the jack stand. Incompatibility may result in structural damage to the vehicle and/or jack stand. Structural damage to either may result in sudden and unexpected loss of load height!*

1. Follow vehicle manufacturer's recommended guidelines for lifting. Engage the emergency brake and chock each unlifted wheel in both directions to prevent inadvertent vehicle movement.
2. Set up jack stands:
 - a. Adjust height by pulling up the ratchet bar.
 - b. The weight of locking handle should secure the ratchet bar in desired position. To confirm this, Simply push down on the locking handle.
3. Close release valve by turning the handle clockwise until firm resistance is felt.
4. Verify lift point, then center jack saddle under lift point. Pump handle to contact lift point. To lift, pump handle until load reaches desired height.
5. Transfer load **immediately** to a pair of jack stands:
 - a. *Carefully* position the stands so that load is centered on the saddle. Ensure that ratchet is secured before loading.
 - b. *Slowly* lower the vehicle onto stands. Ensure the vehicle is secured before working on, around or under.



***NEVER** use hydraulic jack as a stand alone device! **ALWAYS** transfer the lifted load **IMMEDIATELY** to a pair of appropriately rated jack stands.*

Lowering



*Be sure all tools and personnel are clear before lowering load. **Slowly open the release valve!** The more you turn the handle counter-clockwise, the faster the load will come down. **Maintain control** of the rate of speed at which the load lowers at all times!*

1. Raise vehicle high enough to clear the jack stands.
2. Remove jack stands carefully.
3. **Slowly** turn the handle counter-clockwise, but no more than 1/2 full turn. If the load fails to lower:
 - a. Use another jack to raise the vehicle high enough to reinstall jack stands.
 - b. Remove malfunctioning jack, then the jack stands.
 - c. Use the functioning jack to lower the vehicle
4. After removing jack from under the vehicle, fully lower the saddle to reduce ram exposure to rust and contamination.

MAINTENANCE

A. Service Jack:

Important: Use **ONLY** good grade hydraulic jack oil. Avoid mixing different types of fluid and **Never** use brake fluid, turbine oil, transmission fluid, motor oil or glycerin. Improper fluid can cause failure of the jack and the potential for sudden and immediate loss of load. We recommend Hein-Werner HW93291 or equivalent.

Adding oil

1. With saddle fully lowered set jack in its upright, level position. Locate and remove oil filler screw.
2. Fill with oil until ~3/16" above the inner cylinder as seen from the oil filler hole. Reinstall the oil filler screw.

Changing oil

For best performance, replace the complete fluid supply at least once per year.

1. With saddle fully lowered, remove oil filler screw.
2. Lay the jack on its side and drain the fluid into a suitable container.

Note: Dispose of hydraulic fluid in accordance with local regulations.

3. Fill with oil until ~3/16" above the inner cylinder as seen from the oil filler hole. Reinstall oil filler screw.

Lubrication

A periodic coating of light lubricating oil to pivot points, axles and hinges will help to prevent rust and assure that wheels, casters and pump assemblies move freely.

Cleaning

Periodically check pump piston and ram for signs of rust or corrosion. Clean as needed and wipe with an oily cloth.

Note: Never use sandpaper or abrasive material on these surfaces!

Storage

When not in use, store the jack with saddle fully lowered.

B. Jack Stands:

Periodically inspect each stand. Ensure all parts move freely. Do not apply oil or grease to any portion of this product. If rust appears, sand affected area and cover with suitable utility paint. Please note that there is no replacement part applicable to this device.

Storage

Store stands in upright position and in a clean, dry area.

TROUBLESHOOTING

Symptom	Possible Causes	Corrective Action
Jack will not lift load	<ul style="list-style-type: none">• Release valve not tightly closed• Load is too heavy	<ul style="list-style-type: none">• Ensure release valve tightly closed• Consider higher capacity jack
Jack will lift, but not maintain pressure	<ul style="list-style-type: none">• Release valve not tightly closed• Hydraulic unit malfunction	<ul style="list-style-type: none">• Ensure release valve tightly closed• Discontinue use, contact Blackhawk Automotive technical service
Jack will not lower after unloading	<ul style="list-style-type: none">• Reservoir overfilled• Linkages binding• Fluid level low	<ul style="list-style-type: none">• Drain fluid to proper level• Clean and lubricate moving parts• Ensure proper fluid level
Poor lift performance	<ul style="list-style-type: none">• Fluid level low• Air trapped in system	<ul style="list-style-type: none">• Ensure proper fluid level• With ram fully retracted, remove oil filler screw to let pressurized air escape. Reinstall oil filler screw
Will not lift to full extension	<ul style="list-style-type: none">• Fluid level low	<ul style="list-style-type: none">• Ensure proper fluid level

REPLACEMENT PARTS

Not all components of the jack are replacement items, but are illustrated as a convenient reference of location and position in the assembly sequence. When ordering parts, give Model number, serial number and parts description. Call or write for current pricing: SFA Companies, 10939 N. Pomona Ave. Kansas City, MO 64153, U.S.A. Tel:(816)891-6390 Fax:(816)891-6599 E-Mail: sales@blackhawk-automotive.com

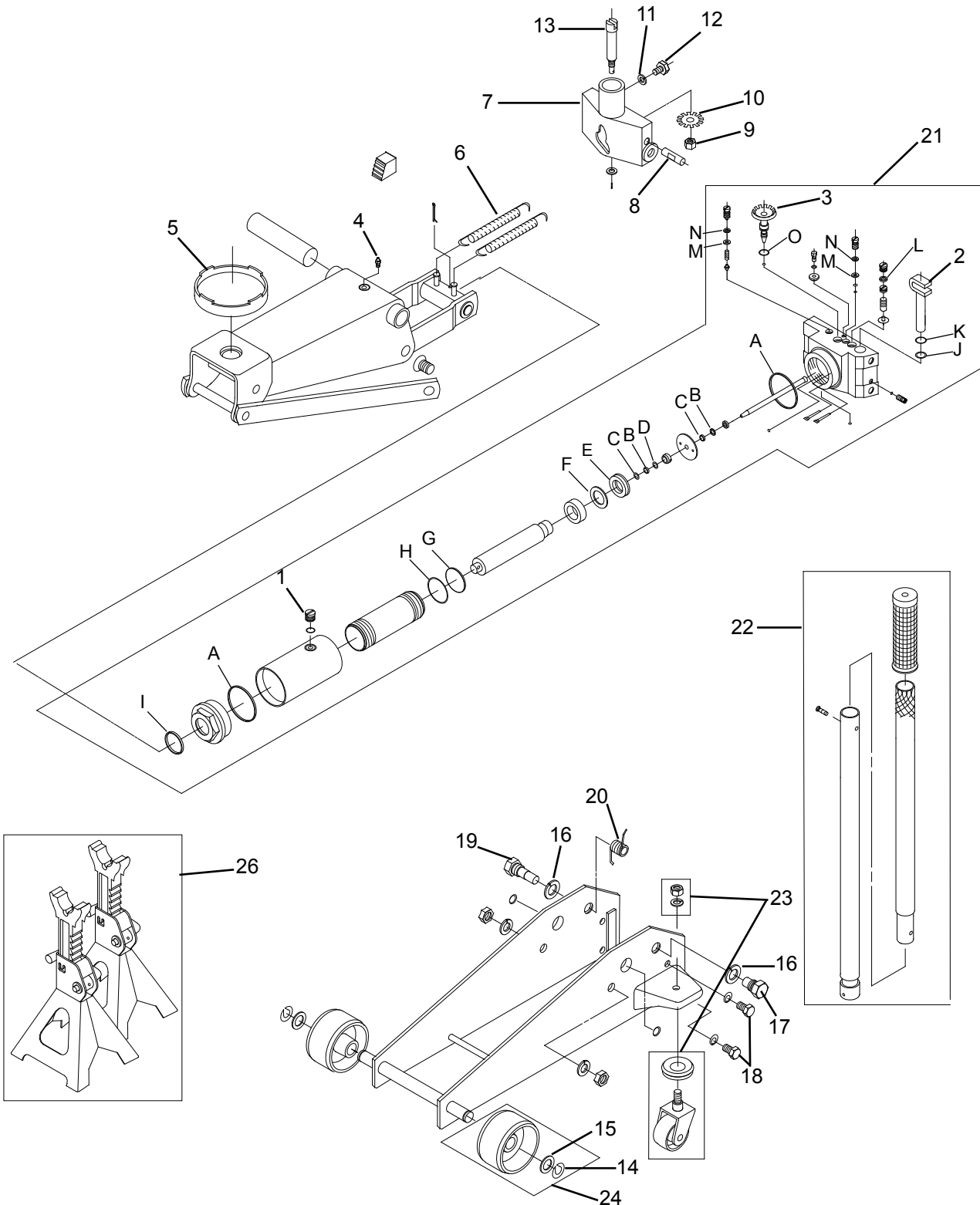

Figure 3 - Replacement Parts Illustration for Model BH6032 Service Jack Combo

Replacement Parts List for model BH6032 Service Jack

Item	Part No.	Description	Qty
1	A20060-0002	Filler Screw	1
2	G48900-0023	Pump Piston	1
3	G48900-0004	Release Valve	1
4	G43000-0002	Grease Fitting Nipple, M6	1
5	G59508-0004	Saddle	1
6	G62000-1003	Return Spring	2
7	G58900-0002	Handle Sleeve	1
8	G48900-0015	Pin, D13	1
9	G59305-0003	Nut M10	1
10	G48900-0016	Release Valve Gear	1
11	G59305-0005	Lock Washer D10	1
12	G48900-0024	Bolt M10x16mm	1
13	G48900-0017	Release Valve Connecting Bar	1
14	G59305-0007	E-ring D15	2
15	G59305-0004	Washer D18	2
16	G59305-0006	Lock Washer D20	2
17	G48900-0018	Handle Bolt, Left	1
18	G48900-0019	Bolt M12	4
19	G48900-0020	Handle Bolt, Right	1
20	G48900-0001	Return Spring, Handle Sleeve	1
21	G43000-0001	Hydraulic Power Unit	1
22	G48900-0003	Handle Assembly	1
23	G69300-0003	Caster Assembly	2
24	G48900-0007	Front Wheel Assembly	2
25	G43000-0000	Seal Kit (includes # A ~ O)	-
26	BH5030	Vehicle Stands, 3 Ton (replace as pair)	1
27	BH6032-L0	Label(s)	-
28	BH6032-M0	Manual	-

Seal Kit G43000-0000 includes:

Item	Description	Qty.
A	O-ring, D63.5x2.8	2
B	O-ring	2
C	Back-up Washer	2
D	Back-up Washer	1
E	U-cup	1
F	Back-up Washer	1
G	O-ring, D44.5x2.5	1
H	Back-up Washer	1
I	O-ring, D38x3.5	1
J	O-ring, D19x2.4	1
K	Back-up Washer	1
L **	O-ring, D8.2x2.4	1
M **	O-ring	2
N **	Back-up Washer	2
O	O-ring, D15x2.4	1

(**) Replacement requires special skills, knowledge, and equipment. Only an authorized service center may perform the repair and/or replacement of these items. Contact Blackhawk technical service for list of service centers.

ONE YEAR LIMITED WARRANTY

For a period of one (1) year from date of purchase, SFA Companies will repair or replace, at its option, without charge, any of its products which fails due to a defect in material or workmanship under normal usage. This limited warranty is a consumer's exclusive remedy.

Performance of any obligation under this warranty may be obtained by returning the warranted product, freight prepaid, to SFA Companies Warranty Service Department, 10939 N. Pomona Ave., Kansas City, MO 64153.

Except where such limitations and exclusions are specifically prohibited by applicable law,

(1) THE CONSUMER'S SOLE AND EXCLUSIVE REMEDY SHALL BE THE REPAIR OR REPLACEMENT OF DEFECTIVE PRODUCTS AS DESCRIBED ABOVE.

(2) SFA Companies SHALL NOT BE LIABLE FOR ANY CONSEQUENTIAL OR INCIDENTAL DAMAGE OR LOSS WHATSOEVER.

(3) ANY IMPLIED WARRANTIES, INCLUDING WITHOUT LIMITATION THE IMPLIED WARRANTIES OF MERCHANTABILITY AND FITNESS FOR A PARTICULAR PURPOSE, SHALL BE LIMITED TO ONE YEAR, OTHERWISE THE REPAIR, REPLACEMENT OR REFUND AS PROVIDED UNDER THIS EXPRESS LIMITED WARRANTY IS THE EXCLUSIVE REMEDY OF THE CONSUMER, AND IS PROVIDED IN LIEU OF ALL OTHER WARRANTIES, EXPRESS OR IMPLIED.

(4) ANY MODIFICATION, ALTERATION, ABUSE, UNAUTHORIZED SERVICE OR ORNAMENTAL DESIGN VOIDS THIS WARRANTY AND IS NOT COVERED BY THIS WARRANTY.

Some states do not allow limitations on how long an implied warranty lasts, so the above limitation may not apply to you. Some states do not allow the exclusion or limitation of incidental or consequential damages, so the above limitation or exclusion may not apply to you. This warranty gives you specific legal rights, and you may also have other rights, which vary from state to state.



SFA Companies
10939 N. Pomona Ave. Kansas City, MO 64153
816-891-6390
sales@blackhawk-automotive.com