

**UNION SWITCH & SIGNAL** 

645 Russell Street  
Batesburg, SC 29006

**Service Manual 6123**

---

# **ADL-256**

**I/O Test Panel**

---

**March, 1978**  
© 1978, Union Switch & Signal Inc.  
Printed in U.S.A.

An **ANSALDO** Affiliated Company

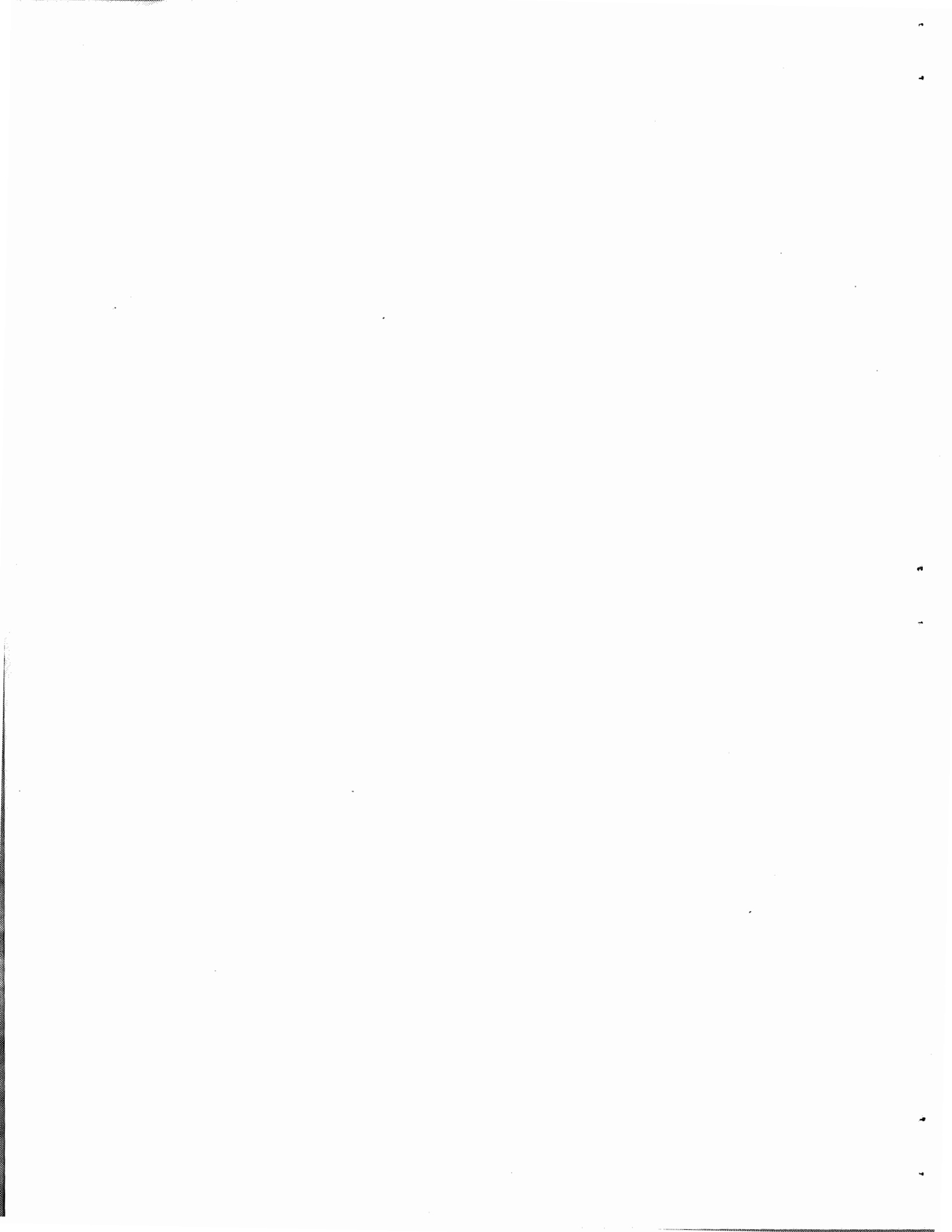



## CIRCUIT NOMENCLATURE AND GRAPHICAL SYMBOLS

### 1. CIRCUIT NOMENCLATURE

The purpose of the following is to explain the scheme of abbreviated designations used for electrically-operated signal units and wires.

Letters suggestive of the words they represent have been assigned as far as practicable but there are some letters that stand for names that cannot be associated, such as "G" for signal and "W" for switch. Some of the letters represent several different meanings or words, such as "N" Normal, "N" Negative, "N" North. Depending upon the use and location with respect to numerals and other letters, but if the scheme is consistently used there should be no mistake in the meaning.

### 2. NOMENCLATURE OF ELECTRICALLY-OPERATED UNITS

The term "Electrically-Operated Unit" is used to signify a signaling device in which an electric light or magnetic coil is usually essential to its operation, as, for instance, color-light signal, a relay, electric lock, etc. in order to provide a concise, suggestive graphic code for marking these units on plans, the following system has been evolved, which makes use of a designation made up of two parts; namely,

First--numerical prefix: the number of the principle lever, signal, track circuit, or other device entering into the control of or controlled by the unit.

Second--alphabetic term: consisting of one or more letters. The last letter of this term designates the general kind of unit, while the first letter or letters, when used, describe specifically the operated unit.

The complete designation of a unit is written as follows:

(Numerical Prefix)	(First Letter)	(Last Letter)
2	H	R

Written 2HR

In this example, 2 is the number of a signal. 2R means relay having to do with signal 2, and 2HR means home relay for signal 2. In other words, the letter R means relay in general. The letter H indicates that the function of this relay is to control the proceed or caution indication of a signal. The number 2 definitely indicates the signal which this relay controls.



### 3. TRACK CIRCUIT NUMBERING

A track circuit is designated by the letter "T" preceded by a number. If within interlocking limits, it will take a number of a movable point frog, switch, or derail lying within the track circuit, the preference being in the order named.

When there are no interlocked switches in a track circuit, it is numbered from a signal governing over the track circuit. Progressive alphabetical prefixes are used in the case of a plurality of track sections that govern one signal.

### 4. WIRE NOMENCLATURE

A wire carrying positive energy to one or more operated units is in general designated by nomenclature similar to that applied to the operated unit controlled by it, followed by a number indicating the number of circuit controlling contacts in the circuit between the wire and unit.

A wire carrying negative energy from one or more operated units is designated in the same manner except that the designation is preceded by the letter "N".



TABLE OF MEANING OF LETTERS  
DESCRIPTIVE AND DESIGNATIVE TERMS

- A - Approach--Alternator--Ampere
- B - Positive Energy--Block--Button
- C - Common--Changer--Call--Coding--Clock--Controller--Correspondence
- D - Proceed indication of a signal--Right position of lever
- E - Electric Light--Exportação--Left Position of lever--Edison--  
Element
- G - Green--Signal (operating mechanism)--Graph
- H - Approach Indication of a Signal--Home
- K - Indicator (Visual)
- L - Locking--Lever--Line
- M - Lockout--Magnetic Marker--Manual
- N - Normal--North--Negative
- O - Off--Overload--On
- P - Power--Repeating--Pole--Polar
- R - Red--Reverse--Relay
- S - South--Stick--Storage--Starting
- T - Track--Time--Transformer--Tower--Transmitter--Train--Tuned
- V - Volt
- W - Switch (Operating Mechanism)
- X - Interlocking--A.C.--Bell
- Y - Yellow
- Z - Use for any special term (to be noted on plan)



## RELAY NOMENCLATURE INDEX

- ANN - Annunciator--provides control for bell and light for highway crossing gateman.
- A - Approach--detects the approach of a train.
- AE - Approach Light--provides signal lighting when a train is approaching.
- AS - Approach Stick--provides the time locking in the switch locking circuit.
- ASPS - Approach Stick--repeater stick of AS and direct repeater. Repeater Stick of RP, used to prevent as cascading.
- ASPSTP - Approach Stick Repeater Stick--repeater of ASPS and T to Track Repeater. Provides additional contact.
- ASPO - Approach Stick--prevents AS from picking up without timing Power Off when A-C power comes on after power interruption.
- ASPOP - Repeater of ASPO.
  
- BK - Block Indication--indicates the presence of a train in the block.
  
- D - Distant--provides green signal control
- DS - Directional Stick--operates for a train movement in a particular direction. (\_\_\_letter denotes direction such as "E" for East.)
  
- EO - Light Flasher--provides flashing light control.
- ES - East Stick--provides detection of an eastbound route.
- EXP - Repeater of ES.
- EXS - East crossing stick--provides release of crossing equipment behind Eastbound train.



Relay Nomenclature Index cont'd.

- G - Signal--signal control.
- GP - Repeater of "G" or signal green repeater.
- GZ - Signal Control--controlled by a control machine signal lever.
- GZP - Repeater of GZ
- GZS - Signal Control Stick--controlled by mechanical lever and control machine lever. Stick circuit maintains relay energized regardless of position of mechanical lever.
- GZBP - Back contact repeater of GZ for additional contacts.
  
- H - Home provides yellow signal control.
- HG - Home Signal--provides yellow control for colorlight signal
- HGP - Repeater of HG.
- HGBPS- Home Signal Back Repeater Stick--provides control machine signal clear indication light.
  
- L - Lock--provides route locking for a switch.
- LBP - Back contact repeater of "L".
- LS - Lock Stick--prevents switch operation when route is locked.
- LSBP - Back contact repeater of LS.
- LK - Lock Indication--provides control machine switch locked indication light and prevents preconditioning of switch lever.
- LO - Light Out--detects burned out signal lamp.
  
- MC - Maintainer Call--control for maintainer call horn.
- MCP - Repeater of MC.
- MCPP - Repeater of MCP.



Relay Nomenclature Index cont'd.

- NWC - Normal Switch Correspondence--indicates that switch point and WZ are in normal position.
- NWCP - Repeater of NWC.
- NWCPP- Repeater of NWCP.
- NWCPPP- Repeater of NWCPP.
- NWZ - Normal Repeater of WZ.
- NWZP - Second Normal Repeater of WZ.
- NLP - Normal Lever Repeater--repeater of normal position of control machine lever.
- NS - North Stick--provides detection of a northbound route.
- NWLP - Normal Switch Lock Repeater--repeats the normal position of a switch circuit controller and electric switch lock.
  
- PBS - Pushbutton Stick--energized by a pushbutton and remains energized after pushbutton returns normal.
- PO - Power Off--transfers power from A-C to D-C when A-C power is off. Control power off indication for CTC.
- POP - Repeater of PO.
  
- RWC - Reverse Switch Correspondence--indicates that switch points and WZ are in the reverse position.
- RWCP - Repeater of RWC.
- RWCPP- Repeater of RWCP.
- RWZ - Reverse repeater of WZ.
- RR - Route Request Relay
- RLP - Reverse Lever Repeater--repeater of reverse position of control machine lever.
- RPR - Route Repeater Relay.





Relay Nomenclature Index cont'd.

- S - Stick--provides detection of a southbound route.  
(   letter denotes direction such as "E" for East.)
  
- T - Track--detects presence of a train on a section of track.
- TP - Repeater of T.
- TPP - Repeater of TP.
- TPPP - Repeater of TPP.
- TE - Time Element--provides time delay.
- TPS - Track Repeater Stick--energized by "T" and a control machine lever contact, will be deenergized by the "T" only.
- TEP - Repeater of TE.
- TPSP - Repeater of TPS.
  
- WS - West Stick--provides detection of a westbound route.
- WSP - Repeater of WS.
- WZ - Switch Control--positioned normal or reverse in response to a control machine switch lever.
- WL - Switch Lock--control for electric switch lock.
- WLA - Switch Lock Approach--provides release for WL.
- WXS - West Crossing Stick--provides release of highway crossing behind a train for a westbound move.
  
- XA - Crossing Approach--detects the approach of a train to a highway crossing.
- XTP - Crossing Track Repeater--highway crossing control.
- XGN - Crossing Gate Normal--detects highway crossing gates in the normal position (Raised).



Relay Nomenclature cont'd.

- XGR - Crossing Gate Reverse--detects highway crossing gate in the reverse position (lowered).
- XGNP - Repeater of XGN.
- XS - Audible Indication--provides control for bell.
- XTS - Crossing Track Stick Relay used at the trap circuit locations.
- XS - Crossing stick relay picks up when train occupies the approach trap circuits location.
- XSPO - Crossing Stick Power Off Relay.
- XSPOP- Repeater of the XSPO.
  
- YP - Yellow Repeater--repeats yellow position of the signal.
- YGP - Yellow Green Repeater--repeats yellow or green position of the signal.
- YGPP - Repeater of YGP.
  
- Z - Function Control--operates in response to a control machine lever.



## MISCELLANEOUS NOMENCLATURE

- B - Number indicates pos. nominal value DC voltage.
- N - Number indicates neg. nominal value DC voltage.
- EB - Positive lamp energy
- EN - Negative lamp energy
- BX\_\_ - A.C. Energy, pos. # indicates nominal voltage
- NX\_\_ - A.C. Energy, neg. # indicates nominal voltage
- RB - Positive Track Relay
- RN - Negative Track Relay
- TB - Positive Track Feed
- TN - Negative Track Feed
- TEL-1 - Telephone
- TEL-2 - Telephone
- MEB - Machine Battery (Mach. Light Battery Pos.?)
- MEN - Machine Negative
- CEB - Machine coded positive energy
- B10-L Line Battery Pos. Energy # indicates nominal volt.
- N10-L Line Battery Neg. Energy

<u>Ref.</u>	<u>Description</u>	<u>Contacts Data</u>	<u>WABCO Pc. No.</u>	<u>Base Pc. No.</u>	<u>Remarks</u>
1	PN-150B Relay	6FB	N322500-701	N334266	Biased Line
2					
3	PN-150BTR Relay	6FB	N322501-701	N334266	1 Ohm Track
4	PN-150BTR Relay	6FB	N322501-701	N334266	4 Ohm Track
5					
6					
7	PN-150BD Relay	3FB-N 3FB-R	N322504-701	N335727	3-Position Line
8	PN-150BH Relay	1FB- 1F-1B	N322511-002	N349904	High Dropaway Trk
9	PN-150BL Relay	3FB	N322510-001	N344874	Light Out
10	PN-150BSR Relay	6FB	N322503-701	N334266	Slow Drop, Line
11					
12	PN-150HD Relay	6FB	N322505-002	N334266	Heavy Duty
13	PN-150N Relay	6FB	N322502-701	N334266	Neutral, Line
14	PN-150P Relay	2FB	N322508-002	N341626	Power Transfer
15					
16					
17					
18	PN-150BM Relay	2F	N322517-001	N376048	Magnetic Blowout
19	PN-150SO Relay	1FB-1B	N322512-001	N372344	Switch Overload
20	PP-151 Relay	GNR	N322516-001	N341785	Mag. Stick, Line
21					
22					
23					
24	PN-250B Relay	6FB- 6F-3B	N322554-701	N373979	Biased, Line
25					
26	PN-258BSR Relay	6FB	N322551-702	N349769	Biased, Slow Release
27					
28	PF-256 Relay	4NR	N322561-701	N384243	Highway Flasher
29					
30					
31	Midtex Relay	4FB	J	J	Non-Vital Mach.
32					
33					
34	KP Relay	4NR	N217122	X253139-001	Final Stick
35	W-400 Transformer	18V 10A	N451428-0106	--	Power Trans.

Ref.	Description	Contacts		Base Pc. No.	Remarks
		Data	WABCO Pc. No.		
36	W-400 Transformer	18V 20A	N451428-0109	--	High Current
37					
38					
39					
40	CCR-4 Rectifier	13.5V	N451372-0101	--	Batt. Charge 4-6C
41					
42	CCR-5 Rectifier	3.0V	N451372-0104	--	Batt. Charge 1-2C
43					
44	CCR-A Rectifier	13.5V	N451372-1301	--	Batt. Charge 6C
45					
46	CCRP-6 Rectifier	30V	N451372-0905	--	Batt. Charge 10-13C
47					
48					
49					
50	Circuit Brkr 6A	250V	J725694-0034	--	Heineman
51	Circuit Brkr 10A	250V	J725694-0035	--	Heineman
52	Circuit Brkr 15A	250V	J725694-0036	--	Heineman
53					
54	Fuse 10 Amp.	250V	J071120	N238637	Cartridge Type
55					
56					
57	Resistor 4.5 <sup>W</sup>	12W	N156683	--	Adj. for lights
58	Resistor 50 <sup>W</sup>		N189956	--	
59	Resistor		N156682	--	
60	Resistor 100 <sup>W</sup>		N239433	--	
61	Resistor 1.2 <sup>W</sup>	12W	N156681	--	Adj. for Trks.
62	Resistor 150 <sup>W</sup>	2W	J721587	--	
63	Resistor 200 <sup>W</sup>	2W	J721161	--	Fixed KP Snub
64	Resistor 3000 <sup>W</sup>	5W	J073841	--	
65	Resistor		N331321		
66					
67					
68					
69	Diode 1N4005	600V	J723568	--	KP Snub
70					
71	Switch	--	J072616	--	
72					
73	Rheostat	--	J620826		
74					
75	Lgt Arrestor	--	N314266	--	Shunt 50V



<u>Ref.</u>	<u>Description</u>	<u>Contacts Data</u>	<u>WABCO Pc. No.</u>	<u>Base Pc. No.</u>	<u>Remarks</u>
76	Lgt Arrestor	--	N327989	N170501	Series 400V
77					
78	Sonalert	2900Hz	J705057	--	Trk #1 Entr.
79	Sonalert	2900Hz	J705057-001	--	Emerg. Indic.
80	Sonalert	4500Hz	J792472	--	Trk #2 Entr.
81					
82	Duplex Receptical	--	J072030	Box J700245 Cover J069834	Grounded Recpt.
83					
84					
85					
86					
87					
88					
89					
90					
91					
92					
93					
94					
95					
96					
97					
98					
99					
100					



# RELAYS DIRECT CURRENT

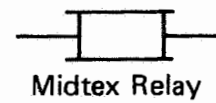
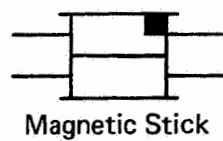
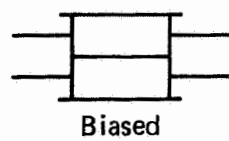
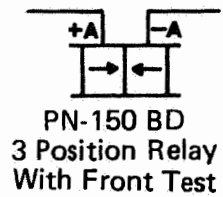
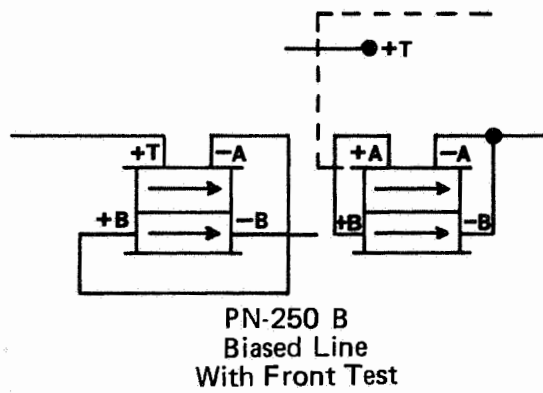
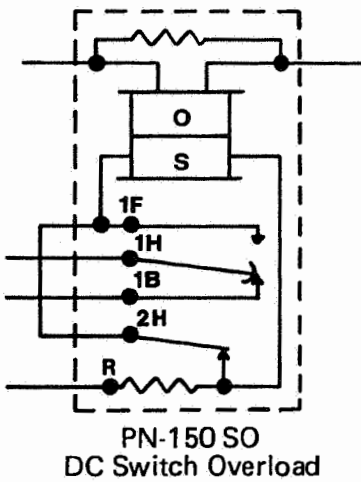
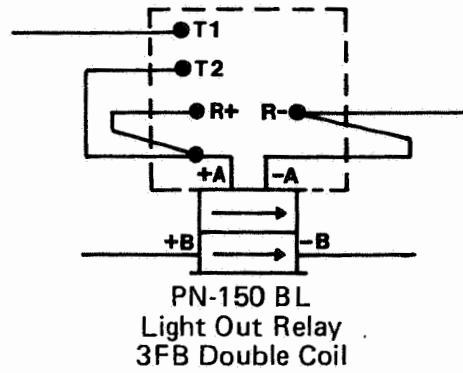
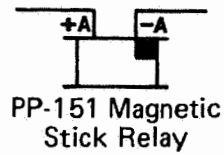

KP Relay

RELAYS  
DIRECT CURRENT

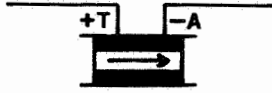

PN-258 BSR  
Biased Slow Release  
Slow Pick Up With  
Front Testing

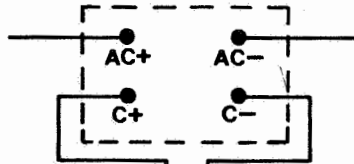

PN-150 P  
Power Off

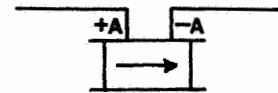

PN-150 B  
Biased Line  
or  
PN-150 BTR  
Biased Track  
With Front Test

PN-150 BM  
Magnetic HD Contact  
With Front Test

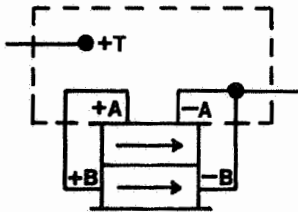

PN-150 BH  
Hi Drop Away Track Relay  
With Front Test

(Coils in Multiple)

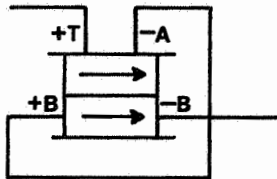

(Coils in Series)

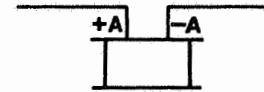

PN-150 HD  
Front Test  
Having Heavy Duty  
Contacts

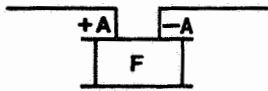

PF-256  
Flasher Relay

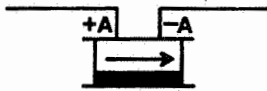

PN-150 BSR  
Slow Drop Away  
With Front Test

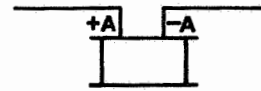

PN-150 N  
Neutral With  
Front Test

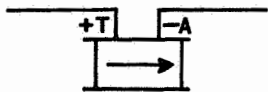

PN-150 BH  
-006  
With Front Test



# RELAY CONTACT ASSIGNMENT

MIDTEX  
Base Contact Assignment

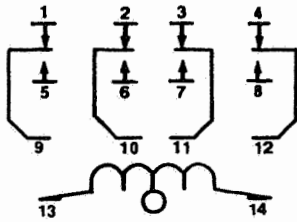
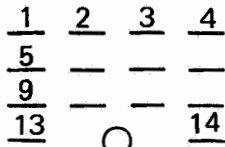

Relay Contact Assignment

## Contact Positions and Contact Symbols for KP Relays

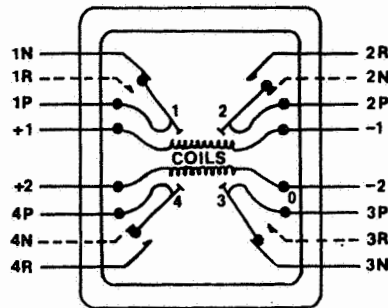

Contact Numbering Viewed From Front

Note: Deenergized Position Of Biased Relay Is With Armature Counterclockwise, Making Reverse Contacts.

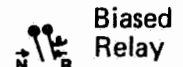

Front & Back Contact Assignment Are Per Following Table

HEEL	FRONT	BACK
9	5	1
10	6	2
11	7	3
12	8	4

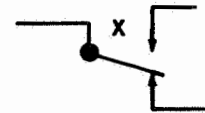

Number "X" Designates Contact Assignment

Example:



Contact No. 1 Implies the Heel Is 1H; Front 1F; the Back 1B.

## RELAY CONTACTS

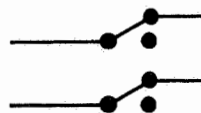
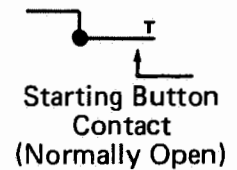
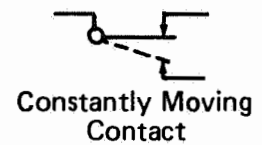
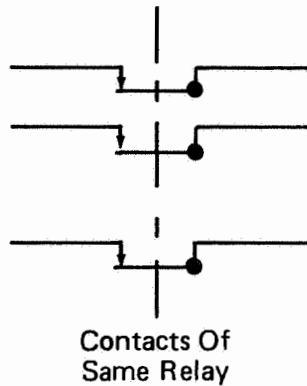
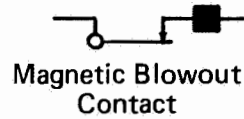
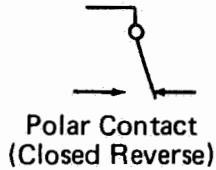
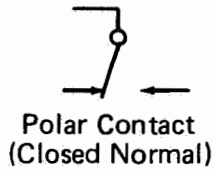
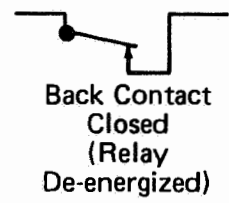
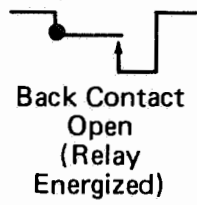
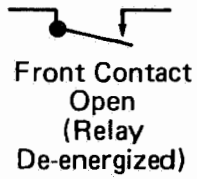
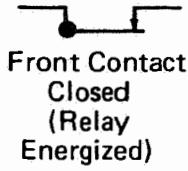

Style U5 Switch Circuit Controller  
Contacts Closed With Switch Reverse  
Contacts Should Be Adjusted To  
Operate When Switch Point Is  $\frac{1}{4}$   
From Normal Position.

## RECTIFIERS

Suffix 0101 CCR-4  
0104 - CCR-5

Suffix 1301 - CCR-A

\* Select Terminals Per Application Requirements



\* Select Terminals Per Application Requirements

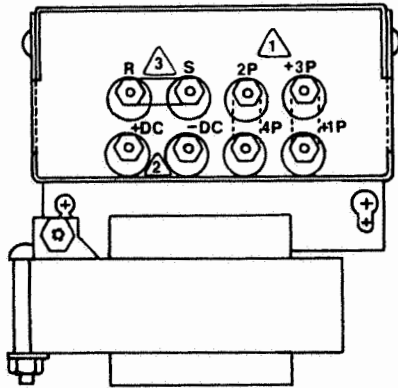
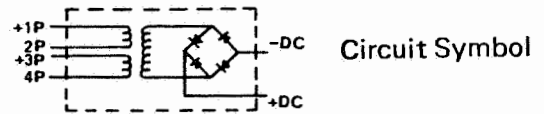

**CORRECTIONS: AC LINE TO +1P & 4P**  
**FOR 120V JUMPER +1P TO +3P,**  
**2P TO 4P**  
**FOR 240V JUMPER +3P TO 2P**

### DIFFERENCE BETWEEN CCR & CCR-A

CCR — provides full-wave rectification & efficient current regulation for battery charging service. Charging current is available from 0 to maximum rated output with two-rate charge capability.

CCR-A — is a self contained full-wave rectifier designed for automatic battery charging service. It has an adjustable high rate & an adjustable low rate of charge & automatically cycles between the two rates. CCR-A contains a solid state control circuit for automatic monitoring of the output voltage and automatic battery charging rate adjustment.

The low charging rate is determined by an external resistor connected across  $R_1$   $R_2$ .

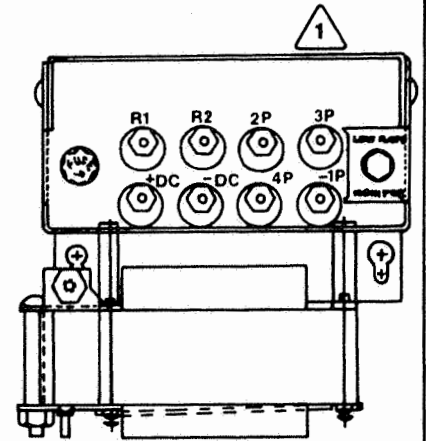

Suffix — 0905

Circuit Symbol

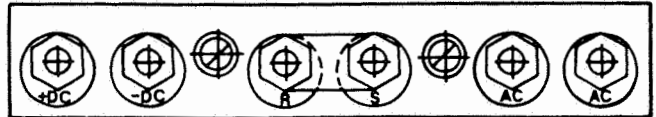
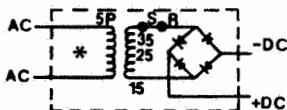

\* Select transformer leads per application requirements. Tape unused leads separately with 3/4 black friction tape (A77358). Tie securely to transformer, with all marking visible.

# M23-A SWITCH MACHINE

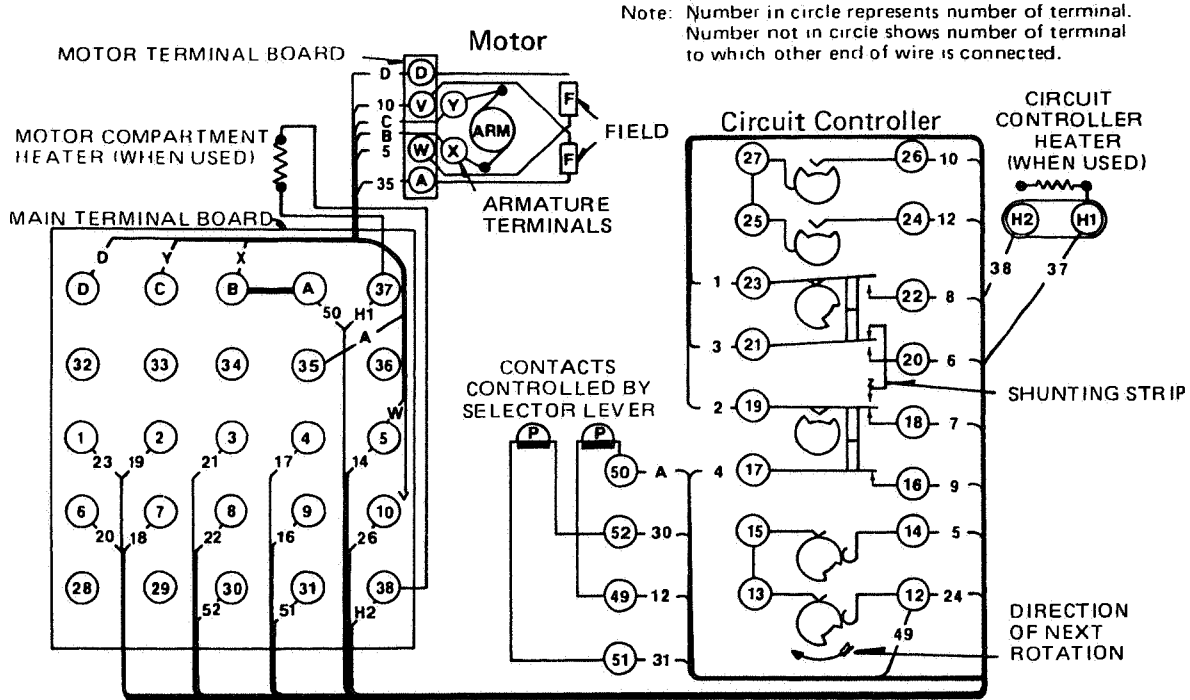

Wiring Diagram For Standard D-C. High-voltage Switch Machine With Split Field Motor.

## TRANSFORMERS

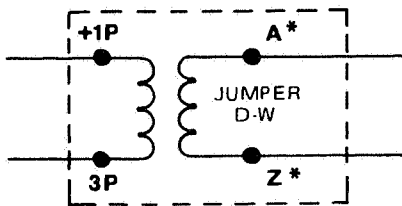

(JUMPER "D" TO "W")  
\* SELECT TERMINALS PER APPLICATION

## TRANSFORMER FACEPLATES

SUFFIX - 0106

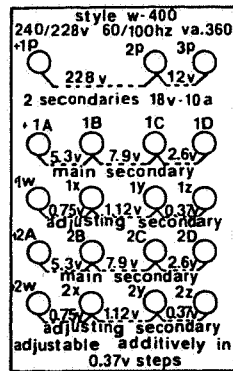

SUFFIX - 0109

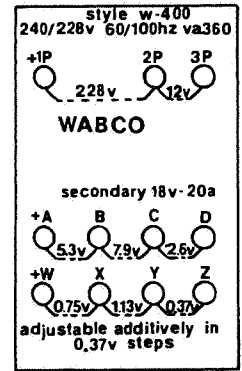

## GRAPHIC SYMBOLS SIGNALS

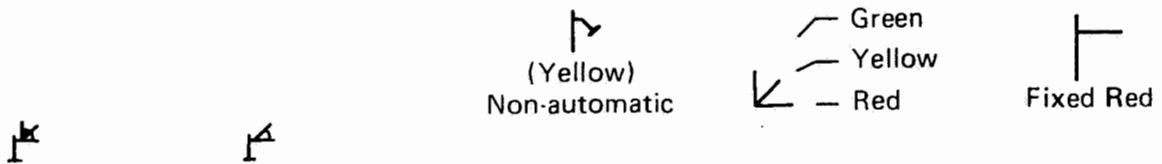
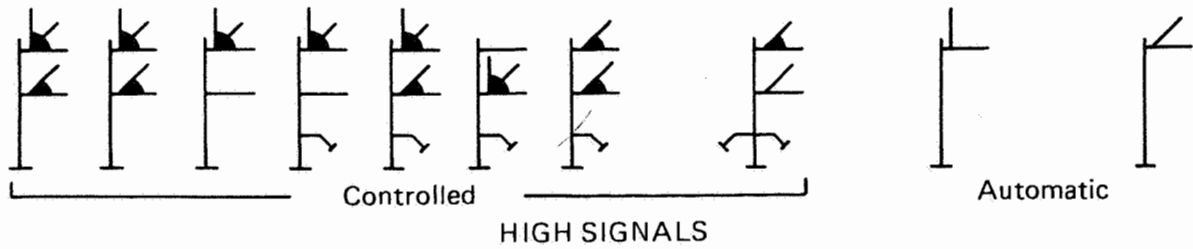

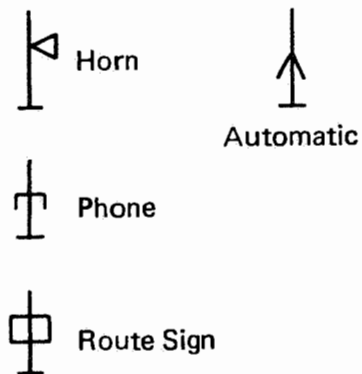

### SIGNAL POLE EQUIPMENT

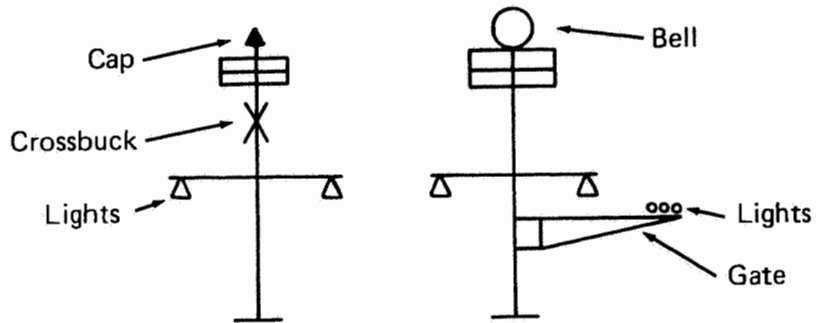

### HIGHWAY CROSSING WARNING EQUIPMENT



 Symbol indicates stick control of signal; restoring of controlling lever to normal position is required before signal can again be cleared for a following train.

 Symbol indicates non-stick control of signal, restoring of controlling lever to normal position is not required before signal can again be cleared for a following train.

### TRACK APPLIANCES

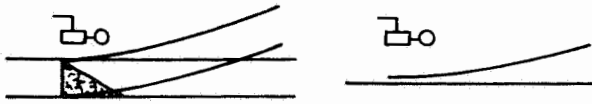

Style M23-A Power  
Switch & Lock Movement

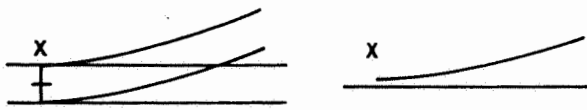

Style U5  
Switch Circuit Controller

### RAILWAY TRACKS

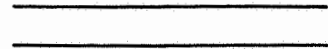

1.0 Meter Gauge  
Track

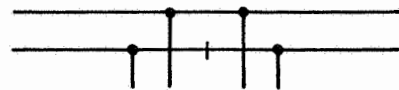

Bootleg Connections  
To Rail

### INSULATED RAIL JOINTS

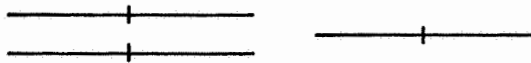

Track Circuits  
In Both Directions

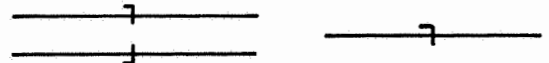

Track Circuit On Left  
None On Right

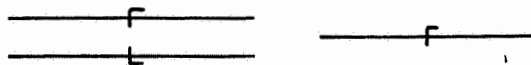

Track Circuit On Right  
None On Left



Insulated Switch Rod



Track Circuit Bond

**SWITCHES  
SINGLE LINE PLAN**

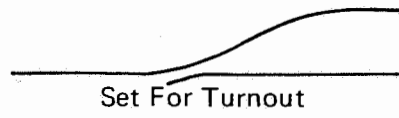
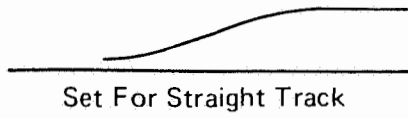

**DOUBLE LINE PLAN**

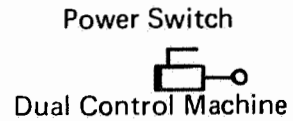
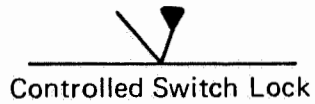
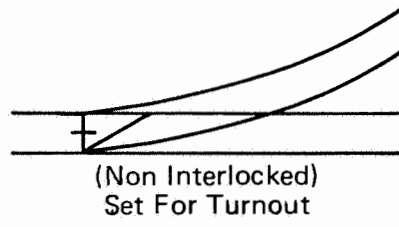
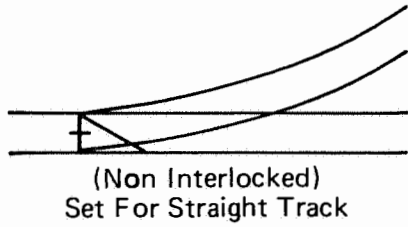
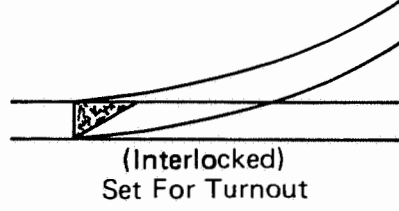
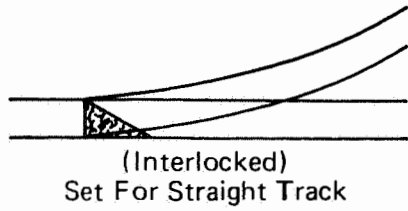

**BUILDINGS**

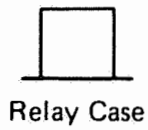
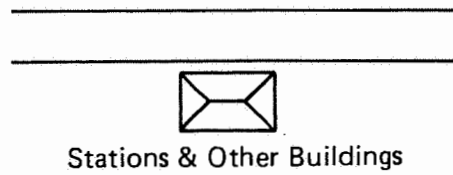
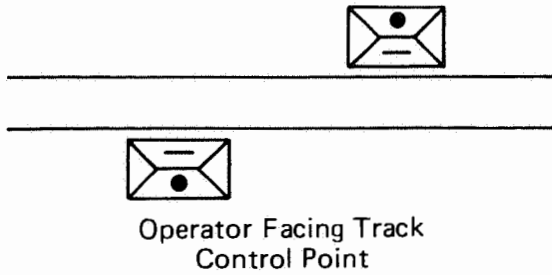

# MISCELLANEOUS APPARATUS

## RESISTORS

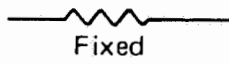

Fixed



Tapped

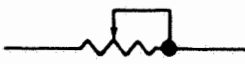

Variable Resistor  
Or Rheostat

## CAPACITORS



Fixed

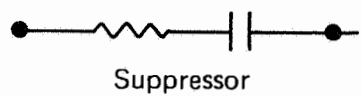

Suppressor

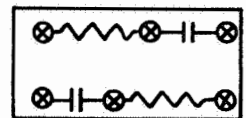

Capacitor Unit



Terminal Strap



Fuse

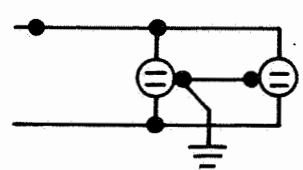

Utility Box  
Dual Outlet

## DIODES (Rectifier)

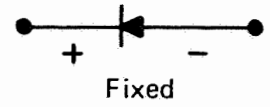

Fixed



Voltage Limiter



Lamp

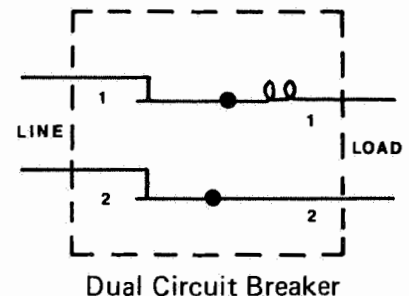

Dual Circuit Breaker

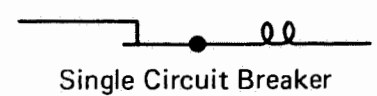

Single Circuit Breaker



## DRAWING SYMBOLS

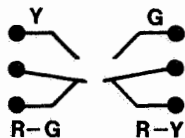
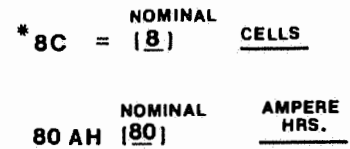
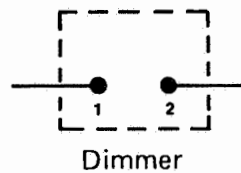
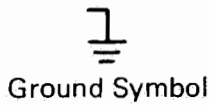
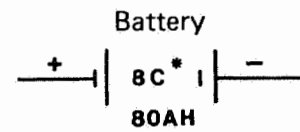
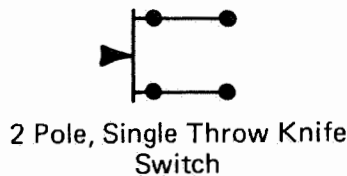
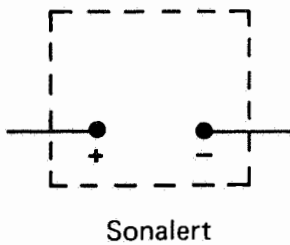
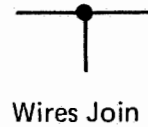
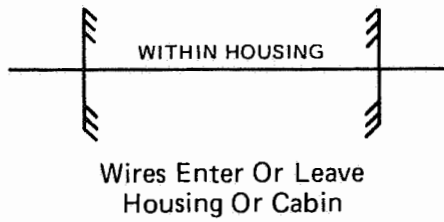
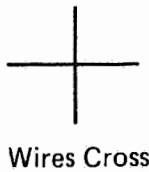
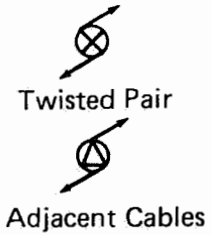

### Contacts On Searchlight Signal Mechanism

Y = Yellow (Contact Closed When Signal Displays Yellow Aspect)

G = Green (Contact Closed When Signal Displays Green Aspect)

R-G = Red-Green (Contact Closed When Signal Displays Red Or Green Aspect)

R-Y = Red-Yellow (Contact Closed When Signal Displays Red Or Yellow Aspect)

# LIGHTNING ARRESTERS

Symbol

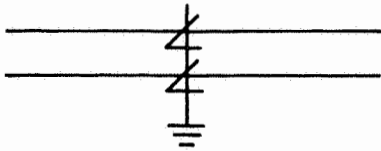

Series

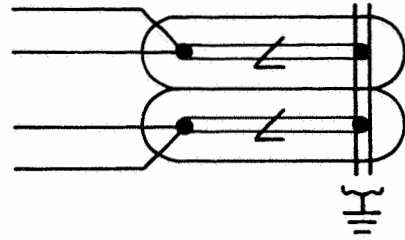

Physical

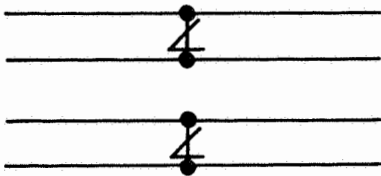

Shunt

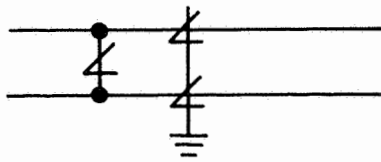
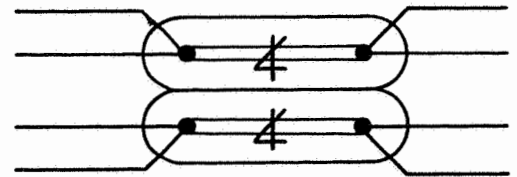

Series-Shunt

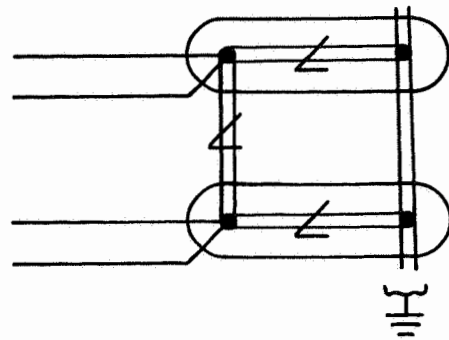

# PLUG CONNECTORS

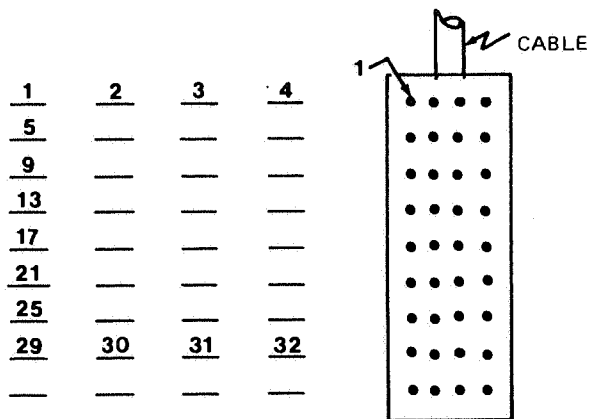
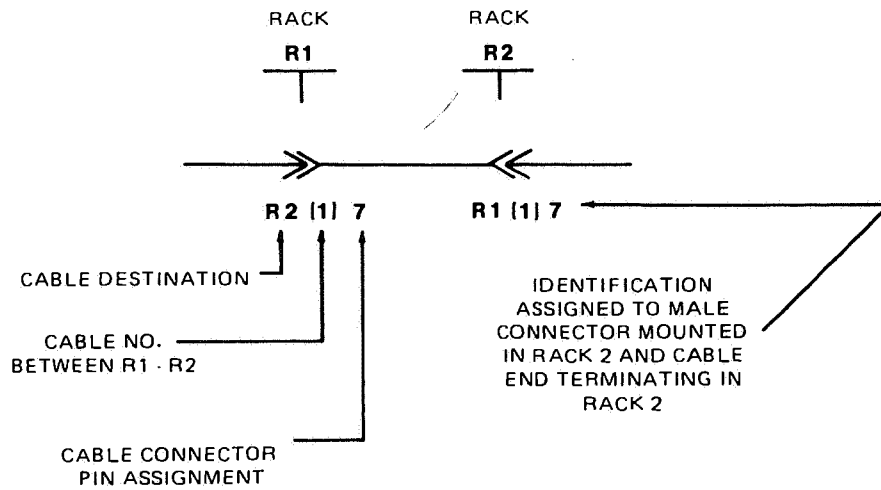

Cable Connector Pin Assignment (Female)

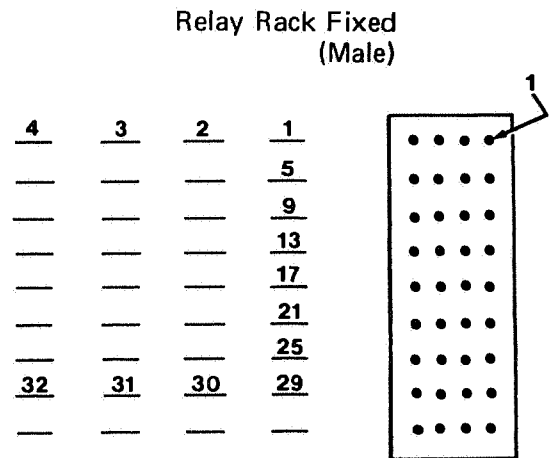

Relay Rack Fixed (Male)

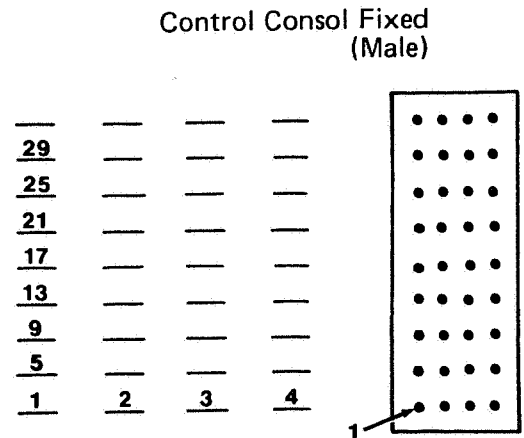

Control Consol Fixed (Male)

# PUSH BUTTON CONTROLLERS

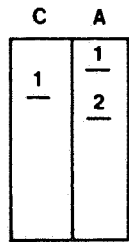

Rear View

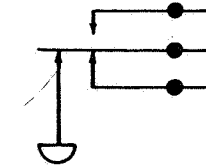

1 NML Open  
1 NML Closed  
UN374214  
Push 2 Pos. Stick

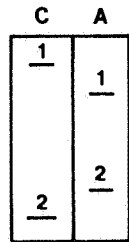
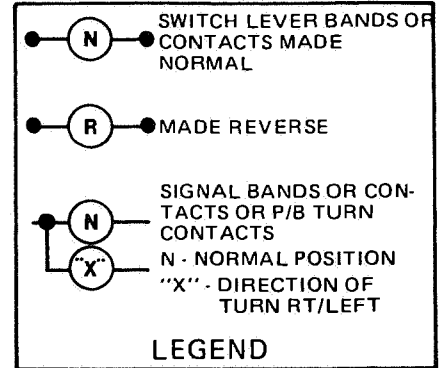

Rear View



Contacts Are Stacked

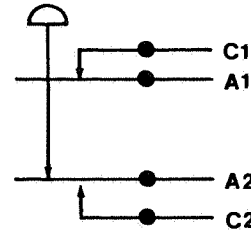

UN380618  
1 NML Open 1 NML Closed  
PUSH PULL ONLY

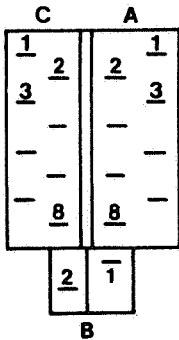

Rear View

N380619

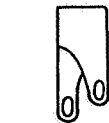

Contacts Are Stacked

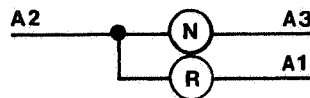

C to R

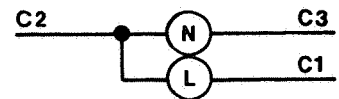

C to L

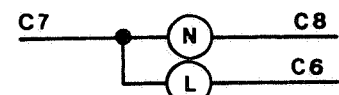
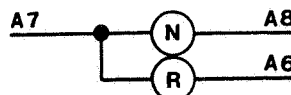
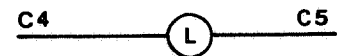
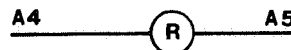

1 Nor. Open - Push  
2 Nor. Closed, 3 Nor. Open C to L  
Or C to R  
UN 380619  
PUSH TURN CL/CR

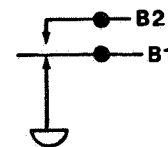

\* Rt. stack is not affected by left turn. . . vice versa

PUSH BUTTONS  
CONT.

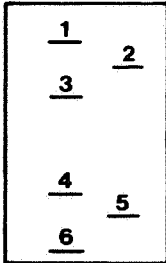

Contact  
Numbering



Contacts  
Are  
Stacked

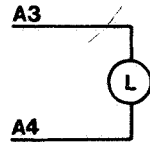

N382242

Left Turn  
Only

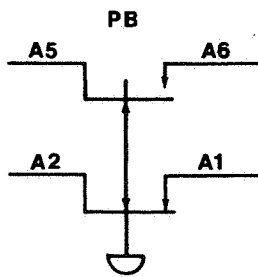

Common  
To  
Both

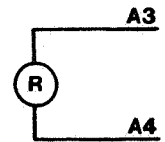

N382229

Right Turn  
Only

Push/Pull; Turn Right Or Left No Push/Pull

REF	DESCRIPTION	CONTACTS DATA	WABCO PC.NO.	BASE PC.NO.	REMARKS
1	PN-150B RELAY	6FB	N322500-701	N334266	BIASED LINE
2					
3	PN-150BTR RELAY	6FB	N322501-701	N334266	1 OHM TRACK
4	PN-150BTR RELAY	6FB	N322501-701	N334266	4 OHM TRACK
5					
6					
7	PN-150BD RELAY	3FB-N 3FB-R	N322504-701	N335727	3-POSITION LINE
8	PN-150BH RELAY	1FB- 1F-1B	N322511-002	N349904	HIGH DROPAWAY TRK
9	PN-150BL RELAY	3FB	N322510-001	N344874	LIGHT OUT
10	PN-150BSR RELAY	6FB	N322503-701	N334266	SLOW DROP, LINE
11					
12	PN-150HD RELAY	6FB	N322505-002	N334266	HEAVY DUTY
13	PN-150N RELAY	6FB	N322502-701	N334266	NEUTRAL, LINE
14	PN-150P RELAY	2FB	N322508-002	N341626	POWER TRANSFER
15					
16					
17					
18	PN-150BM RELAY	2F	N322517-001	N376048	MAGNETIC BLOWOUT
19	PN-150SO RELAY	1FB-1B	N322512-001	N372344	SWITCH OVERLOAD
20	PP-151 RELAY	6NR	N322516-001	N341785	MAG. STICK, LINE
21					
22					
23					
24	PN-250B RELAY	6FB- 6F-3B	N322554-701	N373979	BIASED, LINE
25					
26	PN-258BSR RELAY	6FB	N322551-702	N349769	BIASED, SLOW RELEASE
27					
28	PF-256 RELAY	4NR	N322561-701	N384243	HIGHWAY FLASHER
29					
30					
31	MIDTEX RELAY	4FB	J726153-0053	J725866	NON-VITAL MACH.
32					
33					
34	KP RELAY	4NR	N217122	X253139-001	FINAL STICK

WABCO

DATE: 3-14-78  
: GFM

ARGENTINA RWY  
BOULOGNE TO VILLA ROSA  
MATERIAL TAB

SH 30

REF	DESCRIPTION	CONTACTS DATA	WABCO PC.NO.	BASE PC.NO.	REMARKS
35	W-400 TRANSFORMER	18V 10A	N451428-0106	---	POWER TRANS
36	W-400 TRANSFORMER	18V 20A	N451428-0109	---	HIGH CURRENT
37					
38					
39					
40	CCR-4 RECTIFIER	13.5V	N451372-0101	---	BATT. CHARGE 4-6C
41					
42	CCR-5 RECTIFIER	3.0V	N451372-0104	---	BATT. CHARGE 1-2C
43					
44	CCR-A RECTIFIER	13.5V	N451372-1301	---	BATT. CHARGE 6 c LA
45					
46	CCRP-6 RECTIFIER	30V	N451372-0905	---	BATT CHARGE 10-13C
47					
48					
49					
50	CIRCUIT BRKR 6A	250V	J725694-0034	---	HEINEMAN
51	CIRCUIT BRKR 10A	250V	J725694-0035	---	HEINEMAN
52	CIRCUIT BRKR 15A	250V	J725694-0036	---	HEINEMAN
53					
54	FUSE 10 AMP	250V	J071120	N238637	CARTRIGE TYPE
55					
56					
57	RESISTOR 4.5W	12W	N156683	---	ADJ. FOR LIGHTS
58	RESISTOR 50W		N189956	---	
59	RESISTOR		N156682	---	
60	RESISTOR 100W		N239488	---	
61	RESISTOR 1.2W	12W	N156681	---	ADJ. FOR TRKS.
62	RESISTOR 150W	2W	J721587	---	
63	RESISTOR 200W	2W	J721161	---	FIXED KP SNUB
64	RESISTOR 3000W	5W	J073841	---	
65	RESISTOR		N331321	---	
66					
67					
68					

WABCO

DATE: 3-14-78	ARGENTINA RWY BOULOGNE TO VILLA ROSA SH 31 MATERIAL TAB
: GFM	

REF	DESCRIPTION	CONTACTS DATA	WABCO PC.NO.	BASE PC.NO.	REMARKS
69	DIODE IN4005	600V	J723568	—	KP SNUB
70					
71	SWITCH	—	J072616	—	
72					
73	RHEOSTAT	—	J620826		
74					
75	LGT ARRESTOR	—	N314266	—	SHUNT 50V
76	LGT ARRESTOR	—	N327989	N170501	SERIES 400V
77					
78	SONALERT	2900HZ	J705057	—	TRK #1 ENTR
79	SONALERT	2900HZ	J705057-001	—	EMERG. INDIC.
80	SONALERT	4500HZ	J792472	—	TRK #2 ENTR.
81					
82	DUPLEX RECEPTICAL	—	J072030	BOX J700245 COVER J069834	GROUNDING RECPT
83					
84					
85					
86					
87					
88					
89					
90					
91					
92					
93					
94					
95					
96					
97					
98					
99					
100					

WABCO

DATE: 3-14-78  
: GFM

ARGENTINA RWY  
BOULOGNE TO VILLA ROSA  
MATERIAL TAB

SH 32





