

TECHNICAL MANUAL

ACNF, ADPF, AEPF, ARPF, ARUF, ASPF, ATUF, AWUF Air Handlers

- Refer to Service Manual RS6100004 & RS6200006 for installation, operation & troubleshooting information.
- All safety information must be followed as provided in the Service Manual.
- Refer to the appropriate Parts Catalog for part number information.
- Models listed on page 3.

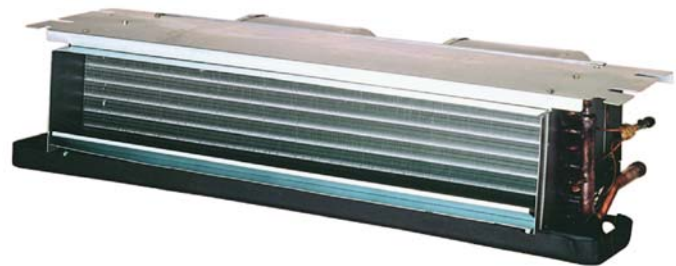
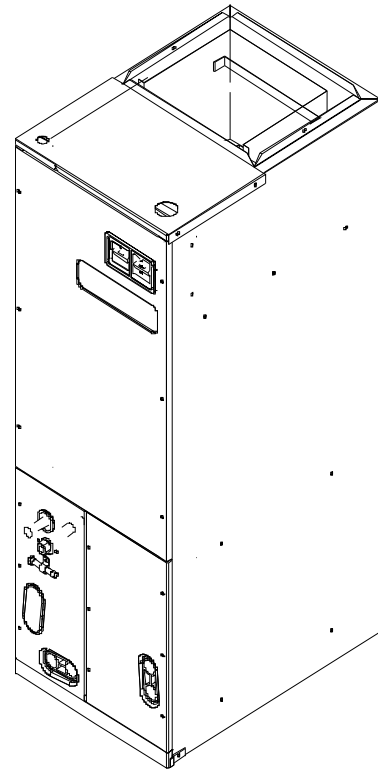

This manual is to be used by qualified, professionally trained HVAC technicians only. Goodman does not assume any responsibility for property damage or personal injury due to improper service procedures or services performed by an unqualified person.

RT6121000r20
September 2013

PRODUCT IDENTIFICATION

The model number is used for positive identification of component parts used in manufacturing. Please use this number when requesting service or parts information.

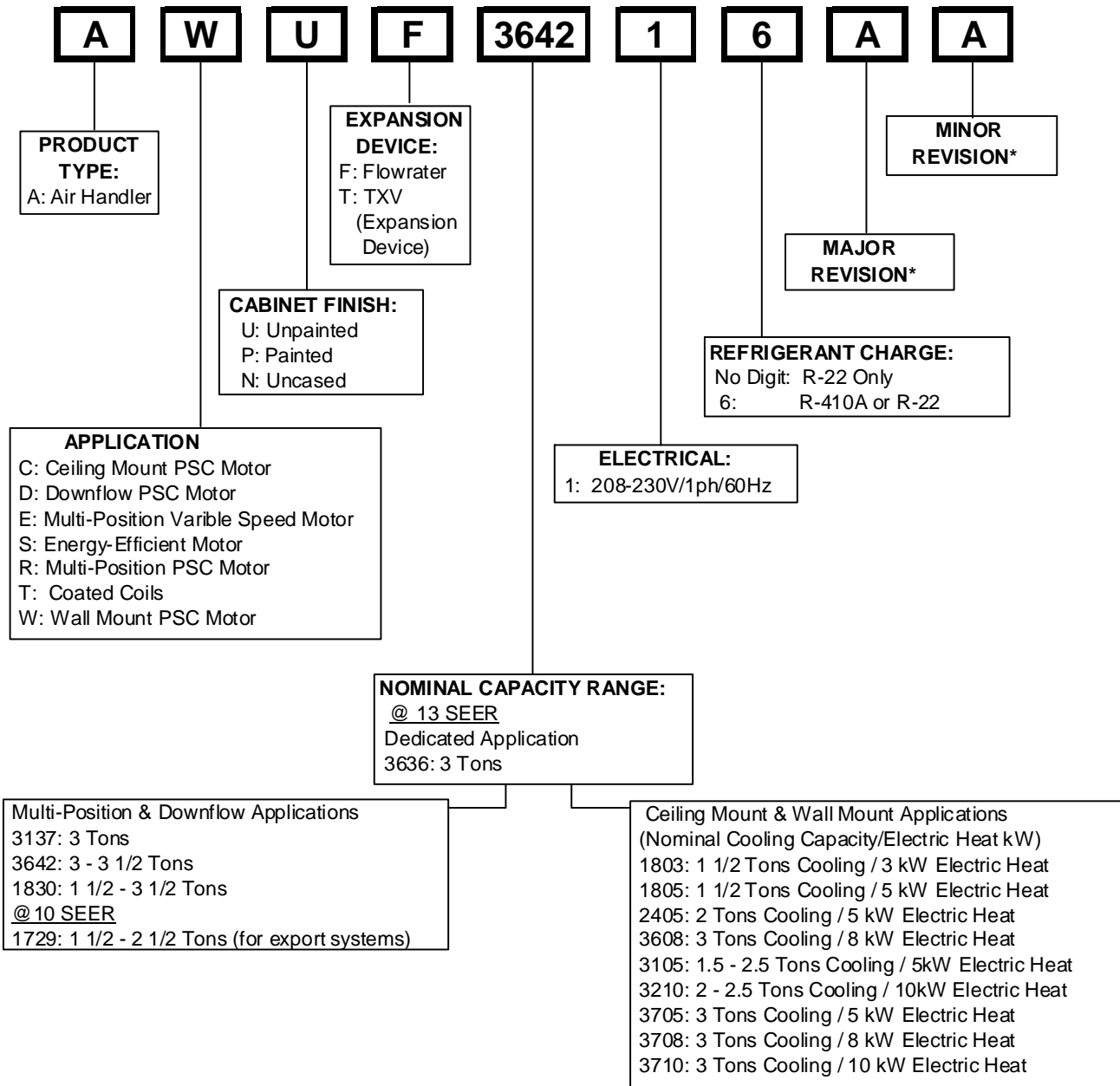

All Airhandlers use DIRECT DRIVE MOTORS. Power supply is AC 208-230v, 60 hz, 1 phase.

WARNING

HIGH VOLTAGE!

Disconnect ALL power before servicing or installing this unit. Multiple power sources may be present. Failure to do so may cause property damage, personal injury or death.

WARNING

Goodman will not be responsible for any injury or property damage arising from improper service or service procedures. If you install or perform service on this unit, you assume responsibility for any personal injury or property damage which may result. Many jurisdictions require a license to install or service heating and air conditioning equipment.

WARNING

Installation and repair of this unit should be performed **ONLY** by individuals meeting the requirements of an "entry level technician", at a minimum, as specified by the Air-Conditioning, Heating, and Refrigeration Institute (AHRI). Attempting to install or repair this unit without such background may result in product damage, personal injury or death.

PRODUCT IDENTIFICATION

The model number is used for positive identification of component parts used in manufacturing. Please use this number when requesting service or parts information.

ACNF18001**	ADPF18241**	ARUF18241**	AWUF18051**
ACNF18051**	ADPF30421**	ARUF30301**	AWUF18081**
ACNF18061**	ADPF48601**	ARUF36421**	AWUF24051**
ACNF18081**	ADPF182416**	ARUF37431**	AWUF24081**
ACNF24001**	ADPF304216**	ARUF48601**	AWUF24101**
ACNF24051**	ADPF486016**	ARUF172916**	AWUF30051**
ACNF24061**		ARUF182416**	AWUF30081**
ACNF24081**	AEPF18301**	ARUF193116**	AWUF30101**
ACNF24101**	AEPF30361**	ARUF303016**	AWUF36051**
ACNF30001**	AEPF31371**	ARUF363616**	AWUF36081**
ACNF30051**	AEPF42601**	ARUF364216**	AWUF36101**
ACNF30061**		ARUF374316**	AWUF37051**
ACNF30081**	ARPF18241**	ARUF486016**	AWUF37081**
ACNF30101**	ARPF30301**	ARUF496116**	AWUF37101**
	ARPF37431**		AWUF180316**
	ARPF48601**	ASPF183016*	AWUF240316**
ACNF180016D*	ARPF182416**	ASPF303616*	AWUF300316**
ACNF180516D*	ARPF193116**	ASPF313716*	
ACNF180616D*	ARPF303016**	ASPF426016*	AWUF240316B*
ACNF180816D*	ARPF363616**		AWUF240516B*
ACNF240016D*	ARPF364216**	ATUF182416**	AWUF240816B*
ACNF240516D*	ARPF374316**	ATUF193116**	AWUF241016B*
ACNF240616D*	ARPF486016**	ATUF303016**	
ACNF240816D*	ARPF496116**	ATUF363616**	AWUF310516A*
ACNF241016D*		ATUF364216**	AWUF310816A*
ACNF300016D*		ATUF374316**	AWUF321016A*
ACNF300516D*		ATUF486016**	
ACNF300616D*			
ACNF300816D*			
ACNF301016D*			



WARNING

The United States Environmental Protection Agency (“EPA”) has issued various regulations regarding the introduction and disposal of refrigerants introduced into this unit. Failure to follow these regulations may harm the environment and can lead to the imposition of substantial fines. These regulations may vary by jurisdiction. Should questions arise, contact your local EPA office.



WARNING

Do not connect or use any device that is not design certified by Goodman for use with this unit. Serious property damage, personal injury, reduced unit performance and/or hazardous conditions may result from the use of such non-approved devices.



WARNING

To prevent the risk of property damage, personal injury, or death, do not store combustible materials or use gasoline or other flammable liquids or vapors in the vicinity of this appliance.

PRODUCT DESIGN



WARNING

When installing or servicing this equipment, safety clothing, including hand and eye protection, is strongly advised. If installing this equipment in an area that has special safety requirements (hard hats etc.), observe these requirements. To protect the unit when brazing close to the painted surfaces, the use of a quenching cloth is strongly advised to prevent scorching or marring of the equipment finish.



WARNING

HIGH VOLTAGE

Disconnect ALL power before servicing or installing this unit. Multiple power sources may be present. Failure to do so may cause property damage, personal injury or death.



WARNING

The unit **MUST** have an uninterrupted, unbroken electrical ground to minimize the possibility of personal injury if an electrical fault should occur. The electrical ground circuit may consist of an appropriately sized electrical wire connecting the ground lug in the unit control box to the building electrical service panel. Other methods of grounding are permitted if performed in accordance with the “National Electric Code” (NEC)/“American National Standards Institute” (ANSI)/“National Fire Protection Association” (NFPA) 70 and local/state codes. In Canada, electrical grounding is to be in accordance with the Canadian Electric Code CSA C22.1. Failure to observe this warning can result in electrical shock that can cause personal injury or death.



WARNING

If this appliance is installed in an enclosed area such as a garage or utility room with any carbon monoxide (CO) producing appliance (i.e. automobile, furnace, water-heaters, etc.), ensure the area is properly ventilated.

AIR HANDLERS

*See Air Handler Specification Sheet for Proper Combinations.

ALL AIR HANDLERS USE DIRECT DRIVE MOTORS. POWER SUPPLY IS 220-240 V, 60 HZ, 1 PHASE

Installation

Before installing this appliance insure that it is properly sized and adequate power is available.

This appliance can be installed in the vertical or right horizontal position without modification. The horizontal left and downflow positions require product modification.

This product is designed for zero inches (0 inches) clearance; however, adequate access for service or replacement must be considered without removing permanent structure. This unit can be installed on a platform when deemed necessary.

In an attic installation a secondary drain pan must be provided by the installer and placed under the entire unit with a separate drain line properly sloped and terminated in an area visible to the owner. This secondary drain pan is required in the event that there is a leak or main drain blockage. Closed cell insulation should be applied to the drain lines in unconditioned spaces where sweating may occur.

Appliances installed in garages, warehouses or other areas where they may be subjected to mechanical damage must be suitably guarded against such damage by installing behind protective barriers, being elevated or located out of the normal path of vehicles. When installed on a base, the base must also be protected by similar means.

Heating and cooling equipment located in garages, which may generate a glow, spark or flame capable of igniting flammable vapors, must be installed with the ignition source at least 18"[46cm] above the floor level.

When more than one appliance is installed in a building it shall be permanently identified as to the area or space serviced by the equipment.

When this product is installed in the downflow installation in an unconditioned space, remove the horizontal drain pan and install the following insulation kit

ARUF, ATUF or ARPF Model	AEPF / ASPF	Insulation Kit
1729 1824	N/A	DPI18-30/20
3030 1931 3636	1830	DPI36-42/20
3642 3743	3036 3137	DPI48-61/-20
4860 4961	4260	

This kit is used to prevent sweating on the vertical drain pan.

PRODUCT DESIGN

To prevent the horizontal drain pan from sweating in high humidity applications, it is recommended that a DPIH insulation accessory kit be used. NOTE: The DPIH insulation kit is not supplied with this product and must be purchased separately.

See Chart below for the correct DPIH kit.

ARUF, ATUF or ARPF Model	AEPF / ASPF	Insulation Kit
1729 1824	N/A	DPIH18-32
3030 1931 3636	1830	DPIH36-42
3642 3743	3036 3137	DPIH48-61
4860 4961	4260	

ACNF AC electric heat air handlers are designed for ceiling mounting and have a direct drive, multi-speed motor. They are available in 1-1/2, 2 and 2 1/2 ton sizes.

AWUF is a vertical stud or wall-mount electric heat air handler and features a direct drive, multi-speed motor. The AWUF has a check flowrater for cooling only and heat pump operation, with sequence controlled heating elements of 5, 8, and 10 kW. The AWUF is available in 1 1/2 to 3 ton sizes.

ADPF is a dedicated downflow, multi-speed air handler and is available in 1 1/2 to 5 ton sizes. Electric heat kits are available as a field-installed option.

***ARPF** air handlers are multi-position, multi-speed with direct drive motors. They are available in 1 1/2 to 5 ton sizes with optional 3 kW to 21kW electric heat kits available for field installation. (See note below.)

ARUF is a multi-position air handler and can be used with R-410A or R-22 (models ending in 1/16) and features a direct drive, multi-speed motor. The ARUF has a check flowrater for cooling-only and heat pump operation. The ARUF is available in 1 1/2 to 5 ton sizes.

***AEPF** is a multi-position, variable-speed air handler and can be used with R-410A or R-22 (models ending in 1/16). The unit's blower design includes a variable-speed DC motor and is compatible with heat pumps and variable-capacity cooling applications. (See note below.)

***ASPF** is a multi-position air handler that can be used with R-410A or R-22 and it features a energy efficient motor. This motor is a constant torque motor with very low power consumption and it is energized by a 24V signal. The energy efficient motor features an integrated control module and is compatible with heat pumps and cooling applications. (See note below.)

***NOTE:** Factory-sealed to achieve a 2% or less leakage rate at 1.0" water gauge external duct static pressure.

Complies with the Factory-sealed Air Handling Credit as listed in the 2001 Florida Building Code, Chapter 13, Section 610.2.A.2.1.

PRODUCT DIMENSIONS

ACNF

Model	A	B	C	D
ACNF18	37 $\frac{1}{4}$ "	34 $\frac{11}{16}$ "	30"	6 $\frac{1}{2}$ "
ACNF24	43 $\frac{1}{4}$ "	40 $\frac{11}{16}$ "	36"	6 $\frac{1}{2}$ "
ACNF30	49 $\frac{1}{4}$ "	46 $\frac{11}{16}$ "	42"	6 $\frac{1}{2}$ "

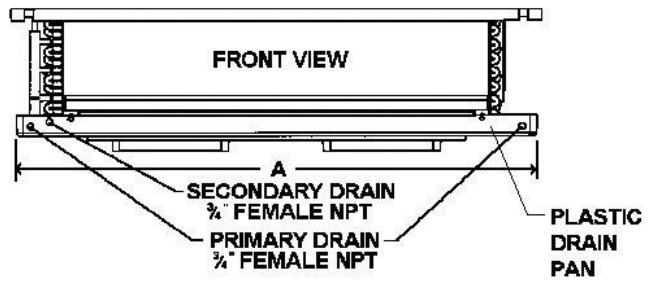
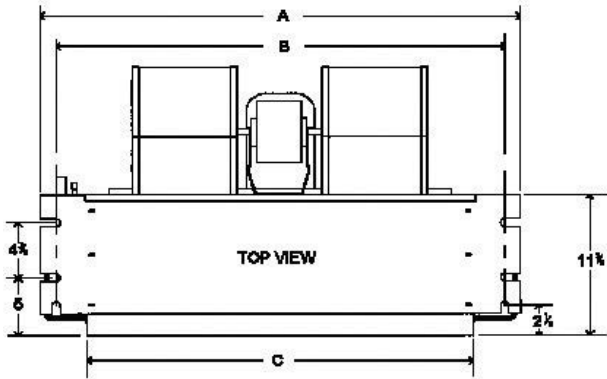
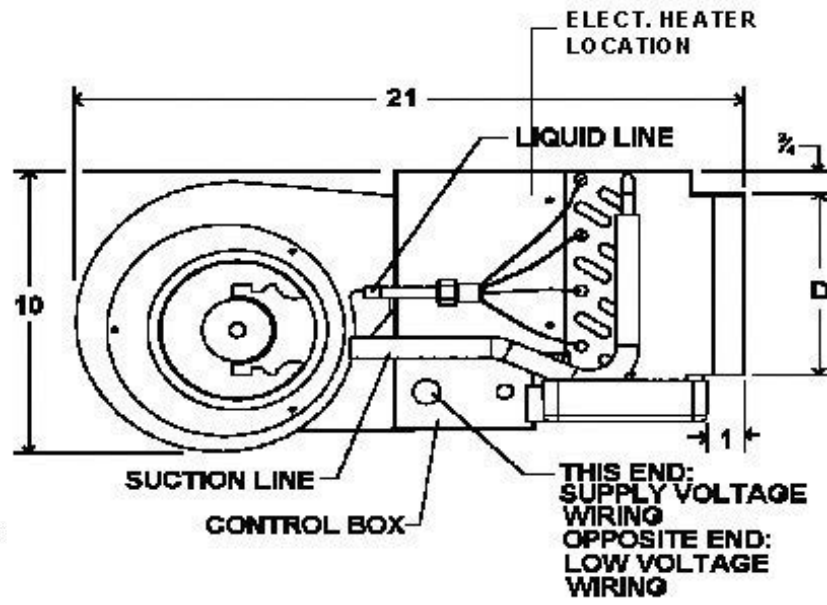

PRODUCT SPECIFICATIONS

ACNF

ACNF*****AA/AB (copper coils)

	ACNF18001	ACNF18051	ACNF18061	ACNF18081	ACNF24001	ACNF24051	ACNF24061	ACNF24081	ANF24101	ACNF30001	ACNF30051	ACNF30061	ACNF30081	ACNF30101
Blower														
Diameter	5.75	5.75	5.75	5.75	6.31	6.31	6.31	6.31	6.31	6.75	6.75	6.75	6.75	6.75
Width	6.75	6.75	6.75	6.75	8.25	8.25	8.25	8.25	8.25	8.25	8.25	8.25	8.25	8.25
Coil Drain Connection FPT	3/4"	3/4"	3/4"	3/4"	3/4"	3/4"	3/4"	3/4"	3/4"	3/4"	3/4"	3/4"	3/4"	3/4"
Lineset Connection Size														
Liquid	3/8"	3/8"	3/8"	3/8"	3/8"	3/8"	3/8"	3/8"	3/8"	3/8"	3/8"	3/8"	3/8"	3/8"
Suction	3/4"	3/4"	3/4"	3/4"	3/4"	3/4"	3/4"	3/4"	3/4"	3/4"	3/4"	3/4"	3/4"	3/4"
Electrical Data														
Min. Circuit Ampacity @ 240V	0.9	27	33.5	40.5	1.68	27.8	34.3	41.3	54.9	1.68	27.8	34.3	41.3	54.9
Min. Circuit Ampacity @ 208V	0.9	2405	30.5	36.8	1.68	25.3	31.36	37.6	49.8	1.68	25.3	31.3	37.6	49
Max. Overcurrent Device 240V	15	30	40	50	15	30	40	50	60	15	30	40	50	8
Max. Overcurrent Device @ 208V	15	30	40	40	15	30	40	40	50	15	30	40	40	60
Minimum VAC	197	197	197	197	197	197	197	197	197	197	197	197	197	50
Maximum VAC	253	253	253	253	253	253	253	253	253	253	253	253	253	253
Blower Motor														
FLA	0.72	0.72	0.72	0.72	1.34	1.34	1.34	1.34	1.34	1.34	1.34	1.34	1.34	1.34
HP	1/8	1/8	1/8	1/8	1/4	1/4	1/4	1/4	1/4	1/4	1/4	1/4	1/4	1/4
Ship Weight (lbs)	59	59	59	59	69	69	69	69	69	79	79	79	79	79

ACNF*****DA (with aluminum coils)

	ACNF180016	ACNF180516	ACNF180616	ACNF180816	ACNF240016	ACNF240516	ACNF240616	ACNF240816	ANF241016	ACNF300016	ACNF300516	ACNF300616	ACNF300816	ACNF301016
Blower														
Diameter	5.75	5.75	5.75	5.75	6.31	6.31	6.31	6.31	6.31	6.75	6.75	6.75	6.75	6.75
Width	6.75	6.75	6.75	6.75	8.25	8.25	8.25	8.25	8.25	8.25	8.25	8.25	8.25	8.25
Coil Drain Connection FPT	3/4"	3/4"	3/4"	3/4"	3/4"	3/4"	3/4"	3/4"	3/4"	3/4"	3/4"	3/4"	3/4"	3/4"
Lineset Connection Size														
Liquid	3/8"	3/8"	3/8"	3/8"	3/8"	3/8"	3/8"	3/8"	3/8"	3/8"	3/8"	3/8"	3/8"	3/8"
Suction	3/4"	3/4"	3/4"	3/4"	3/4"	3/4"	3/4"	3/4"	3/4"	3/4"	3/4"	3/4"	3/4"	3/4"
Electrical Data														
Min. Circuit Ampacity @ 240V	0.9	27	33.5	40.6	1.68	27.8	34.3	41.3	54.9	1.68	27.8	34.3	41.3	54.9
Min. Circuit Ampacity @ 208V	0.9	23.5	29.2	35.3	1.68	24.3	36.1	47.8	49.8	1.68	24.3	29.9	36.1	47.8
Max. Overcurrent Device 240V	15	30	35	45	15	30	45	50	60	15	30	35	45	8
Max. Overcurrent Device @ 208V	15	25	30	40	15	25	40	40	50	15	25	30	40	60
Minimum VAC	197	197	197	197	197	197	197	197	197	197	197	197	197	50
Maximum VAC	253	253	253	253	253	253	253	253	253	253	253	253	253	253
Blower Motor														
FLA	0.72	0.72	0.72	0.72	1.34	1.34	1.34	1.34	1.34	1.34	1.34	1.34	1.34	1.34
HP	1/8	1/8	1/8	1/8	1/4	1/4	1/4	1/4	1/4	1/4	1/4	1/4	1/4	1/4
Ship Weight (lbs)	54	57	57	57	61	64	64	64	64	65	68	68	68	68

BLOWER PERFORMANCE DATA

ACNF

Model	Speed	CFM delivered against External Static Pressure				
		0.1"	0.2"	0.3"	0.4"	0.5"
ACNF18001	High	780	710	625	520	440
	Low	675	585	510	460	400
ACNF18051	High	780	710	625	520	440
	Low	675	585	510	460	400
ACNF18061	High	780	710	625	520	440
	Low	675	585	510	460	400
ACNF18081	High	780	710	625	520	440
	Low	675	585	510	460	400
ACNF24001	High	935	880	810	735	675
	Low	720	680	630	565	490
ACNF24051	High	935	880	810	735	675
	Low	720	680	630	565	490
ACNF24061	High	935	880	810	735	675
	Low	720	680	630	565	490
ACNF24081	High	935	880	810	735	675
	Low	720	680	630	565	490
ACNF24101	High	935	880	810	735	675
	Low	720	680	630	565	490
ACNF30001	High	1,075	1,015	945	865	770
	Low	830	785	720	665	605
ACNF30051	High	1,075	1,015	945	865	770
	Low	830	785	720	665	605
ACNF30061	High	1,075	1,015	945	865	770
	Low	830	785	720	665	605
ACNF30081	High	1,075	1,015	945	865	770
	Low	830	785	720	665	605
ACNF30101	High	1,075	1,015	945	865	770
	Low	830	785	720	665	605

Note: Assumes dry coil with filter in place; 208-volt operation x .96

BLOWER PERFORMANCE DATA

ACNF

ACNF*****DA (with aluminum coils)

Model	Speed	CFM delivered against External Static Pressure				
		0.1"	0.2"	0.3"	0.4"	0.5"
ACNF180016	High	610	525	480	400	320
	Low	545	470	400	340	250
ACNF180516	High	610	525	480	400	320
	Low	545	470	400	340	250
ACNF180616	High	610	525	480	400	320
	Low	545	470	400	340	250
ACNF180616	High	610	525	480	400	320
	Low	545	470	400	340	250
ACNF240016	High	945	860	800	725	670
	Low	850	800	725	680	600
ACNF240516	High	945	860	800	725	670
	Low	850	800	725	680	600
ACNF240616	High	945	860	800	725	670
	Low	850	800	725	680	600
ACNF240816	High	945	860	800	725	670
	Low	850	800	725	680	600
ACNF241016	High	945	860	800	725	670
	Low	850	800	725	680	600
ACNF300016	High	1,060	985	895	805	720
	Low	905	845	780	710	625
ACNF300516	High	1,060	985	895	805	720
	Low	905	845	780	710	625
ACNF300616	High	1,060	985	895	805	720
	Low	905	845	780	710	625
ACNF300816	High	1,060	985	895	805	720
	Low	905	845	780	710	625
ACNF31016	High	1,060	985	895	805	720
	Low	905	845	780	710	625

Heating Capacity/kW Correction Factor

Supply Voltage	240	230	220	210	208
Correction Factor	1.08	1.00	0.92	0.84	0.82

PRODUCT DIMENSIONS

ADPF

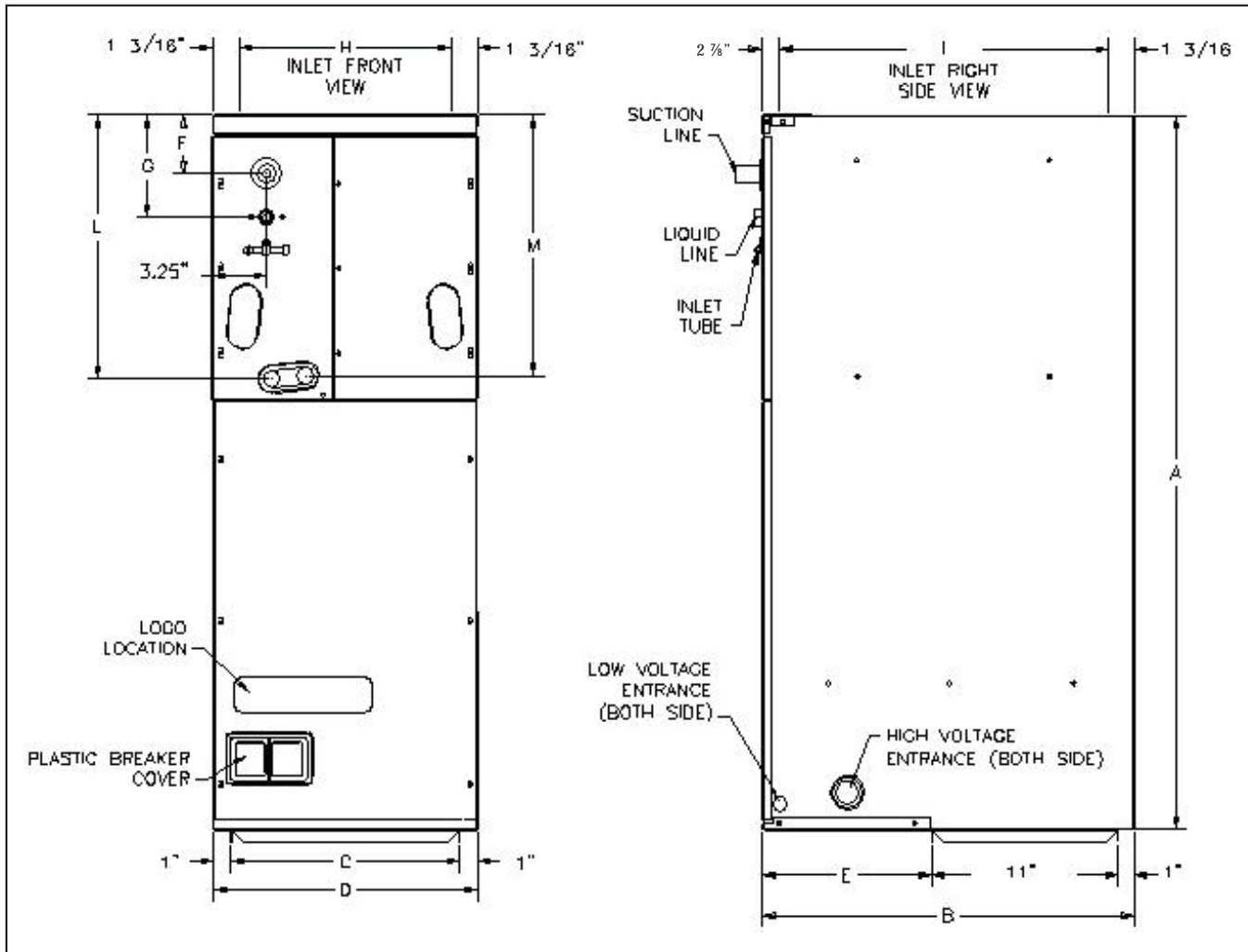

Model	A	B	C	D	E	F	G	H	I	L	M
ADPF18241/16	42 $\frac{1}{8}$ "	22"	13 $\frac{1}{2}$ "	15 $\frac{1}{2}$ "	10"	3 $\frac{1}{2}$ "	6 $\frac{1}{16}$ "	13 $\frac{3}{8}$ "	17 $\frac{15}{16}$ "	15 $\frac{1}{2}$ "	15 $\frac{5}{16}$ "
ADPF30421/16	53 $\frac{3}{4}$ "	24"	20"	22"	12"	9 $\frac{1}{4}$ "	11 $\frac{13}{16}$ "	19 $\frac{5}{8}$ "	19 $\frac{15}{16}$ "	21 $\frac{7}{16}$ "	21 $\frac{1}{4}$ "
ADPF48601/16	53 $\frac{3}{4}$ "	24"	20"	22"	12"	9 $\frac{1}{4}$ "	11 $\frac{13}{16}$ "	19 $\frac{5}{8}$ "	19 $\frac{15}{16}$ "	21 $\frac{7}{16}$ "	21 $\frac{1}{4}$ "

PRODUCT SPECIFICATIONS

ADPF

	ADPF1824 1/16	ADPF3042 1/16	ADPF4860 1/16
Blower			
Diameter	9 1/2"	10 5/8"	10 5/8"
Width	6"	8"	10 5/8"
Coil Drain Connection FPT	3/4"	3/4"	3/4"
Lineset Connection Size			
Liquid	3/8"	3/8"	3/8"
Suction	3/4"	7/8"	7/8"
Electrical Data			
Voltage	208/240	208/240	208/240
Min. Circuit Ampacity*	2.1/2.1	3.7/3.7	5.4/5.4
Max. Overcurrent Device (amps)*	15/15	15/15	15/15
Minimum VAC	197	197	197
Maximum VAC	253	253	253
Blower Motor			
FLA	1.70	2.95	4.30
HP	1/3	1/2	3/4
Ship Weight (lbs)	100	131	160

* @ 208V/240V

BLOWER PERFORMANCE DATA

ADPF

Model	Speed	CFM delivered against External Static Pressure				
		0.1"	0.2"	0.3"	0.4"	0.5"
ADPF18241/16	High	1,155	1,090	1,025	950	895
	Med.	940	890	860	815	755
	Low	695	665	650	610	550
ADPF30421/16	High	1,700	1,660	1,625	1,545	1,505
	Med.	1,500	1,440	1,400	1,350	1,345
	Low	1,370	1,300	1,250	1,230	1,220
ADPF48601/16	High	2,150	2,120	2,070	2,000	1,940
	Med.	1,940	1,930	1,905	1,860	1,790
	Low	1,610	1,600	1,590	1,575	1,550

Note: Assumes dry coil with filter in place; SCFM correction for wet coil = 4% (208V/240V)

PRODUCT DIMENSIONS

AEPF

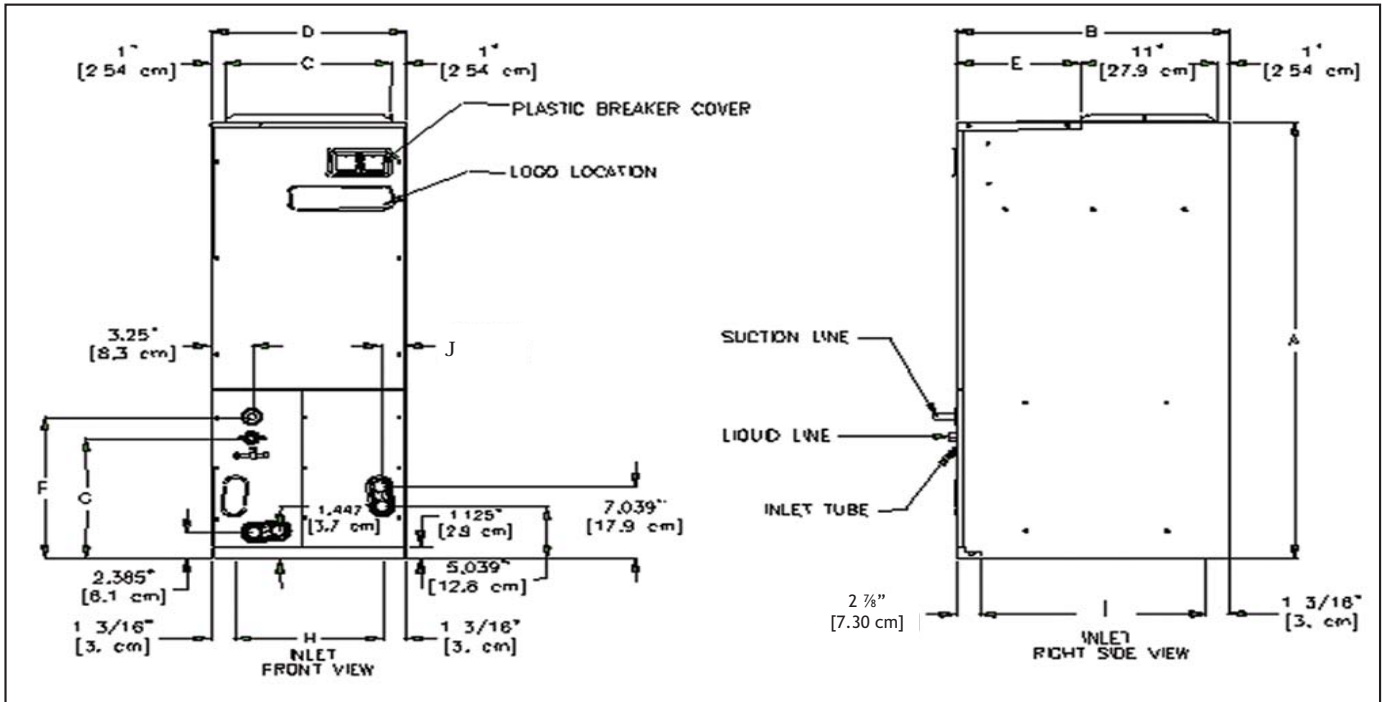

Model	A	B	C	D	E	F	G	H	I	J
AEPF18301/16	46 3/4"	22"	17 1/2"	19 1/2"	10'	14 1/2"	11 15/16"	17 1/8"	17 15/16"	2"
AEPF30361/16	53 1/4"	24"	20"	22"	12"	19 5/8"	11 15/16"	19 5/8"	19 15/16"	1 13/16"
AEPF31371/16	53 1/4"	24"	20"	22"	12"	19 5/8"	11 15/16"	19 5/8"	19 15/16"	1 13/16"
AEPF42601/16	53 1/4"	24"	20"	22"	12"	19 5/8"	11 15/16"	19 5/8"	19 15/16"	1 13/16"

PRODUCT SPECIFICATIONS

AEPF

	AEPF183016*	AEPF303616*	AEPF313716*	AEPF426016*
Blower				
Diameter	9 1/2"	10 5/8"	10 5/8"	10 5/8"
Width	8"	10 5/8"	10 5/8"	10 5/8"
Coil Drain Connection FPT	3/4"	3/4"	3/4"	3/4"
Lineset Connection Size				
Liquid	3/8"	3/8"	3/8"	3/8"
Suction	3/4"	7/8"	7/8"	7/8"
Electrical Data				
Voltage	208/240	208/240	208/240	208/240
Min. Circuit Ampacity*	2.5/2.5	3.1/3.1	3.1/3.1	7.8/7.8
Max. Overcurrent Device (amps)*	15/15	15/15	15/15	15/15
Minimum VAC	197	197	197	197
Maximum VAC	253	253	253	253
Blower Motor				
FLA	2.00	2.50	2.50	6.20
HP	1/2	3/4	3/4	3/4
Ship Weight (lbs)	125	176	176	195

BLOWER PERFORMANCE DATA

AEPF

The AEPF air handler blower motor is pre-programmed for operation at four distinct airflow levels when operating in the Cooling, Heat Pump heating, Backup heating (Electric Heating), and Backup + Heat Pump heating modes. Each mode has four levels to deliver different CFM. Simply flip the dipswitch for a different CFM combination.

Setting the Motor

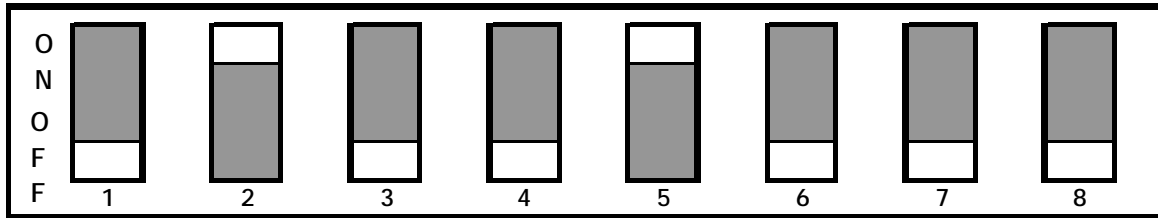

Dipswitch Number	Function	Instructions
1	Electric Heat Mode	Select the taps allow in the tables (dipswitch 1/2 & 7/8) below
2	Electric Heat Mode	
3	N/A	N/A
4	Thermostat Mode	ON = The system operates with single-stage units using a single-stage cooling or heat pump thermostat. (factory default)
		OFF = The system operates with two-stage units with either a conventional two-stage cooling/heat pump thermostat or with an encoded two-stage condensing unit in retrofit applications where not enough existing wires are available for connections to the indo
5	Cooling/Heat Pump Mode	Find the airflow for your application in the tables (Dipswitch 5/6 & 7/8) below.
6	Cooling/Heat Pump Mode	Set up the motor based on the outdoor unit capacity tons.
7	Trim CFM Adjust Mode	Increase or decrease your selected airflow to fit your requirement.
		ON-OFF = Increases selected Cool/Heat Pump airflow by 10%
8	Trim CFM Adjust Mode	OFF-ON = Decreases selected cool/Heat Pump airflow by 15%
		NOTE: Other setting have no effect on the set airflow.

Dipswitch 1/2 & 7/8

AEPF 1830

Heating Element (kw)	Switch Position		Switch Position		Emergency Backup	Heat Pump With Backup
	1	2	7	8		
UP TO 10	OFF	OFF	OFF	OFF	1100	1210
UP TO 10	ON	OFF	OFF	OFF	890	935
5	OFF	ON	OFF	OFF	700	770

Dipswitch 5/6 & 7/8

AEPF 1830

Switch Position		Switch Position		Indoor Airflow	
5	6	7	8	Cooling	Heat Pump
OFF	OFF	OFF	OFF	1100	1100
ON	OFF	OFF	OFF	800	800
OFF	ON	OFF	OFF	600	600

AEPF3036 / 3137 / 4260

Heating Element (kw)	Switch Position		Switch Position		Emergency Backup	Heat Pump With Backup
	1	2	7	8		
UP TO 20	OFF	OFF	OFF	OFF	2050	2150
UP TO 20	ON	OFF	OFF	OFF	1750	1835
UP TO 15	OFF	ON	OFF	OFF	1600	1680
UP TO 10	ON	ON	OFF	OFF	1200	1260
UP TO 10	ON	ON	OFF	ON	1020	1070

AEPF3036 / 3137 / 4260

Switch Position		Switch Position		Indoor Airflow	
5	6	7	8	Cooling	Heat Pump
OFF	OFF	OFF	OFF	1800	1800
ON	OFF	OFF	OFF	1580	1580
OFF	ON	OFF	OFF	1480	1480
ON	ON	OFF	OFF	1200	1200
ON	ON	OFF	ON	1020	1020

NOTE: When applying a humidistat (normally closed), refer to the installation and operating instructions. The humidistat can adjust the cooling airflow to 85%.

PRODUCT DIMENSIONS

ARPF

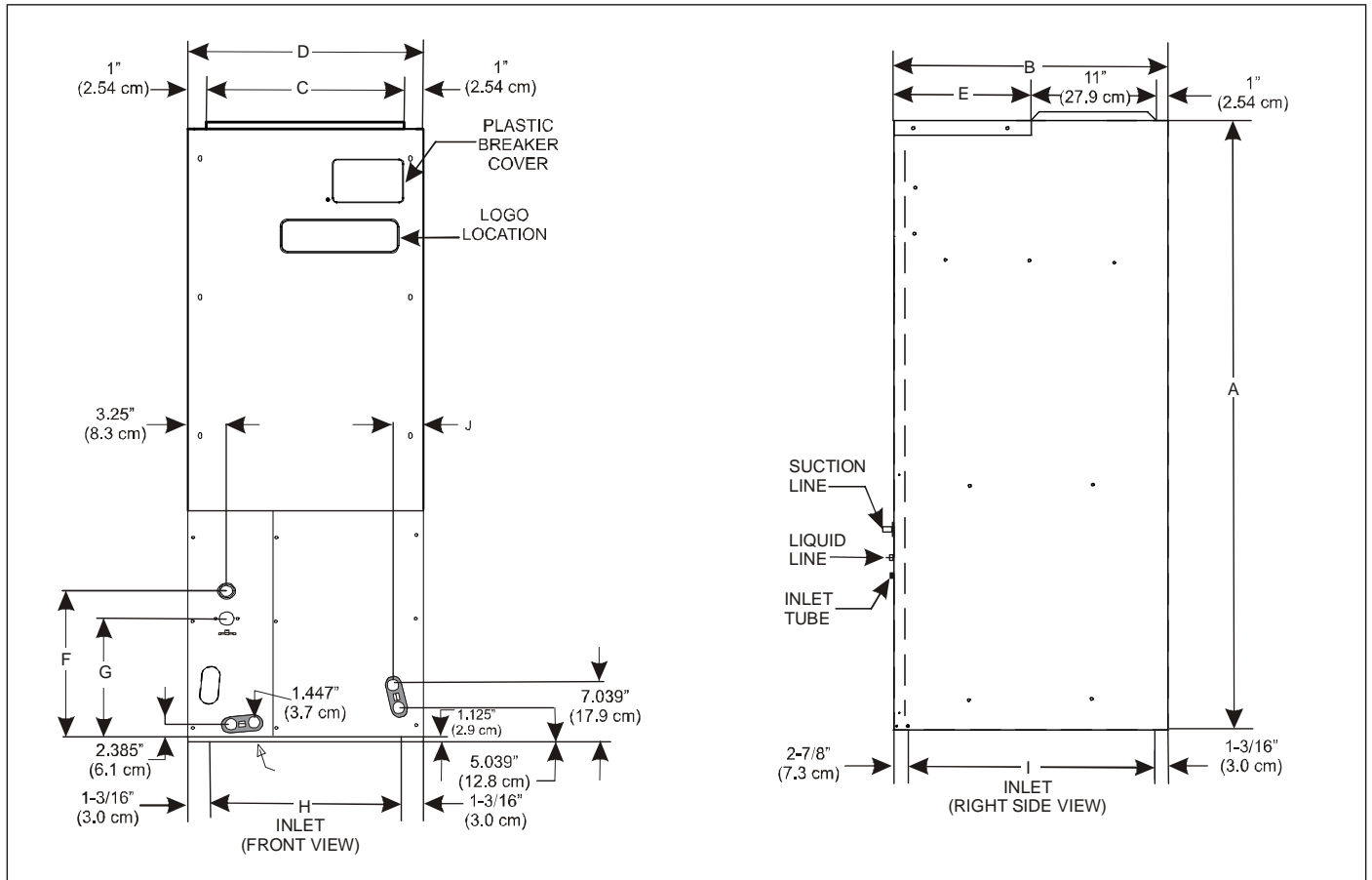

Model	A	B	C	D	E	F	G	H	I	J
ARPF18241*	42 1/8"	22"	13 1/2"	15 1/2"	10"	14 1/2"	11 15/16"	13 1/8"	17 15/16"	2"
ARPF19311*	46 3/4"	22"	17 1/2"	19 1/2"	10"	14 1/2"	11 15/16"	17 1/8"	17 15/16"	2"
ARPF30301*	46 3/4"	22"	17 1/2"	19 1/2"	10"	14 1/2"	11 15/16"	17 1/8"	17 15/16"	2"
ARPF36361*	46 3/4"	22"	17 1/2"	19 1/2"	10"	14 1/2"	11 15/16"	17 1/8"	17 15/16"	2"
ARPF36421*	53 1/4"	24"	20"	22"	12"	14 1/2"	11 15/16"	19 5/8"	19 15/16"	1 13/16"
ARPF37431*	53 1/4"	24"	20"	22"	12"	14 1/2"	11 15/16"	19 5/8"	19 15/16"	1 13/16"
ARPF48601*	53 1/4"	24"	20"	22"	12"	14 1/2"	11 15/16"	19 5/8"	19 15/16"	1 13/16"
ARPF49611*	53 1/4"	24"	20"	22"	12"	14 1/2"	11 15/16"	19 5/8"	19 15/16"	1 13/16"

PRODUCT SPECIFICATIONS

ARPF

	ARPF18241*	ARPF19311*	ARPF30301*	ARPF36361*
Blower				
Diameter	9 1/2"	9 1/2"	9 1/2"	9 1/2"
Width	6"	6"	8"	6"
Coil Drain Connection FPT	3/4"	3/4"	3/4"	3/4"
Lineset Connection Size				
Liquid	3/8"	3/8"	3/8"	3/8"
Suction	3/4"	7/8"	3/4"	3/4"
Electrical Data				
Voltage	208 / 240	208 / 240	208 / 240	208 / 240
Min. Circuit Ampacity	2.1 / 2.1	1.9 / 1.9	3.3 / 3.3	3.3 / 3.3
Max. Overcurrent Device (amps)	15 / 15	15 / 15	15 / 15	15 / 15
Minimum VAC	197	197	197	197
Maximum VAC	253	253	253	253
Blower Motor				
FLA	1.70	1.48	2.64	2.64
HP	1/3	1/4	1/3	1/3
Ship Weight (lbs)	120	155	144	164

	ARPF36421*	ARPF37431*	ARPF48601*	ARPF49611*
Blower				
Diameter	10 5/8"	11 15/16"	10 5/8"	10 5/8"
Width	8"	10 11/16"	10 5/8"	10 5/8"
Coil Drain Connection FPT	3/4"	3/4"	3/4"	3/4"
Lineset Connection Size				
Liquid	3/8"	3/8"	3/8"	3/8"
Suction	7/8"	7/8"	7/8"	7/8"
Electrical Data				
Voltage	208 / 240	208 / 240	208 / 240	208 / 240
Min. Circuit Ampacity	3.7 / 3.7	4.2 / 4.2	5.4 / 5.4	5.4 / 5.4
Max. Overcurrent Device (amps)	15 / 15	15 / 15	15 / 15	15 / 15
Minimum VAC	197	197	197	197
Maximum VAC	253	253	253	253
Blower Motor				
FLA	2.95	3.39	4.30	4.30
HP	1/2	1/2	3/4	3/4
Ship Weight (lbs)	160	195	192	192

BLOWER PERFORMANCE DATA

ARPF

Model	Speed	CFM delivered against External Static Pressure				
		0.1"	0.2"	0.3"	0.4"	0.5"
ARPF18241*	High	1155	1090	1025	950	895
	Med.	940	890	860	815	755
	Low	695	665	650	610	550
ARPF19311*	High	1135	1085	1025	965	915
	Med.	860	825	780	750	680
	Low	600	570	545	500	465
ARPF30301*	High	1385	1315	1240	1155	1065
	Med.	1340	1290	1230	1140	1050
	Low	1075	1030	980	910	840
ARPF36361*	High	1310	1240	1155	1090	1020
	Med.	1270	1210	1140	1075	980
	Low	1045	1005	955	885	805
ARPF36421*	High	1700	1660	1625	1545	1505
	Med.	1500	1440	1400	1350	1345
	Low	1330	1300	1250	1230	1220
ARPF37431*	High	2065	2000	1925	1860	1780
	Med.	1685	1635	1550	1470	1410
	Low	1490	1425	1345	1280	1205
ARPF48601*	High	2150	2120	2070	2000	1940
	Med.	1940	1930	1905	1860	1790
	Low	1610	1600	1590	1575	1550
ARPF49611*	High	2150	2105	2040	1970	1880
	Med.	1960	1935	1895	1825	1750
	Low	1670	1625	1585	1525	1455

Note: Assumes dry coil with filter in place; SCFM correction for wet coil = 4% (208V/240V)

PRODUCT DIMENSIONS

ARUF

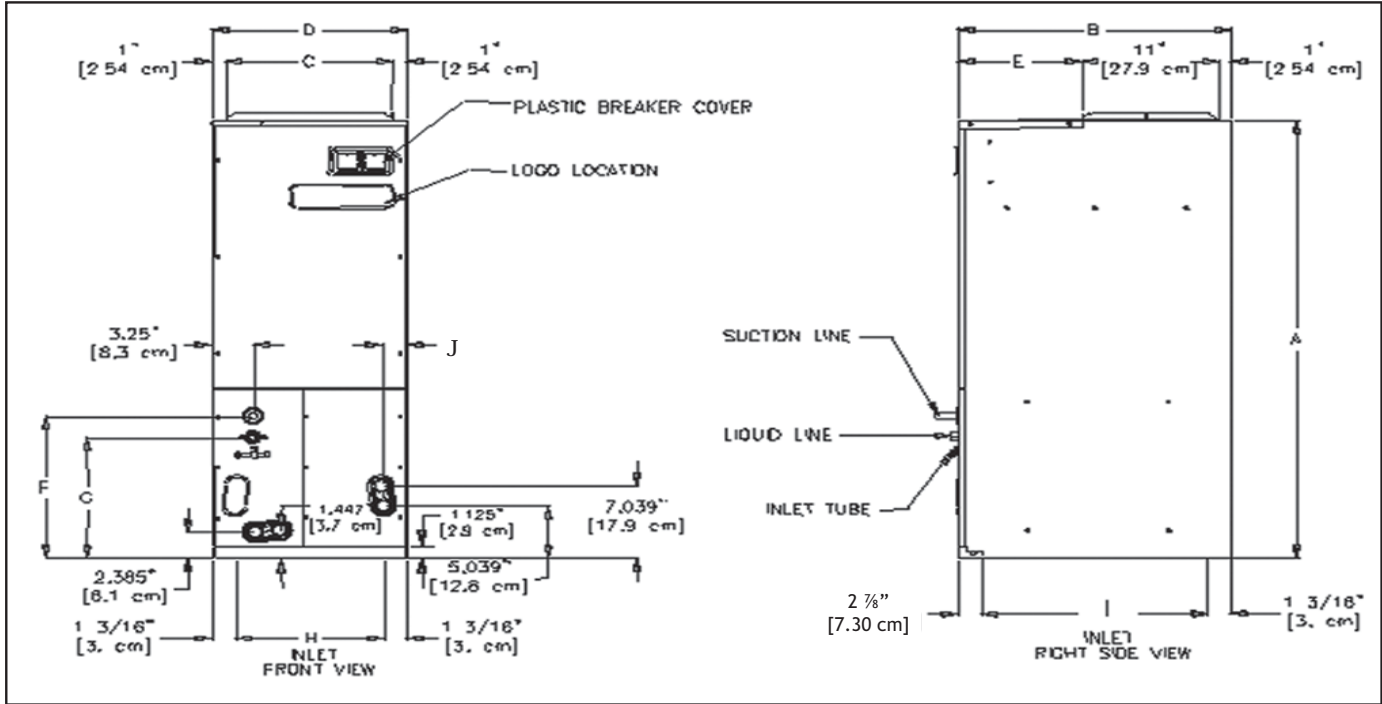

Model	A	B	C	D	E	F	G	H	I	J
ARUF172916	42 1/8"	22"	13 1/2"	15 1/2"	10"	14 1/2"	11 15/16"	13 1/8"	17 15/16"	2"
ARUF182416	42 1/8"	22"	13 1/2"	15 1/2"	10"	14 1/2"	11 15/16"	13 1/8"	17 15/16"	2"
ARUF193116	46 3/4"	22"	17 1/2"	19 1/2"	10"	14 1/2"	11 15/16"	17 1/8"	17 15/16"	2"
ARUF303016	46 3/4"	22"	17 1/2"	19 1/2"	10"	14 1/2"	11 15/16"	17 1/8"	17 15/16"	2"
ARUF363616	46 3/4"	22"	17 1/2"	19 1/2"	10"	14 1/2"	11 15/16"	17 1/8"	17 15/16"	2"
ARUF364216	53 1/4"	24"	20"	22"	12"	14 1/2"	11 15/16"	19 5/8"	19 15/16"	1 13/16"
ARUF374316	53 1/4"	24"	20"	22"	12"	14 1/2"	11 15/16"	19 5/8"	19 15/16"	1 13/16"
ARUF486016	53 1/4"	24"	20"	22"	12"	14 1/2"	11 15/16"	19 5/8"	19 15/16"	1 13/16"
ARUF496116	53 1/4"	24"	20"	22"	12"	14 1/2"	11 15/16"	19 5/8"	19 15/16"	1 13/16"

PRODUCT SPECIFICATIONS

ARUF

	ARUF172916	ARUF182416	ARUF193116	ARUF303016
Blower				
Diameter	9 1/2"	9 1/2"	9 1/2"	9 1/2"
Width	6"	6"	6"	8"
Coil Drain Connection FPT	3/4"	3/4"	3/4"	3/4"
Lineset Connection Size				
Liquid	3/8"	3/8"	3/8"	3/8"
Suction	3/4"	7/8"	3/4"	3/4"
Electrical Data				
Voltage	208 / 240	208 / 240	208 / 240	208 / 240
Min. Circuit Ampacity	2.1 / 2.1	2.1 / 2.1	1.9 / 1.9	3.3 / 3.3
Max. Overcurrent Device (amps)	15 / 15	15 / 15	15 / 15	15 / 15
Minimum VAC	197	197	197	197
Maximum VAC	253	253	253	253
Blower Motor				
FLA	1.70	1.70	1.48	2.64
HP	1/3	1/3	1/4	1/3
Ship Weight (lbs)	110	120	155	144

	ARUF363616	ARUF364216	ARUF374316	ARUF486016	ARUF496116
Blower					
Diameter	9 1/2"	10 5/8"	11 15/16"	10 5/8"	10 5/8"
Width	6"	8"	10 11/16"	10 5/8"	10 5/8"
Coil Drain Connection FPT	3/4"	3/4"	3/4"	3/4"	3/4"
Lineset Connection Size					
Liquid	3/8"	3/8"	3/8"	3/8"	3/8"
Suction	3/4"	7/8"	7/8"	7/8"	7/8"
Electrical Data					
Voltage	208 / 240	208 / 240	208 / 240	208 / 240	208 / 240
Min. Circuit Ampacity	3.3 / 3.3	3.7 / 3.7	4.2 / 4.2	5.4 / 5.4	5.4 / 5.4
Max. Overcurrent Device (amps)	15 / 15	15 / 15	15 / 15	15 / 15	15 / 15
Minimum VAC	197	197	197	197	197
Maximum VAC	253	253	253	253	253
Blower Motor					
FLA	2.64	2.95	3.39	4.30	4.30
HP	1/3	1/2	1/2	3/4	3/4
Ship Weight (lbs)	164	160	195	192	192

BLOWER PERFORMANCE DATA

ARUF

Model	Speed	CFM deliverd against External Static Pressure				
		0.1"	0.2"	0.3"	0.4"	0.5"
ARUF172916	High	1155	1090	1025	950	895
	Med.	940	890	860	815	755
	Low	695	665	650	610	550
ARUF182416	High	1155	1090	1025	950	895
	Med.	940	890	860	815	755
	Low	695	665	650	610	550
ARUF193116	High	1135	1085	1025	965	915
	Med.	860	825	780	750	680
	Low	600	570	545	500	465
ARUF303016	High	1385	1315	1240	1155	1065
	Med.	1340	1290	1230	1140	1050
	Low	1075	1030	980	910	840
ARUF363616	High	1310	1240	1155	1090	1020
	Med.	1270	1210	1140	1075	980
	Low	1045	1005	955	885	805
ARUF364216	High	1700	1660	1625	1545	1505
	Med.	1500	1440	1400	1350	1345
	Low	1330	1300	1250	1230	1220
ARUF374316	High	2065	2000	1925	1860	1780
	Med.	1685	1635	1550	1470	1410
	Low	1490	1425	1345	1280	1205
ARUF486016	High	2150	2120	2070	2000	1940
	Med.	1940	1930	1905	1860	1790
	Low	1610	1600	1590	1575	1550
ARUF496116	High	2150	2105	2040	1970	1880
	Med.	1960	1935	1895	1825	1750
	Low	1670	1625	1585	1525	1455

Note: Assumes dry coil with filter in place; SCFM correction for wet coil = 4% (208V/240V)

PRODUCT DIMENSIONS

ASPF

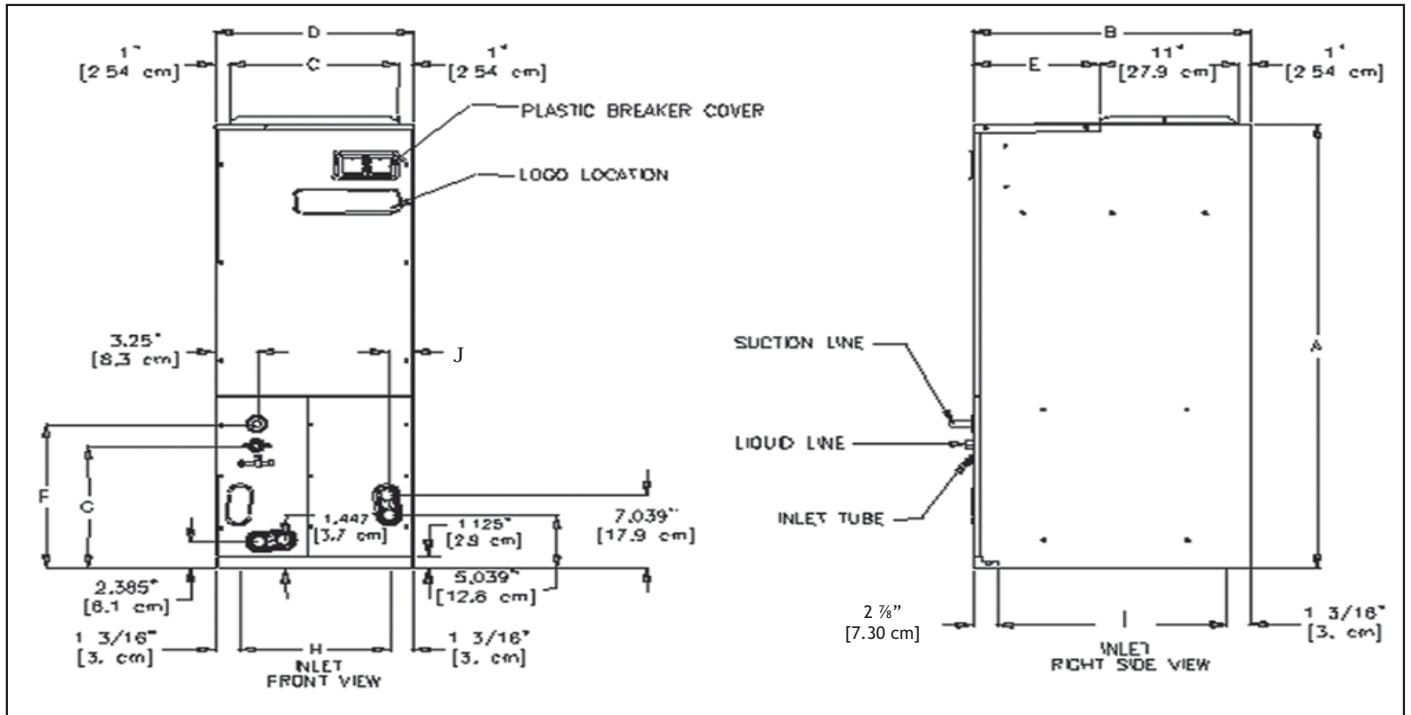

Model	A	B	C	D	E	F	G	H	I	J
ASPF183016*	46 3/4"	22"	17 1/2"	19 1/2"	10'	14 1/2"	11 15/16"	17 1/8"	17 15/16"	2"
ASPF303616*	53 1/4"	24"	20"	22"	12"	19 5/8"	11 15/16"	19 5/8"	19 15/16"	1 13/16"
ASPF313716*	53 1/4"	24"	20"	22"	12"	19 5/8"	11 15/16"	19 5/8"	19 15/16"	1 13/16"
ASPF426016*	53 1/4"	24"	20"	22"	12"	19 5/8"	11 15/16"	19 5/8"	19 15/16"	1 13/16"

PRODUCT SPECIFICATIONS

ASPF

	ASPF183016*	ASPF303616*	ASPF313716*	ASPF426016*
Blower				
Diameter	9 1/2"	10 5/8"	10 5/8"	10 15/16"
Width	8"	10 5/8"	10 5/8"	10 11/16"
Coil Drain Connection FPT	3/4"	3/4"	3/4"	3/4"
Lineset Connection Size				
Liquid	3/8"	3/8"	3/8"	3/8"
Suction	3/4"	7/8"	7/8"	7/8"
Electrical Data				
Voltage	208 / 230	208 / 230	208 / 230	208 / 230
Min. Circuit Ampacity	3.6 / 3.6	3.8 / 3.8	3.9 / 3.9	6.4 / 6.4
Max. Overcurrent Device (amps)	15 / 15	15 / 15	15 / 15	15 / 15
Minimum VAC	197	197	197	197
Maximum VAC	253	253	253	253
Blower Motor				
FLA	2.9	3.0	3.1	5.1
HP	1/2	3/4	3/4	3/4
Ship Weight (lbs)	125	176	176	195

BLOWER PERFORMANCE DATA

ASPF

Model	Motor Speed Tap	CFM delivered against External Static Pressure				
		0.1"	0.2"	0.3"	0.4"	0.5"
ASPF183016	1	700	670	650	595	510
	2	820	785	765	745	705
	3	920	900	850	840	815
	4	1075	1055	1015	975	960
	5	1130	1115	1085	1040	1000
ASPF303616	1	1060	865	600	515	420
	2	1105	910	795	745	690
	3	1165	1070	1020	960	915
	4	1285	1240	1195	1140	1100
	5	1435	1395	1350	1315	1265
ASPF313716	1	1060	865	600	515	420
	2	1105	910	795	745	690
	3	1165	1070	1020	960	915
	4	1285	1240	1195	1140	1100
	5	1435	1395	1350	1315	1265
ASPF426016	1	1445	1275	1175	940	855
	2	1545	1405	1325	1260	1145
	3	1660	1610	1555	1490	1415
	4	1905	1870	1810	1750	1695
	5	2115	2070	2000	1965	1915

Notes: Assumes dry coil with filter in place; SCFM correction for wet coil = 4% (208/240V)
 All ASPF models are shipped from the factory with the speed tap set on T4.

Notes: Assumes dry coil with filter in place; SCFM correction for wet coil = 4% (208/240V)
 All ASPF models are shipped from the factory with the speed tap set on T4.

PRODUCT DIMENSIONS

ATUF

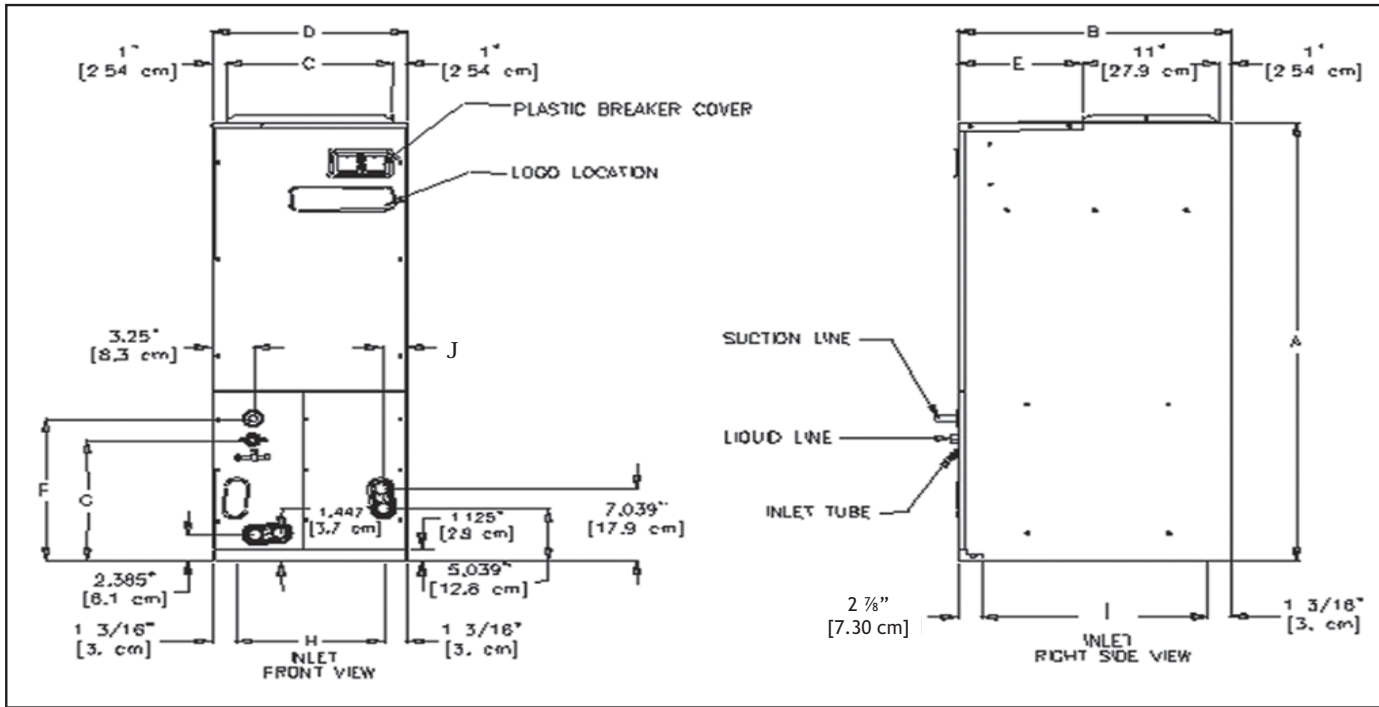

Model	A	B	C	D	E	F	G	H	I	J
ATUF182416	42 1/8"	22"	13 1/2"	15 1/2"	10"	14 1/2"	11 15/16"	13 1/8"	17 15/16"	2"
ATUF193116	46 3/4"	22"	17 1/2"	19 1/2"	10"	14 1/2"	11 15/16"	17 1/8"	17 15/16"	2"
ATUF303016	46 3/4"	22"	17 1/2"	19 1/2"	10"	14 1/2"	11 15/16"	17 1/8"	17 15/16"	2"
ATUF363616	46 3/4"	22"	17 1/2"	19 1/2"	10"	14 1/2"	11 15/16"	17 1/8"	17 15/16"	2"
ATUF364216	53 1/4"	24"	20"	22"	12"	14 1/2"	11 15/16"	19 5/8"	19 15/16"	1 13/16"
ATUF374316	53 1/4"	24"	20"	22"	12"	14 1/2"	11 15/16"	19 5/8"	19 15/16"	1 13/16"
ATUF486016	53 1/4"	24"	20"	22"	12"	14 1/2"	11 15/16"	19 5/8"	19 15/16"	1 13/16"

PRODUCT SPECIFICATIONS

ATUF

	ATUF182416	ATUF193116	ATUF303016	ATUF363616
Blower				
Diameter	9 1/2"	9 1/2"	9 1/2"	9 1/2"
Width	6"	6"	8"	6"
Coil Drain Connection FPT	3/4"	3/4"	3/4"	3/4"
Lineset Connection Size				
Liquid	3/8"	3/8"	3/8"	3/8"
Suction	7/8"	3/4"	3/4"	3/4"
Electrical Data				
Voltage	208 / 240	208 / 240	208 / 240	208 / 240
Min. Circuit Ampacity	2.1 / 2.1	1.9 / 1.9	3.3 / 3.3	3.3 / 3.3
Max. Overcurrent Device (amps)	15 / 15	15 / 15	15 / 15	15 / 15
Minimum VAC	197	197	197	197
Maximum VAC	253	253	253	253
Blower Motor				
FLA	1.70	1.48	2.64	2.64
HP	1/3	1/4	1/3	1/3
Ship Weight (lbs)	120	155	144	164

	ATUF364216	ATUF374316	ATUF486016
Blower			
Diameter	10 5/8"	11 15/16"	10 5/8"
Width	8"	10 11/16"	10 5/8"
Coil Drain Connection FPT	3/4"	3/4"	3/4"
Lineset Connection Size			
Liquid	3/8"	3/8"	3/8"
Suction	7/8"	7/8"	7/8"
Electrical Data			
Voltage	208 / 240	208 / 240	208 / 240
Min. Circuit Ampacity	3.7 / 3.7	4.2 / 4.2	5.4 / 5.4
Max. Overcurrent Device (amps)	15 / 15	15 / 15	15 / 15
Minimum VAC	197	197	197
Maximum VAC	253	253	253
Blower Motor			
FLA	2.95	3.39	4.30
HP	1/2	1/2	3/4
Ship Weight (lbs)	173	195	192

BLOWER PERFORMANCE DATA

ATUF

Model	Speed	CFM delivered against External Static Pressure				
		0.1"	0.2"	0.3"	0.4"	0.5"
ATUF182416	High	1,155	1,090	1,025	950	895
	Med.	875	830	790	750	715
	Low	640	610	570	535	490
ATUF193116	High	1,135	1,085	1,025	965	915
	Med.	860	825	780	750	680
	Low	600	570	545	500	465
ATUF303016	High	1,455	1,385	1,330	1,205	1,090
	Med.	1,340	1,290	1,230	1,140	1,050
	Low	1,075	1,030	980	910	840
ATUF363616	High	1,345	1,290	1,230	1,150	1,070
	Med.	1,270	1,210	1,140	1,075	980
	Low	1,045	1,005	955	885	805
ATUF364216	High	1,700	1,680	1,645	1,610	1,535
	Med.	1,500	1,480	1,440	1,380	1,325
	Low	1,135	1,320	1,275	1,230	1,195
ATUF374316	High	2,065	2,000	1,925	1,860	1,780
	Med.	1,685	1,635	1,550	1,470	1,410
	Low	1,490	1,425	1,345	1,280	1,205
ATUF486016	High	2,135	2,080	1,985	1,900	1,805
	Med.	1,975	1,935	1,875	1,775	1,675
	Low	1,715	1,670	1,650	1,590	1,530

Note: Assumes dry coil with filter in place; SCFM correction for wet coil = 4% (208V/240V)

PRODUCT DIMENSIONS

AWUF

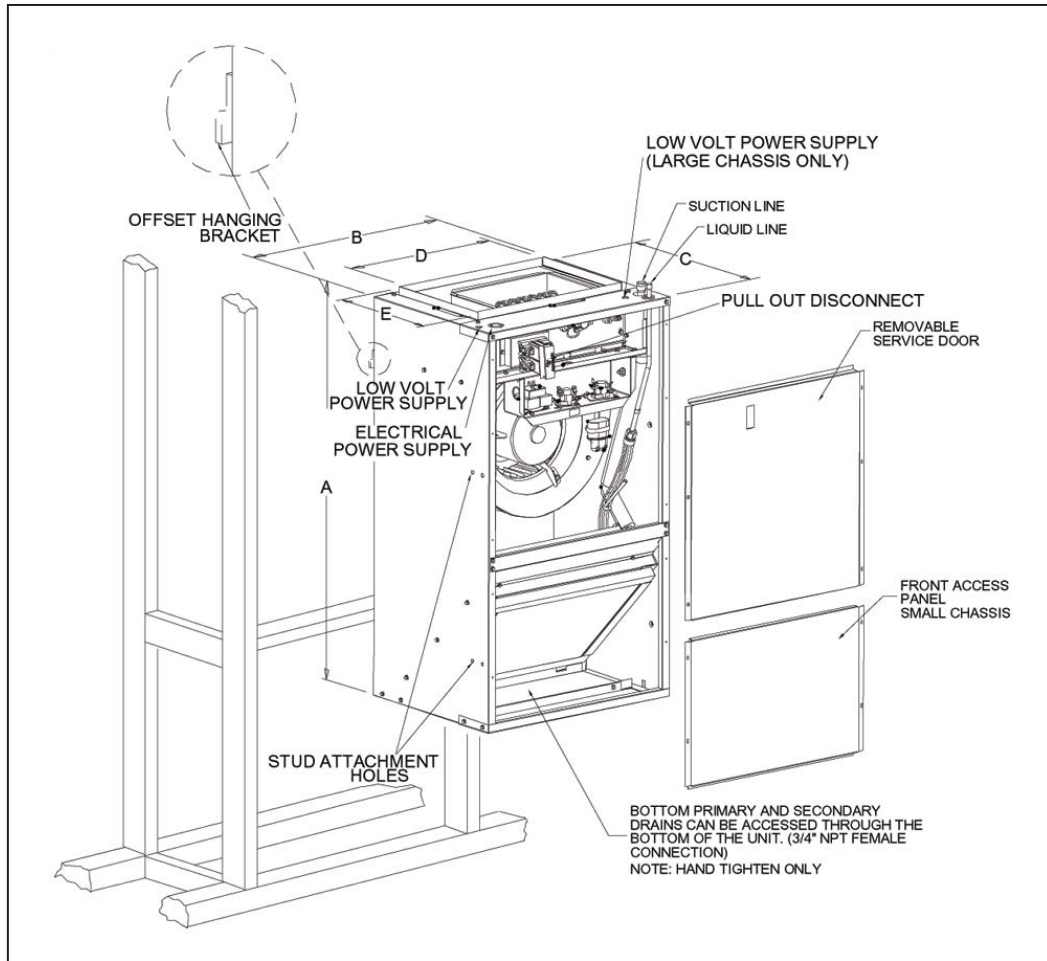

Small Chassis AWUF 18 & 24	
A	36"
B	20 3/8"
C	16 1/8"
D	16"
E	11"
FILTER	14" X 18" X 1"

Large Chassis AWUF 30 BA & 36 BA	
A	36"
B	24"
C	21"
D	19 7/8"
E	15 7/8"
FILTER	16" X 20" X 1"

Large Chassis AWUF 30 BB & 36 BB	
A	36"
B	24"
C	21"
D	19 7/8"
E	15 7/8"
FILTER	18" X 20" X 1"

Large Chassis AWUF 31,32 & 37	
A	36"
B	24"
C	21"
D	19 7/8"
E	15 7/8"
FILTER	18" X 20" X 1"

PRODUCT SPECIFICATIONS

AWUF[18-37]A*

	AWUF18031**	AWUF18051	AWUF18081	AWUF24031**	AWUF24051	AWUF24081	AWUF24101	AWUF30031**	AWUF30051	AWUF30081	AWUF30101
Heating Capacity											
Actual kW @ 240 volts	3.0	4.8	7.3	3.0	4.8	7.3	9.8	3.0	4.8	7.3	9.8
BTU/h @ 240 volts	10,240	16,390	24,925	10,240	16,390	24,925	33,460	10,240	16,390	24,925	33,460
Blower											
Diameter	9"	9"	9"	10"	10"	10"	10"	9"	9"	9"	9"
Width	6"	6"	6"	6"	6"	6"	6"	8"	8"	8"	8"
Coil Drain Connection FPT	3/4"	3/4"	3/4"	3/4"	3/4"	3/4"	3/4"	3/4"	3/4"	3/4"	3/4"
Lineset Connection Size											
Liquid	3/8"	3/8"	3/8"	3/8"	3/8"	3/8"	3/8"	3/8"	3/8"	3/8"	3/8"
Suction	5/8"	5/8"	5/8"	5/8"	5/8"	5/8"	5/8"	3/4"	3/4"	3/4"	3/4"
Electrical Data											
Min. Circuit Ampacity*	15.1/17.3	26.7/23.3	39.7/34.2	15.1/17.3	26.7/23.3	39.7/34.2	52.7/45.6	15.5/17.6	27.0/23.6	40.0/34.9	53.0/46.2
Max. Overcurrent Device (amps)*	20/20	30/30	40/40	20/20	30/30	40/40	60/50	20/20	30/25	40/35	60/50
Minimum VAC	197	197	197	197	197	197	197	197	197	197	197
Maximum VAC	253	253	253	253	253	253	253	253	253	253	253
Blower Motor											
FLA	1.30	1.35	1.35	1.30	1.35	1.35	1.35	1.58	1.58	1.58	1.58
HP	1/5	1/5	1/5	1/5	1/5	1/5	1/5	1/3	1/3	1/3	1/3
Ship Weight (lbs)	84	84	84	84	84	84	84	93	93	93	93

* @ 240V/208V

	AWUF310516	AWUF310816	AWUF321016	AWUF36051	AWUF36081	AWUF36101	AWUF37051	AWUF37081	AWUF37101
Heating Capacity									
Actual kW @ 240 volts	4.8	7.3	9.8	4.8	7.3	9.8	4.8	7.3	9.8
BTU/h @ 240 volts	16,390	24,925	33,460	16,390	24,925	33,460	16,390	24,925	33,460
Blower									
Diameter	10"	10"	10"	9"	9"	9"	10"	10"	10"
Width	8"	8"	8"	8"	8"	8"	8"	8"	8"
Coil Drain Connection FPT	3/4"	3/4"	3/4"	3/4"	3/4"	3/4"	3/4"	3/4"	3/4"
Lineset Connection Size									
Liquid	3/8"	3/8"	3/8"	3/8"	3/8"	3/8"	3/8"	3/8"	3/8"
Suction	3/4"	3/4"	3/4"	3/4"	3/4"	3/4"	3/4"	3/4"	3/4"
Electrical Data									
Min. Circuit Ampacity*	30.1/26.8	43.1/38.1	56.2/49.4	27.0/23.6	40.0/34.9	53.0/46.2	30.1/26.8	43.1/38.1	56.2/49.4
Max. Overcurrent Device (amps)*	35/30	45/40	60/50	30/25	40/35	60/50	35/30	45/40	60/50
Minimum VAC	197	197	197	197	197	197	197	197	197
Maximum VAC	253	253	253	253	253	253	253	253	253
Blower Motor									
FLA	4.1	4.1	4.1	1.58	1.58	1.58	4.1	4.1	4.1
HP	1/2	1/2	1/2	1/3	1/3	1/3	1/2	1/2	1/2
Ship Weight (lbs)	96	96	96	96	96	96	96	96	96

PRODUCT SPECIFICATIONS

AWUF[18-24]**16B*

	AWUF180516B*	AWUF180816B*	AWUF240316B*	AWUF240516B*	AWUF240816B*	AWUF241016B*
Heating Capacity						
Actual kW @ 240 volts	4.8	7.3	3.0	4.8	7.3	9.8
BTU/h @ 240 volts	16,390	24,925	10,240	16,390	24,925	33,460
Blower						
Diameter	9"	9"	10"	10"	10"	10"
Width	6"	6"	6"	6"	6"	6"
Coil Drain Connection FPT	3/4"	3/4"	3/4"	3/4"	3/4"	3/4"
Lineset Connection Size						
Liquid	3/8"	3/8"	3/8"	3/8"	3/8"	3/8"
Suction	5/8"	5/8"	5/8"	5/8"	5/8"	5/8"
Electrical Data						
Min. Circuit Ampacity*	26.6/23.3	39.6/34.6	15.1/17.3	26.7/23.3	39.7/34.2	52.7/45.6
Max. Overcurrent Device (amps)*	30/25	40/35	20/20	30/30	40/40	60/50
Minimum VAC	197	197	197	197	197	197
Maximum VAC	253	253	253	253	253	253
Blower Motor						
FLA	1.30	1.30	1.30	1.35	1.35	1.35
HP	1/5	1/5	1/5	1/5	1/5	1/5
Ship Weight (lbs)	84	84	84	84	84	84

* @ 240V/208V

BLOWER PERFORMANCE DATA

AWUF

Model	Speed	CFM delivered against External Static Pressure				
		0.1"	0.2"	0.3"	0.4"	0.5"
AWUF18XX1/16A*	High	750	730	690	650	595
	Low	710	700	690	635	585
AWUF18XX16B*	High	755	715	670	615	545
	Low	740	700	655	595	535
AWUF24XX1/16A*	High	880	845	810	770	735
	Low	845	815	780	745	705
AWUF24XX16B*	High	900	870	835	795	760
	Low	865	835	800	765	725
AWUF30XX1/16A*	High	1250	1195	1135	1085	1010
	Low	1110	1055	1020	955	905
AWUF30XX16B*	High	1255	1120	1100	1020	950
	Low	1115	1010	990	900	820
AWUF310516XX	T5	875	865	830	805	765
	T4	1005	975	945	920	890
	T3	840	795	785	745	700
	T2	645	615	550	500	445
	T1	645	615	550	500	445
AWUF310816XX/ AWUF321016XX	T5	1090	1065	1040	1015	985
	T4	1005	975	945	920	890
	T3	840	795	785	745	700
	T2	645	615	550	500	445
	T1	645	615	550	500	445
AWUF36XX1/16A*	High	1280	1190	1110	1010	930
	Low	1170	1100	1030	950	890
AWUF36XX16B*	High	1215	1145	1070	985	890
	Low	1120	1065	1000	915	820
AWUF37XX16A*	High	1326	1284	1232	1181	1115
	Low	1086	1061	1028	996	950
AWUF37XX16B*	T5	1385	1205	1130	1045	950
	T4	1235	1180	1115	1040	955
	T3	1165	1120	1075	1025	945
	T2	1050	1010	970	930	860
	T1	1050	1010	970	930	860

Note:

Assumes dry coil with filter in place; SCFM correction for wet coil = 4% (208V/240V)

WARNING

HIGH VOLTAGE!
DISCONNECT ALL POWER BEFORE SERVICING OR INSTALLING THIS UNIT. MULTIPLE POWER SOURCES MAY BE PRESENT. FAILURE TO DO SO MAY CAUSE PROPERTY DAMAGE, PERSONAL INJURY OR DEATH.

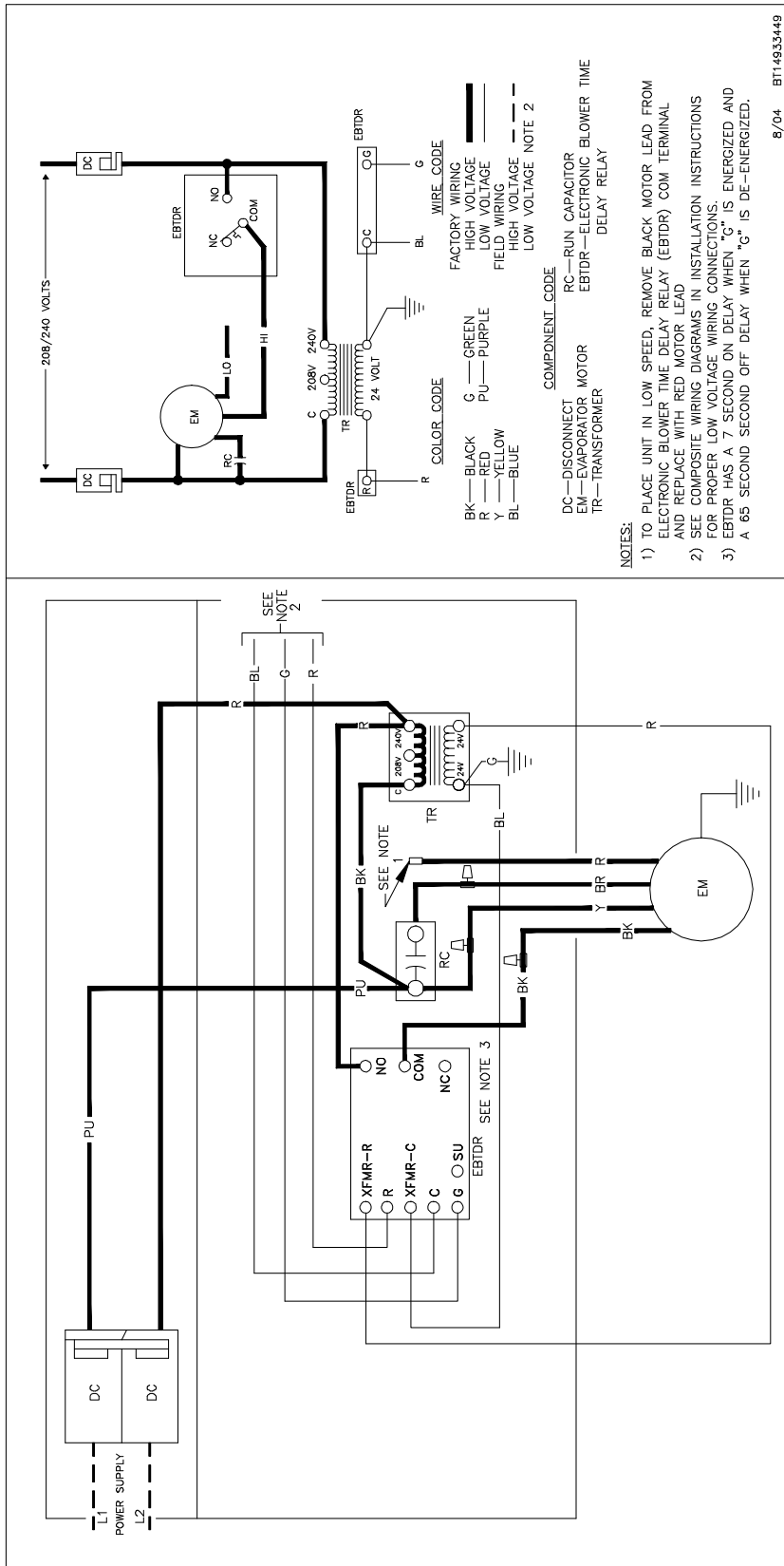

8/04 BT149.33449

Wiring is subject to change. Always refer to the wiring diagram on the unit for the most up-to-date wiring.

WIRING DIAGRAMS

ADPF, ARPF, ARUF, ATUF

WARNING

HIGH VOLTAGE!
DISCONNECT ALL POWER BEFORE SERVICING OR INSTALLING THIS UNIT. MULTIPLE POWER SOURCES MAY BE PRESENT. FAILURE TO DO SO MAY CAUSE PROPERTY DAMAGE, PERSONAL INJURY OR DEATH.

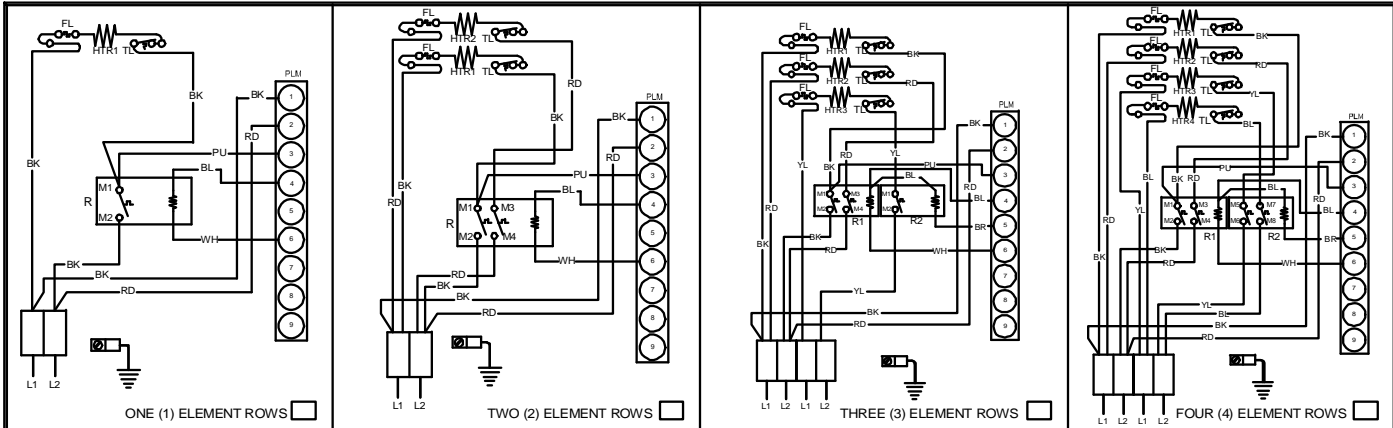

NOTE: WHEN INSTALLING HEATER KIT, ENSURE SPEED TAP DOES NOT EXCEED MINIMUM BLOWER SPEED (MBS) SPECIFIED FOR THE AIRHANDLER/HEAT ER KIT COMBINATION ON THIS UNIT'S S&R PLATE. AFTER INSTALLING OPTIONAL HEAT KIT, MARK AN "X" IN THE PROVIDED ABOVE. MARK ACCORDING TO NUMBER OF HEATER ELEMENT ROWS INSTALLED. NO MARK INDICATES NO HEAT KIT INSTALLED.

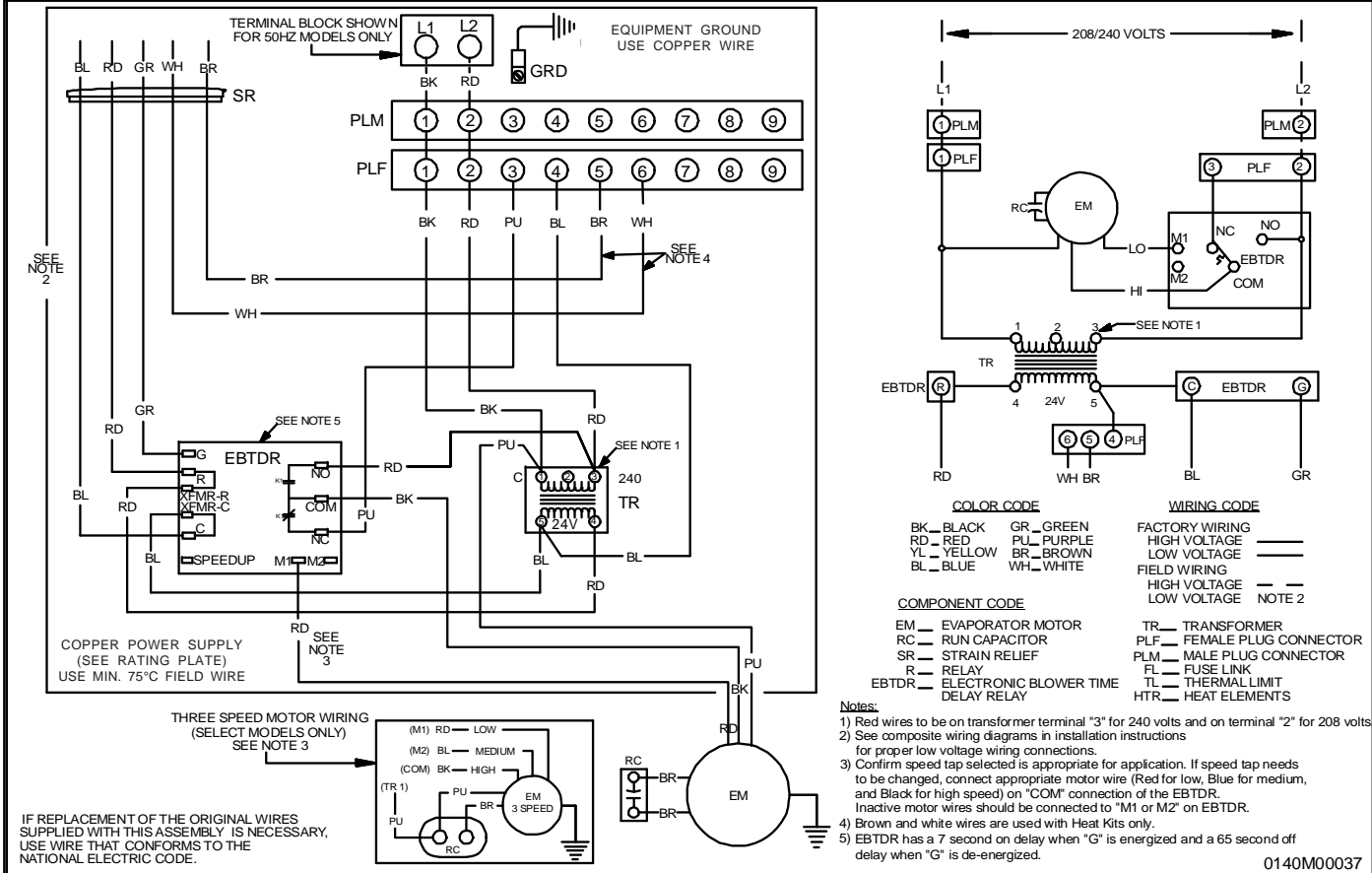

0140M00037

Wiring is subject to change. Always refer to the wiring diagram on the unit for the most up-to-date wiring.

WIRING DIAGRAMS

ADPF, ARPF, ARUF, ATUF

WARNING HIGH VOLTAGE!
 DISCONNECT ALL POWER BEFORE SERVICING OR INSTALLING THIS UNIT. MULTIPLE POWER SOURCES MAY BE PRESENT. FAILURE TO DO SO MAY CAUSE PROPERTY DAMAGE, PERSONAL INJURY OR DEATH.

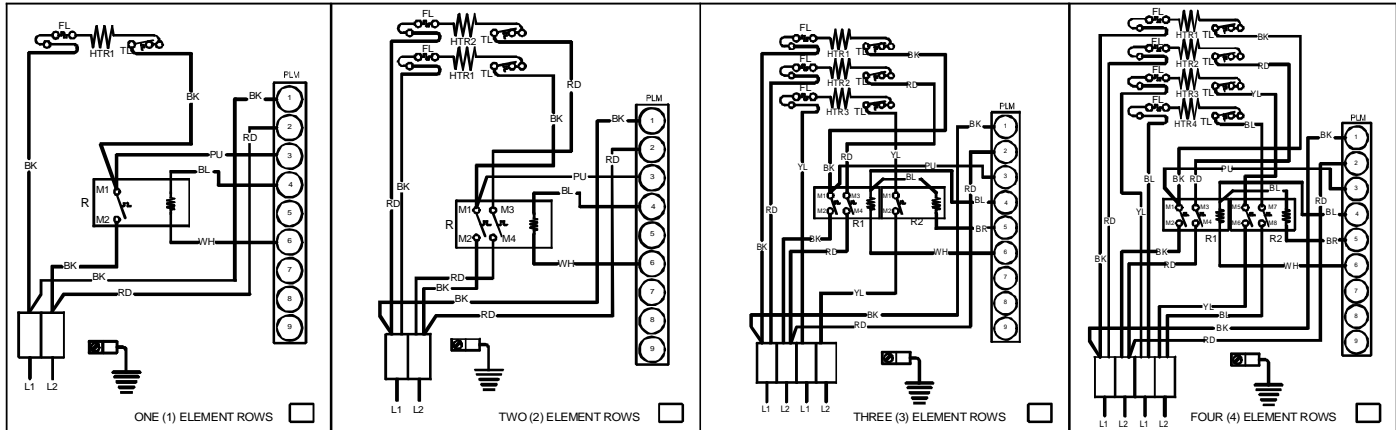

NOTE: WHEN INSTALLING HEATER KIT, ENSURE SPEED TAP DOES NOT EXCEED MINIMUM BLOWER SPEED (MBS) SPECIFIED FOR THE AIRHANDLER/HEATER KIT COMBINATION ON THIS UNIT'S S&R PLATE. AFTER INSTALLING OPTIONAL HEAT KIT, MARK AN "X" IN THE PROVIDED ABOVE. MARK ACCORDING TO NUMBER OF HEATER ELEMENT ROWS INSTALLED. NO MARK INDICATES NO HEAT KIT INSTALLED.

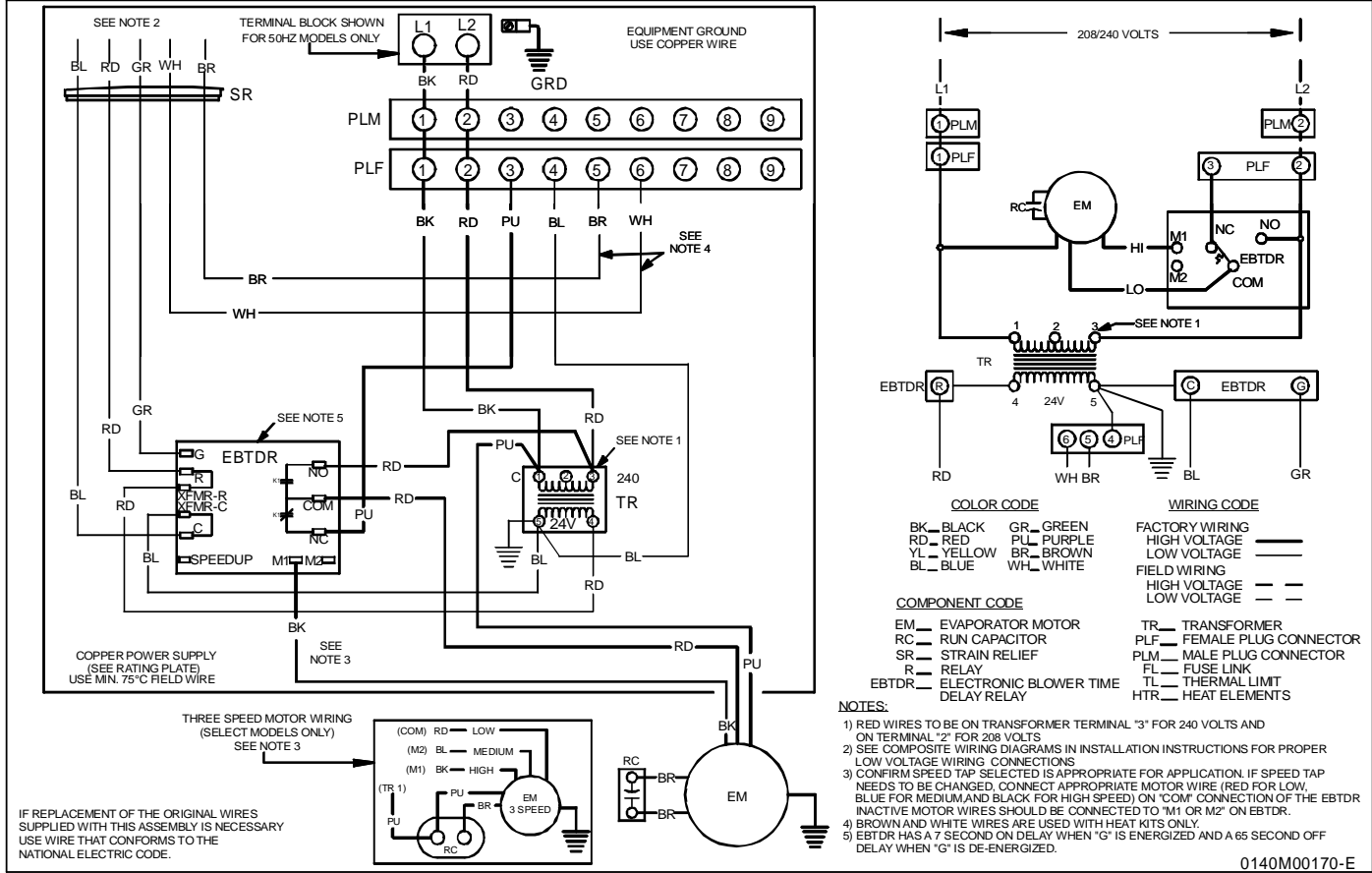

0140M00170-E

Wiring is subject to change. Always refer to the wiring diagram on the unit for the most up-to-date wiring.

WIRING DIAGRAMS

AEPF

WARNING

HIGH VOLTAGE! DISCONNECT ALL POWER BEFORE SERVICING OR INSTALLING THIS UNIT. MULTIPLE POWER SOURCES MAY BE PRESENT. FAILURE TO DO SO MAY CAUSE PROPERTY DAMAGE, PERSONAL INJURY OR DEATH.

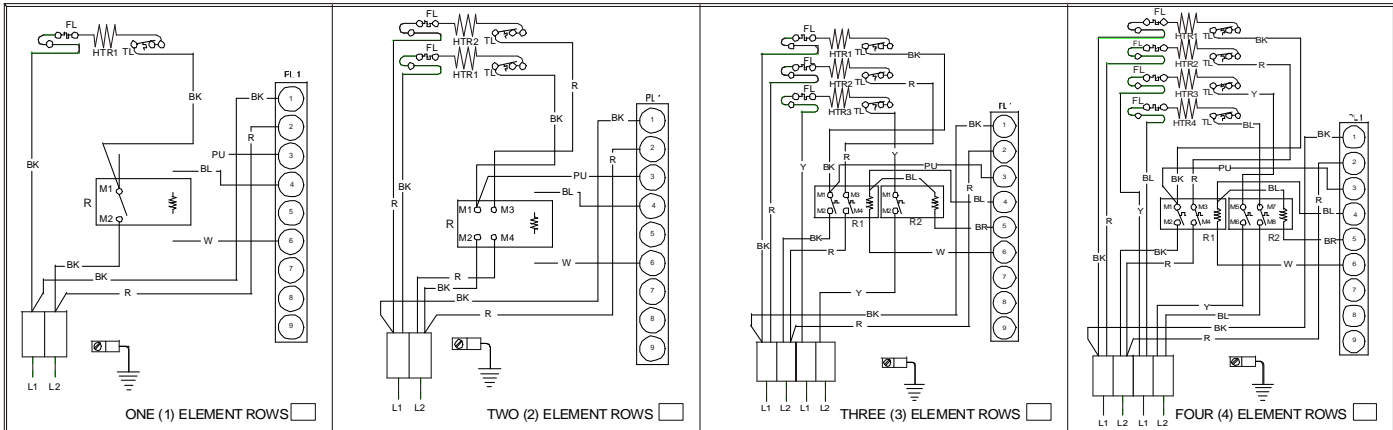

AFTER INSTALLING OPTIONAL HEAT KIT, MARK AN "X" IN THE PROVIDED ABOVE.
 MARK ACCORDING TO NUMBER OF HEATER ELEMENT ROWS INSTALLED
 NO MARK INDICATES NO HEAT KIT INSTALLED

* SEE NOTE 7
LOW VOLTAGE FIELD CONNECTION BOX

TO CONDENSER: Y, C, O, W2, W1, C, Y1, Y/Y2, O

TO THERMOSTAT: R, BL, W, BR, BL, PU, Y, G, O

208/240 VOLTS

TO LOW VOLTAGE TERMINAL BOARD

24 VOLT

COLOR CODE		WIRING CODE
W _ WHITE	G _ GREEN	FACTORY WIRING
BK _ BLACK	PU _ PURPLE	HIGH VOLTAGE
R _ RED	BR _ BROWN	LOW VOLTAGE
Y _ YELLOW	O _ ORANGE	FIELD WIRING
BL _ BLUE	PK _ PINK	HIGH VOLTAGE
		LOW VOLTAGE

COMPONENT CODE	
EM _ EVAPORATOR MOTOR	TL _ THERMAL LIMIT
PL _ PLUG	HTR _ HEAT ELEMENT
PJ2, PJ4, PJ6 _ PROGRAM JUMPER	R _ RELAY
VSTB _ VARIABLE SPEED TERMINAL BOARD	TR _ TRANSFORMER
FL _ FUSE LINK	

NOTES:

1. FOR HEAT PUMP APPLICATIONS REMOVE ORANGE JUMPER WIRE BETWEEN O & Y1.
2. FOR TWO STAGE ELECTRIC HEAT APPLICATIONS CUT PJ4. (USE ONLY ON #5 & 20 KW MODELS).
3. FOR OUTDOOR THERMOSTAT OPERATION OF SECOND STAGE HEAT, CUT PJ2 & ADD OT18-60 TO OTC & OT2.
4. FOR SINGLE STAGE COOLING APPLICATIONS CONNECT THERMOSTAT TO Y/Y2 ONLY, TAPE OR REMOVE Y1 CONNECTION. CONNECT CONDENSING UNIT TO YCON & C.
5. WHEN HUMIDISTAT IS PROVIDED CUT PJ6. THERMOSTAT OPENS ON HUMIDITY RISE.
6. RED WIRES TO BE ON TRANSFORMER TERMINAL 3 FOR 240 VOLTS AND ON TERMINAL 2 FOR 208 VOLTS.
7. SEE COMPOSITE WIRING DIAGRAMS IN INSTALLATION INSTRUCTIONS FOR PROPER LOW VOLTAGE CONNECTIONS AND DETAILS ON COMPATIBLE THERMOSTATS AND THEIR CONNECTIONS.
8. DISCARD ORIGINAL "PL1" PLUG CONNECTOR WHEN INSTALLING OPTIONAL HEAT KIT.

CONTROLS SHOWN WITH UTILITIES IN 'ON' POSITION AND THERMOSTAT IN 'OFF' POSITION.
 IF REPLACEMENT OF THE ORIGINAL WIRES SUPPLIED WITH THIS ASSEMBLY IS NECESSARY, USE 105°C, WIRE, SIZE TO CONFORM TO THE NATIONAL ELECTRIC CODE.

0140A0000P

Wiring is subject to change. Always refer to the wiring diagram on the unit for the most up-to-date wiring.

WIRING DIAGRAMS

AEPF*****CA



WARNING

HIGH VOLTAGE!
DISCONNECT ALL POWER BEFORE SERVICING OR INSTALLING THIS UNIT. MULTIPLE POWER SOURCES MAY BE PRESENT. FAILURE TO DO SO MAY CAUSE PROPERTY DAMAGE, PERSONAL INJURY OR DEATH.



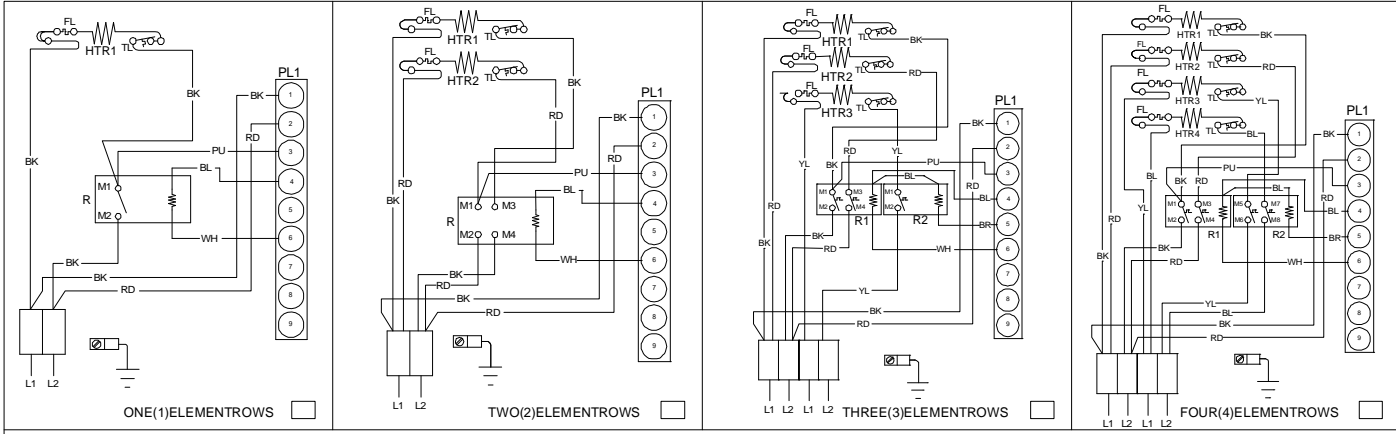

AFTER INSTALLING OPTIONAL HEAT KIT, MARK "X" IN THE PROVIDED ABOVE.
 MARK ACCORDING TO NUMBER OF HEATER ELEMENT ROWS INSTALLED
 NO MARK INDICATES NO HEAT KIT INSTALLED

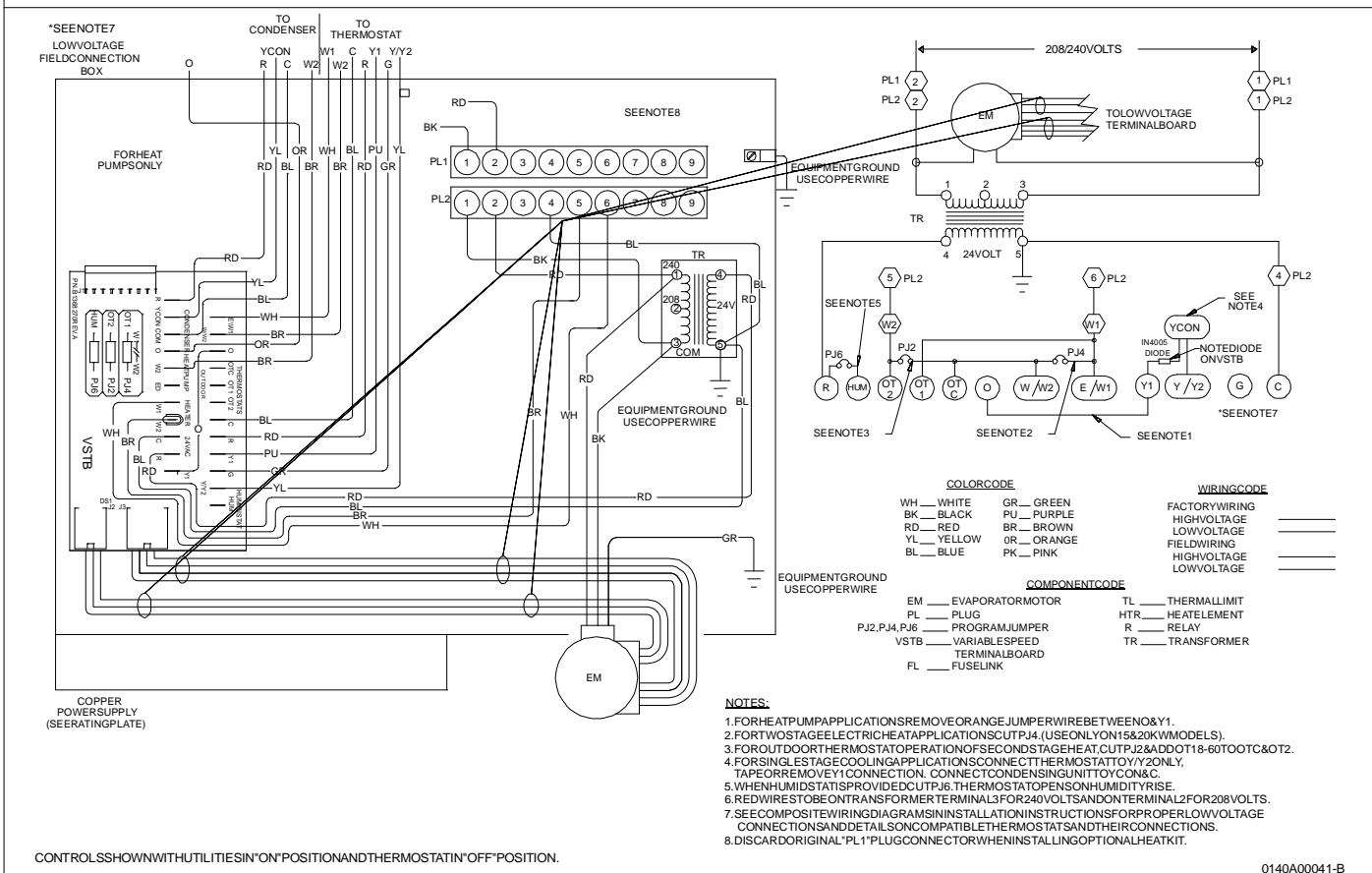

Wiring is subject to change. Always refer to the wiring diagram on the unit for the most up-to-date wiring.

WARNING

HIGH VOLTAGE!
DISCONNECT ALL POWER BEFORE SERVICING OR INSTALLING THIS UNIT. MULTIPLE POWER SOURCES MAY BE PRESENT. FAILURE TO DO SO MAY CAUSE PROPERTY DAMAGE, PERSONAL INJURY OR DEATH.

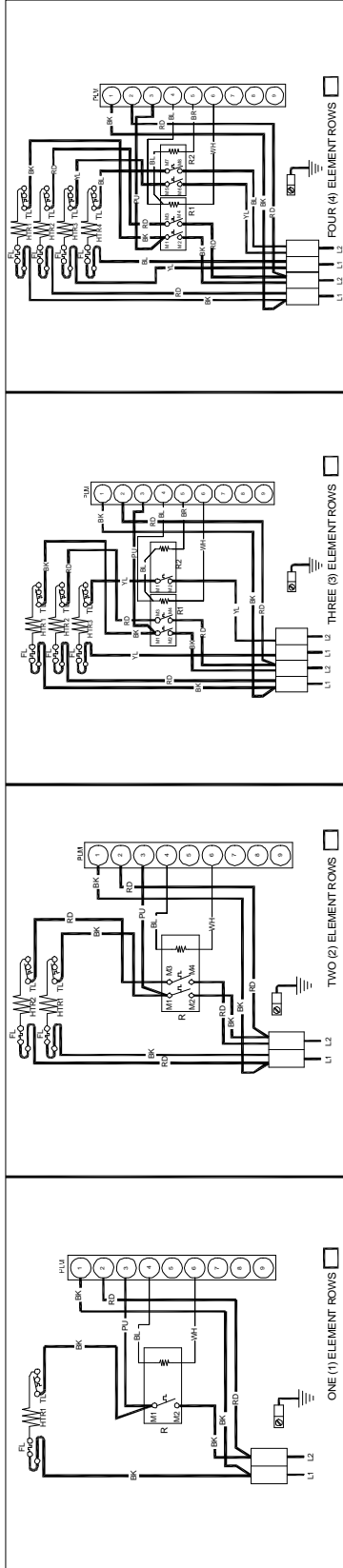

NOTE: WHEN INSTALLING HEATER KIT, ENSURE SPEED TAP DOES NOT EXCEED MINIMUM BLOWER SPEED (MBS) SPECIFIED FOR THE AIRHANDLER/HEAT ER KIT COMBINATION ON THIS UNIT'S S&R PLATE. AFTER INSTALLING OPTIONAL HEAT KIT, MARK AN "X" IN THE PROVIDED ABOVE. MARK ACCORDING TO NUMBER OF HEATER ELEMENT ROWS INSTALLED. NO MARK INDICATES NO HEAT KIT INSTALLED.

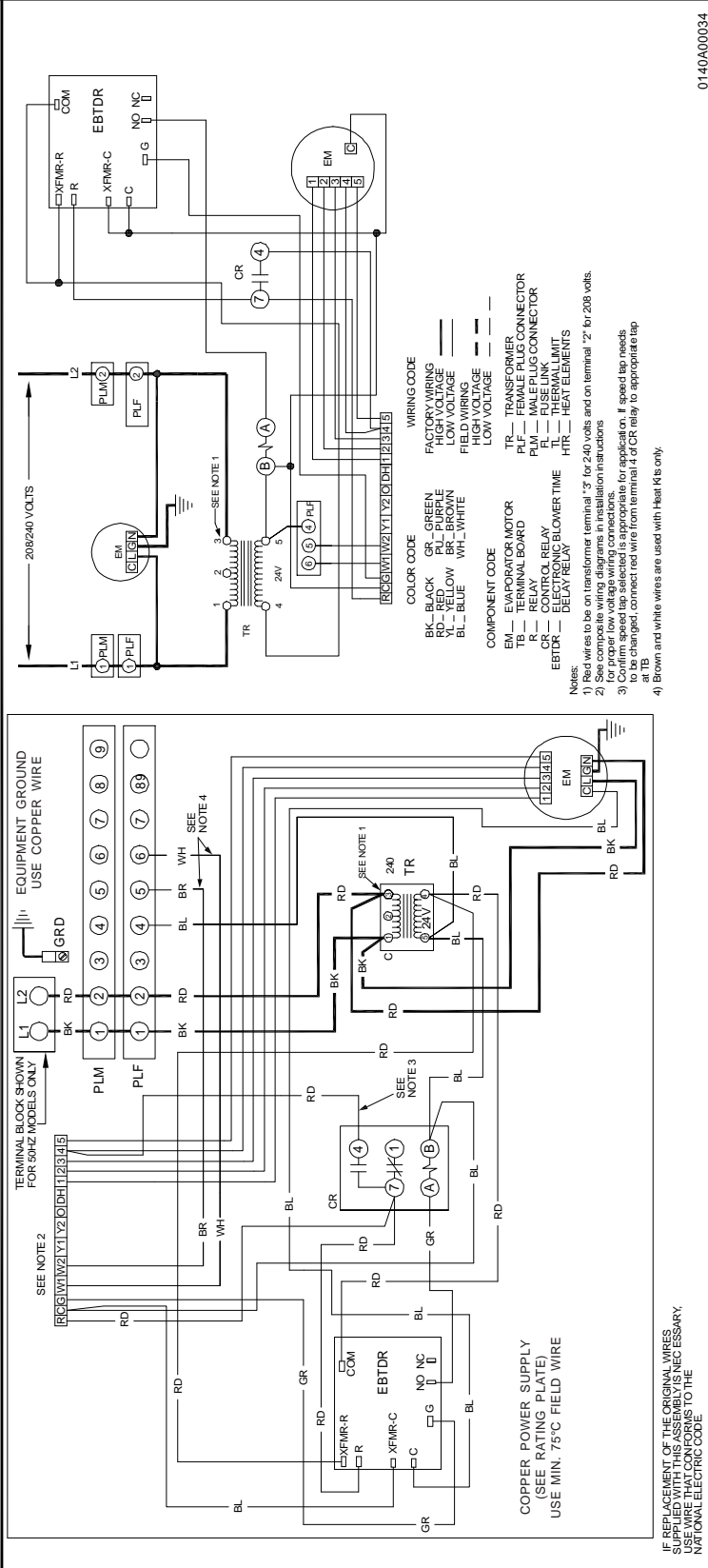

0140A00034

Wiring is subject to change. Always refer to the wiring diagram on the unit for the most up-to-date wiring.

WARNING

HIGH VOLTAGE!
DISCONNECT ALL POWER BEFORE SERVICING OR INSTALLING THIS UNIT. MULTIPLE POWER SOURCES MAY BE PRESENT. FAILURE TO DO SO MAY CAUSE PROPERTY DAMAGE, PERSONAL INJURY OR DEATH.

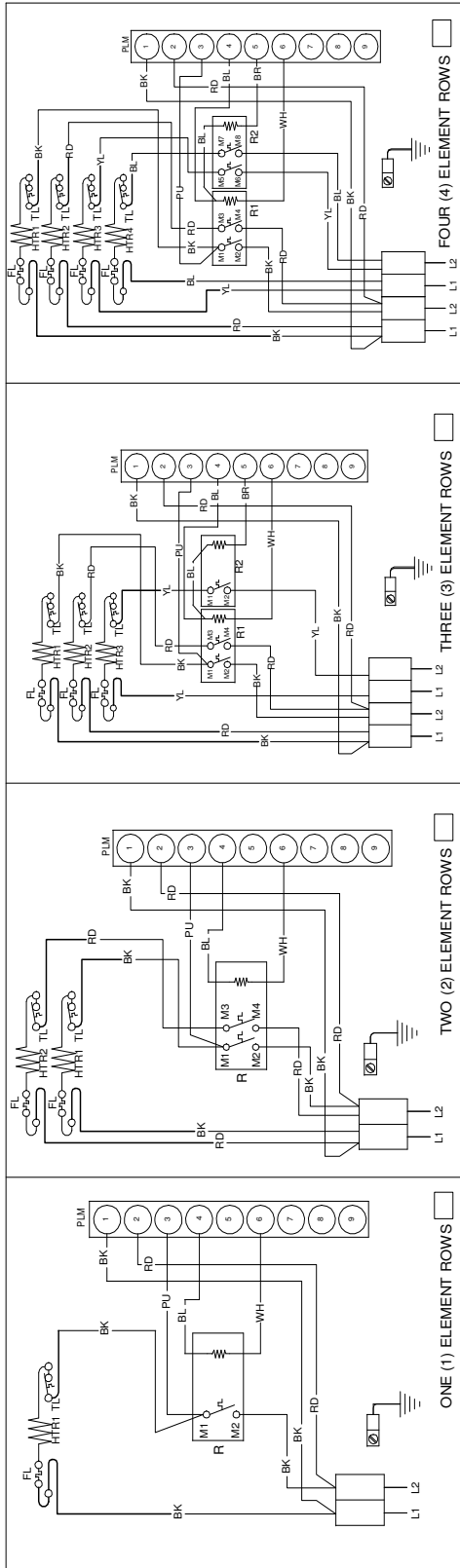

NOTE: WHEN INSTALLING HEATER KIT, ENSURE SPEED TAP DOES NOT EXCEED MINIMUM BLOWER SPEED (MBS) SPECIFIED FOR THE AIRHANDLER/HEATER KIT COMBINATION ON THIS UNIT'S S&R PLATE. AFTER INSTALLING OPTIONAL HEAT KIT, MARK AN "X" IN THE PROVIDED ABOVE. MARK ACCORDING TO NUMBER OF HEATER ELEMENT ROWS INSTALLED. NO MARK INDICATES NO HEAT KIT INSTALLED.

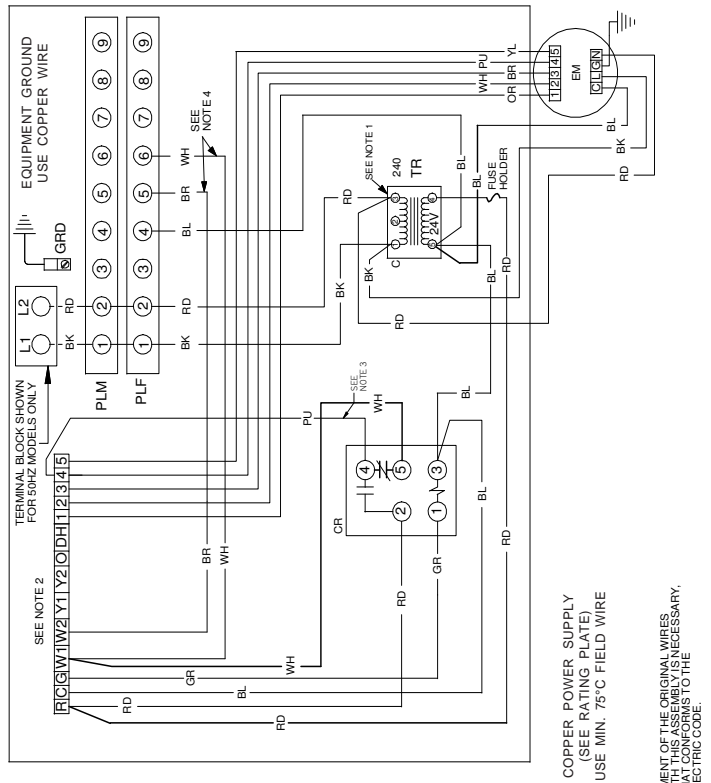
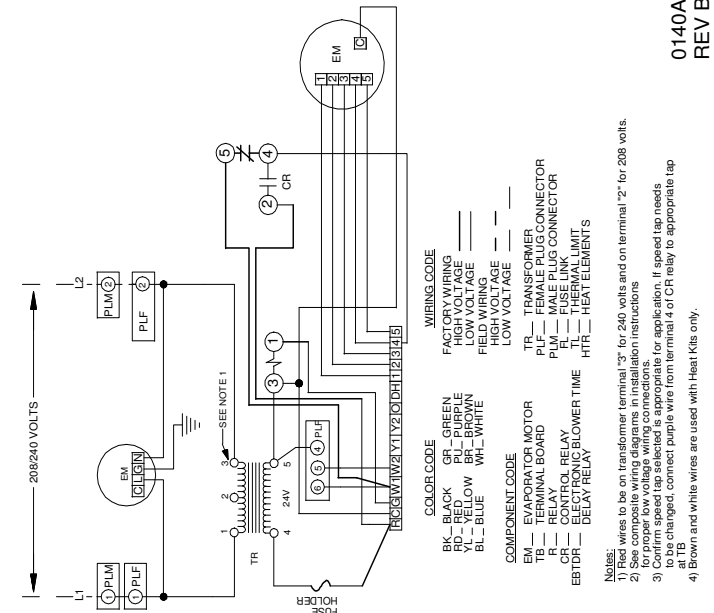

- WIRING CODE**
- FACTORY WIRING: BK - BLACK, GR - GREEN, PL - PURPLE, PU - PURPLE, YL - YELLOW, WH - WHITE
 - HIGH VOLTAGE: BK - BLACK, RD - RED, YL - YELLOW, WH - WHITE
 - LOW VOLTAGE: BK - BLACK, RD - RED, YL - YELLOW, WH - WHITE
- COLOR CODE**
- BK - BLACK, GR - GREEN, PL - PURPLE, PU - PURPLE, YL - YELLOW, WH - WHITE
 - RD - RED, YL - YELLOW, WH - WHITE
- COMPONENT CODE**
- EM - EVAPORATOR MOTOR, TR - TRANSFORMER
 - TB - TERMINAL BOARD, PLM - FEMALE PLUG CONNECTOR
 - R - RELAY, CR - CR RELAY, PLF - MALE PLUG CONNECTOR
 - EBTOR - ELECTRONIC BLOWER TIME, TL - THERMAL LIMIT
 - DELAY - DELAY RELAY, HTR - HEAT ELEMENTS

- NOTES:**
- 1) Red wires to be on transformer terminal "3" for 240 volts and on terminal "2" for 208 volts.
 - 2) See composite wiring diagrams in installation instructions.
 - 3) Confirm speed tap selected is appropriate for application. If speed tap needs to be changed, connect purple wire from terminal 4 of CR relay to appropriate tap at TB.
 - 4) Brown and white wires are used with Heat Kits only.

COPPER POWER SUPPLY (SEE RATING PLATE)
USE MIN. 75°C FIELD WIRE

IF REPLACEMENT OF THE ORIGINAL WIRES IS NECESSARY, USE WIRE THAT CONFORMS TO THE NATIONAL ELECTRIC CODE.

0140A00037
REV B



WARNING

HIGH VOLTAGE!
DISCONNECT ALL POWER BEFORE SERVICING OR INSTALLING THIS UNIT. MULTIPLE POWER SOURCES MAY BE PRESENT. FAILURE TO DO SO MAY CAUSE PROPERTY DAMAGE, PERSONAL INJURY OR DEATH.



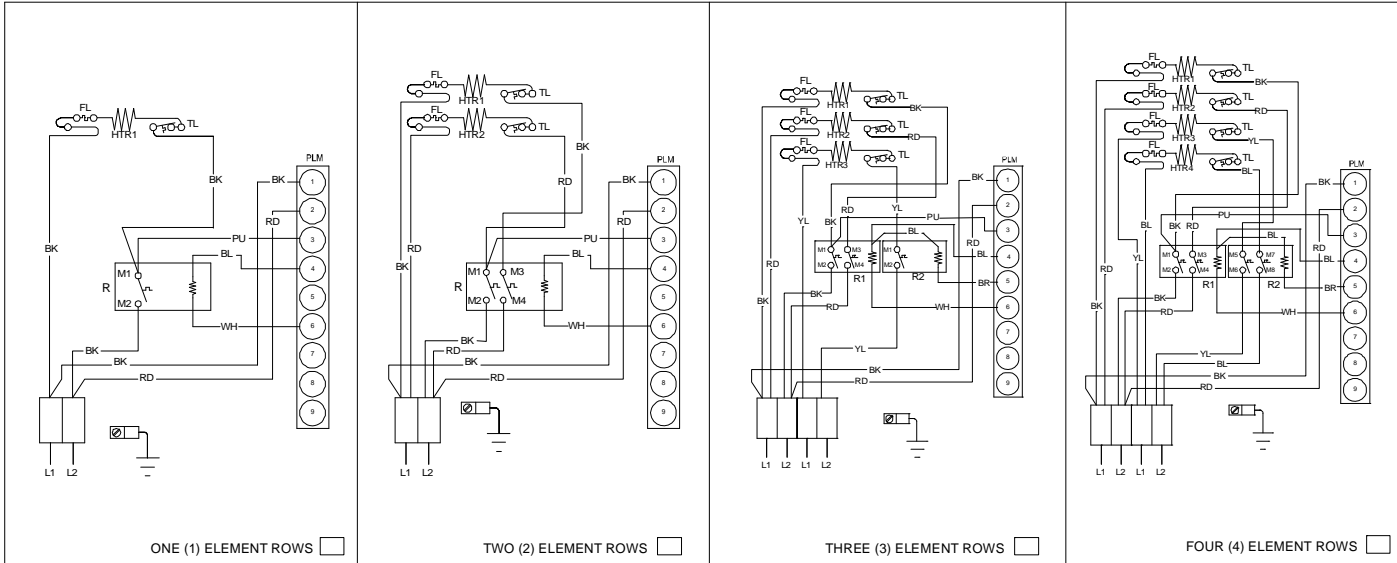

NOTE: WHEN INSTALLING HEATER KIT, ENSURE SPEED TAP DOES NOT EXCEED MINIMUM BLOWER SPEED (MBS) SPECIFIED FOR THE AIRHANDLER/HEATER KIT COMBINATION ON THIS UNIT'S S&R PLATE. AFTER INSTALLING OPTIONAL HEAT KIT, MARK A "X" IN THE PROVIDED ABOVE. MARK ACCORDING TO NUMBER OF HEATER ELEMENT ROWS INSTALLED. NO MARK INDICATES NO HEAT KIT INSTALLED.

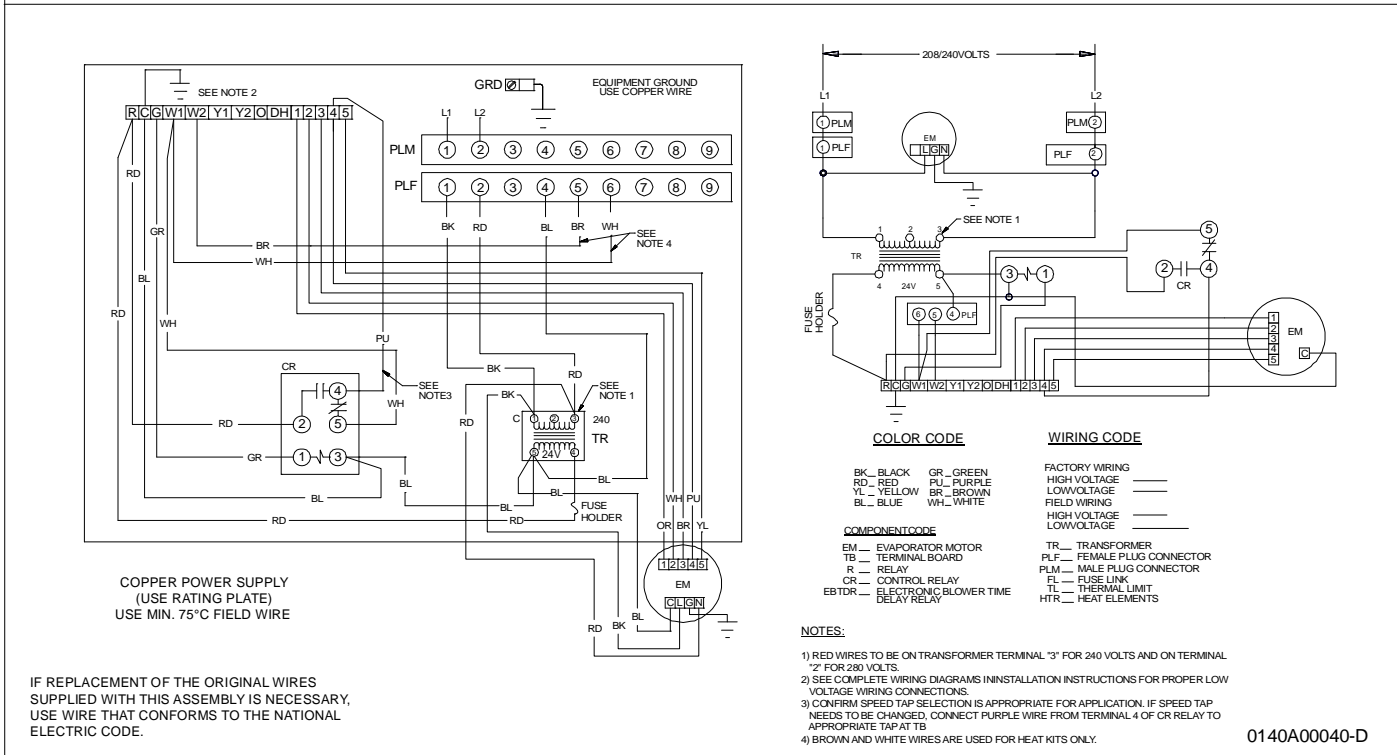

WARNING

HIGH VOLTAGE!
DISCONNECT ALL POWER BEFORE SERVICING OR INSTALLING THIS UNIT. MULTIPLE POWER SOURCES MAY BE PRESENT. FAILURE TO DO SO MAY CAUSE PROPERTY DAMAGE, PERSONAL INJURY OR DEATH.

ONE (1) ELEMENT ROWS

TWO (2) ELEMENT ROWS

THREE (3) ELEMENT ROWS

FOUR (4) ELEMENT ROWS

NOTE: WHEN INSTALLING HEATER KIT, ENSURE SPEED TAP DOES NOT EXCEED MINIMUM BLOWER SPEED (MBS) SPECIFIED FOR THE AIRHANDLER/HEATER KIT COMBINATION ON THIS UNIT'S S&R PLATE. AFTER INSTALLING OPTIONAL HEAT KIT, MARK A "X" IN THE BOX PROVIDED ABOVE. MARK ACCORDING TO NUMBER OF HEATER ELEMENT ROWS INSTALLED. NO MARK INDICATES NO HEAT KIT INSTALLED.

WIRING CODE

FACTORY WIRING _____
 HIGH VOLTAGE _____
 LOW VOLTAGE _____
 FIELD WIRING _____
 LOW VOLTAGE _____

COLOR CODE

BK - BLACK GR - GREEN
 RD - RED PU - PURPLE
 BR - BROWN BL - BLUE
 WH - WHITE

COMPONENT CODE

CR - CONTACT RELAY
 EM - EVAPORATOR MOTOR
 FL - FUSE LINK
 HTR - HEAT ELEMENTS
 PLF - FEMALE PLUG CONNECTOR
 PLM - MALE PLUG CONNECTOR
 R - RELAY
 TB - TERMINAL BOARD
 TR - TRANSFORMER
 TL - THERMAL LIMIT

NOTES:

- 1) RED WIRES TO BE ON TRANSFORMER TERMINAL '3' FOR 240 VOLTS AND ON TERMINAL '2' FOR 208 VOLTS.
- 2) SEE COMPLETE WIRING DIAGRAMS IN INSTALLATION INSTRUCTIONS FOR FUSE HOLDER (OPTIONAL).
- 3) CONFIRM SPEED TAP SELECTION IS APPROPRIATE FOR APPLICATION. IF SPEED TAP NEEDS TO BE CHANGED, CONNECT PURPLE WIRE FROM TERMINAL 4 OF CR RELAY TO APPROPRIATE TAP AT TB.
- 4) BROWN AND WHITE WIRES ARE USED FOR HEAT KITS ONLY.
- 5) FUSE: 3A, 250V, 3AG CARTRIDGE FUSE.

0140A00063-B

Wiring is subject to change. Always refer to the wiring diagram on the unit for the most up-to-date wiring.

WARNING

HIGH VOLTAGE! DISCONNECT ALL POWER BEFORE SERVICING OR INSTALLING THIS UNIT. MULTIPLE POWER SOURCES MAY BE PRESENT. FAILURE TO DO SO MAY CAUSE PROPERTY DAMAGE, PERSONAL INJURY OR DEATH.

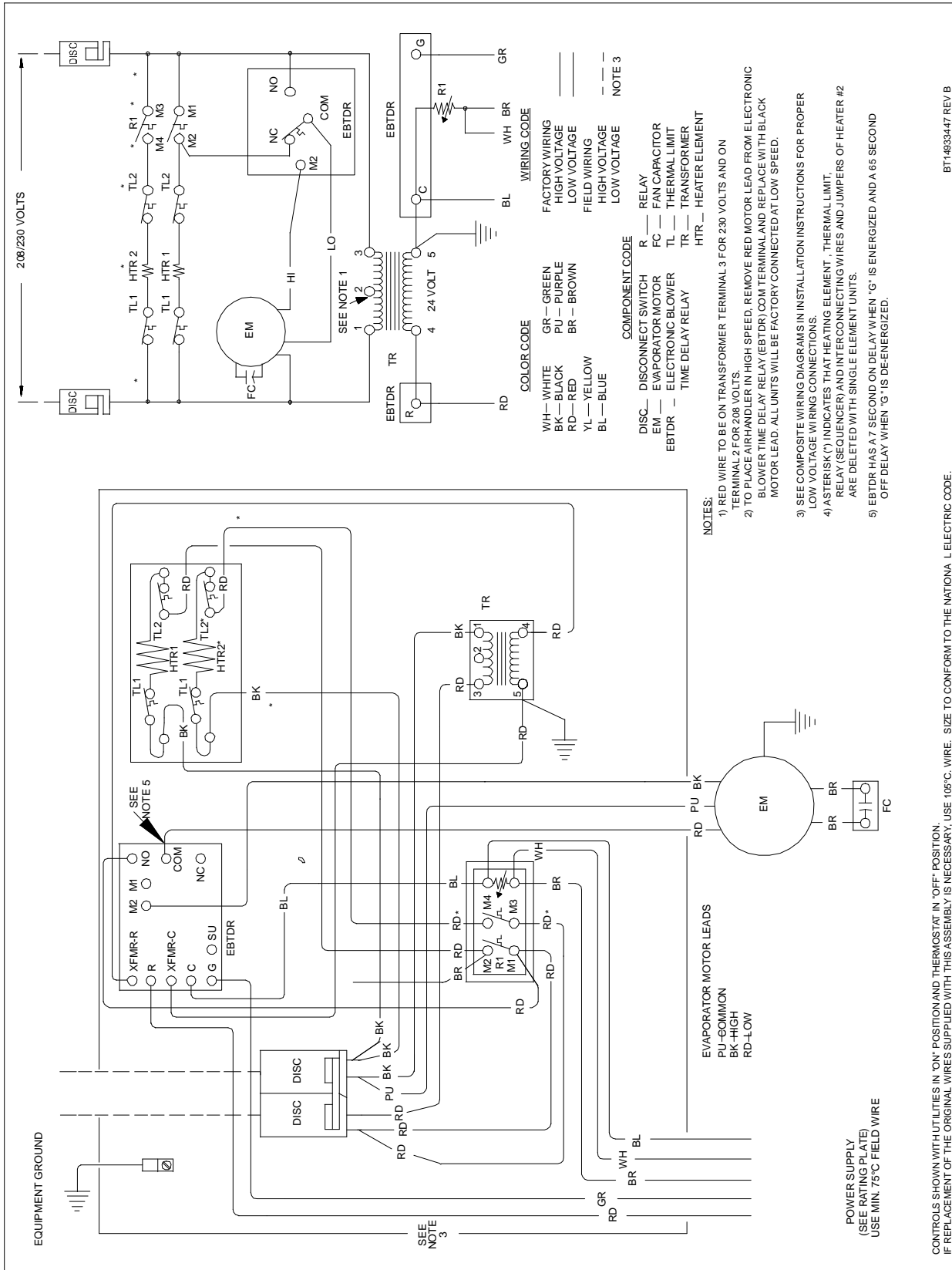

Wiring is subject to change. Always refer to the wiring diagram on the unit for the most up-to-date wiring.

WARNING

HIGH VOLTAGE!
DISCONNECT ALL POWER BEFORE SERVICING OR INSTALLING THIS UNIT. MULTIPLE POWER SOURCES MAY BE PRESENT. FAILURE TO DO SO MAY CAUSE PROPERTY DAMAGE, PERSONAL INJURY OR DEATH.

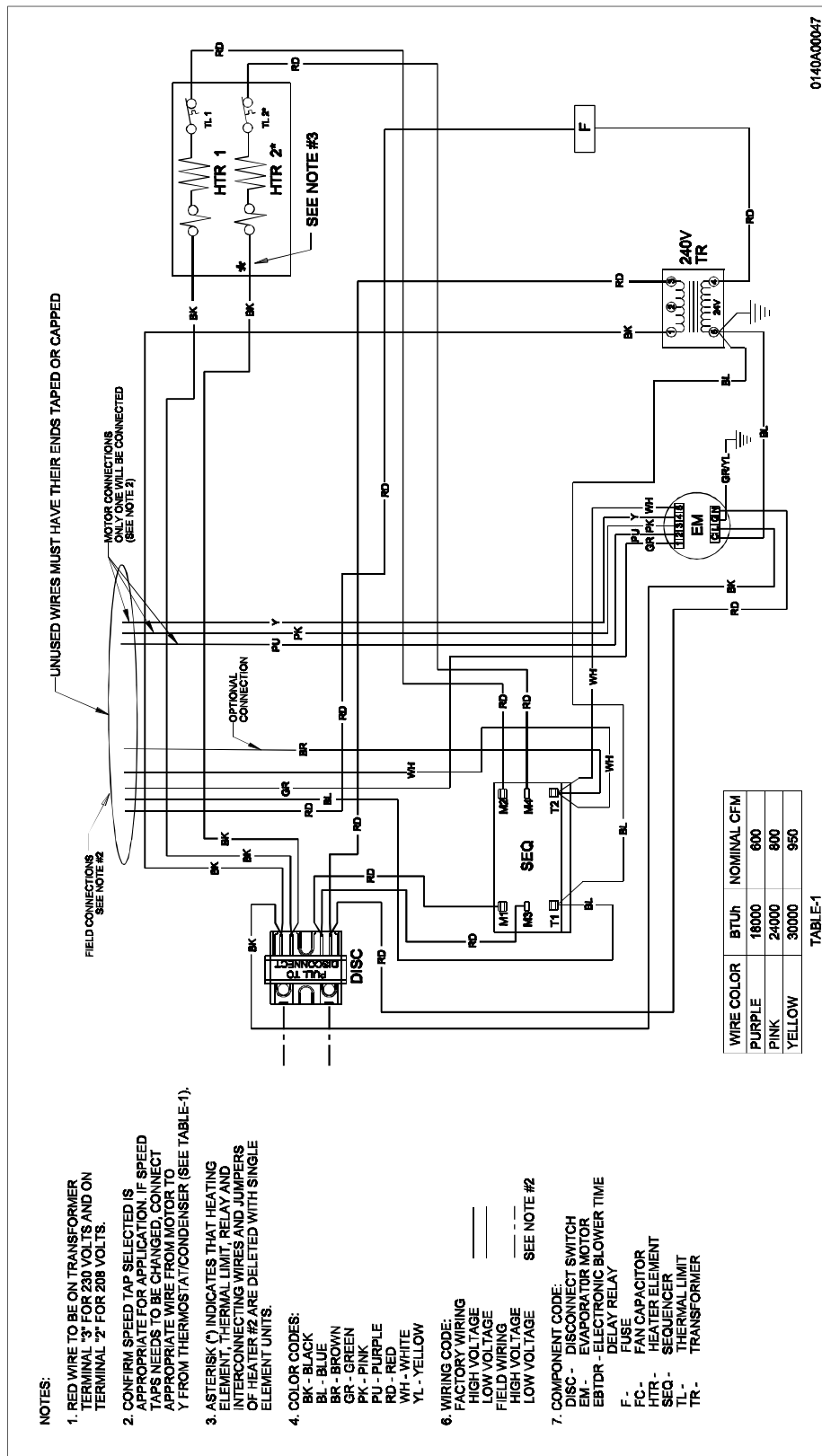

- NOTES:**
1. RED WIRE TO BE ON TRANSFORMER TERMINAL "3" FOR 230 VOLTS AND ON TERMINAL "2" FOR 208 VOLTS.
 2. CONFIRM SPEED TAP SELECTED IS APPROPRIATE FOR APPLICATION. IF SPEED TAPS NEEDS TO BE CHANGED, CONNECT APPROPRIATE WIRE FROM MOTOR TO Y FROM THERMOSTAT/CONDENSER (SEE TABLE-1).
 3. ASTERISK (*) INDICATES THAT HEATING ELEMENT, THERMAL LIMIT, RELAY AND INTERCONNECTING WIRES AND JUMPERS ON HEATER #2 ARE DELETED WITH SINGLE ELEMENT UNITS.
 4. COLOR CODES:
BK - BLACK
BL - BLUE
BR - BROWN
GR - GREEN
PK - PINK
PU - PURPLE
RD - RED
WH - WHITE
YL - YELLOW
 6. WIRING CODE:
HIGH VOLTAGE
LOW VOLTAGE
FIELD WIRING
HIGH VOLTAGE
LOW VOLTAGE
 7. COMPONENT CODE:
DISC - DISCONNECT SWITCH
EM - EVAPORATOR MOTOR
EBTDR - ELECTRONIC BLOWER TIME DELAY RELAY
F - FUSE
FC - FAN CAPACITOR
HTR - HEATER ELEMENT
SEQ - SEQUENCER
THER - THERMAL LIMIT
TR - TRANSFORMER

WIRE COLOR	BTUH	NOMINAL CFM
PURPLE	18000	600
PINK	24000	800
YELLOW	30000	950

TABLE-1

Wiring is subject to change. Always refer to the wiring diagram on the unit for the most up-to-date wiring.



WARNING

HIGH VOLTAGE!
DISCONNECT ALL POWER BEFORE SERVICING OR INSTALLING THIS UNIT. MULTIPLE POWER SOURCES MAY BE PRESENT. FAILURE TO DO SO MAY CAUSE PROPERTY DAMAGE, PERSONAL INJURY OR DEATH.



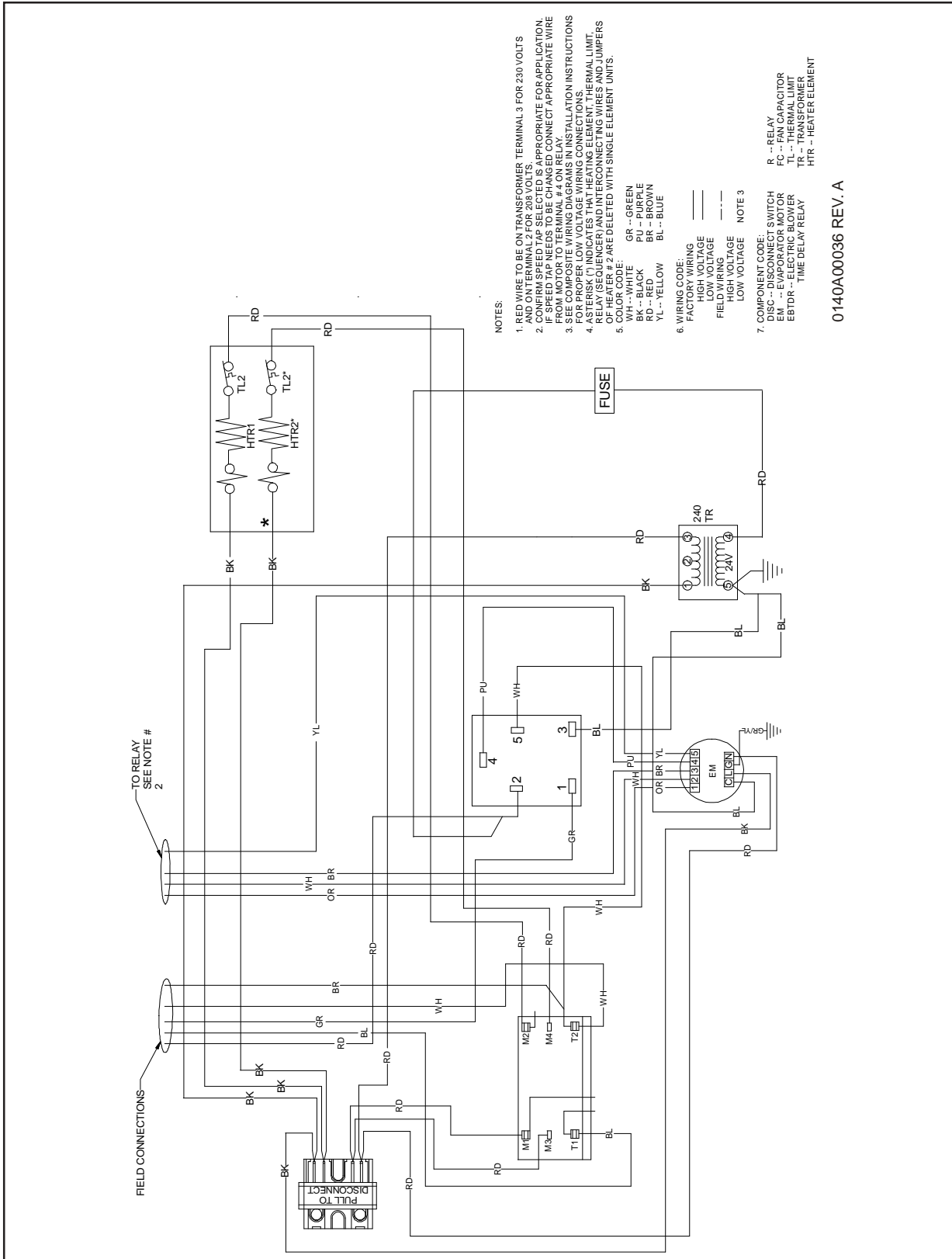

- NOTES:**
1. RED WIRE TO BE ON TRANSFORMER TERMINAL 3 FOR 230 VOLTS AND ON TERMINAL 2 FOR 208 VOLTS.
 2. CONFIRM SPEED/TAP SELECTED IS APPROPRIATE FOR APPLICATION. SEE MOTOR SPEED TAP SELECTED ON MOTOR. CONNECT APPROPRIATE WIRE FROM MOTOR TO TERMINAL #4 ON RELAY.
 3. SEE COMPOSITE WIRING DIAGRAMS IN INSTALLATION INSTRUCTIONS FOR PROPER LOW VOLTAGE WIRING CONNECTIONS.
 4. ASTERISK (*) INDICATES THAT HEATING ELEMENT, THERMAL LIMIT, THERMAL SWITCH, OR EVAPORATOR MOTOR IS TO BE CONNECTED TO THE WIRING OF HEATER #2. ARE DELETED WITH SINGLE ELEMENT UNITS.
 5. COLOR CODE:
 - WH -- WHITE
 - GR -- GREEN
 - BK -- BLACK
 - PU -- PURPLE
 - RD -- RED
 - BR -- BROWN
 - YL -- YELLOW
 - BL -- BLUE
 6. WIRING CODE:
 - SOLID LINE --- FACTORY WIRING
 - DASHED LINE --- HIGH VOLTAGE
 - DOTTED LINE --- LOW VOLTAGE
 - DASH-DOTTED LINE --- FIELD WIRING
 - DOTTED-DASHED LINE --- HIGH VOLTAGE
 - SOLID-DOTTED LINE --- LOW VOLTAGE
 7. COMPONENT CODE:
 - R -- RELAY
 - FC -- FAN CAPACITOR
 - TL -- THERMAL LIMIT
 - TR -- TRANSFORMER
 - EBTDR -- TIME DELAY RELAY
 - HTR -- HEATER ELEMENT
- 0140A00036 REV. A

Wiring is subject to change. Always refer to the wiring diagram on the unit for the most up-to-date wiring.