



# MODEL SC401 DUAL CYLINDER SCALE

## INSTALLATION/SERVICE MANUAL



The entire contents of this manual **MUST** be read and understood prior to installing and operating this equipment.

Do not discard this manual upon completion of the installation as this manual contains information essential to the safe handling, operation, and maintenance of this equipment.

 **chlorinators incorporated**

1044 SE Dixie Cutoff Road, Stuart, FL 34994 USA

Tel: (772) 288-4854 • Fax: (772) 287-3238 • [www.regalchlorinators.com](http://www.regalchlorinators.com) • Email: [regal@regalchlorinators.com](mailto:regal@regalchlorinators.com)

# CHLORINATORS INCORPORATED ONE (1) YEAR LIMITED WARRANTY

Chlorinators Incorporated (hereinafter called "C.I.") sets forth the following warranties with respect to its REGAL Model SC401 Dual Cylinder Scale. This warranty does not apply to the purchase of spare parts or other services performed by C.I. or its authorized Dealers. This represents the entire agreement between C.I. and Buyer (also referred to as "end-user") and shall apply unless modified in writing and signed by a C.I. Officer, and this warranty and its intended terms shall supersede any prior negotiations, correspondence, understandings, or agreements, written or oral. The Buyer agrees to and accepts all terms of this warranty by its contracting for or acceptance of C.I.'s products, and forms or other documents or statements issued by Buyer or any other person shall not modify or otherwise affect any of the following terms. Buyer should be aware that reseller must rely entirely upon Chlorinators Incorporated's warranties, or assume their own responsibility.

**The following states C.I.'s entire warranty and represents Buyer's exclusive remedy with respect to its product. Such warranties are expressly given in lieu of any other warranty, expressed or implied, including but not limited to those of merchantability and fitness for a particular purpose. This expressed warranty or any other warranty implied by law shall not cover defects due to accident, improper use, or non-compliance with C.I.'s operating and maintenance, assembly, installation manual and instructions.**

Recommendations and advice as to specifications, capabilities, design, installation, engineering, application, and use of products are provided as an accommodation, and are intended only as suggestions. C.I. assumes no liability for such recommendations and advice, and they are not to be construed as constituting any warranty, expressed or implied.

## TERMS OF WARRANTY

C.I. warrants its REGAL Model SC401 Dual Cylinder Scale for a period of one (1) year from date of shipment from C.I. Date of shipment from the factory shall be determined solely on the basis of the serial code affixed to the SC401's enclosure. The serial number contains a date code. All serial numbers are also registered by Chlorinators Incorporated as to date of shipment, model number, accessories, options, and billing name. If the serial number is missing, defaced, changed, or in any way rendered unreadable, Chlorinators Incorporated shall, at its option, have the right to declare the warranty void. If the serial number does not match the registered model number as to, but not limited to, such items as accessories or options, the same shall apply.

The warranty shall apply against material defects in components and workmanship occurring in the course of manufacture. Buyer's sole remedy for breach of said warranty shall be, at C.I.'s option, either repair or replacement of any unit which is received by C.I. at its plant in Stuart, Florida, (shipping charges prepaid by buyer) within the time period set forth above and which is found by C.I. to be defective by reason of manufacture.

**Notwithstanding the foregoing, C.I. shall not be liable to Buyer for damages, including personal injury or death to any person or persons, or claims of any kind by a third party, or property damage, or loss of business or profits. In no event shall C.I. be liable to Buyer for consequential or accidental damages of any kind, even if C.I. was aware of the possibility of such damages. There are no remedies except those set forth. Further, that there are no other authorized warranty repair facilities other than those at the Chlorinators Incorporated factory in Stuart, Florida.**

## EXCLUSIONS

The following are considered external environmental factors beyond the control of C.I., and which may cause damage and/or need for service which will be specifically excluded from this warranty (i.e., not a material defect in components and workmanship occurring in the course of manufacture).

1. Damage by extraneous causes such as fire, water, lightning, chemical or galvanic attack, etc.
2. Physical damage due to force, dropping, misuse, or other abuse.
3. Use other than that as described in this Instruction Manual (misapplication).
4. Repair by someone other than Chlorinators Incorporated.
5. Improperly installed.

The exclusions listed above are provided for purposes of clarification, and are not intended to, in any way, limit or eliminate other possible exclusions.

## NO OTHER WARRANTIES

Unless otherwise explicitly agreed in writing, and signed by a C.I. officer, it is understood that this is the only written warranty given by C.I. for the systems and components stated.

**The dealers or representatives of C.I. may not make verbal representations that add, modify or change the written warranties contained herein or change the extent and nature of C.I.'s liability. In no event shall C.I. be liable for direct, consequential, special, incidental or punitive damages of any kind, with respect to the product, including but not limited to those which may allegedly arise out of breach of warranty, breach of contract, negligence, strict liability, or any other law, governmental regulation, or court decision, except as provided herein.**

## GENERAL

The REGAL Model SC401 Dual Cylinder Scale has been specifically designed for the water and waste water industry for the weighing of 150 lb. chlorine gas cylinders.

The REGAL Model SC401 Dual Cylinder Scale can accommodate any gas cylinder not exceeding 12" diameter and 150 lbs. net weight.

## SPECIFICATIONS

Accuracy:	±1% F.S.
Resolution:	1 lb.
Scale Readability:	1/2 lb.
Scale Capacity:	300 lbs.
Safe Overload Capacity:	400 lbs.

## FEATURES

1. Simultaneously weighs two cylinders independently and displays the net weight on separate indicators.
2. Adjustable cross bar and chains adapt to different size cylinders.
3. All scales are assembled, tested, and calibrated at the factory. Simple assembly on the job site is all that is required.
4. Easy to read 5" scale length with 150 graduations that allow for 1/2 lb. readability.

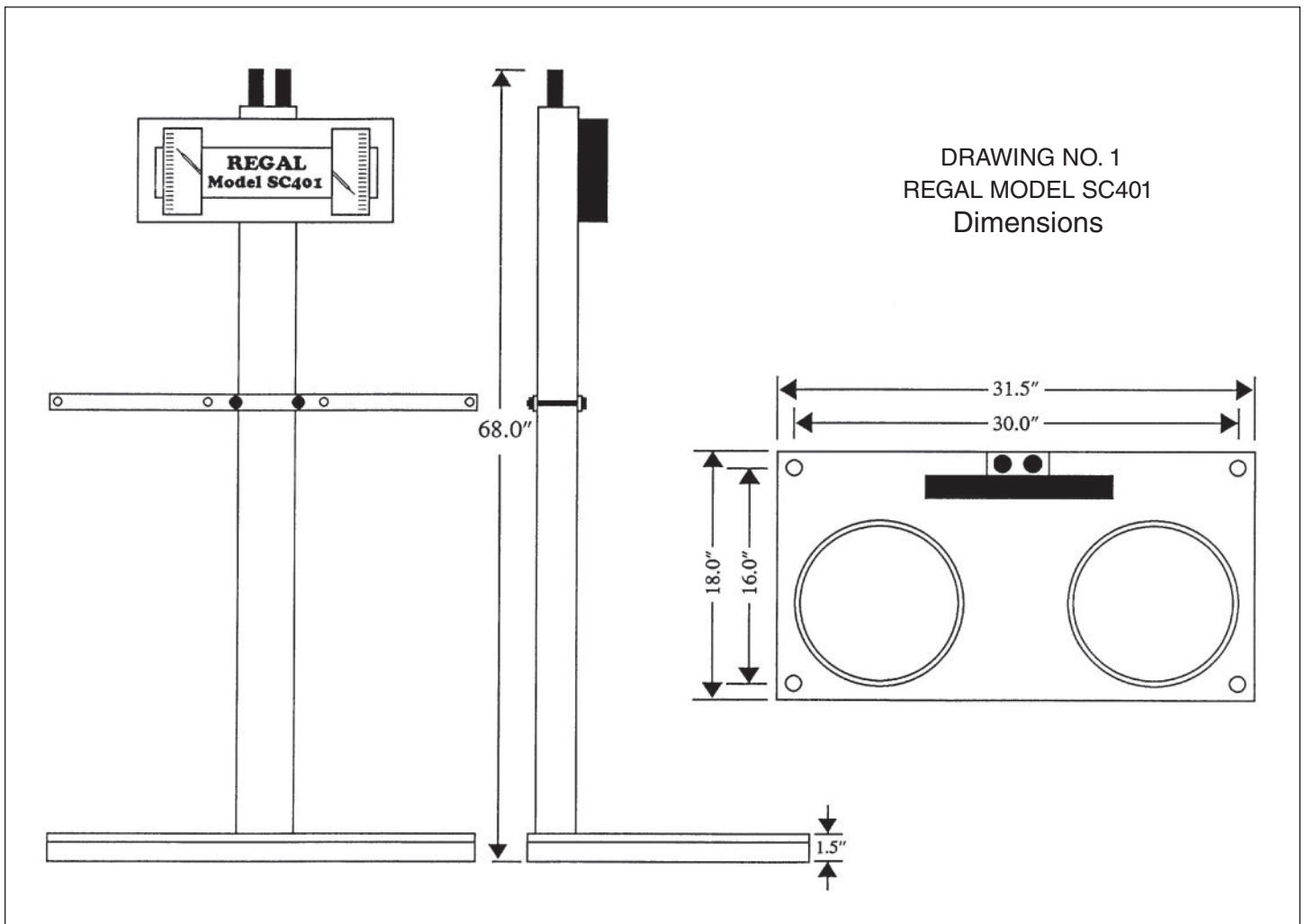

# PARTS LIST

Item	Quantity	Part No.	Description
1	2	SC601	Zero Knob
2	1	SC602	Overlay
3	1	SC603	Backplate
4	1	SC604	Support Arm Strap
5	1	SC605	Support Arm
6	2	SC606	5/16-18 x 4 Hex Bolt
7	2	SC607	5/16 Hex Nut
8	2	SC608	5/16 Lock Washer
9	2	SC609	Cylinder Chain
10	1	SC610	Post
11	1	SC611	Post Clamp
12	12	SC612	10B x 5/8 Self Tap
13	6	SC613	Pivot Screw
14	2	SC614	Disc
15	1	SC615	Deck
16	2	SC616	Stop "E" Ring
17	2	SC617	Steelyard Stop
18	2	SC618	Steelyard
19	2	SC619	Adjusting Nut
20	2	SC620	Jam Nut
21	2	SC621	Clevis
22	2	SC622	Clevis Bushing
23	2	SC623	Link
24	2	SC624	Tension Spring
25	2	SC625	Zero Adjustment Link
26	2	SC626	Socket Set Screw
27	1	SC627	Post Cap
28	2	SC628	Link "E" Ring
29	2	SC629	Dial Scale
30	2	SC630	Pointer Crank Axle
31	2	SC631	Pointer "E" Ring
32	2	SC632	Pointer
33	2	SC633	Axle Bushing
34	2	SC634	Pointer Axle
35	2	SC635	Lock Nut
36	6	SC636	Disc Washer
37	6	SC637	Perimeter Flexure
38	6	SC638	Perimeter Clamp
39	2	SC639	Center Clamp
40	2	SC640	Center Flexure
41	4	SC641	Short Lever
42	2	SC642	Long Lever
43	4	SC643	6A-3/8 Self Tap Hex
44	8	SC644	10-24 x 3/8 Hex Head
45	12	SC645	10B-5/8 Self Tap Phillips
46	8	SC646	10A-3/8 Self Tap Hex
47	3	SC647	10-32 x 3 1/4 Bolt
48	2	SC648	5/16-18 x 2 1/2" Long Hex Head Bolt
49	2	SC649	5/16" Lock Washer

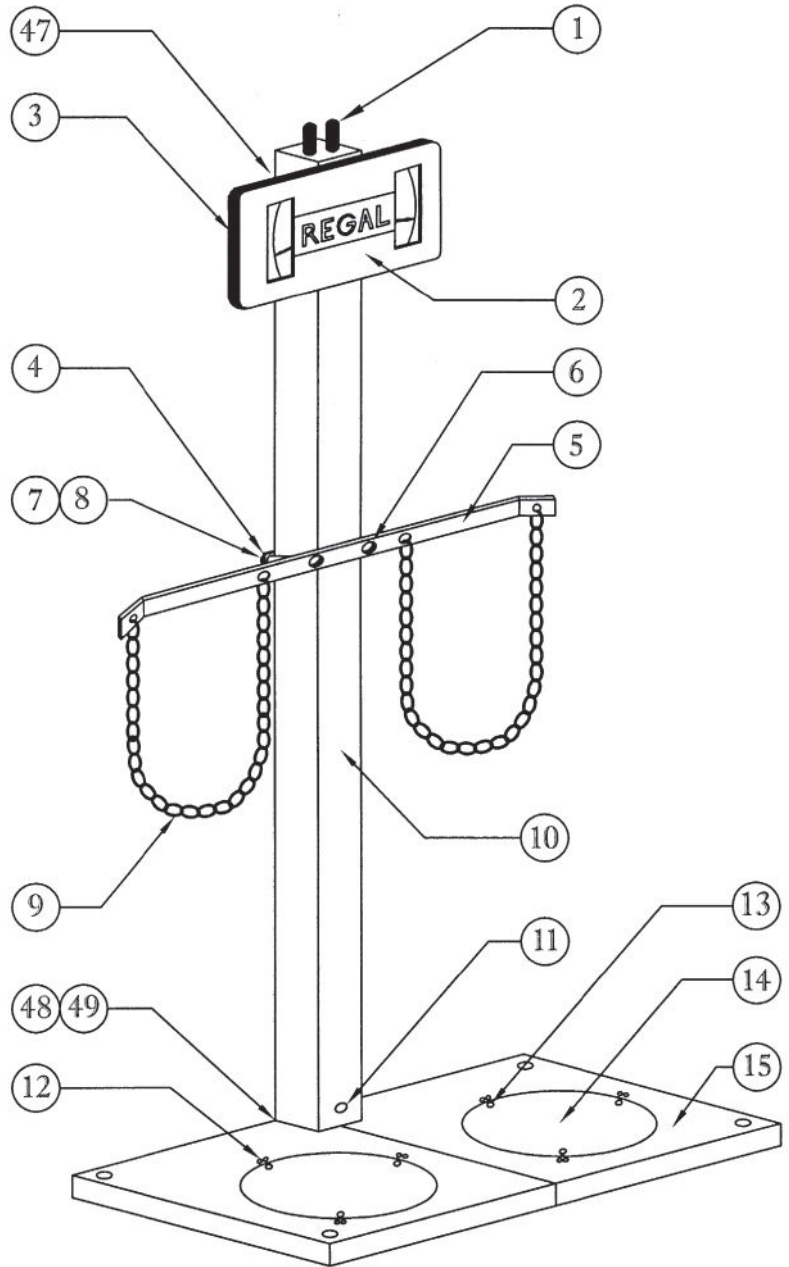

DRAWING NO. 2

## ASSEMBLY & INSTALLATION

1. **Upon receipt of the scale, immediately unpack and remove all scale parts and inspect for shipping damage. (Refer to Drawing No. 3 below).**
2. Place the POST ASSEMBLY on a flat surface (floor) with the INDICATOR face up. Screw the threaded EXTENSION RODS into the BRASS BOTTOM STOPS.

**CAUTION: DO NOT STAND THE POST VERTICAL AS DAMAGE TO THE STEELYARD CAN RESULT.**

3. Remove the plastic tie wraps from the SCALE DECK (base) and stand the SCALE DECK on its back skirt.
4. Slide the SCALE DECK and the POST ASSEMBLY together while using the EXTENSION RODS to guide the BRASS BOTTOM STOPS through the DECK and levers located under the DECK.
5. Screw the two 5/16" x 2 1/2" long bolts with lock washers through bottom of DECK and into bottom of POST assembly. Tighten securely.
6. Pull the EXTENSION RODS through the lever holes and insert the "E" RINGS into the snap groove of the BRASS BOTTOM STOPS.
7. Release the EXTENSION RODS and allow the BRASS BOTTOM STOPS to rest back into the lever holes under the DECK assembly.
8. Unscrew the EXTENSION RODS and stand the scale upright. It is IMPORTANT to note that the scale MUST be installed on a FLAT, LEVEL surface (floor). Anchor (bolt) the deck to the floor while being careful NOT to over-tighten the bolts. Doing so will distort the deck causing inaccuracy and possible damage.
9. Finally, mount the support arm to the Post and attach the cylinder safety chains.

## CHECKING CALIBRATION

The scales are fully calibrated before they are packaged and shipped from the factory. However, once installed, the following test should be performed to ensure proper operation.

1. Remove all weight from the platforms.
2. Using one foot, press separately on the circular disc located on each side of the platform while observing the pointer(s) to make sure they move smoothly without interference.
3. If any restriction of movement occurs, remove the front cover and correct the interference. Then replace the cover.
4. Separately turn each of the two Tare Knobs (located on top of the post) **counter-clockwise** until there is no tension remaining on the steelyard springs. The knob(s) will turn freely at this time.
5. Now, turn each Tare Knob **clockwise** and the pointer will start to drop. Continue turning the knob slowly until the pointer drops just below zero (approx. 1/8 inch) on the dial scale.
6. After completing these steps for both sides, the scale is ready for OPERATION.

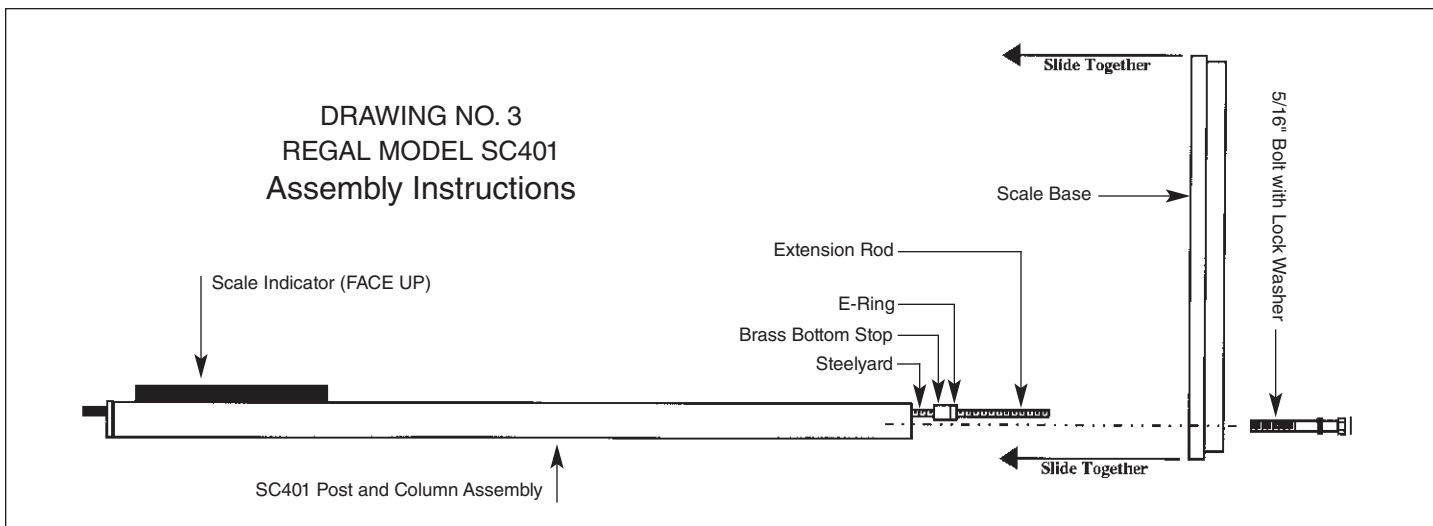

## OPERATION

1. Place a full chlorine cylinder in the center of the circular disc on each side of the platform and connect the safety chains to hold the cylinder in place.
2. Mount the REGAL Gas Feed Regulator to the cylinder and make the required connections.
3. Use the tare weight adjusting knobs to set each scale pointer to the net weight (150 lbs. for Chlorine) of each cylinder. The scale is now ready to monitor the weight of chemical remaining as it is being drawn from each cylinder.

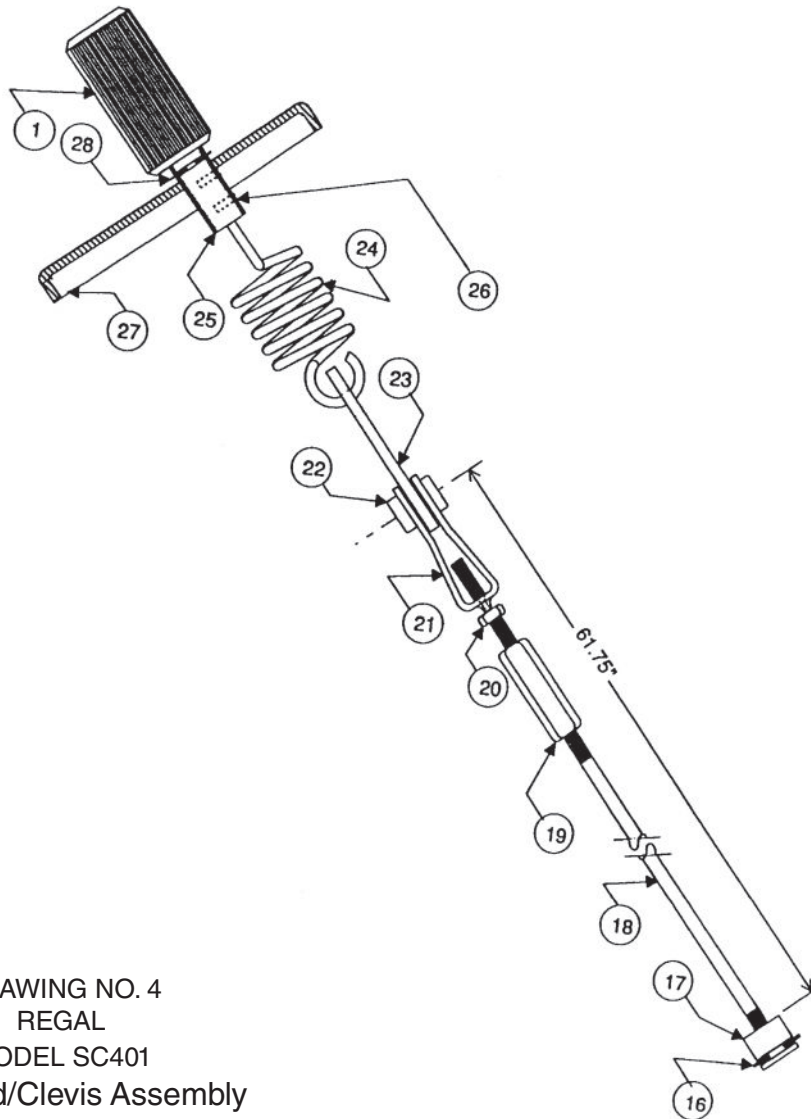

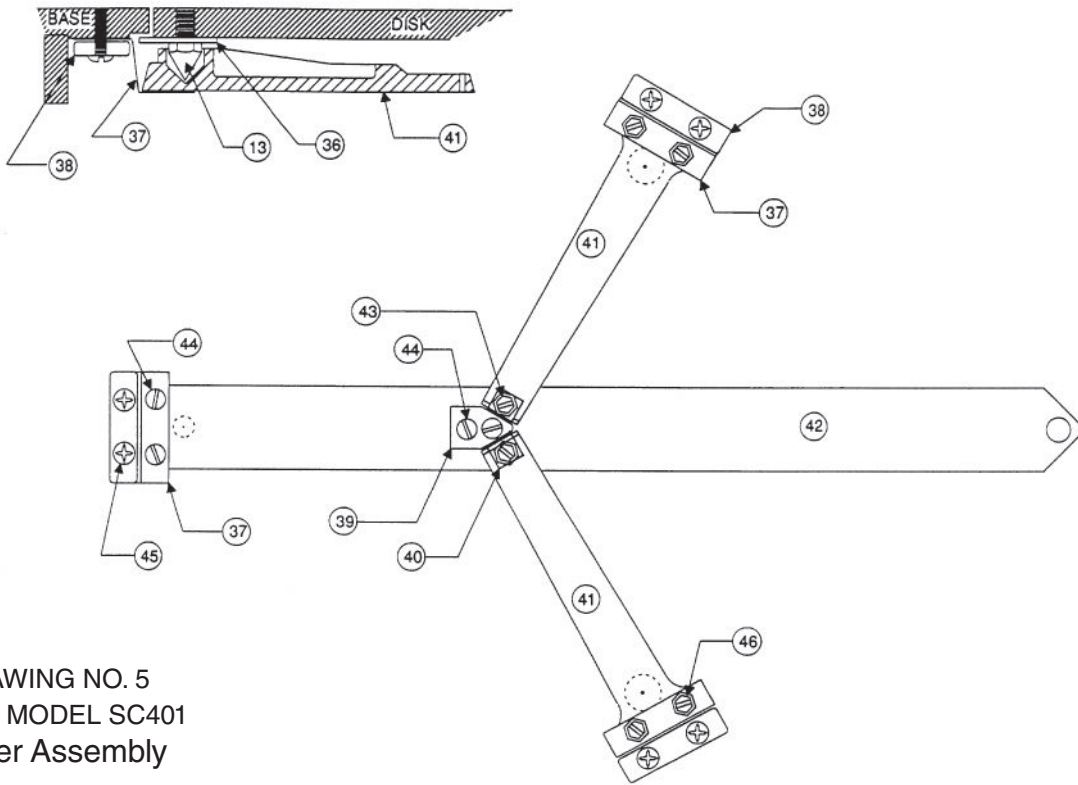

DRAWING NO. 5  
 REGAL MODEL SC401  
 Spider Assembly

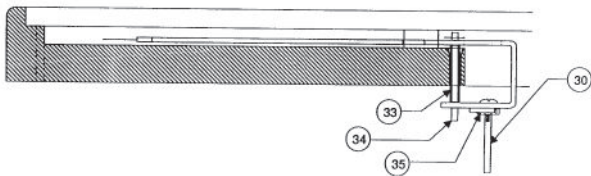
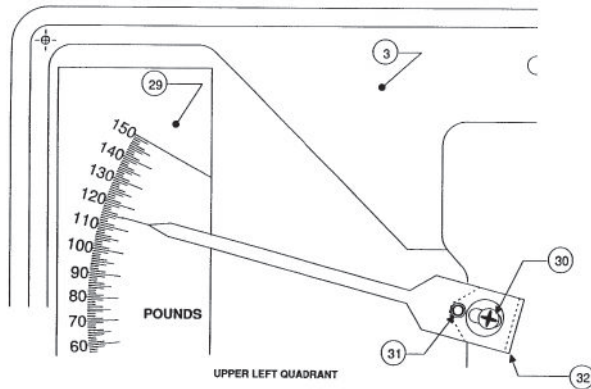

DRAWING NO. 6  
 REGAL  
 MODEL SC401  
 Pointer Assembly



1044 SE Dixie Cutoff Road, Stuart, Florida 34994 USA

Phone: (772) 288-4854 • Fax: (772) 287-3238 • [www.regalchlorinators.com](http://www.regalchlorinators.com) • Email: [regal@regalchlorinators.com](mailto:regal@regalchlorinators.com)

**REGAL GAS CHLORINATORS: PURE WATER. PURE AND SIMPLE.**