

## TECHNICAL MANUAL

INSTALLATION MANUAL FOR EXPORT UNITS  
SERVICE MANUAL FOR DOMESTIC UNITS

FOR JACKSON MODELS:

R24

R30





<b>REVISION</b>	<b>REVISION DATE</b>	<b>MADE BY</b>	<b>APPLICABLE ECN</b>	<b>DETAILS</b>
E	03-01-04	MAW	6431	CHANGED 5/8" TO 1/2" SCREW. CONVERTED OVER TO THE NEW LAYOUT.
F	12-05-05	CBW	7075, 7290, 7324	ADDED WORK INSTRUCTIONS AND NEW SERVICE KITS, ADDED NEW STIFFENER NUMBER
G	07-31-06	MAW	7618, 7657 7751	Converted to center layout. Replaced relay with contactor. Updated vacuum breaker plumbing assemblies. Updated schematic.



## GLASSWASHER SERIES

R24 = 24" Glasswasher  
R30 = 30" Glasswasher

Model: \_\_\_\_\_

Serial No.: \_\_\_\_\_

Installation Date: \_\_\_\_\_

Service Rep. Name: \_\_\_\_\_

Phone No.: \_\_\_\_\_

---

## TABLE OF CONTENTS

---

<b><u>SECTION</u></b>	<b><u>DESCRIPTION</u></b>	<b><u>PAGE</u></b>
I.	<b>GENERAL</b>	
	Specifications	2
	Dimensions	3
II.	<b>INSTRUCTIONS SECTION</b>	
	Installation Instructions	5
	Electrical Connections	6
	Detergent Control	7
	Chemical Dispensing	8
	Operating Instructions	9
	Sequence of Operation	10
III.	<b>PREVENTATIVE MAINTENANCE</b>	12
IV.	<b>TROUBLESHOOTING SECTION</b>	14
V.	<b>MAINTENANCE INSTRUCTIONS</b>	
	Replacing the Rack Wrap	18
	Replacing the Chemical Feeder Pump Motor	20
	Wash Tank Heater Replacement	23
	Thermostat Replacement	26
	Wash Motor Replacement	29
VI.	<b>PARTS SECTION</b>	
	Control Box Assembly R24	33
	Electrical Box Cover Assembly R24	34
	Control Box Assembly R30	35
	Electrical Box Cover Assembly R30	36
	Chemical Feeder Pump Assembly	37
	Drive Motor Assembly	38
	Drive Assembly Retro Fit Kit No. 1	39
	Drive Assembly Retro Fit Kit No. 2	40
	Drive Gear Assembly	41
	Drive Motor Assembly (Original Style)	42
	Incoming Plumbing Assembly	43
	Injection Manifold	44
	Vacuum Breaker Assembly/Wash Fill Components	45
	Wash Tank Assembly	46
	Rinse Sump Assembly/ Wash & Rinse Arms	47
	Wash Motor Replacement Kits	48
	Operation Instruction Decal	49
	Wash & Rinse Manifolds	50
	Rack Wrap Replacement Kit/Front Shield Weldment	51
	Drain Board Assemblies	52
	Door Assembly/Switches	53
	Curtain/Curtain Rod	54
	Miscellaneous Parts	55
VII.	<b>ELECTRICAL DIAGRAM</b>	
	R24 & R30 208-230 Volt, 60 Hertz, Single Phase	57

---

---

# **SECTION 1: SPECIFICATION INFORMATION**

## SECTION 1: SPECIFICATION INFORMATION

### SPECIFICATIONS

#### R24

#### OPERATING CAPACITY (RACKS/HOUR)

GLASSES PER HOUR 1200

#### OPERATING CYCLE (SECONDS)

TOTAL CYCLE TIME 120

#### TANK CAPACITY (GALLONS)

3.0

#### WASH PUMP CAPACITY

WASH PUMP 55 GPM

#### TEMPERATURES

WASH---°F (MINIMUM) 130

RINSE---°F (MINIMUM) 75

#### ELECTRICAL REQUIREMENTS

WASH PUMP MOTOR HORSEPOWER 3/4

**NOTE: Typical Electrical Circuit is based upon (1) 125% of the full amperage load of the machine and (2) typical fixed-trip circuit breaker sizes as listed in the NEC 2002 Edition. Local codes may require more stringent protection than what is displayed here. Always verify with your electrical service contractor that your circuit protection is adequate and meets all applicable national and local codes. These numbers are provided in this manual simply for reference and may change without notice at any given time.**

<u>VOLTS</u>	<u>PH</u>	<u>HZ</u>	<u>RINSE HEATER RATINGS</u>	<u>TOTAL AMPS</u>	<u>TYPICAL ELECTRICAL CIRCUIT</u>
208	1	60	220V/3KW	20	25 AMP
230	1	60	220V/3KW	18	25 AMP

#### WATER REQUIREMENTS

INLET TEMPERATURE 130°F

GALLONS PER HOUR 10.0

WATER LINE SIZE NPT (Minimum) 1/2"

DRAIN LINE SIZE NPT (Minimum) 2"

FLOW PRESSURE P.S.I. 20 ± 5

MINIMUM CHLORINE REQUIRED (PPM) 50

MINIMUM IODIPHOR REQUIRED (PPM) 12.5

**NOTE: Always refer to the machine data plate for specific electrical and water requirements. The material provided on this page is for reference only and may be subject to change without notice.**

#### R30

#### OPERATING CAPACITY (RACKS/HOUR)

GLASSES PER HOUR" 1800

#### OPERATING CYCLE (SECONDS)

TOTAL CYCLE TIME 120

#### TANK CAPACITY (GALLONS)

4.14

#### WASH PUMP CAPACITY

WASH PUMP 55 GPM

#### TEMPERATURES

WASH---°F (MINIMUM) 130

RINSE---°F (MINIMUM) 75

#### ELECTRICAL REQUIREMENTS

WASH PUMP MOTOR HORSEPOWER 3/4

**NOTE: Typical Electrical Circuit is based upon (1) 125% of the full amperage load of the machine and (2) typical fixed-trip circuit breaker sizes as listed in the NEC 2002 Edition. Local codes may require more stringent protection than what is displayed here. Always verify with your electrical service contractor that your circuit protection is adequate and meets all applicable national and local codes. These numbers are provided in this manual simply for reference and may change without notice at any given time.**

<u>VOLTS</u>	<u>PH</u>	<u>HZ</u>	<u>RINSE HEATER RATINGS</u>	<u>TOTAL AMPS</u>	<u>TYPICAL ELECTRICAL CIRCUIT</u>
208	1	60	220V/3KW	20	25 AMP
230	1	60	220V/3KW	18	25 AMP

#### WATER REQUIREMENTS

INLET TEMPERATURE 130°F

GALLONS PER HOUR 10.0

WATER LINE SIZE NPT (Minimum) 1/2"

DRAIN LINE SIZE NPT (Minimum) 2"

FLOW PRESSURE P.S.I. 20 ± 5

MINIMUM CHLORINE REQUIRED (PPM) 50

MINIMUM IODIPHOR REQUIRED (PPM) 12.5

**NOTE: Always refer to the machine data plate for specific electrical and water requirements. The material provided on this page is for reference only and may be subject to change without notice.**

# SECTION 1: SPECIFICATION INFORMATION

## DIMENSIONS

**LEGEND:**

**A - WATER INLET 1/2" IPS (COLD)**

**B - WATER INLET 1/2" IPS (HOT)**

**C - DRAIN 2" NOMINAL**

**D - STANDARD WALL CLEARANCE: 2"**

LETTER	R24	R30
E	26-1/4"	30-5/16"
F	25-1/4"	30-1/2"
G	14-3/4"	16-1/4"
H	7-1/2"	8-5/8"
I	18-11/16"	23-11/16"

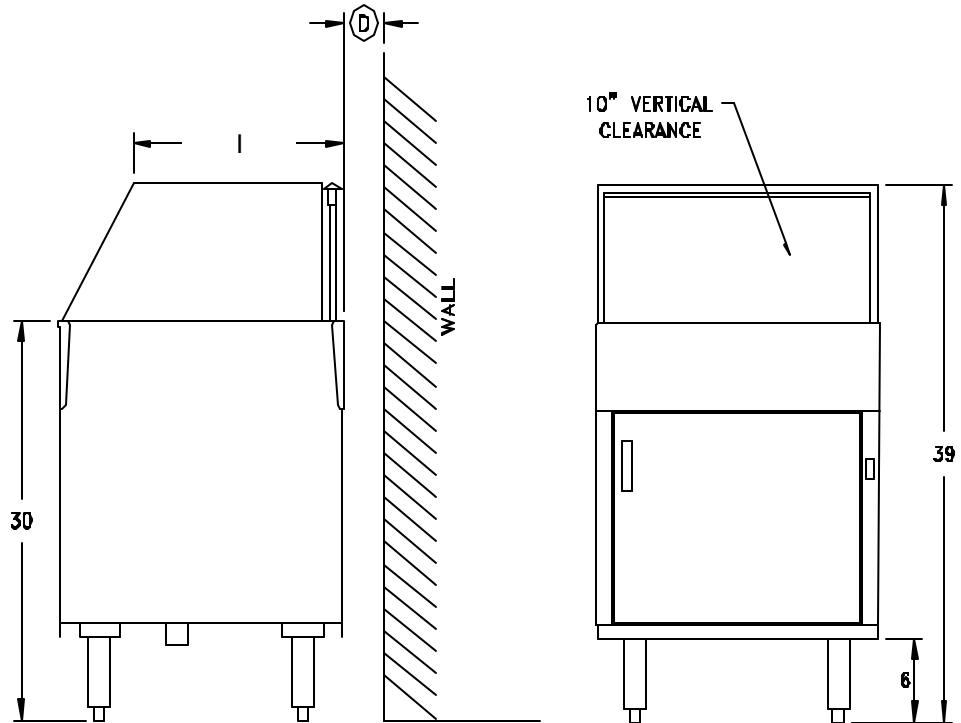
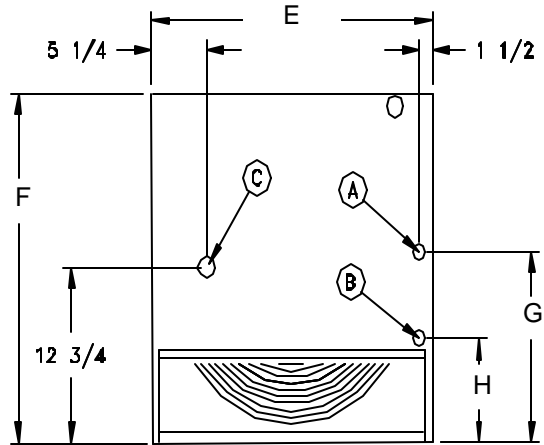



---

**SECTION 2:  
INSTALLATION/OPERATION  
INSTRUCTIONS**

## SECTION 2: INSTALLATION/OPERATION INSTRUCTIONS

### INSTALLATION INSTRUCTIONS

**VISUAL INSPECTION:** Before installing the unit, check the container and machine for damage. A damaged container is an indicator that there may be some damage to the machine. If there is damage to both the container and machine, do not throw away the container. The dishmachine has been inspected and packed at the factory and is expected to arrive to you in new, undamaged condition. However, rough handling by carriers or others may result in there being damage to the unit while in transit. If such a situation occurs, do not return the unit to Jackson; instead, contact the carrier and ask them to send a representative to the site to inspect the damage to the unit and to complete an inspection report. You must contact the carrier within 48 hours of receiving the machine. Also, contact the dealer through which you purchased the unit.



Packaged unit should be visually inspected for damage.

**UNPACKING THE DISHMACHINE:** Once the machine has been removed from the container, ensure that there are no missing parts from the machine. This may not be obvious at first. If it is discovered that an item is missing, contact Jackson immediately to have the missing item shipped to you.



Use a pry bar and mallet to remove the hold-down blocks.



Lift the box off of the unit.



Remove any protective plastic prior to installation.

**LEVEL THE DISHMACHINE:** The dishmachine is designed to operate while being level. This is important to prevent any damage to the machine during operation and to ensure the best results when washing ware. The unit comes with adjustable bullet feet, which can be turned using a pair of channel locks or by hand if the unit can be raised safely. Ensure that the unit is level from side to side and from front to back before making any connections.

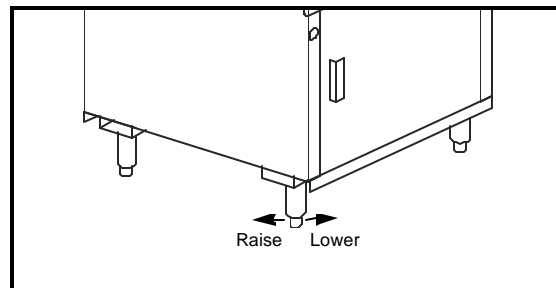

## SECTION 2: INSTALLATION/OPERATION INSTRUCTIONS

### ELECTRICAL CONNECTIONS

**PLUMBING THE DISHMACHINE:** All plumbing connections must comply with all applicable local, state, and national plumbing codes. The plumber is responsible for ensuring that the incoming water line is thoroughly flushed prior to connecting it to any component of the dishmachine. It is necessary to remove all foreign debris from the water line that may potentially get trapped in the valves or cause an obstruction. Any valves that are fouled as a result of foreign matter left in the water line, and any expenses resulting from this fouling, are not the responsibility of the manufacturer.

**CONNECTING THE DRAIN LINE:** The R24/R30 glasswashers have a gravity drain (2" NPT connection). All piping from the machine to the drain must be a minimum 2" NPT and shall not be reduced. There must also be an air gap between the machine drain line and the floor sink or drain. If a grease trap is required by code, it should have a flow capacity of 5 gallons per minute.

**WATER SUPPLY CONNECTION:** Ensure that you have read the section entitled "PLUMBING THE DISHMACHINE" above before proceeding. Cold water supply must be a minimum of 70°F with a capacity of 180 gallons per hour at 8-12 PSI flow to the glasswasher. Hot water supply must be a minimum of 130°F with a capacity of 10 gallons per hour at 20 ±5 PSI flow pressure. Incoming hot and cold water service connection (supplied by customer) must be a 1/2" pipe size minimum with shut off valve. Install the water supply line (1/2" pipe size minimum) to the dishmachine using copper pipe. It is recommended that a water shut-off valve be installed in the water line between the main supply and the machine to allow access for service.

In areas where the water pressure fluctuates or is greater than the recommended pressure, it is suggested that a water pressure regulator be installed.

Do not confuse static pressure with flow pressure. Static pressure is the line pressure in a "no flow" condition (all valves and services are closed). Flow pressure is the pressure in the fill line when the fill valve is opened during the cycle.

It is also recommended that shock absorbers (not supplied with the R24 & R30 units) be installed in the incoming water lines. This prevents line hammer (hydraulic shock), induced by the solenoid valves as they operate, from causing damage to the equipment.

**PLUMBING CHECK:** Slowly turn on the water supply to the machine after the incoming fill line and the drain line have been installed. Check for any leaks and repair as required. All leaks must be repaired prior to placing the machine in operation.

**ELECTRICAL POWER CONNECTION:** Electrical and grounding connections must comply with the applicable portions of the National Electrical Code ANSI/NFPA 70 (latest edi-

tion) and/or other electrical codes. Disconnect electrical power supply and place a tag at the disconnect switch to indicate that you are working on the circuit.

The dishmachine data plate is located on the right side of the door. Refer to the data plate for machine operating requirements, machine voltage, total amperage load and serial number.

To install the incoming power lines, remove the electrical box cover. This will require taking a phillipshead screwdriver and removing the two (2) screws at the bottom corners and lift up and off. Let the cover rest against the plumbing assembly. Install conduit from the underside of machine to hole in rear of electrical box below terminal block and ground lug. Install the service wires (L1 & L2) to the appropriate terminals as they are marked on the terminal block. Install the grounding wire into the lug provided. Tighten the connections. It is recommended that "DE-OX" or another similar anti-oxidation agent be used on all power connections.

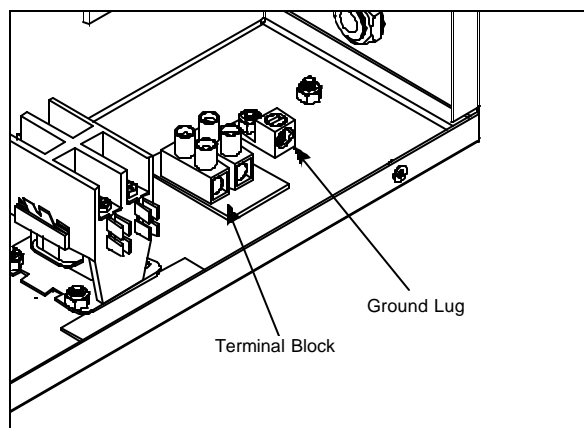

**VOLTAGE CHECK:** Ensure that the power switch is in the OFF position and apply power to the dishmachine. Check the incoming power at the terminal block and ensure it corresponds to the voltage listed on the data plate. If not, contact a qualified service agency to examine the problem. Do not run the dishmachine if the voltage is too high or too low. Shut off the service breaker and mark it as being for the dishmachine. Advise all proper personnel of any problems and of the location of the service breaker. Replace the electrical box cover and tighten down the screws.

---

## SECTION 2: INSTALLATION/OPERATION INSTRUCTIONS

---

### DETERGENT CONTROL

Detergent usage and water hardness are two factors that contribute greatly to how efficiently your dishmachine will operate. Using detergent in the proper amount can become, in time, a source of substantial savings. A qualified water treatment specialist can tell you what is needed for maximum efficiency from your detergent, but you should still know some basics so you'll understand what they are talking about.

First, you must understand that hard water greatly effects the performance of the dishmachine. Water hardness is the amount of dissolved calcium and magnesium in the water supply. The more dissolved solids in the water, the greater the water hardness. Hard water works against detergent, thereby causing the amount of detergent required for washing to increase. As you use more detergent, your costs for operating the dishmachine will increase and the results will decrease. The solids in hard water also may build-up as a scale on wash and rinse heaters, decreasing their ability to heat water. Water temperature is important in removing soil and sanitizing dishes. If the water cannot get hot enough, your results may not be satisfactory. This is why Jackson recommends that if you have installed the machine in an area with hard water, that you also install some type of water treatment equipment to help remove the dissolved solids from the water before it gets to the dishmachine.

Second, hard water may have you adding drying agents to your operating cycle to prevent spotting, when the real problem is deposited solids on your ware. As the water evaporates off of the ware, the solids will be left behind to form the spotting and no amount of drying agent will prevent this. Again, using treated water will undoubtedly reduce the occurrences of this problem.

Third, treated water may not be suitable for use in other areas of your operation. For instance, coffee made with soft water may have an acid or bitter flavor. It may only be feasible to install a small treatment unit for the water going into the dishmachine itself. Discuss this option with your qualified water treatment specialist.

Even after the water hardness problems have been solved, there still must be proper training of dishmachine operators in how much detergent is to be used per cycle. Talk with your water treatment specialist and detergent vendor and come up with a complete training program for operators. Using too much detergent has as detrimental effects as using too little. The proper amount of detergent must be used for job. It is important to remember that certain menu items may require extra detergent by their nature and personnel need to be made aware of this. Experience in using the dishmachine under a variety of conditions, along with good training in the operation of the machine, can go a long way in ensuring your dishmachine operates as efficiently as possible.

Certain dishmachine models require that chemicals be provided for proper operation and sanitization. Some models even require the installation of third-party chemical feeders to introduce those chemicals to the machine. Jackson does not recommend or endorse any brand name of chemicals or chemical dispensing equipment. Contact your local chemical distributor for questions concerning these subjects.

Some dishmachines come equipped with integral solid detergent dispensers. These dispensers are designed to accommodate detergents in a certain sized container. If you have such a unit, remember to explain this to your chemical distributor upon first contacting them.

As explained before, water temperature is an important factor in ensuring that your dishmachine functions properly. The data plate located on each unit details what the minimum temperatures must be for either the incoming water supply, the wash tank and the rinse tank, depending on what model of dishmachine you have installed. These temperatures may also be followed by temperatures that Jackson recommends to ensure the highest performance from you dishmachine. However, if the minimum requirements are not met, the chances are your dishes will not be clean or sanitized. Remember, a dish can look clean, but it may not be sanitized. Instruct your dishmachine operators to observe the required temperatures and to report when they fall below the minimum allowed. A loss of temperature can indicate a much larger problem such as a failed heater or it could also indicate that the hot water heater for your operation is not up to capacity and a larger one may need to be installed.

There are several factors to consider when installing your dishmachine to ensure that you get the best possible results from it and that it operates at peak efficiency for many years. Discuss your concerns with your local chemical distributor and water treatment specialist before there is a problem.

---

## SECTION 2: INSTALLATION/OPERATION INSTRUCTIONS

### CHEMICAL DISPENSING EQUIPMENT

#### TO PREPARE PUMPS FOR OPERATION

The R24 & R30 are supplied with detergent, rinse additive and sanitizer dispensing chemical feeder pumps. Locate the open ends of the chemical tubes with the tube stiffeners and place each one in the appropriate container.

- A. **Red** Tubing = **Detergent**
- B. **Blue** Tubing = **Rinse Aid**
- C. **White** Tubing = **Sanitizer**

#### PRIMING CHEMICAL FEEDER PUMPS

Chemical feeder pumps need priming when the machine is first installed, when chemicals are replenished, or if for some reason the chemical lines have been removed and air is allowed to enter.

1. Verify that the proper chemical tube stiffener inlet is in the proper container.
2. Use the toggle switches on the right side of control box to prime each pump.
3. To prime the pumps, hold the switch in the momentary position until chemical can be observed exiting the pump.
4. Detergent is dispensed as required during the wash tank fill. The amount of detergent may need to be increased or decreased depending on water quality and type of detergent. It is adjusted by turning the potentiometer on the speed control board clockwise to increase, counter-clockwise to decrease.
5. Rinse additive is dispensed proportionally into the final rinse water line. The amount of rinse aid may need to be adjusted depending on water hardness and results. It is adjusted by turning the potentiometer on the speed control board clockwise to increase, counter-clockwise to decrease.
6. Sanitizer either chlorine or iodine is dispensed proportionally into the final rinse water line. The amount of sanitizer may need to be adjusted depending on concentration and the type of sanitizer used. It is adjusted by turning the potentiometer on the speed control board clockwise to increase, counter-clockwise to decrease.
7. **Warning:**  Some of the chemicals used in dishwashing may cause chemical burns if they come in contact with your skin. Wear appropriate protective gear when handling these chemicals. If you do come in contact with these chemicals flush the area with fresh water.

***This equipment is not recommend for use with deionized water or other aggressive fluids. Use of deionized water or other aggressive fluids will result in corrosion and failure of materials and components. Use of deionized water or other aggressive fluids will void the manufacturer's warranty.***

---

## SECTION 2: INSTALLATION/OPERATION INSTRUCTIONS

### OPERATING INSTRUCTIONS

#### TO FILL MACHINE WITH WATER:

1. Remove wash tank strainer and place overflow stopper into fitting at the bottom of the wash tank.
2. Open incoming water shut-off valves on cold and hot water lines.
3. Place the power switch to the "FILL" position, machine will automatically fill to the correct level.
4. Check water level, it should be near top of the overflow stopper.
5. Replace wash strainer.

#### TO RUN THE MACHINE:

1. After filling with water, turn the power switch to the "ON" position, the rack will automatically begin to rotate.
2. Place glasses on the rack.
3. When the glasses have completed the cycle, the paddle switch will be activated, turning off the water flow and conveyor rack.
4. Remove the clean glasses which are against the paddle switch.
5. The rack will begin to rotate again.

#### SHUTDOWN AND CLEANING OF THE MACHINE:

1. Ensure that all ware placed on the rack is able to complete the cycle and is cleaned prior to moving the power switch to the "OFF" position. Shut off the water supply to the unit.
2. Remove the drain boards, rack cylinder and rack. Clean and allow to dry before reinstalling into the machine.
3. Remove the sump and drain tank strainers. Clean completely and allow to dry before reinstalling into the machine.
4. Remove the stand pipe by grasping by the handle and removing from the drain tank. Clean and allow to dry before reinstalling into the machine.



**CAUTION: Water in the drain tank may be hot, allow the water to cool down and always remove the stand pipe through the use of the handle. Never place your hand in the water within the drain tank.**

5. Remove the curtains and wash using a mild soap and rinse with clear water. Allow to dry completely before reinstalling into the machine.
6. Remove the rack wrap from inside the tub. Clean and allow to dry completely before reinstalling into the machine.
7. Remove the wash and rinse arms. Inspect them for clogged or obstructed nozzles. Remove end caps and flush the inside of the wash and rinse arms with clean water. Reinstall end caps when completed.
8. Wipe out the inside of the tub, removing any and all debris.
9. Reinstall all components previously removed after they have been allowed to dry.
10. Remove, clean and reinstall upper (wash) and lower (drain) strainers.

---

## SECTION 2: INSTALLATION/OPERATION INSTRUCTIONS

### SEQUENCE OF OPERATION

#### REFER TO ELECTRICAL DIAGRAM FOR FUNCTION AND REFERENCE DESIGNATIONS.

1. All removable parts have been re-installed into machine and it is ready to operate.
2. Power switch (S1) is turned to the "Fill" position.
  - A. Hot water valve (HWV) is energized filling tank.
3. Tank is filled to operating level.
  - A. Top (FS1) and bottom (FS2) float switches close.
  - B. Wash tank fill relay (R2) is energized
  - C. Wash tank fill relay N.O. holding contact closes.
  - D. Wash tank fill relay N.O. contact closes energizing wash heater relay (R1).
  - E. Wash heater relay N.O. contacts close energizing the tank heater (H1).
  - F. Wash tank fill relay N.C. contact opens de-energizing hot water valve (HWV).
  - G. Detergent speed control is energized for peristaltic pump (DM) operation.

The machine is now ready for operation.

4. Power switch (S1) is turned to the "ON" position.
  - A. Conveyor drive motor (M1) is energized.
  - B. Wash pump motor (M2) is energized.
  - C. Cold water valve (CWV) is energized.
  - D. Power is supplied to speed control (SC) for the peri pump (RM, & SM) operation.

The glasswasher will continue to operate until either a glass trips the conveyor limit switch (S2) or the power switch (S1) is turned to the "OFF" position.

5. Glasses trip the conveyor limit switch (S2).
  - A. Conveyor drive motor (M1) is de-energized.
  - B. Wash pump motor (M2) is de-energized.
  - C. Cold water valve (CWV) is de-energized.
  - D. The unit will not run until the glass(es) are removed from the unload side of the unit.

Once this is done steps 4A, 4B & 4C will start and more glasses can be placed in the unit for washing.

The wash tank heater (H1) has two (2) methods of protection to prevent damage to the heater.

6. Bottom float switch (FS2) opens due to low water.
  - A. Wash tank fill relay (R2) is de-energized.
  - B. Wash tank fill relay N.O. holding contact opens.
  - C. Wash heater relay N.O. contacts open de-energizing the tank heater (H1).
7. High limit thermostat (TS1) opens due to sheath temperature exceeding preset limit.
  - A. Heat contactor (R1) is de-energized.
  - B. Wash heater relay N.O. contacts open de-energizing the tank heater (H1).
  - C. Proper water temperature will not be maintained for cleaning glasses.

---

## **SECTION 3: PREVENTATIVE MAINTENANCE**



---

## SECTION 3: PREVENTATIVE MAINTENANCE

### PREVENTATIVE MAINTENANCE

---

The dishmachines covered in this manual are designed to operate with a minimum of interaction with the operator. However, this does not mean that some items will not wear out in time. Jackson highly recommends that any maintenance and repairs not specifically discussed in this manual should be performed by **QUALIFIED SERVICE PERSONNEL ONLY**. Performing maintenance on your dishmachine may void your warranty if it is still in effect, so if you have a question or concern, do not hesitate to contact Jackson.

There are many things that operators can do to prevent catastrophic damage to the dishmachine. One of the major causes of component failure has to do with prescraping procedures. A dishmachine is not a garbage disposal; any large pieces of material that are put into the machine shall remain in the machine until they are either broken up (after spreading out on your ware!) or physically removed. Strainers are installed to help catch debris, but they do no good if they are clogged. Have operators regularly inspect the pan strainers to ensure (1) that they are free of soil and debris and (2) they are laying flat in the tub.

When cleaning out strainers, do NOT beat them on waste cans. The strainers are made of metal and can be forgiving; but once severe damage is done, it is next to impossible for the strainer to work in the way it was designed to. Wipe out strainers with a rag and rinse under a faucet if necessary. For stubborn debris, a toothpick should be able to dislodge any obstructions from the perforations. Always ensure that strainers are placed back in the machine before operation and that they lay flat in the tub.

You may wish to also refer to the page entitled "Detergent Control" in order to learn more about how your water hardness will effect the performance of your machine. Hard water makes dishmachines work harder and decreases efficiency.

Again, it is important to remind operators that trying to perform corrective maintenance on the dishmachine could lead to larger problems or even cause harm to the operator. If a problem is discovered; secure the dishmachine using proper shut down procedures as listed in this manual and contact Jackson.

Some problems, however, may have nothing to do with the machine itself and no amount of preventative maintenance is going to help. A common problem has to do with temperatures being too low. Verify that the water temperatures coming to your dishmachine match the requirements listed on the machine data plate. There can be a variety of reasons why your water temperature could be too low and you should discuss it with Jackson to determine what can be done.

By following the operating and cleaning instructions in this manual, you should get the most efficient results from your machine. As a reminder, here are some steps to take to ensure that you are using the dishmachine the way it was designed to work:

1. Ensure that the water temperatures match those listed on the machine data plate.
2. Ensure that all strainers are in place before operating the machine.
3. Ensure that all wash and/or rinse arms are secure in the machine before operating.
4. Ensure that drains are closed/sealed before operating.
5. Remove as much soil from dishes by hand as possible before loading into racks.
6. Do not overfill racks.
7. Ensure that glasses are placed upside down in the rack.
8. Ensure that all chemicals being injected to machine have been verified as being at the correct concentrations.
9. Clean out the machine at the end of every workday as per the instructions in the manual.
10. Always contact Jackson whenever a serious problem arises.
11. Follow all safety procedures, whether listed in this manual or put forth by local, state or national codes/regulations.

---

## **SECTION 4: TROUBLESHOOTING**

---

## SECTION 4: TROUBLESHOOTING

### COMMON PROBLEMS



Inspection, testing and repair of electrical equipment should only be performed by a qualified service technician. Many of the tests require that the unit have power to it and live electrical components be exposed. **USE EXTREME CAUTION WHEN TESTING THE MACHINE.**

**Problem: Dish machine will not run, no voltage at wash relay terminals L1 and T1.**

1. Electrical power not installed to machine, service (main) power disconnect off. Ensure electrical wiring is run to machine and service (main) disconnect is on.
2. Branch circuit breaker tripped or fuse is blown. Reset or replace as required. Have an electrician check machine amp draw if problem keeps occurring.
3. Loose or broken connection to dish machine. Tighten, replace or repair as required.

**Problem: Machine cycles continuously.**

1. Limit switch actuator is loose or has fallen off. Reassemble/bend metal lever if necessary.
2. Faulty limit switch. Replace switch.

**Problem: Machine will not fill, other functions work.**

1. No water supply to machine. Ensure that water is hooked up properly to machine and that it is turned on.
2. Faulty Hot Water solenoid valve diaphragm or coil. Replace diaphragm and clean out valve. Measure continuity on coil, if there is none, replace the coil.
3. Faulty float switch. Ohm out the switch to ensure that upper and lower floats are working. If not, check float wiring to see if it is correct; if so, replace float.

**Problem: Machine fills continuously even with no power to the dish machine.**

1. Solenoid valve jammed/stuck in the open position. Check diaphragm and coil, replace as required.
2. Faulty float switch. Ohm out the switch to ensure that upper and lower floats are working. If not, check float wiring to see if it is correct; if so, replace float switch.

**Problem: Wash motor does not run, other functions work.**

1. Loose wire connection to limit switch or relay. Tighten wires.
2. Faulty pump motor. Replace pump motor.
3. Mechanical binding in the pump. If motor has correct incoming voltage, and the overload is tripping, repair or replace the pump.

**Problem: Wash motor does not run; other functions work.**

1. High or low voltage problem. Check voltage at motor and at power terminal block. Ensure it meets the electrical voltage specifications for the dish machine.
2. Faulty limit switch. Replace limit switch.

**Problem: Wash motor runs continuously.**

1. Wash relay welded closed. Turn machine off. If wash relay does not release, replace.

**Problem: Low water pressure.**

1. Water level is too low. Ensure that incoming water line pressure meets the requirements on dish machine data plate.
2. Wash arms clogged. Remove wash arms and clean.
3. Obstruction in pump housing. Disassemble and clear.
4. O-ring at wash tank drain cut or missing. Replace.

---

## SECTION 4: TROUBLESHOOTING

### COMMON PROBLEMS

**Problem: Low wash water pressure at wash arm spray nozzles.**

1. Pump impeller worn or broken. Replace pump.
2. Clogged jets in wash arms. Clean out wash arms.
3. Float stuck on float switch. Remove, clean and reinstall float switch.
4. Water level too low in the wash tank. Ensure that the incoming water line flow pressure meets the requirements on the dish-machine data plate.

**Problem: Machine keeps tripping service breaker.**

1. Power supply shorted to ground. Check for loose wires/burned connection. Replace or repair as required.
2. Pump impeller jammed. Disassembly and remove obstruction.
3. Wash pump motor faulty. Check motor voltage and amp draw.
4. Service breaker too small. Replace with correctly sized breaker.

**Problem: Machine will not hold water.**

1. Drain stopper not in place. Set drain stopper correctly in drain.
2. Drain fitting O-ring cut or missing. Replace O-ring.
3. Drain stopper bent or deformed. Replace.

**Problem: Sanitizer pump runs continuously.**

1. Shorted prime switch. If there is not line voltage between BLACK and ORANGE/BLACK wires to prime switch, replace.
2. Faulty speed control board. Check operation of board. If not working properly, replace.

**Problem: Sanitizer pump does not run during cycle, but runs when primed. Even when turntable is off.**

1. Loose or broken wire. Tighten connections to microswitch.
2. Faulty speed control board. Check operation of board. If not working properly, replace.
3. Faulty prime switch. Check continuity through each pole of switch. If it fails, replace the switch.

**Problem: Prime switch does not activate sanitizer pump.**

1. Faulty prime switch. With the prime switch in the prime position, check for voltage between BLACK and ORANGE/BLACK wires. If line voltage, replace switch.
2. Loose wire to prime switch. Tighten wire connection.

**Problem: Sanitizer pump doesn't run during cycle or through prime switch.**

1. Loose motor terminal wires. Tighten connections.

**Problem: Sanitizer pump doesn't run during cycle or through prime switch.**

1. Faulty sanitizer pump motor. If you read line voltage at the sanitizer motor terminals during the sanitizer feed cycle, replace the motor.
2. Faulty prime switch. Check the continuity through each pole of the switch. If faulty, replace the switch.

**Problem: Detergent not feeding, rinse aid feeds okay.**

1. Faulty speed control board. Check operation of board. If not working properly, replace.
2. Defective hose or squeeze tube. Replace hose or squeeze tube as needed.
3. Machine not in fill mode. Normal operation.

---

## SECTION 4: TROUBLESHOOTING

### COMMON PROBLEMS

**Problem: Rinse aid pump not feeding, detergent feeds okay.**

1. Faulty speed control board. Check operation of board. If not working properly, replace.
2. Defective hose or squeeze tube. Replace hose or squeeze tube as needed.

**Problem: Wash heater does not work. (Note: push wash heater contactor bar down and take amperage reading. Amps should be correct as stated on the dish machine data plate).**

1. If no amp draw, check wash heater for continuity. If open or shorted, replace the heater. If closed, replace the heater contactor.
2. Wash heater relay will not energize (no voltage at contactor coil). Check for continuity at wash thermostat. If open, replace.
3. Low voltage problem. Check incoming voltage to ensure it as what the data plate calls for.

---

# **SECTION 5: SERVICE PROCEDURES**

---

## SECTION 5: SERVICE PROCEDURES

### REPLACING THE RACK WRAP

Jackson glasswasher machines come equipped with rack wraps and rollers used to guide the ware through the machine and to keep the rack mobile. Occasionally, some of these parts may need replacing to maintain optimum performance.

Jackson offers all of the repair parts necessary for performing this task.

The instructions provided here are for maintenance personnel only. Unauthorized persons should not attempt any of the steps contained in these instructions.

**Warning: many of the instructions and steps within this document require the use of tools. Only authorized personnel should ever perform any maintenance procedure on the dishmachine!**

#### PREPARATION

1. Power must be secured to the unit at the service breaker. Tag or lock out the service breaker to prevent accidental or unauthorized energizing of the machine.

2. Ensure that incoming water to the machine is secured either by use of a shut-off valve or disconnecting the incoming water line.

#### TOOLS REQUIRED

The following tools will be needed to perform this maintenance evolution:

1. 3/8" Nutdriver
2. 7/16" Nutdriver

#### TIME REQUIRED

It is estimated that it will take (1) person ten minutes per motor to perform this task, not including all of the items indicated in the section entitled "PREPARATION".

#### IMPORTANT NOTES

1. Read these instructions thoroughly before attempting this maintenance task. Become familiar with the parts and what actions need to be taken. This will save time in the long run!

2. For instructions on replacing just the rollers, please go to step 9.

#### STEPS

1. Remove the drain boards, wash arms, rinse arms and the center rack.

2. Using the 3/8" nutdriver, remove the locknuts securing the rack wrap to the tub.



Remvoing the locknuts.

3. Once the locknuts are removed, grasp both sides of the rack wrap and pull them towards the center of the tub until the wrap comes off the mounting studs.



Remving the rack wrap.

4. Lift up slightly on the wrap to get it clear of the rear mounting bracket.

5. With the rack wrap removed, you may install your new one. Your complete assmeby kit should come with a rack wrap that already has the rollers mounted on them as well as some extra locknuts in case you lose the ones necessary for mounting the wrap to the tub.

---

## SECTION 5: SERVICE PROCEDURES

### REPLACING THE RACK WRAP (CONTINUED)

6. Install the new rack wrap and tighten down the mounting nuts using the 3/8" nutdriver. Ensure that the wrap lies securely in the rear mounting bracket.

7. Once the wrap is installed, verify that the rollers move freely.



Loosening the roller locknut.

8. If the rollers do not move freely, then use the 7/16" nutdriver to pack the locknut off slightly until the rollers spin. If the rollers do not spin, they will wear away and will have to eventually be replaced.

9. To replace any roller, use the 7/16" nutdriver to remove the mounting locknut. Pull the old roller out and discard, replacing with a new one. Then tighten down the locknut as far as possible without preventing the free rotation of the roller.

### AFTER MAINTENANCE ACTIONS

None.

### SPECIAL NOTES

Work performed on Jackson dishmachines by unauthorized or unqualified personnel may void the warranty. Before beginning this or any other maintenance evolution on a unit under warranty, you should contact a certified Jackson technician or Jackson Technical Service. You can find a list of qualified service agencies in the back of you unit's installation manual.

### SPECIAL PARTS

R24 Rack Wrap Replacement Kit:

R30 Rack Wrap Replacement Kit: 06401-003-12-25

Rack Roller: 05700-011-60-83



---

## SECTION 5: SERVICE PROCEDURES

### REPLACING THE CHEMICAL FEEDER PUMP MOTOR

---

Jackson glasswasher machines come equipped with chemical feeder pumps to ensure proper ware washing results. Occasionally, the motors operating these pumps may need replacing to maintain optimum performance.

Jackson offers all of the repair parts necessary for performing this task.

The instructions provided here are for maintenance personnel only. Unauthorized persons should not attempt any of the steps contained in these instructions.

**Warning: many of the instructions and steps within this document require the use of tools. Only authorized personnel should ever perform any maintenance procedure on the dishmachine!**

### PREPARATION

1. Power must be secured to the unit at the service breaker. Tag or lock out the service breaker to prevent accidental or unauthorized energizing of the machine.

2. Ensure that incoming water to the machine is secured either by use of a shut-off valve or disconnecting the incoming water line.

3. The unit must be drained completely with the drain stopper removed.

### TOOLS REQUIRED

The following tools will be needed to perform this maintenance evolution:

1. Phillipshead Screwdriver
2. Needlenose Pliers
3. Wire Cutters
4. Wire Strippers
5. Crimping Tool

### TIME REQUIRED

It is estimated that it will take (1) person thirty minutes per motor to perform this task, not including all of the items indicated in the section entitled "PREPARATION".

### IMPORTANT NOTES

1. Read these instructions thoroughly before attempting this maintenance task. Become familiar with the parts and what actions need to be taken. This will save time in the long run!

2. These instructions show steps on only (1) of the three motors. However, the steps are the same for each one.

### STEPS

1. Remove the front door.



Removing the screws for the electrical box cover.

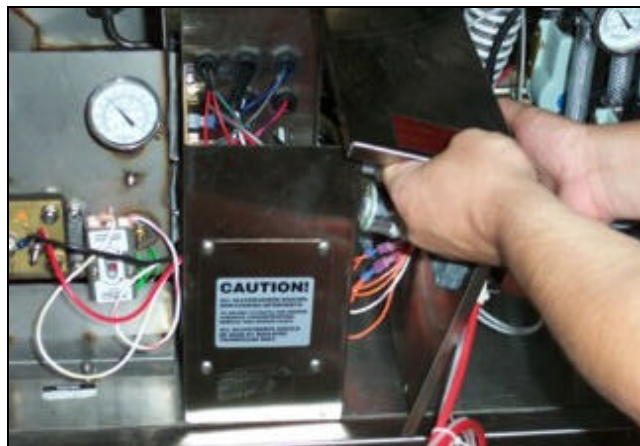

Removing the electrical box cover.

2. Remove the electrical box cover with the phillipshead screwdriver.

3. The cover must be laid down close to the control box because of the attached wires. Be careful not to yank out or damage any of the wires as you move the cover.

4. Determine which motor you wish to replace, or which one you wish to start with. Trace the wires leading from the motor to its corresponding prime switch. Trace the other wire from the motor to determine where it is connected.

5. With the needlenose pliers, remove the motor wire from the prime switch, being careful not to damage the prime switch in the process. (If the prime switch is damaged, it will need to be

---

## SECTION 5: SERVICE PROCEDURES

### REPLACING THE CHEMICAL FEEDER PUMP MOTOR (CONTINUED)

---

replaced. Refer to the parts section of the technical manual for information regarding part numbers for ordering new prime switches.)

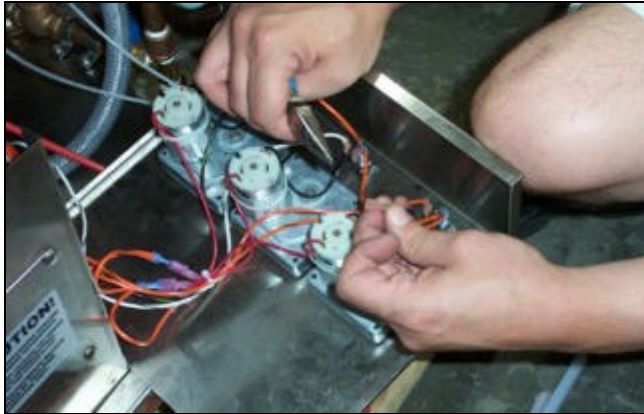

Removing the priming switch wire

6. Turn the cover over and using the phillipshead screwdriver, remove the cover to the pump requiring a motor change.

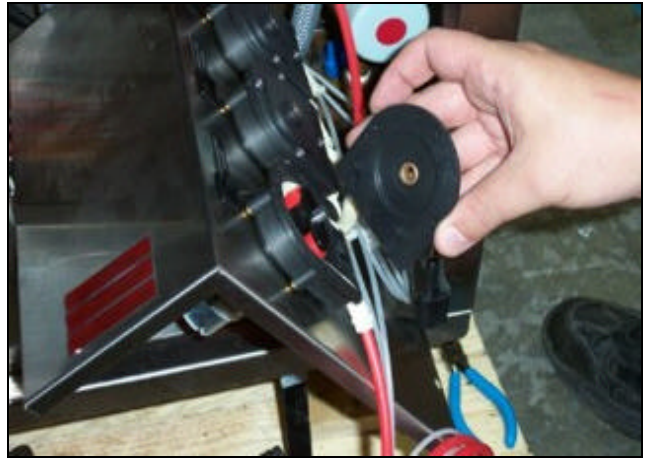

Removing the front cover.

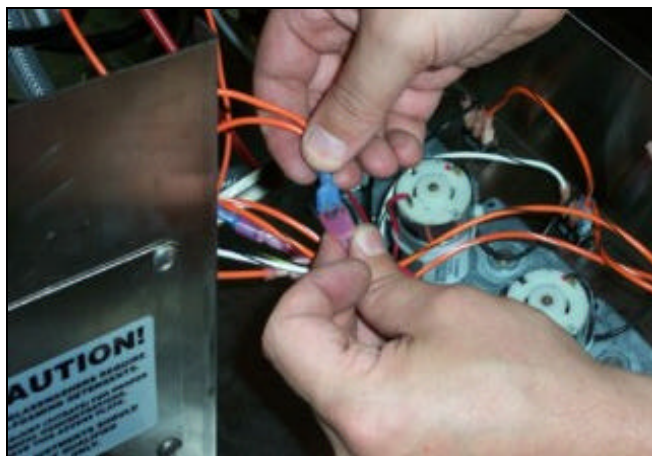

Unhooking motor power wire

7. With the cover removed, gently pull out the rubber tube from inside the pump.



Pulling the rubber tube out of the pump.

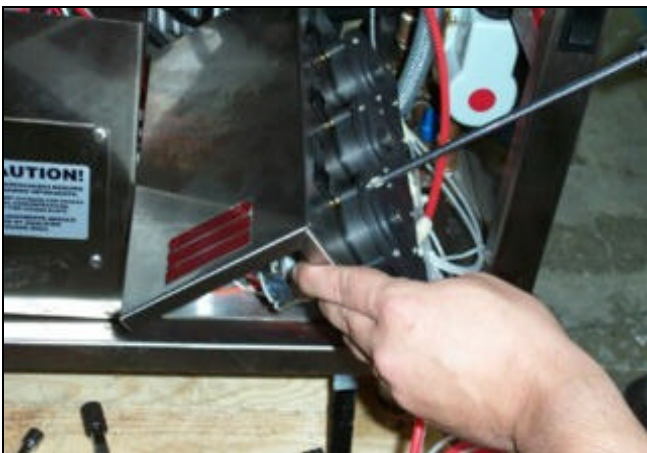

Removing the pump front cover screws.

8. Remove the roller by pulling it off of the shaft.

9. Using the phillipshead screwdriver, remove the four mounting screws for the motor.

10. Once the screws are removed, the motor should drop away.

11. Cut away any tie-wraps that are holding the power wires and remove the motor.

12. Take your new motor and attach new terminals to the wires as required.

13. Remount the motor to the pump.

---

## SECTION 5: SERVICE PROCEDURES

### REPLACING THE CHEMICAL FEEDER PUMP MOTOR (CONTINUED)

---

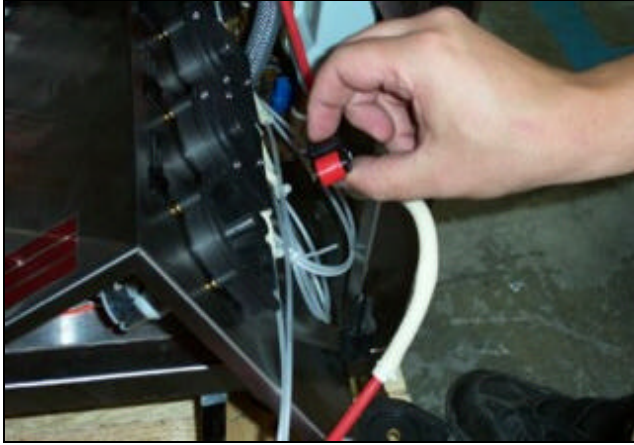

Removing the roller.

14. Place the roller and the rubber tube back in the pump casing. Place the pump cover back on and tighten down with the four screws you previously removed.

15. Reattach the power wire and the wire for the priming switch.

16. Put the cover back on the control box and secure with the two screws previously removed.

17. Ensuring that all non-essential personnel are clear of the area, restore power to the unit. Turn the unit on and by using the priming switch, verify that the feeder pump operates and pumps fluid.

18. Replace the front door.



Removing the motor mounting screws.

### **AFTER MAINTENANCE ACTIONS**

None.

### **SPECIAL NOTES**

Work performed on Jackson dishmachines by unauthorized or unqualified personnel may void the warranty. Before beginning this or any other maintenance evolution on a unit under warranty, you should contact a certified Jackson technician or Jackson Technical Service. You can find a list of qualified service agencies in the back of you unit's installation manual.

### **SPECIAL PARTS**

Glasswasher Feeder Pump Motor Replacment Kit:  
06401-003-12-49\*

\*The kit contains a motor and instructions.

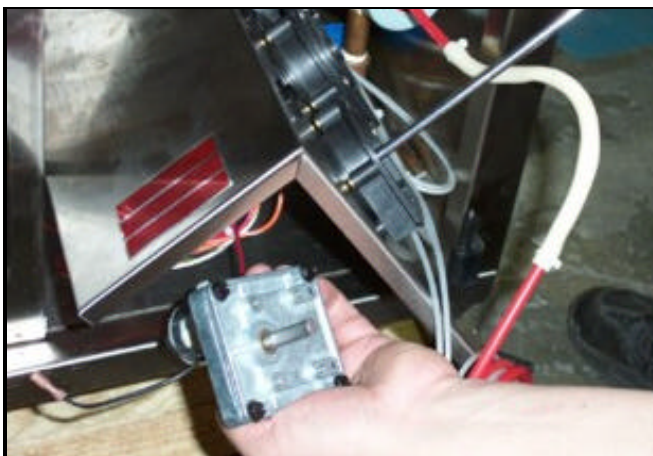

Removing the motor.

---

## SECTION 5: SERVICE PROCEDURES

### WASH TANK HEATER REPLACEMENT

Jackson glasswasher machines come equipped with heaters to ensure proper ware washing results. Occasionally, some of these components may need replacing to maintain optimum performance.

Jackson offers all of the repair parts necessary for performing this task.

The instructions provided here are for maintenance personnel only. Unauthorized persons should not attempt any of the steps contained in these instructions.

**Warning: many of the instructions and steps within this document require the use of tools. Only authorized personnel should ever perform any maintenance procedure on the dishmachine!**

### PREPARATION

1. Power must be secured to the unit at the service breaker. Tag or lock out the service breaker to prevent accidental or unauthorized energizing of the machine.

2. Ensure that incoming water to the machine is secured either by use of a shut-off valve or disconnecting the incoming water line.

3. The unit must be drained completely with the drain stopper removed.

### TOOLS REQUIRED

The following tools will be needed to perform this maintenance evolution:

1. 3/8" Nutdriver
2. Ratchet
3. 1/2" Socket
4. 3/8" Socket
5. Torque Wrench
6. Amp Meter

### TIME REQUIRED

It is estimated that it will take (1) person thirty minutes to perform this task, not including all of the items indicated in the section entitled "PREPARATION".

### IMPORTANT NOTES

1. Read these instructions thoroughly before attempting this maintenance task. Become familiar with the parts and what actions need to be taken. This will save time in the long run!

### STEPS

1. Remove the front door.



Removing the heater cover.

2. Remove the heater box cover with the 3/8" nutdriver to expose the heater. Set the cover and hardware to the side.



Removing the lower strainer.

3. Remove the lower strainer.
4. Remove the upper (wash) strainer as well. Set both strainers to the side where they will not be damaged or present a trip hazard.

---

## SECTION 5: SERVICE PROCEDURES

### WASH TANK HEATER REPLACEMENT (CONTINUED)

---



Removing upper (wash) strainer.

6. Next, use the ratchet and 1/2" socket to remove the heater mounting nuts.



Reaching into the wash tank.

7. Removing the heater may require that you reach into the wash tank, grasp it and give it a push out of the wash tank.



Removing the heater nuts.

5. Using the 3/8" nutdriver, remove the nuts securing the heater wires to the heater. Then carefully pull the wires out of



Pulling the heater out.

8. Once the heater is pushed away from the tank wall, pull it out with your hands.

9. Remove the old heater gasket and throw away.

10. Apply the new heater gasket.

11. Take the new heater and slide it through the hole in the wash tank and line it up so the wash tank studs fit in the holes on the heater flange.

12. Place the mounting nuts and lockwashers on the studs and secure them with the ratchet and 1/2" socket.

13. Place the heater wires on the heater and tighten them down using the 3/8" nutdriver.



the way. Using the ratchet to remove the heater mounting nuts.

---

## SECTION 5: SERVICE PROCEDURES

### WASH TANK HEATER REPLACEMENT (CONTINUED)



Removing the heater gasket

14. Using the torque wrench or a torque nutdriver (if available) torque the nuts holding the wires, jumpers and bus bars to 16 in-lbs.

15. Ensuring that all non-essential personnel are clear of the area, place the drain stopper back in the wash tank and restore power and water to the unit. Turn the unit on and allow it to fill normally.

18. Verify that there are no leaks around the heater. If there are, attempt to tighten it down (with power secured to the unit at the service breaker to prevent injury) as the tank will change shape slightly as it heats up.

19. Use the amp meter to take readings off of the power lines to the heater, verifying the amperage draw to the machine data plate.

20. Wait until the heater contactor kicks out (meaning that the tub has reached the appropriate temperature) and allow the machine to operate approximately ten minutes to verify that there are no leaks and that the heater is maintaining the tank temperature.

21. Replace the heater cover.

23. Replace the front door.

### AFTER MAINTENANCE ACTIONS

Service personnel may want to drain the machine and allow it to cool down. Secure power to the unit at the service breaker and then verify the torque of all fasteners covered in this instruction.

### SPECIAL NOTES

Work performed on Jackson dishmachines by unauthorized or unqualified personnel may void the warranty. Before beginning this or any other maintenance evolution on a unit under warranty, you should contact a certified Jackson technician or Jackson Technical Service. You can find a list of qualified service agencies in the back of your unit's installation manual.

### SPECIAL PARTS

Heater Replacement Kit: 06401-003-12-23\*

\*The kit contains a heater, gasket, mounting hardware for the heater and instructions.

---

## SECTION 5: SERVICE PROCEDURES

### THERMOSTAT REPLACEMENT

Jackson glasswasher machines come equipped with thermostats to ensure proper ware washing results. Occasionally, some of these components may need replacing to maintain optimum performance.

Jackson offers all of the repair parts necessary for performing this task.

The instructions provided here are for maintenance personnel only. Unauthorized persons should not attempt any of the steps contained in these instructions.

**Warning: many of the instructions and steps within this document require the use of tools. Only authorized personnel should ever perform any maintenance procedure on the dishmachine!**

### PREPARATION

1. Power must be secured to the unit at the service breaker. Tag or lock out the service breaker to prevent accidental or unauthorized energizing of the machine.

2. Ensure that incoming water to the machine is secured either by use of a shut-off valve or disconnecting the incoming water line.

3. The unit must be drained completely with the drain stopper removed.

### TOOLS REQUIRED

The following tools will be needed to perform this maintenance evolution:

1. 3/8" Nutdriver
2. 7/16" Nutdriver
3. 7/16" Combination Wrench
4. Needlenose Pliers
5. Phillipshead Screwdriver

### TIME REQUIRED

It is estimated that it will take (1) person twenty minutes to perform this task, not including all of the items indicated in the section entitled "PREPARATION".

### IMPORTANT NOTES

1. Read these instructions thoroughly before attempting this maintenance task. Become familiar with the parts and what actions need to be taken. This will save time in the long run!

### STEPS

1. Remove the front door.



Removing the heater cover.

2. Remove the heater box cover with the 3/8" nutdriver to expose the heater. Set the cover and hardware to the side.



Removing the terminals.

3. Using the pair of needlenosed pliers (if necessary), remove the terminals from the thermostat. Be careful not to damage the terminals or the wires or else they will have to be replaced.

4. Remove the thermostat bracket mounting nuts with the 7/16" nutdriver.

---

## SECTION 5: SERVICE PROCEDURES

### THERMOSTAT REPLACEMENT (CONTINUED)



Removing the thermostat bracket mounting nuts.



Separating the thermostat from the bracket.

5. Remove the thermostat from the mounting bracket with the phillipshead screwdriver.

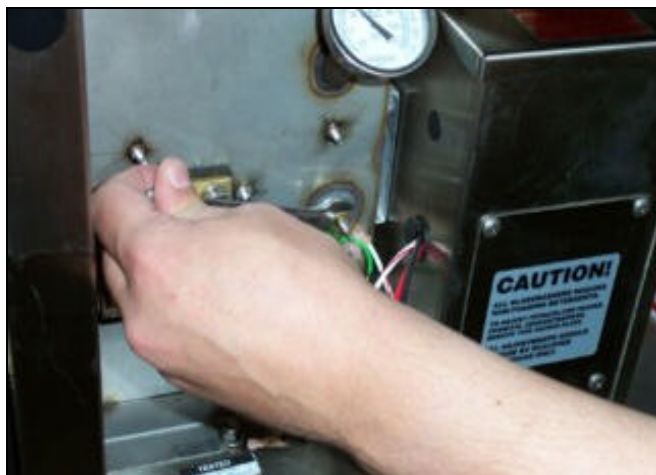

Removing the probe and imperial brass fitting.

6. Use the 7/16" combination wrench to loosen and remove the imperial brass fitting. Once this is complete, you should be able to completely remove the thermostat.

7. Take the new thermostat and place its probe in the new imperial brass fitting provided in your kit. Use the 7/16" combination wrench to tighten it down after getting the fitting hand-tight in the tank.

8. Mount the thermostat to the bracket.

9. Mount the bracket to the tank and tighten down the nuts with the 7/16" nutdriver.

10. Reconnect the wires per the machine schematic on the back of the door.

11. Place the drain stopper back in the wash tank. Restore power and water to the unit. Then allow the unit to operate normally.

12. Verify that the thermostat operates the heater contactor. Once you have determined the heater contactor is working, adjust the wash tank thermostat to ensure that the temperature is maintained in accordance with the specifications on the machine data plate.

13. Replace the heater cover.

14. Replace the front door.

### AFTER MAINTENANCE ACTIONS

None

### SPECIAL NOTES

Work performed on Jackson dishmachines by unauthorized or unqualified personnel may void the warranty. Before beginning this or any other maintenance evolution on a unit under warranty, you should contact a certified Jackson technician or Jackson Technical Service. You can find a list of qualified service agencies in the back of you unit's installation manual.

### SPECIAL PARTS

Thermostat Replacement Kit: 06401-003-12-40\*

\*The kit contains a thermostat, imperial brass fitting, and instructions.



---

## SECTION 5: SERVICE PROCEDURES

### WASH MOTOR REPLACEMENT

Jackson glasswasher machines come equipped with wash pumps that have powerful motors attached to them to ensure proper ware washing results. Occasionally, these assemblies may require replacing to maintain optimum performance.

Jackson offers all of the repair parts necessary for performing this task.

The instructions provided here are for maintenance personnel only. Unauthorized persons should not attempt any of the steps contained in these instructions.

**Warning: many of the instructions and steps within this document require the use of tools. Only authorized personnel should ever perform any maintenance procedure on the dishmachine!**

### PREPARATION

1. Power must be secured to the unit at the service breaker. Tag or lock out the service breaker to prevent accidental or unauthorized energizing of the machine.

2. Ensure that incoming water to the machine is secured either by use of a shut-off valve or disconnecting the incoming water line.

3. The unit must be drained completely with the drain stopper removed.

### TOOLS REQUIRED

The following tools will be needed to perform this maintenance evolution:

1. 1/4" Nutdriver
2. 5/16" Nutdriver
3. Needlenose Pliers
4. 7/16" Combination Wrench
5. (2) 9/16" Combination Wrench

### TIME REQUIRED

It is estimated that it will take (1) person ninety minutes per motor to perform this task, not including all of the items indicated in the section entitled "PREPARATION".

### IMPORTANT NOTES

1. Read these instructions thoroughly before attempting this maintenance task. Become familiar with the parts and what actions need to be taken. This will save time in the long run!

### STEPS

1. To access the assembly, you need to get access to the rear of the unit. This may require that water, drain and power lines be disconnected so that the unit can be moved for access.

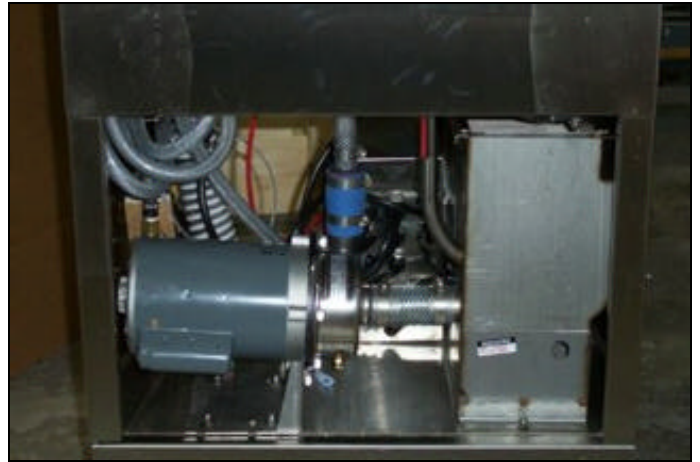

Gain access to the rear of the machine.

2. Using the 5/16" nutdriver, loosen the clamps on the suction hose.



Loosening the suction hose clamps.

3. Using the same nutdriver, loosen the discharge hose where it connects to the tub weldment.

4. Pull the discharge hose out and away from the tub.

5. Remove the motor assembly mounting nuts using the 7/16" combination wrench.

---

## SECTION 5: SERVICE PROCEDURES

### WASH MOTOR REPLACEMENT (CONTINUED)

---



Loosening the discharge hose clamp.



Lifting up on the motor.



Pulling the discharge hose out.

6. With the nuts removed, grasp the motor assembly and lift up on it to clear the mounting studs.

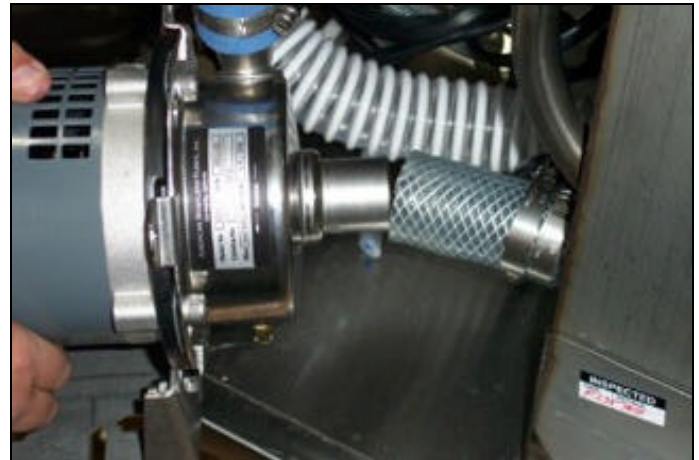

Suction hose coming off when moving the assembly.

7. Turn the motor so that you will have access to the wiring cover on the back. Be careful not to pull or yank too hard as the motor is still connected to the unit by way of the power lines.

8. Use the 1/4" nutdriver to remove the wiring cover.

9. Using the 1/4" nutdriver, remove the grounding screw.

10. Take the needlenose pliers and remove the power wires from the terminals within the motor.

11. Using the cutting jaws of the needlenose pliers, cut the terminals off of the power wires. Cut as close to the terminals as possible (picture provided). Otherwise, you need to remove the conduit completely from the motor and pull it away.



Removing the assembly mounting nuts.

---

**SECTION 5: SERVICE PROCEDURES**  
**WASH MOTOR REPLACEMENT (CONTINUED)**

---



Turn the motor so you can access the rear wiring cover.

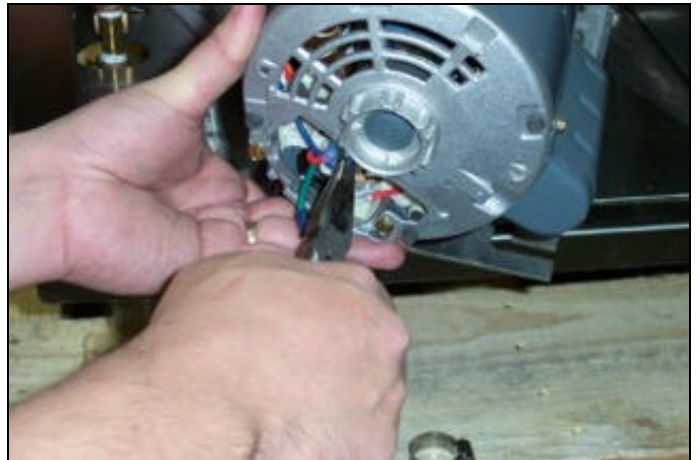

Removing the power wires.



Removing the wiring cover.



Cutting the terminals off of the power wires.



Removing the grounding screw.



Removing the power wires.

---

## SECTION 5: SERVICE PROCEDURES

### WASH MOTOR REPLACEMENT (CONTINUED)

12. Unscrew the conduit fitting from motor and pull out the wires. The assembly should be able to be removed from the unit and set on the floor.



The assembly removed from the unit.

13. With the unit on the floor, remove the discharge hose assembly from the pump end.



Removing the mounting bracket.

14. Use the two 9/16" combination wrenches to remove the bracket from the assembly.

15. Dispose of the old assembly in accordance with proper warranty procedures if applicable.

16. Take the new motor assembly and attach to the mounting bracket.

17. Run the power wires to the motor, strip the insulation off of the wire ends and add terminals. Rewire the motor in accordance with the machine schematic, which is located on the back of the door.

18. Replace and secure the wire access cover and tighten down the conduit nut.

19. Place the discharge hose assembly back on the discharge of the pump and tighten down.

20. Lift the assembly into place within the unit, ensuring that the suction hose is attached and lines up. Move the assembly so the mounting bracket slides over the mounting studs. Position the assembly so that the suction hose is not kinked.

21. Replace and tighten down the nuts securing the bracket to the frame.

22. Tighten the clamps for the suction hose.

23. Connect the discharge hose to the tub and tighten down the hose clamp.

### AFTER MAINTENANCE ACTIONS

Verify the operation of the new wash motor and pump assembly by running the unit for approximately 15 minutes. Check for leaks and correct as necessary.

### SPECIAL NOTES

Work performed on Jackson dishmachines by unauthorized or unqualified personnel may void the warranty. Before beginning this or any other maintenance evolution on a unit under warranty, you should contact a certified Jackson technician or Jackson Technical Service. You can find a list of qualified service agencies in the back of your unit's installation manual.

### SPECIAL PARTS

Motor Bracket Replacement Kit:  
06401-003-12-60\*

Wash Motor Replacement Kit  
06401-003-12-62\*\*

\*The kit contains a bracket and locknuts.

\*\*The kit contains the wash motor, pump and hardware.

---

# **SECTION 6: PARTS SECTION**

## SECTION 6: PARTS SECTION

### CONTROL BOX ASSEMBLY R24

\*A relay was used on earlier models. If service is needed, replace with contactor.

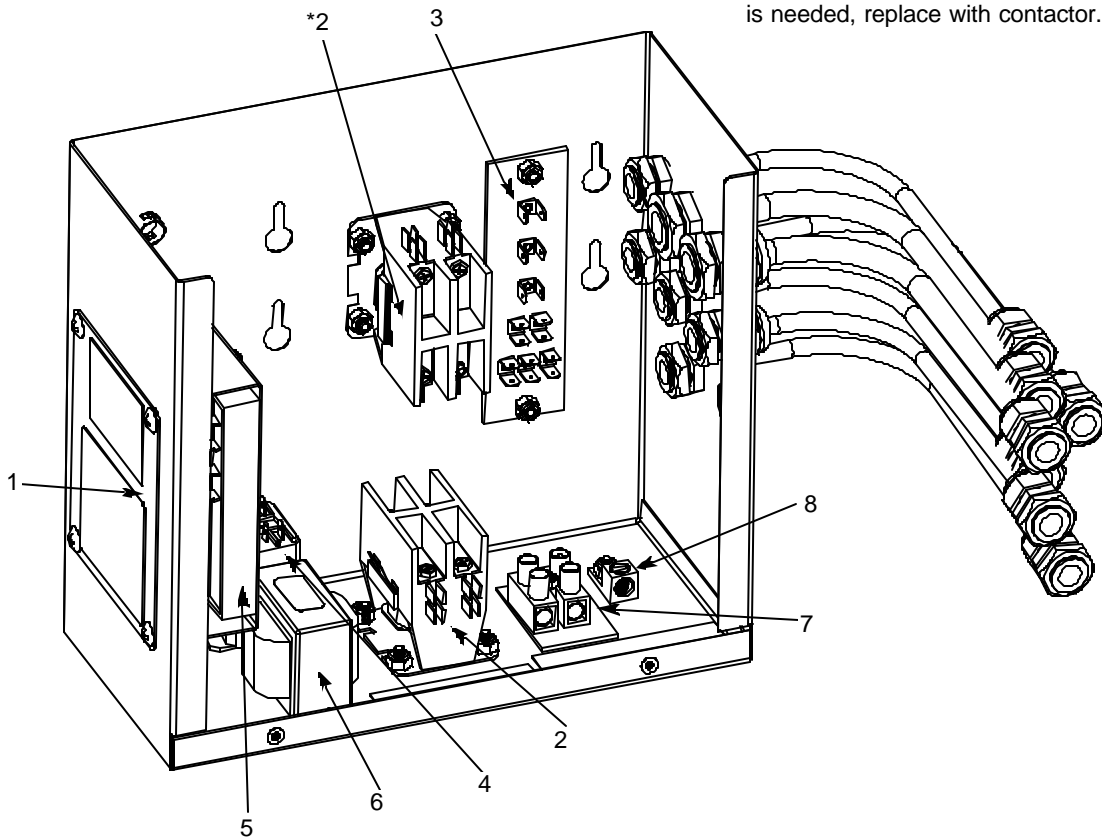

ITEM	QTY	DESCRIPTION	Mfg. No.
1	1	Electrical Box Cover Replacement Kit (Kit contains electrical box cover, decals and mounting hardware)	06401-003-12-07
		Decal, Warning-Disconnect Power	09905-100-75-93
		Decal, Caution	09905-011-68-99
2	2	Contactor	05945-002-74-20
3	1	Terminal Board	05940-002-78-97
4	1	Relay	05945-111-47-51
5	1	Speed Control Board Replacement Kit (Kit contains the speed control board and decal)	06401-003-12-11
		Speed Control Board Bracket	05700-021-61-11
		Speed Control Board Assembly Replacement Kit (Kit contains the speed control board, decal, bracket and mounting hardware)	06401-003-12-10
6	1	Transformer	05950-011-61-67
7	1	Terminal Block Replacement Kit (Kit contains terminal block, spacer and hardware)	06401-003-11-78
8	1	Ground Lug	05940-200-76-00
*	1	Decal, Power Connection	09905-011-62-72
*	1	Decal, Copper Conductors Only	09905-011-64-71

**SECTION 6: PARTS SECTION**  
**ELECTRICAL BOX COVER ASSEMBLY R24**

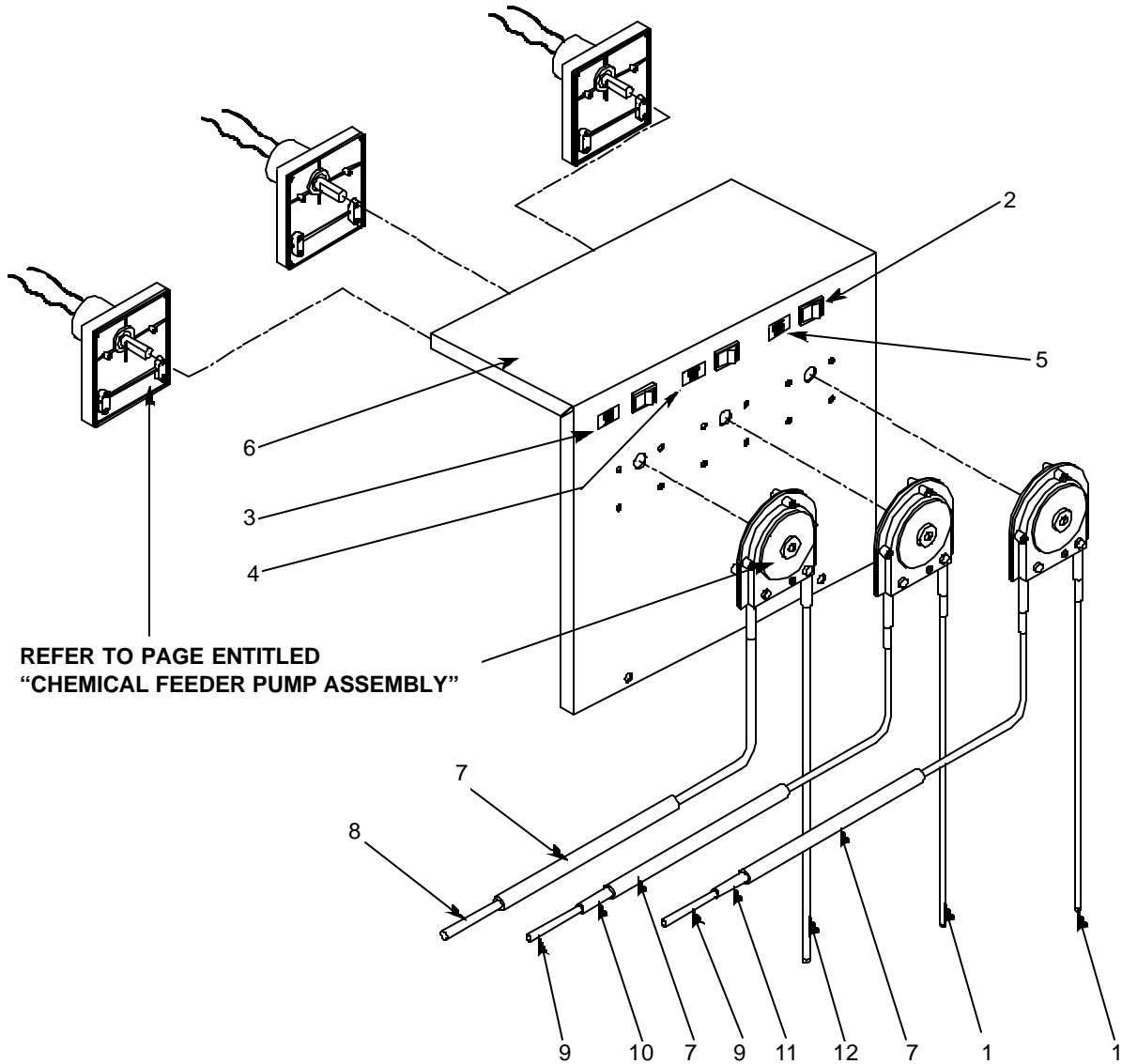

ITEM	QTY	DESCRIPTION	Mfg. No.
1	1	Tube, 1/8" x 35" Clear	05700-011-63-14
2	3	Switch, Prime	05930-011-49-54
3	1	Decal, Detergent Prime	09905-011-64-80
4	1	Decal, Rinse Prime	09905-011-64-81
5	1	Decal, Sanitizer Prime	09905-011-65-22
6	1	Electrical Box Cover Replacement Kit (Kit contains cover, decals and mounting hardware)	06401-003-12-14
7	3	Tube, Stiffener	05700-002-94-47
8	1	Tube, Red 1/4" x 60"	05700-011-63-18
9	1	Tube, Clear 1/8" x 60"	05700-011-63-19
10	1	Tube, Clear 1/4" x 15"	05700-011-63-17
11	1	Tube, Blue 1/4 x 15	05700-011-63-15
12	1	Tube, Red 1/4" x 35"	05700-011-63-16

## SECTION 6: PARTS SECTION

### CONTROL BOX ASSEMBLY R30

\*A relay was used on earlier models. If service is needed, replace with contactor.

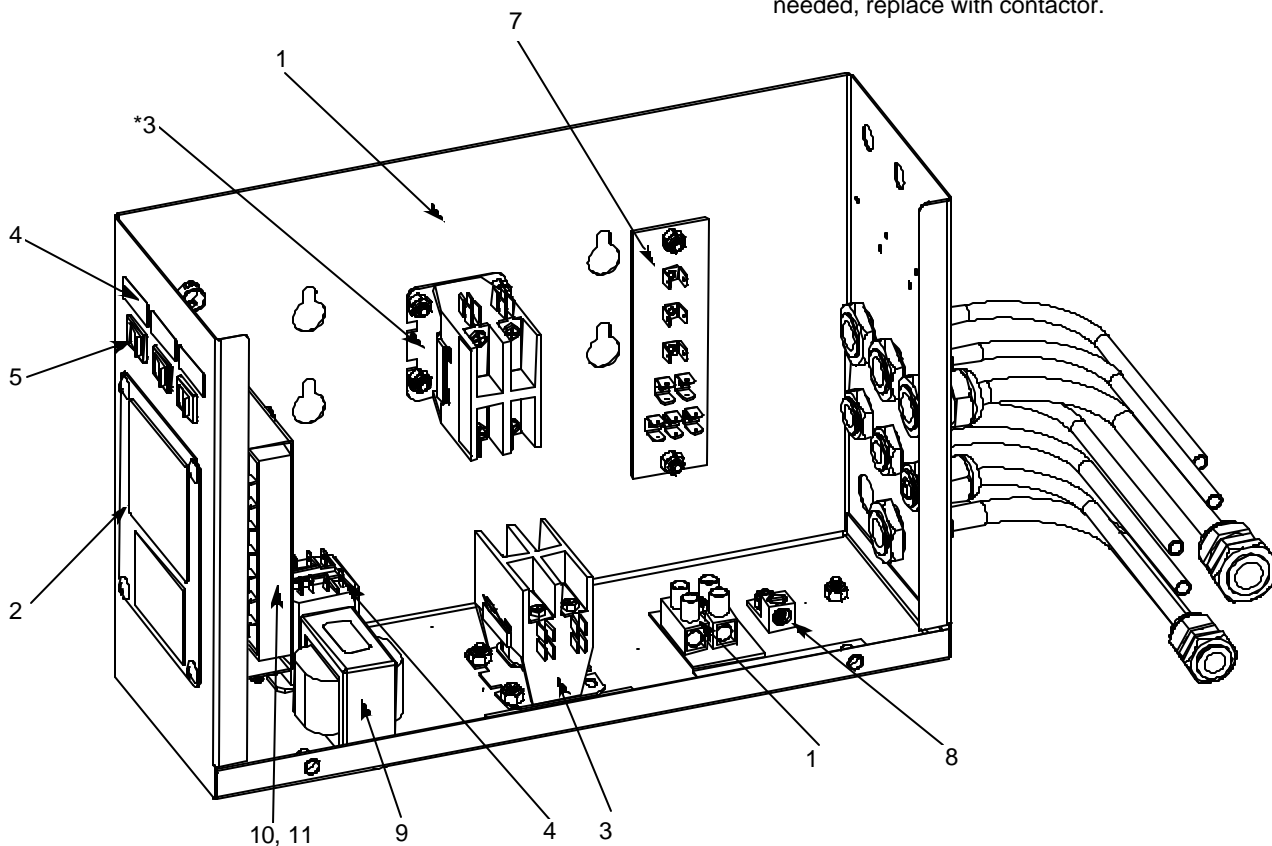

ITEM	QTY	DESCRIPTION	Mfg. No.
1	1	Terminal Block Replacement Kit (Kit contains terminal block, spacer and mounting hardware)	06401-003-11-78
2	1	Electrical Box Cover Replacement Kit (Kit contains cover, decals and mounting hardware)	06401-003-12-07
*	1	Decal, Warning-Disconnect Power	09905-100-75-93
*	1	Decal, Caution	09905-011-68-99
3	2	Contactor	05945-109-03-69
4	1	Decal, Detergent Prime	09905-011-64-80
4	1	Decal, Rinse Prime	09905-011-64-81
4	1	Decal, Sanitizer Prime	09905-011-65-22
5	3	Switch, Prime	05930-011-49-54
6	1	Relay	05945-111-47-51
7	1	Terminal Board	05940-002-78-97
8	1	Ground Lug	05940-200-76-00
*	1	Decal, Power Connection	09905-011-62-72
*	1	Decal, Copper Conductors Only	09905-011-64-71
9	1	Transformer	05950-011-61-67
10	1	Liquid Level Control	06680-011-61-68
11	1	Speed Control Board Replacement Kit (Kit contains the speed control board and decal)	06401-003-12-11
		Speed Control Board Bracket	05700-021-61-11
		Speed Control Board Assembly Replacement Kit (Kit contains the speed control board, decal, bracket and mounting hardware)	06401-003-12-10



**SECTION 6: PARTS SECTION**  
**ELECTRICAL BOX COVER ASSEMBLY R30**

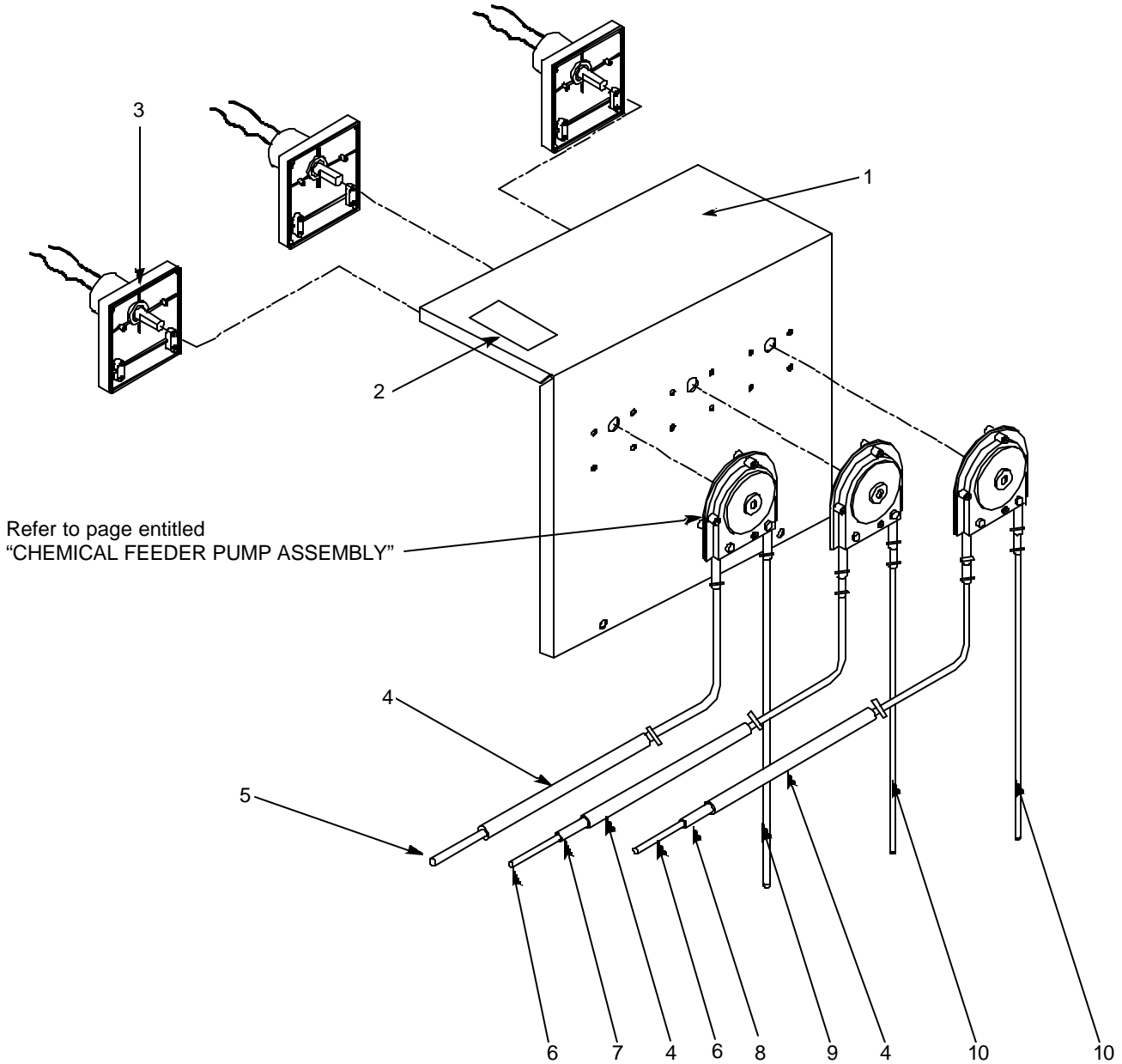

ITEM	QTY	DESCRIPTION	Mfg. No.
1	1	Top, Electrical Box	05700-002-15-28
2	1	Decal, Warning	09905-100-75-93
3	3	Motor, Chemical Feeder Pump, 14 RPM	04320-011-63-33
4	3	Tube, Stiffener	05700-002-94-47
5	1	Tube, Red 1/4" x 60"	05700-011-63-18
6	1	Tube, Clear 1/8" x 60"	05700-011-63-19
7	1	Tube, Clear 1/4" x 15"	05700-011-63-17
8	1	Tube, Blue 1/4 x 15"	05700-011-63-15
9	1	Tube, Red 1/4" x 35"	05700-011-63-16
10	1	Tube, 1/8" x 35" Clear	05700-011-63-14

**SECTION 6: PARTS SECTION**  
**CHEMICAL FEEDER PUMP ASSEMBLY**

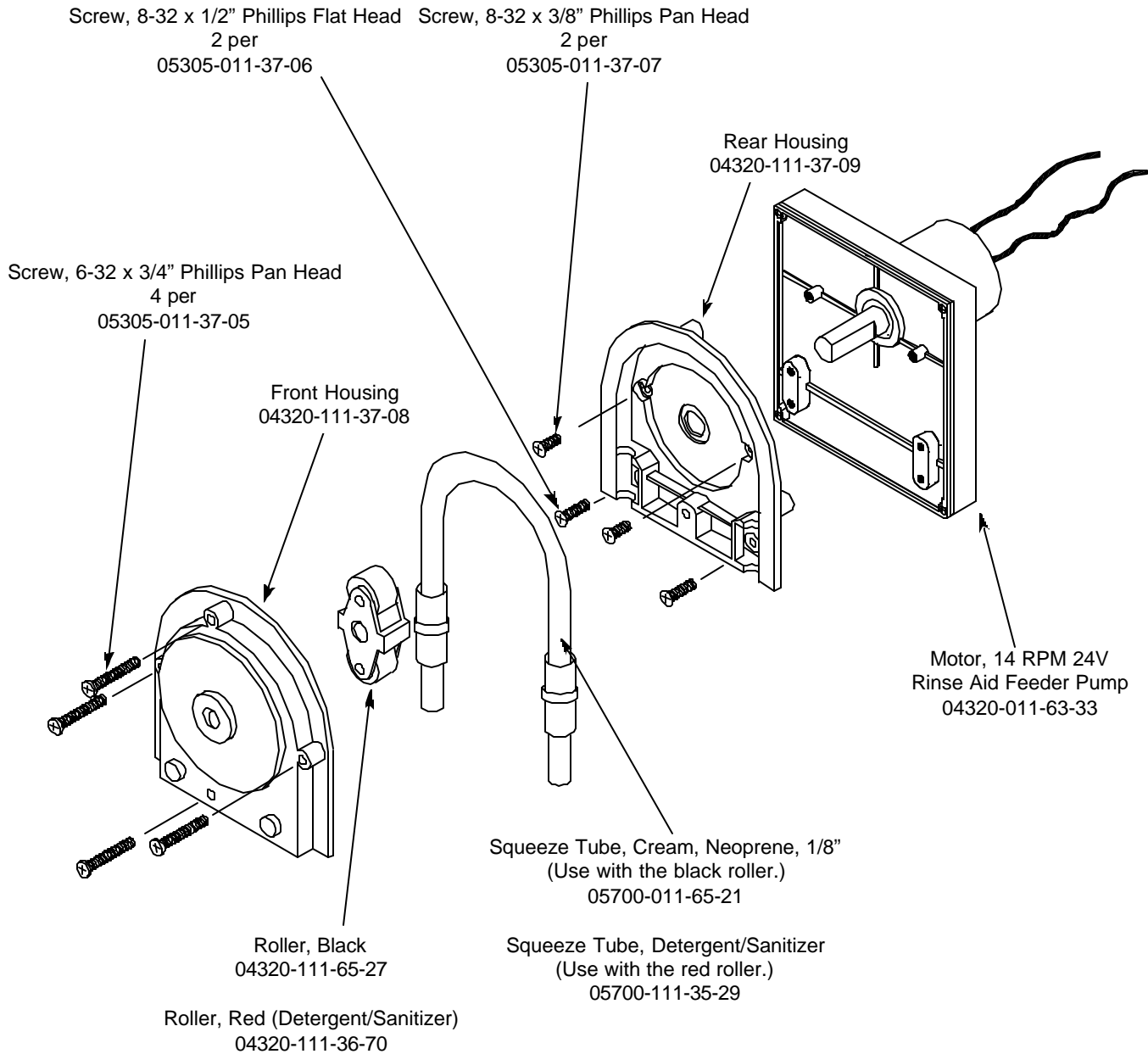

## SECTION 6: PARTS SECTION

### DRIVE MOTOR ASSEMBLY

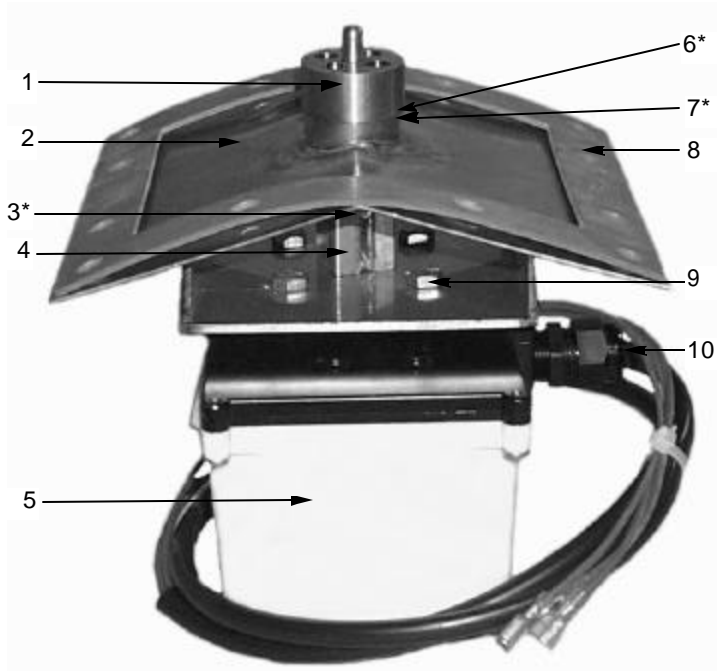

ITEM	QTY	DESCRIPTION	Mfg. No.
1	1	Drive Hub Weldment	05700-002-15-29
2	1	Gear Box Weldment	05700-002-17-40
3*	1	Hair Pin, 1/8" S/S	05315-002-15-39
4	1	Space Sleeve	05700-002-16-83
5	1	Gearmotor, Clockwise Rotation	06105-002-15-41
5	1	Gearmotor, Counter Clockwise Rotation	06105-002-15-40
6*	2	O-Ring, 7/16" I.D. x 9/16" O.D.	05330-002-15-44
7*	1	Washer, Drive Hub	05700-002-17-97
8	1	Gasket, Gear Case	05330-001-99-64
9	4	Bolt, 5/16"-18 x 5/8" Hex Head	05305-275-09-00
10	2	Connector, Liquid Tite, .27" to .48"	05975-011-59-50

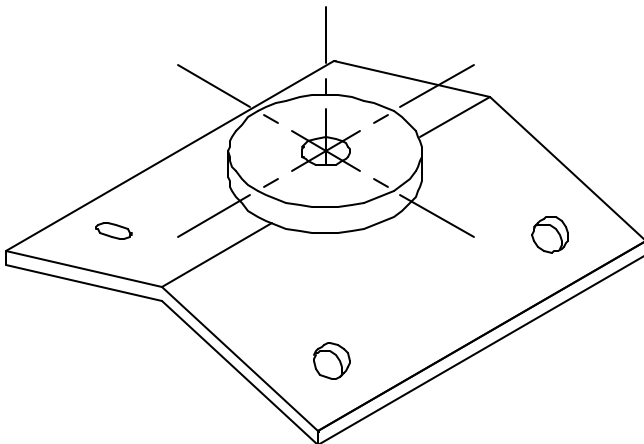

**NOTE: THIS STYLE OF ASSEMBLY APPLIES ONLY TO MACHINES WITH SERIAL NUMBERS 99E 1819 AND LOWER.**

**SERVICE NOTE: ONCE THE RACK HUB SLEEVE IS PRESSED IN, IT IS RECOMMENDED TO REAM/DRILL THE HOLE TO 5/16" DIAMETER.**

Hub Sleeve Assembly Replacement Kit: 06401-003-12-36  
(Includes the hub sleeve, hub plate and mounting hardware)

Hub Sleeve: 05700-011-61-07

## SECTION 6: PARTS SECTION

### DRIVE ASSEMBLY RETRO FIT KIT NO. 1

**NOTE: APPLIES TO UNITS WITH SERIAL NUMBERS 00B 2023 AND HIGHER ONLY.**

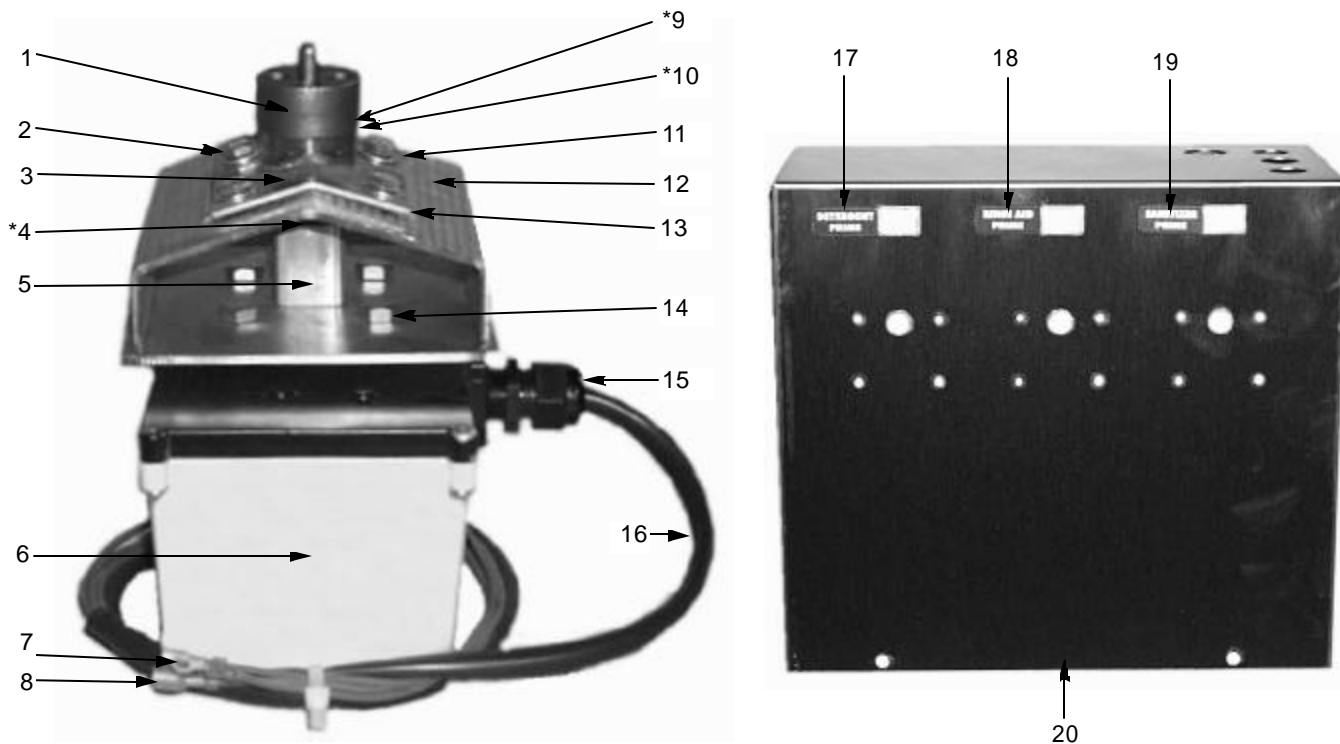

The complete Clockwise Drive Assembly Kit may be ordered using part number 05700-002-22-60.  
 The complete Counter Clockwise Drive Assembly Kit may be ordered using part number 05700-002-22-79.

The only difference in these two kits is the directional motor that is chosen.

\*Represents an item not shown

ITEM	QTY	DESCRIPTION	Mfg. No.
1	1	Drive Hub	05700-002-15-29
2	4	Screw, 1/4"-20 x 1/2" S/S Hex Head	05305-274-02-00
3	1	Sleeve Hub Weldment	05700-002-22-65
*4	1	Hair Pin, 1/8" S/S	05315-002-15-39
5	1	Spacer, Sleeve	05700-002-16-83
6	1	Gearmotor, Clockwise Rotation	06105-002-15-41
6	1	Gearmotor, Counter Clockwise Rotation	06105-002-15-40
7	1	Terminal, # 6 Ring, Red Insulated	05940-200-72-00
8	2	Terminal, BLT RECPT	05940-200-56-00
*9	1	Washer, Drive Hub	05700-002-17-97
*10	2	O' Ring, 7/16" I.D. x 9/16" O.D.	05330-002-15-44
11	4	Washer, 1/4"-20 I.D. S/S	05311-174-01-00
12	1	Housing Coupling Weldment	05700-002-22-64
13	1	Gasket, Rack Hub Plate	05330-011-61-09
14	4	Bolt, 5/16"-18 X 5/8" Hex Head	05305-275-09-00
15	2	Connector, Liquid Tite, .27" to .48"	05975-011-59-50
16	1	Voltex, 7/16" x 36" Long	05700-002-22-66
17	1	Decal, Detergent Prime	09905-011-64-80
18	1	Decal, Rinse Prime	09905-011-64-81
19	1	Decal, Sanitizer Prime	09905-011-65-22
20	1	Cover, Control Box	05700-002-22-78

## SECTION 6: PARTS SECTION

### DRIVE ASSEMBLY RETRO FIT KIT NO. 2

**NOTE: APPLIES TO UNITS WITH SERIAL NUMBERS 00B 2023 AND HIGHER ONLY.**

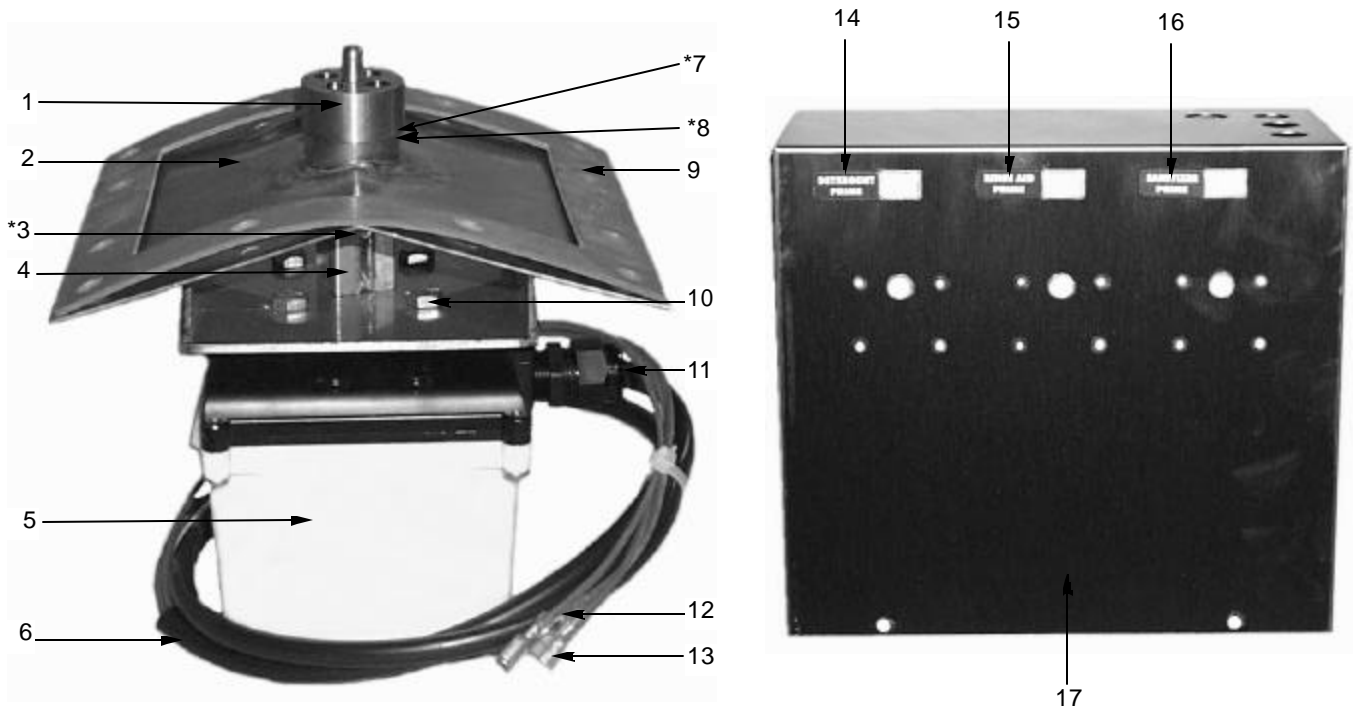

The complete Clockwise Drive Assembly Kit may be ordered using part number 05700-002-22-61.  
 The complete Counter Clockwise Drive Assembly Kit may be ordered using part number 05700-002-22-80.

The only difference in these two kits is the directional motor that is chosen.

\*Represents an item not shown

ITEM	QTY	DESCRIPTION	Mfg. No.
1	1	Drive Hub	05700-002-15-29
2	1	Gear Box Weldment	05700-002-17-40
*3	1	Hair Pin, 1/8" S/S	05315-002-15-39
4	1	Spacer Sleeve	05700-002-16-83
5	1	Gearmotor, Clockwise Rotation	06105-002-15-41
5	1	Gearmotor, Counter Clockwise Rotation	06105-002-15-40
6	1	Voltex, 7/16" x 36" Long	05700-002-22-66
*7	2	O' Ring, 7/16" I.D. x 9/16" O.D.	05330-002-15-44
*8	1	Washer, Drive Hub	05700-002-17-97
9	1	Gasket, Gear Case	05330-001-99-64
10	4	Bolt, 5/16"-18 X 5/8" Hex Head	05305-275-09-00
11	2	Connector, Liquid Tite, .27" to .48"	05975-011-59-50
12	2	Terminal, BLT RECPT	05940-200-56-00
13	1	Terminal, # 6 Ring, Red Insulated	05940-200-72-00
14	1	Decal, Detergent Prime	09905-011-64-80
15	1	Decal, Rinse Prime	09905-011-64-81
16	1	Decal, Sanitizer Prime	09905-011-65-22
17	1	Cover, Control Box	05700-002-22-78
*18	12	Screw, 1/4"-20 x 5/8" S/S Hex Head	05305-274-24-00
*19	24	Washer, 1/4"-20 I.D. S/S	05311-174-01-00
*20	12	Locknut, 1/4"-20 Hex w/Nylon Insert	05310-374-01-00

## SECTION 6: PARTS SECTION

### DRIVE GEAR ASSEMBLY

**NOTE: APPLIES TO UNITS WITH SERIAL NUMBERS  
99E 1820 THROUGH 00B 2023 ONLY.**

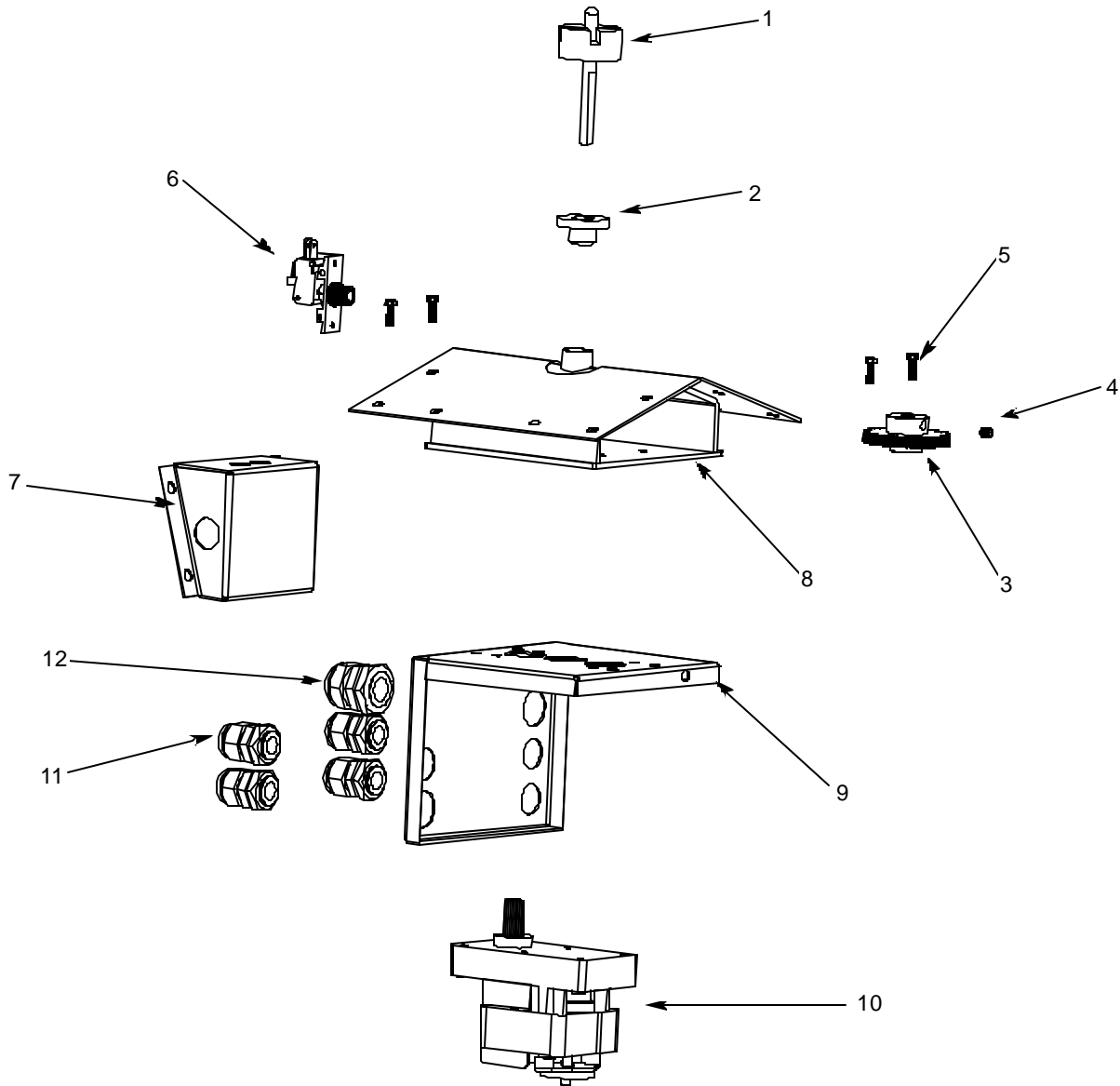

ITEM	QTY	DESCRIPTION	Mfg. No.
1	1	Hub	05700-011-61-21
2	1	Hub Spacer	05700-011-61-07
3	1	Gear	06105-011-70-88
4	1	Screw, Set, 1/4" - 20	05305-002-10-14
5	4	Bolt, Hex, 10-32 x 3/8" Long	05306-011-63-29
6	1	Limit Switch	05930-011-61-65
7	1	Switch Box Weldment	05700-021-62-41
8	1	Gear Box Weldment	05700-002-02-45
9	1	Motor Mounting Box	05700-002-00-61
10	1	Gear Drive Motor	06105-011-70-80
11	4	Liquid Tight Fitting	05975-011-49-03
12	1	Liquid Tight Fitting	05975-011-65-51

## SECTION 6: PARTS SECTION

### DRIVE MOTOR ASSEMBLY

**NOTE: APPLIES TO UNITS WITH SERIAL NUMBERS 99E 1819 AND LOWER ONLY.**

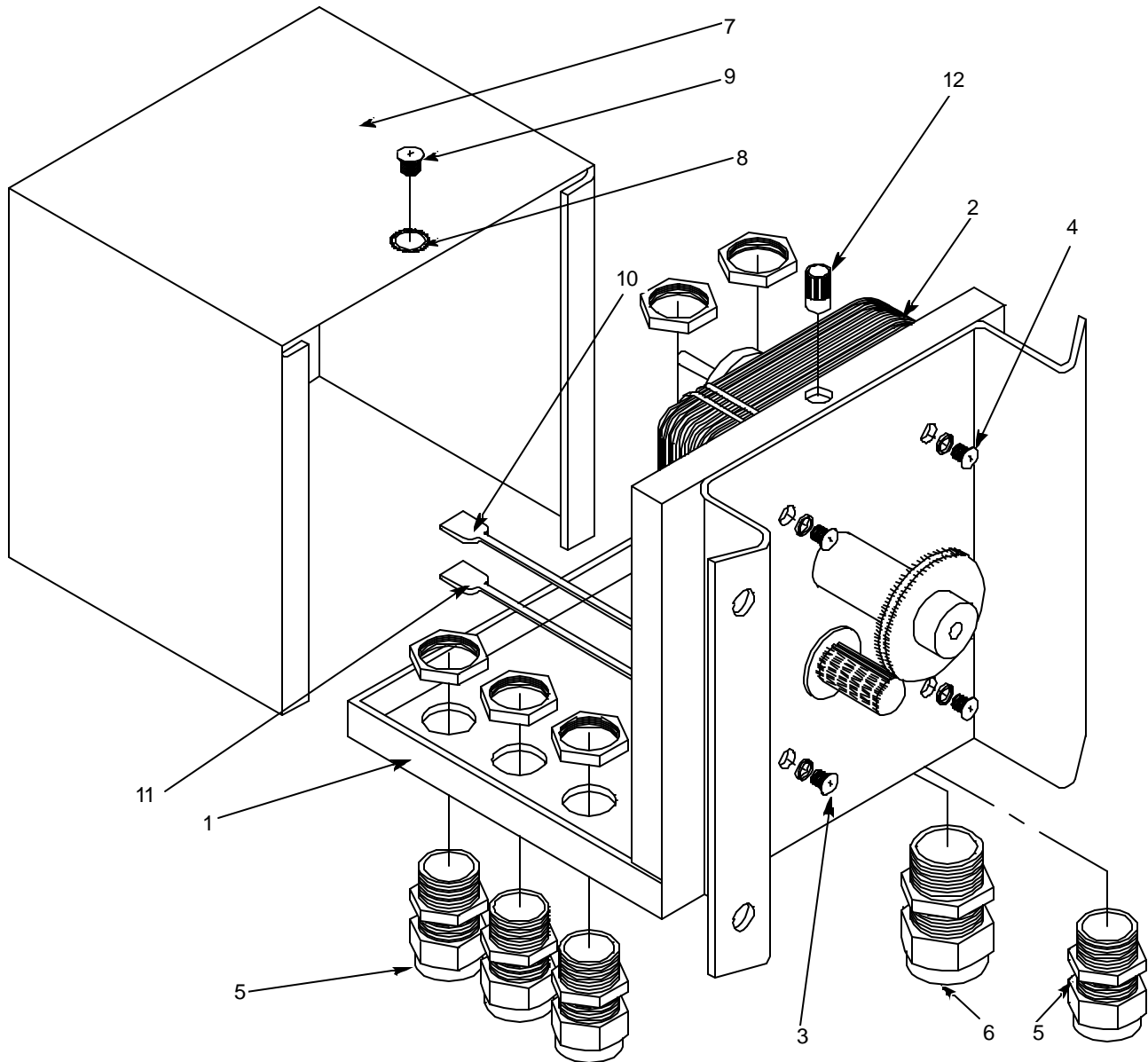

ITEM	QTY	DESCRIPTION	Mfg. No.
1	1	Mounting Plate Cover	05700-011-70-20
2	1	Gearmotor, AC Unidirectional	06105-011-70-80
3	4	Screw, 8-32 x 3/8" Long, Round Head	05305-172-02-00
4	4	Lockwasher, #8, External Tooth	05311-272-01-00
5	4	Fitting, Liquid Tight, .231 ID x .394 OD	05975-011-49-03
6	1	Connector, Liquid Tight, .27" to .48"	05975-011-59-50
7	1	Cover, Motor Mounting	05700-021-62-40
8	1	Starwasher, #10-24, External Tooth	05311-273-02-00
9	1	Screw, 10-32 x 3/8" Long, Truss Hd.	05305-173-12-00
10	2	Terminal, Bullet, Red	05940-200-74-00
11	3	Terminal, Bullet, Recpt, Red	05940-200-56-00
12	1	AK Fastener, 10-32	05340-111-58-10

## SECTION 6: PARTS SECTION

### INCOMING PLUMBING ASSEMBLY

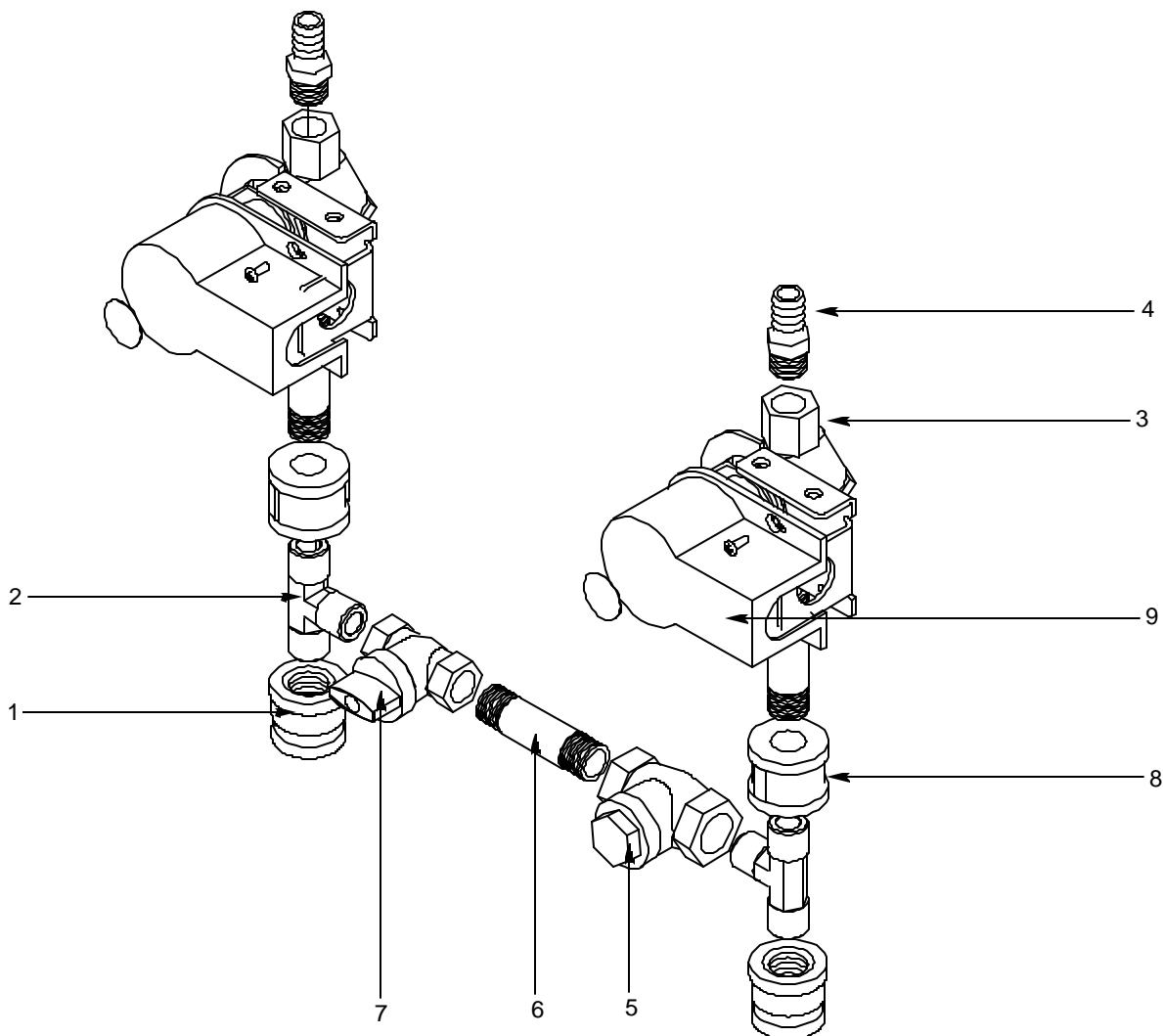

ITEM	QTY	DESCRIPTION	Mfg. No.
1	2	Coupling, 1/2" FNPT x 3/8" FNPT, Brass	04730-011-61-52
2	2	Tee, 3/8" x 3/8" x 3/8" MNPT, Brass	04730-011-61-53
3	2	S-45 Solenoid Valve, 240V	04730-011-61-54
4	2	Elbow, 3/8" MNPT x 90° to 1/2" Barb	04730-002-18-54
5	2	Check Valve, Flap, 3/8" FNPT x 3/8" FNPT	04820-011-61-56
6	3	Nipple, 3/8" MNPT x 2-1/2" Long	04730-011-61-57
7	1	Ball Valve, 3/8" FNPT x 3/8" FNPT	04820-011-61-58
8	2	3/8" Brass Coupling	04730-011-62-56
9		Kit, S-45 Valve Cover Replacement (Kit contains cover, mounting screws and decals)	06401-003-12-76



---

**SECTION 6: PARTS SECTION**  
**INJECTION MANIFOLD**

---

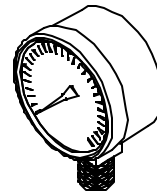
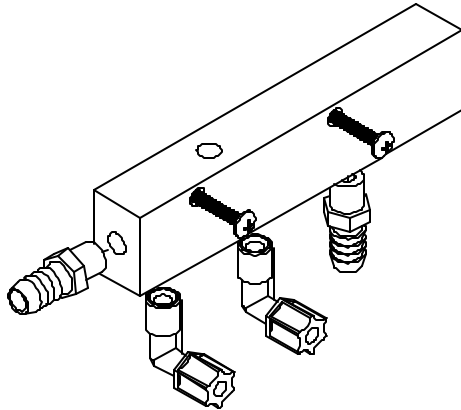

Pressure Gauge  
06685-011-64-29

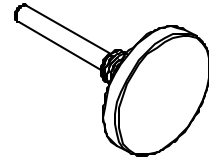

Thermometer  
06685-111-35-30

Injection Manifold Replacement Kit  
(Kit contains manifold, fittings and hardware)  
06401-003-12-65

Note: Use thread tape when putting in new fittings.

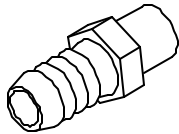

Fitting, 1/4" NPT x 1/2" Barbed  
04730-011-61-62

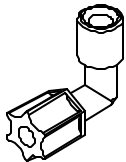

Fitting, Elbow, 1/4" NPT, Plastic  
04730-111-48-87

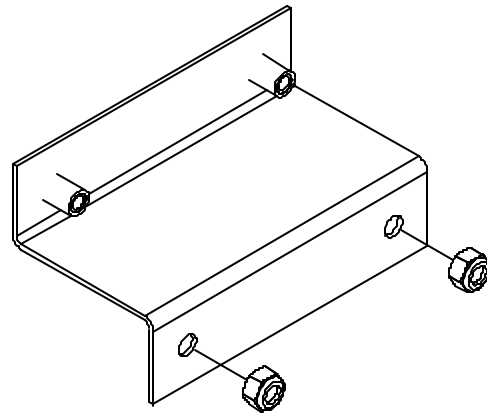

Injection Manifold Mounting Bracket Replacement Kit  
(Kit contains bracket and mounting hardware)  
06401-003-12-66

## SECTION 6: PARTS SECTION

### VACUUM BREAKER ASSEMBLY/WASH FILL COMPONENTS

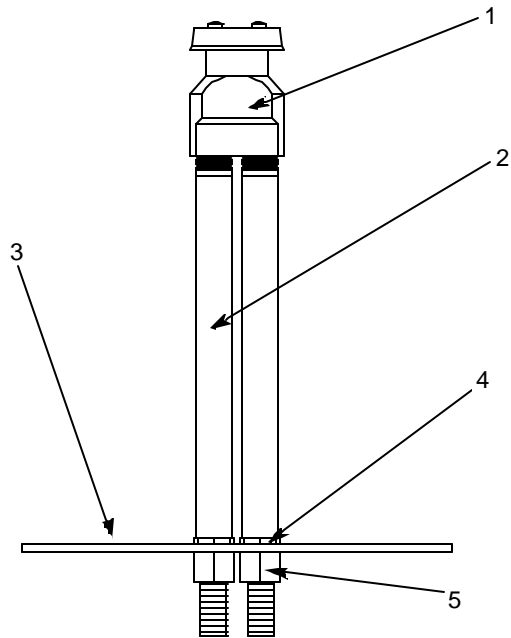

Vacuum Breaker Rinse Fill Hose Replacement Kit  
(Kit contains hose and hose clamps)

R24: 06401-003-12-33

R30: 06401-003-12-72

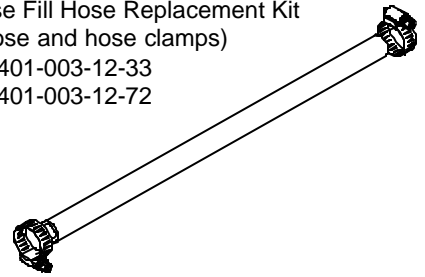

Wash Fill Hose Replacement Kit  
(Kit contains hose and hose clamps)

R24: 06401-003-12-34

R30: 06401-003-12-73

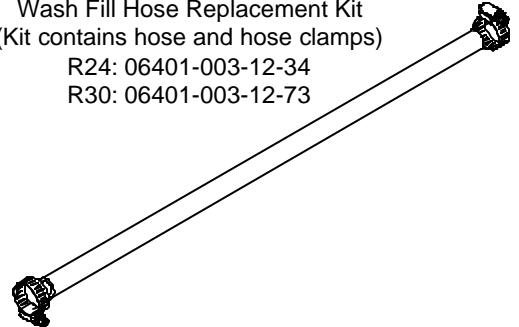

ITEM	QTY	DESCRIPTION
1	1	Vacuum Breaker 3/8"
2	2	Nipple, 3/8" NPT x 8" Long
3	1	Plate, Vacuum Breaker
4	2	Jam Nut
5	2	3/8" NPT x 1/2" ID Hose Barb

#### Mfg. No.

04820-011-61-43

05700-021-61-44

05700-011-61-46

05310-011-61-45

04730-011-61-47

#### FILL VACUUM ASSEMBLY

#### RINSE VACUUM ASSEMBLY

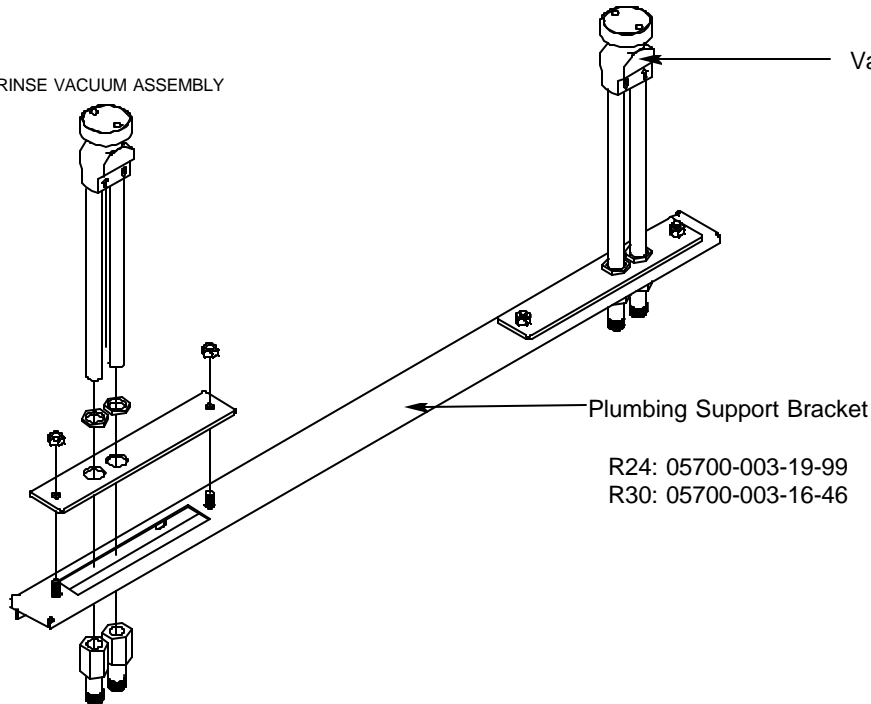

Vacuum Breaker Assembly

2 per assembly

05700-021-61-42



Hold Down Clamp

05700-000-35-06

Plumbing Support Bracket

R24: 05700-003-19-99

R30: 05700-003-16-46

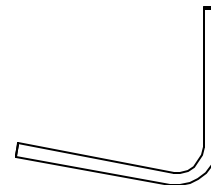

Wash Fill Tube

05700-021-63-01

## SECTION 6: PARTS SECTION

### WASH TANK ASSEMBLY

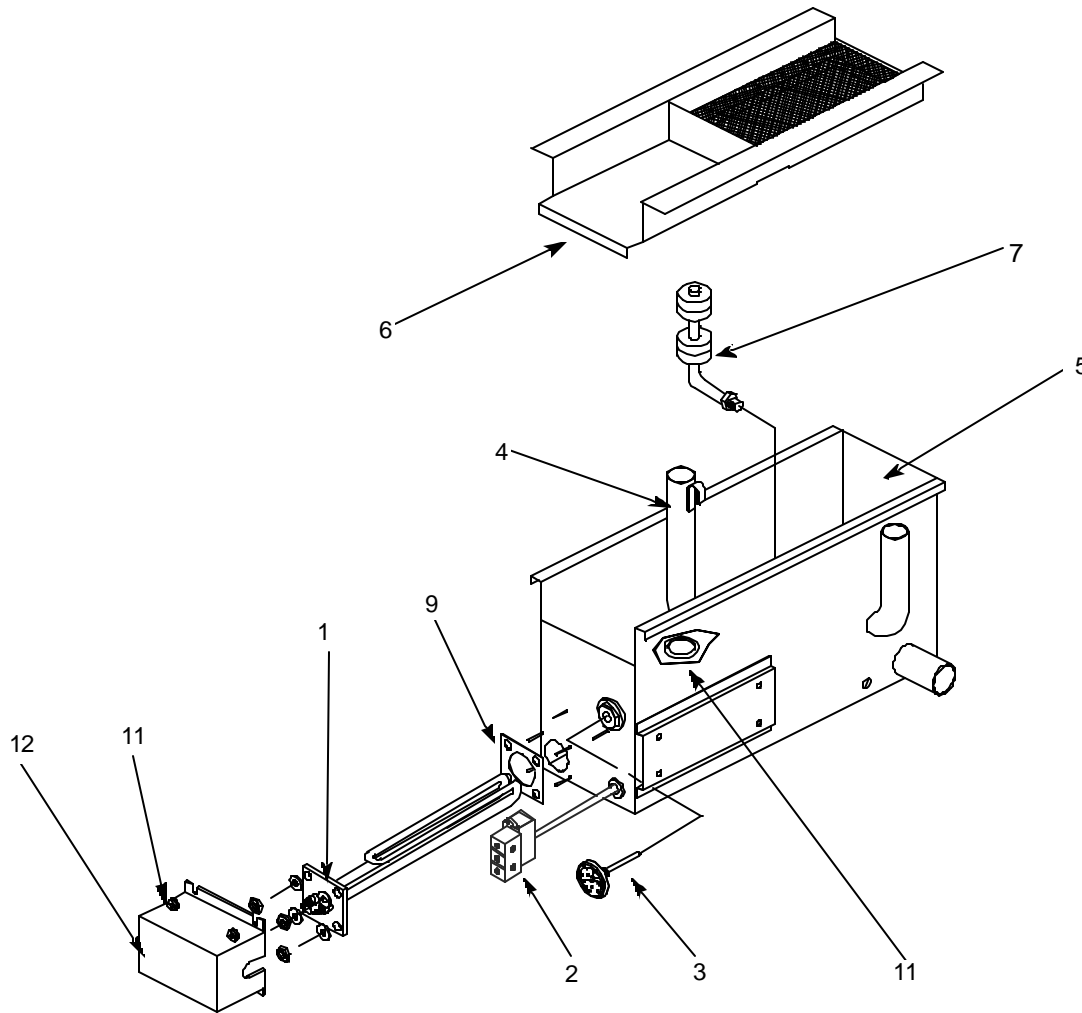

ITEM	QTY	DESCRIPTION	Mfg. No.
1	1	Wash Heater Replacment Kit (Kit contains wash heater, gasket, mounting hardware and instructions)	06401-003-12-23
2	1	Thermostat Replacement Kit (Kit contains thermostat, imperial brass fitting and instructions)	06401-003-12-40
*	1	Decal, High Limit	09905-011-84-32
*	1	Bracket, Thermostat Mounting	05700-011-81-64
3	1	Thermometer	06685-111-35-30
4	1	Overflow Tube Weldment	05700-021-62-22
*	1	Overflow Support Bracket	05700-002-33-72
5	1	Wash Tank Weldment Replacement Kit (R24)	06401-003-13-31
	1	Wash Tank Weldment Replacement Kit (R30) (Kits contains the wash tank weldment and a new O-ring)	06401-003-12-24
6	1	Wash Strainer Weldment (R24)	05700-021-61-78
6	1	Wash Strainer Weldment (R30)	05700-001-98-86
7	1	Float Switch Replacement Kit (Kit contains float switch and mounting hardware)	06401-003-11-76
9	1	Wash Heater Gasket	05330-011-61-34
11	1	O-Ring	05330-400-05-00
12	2	Heater Cover Weldment Replacement Kit (Kit contains the heater cover with warning decal and mounting hardware)	06401-003-12-78

---

**SECTION 6: PARTS SECTION**  
**RINSE SUMP ASSEMBLY/WASH AND RINSE ARMS**

---

**Rinse Strainer Weldment**

R24: 05700-021-61-79

R30: 05700-001-98-88

**Drain Weldment**

R24: 05700-031-61-99

R30: 05700-001-98-78

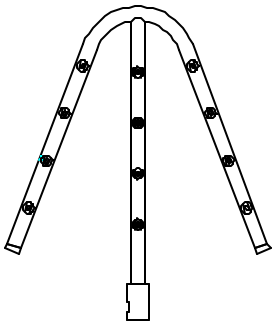
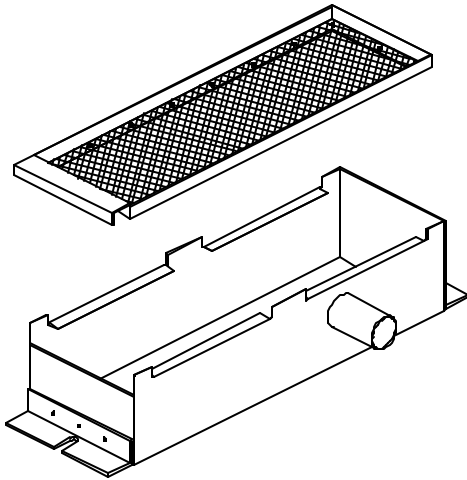

R24 Wash Arm  
2 Per Unit  
05700-031-60-84

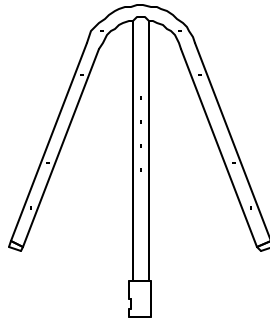

R24 Rinse Arm  
2 Per Unit  
05700-031-61-23

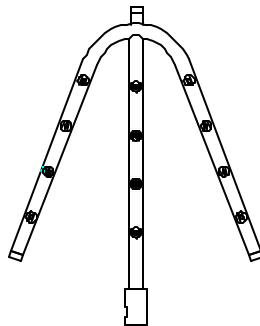

R30 Wash Arm  
2 Per Unit  
05700-001-99-06

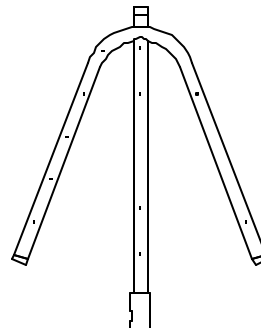

R30 Rinse Arm  
2 Per Unit  
05700-001-99-07

---

**SECTION 6: PARTS SECTION**  
**WASH MOTOR REPLACEMENT KITS**

---

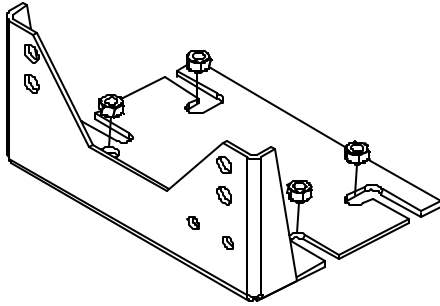

Motor Mounting Bracket Replacement Kit  
(Contains the bracket and mounting locknuts)  
06401-003-12-60

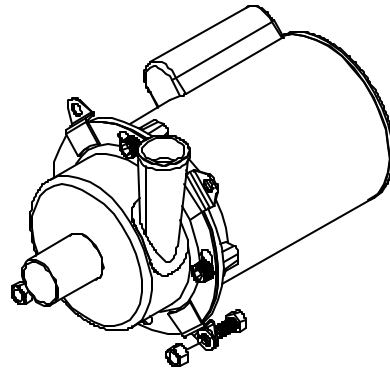

Motor Replacement Kit  
(Contains motor, pump and hardware for mounting to bracket)  
06401-003-12-62

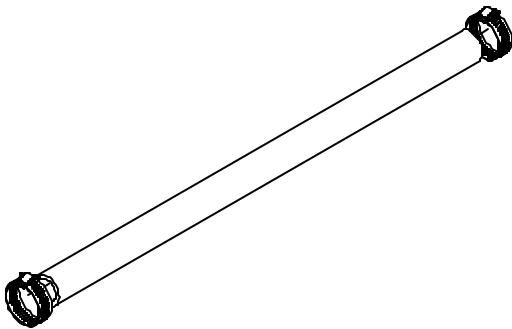

Upper Discharge Hose Replacement Kit (R24)  
(Contains hose and hose clamps)  
06401-003-12-32

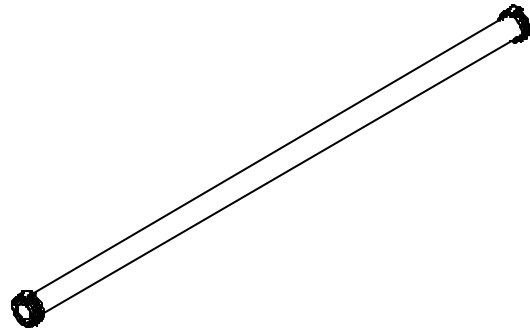

Upper Discharge Hose Replacement Kit (R30)  
(Contains hose and hose clamps)  
06401-003-12-67

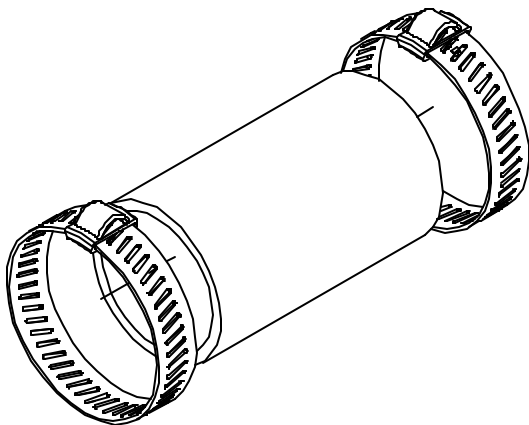

Suction Hose Replacement Kit (R24)  
(Contains hose and hose clamps)  
06401-003-12-30

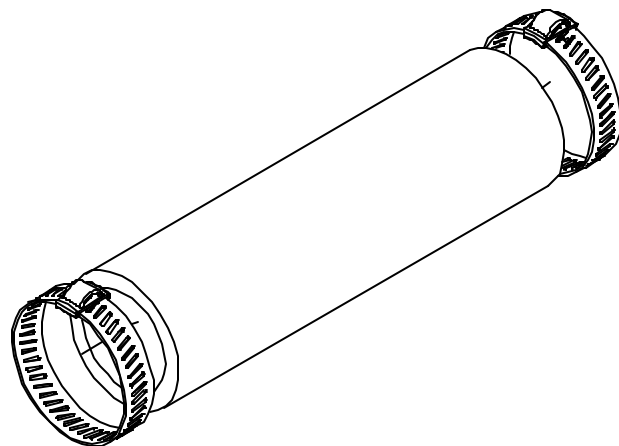

Suction Hose Replacement Kit (R30)  
(Contains hose and hose clamps)  
06401-003-12-31

---

## SECTION 6: PARTS SECTION

### WASH MOTOR REPLACEMENT PARTS (CONTINUED)/OPERATION INSTRUCTIONS DECAL

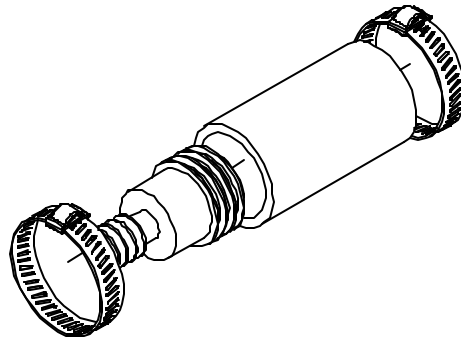

Lower Discharge Hose Replacement Kit  
(Contains the hose,barbed fitting and hose clamps)  
06401-003-12-61

---

#### OPERATING INSTRUCTIONS INITIAL FILL

1. Open door and install overflow tube into wash tank.
2. Install rinse strainer into rinse tank.
3. Install wash strainer into wash tank.
4. Place power switch in FILL position, glasswasher will fill automatically.

**NOTE:** POWER SWITCH MUST NOT BE PLACED IN ON POSITION UNTIL WASH TANK IS FULL OF WATER . RUNNING GLASSWASHER WITHOUT WATER WOULD CAUSE PUMP MOTOR TO RUN WITHOUT WATER WHICH CAN DAMAGE PUMP SEAL..

#### REQUIRED MINIMUM WASH/RINSE TEMPERATURES

5. Once wash tank is full wash temperature gauge should read no less than 130 Deg. F.
6. Place power switch to the ON position, glasswasher will now run. Rinse temperature gauge should read no less than 75 Deg. F.
7. Close door.

#### OPERATION

8. With power switch in ON position place soiled glasses on input side of conveyor.
9. After glasses have completed cycle wash, rinse and conveyor will stop.
10. Remove clean glasses from output side of conveyor, glasswasher will resume operation.

#### DRAINING AND CLEANING

11. Place power switch in OFF position and open door.
12. Remove wash strainer and clean.
13. Remove overflow, wash tank will drain.
14. Once wash tank has drained remove rinse strainer and clean.

#### DAILY CLEANING AND MAINTENANCE

15. Remove curtain, drainboards, hub cylinder and conveyor rack.
16. Remove wash and rinse arms, remove end plugs and clean with brush.
17. Clean inside of tub.
18. Clean removed components and reinstall.

Operation Instruction Decal  
09905-021-64-88

---

## SECTION 6: PARTS SECTION

### WASH & RINSE MANIFOLDS

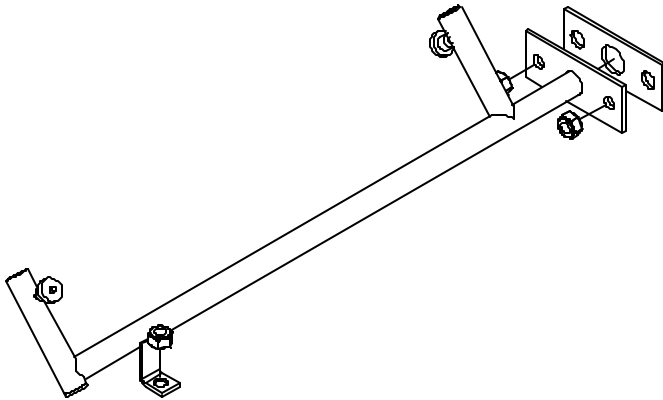

Kit, Wash Manifold Weldment Replacement  
06401-003-13-50  
(Kit contains the wash manifold weldment, gasket and mounting hardware.)

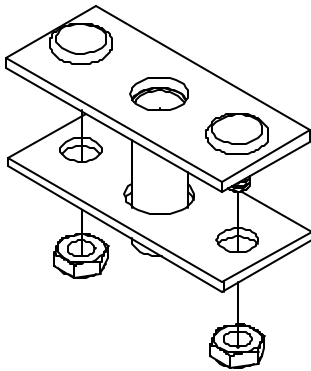

Rinse Feed Weldment Replacement Kit  
(Contains weldment, gasket & hardware)  
06401-003-12-27

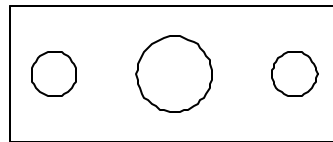

Wash/Rinse Manifold Gasket  
2 Per Unit  
05330-111-42-81

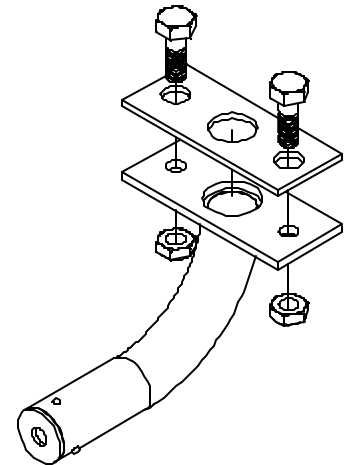

Wash Feed Weldment Replacement Kit  
(Contains weldment, gasket & hardware)  
06401-003-12-26

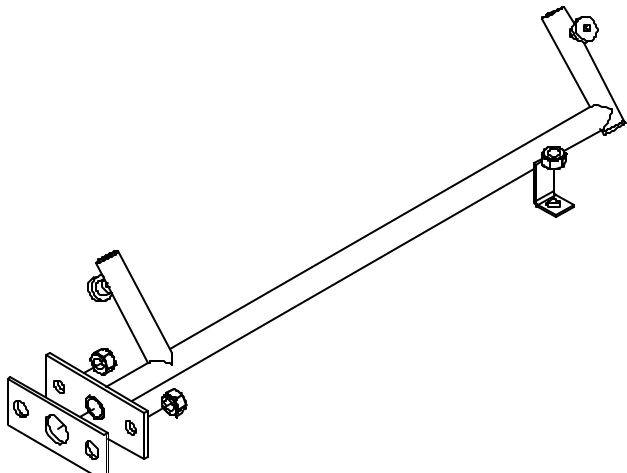

Kit, Rinse Manifold Weldment Replacement  
06401-003-13-45  
(Kit contains the rinse manifold weldment, gasket and mounting hardware.)

---

**SECTION 6: PARTS SECTION**  
**RACK WRAP REPLACEMENT KITS/FRONT SHIELD WELDEMENT**

---

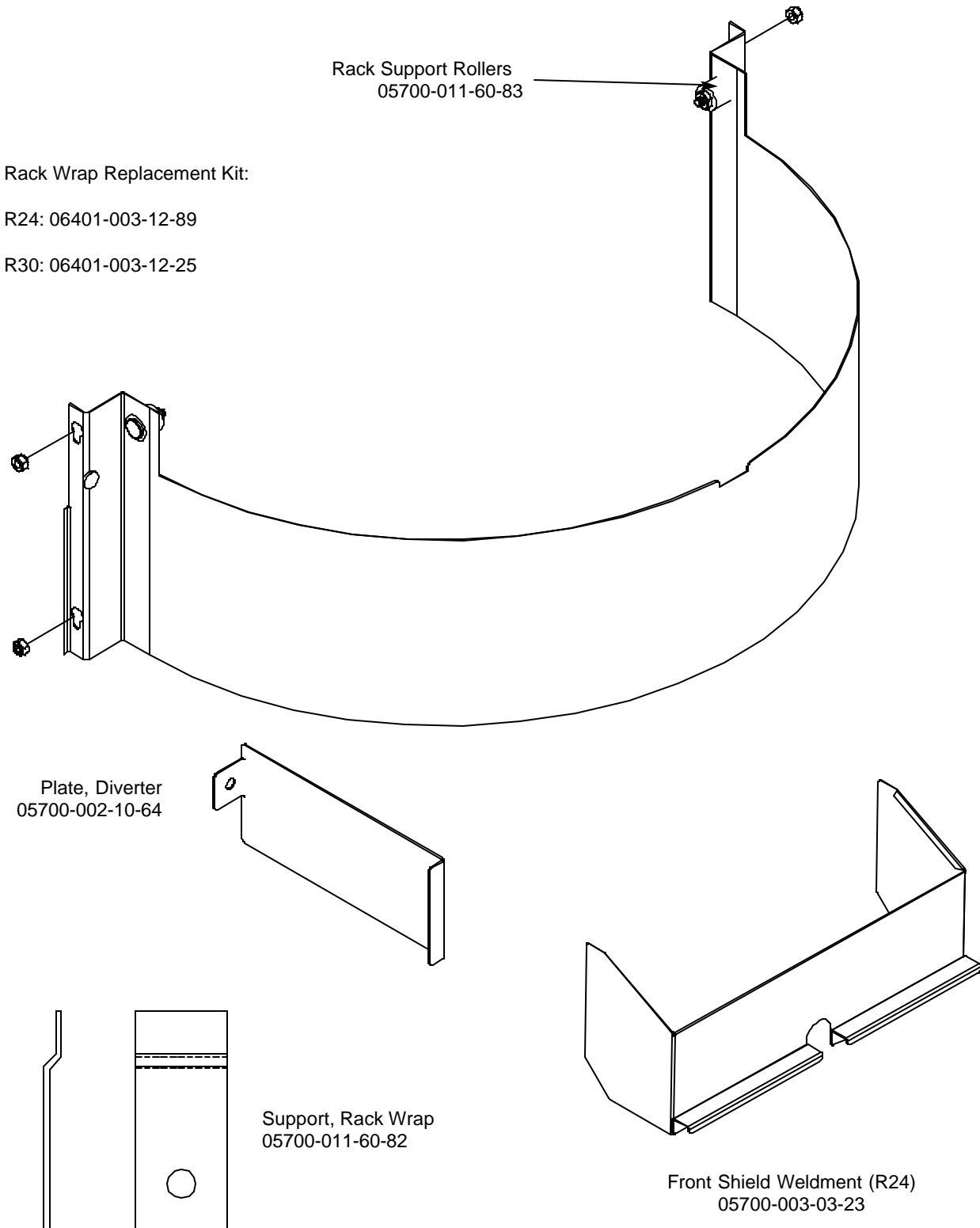



---

**SECTION 6: PARTS SECTION**  
**DRAIN BOARD ASSEMBLIES**

---

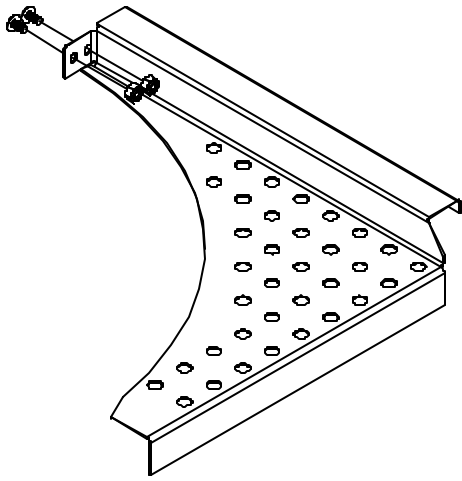

Left Drain Board Replacement Kit  
R24: 06401-003-12-90  
R30: 06401-003-12-18  
(Kit contains drain board and component mounting hardware)

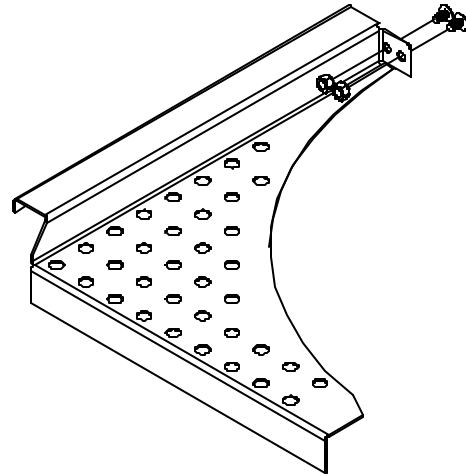

Right Drain Board Replacement Kit  
R24: 06401-003-12-91  
R30: 06401-003-12-87  
(Kit contains drain board and component mounting hardware)

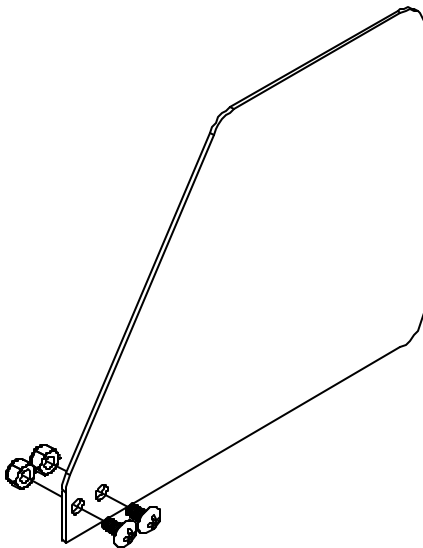

Splash Guard Replacement Kit  
06401-003-12-17  
(Kit contains splash guard and mounting hardware)

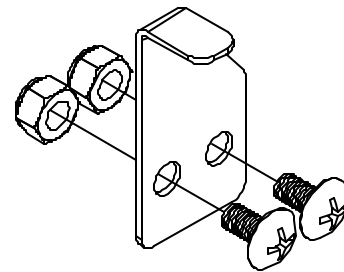

Paddle Switch Limit Replacement Kit  
06401-003-12-19  
(Kit contains paddle switch limit and mounting hardware)

## SECTION 6: PARTS SECTION

### DOOR ASSEMBLY/SWITCHES

The entire door assembly can be ordered using the following numbers:

R24: 05700-002-09-85

R30: 05700-002-00-42

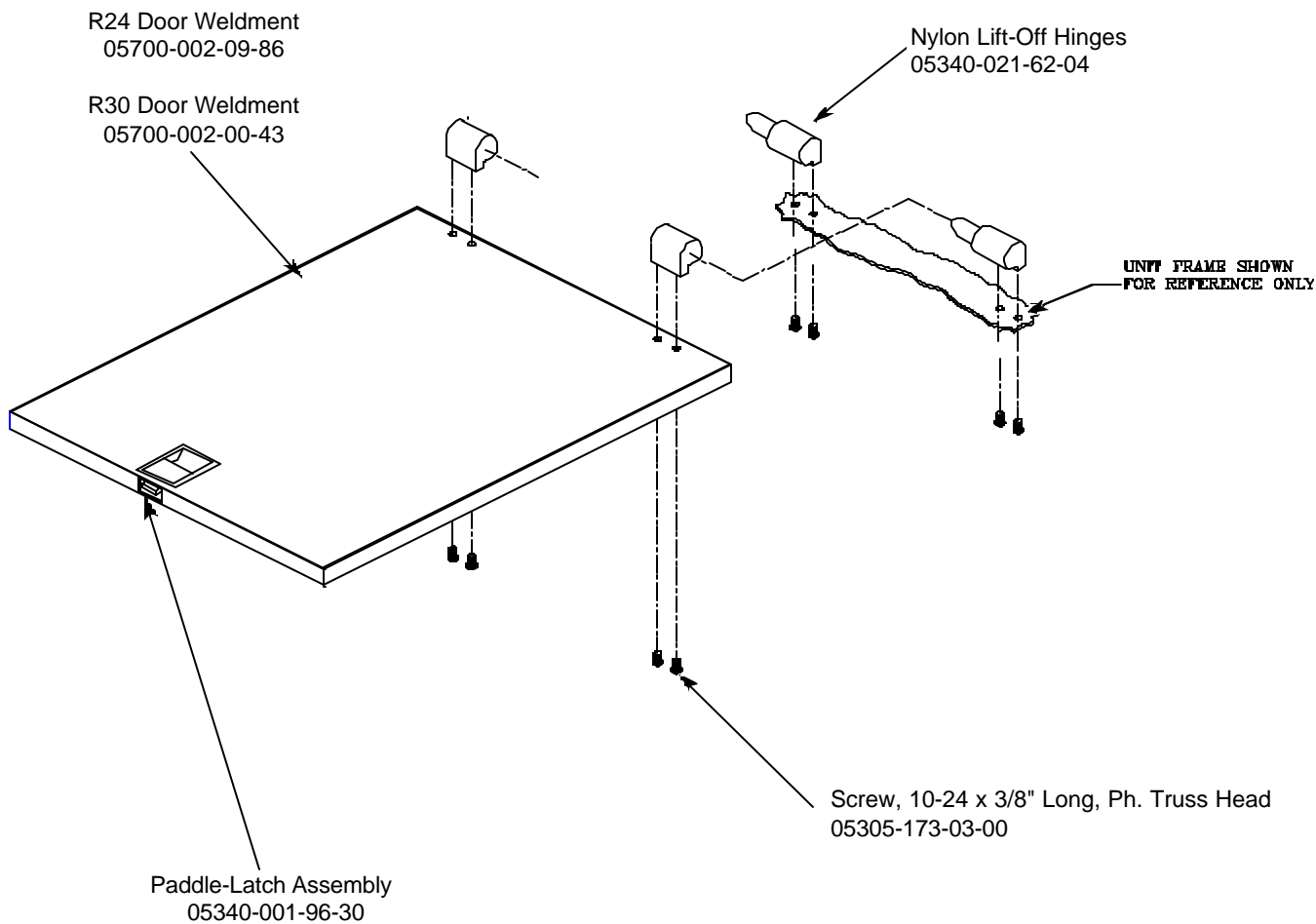

Switch, OFF/FILL/ON  
05930-011-61-69

Decal, OFF/FILL/ON  
09905-011-61-70

Liquid Tight Fitting  
05975-011-49-03

Limit Switch Cover  
05700-002-11-10

Limit Switch  
05930-011-61-65

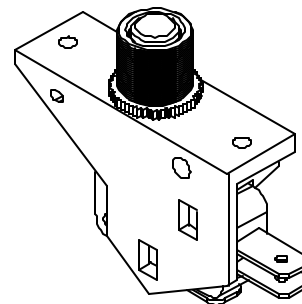
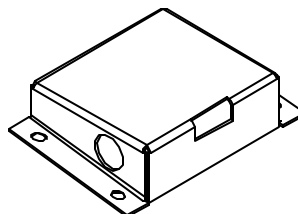
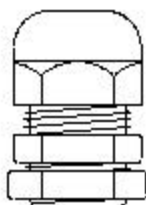
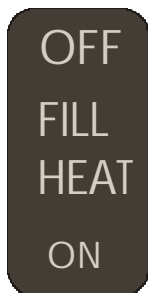
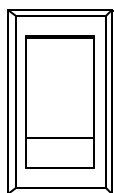

---

**SECTION 6: PARTS SECTION**  
**CURTAIN/CURTAIN ROD**

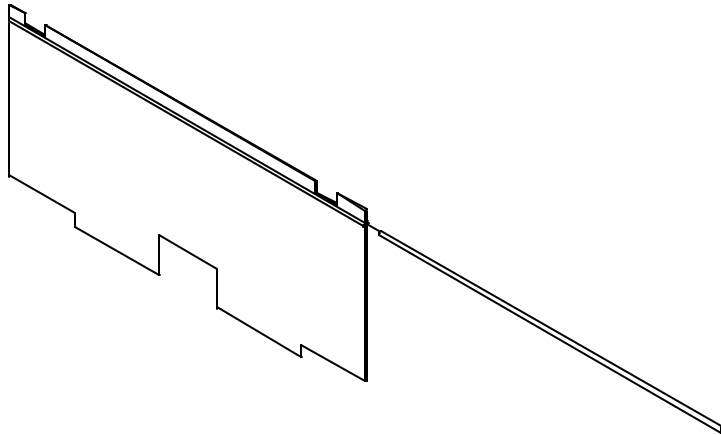

R24 Wash Curtain Replacement Kit  
06401-003-12-79

Order the Curtain Rod separately:  
05700-011-60-90

R30 Wash Curtain Replacement Kit  
06401-003-12-81

Order the Curtain Rod separately:  
05700-002-00-63

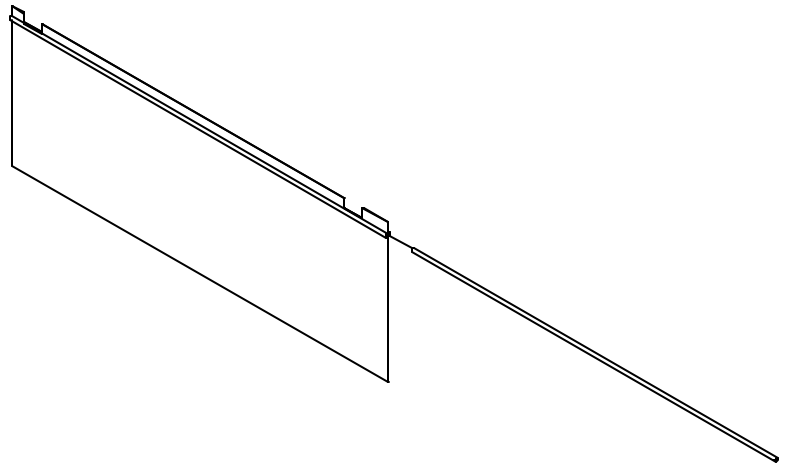

---

## SECTION 6: PARTS SECTION

### MISCELLANEOUS PARTS

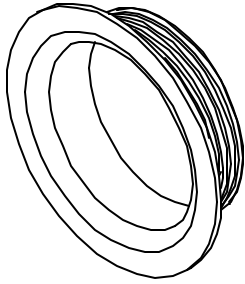

Drain, Fitting Modified  
1 per unit  
05700-002-10-24

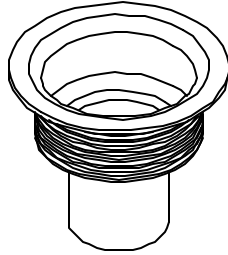

Drain, Fitting 1 per unit  
05700-002-10-61

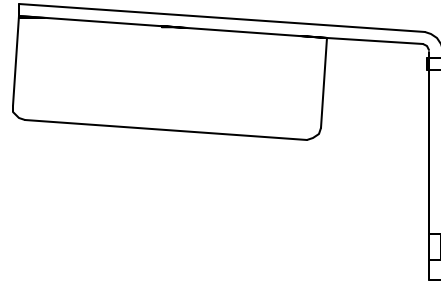

Limit Paddle Switch Assembly  
1 Per Unit  
05700-031-61-33

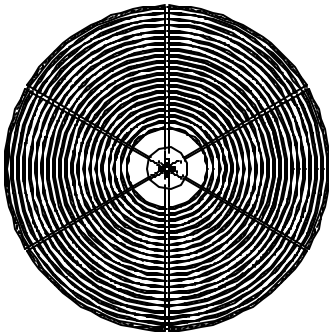

Glass Rack

R24: 05700-031-60-79

R30: 05700-031-92-11

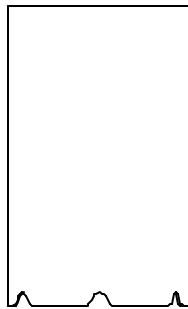

Hub Cylinder

1 per unit  
05700-002-02-99

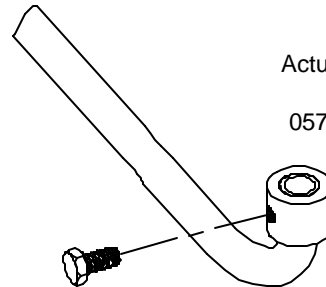

Actuator Assembly  
1 Per Unit  
05700-021-61-48

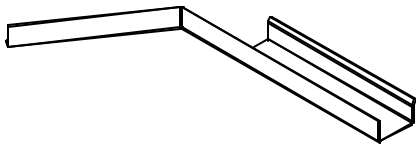

Splash Shield

R24: 05700-021-63-37

R30: 05700-002-02-51

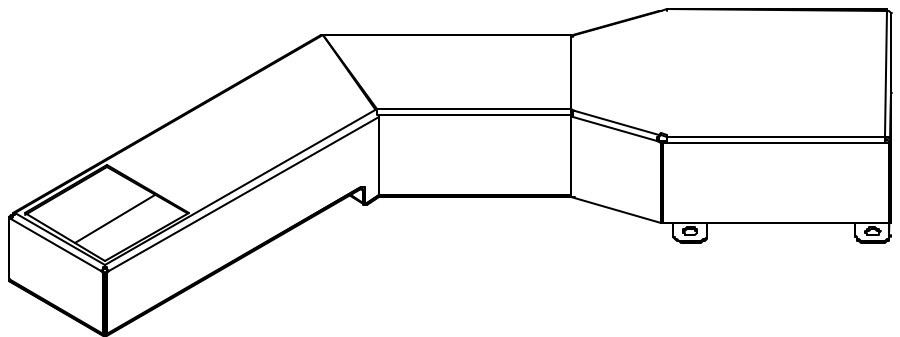

Drain Chute Replacement Kit  
(Includes drain chute, gasket and  
mounting hardware)  
1 per unit (optional)  
06401-003-12-28

Drain Chute Gasket  
1 per unit (optional)  
05330-002-15-38

---

# **SECTION 7: ELECTRICAL SCHEMATICS**

# SECTION 7: ELECTRICAL SCHEMATICS

R24 & R30 (208-230 VOLT, 60HZ, SINGLE PHASE)

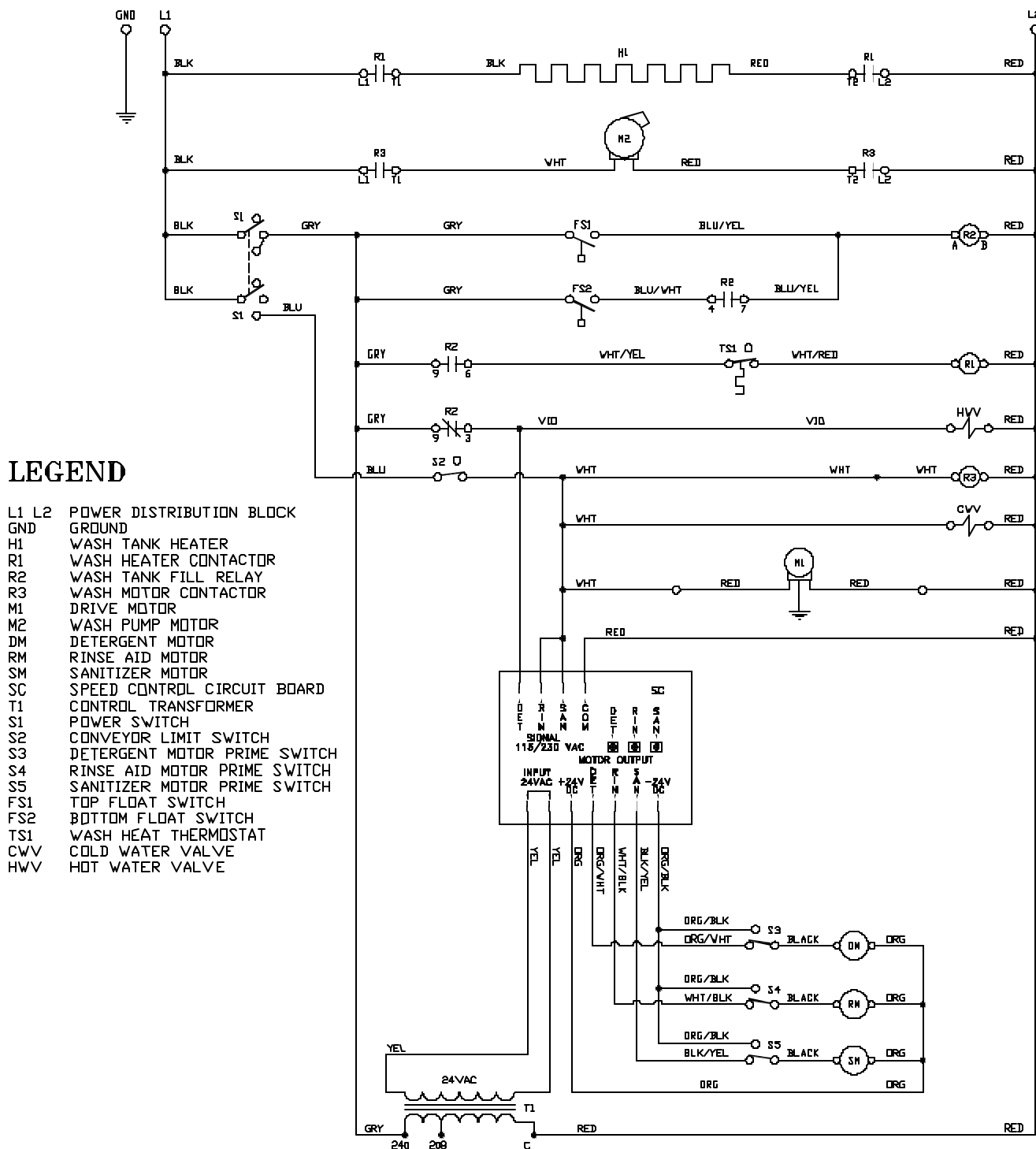

## LEGEND

- L1 L2 POWER DISTRIBUTION BLOCK
- GND GROUND
- H1 WASH TANK HEATER
- R1 WASH HEATER CONTACTOR
- R2 WASH TANK FILL RELAY
- R3 WASH MOTOR CONTACTOR
- M1 DRIVE MOTOR
- M2 WASH PUMP MOTOR
- DM DETERGENT MOTOR
- RM RINSE AID MOTOR
- SM SANITIZER MOTOR
- SC SPEED CONTROL CIRCUIT BOARD
- T1 CONTROL TRANSFORMER
- S1 POWER SWITCH
- S2 CONVEYOR LIMIT SWITCH
- S3 DETERGENT MOTOR PRIME SWITCH
- S4 RINSE AID MOTOR PRIME SWITCH
- S5 SANITIZER MOTOR PRIME SWITCH
- FS1 TOP FLOAT SWITCH
- FS2 BOTTOM FLOAT SWITCH
- TS1 WASH HEAT THERMOSTAT
- CWV COLD WATER VALVE
- HWV HOT WATER VALVE

9905-031-64-77d  
ET-1, ET-2, R-24, R-30, PA-6W

