



**Cybex® Plate Loaded Seated Calf
Owner's and Service Manual**
Strength Systems
Part Number 16210-999-4 A



**Cybex® Plate Loaded Seated Calf
Owner's and Service Manual**

Strength Systems
Part Number 16210-999-4 A

Cybex® and the Cybex logo are registered trademarks of Cybex International, Inc.

DISCLAIMER: Cybex International, Inc., makes no representations or warranties regarding the contents of this manual. We reserve the right to revise this document at any time or to make changes to the product described within it without notice or obligation to notify any person of such revisions or changes.

© Copyright 2010, Cybex International, Inc. All rights reserved.

Printed in the United States of America.

10 Trotter Drive Medway, MA 02053 • 508-533-4300 • FAX 508-533-5183

www.cybexinternational.com • techhelp@cybexintl.com • 16210-999-4 A • March 2010

Table of Contents

1 Safety	
Safety	1
Safety Guidelines and Practices	2
Warning/Caution Decals	3
Regular Maintenance Activities	4
2 Exercise	
Intended Use	4
Instructions	4
3 Customer Service	
Contacting Service	5
Ordering parts	5
Return Material Authorization (RMA)	6
Damaged Parts	6
4 Assembly	
Tools Required	7
5 Maintenance	
Daily Procedures	8
Weekly Procedures	8
6 Service	
Parts Lists	10
Exploded-View Diagram	11

1 - Safety

Safety

Read the Owner's Manual carefully before assembling, servicing or using Cybox equipment.



WARNING: Serious injury could occur if these safety precautions are not observed:

User Safety Precautions

- Obtain a medical exam before beginning any exercise program.
- Stop exercising if feeling faint, dizzy or experiencing pain and consult your physician.
- Obtain instructions before using. Lisez les instructions avant l'utilisation.
- Read and understand the owner's manual and all warnings posted on the machine before using. 
- Keep all children (12 and under) away. Teenagers (13 and over) and disabled must be supervised. Garder tous les enfants (de 12 ans et moins) éloignés. Les adolescents (de 13 ans et plus) et les handicapés doivent être surveillés.
- Use a spotter.
- Keep body and clothing free from and clear of all moving parts.
- Use the machine only for the intended use. **DO NOT** modify the machine.
- Inspect machine prior to use. **DO NOT** use if it appears damaged or inoperable.
- **DO NOT** attempt to fix a broken or jammed machine.
- Report any malfunctions, damage or repairs to the facility.
- Replace any warning labels if damaged, worn or illegible.

Facility Safety Precautions

- Read the Owner's Manual carefully before assembling, servicing or using this equipment.
 - Securely anchor machine to the floor using the anchor holes provided in each machine.
- NOTE:** Cybox is not responsible for the actual anchoring of equipment. Consult with a professional contractor.
- NOTE:** Use fasteners having a minimum of 500 lbs. tensile capacity (3/8" grade 2 bolts or better).
- NOTE:** If legs/frame does not contact surface, DO NOT pull down with anchors. Shim any leg or frame not in contact with surface using flat washers.
- Make sure that each machine is set up and operated on a solid level surface. **Do not install equipment on an uneven surface.**
 - Make sure that all users are properly trained on how to use this equipment.
 - Make sure there is enough room for safe access and operation of this equipment.
 - Perform regular maintenance checks on this equipment. Also pay close attention to all areas most susceptible to wear.

Cybox Plate Loaded 16210 Seated Calf Owner's Manual

- Immediately replace worn or damaged components. If unable to immediately replace worn or damaged components then remove from service until the repair is made.

NOTE: *It is the sole responsibility of the user/owner or facility operator to ensure that regular maintenance is performed.*

Safety Guidelines And Practices

Cybox recommends that all fitness equipment be used in a supervised area. It is recommended that the equipment be located in an access controlled area. Control is the responsibility of the owner. The extent of control is at the discretion of the owner.

It is the responsibility of the purchaser/user of Cybox products to read and understand the owner's manual, and warning labels; as well as instruct all individuals, whether end users or supervising personnel, on proper usage of the equipment.

PROPER USAGE:

Use machine only as described in the manual. Failing to follow proper instructions may result in injury.

Do Not Lean Against or Pull On the framework, weight stack, or any component, whether machine is at rest or in use. Inappropriate or improper use may result in injury to users or third parties (bystanders).

Do not use machine if it is not located on a solid level surface or is improperly installed.

Provide an adequate safety perimeter between the machine, walls and other equipment to ensure that the facility has the proper clearance for usage and training.

SECURING EQUIPMENT:

The machine has holes in the feet, which allow for ease in anchoring to the floor. Cybox strongly recommends that, to eliminate rocking, tipping or falling over due to incorrect usage and misuse, equipment be secured to a solid, level surface.

1. The solid, level surface should not deviate more than 1/8" over a 10' distance or as defined and required by local building and architectural codes.
2. Anchoring of equipment must be completed by a qualified licensed contractor.
3. Anchoring holes are provided on the feet of the frame. All anchoring locations must be used when anchoring the equipment to the floor.
4. Due to the wide variation of flooring on which machines may be anchored or installed, verify anchoring method and anchoring fasteners with a qualified and licensed contractor.
5. A minimum pull out force of 220 lbs/100 kgs is required for each anchor position..
6. Do not use machine until it is properly anchored.

MAINTENANCE:

Preventative maintenance allows proper equipment operation and reduces the risk of injury. Perform the maintenance requirements as specified in the manual.

STANDARD COMPLIANCE:

Cybox products meet or exceed applicable ASTM and EN Standards.



Warning/Caution Decals

Warning decals indicate a potentially hazardous situation, which, if not avoided, could result in death or serious injury.

Caution decals indicate a potentially hazardous situation, which, if not avoided, could result in minor or moderate injury.

The following diagram shows where each decal is located.

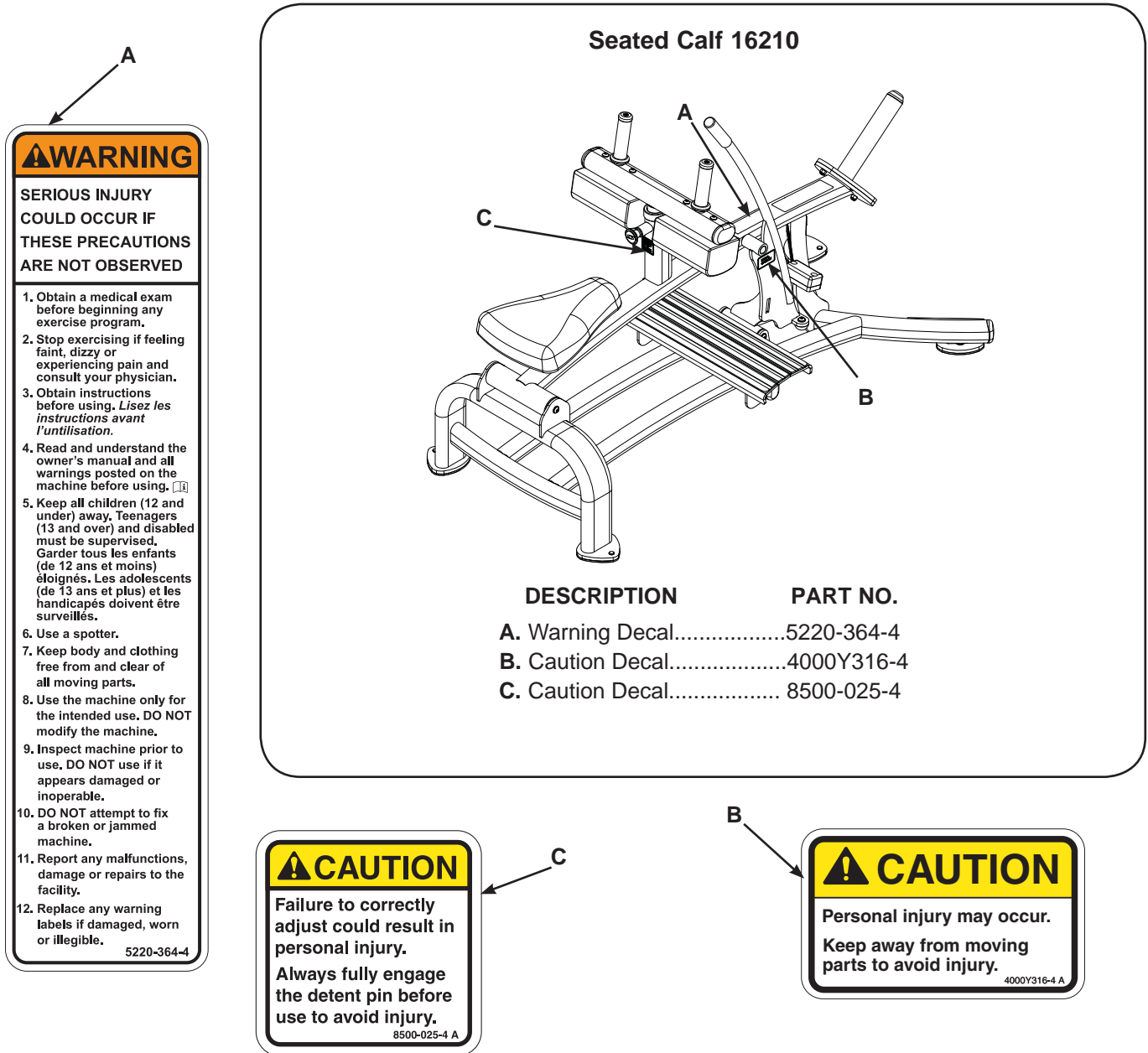

Regular Maintenance Activities

Preventative maintenance activities must be performed to maintain normal operation of this equipment. Keeping a log sheet of all maintenance actions will assist you in staying current with all preventative maintenance activities.



WARNING: Equipment found to have worn or damaged components must be removed from service until repair(s) is made. Failure to do so could result in injury.

Daily

1. Clean upholstery.

Weekly

1. Inspect all nuts and bolts for looseness. Tighten as required.
2. Check for worn handles, and worn warning labeling. Replace all worn parts immediately.

2 - Exercise

Intended Use

The intended use of this equipment is to aid or improve general physical fitness and exercise. For Commercial use.

Instructions

Read and understand all instructions and warnings prior to using this machine. See Chapter 1, Safety in Owner's Manual or consult with floor staff.

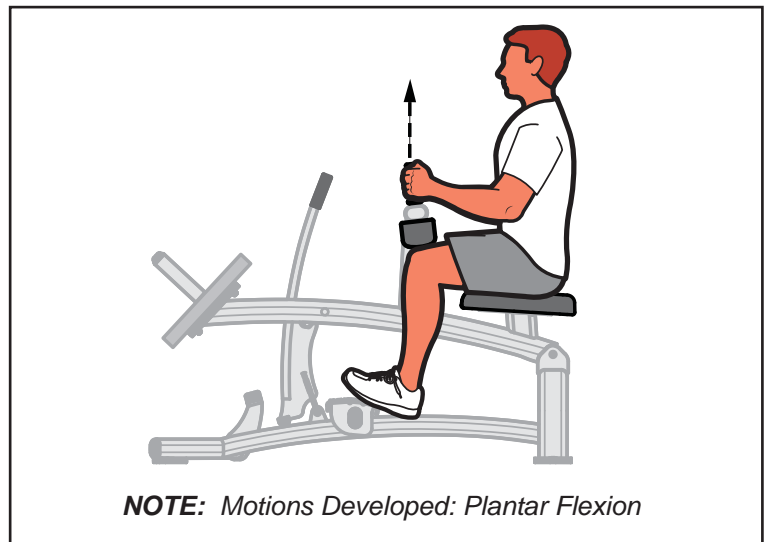
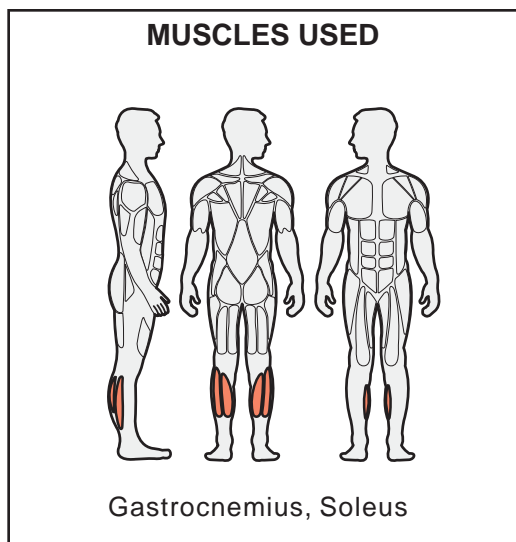

NOTE: Refer to next page for set up and movement.

Set Up

1. Load appropriate resistance.
2. With feet securely on footplates, adjust knee pads to allow comfortable positioning.

Movement

1. Push down with the balls of feet and lift your heels as high as comfortably possible.
2. When finished raise weights and pull support lever back to lock.

3 - Customer Service

Contacting Service

Hours of phone service are Monday through Friday from 8:30 a.m. to 6:00 p.m Eastern Standard Time.

For Cybox customers living in the USA, contact Cybox Customer Service at **888-462-9239**.

For Cybox customers living outside the USA, contact Cybox Customer Service at **508-533-4300** or fax **508-533-5183**.

Find information on the web at www.cyboxintl.com or e-mail at techhelp@cyboxintl.com.

Ordering Parts

Fax orders to **508-533-5183**. To speak with a customer service representative, call **888-462-9239** (for customers living within the USA) or **508-533-4300** (for customers outside the USA). You may also contact us through e-mail at techhelp@cyboxintl.com.

Having the following information ready when calling, will assist our Cybox representatives in serving you.

- **Unit Serial Number**
- **Product Name**

The unit serial number and product name can be found on the serial number decal. See Chapter 6 for exact location of serial number decal.

- **Part Description**
- **Part Number**

Part descriptions and part numbers are located in Chapter 6 of this manual.

- **Shipping Address**
- **Contact Name**

In addition to your shipping address and contact name, your account number is helpful but not required.

Return Material Authorization (RMA)

The Return Material Authorization (RMA) system outlines the procedures to follow when returning material for placement, repair or credit. The system assures that returned materials are properly handled and analyzed. Follow the following procedures carefully.

Contact your authorized Cybex dealer on all warranty-related matters. Your local Cybex dealer will request a RMA from Cybex, if applicable. Under no circumstances will defective parts or equipment be accepted by Cybex without proper RMA and an Automated Return Service (ARS) label.

1. Call the Customer Service Hot Line listed above for the return of any item that is defective.
2. Provide the technician with a detailed description of the problem you are having or the defect in the item you wish to return.
3. Provide the model and serial number of your Cybex equipment.
4. At Cybex's discretion, the technician may request that you return the problem part(s) to Cybex for evaluation and repair or replacement. The technician will assign you a RMA number and will send you an ARS label. The ARS label and the RMA numbers must be clearly displayed on the outside of the package that contains the item(s) to be returned. Include the description of the problem, the serial number of the equipment and the name and address of the owner in the package along with the part(s).
5. Forward the package through UPS to Cybex.

Attn: Customer Service Department
Cybex International, Inc.
1975 24th Ave SW
Owatonna, MN 55060

NOTE: *Merchandise returned without an RMA number on the outside of the package or shipments sent COD will not be accepted by the Cybex receiving department.*

Damaged Parts

Materials damaged in shipment should not be returned for credit. Shipping damages are the responsibility of the carrier (UPS, Federal Express, trucking companies, etc.)

Apparent Damage - Upon receipt of your shipment, check all items carefully. Any damage seen with a visual check must be noted on the freight bill and signed by the carrier's agent. Failure to do so will result in the carriers refusal to honor your damage claim. The carrier will provide you with the required forms for filing such claims.

Concealed Damage - Damage not seen with a visual check upon receipt of a shipment but notices later must be reported to the carrier as soon as possible. Upon discovery of the damage, a written or phone request to the carrier asking them to perform an inspection of the materials must be made within ten days of the delivery date. Keep all shipping containers and packing materials as they will be needed in the inspection process. The carrier will provide you with an inspection report and the necessary forms for filing a concealed damage claim. Concealed damage claim is the carrier's responsibility. Cybex, if applicable. Under no circumstances will defective parts or equipment be accepted by Cybex without proper RMA and an Automated Return Service (ARS) label.

4 - Assembly

Tools Required

- 3/4" Wrench

NOTE: It is the responsibility of the facility owner/owner of the equipment to ensure that there is appropriate clearance around each machine to allow for safe use and passage.

NOTE: Refer to chapter 6 for reference diagrams.

1. **Read and understand all instructions thoroughly before starting any of the procedures listed on this instruction sheet.**



2. **Verify you have received the appropriate configuration.**

- A. Verify that you received the correct color machine that you ordered.
- B. Verify you received the appropriate owner's manual.
- C. Verify you received the warranty sheet.

3. **Move to desired location.**

- A. Note the dimensions of the machine:
Machine Weight: 147 lbs. Size: 30 W" x 58" L x 39" H
Machine Weight: 87 kg. Size: 76 cm W x 147 cm L x 99 cm H
- B. Carefully remove shrink wrap securing rubber feet.
- C. Carefully remove each (standard) cone-shaped shipping support using a 3/4" socket or wrench.
- D. Carefully place rubber feet (supplied with machine) on each foot of the frame.

4. **Anchor machine to floor.**

- A. Securely anchor machine to the floor using the anchor holes provided in each machine.

NOTE: Cybex is not responsible for the actual anchoring of equipment. Consult with a professional contractor.

NOTE: Use fasteners having a minimum of 500 lbs. tensile capacity (3/8" grade 2 bolts or better).

NOTE: If legs/frame does not contact surface, DO NOT pull down with anchors. Shim any leg or frame not in contact with surface using flat washers.

5. **Verify proper operation.**

5 - Maintenance

All preventive maintenance activities must be performed on a regular basis. Performing routine preventive maintenance actions can aid in providing safe, trouble-free operation of all Cybox Strength Systems equipment.

NOTE: *Cybox is not responsible for performing regular inspection and maintenance actions for your machines. Instruct all personnel in equipment inspection and maintenance actions and also in accident reporting/recording. Cybox phone representatives are available to answer any questions or concerns that you may have.*

Daily Procedures

1. **Upholstery** - Wipe down all upholstery.
2. **Frames** - Wipe down all frames using a mild solution of warm water and car wash soap. Be sure to dry thoroughly. **AVOID** acid or chlorine based cleaners and also cleaners containing abrasives as these could scratch or damage the equipment.
3. **Chrome** - Clean chrome tubes, first using chrome polish and then using a car wax seal. Neutral cleaners with a pH between 5.5 and 8.5 are recommended. Be sure to dry thoroughly. **AVOID** acid or chlorine based cleaners and also cleaners containing abrasives as these could scratch or damage the equipment.

Weekly Procedures

1. Inspect all nuts and bolts for looseness. Tighten as required.
2. Inspect all labeling for readability. This includes instructional placards, warning and caution decals. Replace all worn labeling immediately.

6 - Service

Please refer to the next pages for parts lists and exploded-view diagrams

CAUTION

Use only Cybex replacement parts when servicing. Failure to do so could result in personal injury.

NOTE: All inspections and repairs must be performed by trained service personnel only.

Cybex will void warranty if non-Cybex replacement parts are used.

Plate Loaded Seated Calf

PRODUCT NO. 16210

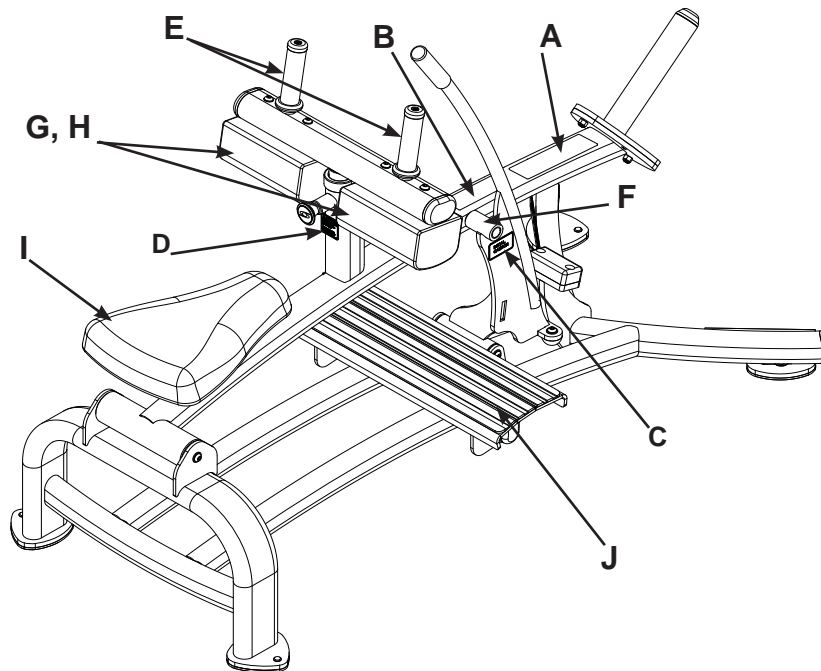

NOTE: See exploded view for location of K (serial number decal).

DESCRIPTION	PART NO.	DESCRIPTION	PART NO.
A. Placard.....	16210-598-X	F. Grip.....	16210-323
B. Warning Decal.....	5220-364-X	G. Knee Pads W/Wear Cover...	4800-071
C. Caution Decal.....	4000Y316-X	H. Wear Cover.....	4800-101
D. Caution Decal.....	8500-025-X	I. Seat Pad.....	4800-172
E. Grips.....	4605-514	J. Non Slip.....	12120-326
		K. Serial Number Decal	

Cybox Plate Loaded 16210 Seated Calf Owner's Manual

ITEM	QTY	PART NO.	DESCRIPTION
1	1	08229	P/PIN,DETENT
2	1	11040-440	KNOB
3	2	11090-374	END CAP
4	2	11090-376	RING, HANDLE GRIP
5	1	12120-326	NON-SLIP
6	4	16010-311	FOOT PAD
7	1	16060-311	PLASTIC GUIDE
8	1	16060-315	PLASTIC GUIDE
9	1	16210-200	W/ MAIN FRAME
10	1	16210-201	W/ PIVOT ARM
11	1	16210-202	W/ ADJUSTING TUBE
12	1	16210-203	W/ PIVOT ARM
13	1	16210-204	P/ WEIGHT BRACKET
14	1	16210-318	PIN, PIVOT
15	1	16210-323	VINYL GRIP
16	1	16210-329	PIVOT SHAFT
17	2	3900-445	DECAL, CYBEX BLACK
18	1	3900-446	DECAL, CYBEX SILVER
19	2	4505-331	BUMPER, 1.50 DIA
20	2	4605-514	GRAB GRIP 4.50
21	1	51198	WARRANTY BOOK (NOT SHOWN)
22	1	5220-305	2.00 X 4.00 BUMPER
23	1	630A-346	GRIP 2.50
24	2	BS070201	COM SPRING .56 x .66 1.50 LG
		FB030232	BEARING, RADIAL 17 mm
			EXTENDED RACE

***Language Key**

1-German , 2-French, 3-Spanish, 4-English, 6-Japanese,
7- Swedish, 8- Russian

ITEM	QTY	PART NO.	DESCRIPTION
25	2	FB130212	BUSHING, FLANGE .75 ID x .875 OD x .75 LG
26	2	FC030006	TOLERANCE RING 1.575 ID
27	1	HC622808	SHCS .250-20 X .250
28	1	HC700415	BHSCS .375-16 X .75
29	2	HC700416	BHSCS .375-16 X .875
30	2	HF449063	INSERT 3/4 X 1/4-20
31	2	HM583208	10-32 X .25 LG
32	2	HN704901	LOCKNUT, .375-16 NYLON
33	2	HP286810	SPRING PIN .188 X .37 LG
34	5	HS347600	WASHER, SAE .375
35	2	JC620422	BHSCS .250-20 x 1.50
36	4	JC700412	BHSCS .375-16 X .50
37	2	JC700420	BHSCS .375-16 X 1.25
38	4	JC700434	BHSCS .375-16 X 3.00
39	2	JC700920	FHSCS .375-16 X 1.25
40	6	JS347400	LOCKWASHER, INT TOOTH .375
41	4	PP130003	INSERT, DOMED PLASTIC
42	1	PP130006	INSERT, PLASTIC END
43	2	PP130007	INSERT, DOMED PLASTIC
44	1	4800-172	SEAT PAD
45	2	4800-071	KNEE PAD W/WEAR COVER
46	2	4800-101	WEAR COVER
47	1	16210-598-X*	PLACARD
48	1	5220-364-X*	DECAL, WARNING
49	1	8500-025-X*	DECAL CAUTION
50	1	4000Y316-X*	DECAL CAUTION
51	1	11040-790	DECAL, MADE IN USA

16210 SEATED CALF MAIN ASSEMBLY DETAIL

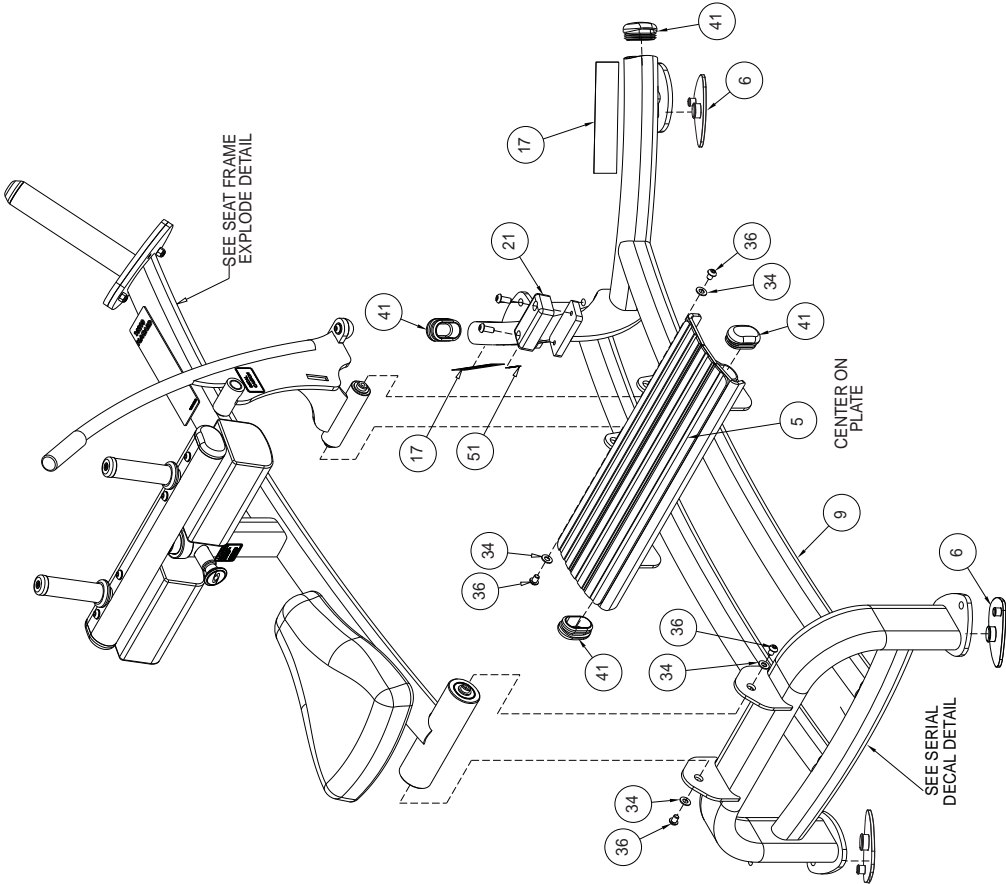
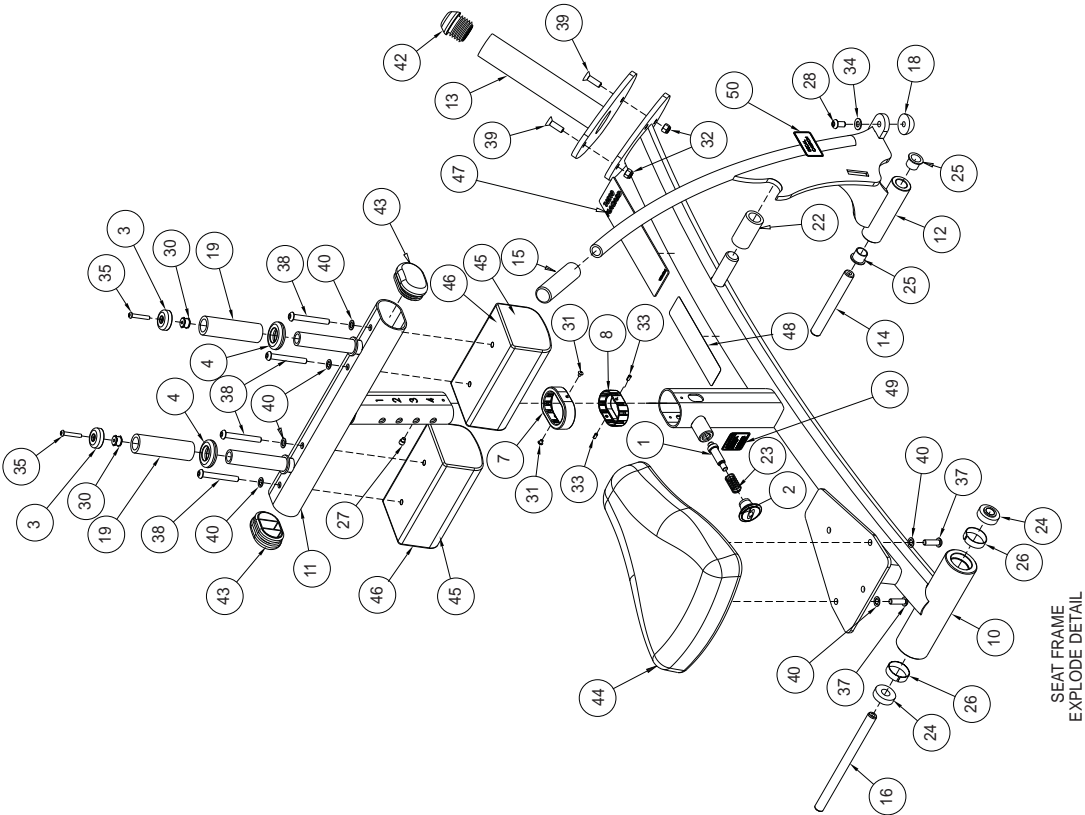

16210 SEATED CALF DECAL PLACEMENT DETAIL

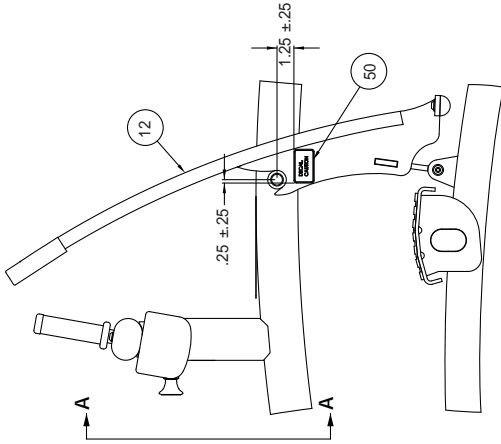
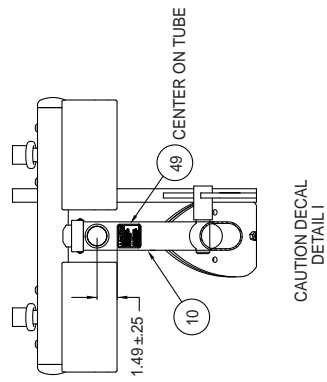

CAUTION DECAL DETAIL II

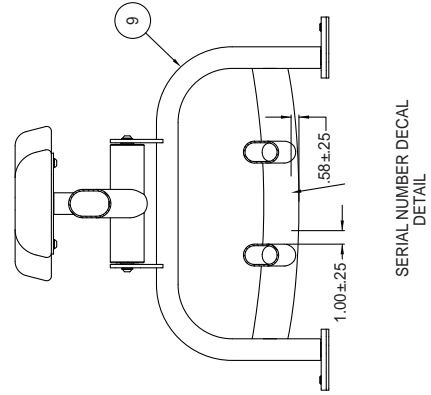
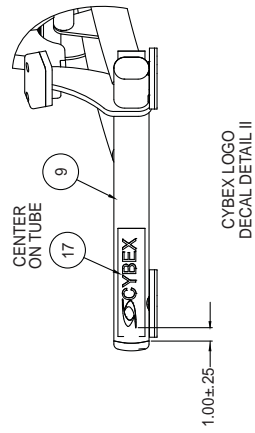
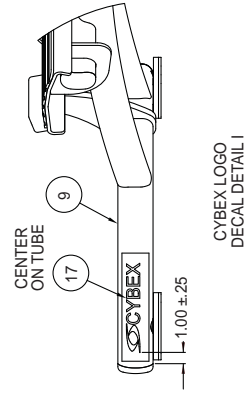
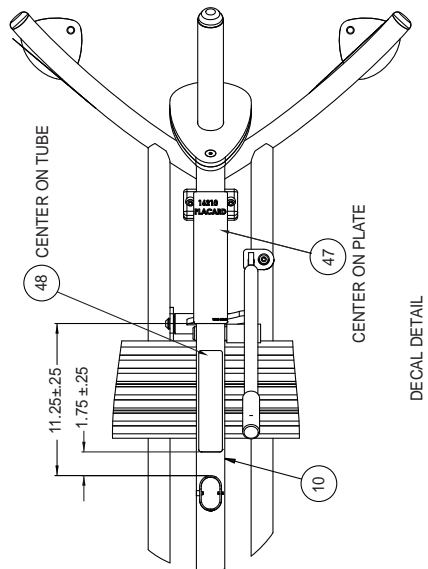



10 Trotter Drive Medway, MA 02053 • 508-533-4300 • FAX 508-533-5183
www.cybexinternational.com • techhelp@cybexintl.com