

Service
Service
Service



Philips Consumer Lifestyle

Service Manual

PRODUCT INFORMATION

Features

Iron

- SteamGlide Soleplate
- Continuous steam in horizontal & vertical position
- Adjustable steam rate up to 120 g/min
- Steam activator lock
- Steam tip for hard-to-reach places
- Steam hose length : 1.7 m

Stand

- Anti-corrosion Inox boiler
- Boiler sensing : Electronic
- Boiler pressure : 5.0 bar
- Fast heat-up : steam ready in 2 mins.
- Cord length : 2.5 m
- Hose cord storage
- Easy to rinse
- Detachable tank : 1.4 L

Safety Information

- This product meets the requirements regarding interference suppression on radio and TV.
- After the product has been repaired, it should function properly and has to meet the safety requirements as officially laid down at this moment.

TECHNICAL INFORMATION

Voltage	:	220 - 240 V
Frequency	:	50 - 60 Hz
Power Iron	:	800 W
Boiler	:	1370 W
Dimension (F-box)	:	350 x 350 x 250 mm (L x W x H)
Weight (with packing)	:	6.4 kg

Water advice

If the tap water in your area is very hard, it is advisable to mix the tap water with an equal amount of demineralised water.

SteamGlide Soleplate

Scratch resistant, non-stick, easy to clean & very durable.

Fast ironing

Steam ready in 2 minutes & up to 5 bar of steam pressure penetrating deeper into the fabrics.

Easy to rinse

The new design of the rinse cap makes it very easy to rinse the boiler regularly. Simply unscrew the cap and pour out the "dirty" water into the sink.

No hassle with coins, extra tubes or anything of this sort.

Large detachable water tank

1.4 Liter water tank allows up to 3 hours freedom of ironing without refilling.

BACKPLATE 18

HOSE CORD ASSY 19

- Remove Screw A
- Disassemble BACKPLATE 18
- Remove Screw B1, B2
- Remove Clamping plate
- Remove Power cord quick-connect S, E, L, N
- Remove Hose clip (a)
- Disassemble Steam hose
- Disassemble HOSE CORD ASSY 19

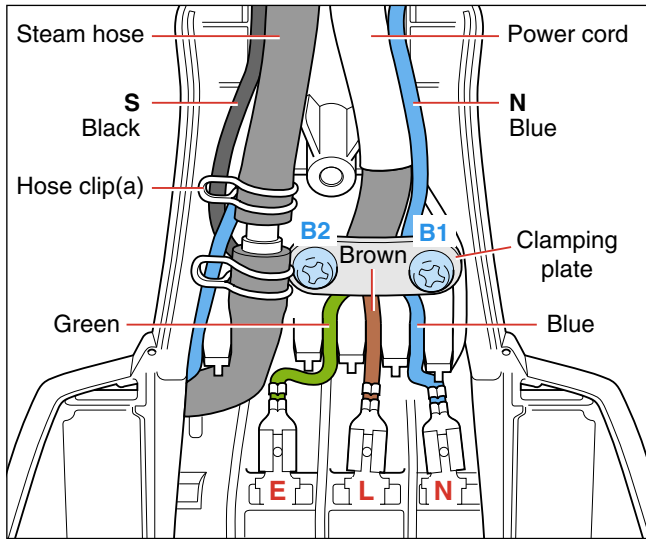

Fig 1. Wiring at rear HOUSING (Part 1)

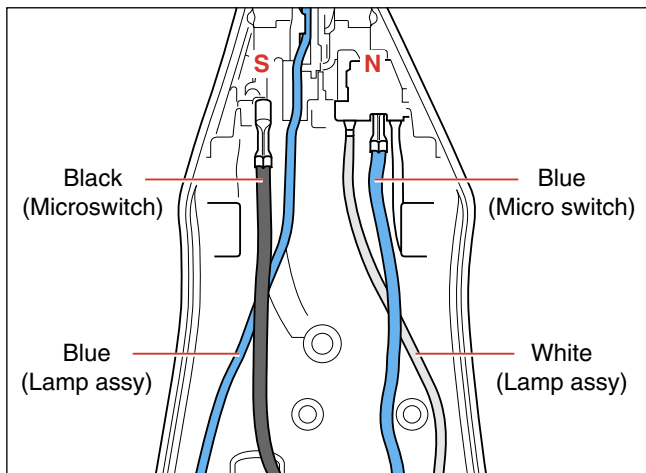

Fig 2. Wiring at rear HOUSING (Part 2)

INLAY 17

STEAM LOCK 13

LAMP ASSY 8

MICROSWITCH ASSY 11

TRIGGER 12

THERMOSTAT DIAL ASSY 15

HOUSING PRINTED 10

SOLEPLATE COVER 6

THERMOSTAT BUSH 9

BRAIDED RUBBER HOSE 3

SOLEPLATE ASSY 1

- Remove Screw A
- Disassemble BACKPLATE 18
- Release Inlay rear catch
- Disassemble INLAY 17
- Disassemble STEAM LOCK 13
- Disassemble MICROSWITCH ASSY 11
- Remove Screw C
- Disassemble TRIGGER 12
- Disassemble THERMOSTAT DIAL 15

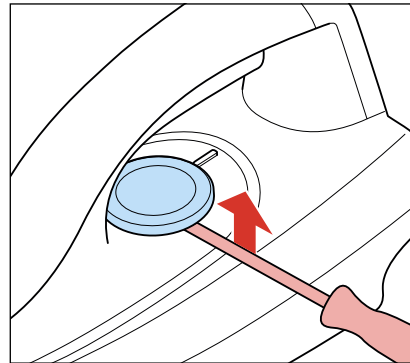

Fig 3.

- Remove Screws D1, D2, D3
- Disassemble HOUSING PRINTED 10
- Remove Screws E1, E2, E3
- Disassemble SOLEPLATE COVER 6
- Remove HOSE CLIP 4
- Disassemble BRAIDED RUBBER HOSE 3

Pos	Service code	Description
1	4239 021 41291	Soleplate assy 230 V (Steamglide-Non SOS)
3	4239 015 59301	Braided rubber hose (Basic)
4	4239 010 10281	Hose clip-braided rubber hose
5	4239 015 70150	Ryton ring
6	4239 026 46591	Soleplate cover
8	4239 021 36861	Lamp mounted assy
9	4239 026 13220	Thermostat bush
10	4239 021 65042	Housing printed
11	4239 021 31790	Microswitch assy
12	4239 026 46601	Trigger (Dark blue)
13	4239 026 46611	Steam lock (Dark Blue)
14	4239 010 09290	Trigger spring
15	4239 021 61321	Thermostat dial assy (Blue)
17	4239 026 46621	Inlay (Dark blue)
18	4239 026 21895	Backplate (White)
19	4239 021 65051	Hose cord mounted assy

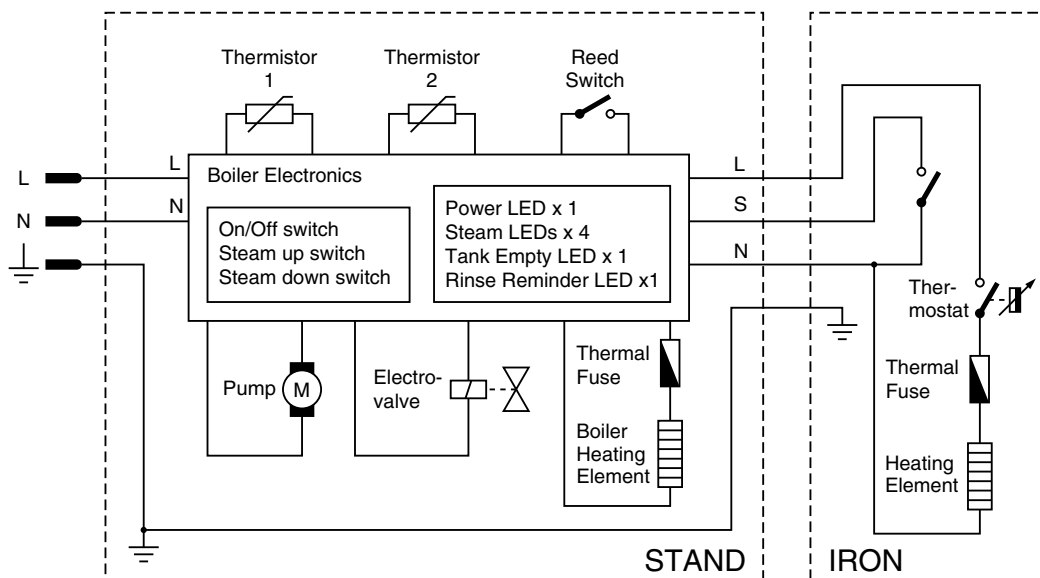
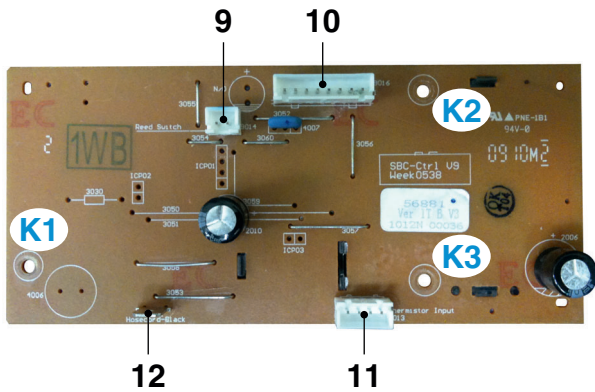

Fig 4 . Electrical diagram

- TRAY RUBBER CAP 37
- BMC TRAY 36
- STAND TOP 24
- FRONT PANEL PRINTED 31
- BOILER ASSY EE 20
- ELECTROVALVE 21
- POWER BOARD 35
- CONTROL BOARD 41
- PUMP ASSY 27
- RINSE RUBBER COUPLING 38
- RINSE BUSH 39
- SAFETY CAP ASSY 29
- REED SWITCH ASSY 33

- Remove WATER TANK ASSY 42
- Remove TRAY RUBBER CAP 37 (3x)
- Remove Screws F1, F2, F3
- Disassemble BMC TRAY 36
- Remove Screws G1, G2, G3, G4
- Remove SAFETY CAP ASSY 29
- Remove RINSE BUSH 39
- Remove RINSE RUBBER COUPLING 38
- Disassemble STAND TOP 24
- Remove Screws H1, H2
- Disassemble BOILER ASSY 20
- Remove Screws J1, J2
- Disassemble FRONT PANEL PRINTED 31



Pos.	Connected to	Pos.	Connected to
9	Reed switch	11	Thermistor
10	Power board	12	Hosecord (Black)

Fig 5. Connections on CONTROL BOARD 41

- Remove Connections 9, 10, 11, 12 (Fig 5)
- Remove Screws at K1, K2, K3 (Fig 5)
- Disassemble CONTROL BOARD 41

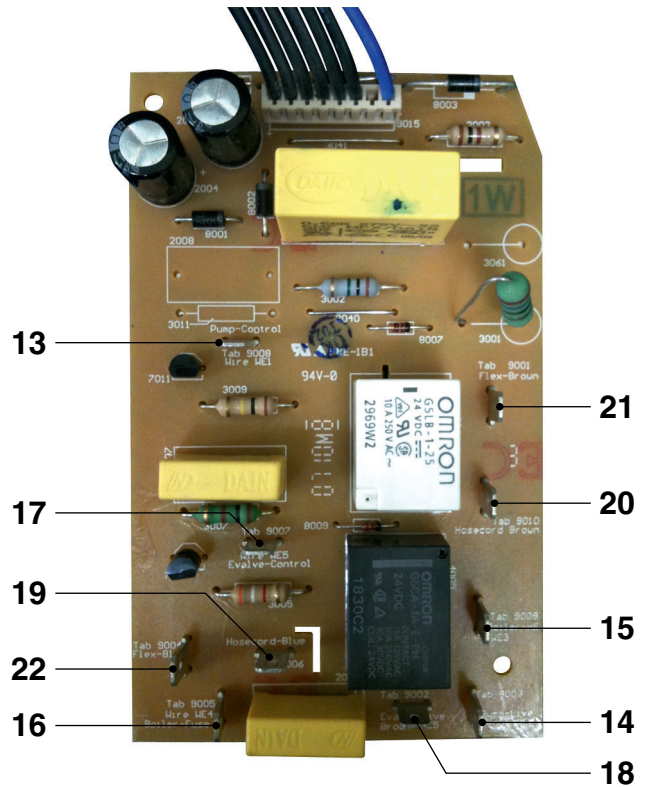

Pos.	Connected to	Pos.	Connected to
13	Pump-Control	18	Electrovalve-Live
14	Pump-Live (Brown)	19	Hosecord (Blue)
15	Boiler-Heating Element	20	Hosecord (Brown)
16	Boiler-Fuse	21	Cordset (Brown)
17	Electrovalve-Control	22	Cordset (Blue)

Fig 6. Connections on POWER BOARD 35

WATER TANK ASSY 42

Pos	Service code	Description
20	4239 021 61051	Boiler assy EE
21	4239 017 09892	Electrovalve
22	4239 010 11111	Electrovalve mesh
23	4239 021 62031	Stand bottom EE (Tulip Blue)
24	4239 021 62181	Stand top assy (White)
25	4239 026 26113	Spacer bottom
26	4239 026 26123	Spacer top
27	4239 021 62461	Pump assy
28	4239 010 10260	Inox clamp
29	4239 022 62500	Safety cap assy
30	4239 026 21930	Nipple plate
31	4239 021 61161	Front panel printed
32	4239 015 59121	Power button cap (Blue)

Pos	Service code	Description
33	4239 021 31820	Reed switch assy
34	4239 015 56160	Braided rubber hose
35	4239 021 31970	Power board
36	4239 026 42351	BMC tray (Dark blue)
37	4239 015 59111	Tray rubber cap front
38	4239 015 56050	Rinse rubber coupling
39	4239 026 22330	Rinse bush
40	4239 000 11351	Cordset EU
41	4239 021 56881	Control board
42	4239 021 61341	Water tank assy (Blue)
43	4239 015 58201	O-ring
44	4239 026 42081	De air valve

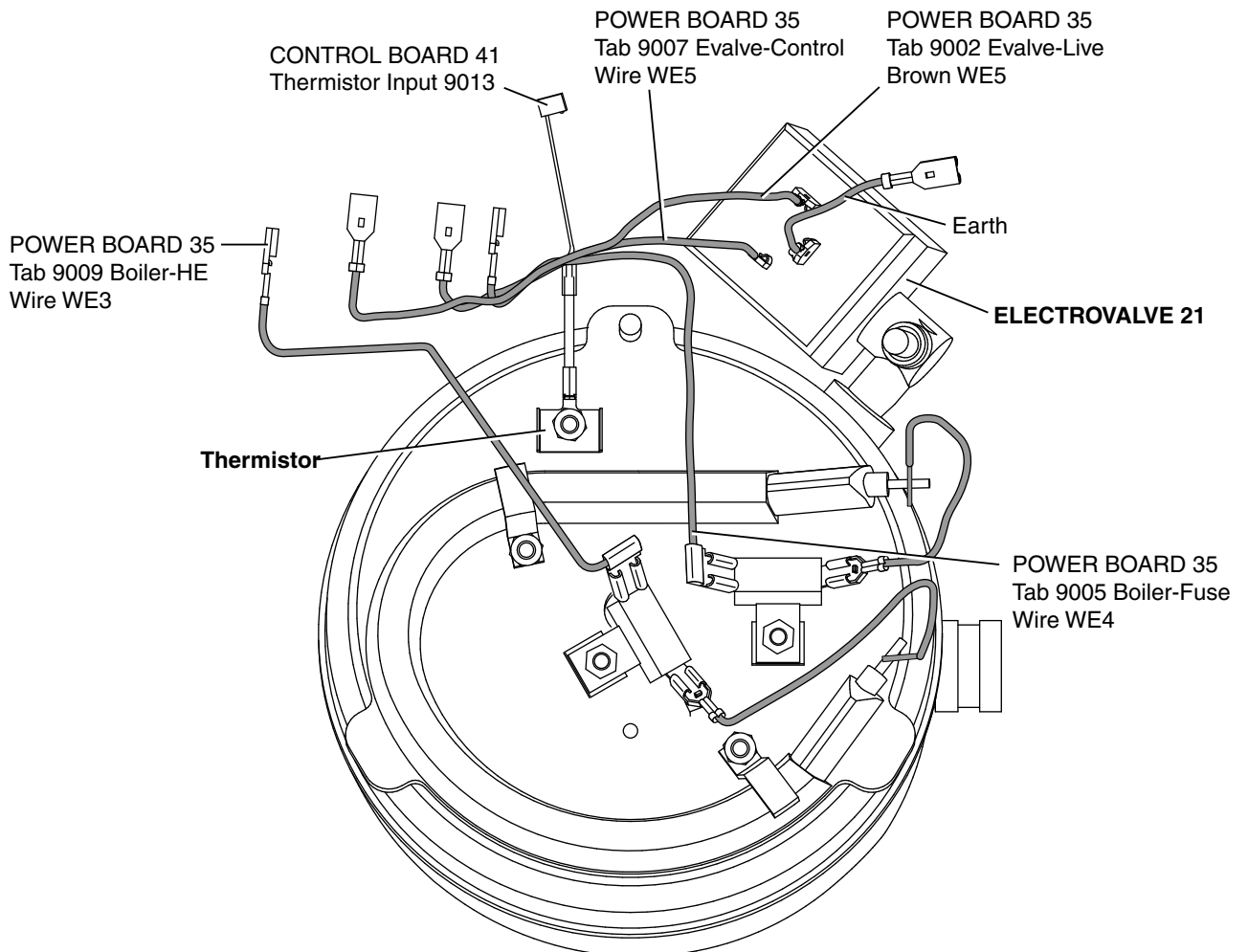
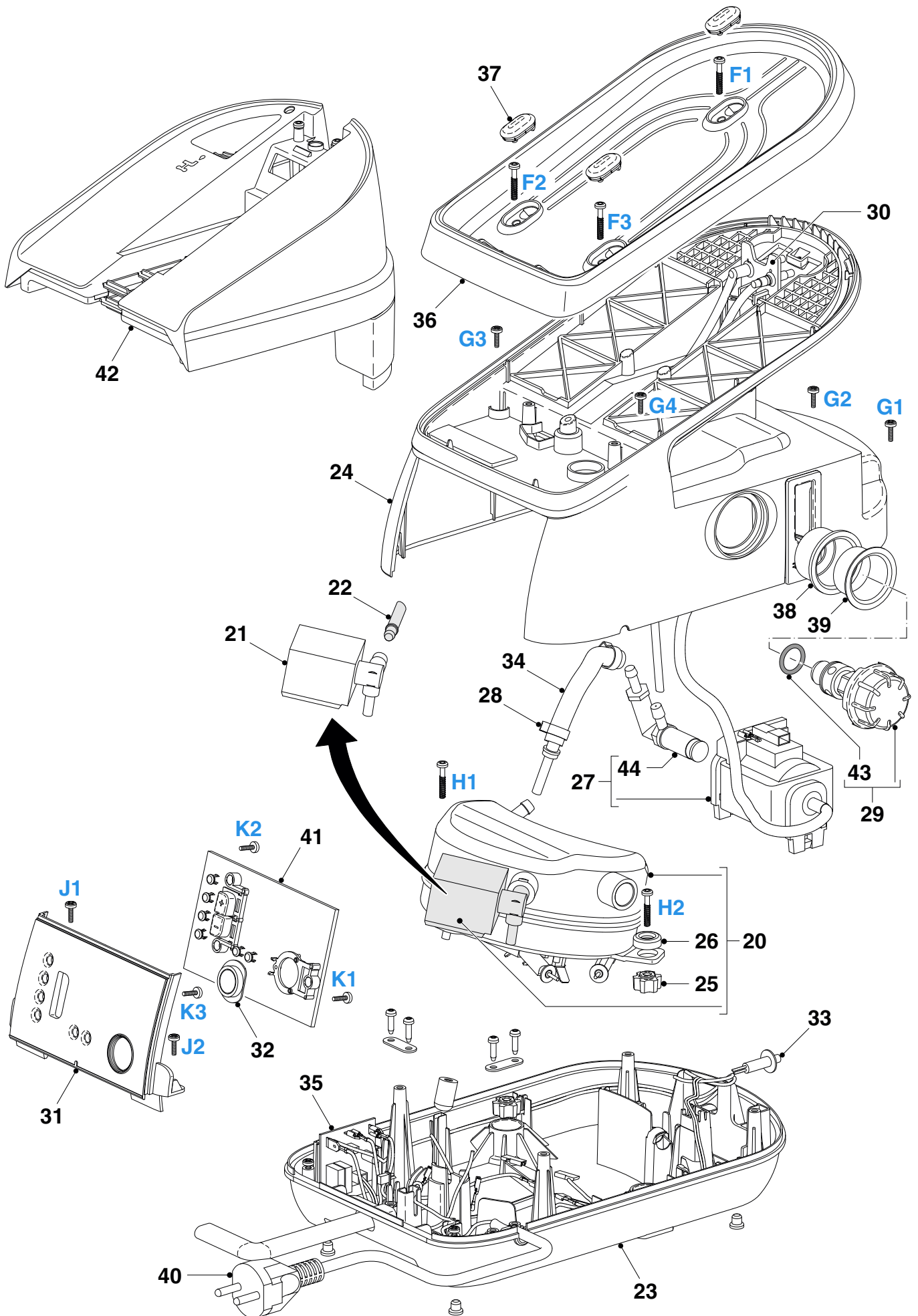

Fig 7. Boiler assy - Wiring Diagram



- Due to the high wattage of the iron, only the specified cord set must be used.
- Should damage be observed on the **HOSE-CORD ASSY 19** or **CORDSET 40**, they must be replaced. Continued usage is not allowed.
- When replacing the **MICROSWITCH ASSY 11**, please dress the 2 attached wires such that they are free of tension. Pulling force on the wires may affect the steam triggering.
- To avoid damage to the sealing & components of the **BOILER ASSY 20**, **NEVER** clean the boiler assy with vinegar, descaling agent or other corrosive chemicals.
- When replacing **ELECTROVALVE 21** or **PUMP ASSY 27**, please be reminded to apply loctite at the joints for good sealing.
- After the product has been repaired, it should function properly and has to meet the safety requirements & legal regulations as laid down & officially established at this moment.
- The following tests are common checks that are conducted on a repaired product before it is returned to the consumer.

1. Soleplate temperature

Check that soleplate temperature is within IEC requirement.

Measure the temperature of the soleplate after the iron has reached steady state i.e connected to the mains for at least 15 minutes. The table below shows the temperature requirement.

Marking	Soleplate temperature (Deg C)			Material, for example
	Minimum	Maximum	Nominal + Tolerance	
• (1 dot)	70	120	95 ± 25	Acetate, elastane, polyamide, polyproylene
•• (2 dots)	100	160	130 ± 30	Cupro, polyester, silk, triacetate, viscose, wool
••• (3 dots)	140	210	175 ± 35	Cotton, linen

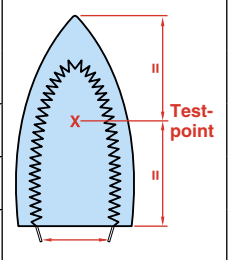

2. Leakage current

Check that leakage current is within IEC requirement.

Measure leakage current between LIVE/NEUTRAL & EARTH.

IEC requirement is that at 230 V supply, the EARTH leakage current must be less than 0.75 mA.

3. Water leakage / Functionality

Check that there is no water leakage from any part of the product during operation.

Check that the functionality of the product (product dependent) eg. steaming, variable steam, SOS, ASO etc is working properly.

4. Loose part

Check that there are no loose parts eg. extra screw in the product that can cause short-circuit or product malfunction.