

# Service Manual

Digital Camera

**LUMIX**  
LEICA  
DC VARIO-ELMARIT



**DMC-FZ50PP**  
**DMC-FZ50PL**  
**DMC-FZ50EB**  
**DMC-FZ50EE**  
**DMC-FZ50EF**  
**DMC-FZ50EG**  
**DMC-FZ50EGM**  
**DMC-FZ50GC**  
**DMC-FZ50GD**  
**DMC-FZ50GK**  
**DMC-FZ50GN**  
**DMC-FZ50GT**  
**DMC-FZ50SG**

Vol. 1

Colour

(S).....Silver Type

(K).....Black Type

**⚠ WARNING**

This service information is designed for experienced repair technicians only and is not designed for use by the general public. It does not contain warnings or cautions to advise non-technical individuals of potential dangers in attempting to service a product. Products powered by electricity should be serviced or repaired only by experienced professional technicians. Any attempt to service or repair the product or products dealt with in this service information by anyone else could result in serious injury or death.

**Panasonic®**

© 2006 Matsushita Electric Industrial Co., Ltd. All rights reserved. Unauthorized copying and distribution is a violation of law.

# TABLE OF CONTENTS

	PAGE
<b>1 Safety Precaution</b> .....	<b>3</b>
1.1. General Guidelines .....	3
1.2. Leakage Current Cold Check .....	3
1.3. Leakage Current Hot Check (See Figure 1.) .....	3
1.4. How to Discharge the Capacitor on Flash PCB .....	4
<b>2 Warning</b> .....	<b>5</b>
2.1. Prevention of Electro Static Discharge (ESD) to Electrostatically Sensitive (ES) Devices .....	5
2.2. How to Recycle the Lithium Ion Battery (U.S. Only) .....	5
2.3. Caution for AC Cord (For EB/GC/SG) .....	6
2.4. How to Replace the Lithium Battery .....	7
<b>3 Service Navigation</b> .....	<b>9</b>
3.1. Introduction .....	9
3.2. General Description About Lead Free Solder (PbF) .....	9
3.3. Important Notice 1: (Other than U.S.A. and Canadian Market) .....	9
3.4. How to Define the Model Suffix (NTSC or PAL model) .....	10
<b>4 Specifications</b> .....	<b>12</b>
<b>5 Location of Controls and Components</b> .....	<b>13</b>
<b>6 Service Mode</b> .....	<b>14</b>
6.1. Error Code Memory Function .....	14
6.2. Confirmation of Firmware Version .....	17
<b>7 Service Fixture &amp; Tools</b> .....	<b>18</b>
7.1. Service Fixture and Tools .....	18
7.2. When Replacing the Main PCB .....	19
7.3. Service Position .....	19
<b>8 Disassembly and Assembly Instructions</b> .....	<b>21</b>
8.1. Disassembly Flow Chart .....	21
8.2. PCB Location .....	21
8.3. Disassembly Procedure .....	22
8.4. Disassembly Procedure for the Lens .....	32
8.5. Assembly Procedure for the Lens .....	36
8.6. Removal of the CCD .....	42
<b>9 Measurements and Adjustments</b> .....	<b>43</b>
9.1. Adjustment Procedures .....	43
<b>10 Maintenance</b> .....	<b>44</b>
10.1. Cleaning Lens, Viewfinder and LCD Panel .....	44

PAGE

# 1 Safety Precaution

## 1.1. General Guidelines

### 1. IMPORTANT SAFETY NOTICE

There are special components used in this equipment which are important for safety. These parts are marked by

 in the Schematic Diagrams, Circuit Board Layout, Exploded Views and Replacement Parts List. It is essential that these critical parts should be replaced with manufacturer's specified parts to prevent X-RADIATION, shock, fire, or other hazards. Do not modify the original design without permission of manufacturer.

2. An Isolation Transformer should always be used during the servicing of AC Adaptor whose chassis is not isolated from the AC power line. Use a transformer of adequate power rating as this protects the technician from accidents resulting in personal injury from electrical shocks. It will also protect AC Adaptor from being damaged by accidental shorting that may occur during servicing.
3. When servicing, observe the original lead dress. If a short circuit is found, replace all parts which have been overheated or damaged by the short circuit.
4. After servicing, see to it that all the protective devices such as insulation barriers, insulation papers shields are properly installed.
5. After servicing, make the following leakage current checks to prevent the customer from being exposed to shock hazards.

## 1.2. Leakage Current Cold Check

1. Unplug the AC cord and connect a jumper between the two prongs on the plug.
2. Measure the resistance value, with an ohmmeter, between the jumpered AC plug and each exposed metallic cabinet part on the equipment such as screwheads, connectors, control shafts, etc. When the exposed metallic part has a return path to the chassis, the reading should be between  $1\text{ M}\Omega$  and  $5.2\text{ M}\Omega$ . When the exposed metal does not have a return path to the chassis, the reading must be infinity.

## 1.3. Leakage Current Hot Check (See Figure 1.)

1. Plug the AC cord directly into the AC outlet. Do not use an isolation transformer for this check.
2. Connect a  $1.5\text{ k}\Omega$ ,  $10\text{ W}$  resistor, in parallel with a  $0.15\text{ }\mu\text{F}$  capacitor, between each exposed metallic part on the set and a good earth ground, as shown in Figure 1.
3. Use an AC voltmeter, with  $1\text{ k}\Omega/\text{V}$  or more sensitivity, to measure the potential across the resistor.
4. Check each exposed metallic part, and measure the voltage at each point.
5. Reverse the AC plug in the AC outlet and repeat each of the above measurements.
6. The potential at any point should not exceed  $0.75\text{ V RMS}$ . A leakage current tester (Simpson Model 229 or equivalent) may be used to make the hot checks, leakage current must not exceed  $1/2\text{ mA}$ . In case a measurement is outside of the limits specified, there is a possibility of a shock hazard, and the equipment should be repaired and rechecked before it is returned to the customer.

Hot-Check Circuit

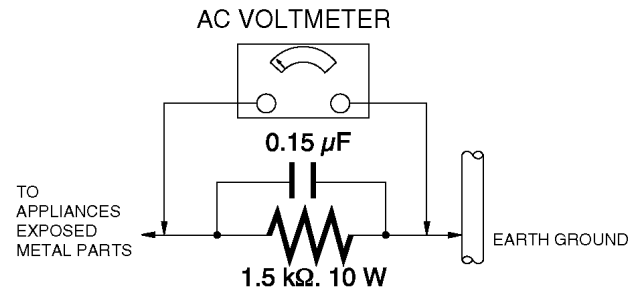

Figure. 1

## 1.4. How to Discharge the Capacitor on Flash PCB

### CAUTION:

1. Be sure to discharge the capacitor on FLASH PCB.
2. Be careful of the high voltage circuit on FLASH PCB when servicing.

### [Discharging Procedure]

1. Refer to the disassemble procedure and Remove the necessary parts/unit.
2. Put the insulation tube onto the lead part of Resistor (ERG5SJ102:1k $\Omega$  /5W).  
(an equivalent type of resistor may be used.)
3. Put the resistor between both terminals of capacitor on FLASH PCB for approx. 5 seconds.
4. After discharging confirm that the capacitor voltage is lower than 10V using a voltmeter.

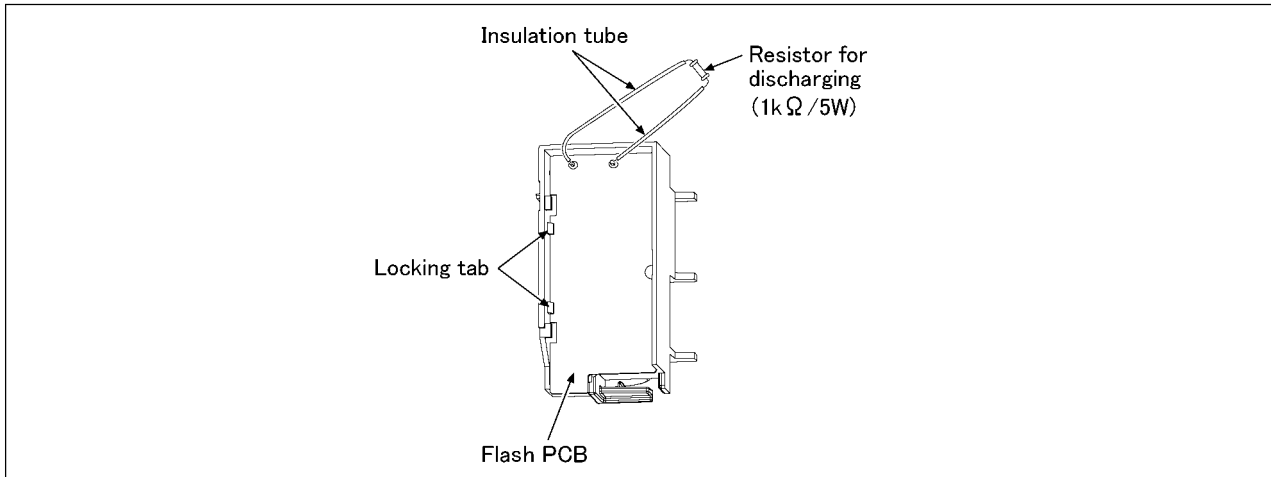

Fig. F1

## 2 Warning

### 2.1. Prevention of Electro Static Discharge (ESD) to Electrostatically Sensitive (ES) Devices

Some semiconductor (solid state) devices can be damaged easily by static electricity. Such components commonly are called Electrostatically Sensitive (ES) Devices.

Examples of typical ES devices are CCD image sensor, IC (integrated circuits) and some field-effect transistors and semiconductor "chip" components.

The following techniques should be used to help reduce the incidence of component damage caused by electro static discharge (ESD).

1. Immediately before handling any semiconductor component or semiconductor-equipped assembly, drain off any ESD on your body by touching a known earth ground. Alternatively, obtain and wear a commercially available discharging ESD wrist strap, which should be removed for potential shock reasons prior to applying power to the unit under test.
2. After removing an electrical assembly equipped with ES devices, place the assembly on a conductive surface such as aluminum foil, to prevent electrostatic charge buildup or exposure of the assembly.
3. Use only a grounded-tip soldering iron to solder or unsolder ES devices.
4. Use only an antistatic solder removal device. Some solder removal devices not classified as "antistatic (ESD protected)" can generate electrical charge sufficient to damage ES devices.
5. Do not use freon-propelled chemicals. These can generate electrical charges sufficient to damage ES devices.
6. Do not remove a replacement ES device from its protective package until immediately before you are ready to install it. (Most replacement ES devices are packaged with leads electrically shorted together by conductive foam, aluminum foil or comparable conductive material).
7. Immediately before removing the protective material from the leads of a replacement ES device, touch the protective material to the chassis or circuit assembly into which the device will be installed.

**CAUTION :**

Be sure no power is applied to the chassis or circuit, and observe all other safety precautions.

8. Minimize bodily motions when handling unpackaged replacement ES devices. (Otherwise harmless motion such as the brushing together of your clothes fabric or the lifting of your foot from a carpeted floor can generate static electricity (ESD) sufficient to damage an ES device).

### 2.2. How to Recycle the Lithium Ion Battery (U.S. Only)

**ENGLISH**



A lithium ion/polymer battery that is recyclable powers the product you have purchased. Please call 1-800-8-BATTERY for information on how to recycle this battery.

**FRANÇAIS**



L'appareil que vous vous êtes procuré est alimenté par une batterie au lithium-ion/polymère recyclable. Pour des renseignements sur le recyclage de la batterie, veuillez composer le 1-800-8-BATTERY.

## 2.3. Caution for AC Cord (For EB/GC/SG)

### 2.3.1. Information for Your Safety

#### IMPORTANT

Your attention is drawn to the fact that recording of pre-recorded tapes or discs or other published or broadcast material may infringe copyright laws.

#### WARNING

To reduce the risk of fire or shock hazard, do not expose this equipment to rain or moisture.

#### CAUTION

To reduce the risk of fire or shock hazard and annoying interference, use the recommended accessories only.

#### FOR YOUR SAFETY

##### DO NOT REMOVE THE OUTER COVER

To prevent electric shock, do not remove the cover. No user serviceable parts inside. Refer servicing to qualified service personnel.

### 2.3.2. Caution for AC Mains Lead

For your safety, please read the following text carefully.

This appliance is supplied with a moulded three-pin mains plug for your safety and convenience.

A 5-ampere fuse is fitted in this plug.

Should the fuse need to be replaced please ensure that the replacement fuse has a rating of 5 amperes and it is approved by ASTA or BSI to BS1362

Check for the ASRA mark or the BSI mark on the body of the fuse.



If the plug contains a removable fuse cover you must ensure that it is refitted when the fuse is replaced.

If you lose the fuse cover, the plug must not be used until a replacement cover is obtained.

A replacement fuse cover can be purchased from your local Panasonic Dealer.

If the fitted moulded plug is unsuitable for the socket outlet in your home then the fuse should be removed and the plug cut off and disposed of safely.

There is a danger of severe electrical shock if the cut off plug is inserted into any 13-ampere socket.

If a new plug is to be fitted please observe the wiring code as shown below.

If in any doubt, please consult a qualified electrician.

### 2.3.2.1. Important

The wires in this mains lead are coloured in accordance with the following code:

Blue	Neutral
Brown	Live

As the colours of the wires in the mains lead of this appliance may not correspond with the coloured markings identifying the terminals in your plug, proceed as follows:

The wire which is coloured BLUE must be connected to the terminal in the plug which is marked with the letter N or coloured BLACK.

The wire which is coloured BROWN must be connected to the terminal in the plug which is marked with the letter L or coloured RED.

Under no circumstances should either of these wires be connected to the earth terminal of the three pin plug, marked with the letter E or the Earth Symbol.



### 2.3.2.2. Before Use

Remove the Connector Cover as follows.

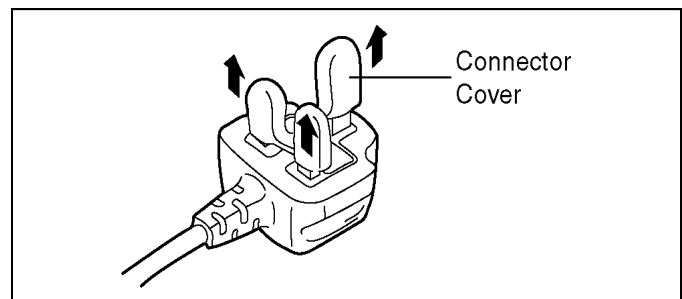

### 2.3.2.3. How to Replace the Fuse

1. Remove the Fuse Cover with a screwdriver.

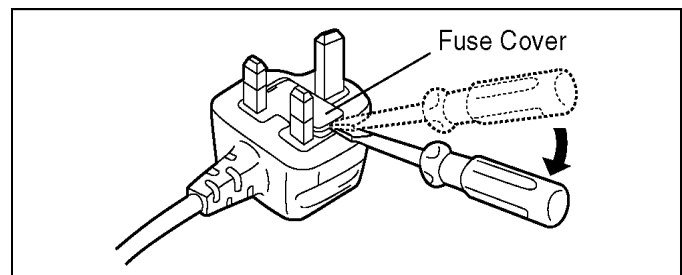

2. Replace the fuse and attach the Fuse cover.

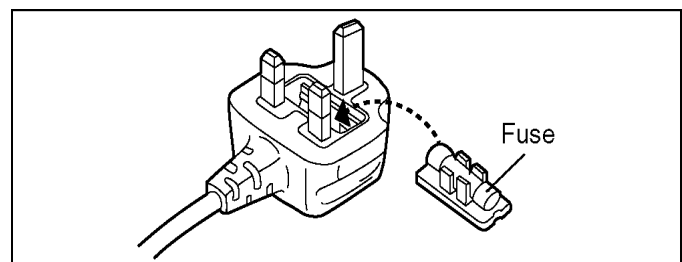

## 2.4. How to Replace the Lithium Battery

### 2.4.1. Replacement Procedure

1. Remove the MAIN PCB. (Refer to Disassembly Procedures.)
2. Remove the Lithium battery (Ref. No. "Z9101" at component side of MAIN PCB) and then replace it into new one.

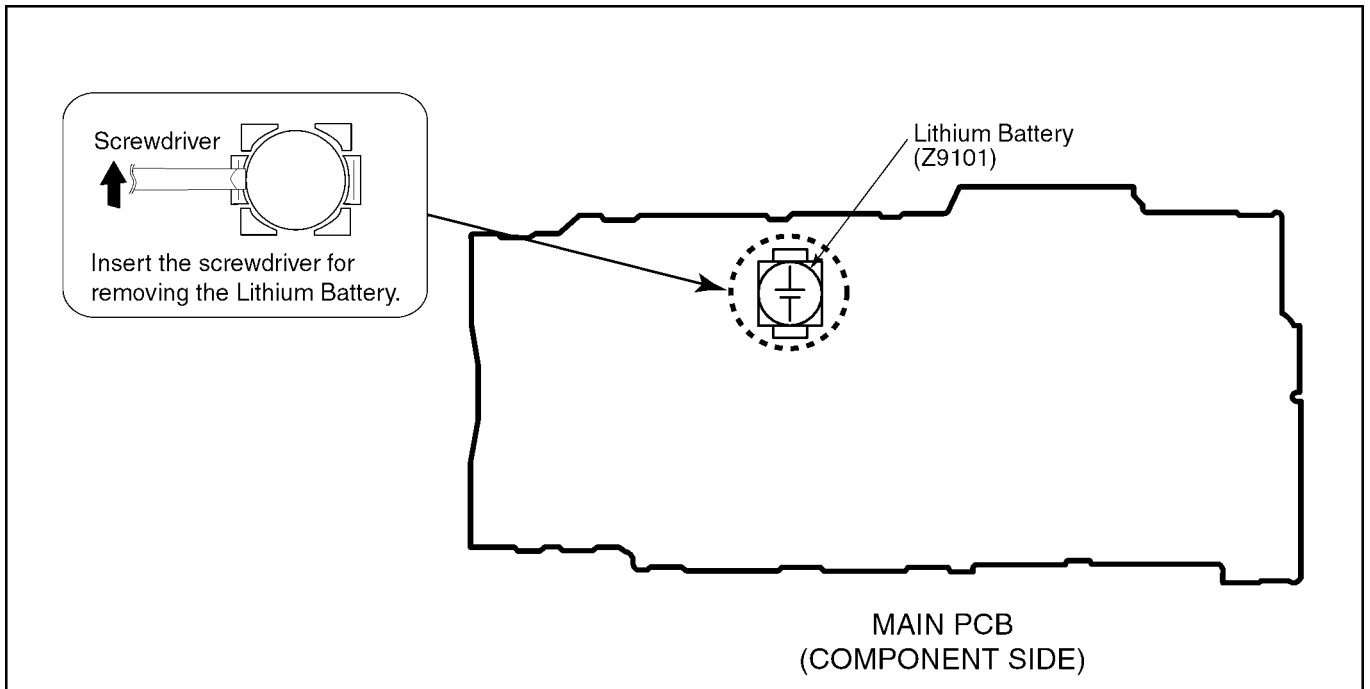

#### NOTE:

This Lithium battery is a critical component.

(Type No.: ML-614S/ZT **Manufactured by Matsushita Battery Industrial Co.,Ltd.**)

It must never be subjected to excessive heat or discharge.

It must therefore only be fitted in requirement designed specifically for its use.

Replacement batteries must be of same type and manufacture.

They must be fitted in the same manner and location as the original battery, with the correct polarity contacts observed.

Do not attempt to re-charge the old battery or re-use it for any other purpose.

It should be disposed of in waste products destined for burial rather than incineration.

(For English)

### **CAUTION**

Danger of explosion if battery is incorrectly replaced.  
Replace only with the same or equivalent type recommended by the manufacturer.  
Dispose of used batteries according to the manufacturer's instructions.

(For French)

### **PRECAUTION**

Le fait de remplacer incorrectement la pile peut présenter des risques d'explosion.  
Remplacer la pile uniquement par une pile identique ou de type équivalent recommandée par le fabricant. Se débarrasser des piles usagées conformément aux instructions du fabricant.

(For German)

### **VORSICHT**

Bei einer falsch eingesetzten Batterie besteht Explosionsgefahr. Nur mit einer vom Hersteller empfohlenen Batterie vom gleichen Typ ersetzen.  
Verbrauchte Batterien beim Fachhändler oder einer Sammelstelle für Sonderstoffe abliefern.

(For Swedish)

### **VARNING**

Explosionsfara vid felaktigt batteribyte.  
Använd samma batterityp eller en ekvivalent typ som rekommenderas av apparatillverkaren.  
Kassera använt batteri enligt fabrikantens instruktion.

(For Norwegian)

### **ADVARSEL!**

Lithiumbatteri-Eksplosionsfare ved fejløst håndtering.  
Udskiftning må kun ske med batteri af samme fabrikat og type.  
Levér det brugte batteri tilbage til leverandøren.

(For Finnish)

### **VAROITUS**

Paristo voi räjähtää, jos se on virheellisesti asennettu.  
Vaihda paristo ainoastaan laitevalmistajan suosittelemaan tyyppiin.  
Hävitä käytetty paristo valmistajan ohjeiden mukaisesti.

#### **NOTE:**

Above caution is applicable for a battery pack which is for DMC-FZ50 series, as well.



## 3 Service Navigation

### 3.1. Introduction

This service manual contains technical information, which allow service personnel's to understand and service this model. Please place orders using the parts list and not the drawing reference numbers.

If the circuit is changed or modified, the information will be followed by service manual to be controlled with original service manual.

### 3.2. General Description About Lead Free Solder (PbF)

The lead free solder has been used in the mounting process of all electrical components on the printed circuit boards used for this equipment in considering the globally environmental conservation.

The normal solder is the alloy of tin (Sn) and lead (Pb). On the other hand, the lead free solder is the alloy mainly consists of tin (Sn), silver (Ag) and Copper (Cu), and the melting point of the lead free solder is higher approx.30°C (86°F) more than that of the normal solder.

#### Distinction of PCB Lead Free Solder being used

The letter of "PbF" is printed either foil side or components side on the PCB using the lead free solder.(See right figure)	PbF
---	-----

#### Service caution for repair work using Lead Free Solder (PbF)

- The lead free solder has to be used when repairing the equipment for which the lead free solder is used.  
(Definition: The letter of "PbF" is printed on the PCB using the lead free solder.)
- To put lead free solder, it should be well molten and mixed with the original lead free solder.
- Remove the remaining lead free solder on the PCB cleanly for soldering of the new IC.
- Since the melting point of the lead free solder is higher than that of the normal lead solder, it takes the longer time to melt the lead free solder.
- Use the soldering iron (more than 70W) equipped with the temperature control after setting the temperature at 350±30°C (662±86°F).

#### Recommended Lead Free Solder (Service Parts Route.)

- The following 3 types of lead free solder are available through the service parts route.  
RFKZ03D01K----- (0.3mm 100g Reel)  
RFKZ06D01K----- (0.6mm 100g Reel)  
RFKZ10D01K----- (1.0mm 100g Reel)

#### Note

\* Ingredient: tin (Sn) 96.5%, silver (Ag) 3.0%, Copper (Cu) 0.5%, Cobalt (Co) / Germanium (Ge) 0.1 to 0.3%

### 3.3. Important Notice 1:(Other than U.S.A. and Canadian Market)

1. The service manual does not contain the following information, because of the impossibility of servicing at component level.
  - a. Schematic diagram, Block Diagram and PCB layout of Main PCB.
  - b. Parts list for individual parts of Main PCB.When a part replacement is required for repairing Main PCB, replace as an assembled parts. (Main PCB)
2. The following category is/are recycle module part. please send it/them to Central Repair Center.
  - MAIN PCB (VEP56036A) : Excluding replacement of Lithium Battery

### 3.4. How to Define the Model Suffix (NTSC or PAL model)

There are seven kinds of DMC-FZ50, regardless of the colours.







- a) DMC-FZ50S
- b) DMC-FZ50PP
- c) DMC-FZ50EB/EF/EG/EGM/GN
- d) DMC-FZ50EE
- e) DMC-FZ50GD
- f) DMC-FZ50GT
- g) DMC-FZ50PL/GC/GK/SG

(DMC-FZ50S is exclusively Japan domestic model.)

What is the difference is that the "INITIAL SETTING" data which is stored in Flash ROM mounted on Main PCB.

#### 3.4.1. Defining methods:

To define the model suffix to be serviced, refer to the nameplate which is putted on the bottom side of the Unit.

<p><b>a) DMC-FZ50S</b> DMC-FZ50S is exclusively Japan domestic model.</p>		
<p><b>b) DMC-FZ50PP</b> The nameplate for this model show the following Safty registration mark.</p> 	 <p>Safty registration mark</p>	
<p><b>c) DMC-FZ50EB/EF/EG/EGM/GN</b> The nameplate for these models show the following Safty registration mark.</p> 		
<p><b>d) DMC-FZ50EE</b> The nameplate for this model show the following Safty registration mark.</p> 		
<p><b>e) DMC-FZ50GD</b> The nameplate for this model show the following Safty registration mark.</p> 		
<p><b>f) DMC-FZ50GT</b> The nameplate for this model show the following Safty registration mark.</p> 		
<p><b>g) DMC-FZ50PL/GC/GK/SG</b> The nameplate for these models do not show any above Safty registration mark.</p>		

#### NOTE:

After replacing the MAIN PCB, be sure to achieve adjustment.

The adjustment instruction is available at "software download" on the "Support Information from NWBG-PAVC" web-site in "TSN system", together with Maintenance software.

### 3.4.2. INITIAL SETTINGS:

**CAUTION:**

NEVER select "NONE(JAPAN)" if the unit is other than "JAPAN" model.  
Other-wise, it can not be reset to the others.

When you replace the Main PCB be sure to perform the initial settings after achieving the Adjustment, by ordering the following procedure in accordance with model suffix.

• **Step 1. The temporary cancellation of factory setting:**

Set the mode dial to "[ P ]".

While keep pressing [ Optical Image Stabilizer ] and "[ UP ] of Cross key" simultaneously, turn the Power on.

• **Step 2. The cancellation of factory setting:**

Set the mode dial to "[ Playback ]".

Press [ Optical Image Stabilizer ] and "[ UP ] of Cross key" simultaneously, then turn the Power off.

• **Step 3. Turn the Power on:**

Set the mode dial to "[ P ]", and then turn the Power on.

• **Step 4. Display the INITIAL SETTING:**

While keep pressing [ MENU ] and "[ RIGHT ] of Cross key" simultaneously, turn the Power off.

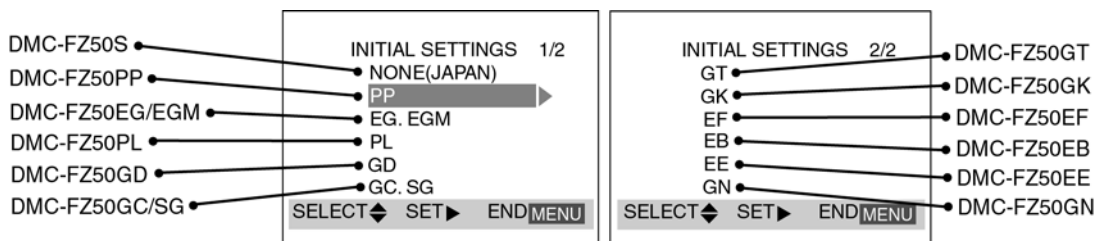

• **Step 5. Set the INITIAL SETTING:**

Select the area with pressing "[ UP ] / [ DOWN ] of Cross key", and then press the "[ RIGHT ] of Cross key".

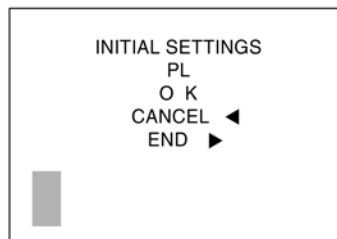

The only set area is displayed, and then press the "[ RIGHT ] of Cross key" after confirmation.

(The unit is powered off automatically.)

Confirm the display of "PLEASE SET THE CLOCK" in English when the unit is turned on again.

• **Step 6. CONFIRMATION:**

The display shows "PLEASE SET THE CLOCK" when turn the Power on again.

When the unit is connected to PC with USB cable, it is detected as removable media.

(When the "GT" or "GK" model suffix is selected, the display shows "PLEASE SET THE CLOCK" in Chinese.)

1) As for your reference Default setting condition is given in the following table.

• **Default setting (After "INITIAL SETTINGS")**

	MODEL	VIDEO OUTPUT	LANGUAGE	DATE	REMARKS
a)	DMC-FZ50S	NTSC	Japanese	Year/Month/Date	
b)	DMC-FZ50PP/PL	NTSC	English	Month/Date/Year	
c)	DMC-FZ50EB/EE/EF/EG/EGM/GC/GN/SG	PAL	English	Date/Month/Year	
d)	DMC-FZ50GK	PAL	Chinese (simplified)	Year/Month/Date	
e)	DMC-FZ50GT	NTSC	Chinese (traditional)	Year/Month/Date	
f)	DMC-FZ50GD	NTSC	English	Year/Month/Date	

# 4 Specifications

**Digital Camera:** Information for your safety

<b>Power Source:</b>	DC 8.4 V
<b>Power Consumption:</b>	1.7 W (When recording with LCD Monitor) 1.7 W (When recording with Viewfinder) 1.0 W (When playing back with LCD Monitor) 1.0 W (When playing back with Viewfinder)

**Camera Effective pixels:** 10,100,000 pixels  
**Image sensor:** 1/1.8" CCD, total pixel number 10,370,000 pixels  
 Primary color filter  
**Lens:** Optical 12× zoom, f=7.4 mm to 88.8 mm (35 mm film camera equivalent: 35 mm to 420 mm)/F2.8 to F3.7  
**Digital zoom:** Max. 4×  
**Extra optical zoom:** Max. 21.4×  
**Focus:** Normal/AF MACRO/Manual, 9-area-focusing/3-area-focusing (High speed)/1-area-focusing (High speed)/1-area-focusing/Spot-focusing AF:  
 30 cm (0.98 feet) (Wide)/2 m (6.56 feet) (Tele) to ∞  
 AF MACRO/MF:  
 5 cm (0.16 feet) (Wide)/2 m (6.56 feet) (Tele) to ∞  
 Electronic shutter+Mechanical shutter  
**Shutter system:**  
**Burst recording**  
**Burst speed:** 2 pictures/second (High speed), 1 picture/second (Low speed), Approx. 1 picture/second (Unlimited)  
**Number of recordable pictures:** Max. 5 pictures (Standard), max. 3 pictures (Fine), Depends on the remaining capacity of the card. (Unlimited) (Performance in burst recording is only with SD Memory Card/SDHC Memory Card. MultiMediaCard performance will be less.)  
**Motion picture recording:** 848×480 pixels/640×480 pixels/320×240 pixels (30 or 10 frames/second with audio. The maximum recording time depends on the capacity of the card.)  
**ISO sensitivity:** AUTO/[ISO] 100/200/400/800/1600  
 [HIGH SENS.] mode: 3200  
 60 to 1/2000th of a second  
**Shutter speed:** [STARRY SKY] mode: 15 seconds, 30 seconds, 60 seconds  
 Motion picture mode: 1/30th of a second to 1/6400th of a second  
**White balance:** AUTO/Daylight/Cloudy/Shade/Halogen/Flash/White set1/White set2  
**Exposure (AE):** Program AE (P)/Aperture-priority AE (A)/Shutter-priority AE (S)/Manual exposure (M)  
 Exposure compensation (1/3 EV Step, -2 EV to +2 EV)  
 Multiple/Center weighted/Spot  
**Metering mode:** 2.0" low-temperature polycrystalline TFT LCD  
**LCD monitor:** (207,000 pixels) (field of view ratio about 100%)

**Viewfinder:** Color LCD Viewfinder (230,000 pixels) (field of view ratio about 100%) (with diopter adjustment -4 to +4 diopter)  
**Flash:** Built-in pop up flash  
 Flash range: (ISO AUTO)  
 Approx. 30 cm (0.98 feet) to 7.4 m (24.28 feet) (Wide) AUTO, AUTO/Red-eye reduction, Forced ON (Forced ON/Red-eye reduction), Slow sync./Red-eye reduction, Forced OFF  
**Microphone:** Monaural  
**Speaker:** Monaural  
**Recording media:** SDHC Memory Card/SD Memory Card/MultiMediaCard (Still pictures only)  
**Picture size**  
**Still picture:** When the aspect ratio setting is [4.3] 3648×2736 pixels, 3264×2448 pixels, 2560×1920 pixels, 2048×1536 pixels, 1600×1200 pixels  
 When the aspect ratio setting is [6.2] 3600×2400 pixels, 3248×2160 pixels, 2560×1712 pixels, 2048×1360 pixels  
 When the aspect ratio setting is [16.9] 3584×2016 pixels, 3072×1728 pixels, 1920×1080 pixels  
**Motion pictures:** When the aspect ratio setting is [4.3] 640×480 pixels/320×240 pixels  
 When the aspect ratio setting is [16.9] 648×480 pixels  
**Quality:** Fine/Standard/RAW  
**Recording file format**  
**Still Picture:** JPEG (Design rule for Camera File system, based on Exif 2.21 standard)/ RAW, DPOF corresponding  
**Picture with audio:** JPEG (Design rule for Camera File system, based on Exif 2.21 standard)+640×480 pixels QuickTime (picture with audio) QuickTime Motion JPEG (motion pictures with audio)  
**Motion pictures:**  
**Interface**  
**Digital:** USB 2.0 (Full Speed)  
**Analog video/audio:** NTSC/PAL Composite (Switched by menu), Audio line output (monaural)  
**Terminal**  
**REMOTE:** φ 2.5 mm jack  
**AV OUT/DIGITAL:** Dedicated jack (8 pin)  
**DC IN:** type 3 jack  
**Dimensions:** 131.2 mm (W)×85.5 mm (H)×142 mm (D) (5 11/64" (W)×3 3/8" (H)×5 19/32" (D)) (excluding the projecting part)  
 Approx. 668 g/23.56 oz (excluding Memory Card and battery)  
 Approx. 714 g/25.19 oz (with Memory Card and battery)  
**Operating Temperature:** 0 °C to 40 °C (32 °F to 104 °F)  
**Operating Humidity:** 10% to 80%

**Battery Charger (Panasonic DE-993B):** Information for your safety

<b>Input:</b>	110 V to 240 V~50/60 Hz, 0.15 A
<b>Output:</b>	CHARGE 8.4 V==0.43 A

**Equipment mobility:** Movable

**Battery Pack (lithium-ion) (Panasonic CGR-S006A):** Information for your safety

<b>Voltage/capacity:</b>	7.2 V, 710 mAh
--------------------------	----------------

# 5 Location of Controls and Components

## Names of the Components

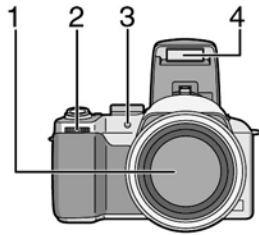

- 1 Lens
- 2 Front dial
- 3 Self-timer Indicator  
AF Assist Lamp
- 4 Flash

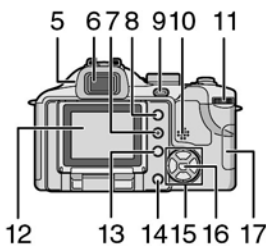

- 5 Diopter Adjustment Dial
- 6 Viewfinder
- 7 [DISPLAY] Button
- 8 [EVF/LCD] Button
- 9 [FOCUS/AE LOCK] Button
- 10 Speaker
- 11 Rear dial
- 12 LCD Monitor
- 13 [FUNCTION] Button
- 14 Delete Button
- 15 Cursor Buttons
  - ◀/Self-timer Button
  - ▼/[REV] Button
  - ▶/Flash Setting Button
  - ▲/Exposure Compensation/Auto Bracket /Flash Output Adjustment /Backlight Compensation in auto mode Button
- 16 [MENU/SET] Button
- 17 Card Door

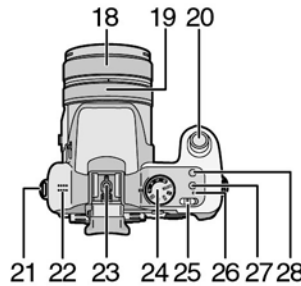

- 18 Zoom ring
- 19 Focus ring
- 20 Shutter Button
- 21 Strap Eyelet
- 22 Microphone
- 23 Hot Shoe
- 24 Mode Dial
- 25 Camera ON/OFF Switch
- 26 Power Indicator
- 27 Single or Burst Mode Button
- 28 Optical Image Stabilizer Button

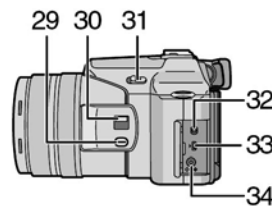

- 29 [FOCUS] Button
- 30 Focus Switch (AF/AF MACRO/MF)
- 31 Flash Open Lever
- 32 [REMOTE] Socket
- 33 [AV OUT/DIGITAL] Socket
- 34 [DC IN] Socket
  - Always use a genuine Panasonic AC adaptor (DMW-AC7; optional).

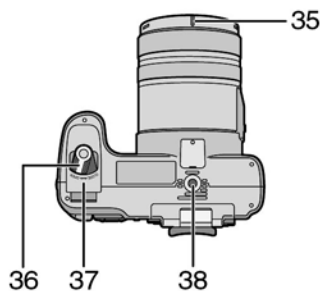

- 35 Lens hood positioning groove
- 36 Battery Door Open/Close Lever
- 37 Battery Door
- 38 Tripod Receptacle
  - When you use a tripod, make sure the tripod is stable with the camera attached to it.

## About The Mode Dial

Adjust part ① to the desired mode. The mode dial can be rotated 360°. Rotate it slowly and surely to adjust to each mode.

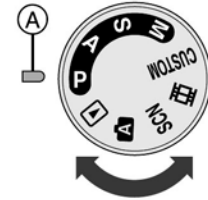

### P : Program AE mode

The exposure is automatically adjusted by the camera.

### A : Aperture-priority AE mode

The shutter speed is automatically determined by the aperture value you set.

### S : Shutter-priority AE mode

The aperture value is automatically determined by the shutter speed you set.

### M : Manual exposure mode

The exposure is adjusted by the aperture value and the shutter speed which are manually adjusted.

### CUSTOM: Custom mode

This mode allows you to save the preferred menu settings.

### Ⓜ: Motion picture mode

This mode allows you to record motion pictures.

### SCN : Scene mode

This mode allows you to take pictures depending on the recording scenes.

### Ⓐ : Auto mode

This mode is recommended for beginners.

### ▶: Playback mode

This mode allows you to play back recorded pictures.

# 6 Service Mode

## 6.1. Error Code Memory Function

### 1. General description

This unit is equipped with history of error code memory function, and can be memorized 32 error codes in sequence from the latest. When the error is occurred more than 32, oldest error is overwritten in sequence.

The error code is not memorized when the power supply is shut down forcibly (when the unit is powered on by the battery, the battery is pulled out) because the error code is memorized to FLASH ROM when the unit is powered off.

### 2. How to display

The error code can be displayed by the following procedure:

Before perform the error code memory function, connect the AC adaptor or insert the battery, and insert the SD card.

#### • 1. The temporary cancellation of factory setting:

Set the mode dial to "[ P ]".

While pressing [ Optical Image Stabilizer Button ] and "[ UP ] of Cross key" simultaneously and hold them, turn the Power on.

#### • 2. The display of error code:

Press [ Optical Image Stabilizer Button ], [ MENU ] and "[ LEFT ] of Cross key" simultaneously with the step 1 condition.

The display is changed as shown below when the above buttons is pressed simultaneously.

Normal display → Error code display → Operation history display → Normal display → .....

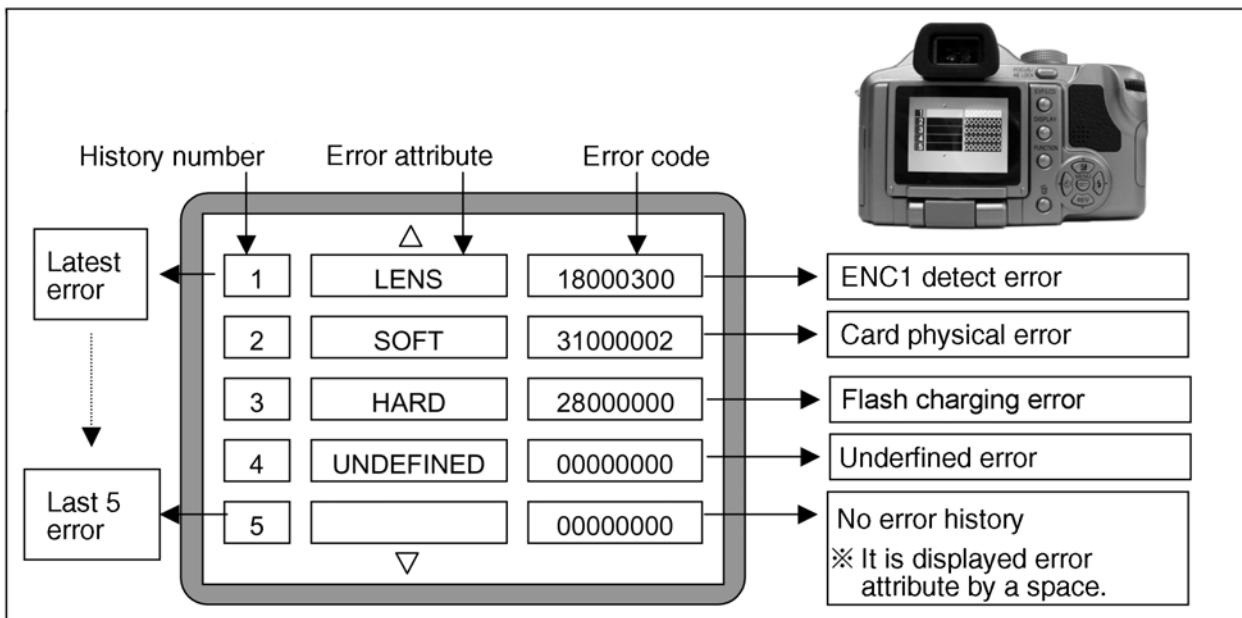

Example of Error Code Display

#### • 3. The change of display:

The error code can be memorized 32 error codes in sequence, however it is displayed 5 errors on the LCD.

Display can be changed by the following procedure:

"[ UP ] or [ DOWN ] of Cross key" : It can be scroll up or down one.

"[ LEFT ] or [ RIGHT ] of Cross key" : It can be display last 5 error or another 5 error.

#### • 4. How to read the error code:

One error code is displayed for 8 bit, the contents of error codes is indicated the table as shown below.

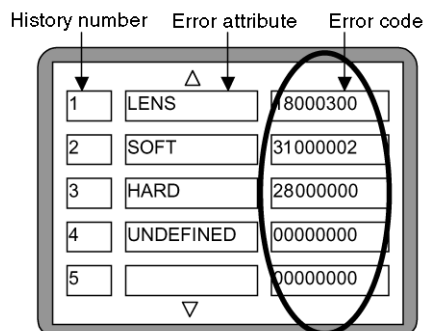

Attribute	Main item	Sub item	Error code		Contents (Upper)
			High 4 bits	Low 4 bits	Check point (Lower)
LENS	Lens drive	OIS	1800	1000	PSD (X) error. Hall element (X axis) position detect error in OIS unit. OIS Unit
				2000	PSD (Y) error. Hall element (Y axis) position detect error in OIS unit. OIS Unit
				3000	GYRO (X) error. Gyro (IC7101: X axis) detect error on Main P.C.B.. IC7101 (Gyro element) or IC6001 (VENUS 3)
				4000	GYRO (Y) error. Gyro (IC7102: Y axis) detect error on Main P.C.B.. IC7102 (Gyro element) or IC6001 (VENUS 3)
				5000	MREF error (Reference voltage error). IC7002 (LENS drive) or IC6001 (VENUS 3)
				6000	Drive voltage (X) error. VENUS 3 AD value error, LENS Unit, LENS flex breaks etc.
				7000	Drive voltage (Y) error. VENUS 3 AD value error, LENS Unit, LENS flex breaks etc.
		Focus	0001	HP Low detect error (Focus encoder always Low detect error). FP9008-(25) signal line or IC6001 (VENUS 3)	
			0002	HP High detect error (Focus encoder always High detect error). FP9008-(24) signal line or IC6001 (VENUS 3)	
			0003	MR A aspect output error FP9008-(29) signal line or IC6001 (VENUS 3)	
			0004	MR B aspect output error FP9008-(27) signal line or IC6001 (VENUS 3)	
		Lens	1801	0000	Power ON time out error. Lens drive system
				1802	0000
		Adj.History	OIS	1900	2000
	3000				OIS adj. Pitch direction amplitude error (small)
	4000				OIS adj. Yaw direction amplitude error (large)
	5000				OIS adj. Pitch direction amplitude error (large)
	6000				OIS adj. MREF error
	7000				OIS adj. time out error
	8000				OIS adj. Yaw direction off set error
	9000				OIS adj. Pitch direction off set error
	A000				OIS adj. Yaw direction gain error
	B000				OIS adj. Pitch direction gain error
	C000				OIS adj. Yaw direction position sensor error
	D000				OIS adj. Pitch direction position sensor error
	E000				OIS adj. other error
	HARD	VENUS A/D	Flash	2800	0000
FLASH ROM (EEPROM Area)		FLASH ROM (EEPROM Area)	2B00	0001	EEPROM read error IC6003 (FLASH ROM)
				0002	EEPROM write error IC6003 (FLASH ROM)
SYSTEM		RTC	2C00	0001	SYSTEM IC initialize failure error Communication between IC6001 (VENUS 3) and IC9101 (SYSTEM)

Attribute	Main item	Sub item	Error code		Contents (Upper)
			High 4 bits	Low 4 bits	Check point (Lower)
SOFT	CPU	Reset	3000	0001	NMI reset
				0007	Non Mask-able Interrupt (30000001-30000007 are caused by factors)
	Card	Card	3100	0001	Card logic error SD card data line or IC6001 (VENUS 3)
				0002	Card physical error SD card data line or IC6001 (VENUS 3)
				0004	Write error SD card data line or IC6001 (VENUS 3)
				0005	Format error SD card data line or IC6001 (VENUS 3)
				0001	Camera task finish process time out. Communication between Lens system and IC6001 (VENUS 3)
	CPU, ASIC hard	Stop	3800	0002	Camera task invalid code error. IC6001 (VENUS 3)
				0100	File time out error in recording motion image IC6001 (VENUS 3)
				0200	File data send error in recording motion image IC6001 (VENUS 3)
				0300	Single or burst recording brake time out.
				0000	FLASHROM processing early period of camera during movement.
	Operation	Power on	3B00	0000	FLASHROM processing early period of camera during movement.
	Zoom	Zoom	3C00	0000	I do not complete zoom lens processing Zoom lens
				0000	I jumped into dummy processing (0-7bit : command, 8-15bit : Status)
				0000	Though record preprocessing is necessary, it is not called.
				0000	Though record preprocessing is necessary, it is not completed.

• **5. How to returned to Normal Display:**

Turn the power off and on, to exit from Error code display mode.

**NOTE:**

The error code can not be initialized by the unit only.



## 6.2. Confirmation of Firmware Version

The Firmware version can be confirmed by ordering the following steps:

- **Step 1. The temporary cancellation of factory setting:**

Set the mode dial to "[ P ]".

Insert the SD memory card which has a few photo data.

When keep pressing [ Optical Image Stabilizer ] and "[ UP ] of Cross key" simultaneously, then turn the power on.

- **Step 2. Confirm the version:**

Set the mode dial to "[ Playback ]" and then press [ DISPLAY ] to switch to LCD with indication. (Fig. A)

Press [ Optical Image Stabilizer ] and "[ DOWN ] of Cross key" simultaneously. (No need to keep pressing.)

(The version information is displayed on the LCD with light blue colour letters.) (Fig. B)

**CAUTION:**

The version information does not display if the LCD has switched to LCD with indication already.

In this case, press [ DISPLAY ] to switch to LCD with indication.

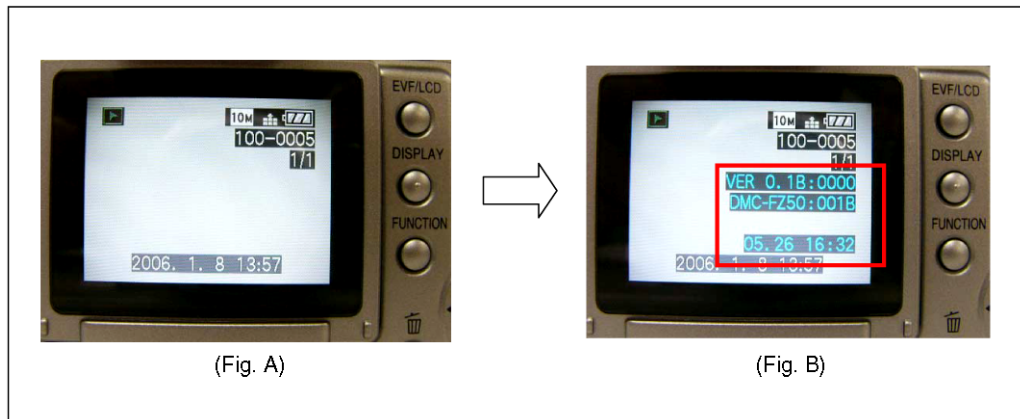
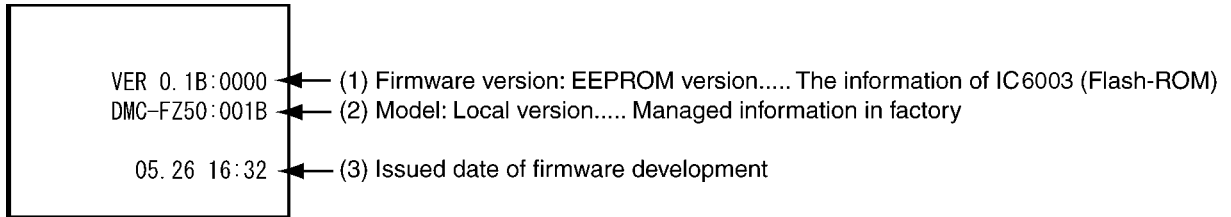



**<Point>**

- The firmware version and EEPROM version can be confirmed with the information (1).
- The information (2), (3) are just reference.

# 7 Service Fixture & Tools

## 7.1. Service Fixture and Tools

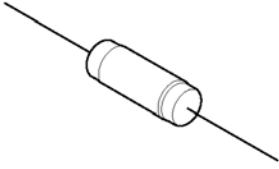
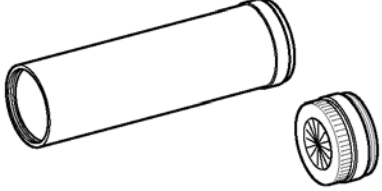
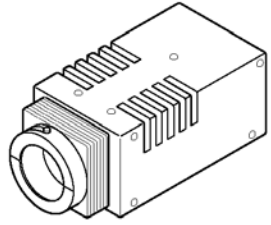
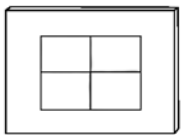
The following Service Fixture and tools are used for checking and servicing this unit.

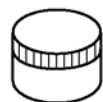
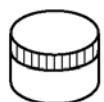
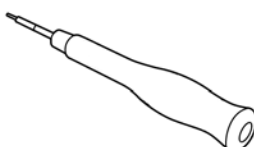
<b>Resistor for Discharging</b> <b>ERG5SJ102</b>	<b>Infinity Lens (with Focus Chart)</b> <b>VFK1164TCM02</b>	<b>LIGHT BOX</b> <b>VFK1164TDVLB</b>
 <p>An equivalent type of Resistor may be used.</p>		 <p>※ with DC Cable</p>
<b>TR Chart</b> <b>VFK1975</b>	<b>Lens Cleaning Kit (BK)</b> <b>VFK1900BK</b>	<b>Grease (for lens)</b> <b>VFK1829</b>
	 <p>* Only supplied as 10 set/box.</p>	
<b>Furoyl grease (for focus motor)</b> <b>VFK1850</b>	<b>T6 Trox driver</b> <b>VFK1981</b>	
		

## 7.2. When Replacing the Main PCB

After replacing the MAIN PCB, be sure to achieve adjustment.

The adjustment instruction is available at "software download" on the "Support Information from NWBG-PAVC" web-site in "TSN system", together with Maintenance software.

## 7.3. Service Position

This Service Position is used for checking and replacing parts. Use the following Extension cables for servicing.

Table S1 Extension Cable List

No.	Parts No.	Connection	Form
1	VFK1976	FP9007 (MAIN) - TOP OPERATION UNIT	19PIN 0.5 FFC
2	RFKZ0402	FP9009 (MAIN) - HOT SHOE UNIT	11PIN 0.5 FFC
3	VFK1980	P9002 (MAIN) - EVF UNIT	2PIN CABLE
4	VFK1461	FP9005 (MAIN) - EVF UNIT	20PIN 0.5 FFC
5	VFK1284	FP9004 (MAIN) - LCD HINGE UNIT	24PIN 0.5 FFC
6	VFK1576DC202	P9003 (MAIN) - FLASH SW UNIT	2PIN CABLE
7	VFK1480	FP9001 (MAIN) - MIC FPC UNIT	6PIN 0.5 FFC
8	VFK1441	FP9003 (MAIN) - SIDE OPERATION UNIT	8PIN 0.5 FFC
9	RFKZ0400	FP9008 (MAIN) - LENS FPC UNIT	34PIN 0.3 FFC
10	VFK1174	FP9002 (MAIN) - CCD UNIT	30PIN 0.5 FFC
11	VFK1576DC202	P9001 (MAIN) - AF ASSIST LED PCB	2PIN CABLE
12	VFK1576DSC03	P9006 (MAIN) - BATTERY CATCHER UNIT	3PIN CABLE
13	VFK1582A1225	FP9006 (MAIN) - FP8101 (FLASH)	12PIN 0.5 FFC
14	VFK1576DSC03	P9001 (FLASH) - FLASH UNIT	2PIN CABLE
15	VFK1576DC202	P9002 (FLASH) - FLASH UNIT	2PIN CABLE

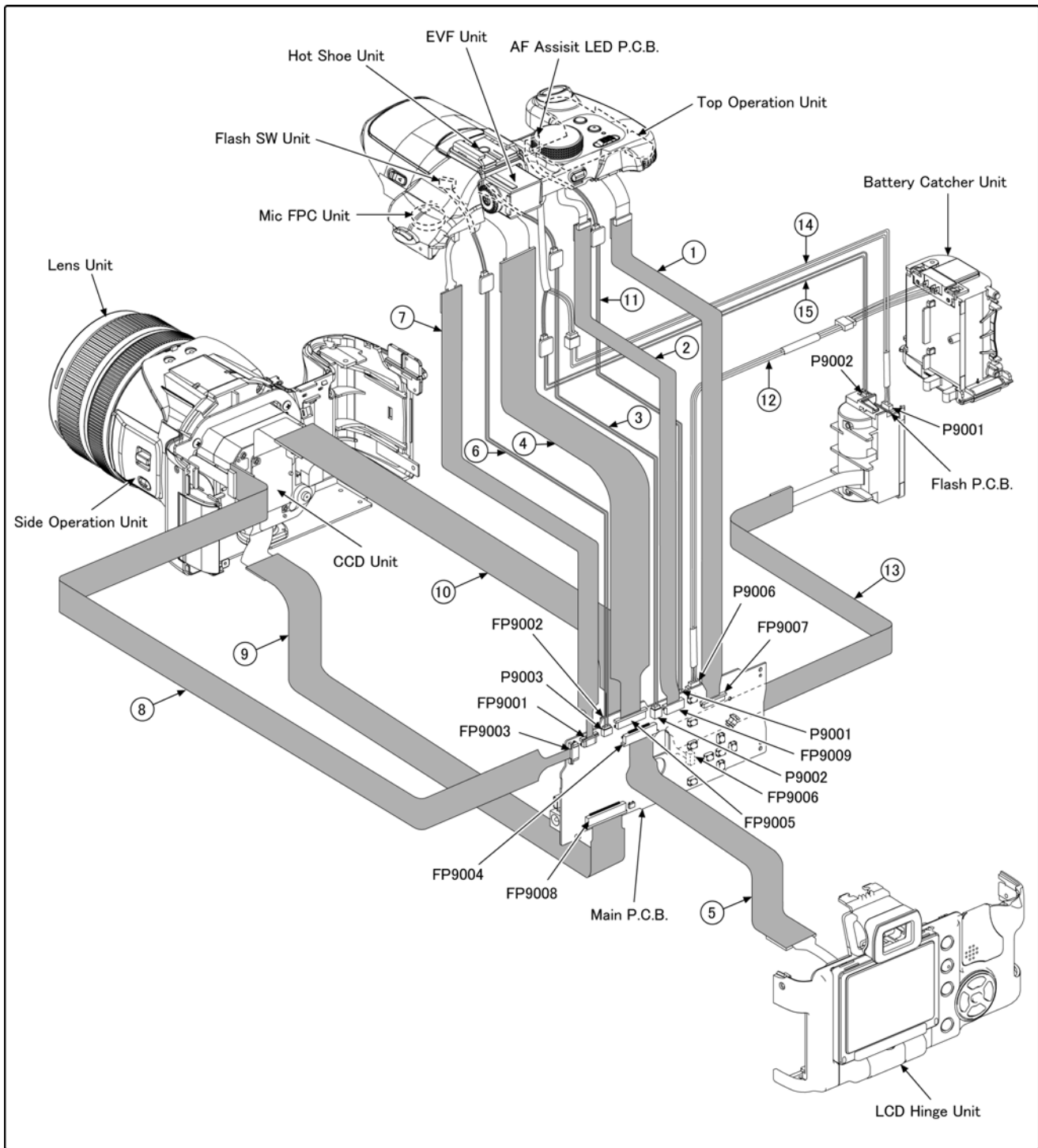

**CAUTION-1. (When servicing FLASH PCB)**

1. Be sure to discharge the capacitor on FLASH PCB.  
Refer to "HOW TO DISCHARGE THE CAPACITOR ON FLASH PCB".  
The capacitor voltage is not lowered soon even if the AC Cord is unplugged or the battery is removed.
2. Be careful of the high voltage circuit on FLASH PCB.
3. DO NOT allow other parts to touch the high voltage circuit on FLASH PCB.

# 8 Disassembly and Assembly Instructions

## 8.1. Disassembly Flow Chart

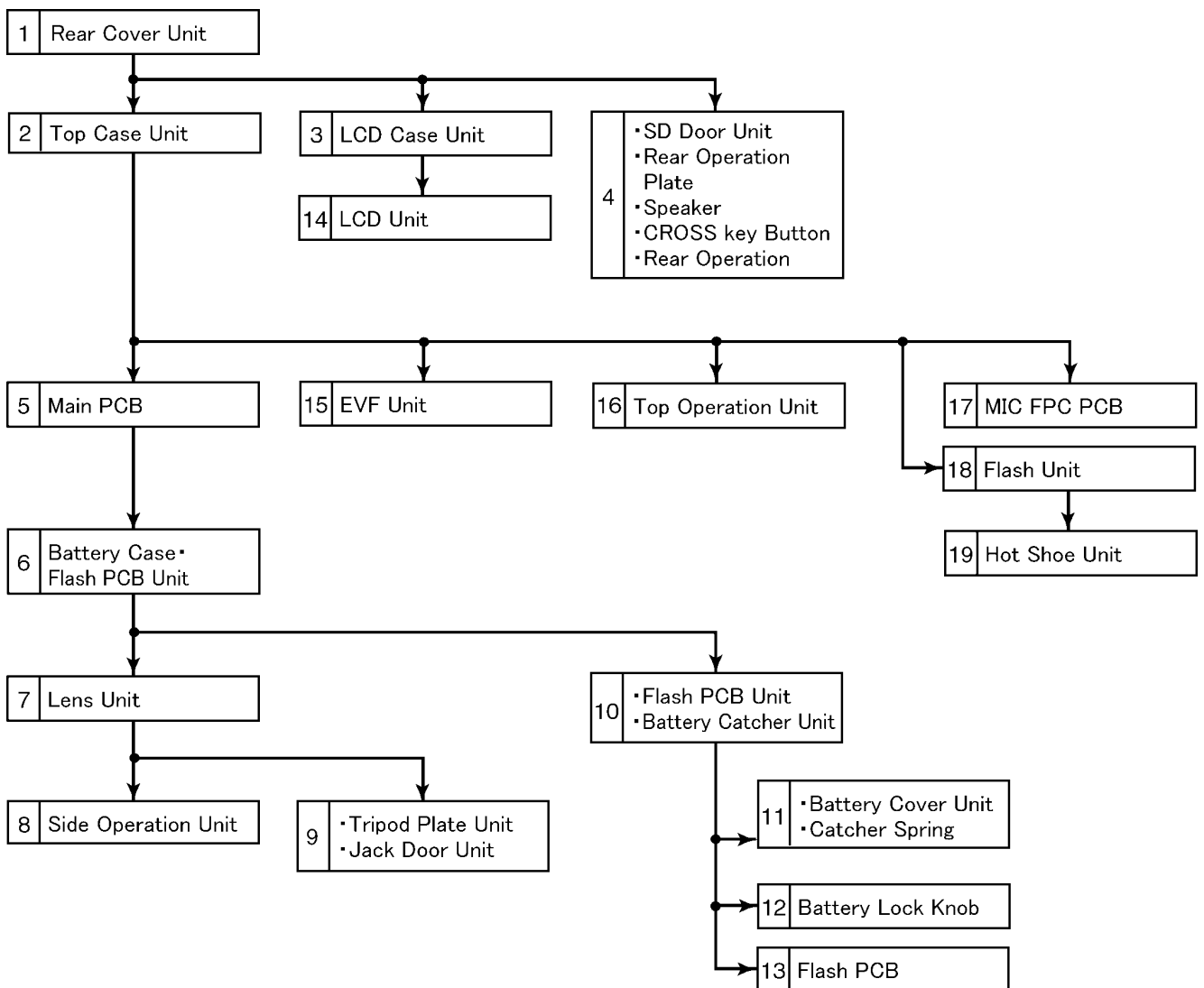

## 8.2. PCB Location

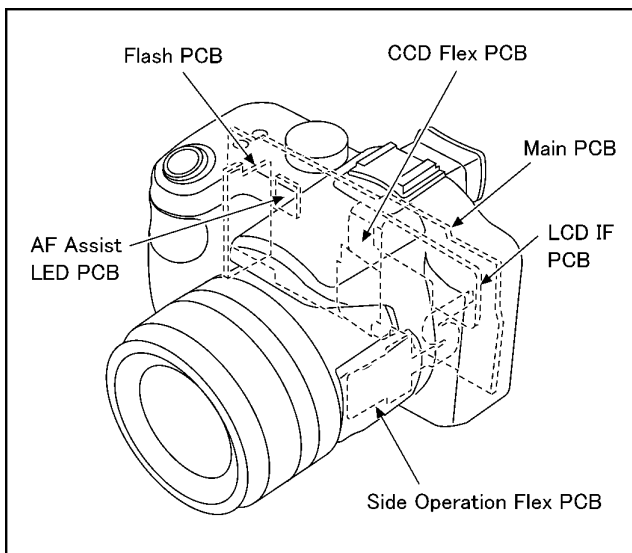

### 8.3. Disassembly Procedure

No.	Item	Fig	Removal
1	Rear Cover Unit	Fig. D1	Card
			Battery
			2 Screws (A)
			6 Screws (B)
			2 Screws (C)
			Shoe Spring
		Fig. D2	FP9004(Flex) Rear Cover Unit
2	Top Case Unit	Fig. D3	4 Screws (D)
		Fig. D4	1 Screw (D)
			FP9001(Flex)
			P9003(Connector)
			FP9005(Flex)
			P9002(Connector)
			FP9009(Flex)
			FP9007(Flex)
			P9001(Connector)
			P9006(Connector)
			P9002(Connector)
			P9001(Connector)
			Top Case Unit
3	LCD Case Unit	Fig. D5	4 Screws (E)
			4 Locking tabs
			LCD FPC Plate
			Hinge Arm Cover
			2 Locks
			LCD Case Unit
4	SD Door Unit Rear Operation Plate Speaker CROSS Key Button Rear Operation	Fig. D6	1 Screw (F)
			3 Screws (G)
			SD Door Unit
			Rear Operation Plate
			Speaker
			CROSS Key Button
			Rear Operation Button
5	Main PCB	Fig. D7	1 Screw (H)
			2 Screws (I)
			FP9002(Flex)
			FP9008(Flex)
			FP9006(Flex)
			FP9003(Flex)
			Main PCB
6	Battery Case Flash PCB Unit	Fig. D8	1 Screw (J)
			Battery Case Flash PCB Unit
7	Lens Unit	Fig. D9	4 Screws (K) Lens Unit
8	Side Operation Unit	Fig. D10	2 Screws (L)
			Side Operation Unit
9	Tripod Plate Unit Jack Door Unit	Fig. D11	4 Screws (M)
			Tripod Plate Unit
			Jack Door Unit
10	Flash PCB Unit Battery Catcher Unit	Fig. D12	1 Screw (N)
			2 Locking tabs
			Flash PCB Unit
			Battery Catcher Unit
11	Battery Cover Unit Catcher Spring	Fig. D13	Battery Cover Hinge Spring
			Battery Cover Hinge Shaft
			Battery Cover Unit
			Catcher Spring
12	Battery Lock Knob	Fig. D14	Battery Lock Shaft
			Battery Lock Spring
			Battery Lock Knob

No.	Item	Fig	Removal
13	Flash PCB	Fig. D15	2 Locking tabs
			Flash PCB
14	LCD Unit	Fig. D16	3 Screws (O)
			6 Locking tabs
			LCD Case Bottom
			FP4901(Flex)
			FP4902(Flex)
			FP4903(Flex)
		LCD Hinge Unit	
		LCD PCB	
		LCD Unit	
		Fig. D17	LCD Shield LCD Case Unit
15	EVF Unit	Fig. D18	2 Screws (P) EVF Unit
16	Top Operation Unit	Fig. D19	5 Screws (Q)
			Top Operation Unit
17	Mic FPC PCB	Fig. D20	2 Screws (R)
			Strap Holder R
			Mic Dumper Holder
			Mic Dumper
			2 Locks
			Mic FPC PCB
18	Flash Unit	Fig. D21	2 Screws (S)
			4 Locking tabs
			Flash Case top
			Flash Shaft
		Flash Spring	
Flash Unit			
Fig. D22	NOTE (When Installing)		
19	Hot Shoe Unit	Fig. D23	2 Screws (T)
			Hot Shoe Unit

### 8.3.1. Removal of the Rear Cover Unit

**NOTE:**

When servicing and reassembling, remove the card and battery from the unit.

- Card
- Battery
- Screw (A) × 2
- Screw (B) × 6
- Screw (C) × 2
- Shoe Spring

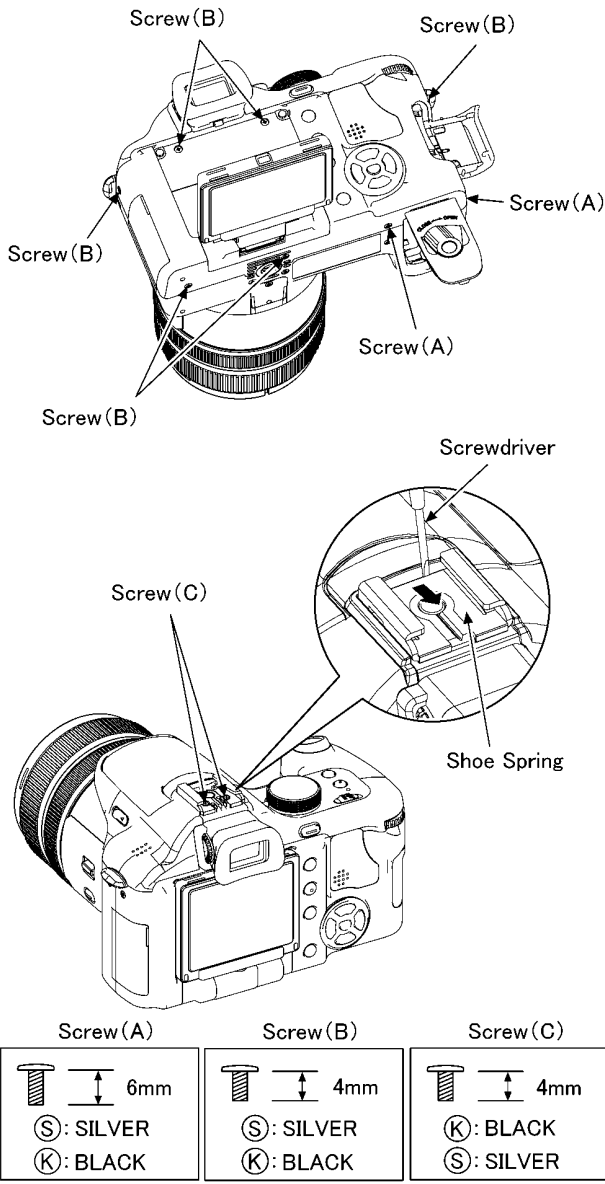
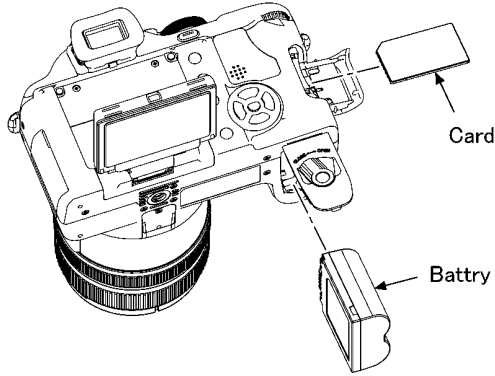

Fig. D1

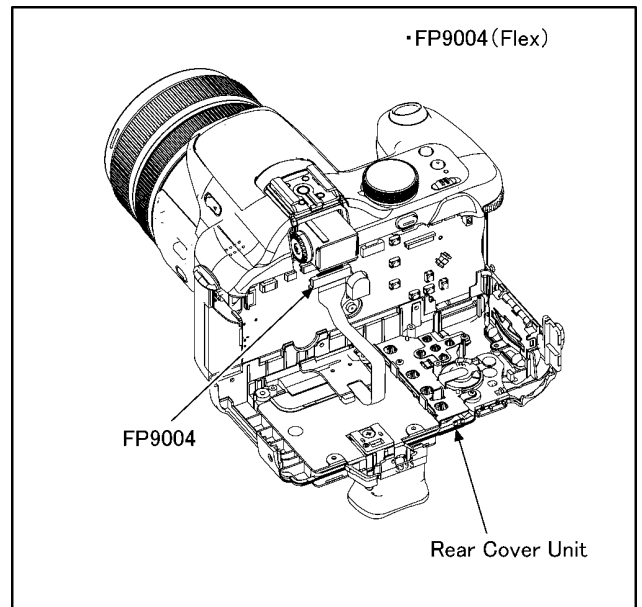

Fig. D2

### 8.3.2. Removal of the Top Case Unit

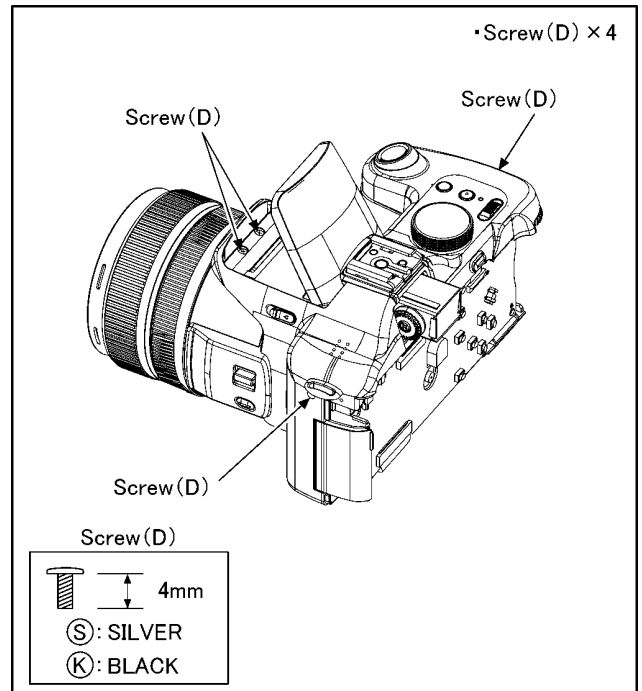

Fig. D3

### 8.3.3. Removal of the LCD Case Unit

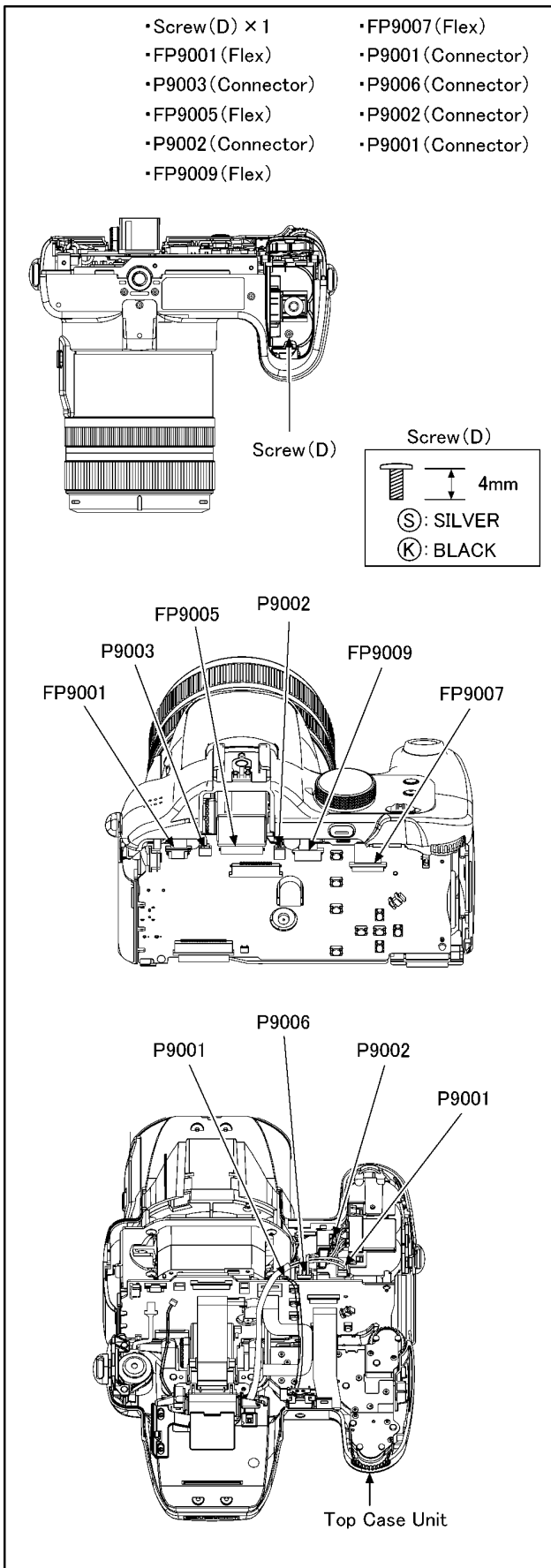

Fig. D4

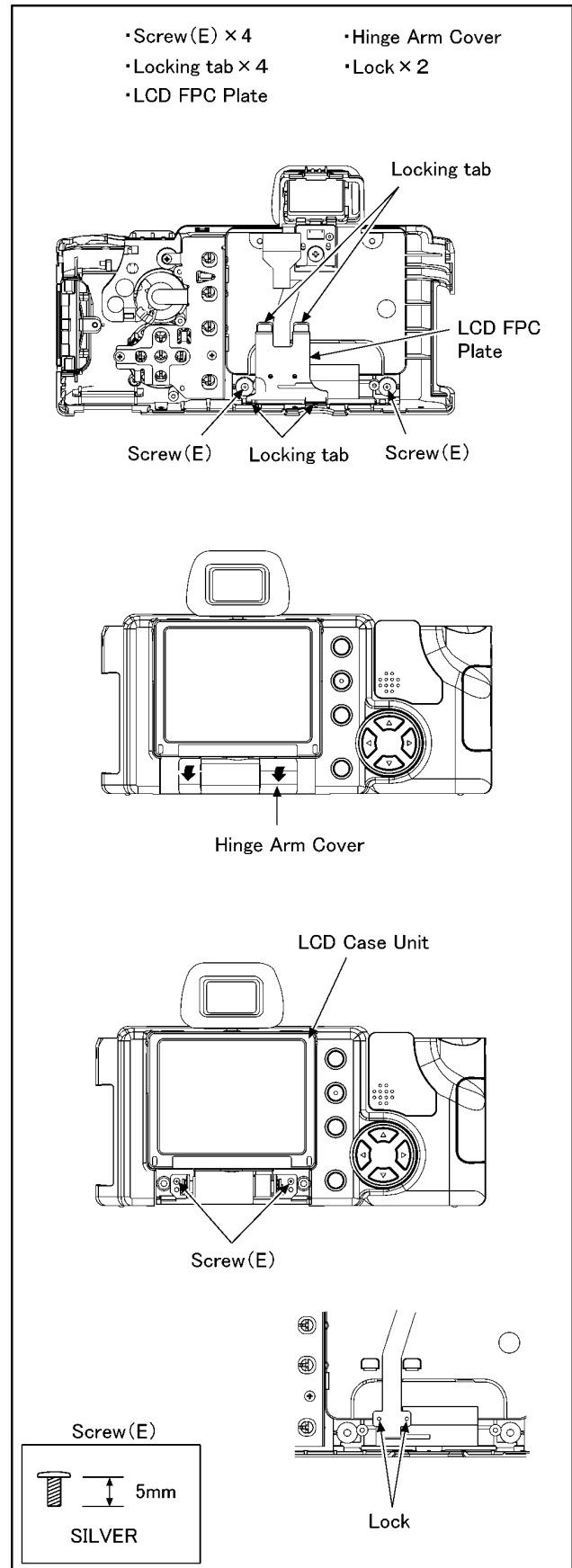

Fig. D5



### 8.3.4. Removal of the SD Door Unit, Rear Operation Plate, Speaker, CROSS Key Button, Rear Operation Button

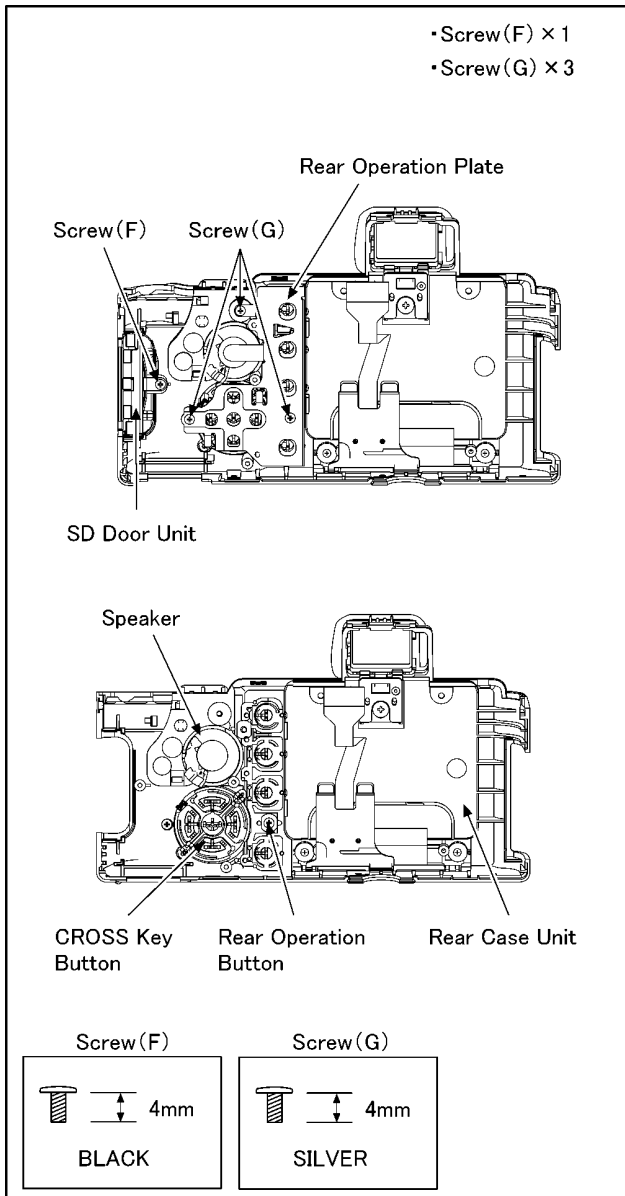

Fig. D6

### 8.3.5. Removal of the Main PCB

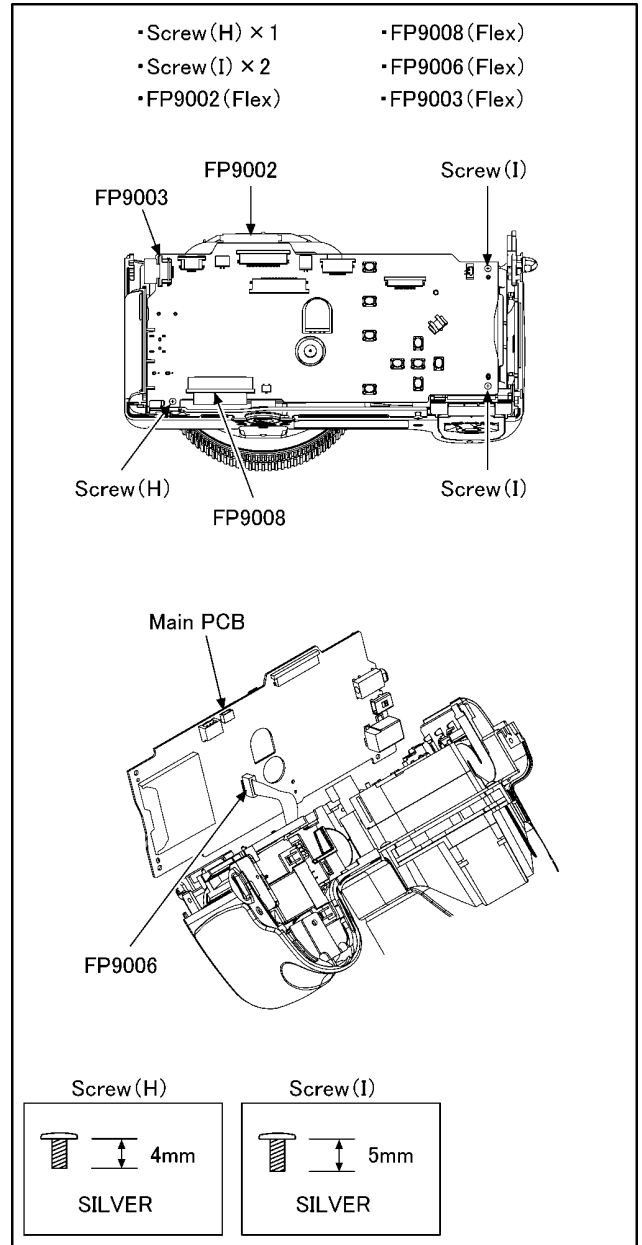

Fig. D7

### 8.3.6. Removal of the Battery Case and Flash PCB Unit

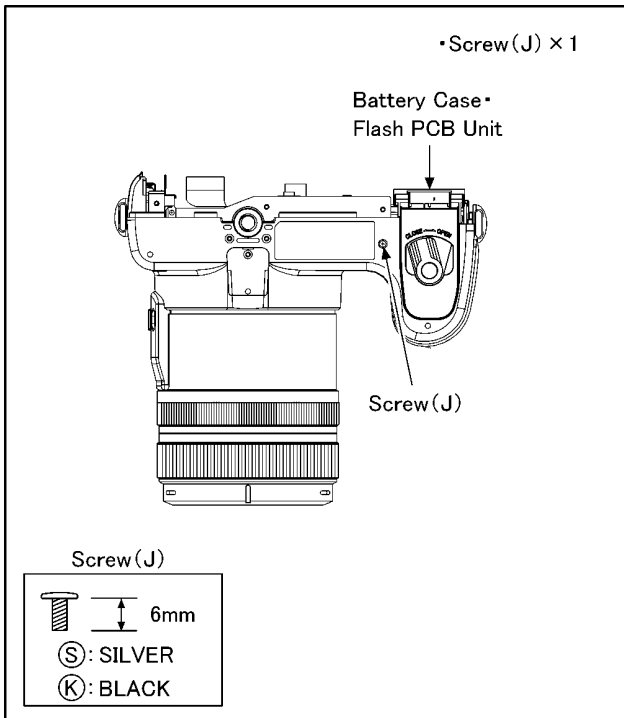

Fig. D8

### 8.3.7. Removal of the Lens Unit

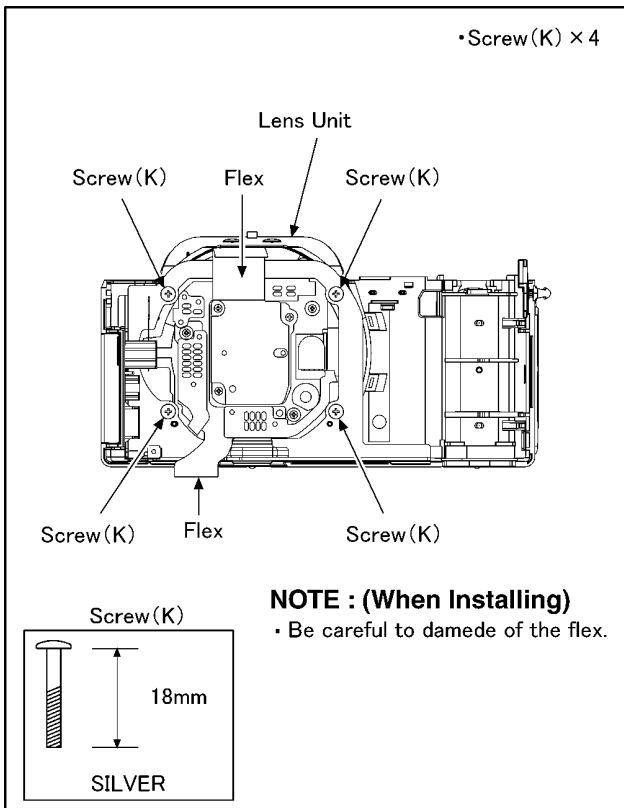

Fig. D9

### 8.3.8. Removal of the Side Operation Unit

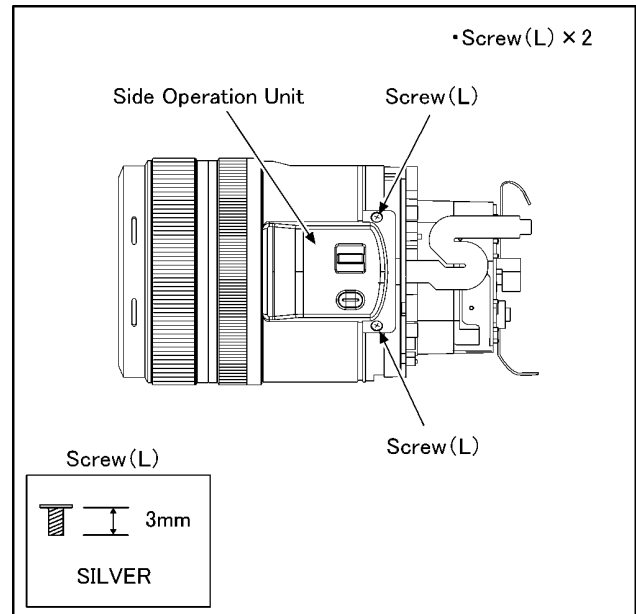

Fig. D10

### 8.3.9. Removal of the Tripod Plate Unit and Jack Door Unit

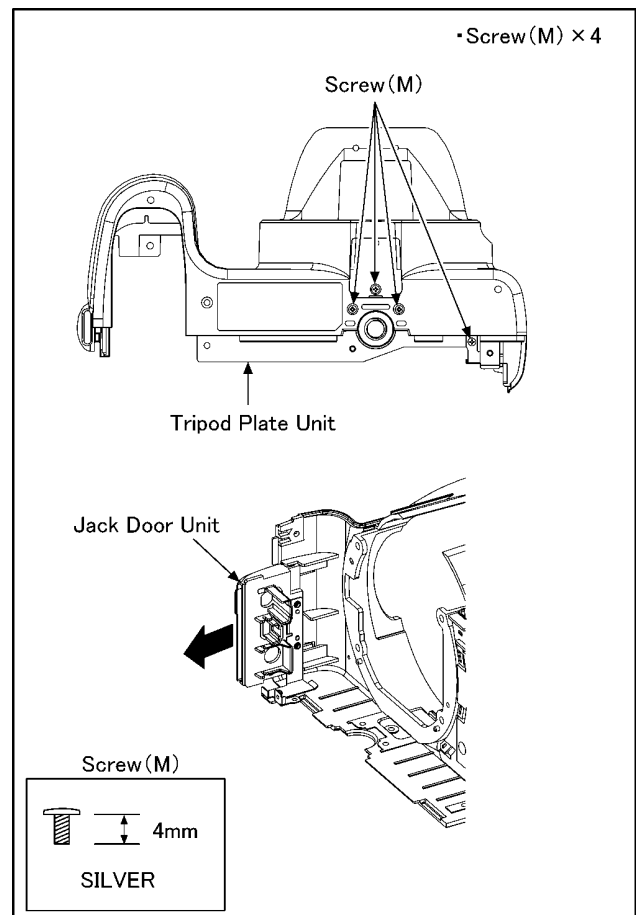

Fig. D11

### 8.3.10. Removal of the Flash PCB Unit and Battery Catcher Unit

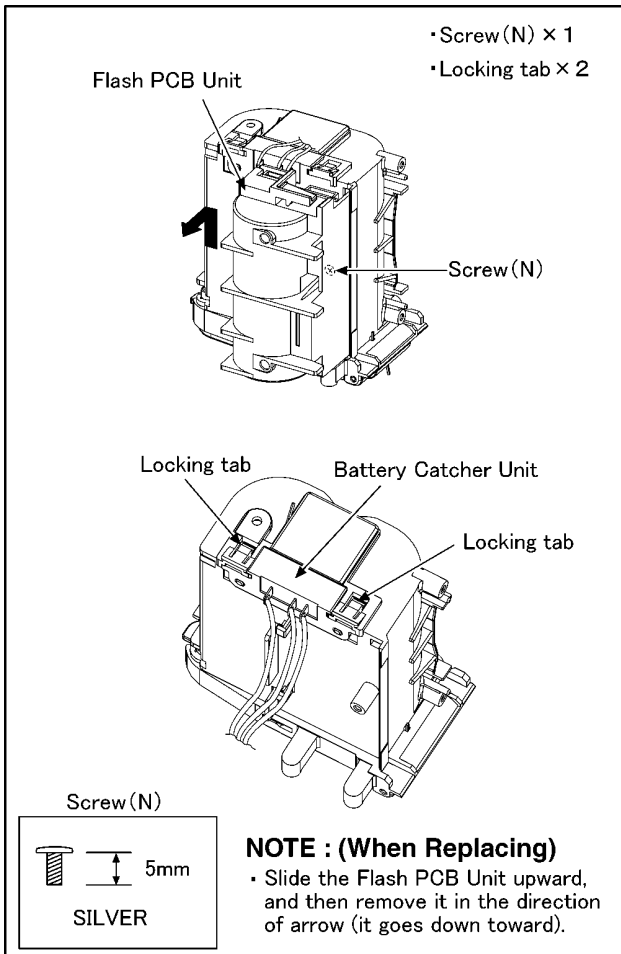

Fig. D12

### 8.3.11. Removal of the Battery Cover Unit and Catcher Spring

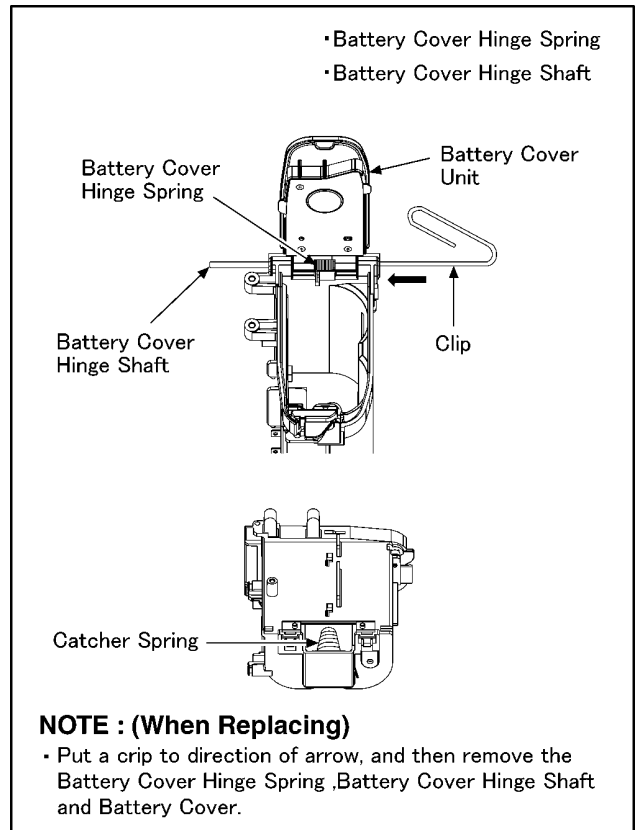

Fig. D13

### 8.3.12. Removal of the Battery Lock Knob

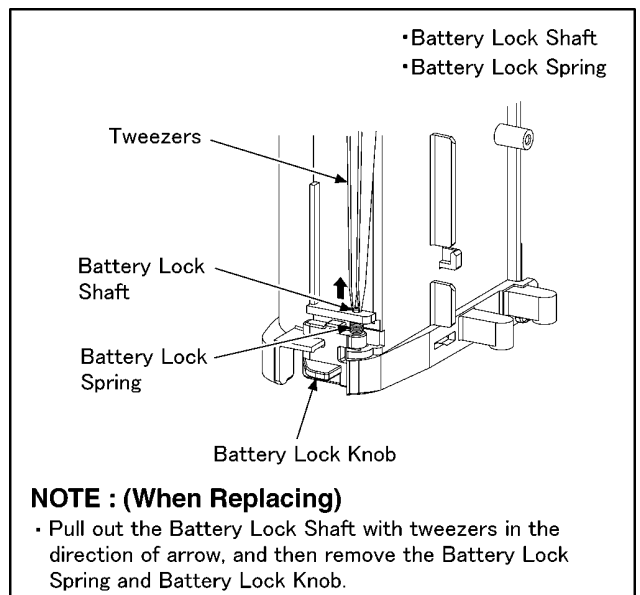

Fig. D14

### 8.3.13. Removal of the Flash PCB

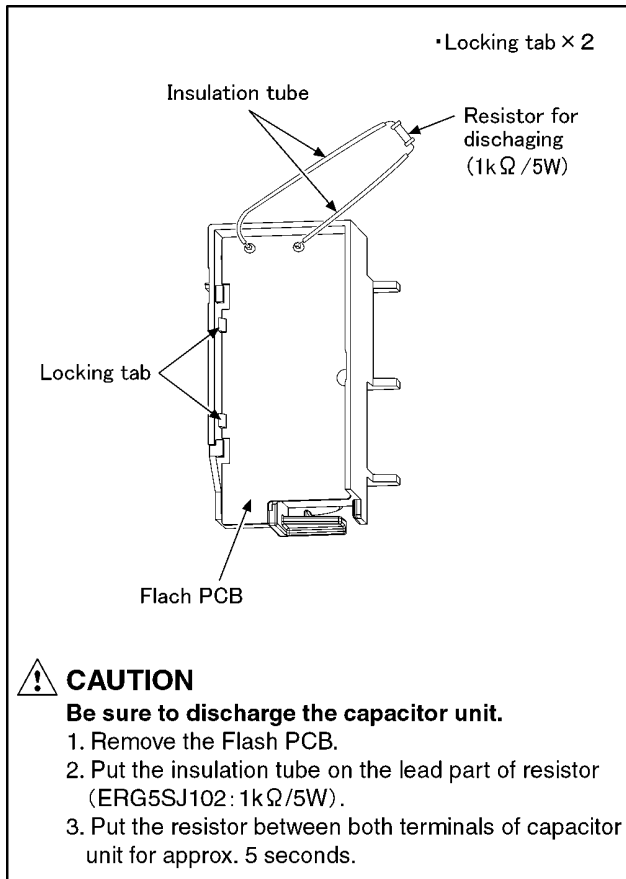

Fig. D15

### 8.3.14. Removal of the LCD Unit

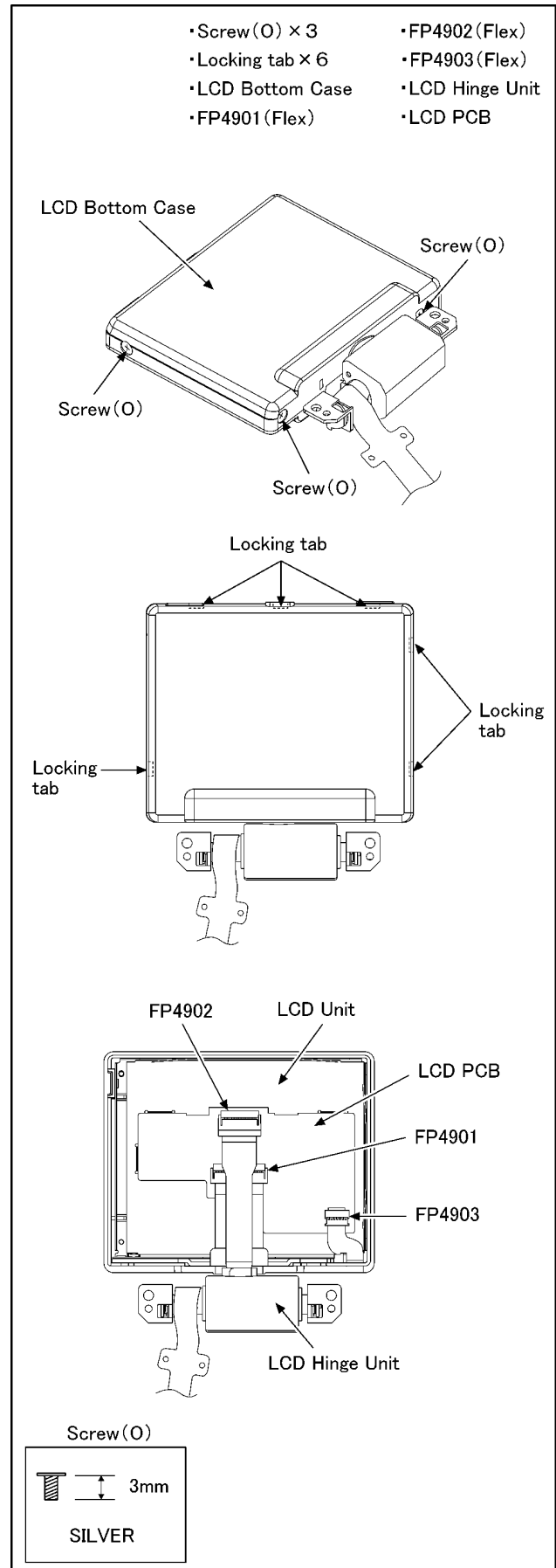

Fig. D16

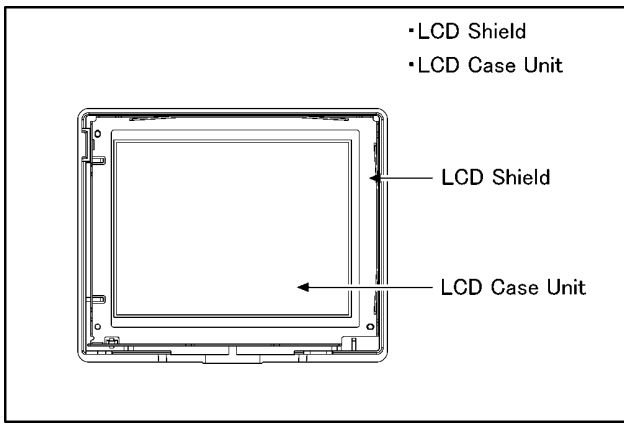

Fig. D17

### 8.3.15. Removal of the EVF Unit

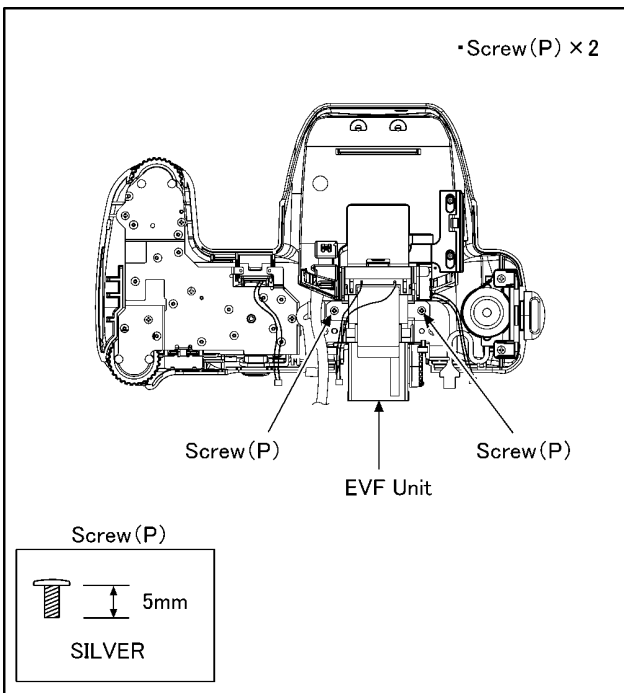

Fig. D18

### 8.3.16. Removal of the Top Operation Unit

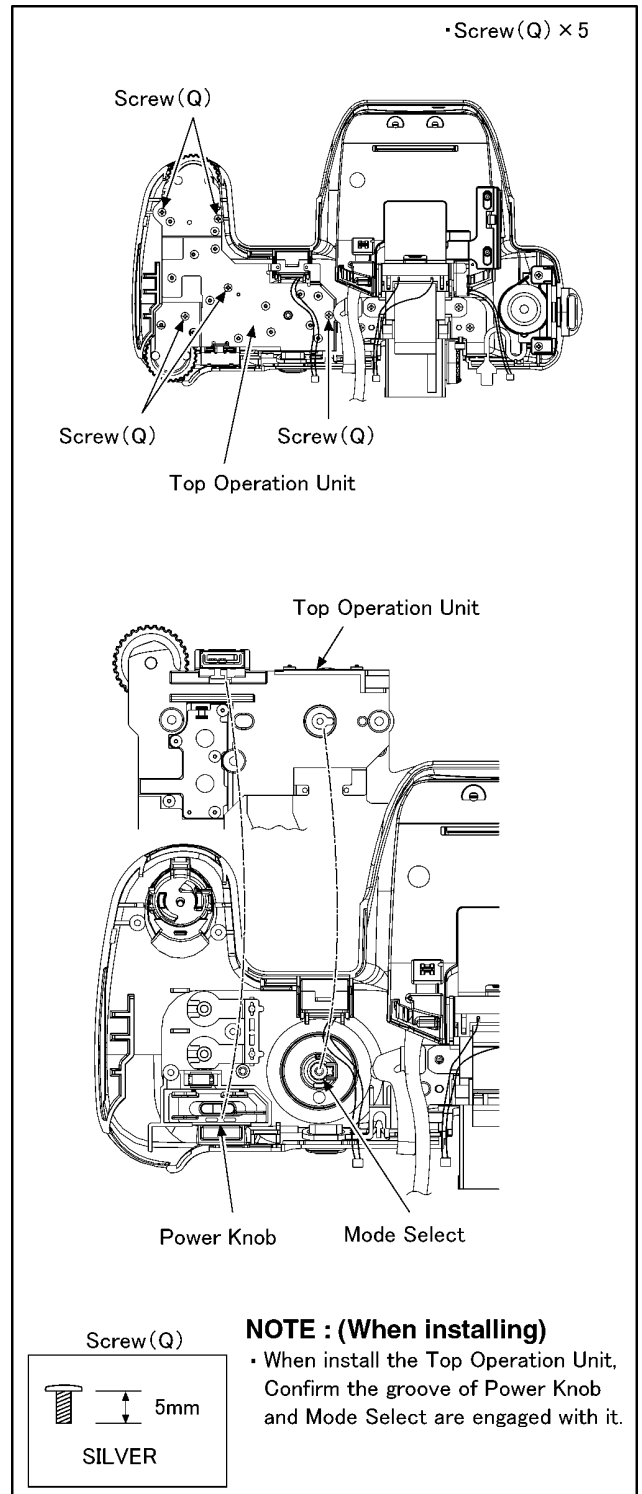

Fig. D19

### 8.3.17. Removal of the Mic FPC PCB

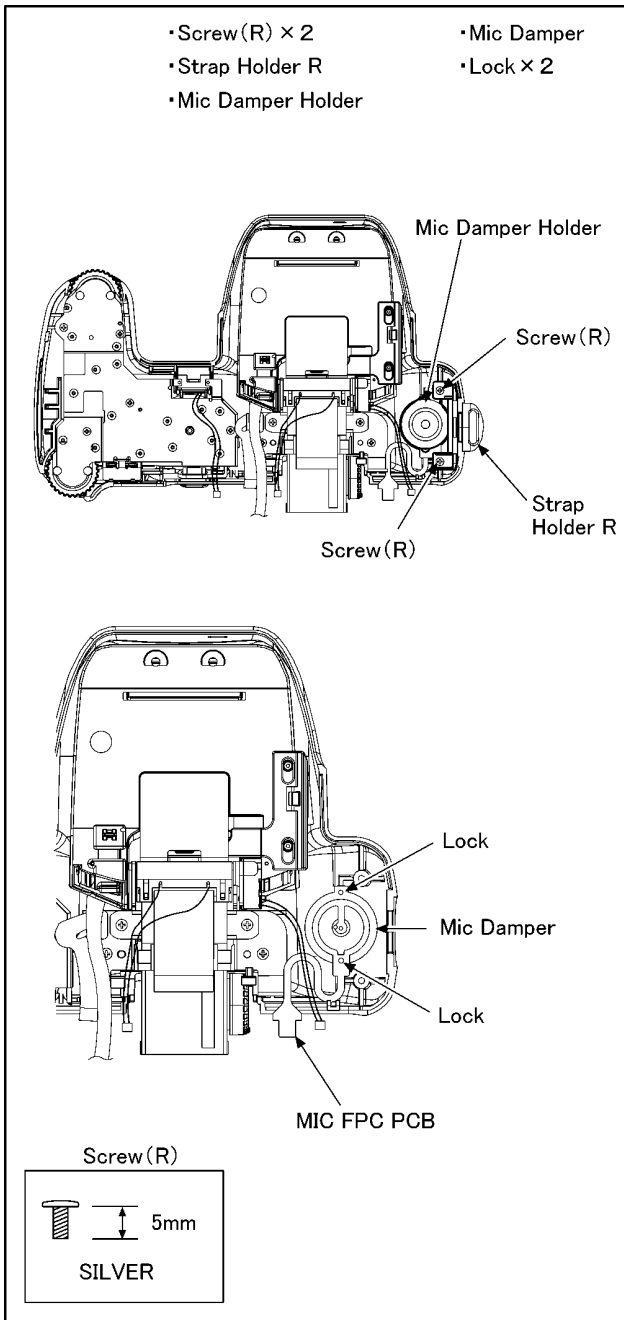

Fig. D20

### 8.3.18. Removal of the Flash Unit

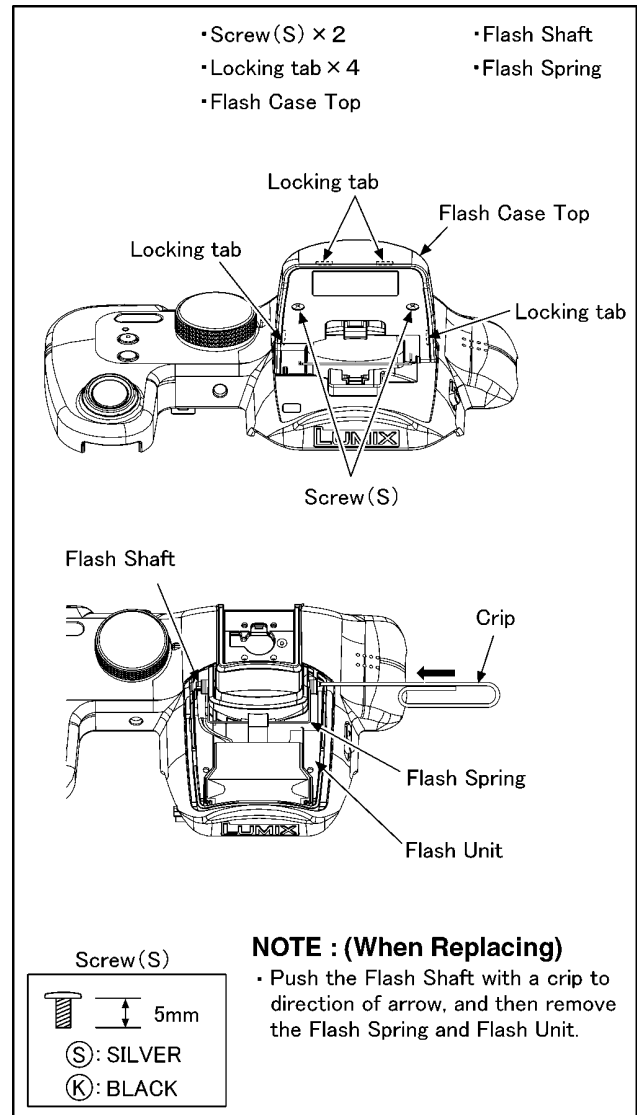

Fig. D21

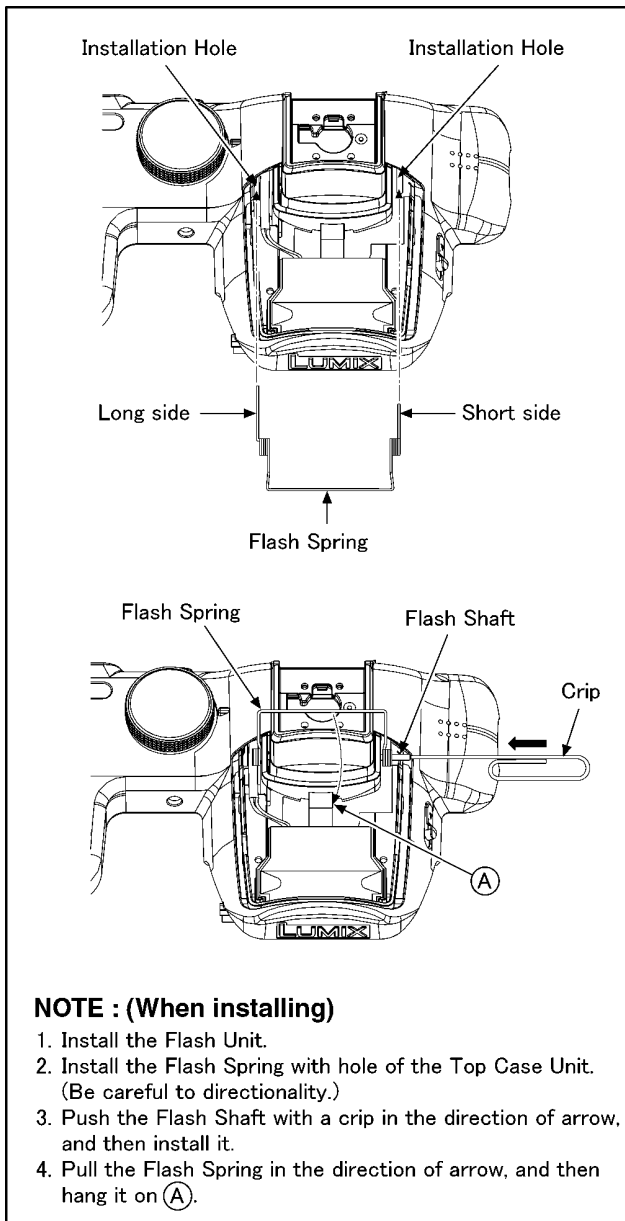

Fig. D22

### 8.3.19. Removal of the Hot Shoe Unit

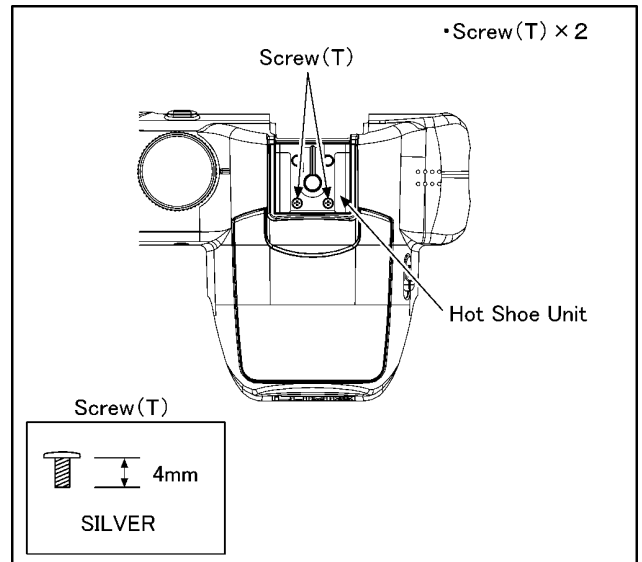

Fig. D23

## 8.4. Disassembly Procedure for the Lens

### NOTE: When Disassembling and Assembling for the Lens

- To minimize the possibility of the CCD being dirt, perform disassemble and/or assemble under the condition of the CCD is being mounted.  
Disassembling procedures for the CCD unit, refer to item 8.6.
- Take care that the dust and dirt are not entered into the lens.  
In case of the dust is putted on the lens, blow off them by airbrush.
- Do not touch the surface of lens.
- Use lens cleaning KIT (BK)(VFK1900BK).
- Apply the grease (VFK1829) to the point where is shown to "Grease apply" in the figure.  
When the grease is applied, use a toothpick and apply thinly.

### 8.4.1. Removal of the Lens FPC Unit

- Remove the solders (4 points).
- Remove the lock (8 points).
- Unscrew the 4 screws (A).
- Remove the Lens FPC unit.

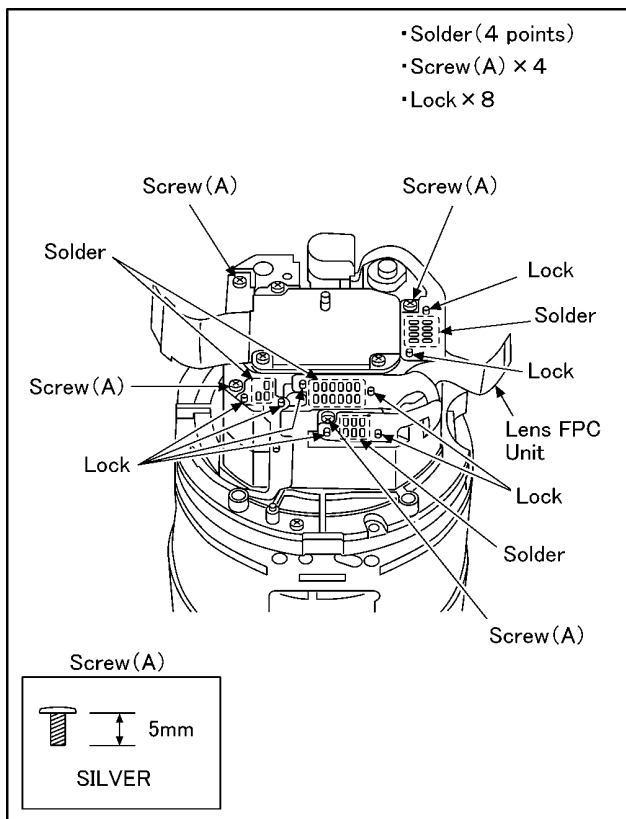

## 8.4.2. Removal of the Decoration Ring

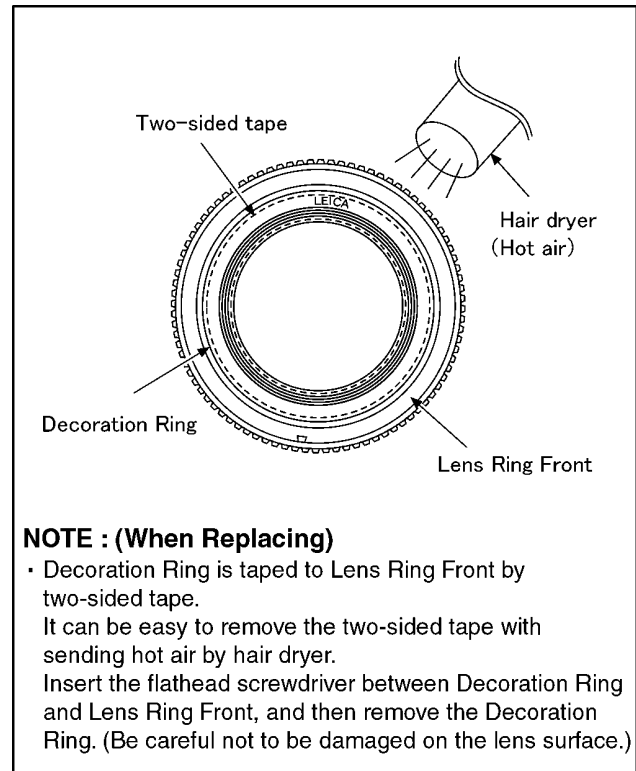

## 8.4.3. Removal of the Lens Ring Front and Zoom Ring Unit

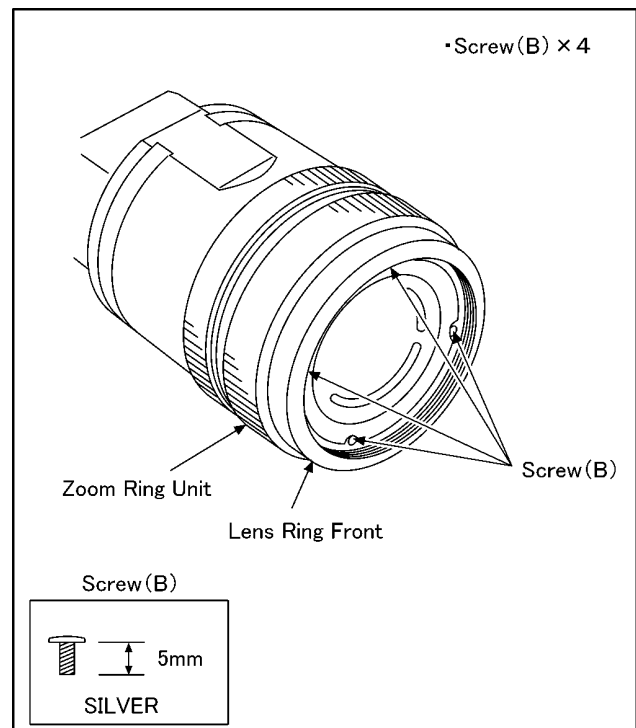



### 8.4.4. Removal of the Master Flange Unit, 1st Lens Frame Cushion and Lens Ring Base

•Screw (C) × 3  
•Locking tab × 3  
•1st Lens Frame Cushion

Screw (C)

Locking tab

Zoom Drive Pin

Locking tab

Master Flange Unit

1st Lens Frame Cushion

Lens Ring Base

**NOTE : (When Replacing)**

1. Remove the 3 screws (C), the Master Flange Unit is turned counterclockwise and the unlock the Locking tab ①, and then remove it to above ② direction. (Confirm the Zoom Drive Pin is in the groove of the Master Flange Unit.)
2. Remove the Lens Ring Base.

Screw (C)

### 8.4.5. Removal of the Zoom Encoder Unit

•Lock × 3  
•Screw (D) × 1

Zoom Encoder Unit

Lock

Screw (D)

Lock

Lock

**NOTE : (When Replacing)**

- When remove the Zoom Encoder Unit, Be careful not to damage the Zoom Encoder Flex.

Screw (D)

### 8.4.6. Removal of the Focus Motor Unit

•Screw (E) × 2  
•Lock × 2

Screw (E)

Lock

Focus Motor Unit

Screw (E)

### 8.4.7. Removal of the Master Flange

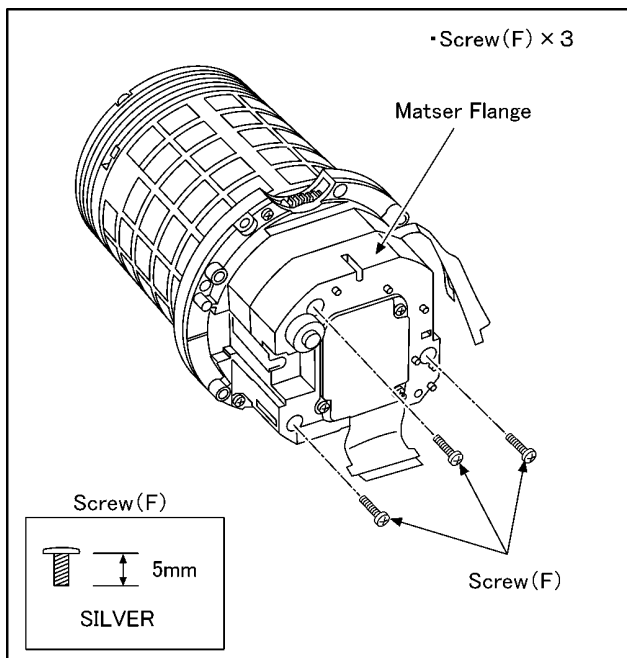

### 8.4.9. Removal of the Inside Frame

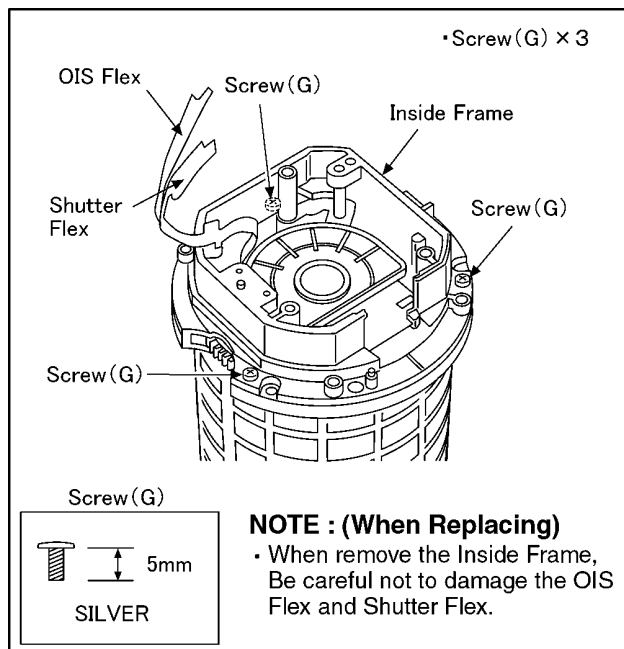

### 8.4.8. Removal of the 5th Lens Frame Unit and F Guide Pole L/S

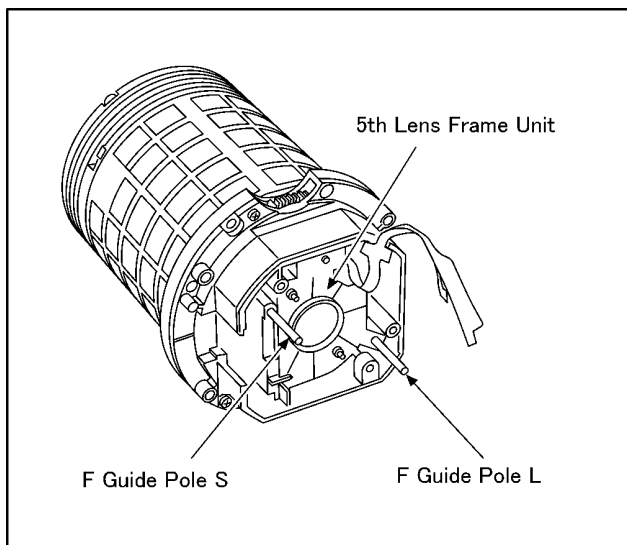

### 8.4.10. Removal of the 4th Lens Frame Unit

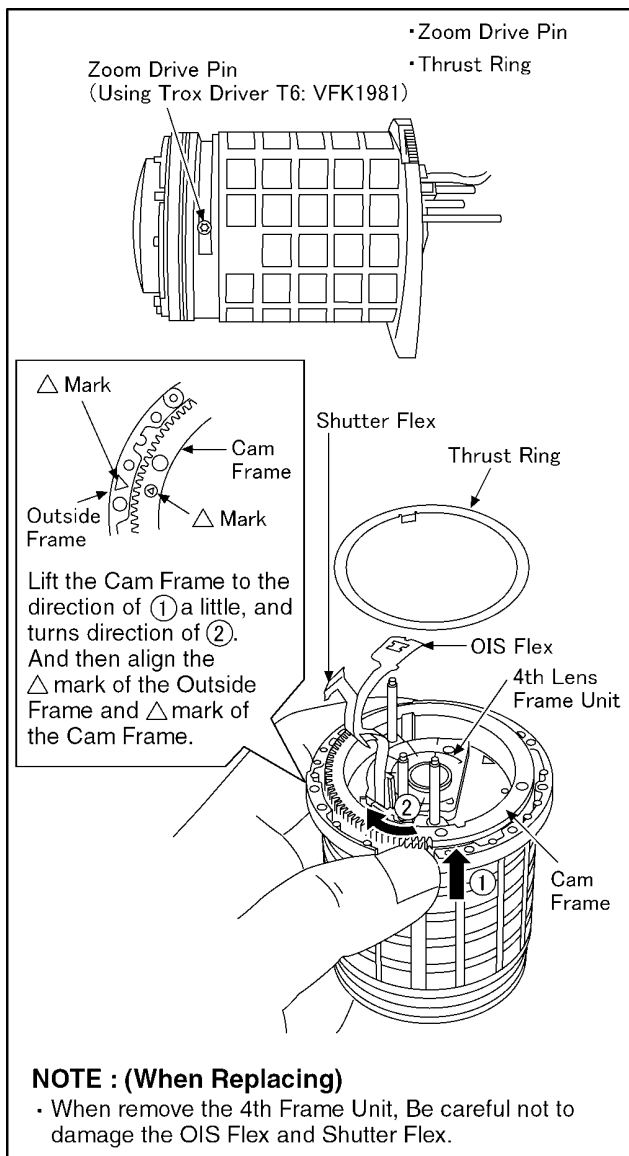

### 8.4.11. Removal of the 3rd Lens Frame Unit

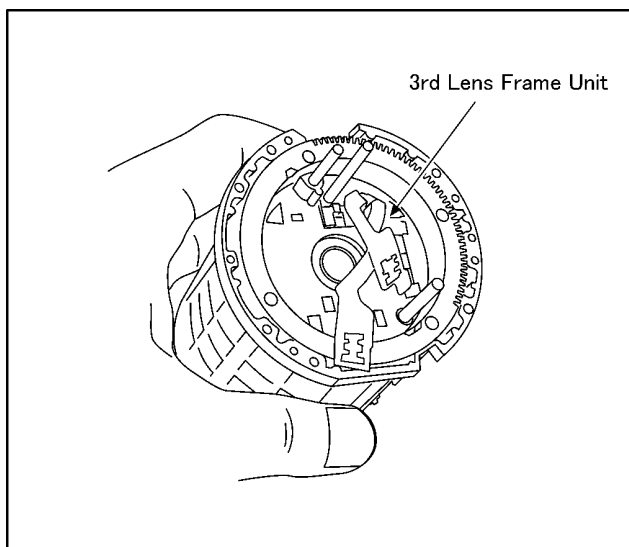

### 8.4.12. Removal of the 2nd Lens Frame Unit

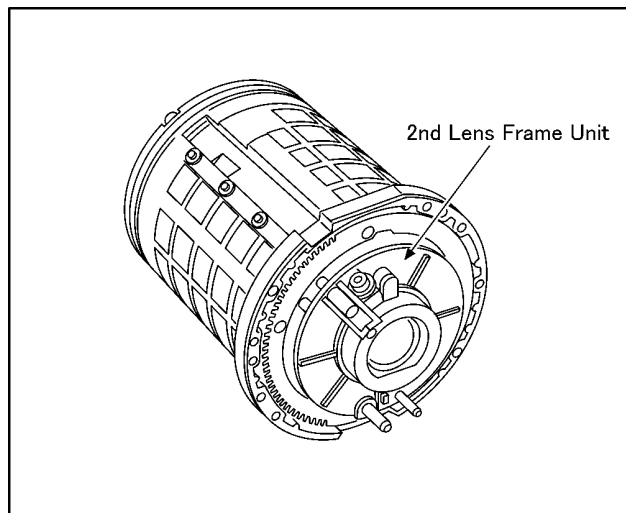

### 8.4.13. Removal of the Cam Frame Unit and Guide Pole

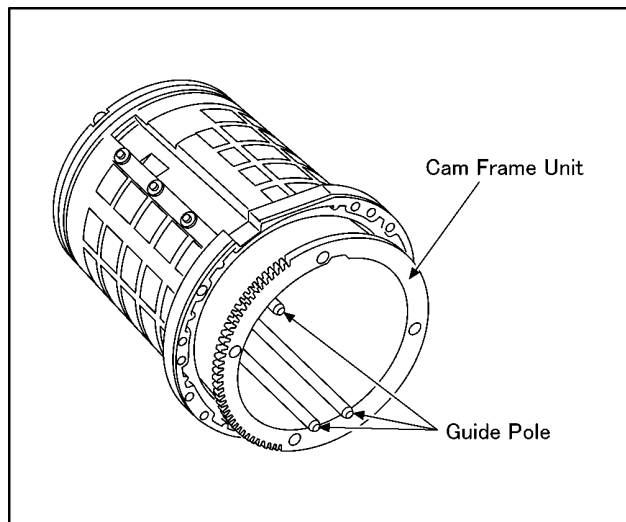

### 8.4.14. Removal of the 1st Lens Frame Unit

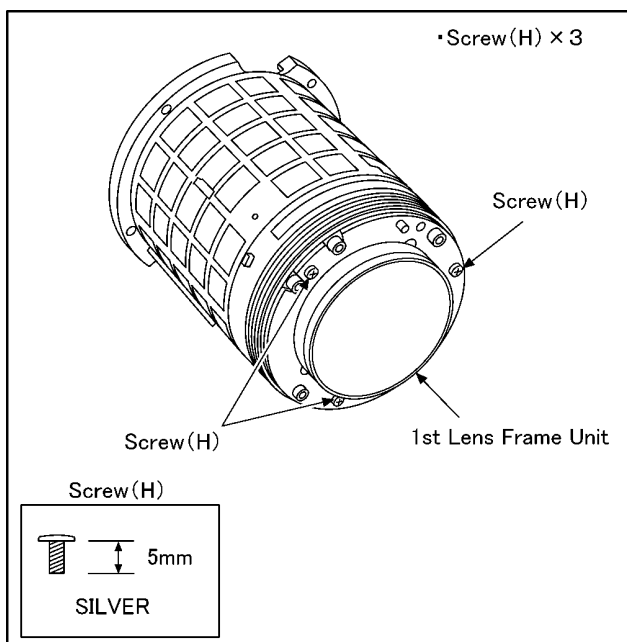

## 8.5. Assembly Procedure for the Lens

### 8.5.1. Assembly for the 1st Lens Frame Unit

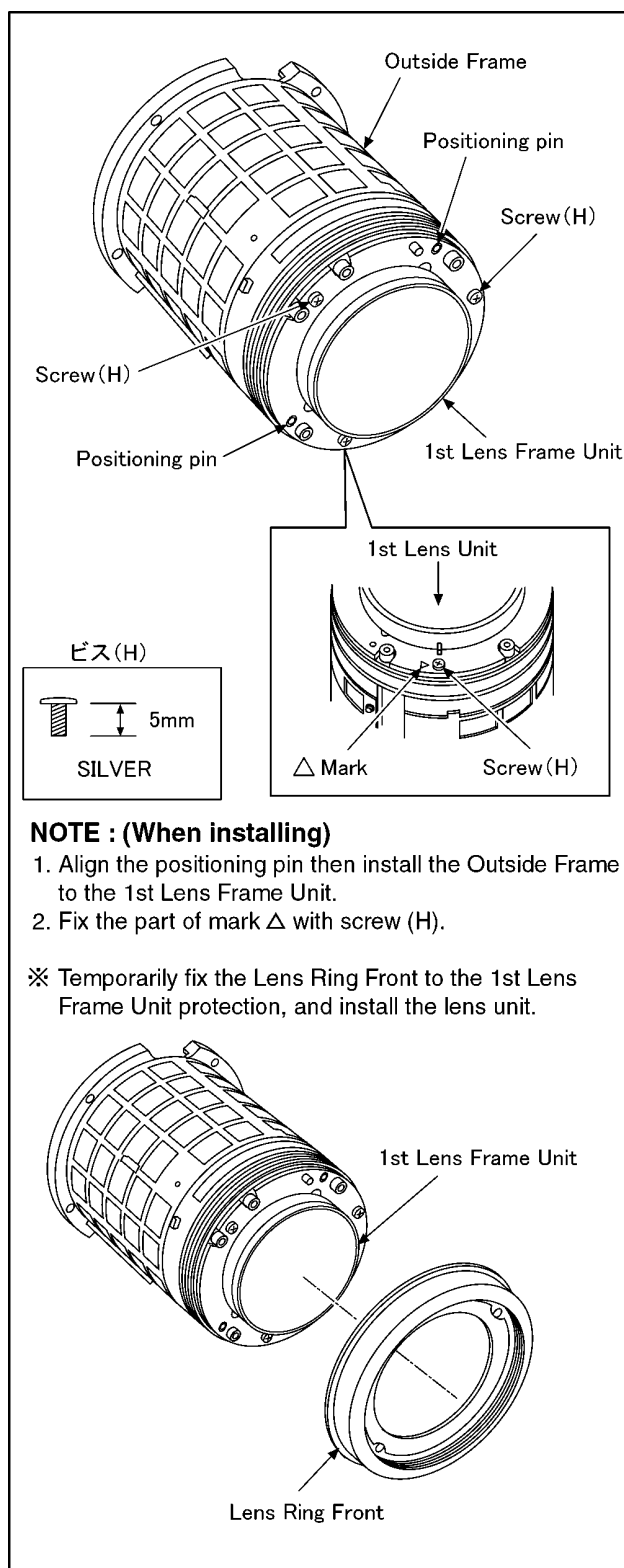

### 8.5.2. Assembly for the Guide Pole and Cam Frame Unit

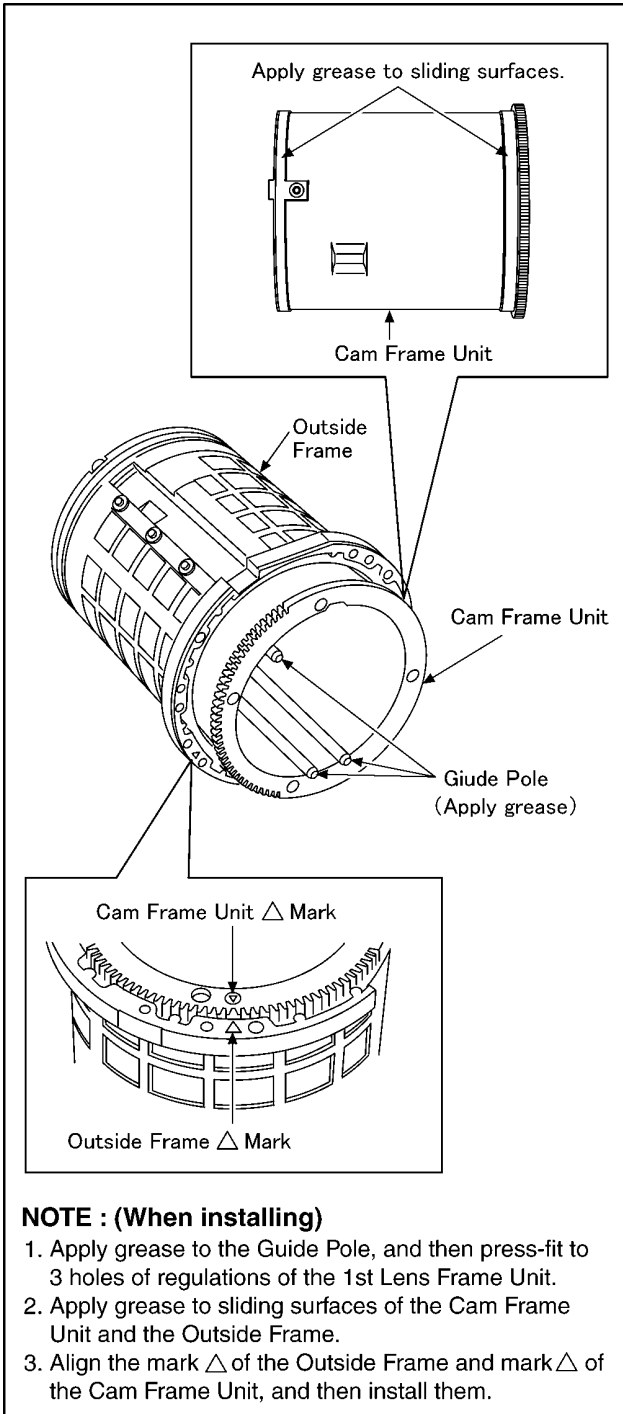

### 8.5.3. Assembly for the 2nd Lens Frame Unit

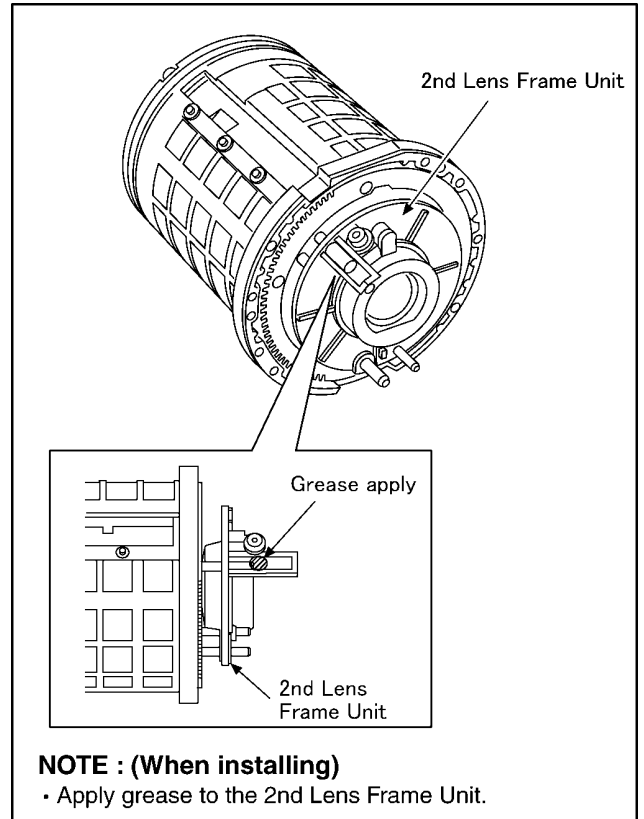

### 8.5.4. Assembly for the 3rd Lens Frame Unit

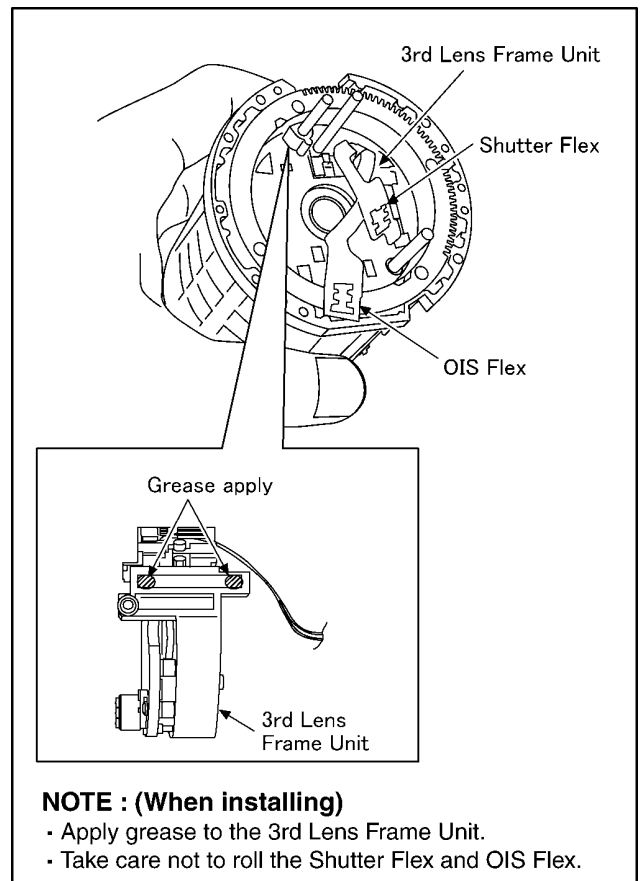

### 8.5.5. Assembly for the 4th Lens Frame Unit and Thrust Ring

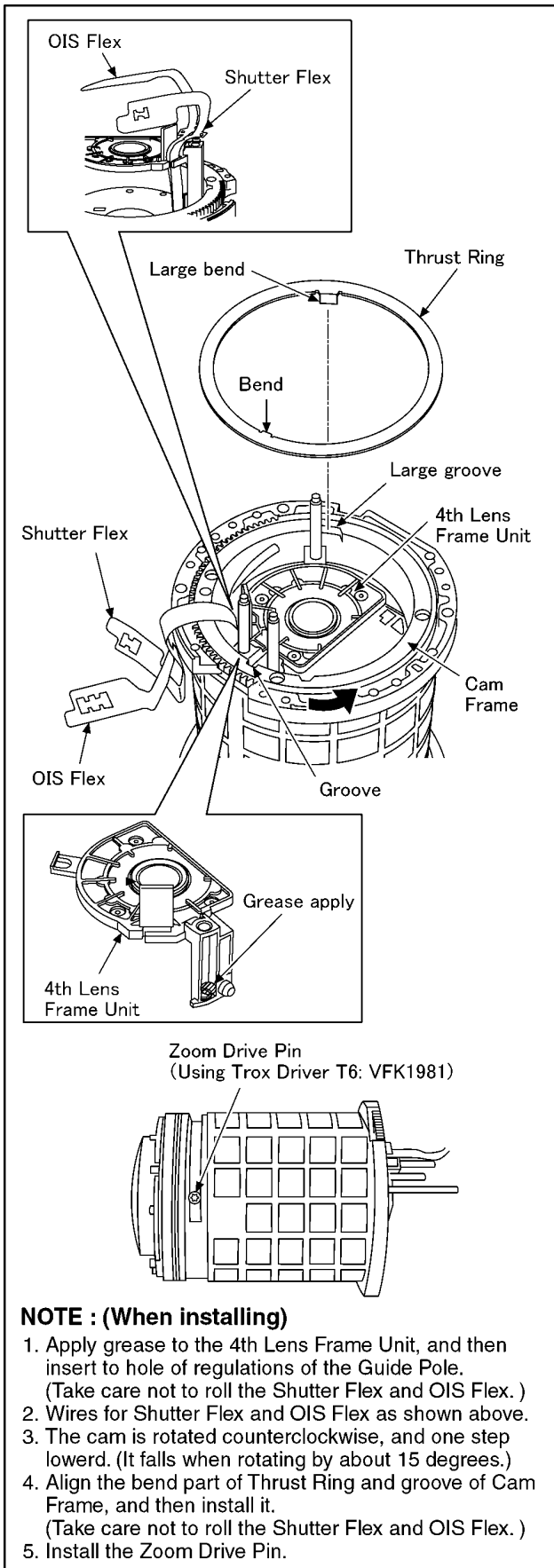

### 8.5.6. Assembly for the Inside Frame

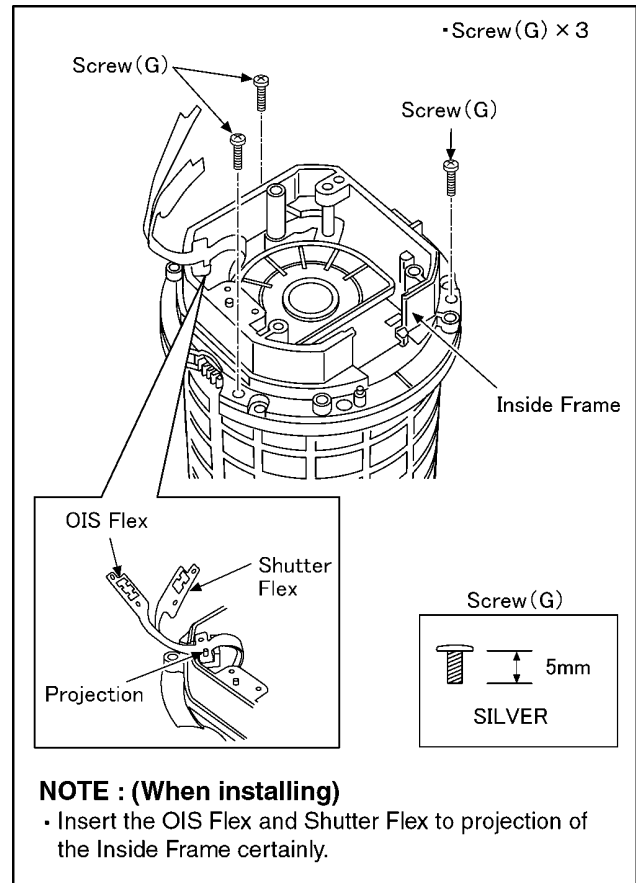

### 8.5.7. Assembly for the 5th Lens Frame Unit and F Guide Pole L/S

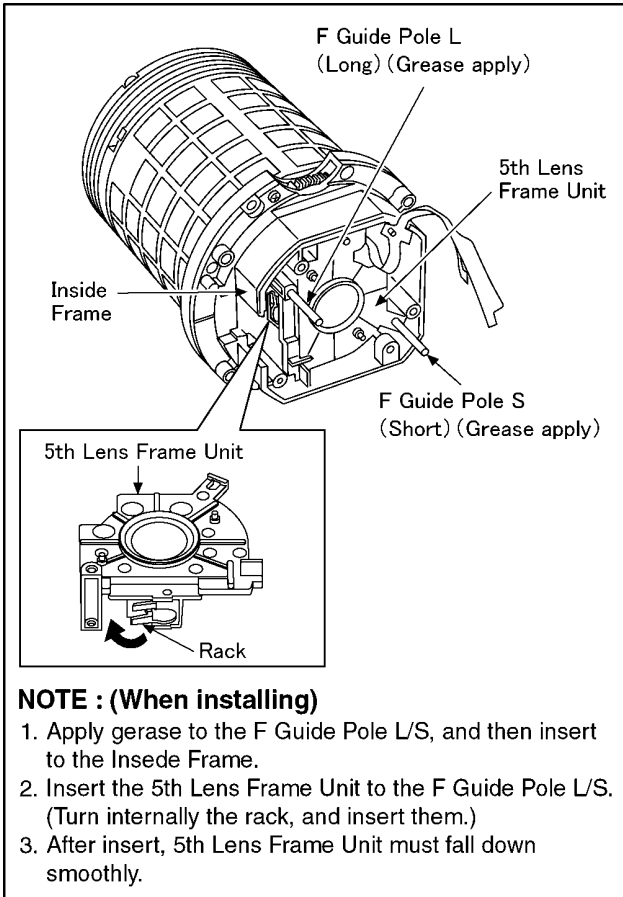

### 8.5.8. Assembly for the Master Frange

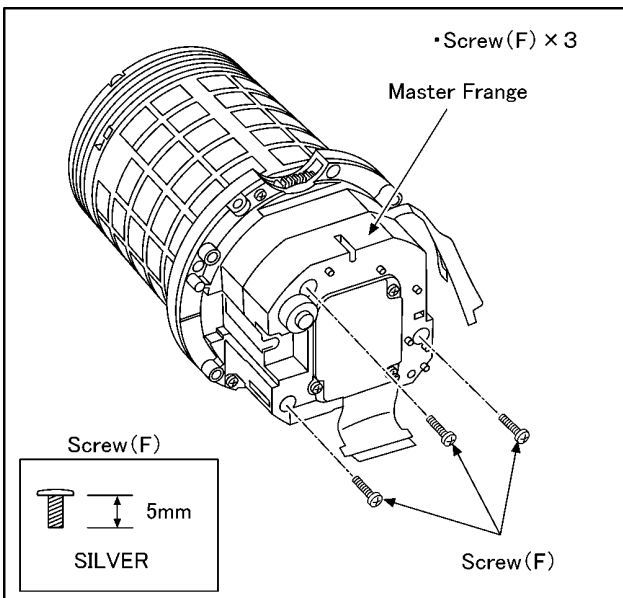

### 8.5.9. Assembly for the Focus Motor Unit

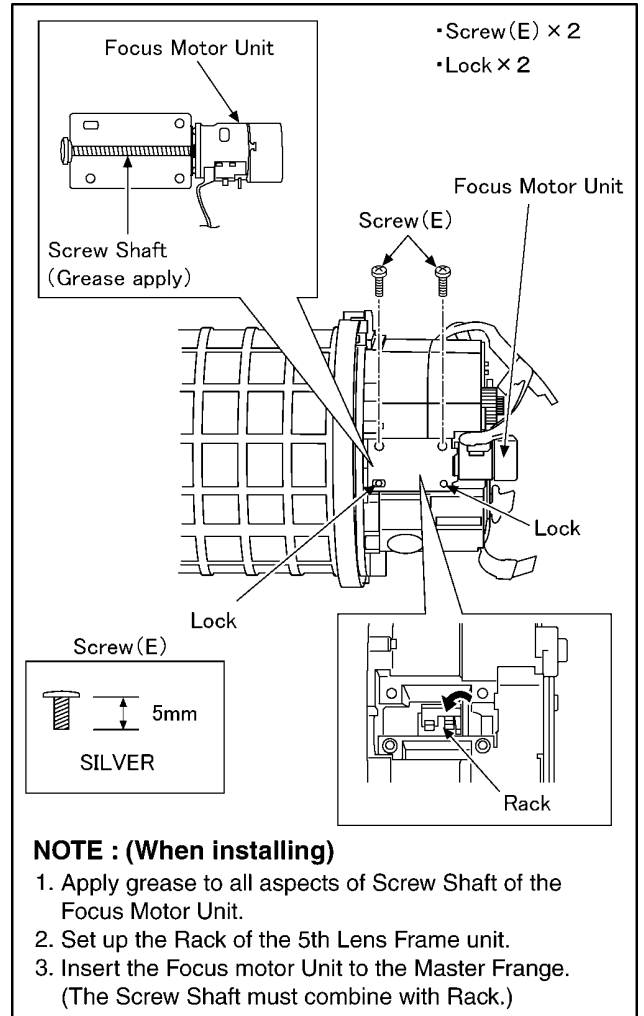

### 8.5.10. Assembly for the Zoom Encoder Unit

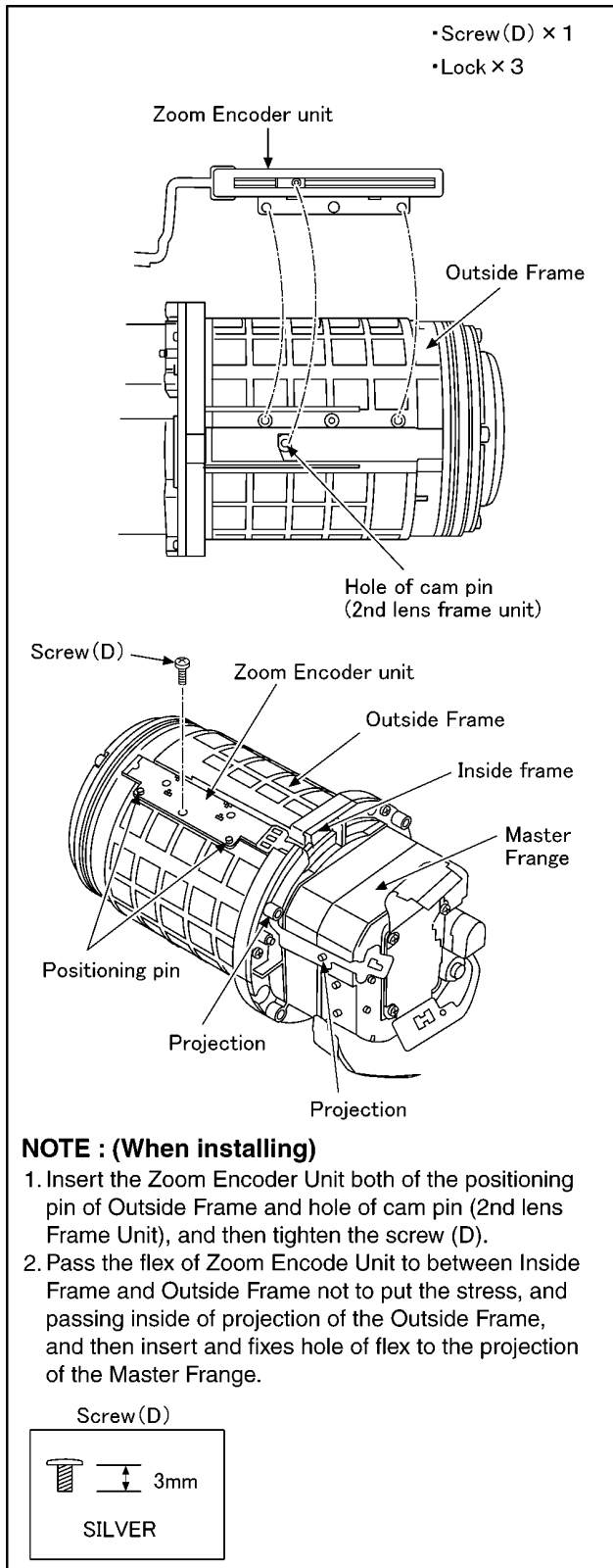

### 8.5.11. Assembly for the Lens Ring Base Master Frange Unit and 1st Lens Frame Cushion

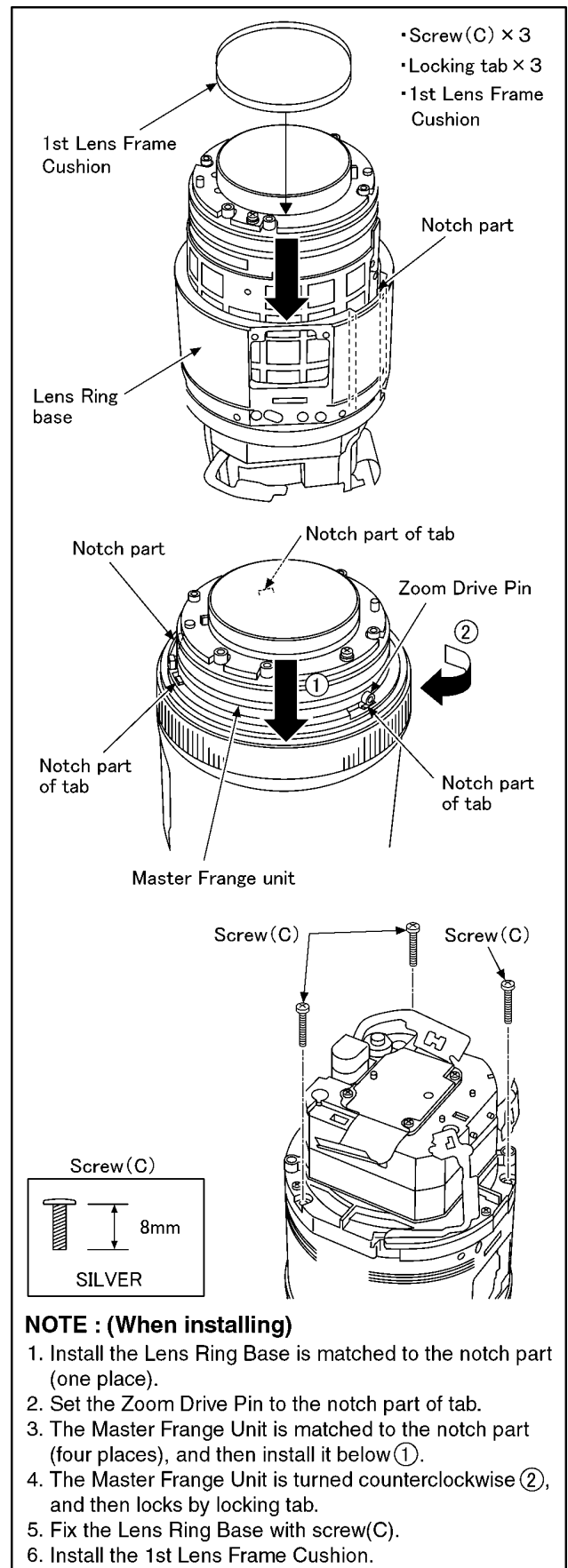



### 8.5.12. Assembly for the Lens Ring Front and Zoom Ring Unit

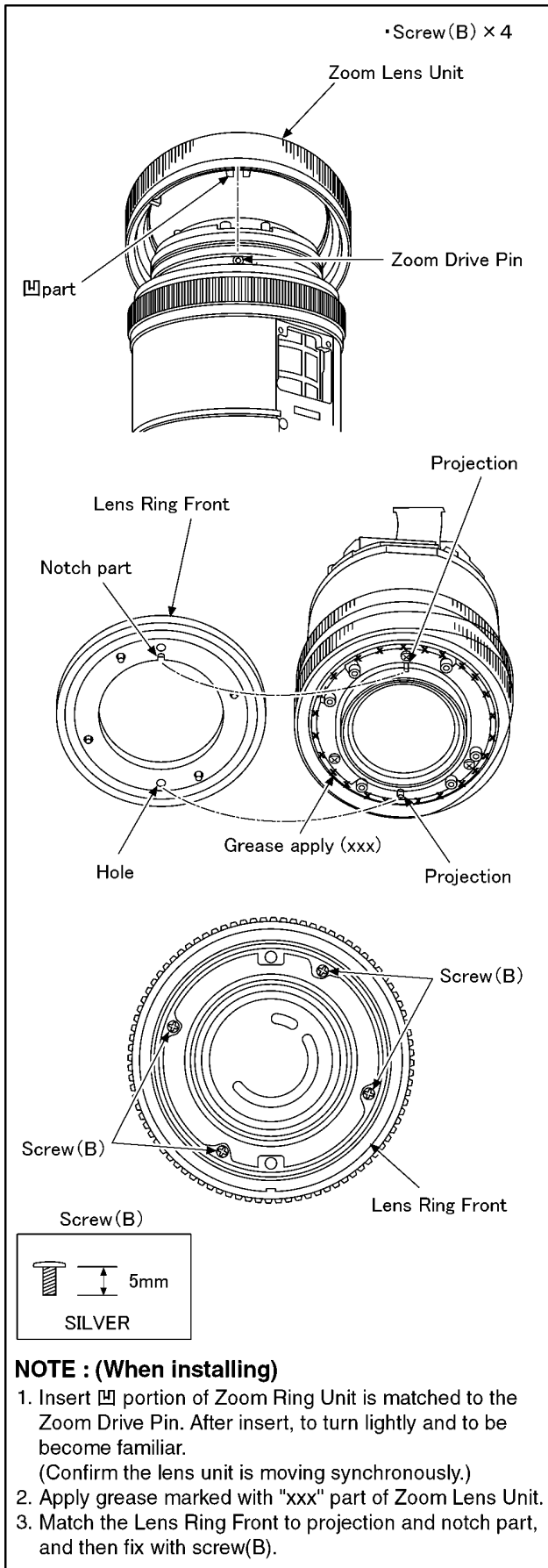

### 8.5.13. Assembly for the Decoration Ring

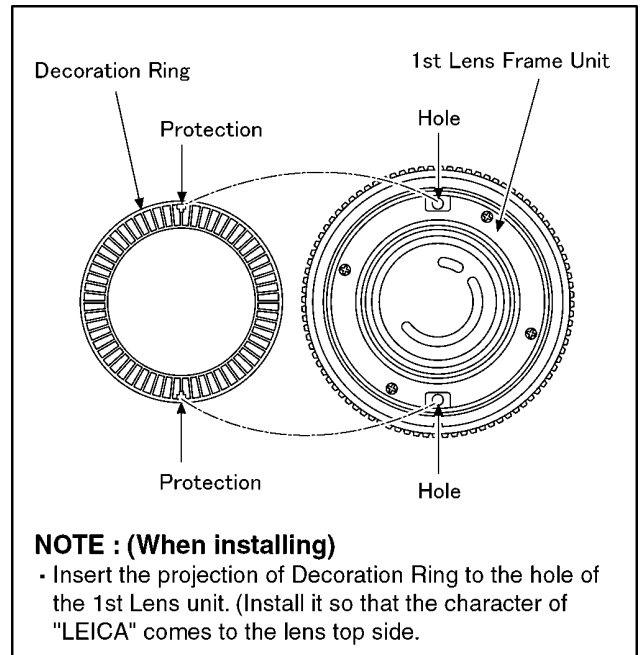

### 8.5.14. Assembly for the Lens FPC Unit

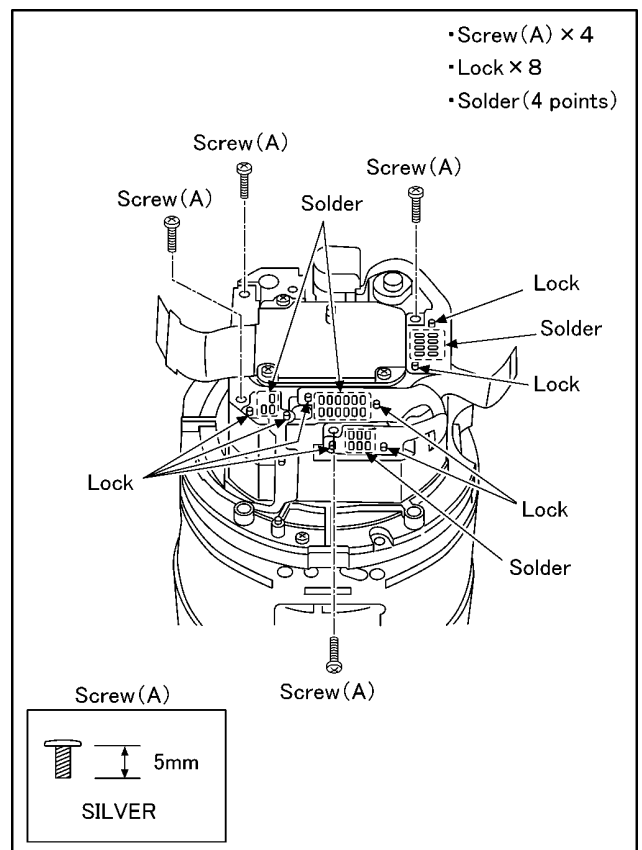

## 8.6. Removal of the CCD

To prevent the CCD unit from catching the dust and dirt, do not remove the CCD unit except for replacing.

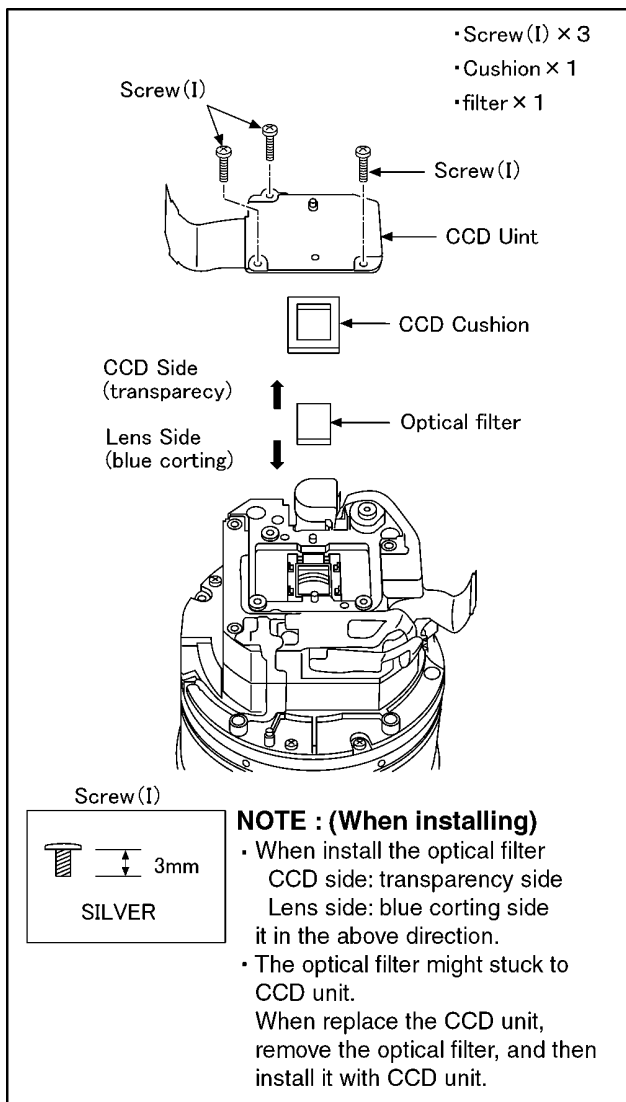

# 9 Measurements and Adjustments

## 9.1. Adjustment Procedures

The relation between Replaced part and Necessary Adjustment is shown in the following table.

When concerned part is replaced, be sure to achieve the necessary adjustment(s).

As for Adjustment condition/procedure, consult the "Adjustment Manual" which is available in Adjustment software.

The Adjustment software is available at "TSN Website", therefore, access to "TSN Website" at "Support Information from NWBG/VDBG-PAVC".

**NOTE:**

After adjustments have been terminated, make sure to achieve "INITIAL SETTINGS".

Adjustment Item		Replaced Part					
		Main P.C.B.	VENUS (IC6001)	Flash-ROM (IC6003)	Lens Part (Excluding CCD)	CCD Unit	EVF Unit
Camera Section	OIS hall element adjustment (OIS)	○	○	○	○		
	Back focus adjustment (BF)	○	○	○	○		
	Shutter adjustment (SHT)	○	○	○	○	○	
	ISO sensitivity adjustment (ISO)	○	○	○	○	○	
	AWB adjustment High brightness coloration inspection (WBL)	○	○	○	○	○	
	CCD white scratch compensation (WKI)	○	○	○		○	
EVF Section	EVF Rank Setting (EVF)	○		○			○

**NOTE:**

\*There is no LCD adjustment in this model.

\*There is no CCD Black scratch compensation adjustment (BKI) in this model.

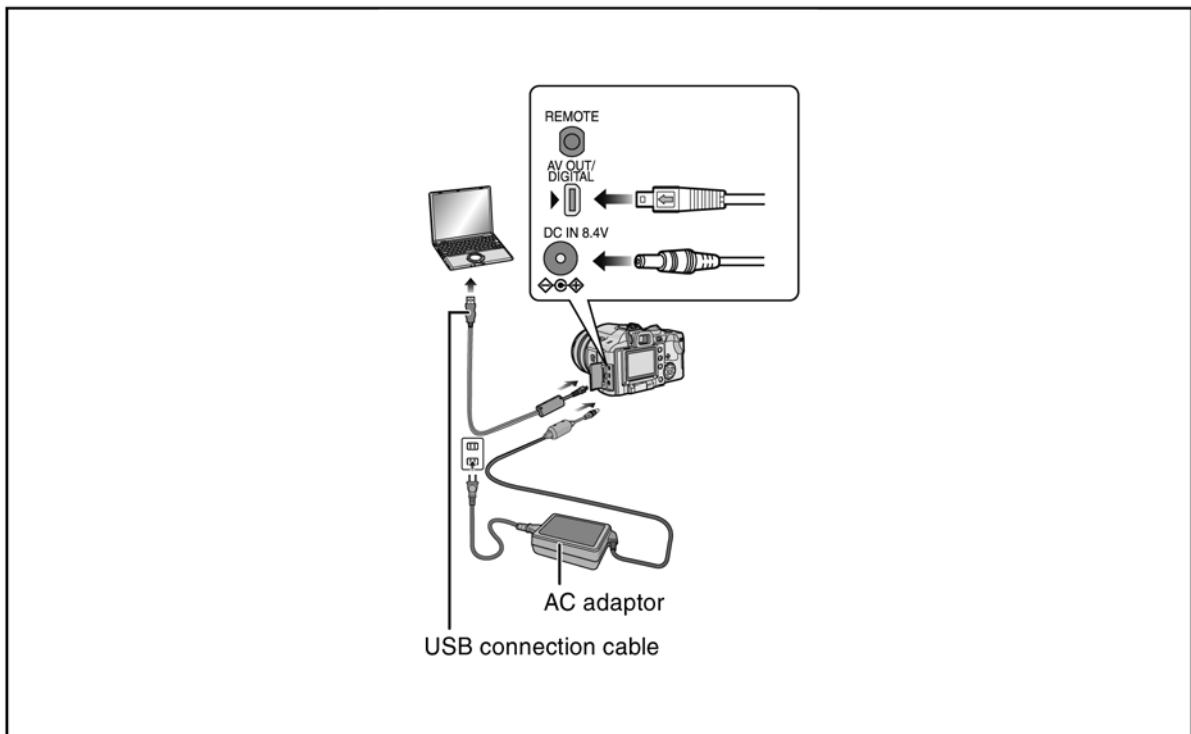

# 10 Maintenance

## 10.1. Cleaning Lens, Viewfinder and LCD Panel

Do not touch the surface of lens, Viewfinder and LCD Panel with your hand.

When cleaning the lens, use air-Blower to blow off the dust.

When cleaning the LCD Panel, dampen the lens cleaning paper with lens cleaner, and the gently wipe the their surface.

**Note:**

A lens cleaning paper and lens cleaner are available at local camera shops and market place.

# Service Manual

---

## Diagrams and Replacement Parts List

### Digital Camera

- |             |            |
|-------------|------------|
| DMC-FZ50PP  | DMC-FZ50GC |
| DMC-FZ50PL  | DMC-FZ50GD |
| DMC-FZ50EB  | DMC-FZ50GK |
| DMC-FZ50EE  | DMC-FZ50GN |
| DMC-FZ50EF  | DMC-FZ50GT |
| DMC-FZ50EG  | DMC-FZ50SG |
| DMC-FZ50EGM |            |

Vol. 1  
 Colour  
 (S).....Silver Type  
 (K).....Black Type

### Table of contents

S1. About Indication of The Schematic Diagram.....	S-1	S5. Print Circuit Board.....	S-9
S1.1. Important Safety Notice.....	S-1	S5.1. Flash P.C.B. ....	S-9
S2. Voltage Chart .....	S-2	S5.2. AF Assist P.C.B. ....	S-9
S2.1. Flash P.C.B. ....	S-2	S5.3. LCD IF P.C.B.....	S-10
S3. Block Diagram.....	S-3	S5.4. CCD Flex P.C.B.....	S-11
S3.1. Overall Block Diagram .....	S-3	S5.5. MIC Flex P.C.B.....	S-12
S4. Schematic Diagram.....	S-4	S5.6. Lens Flex P.C.B.....	S-13
S4.1. Interconnection Diagram .....	S-4	S6. Replacement Parts List.....	S-15
S4.2. Flash Schematic Diagram .....	S-5	S7. Exploded View .....	S-22
S4.3. AF Assist Schematic Diagram .....	S-5	S7.1. Frame and Casing Section (1) .....	S-22
S4.4. LCD IF Schematic Diagram .....	S-6	S7.2. Frame and Casing Section (2) .....	S-23
S4.5. CCD Flex Schematic Diagram .....	S-6	S7.3. Frame and Casing Section (3) .....	S-24
S4.6. MIC Flex Schematic Diagram .....	S-7	S7.4. Packing Parts and Accessories Section.....	S-25
S4.7. Lens Flex Schematic Diagram .....	S-8		

## S1. About Indication of The Schematic Diagram

### S1.1. Important Safety Notice

COMPONENTS IDENTIFIED WITH THE MARK  $\triangle$  HAVE THE SPECIAL CHARACTERISTICS FOR SAFETY. WHEN REPLACING ANY OF THESE COMPONENTS USE ONLY THE SAME TYPE.

- 1.Although reference number of the parts is indicated on the P.C.B. drawing and/or schematic diagrams, it is NOT mounted on the P.C.B. when it is displayed with "\$" mark.
- 2.It is only the "Test Round" and no terminal (Pin) is available on the P.C.B. when the TP (Test Point) indicated as "●" mark.
- 3.The voltage being indicated on the schematic diagram is measured in "Standard-Playback" mode when there is no specify mode is mentioned.
- 4.Although the voltage and waveform available on here is measured with standard frame, it may be differ from actual measurement due to modification of circuit and so on.
- 5.The voltage being indicated here may be include observational-error (deviation) due to internal-resistance and/or reactance of equipment. Therefore, handle the value indicated on here as reference.
- 6.Use the parts number indicated on the Replacement Parts List .
- 7.Indication on Schematic diagrams:

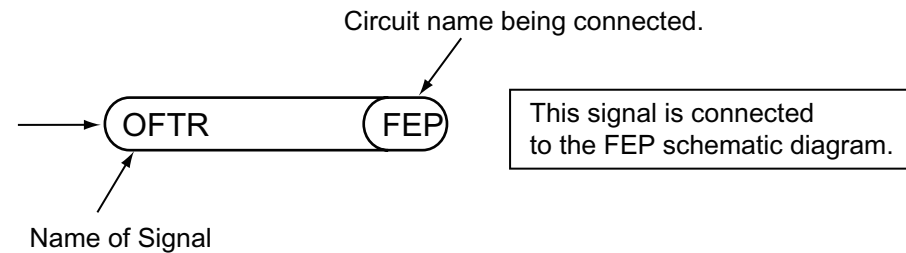

## S2. Voltage Chart

Note) Indicated voltage values are the standard values for the unit measured by the DC electronic circuit tester (high-impedance) with the chassis taken as standard.  
Therefore, there may exist some errors in the voltage values, depending on the internal impedance of the DC circuit tester.

### S2.1. Flash P.C.B.

REF No.	PIN No.	POWER ON
Q8104	1	7.7
Q8104	2	7.7
Q8104	3	0
Q8104	4	0
Q8104	5	7.7
Q8104	6	7.7
QR8101	1	0
QR8101	2	4.6
QR8101	3	0
QR8101	4	5
QR8101	5	4.6
QR8101	6	0
QR8102	E	0
QR8102	C	4.5
QR8102	B	0
QR8106	E	0
QR8106	C	0
QR8106	B	2.9

# S3. Block Diagram

## S3.1. Overall Block Diagram

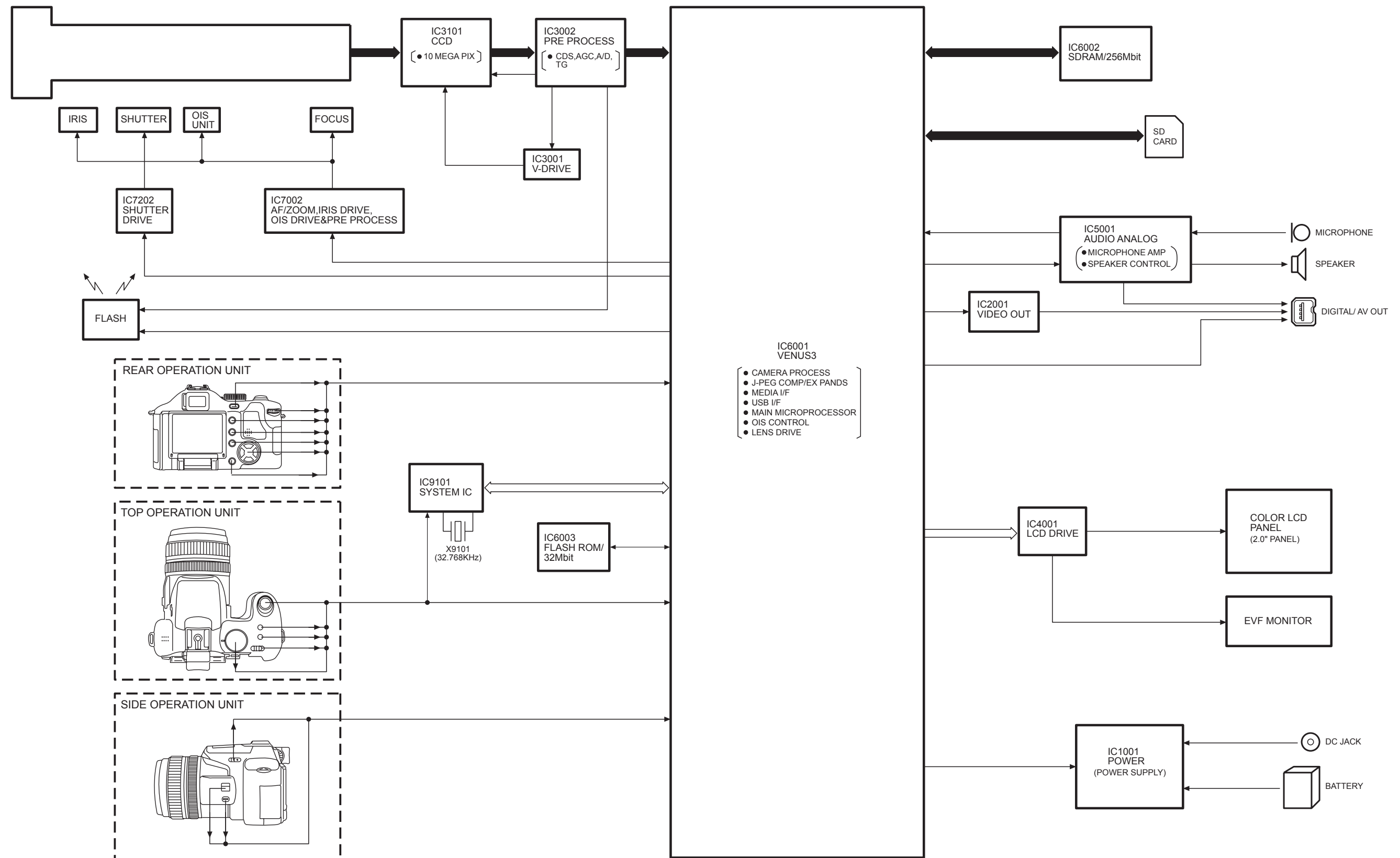

# S4. Schematic Diagram

## S4.1. Interconnection Diagram

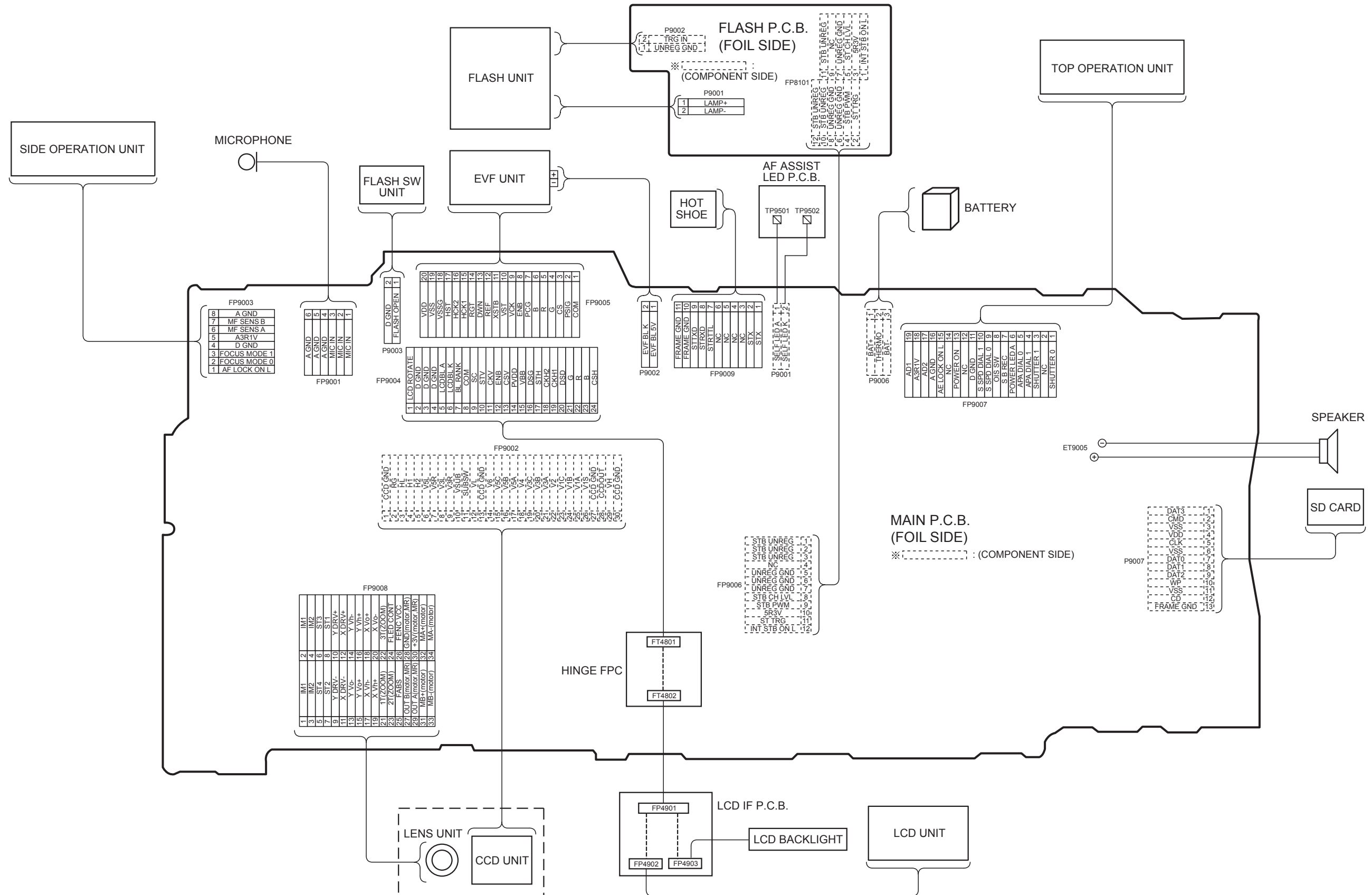



S4.2. Flash Schematic Diagram / S4.3. AF Assist Schematic Diagram

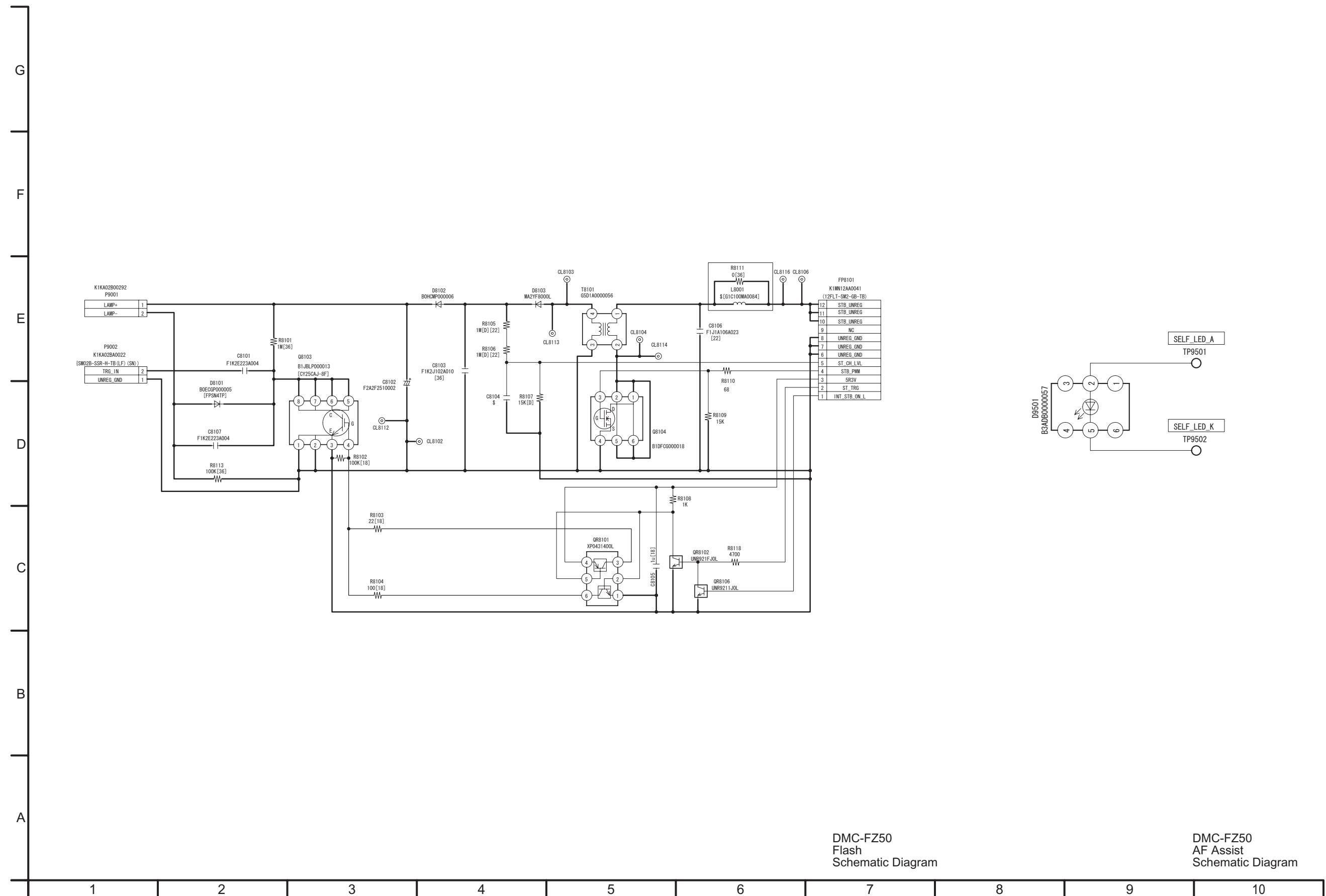

DMC-FZ50  
Flash  
Schematic Diagram

DMC-FZ50  
AF Assist  
Schematic Diagram

S4.4. LCD IF Schematic Diagram / S4.5. CCD Flex Schematic Diagram

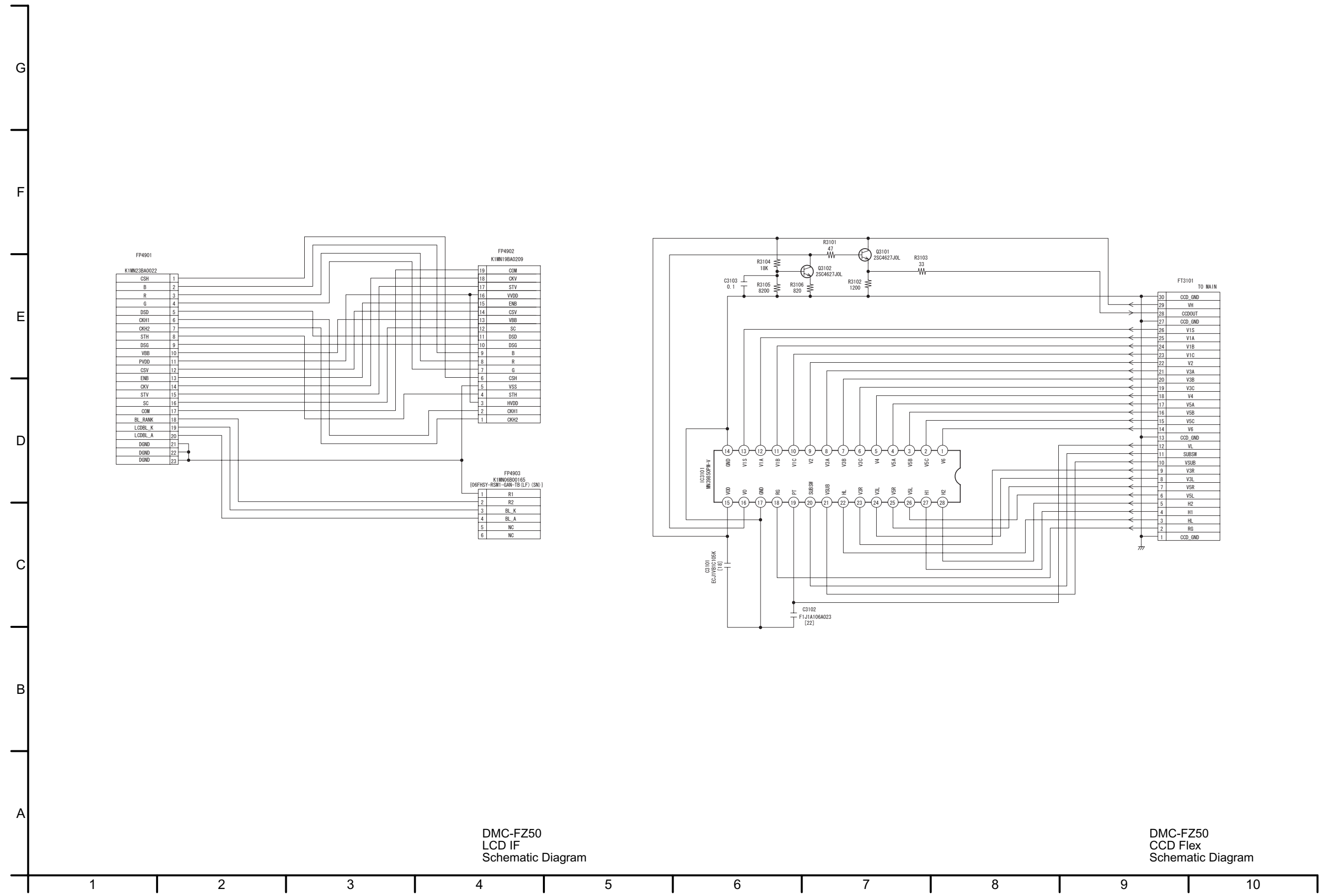

DMC-FZ50  
LCD IF  
Schematic Diagram

DMC-FZ50  
CCD Flex  
Schematic Diagram

# S4.6. MIC Flex Schematic Diagram

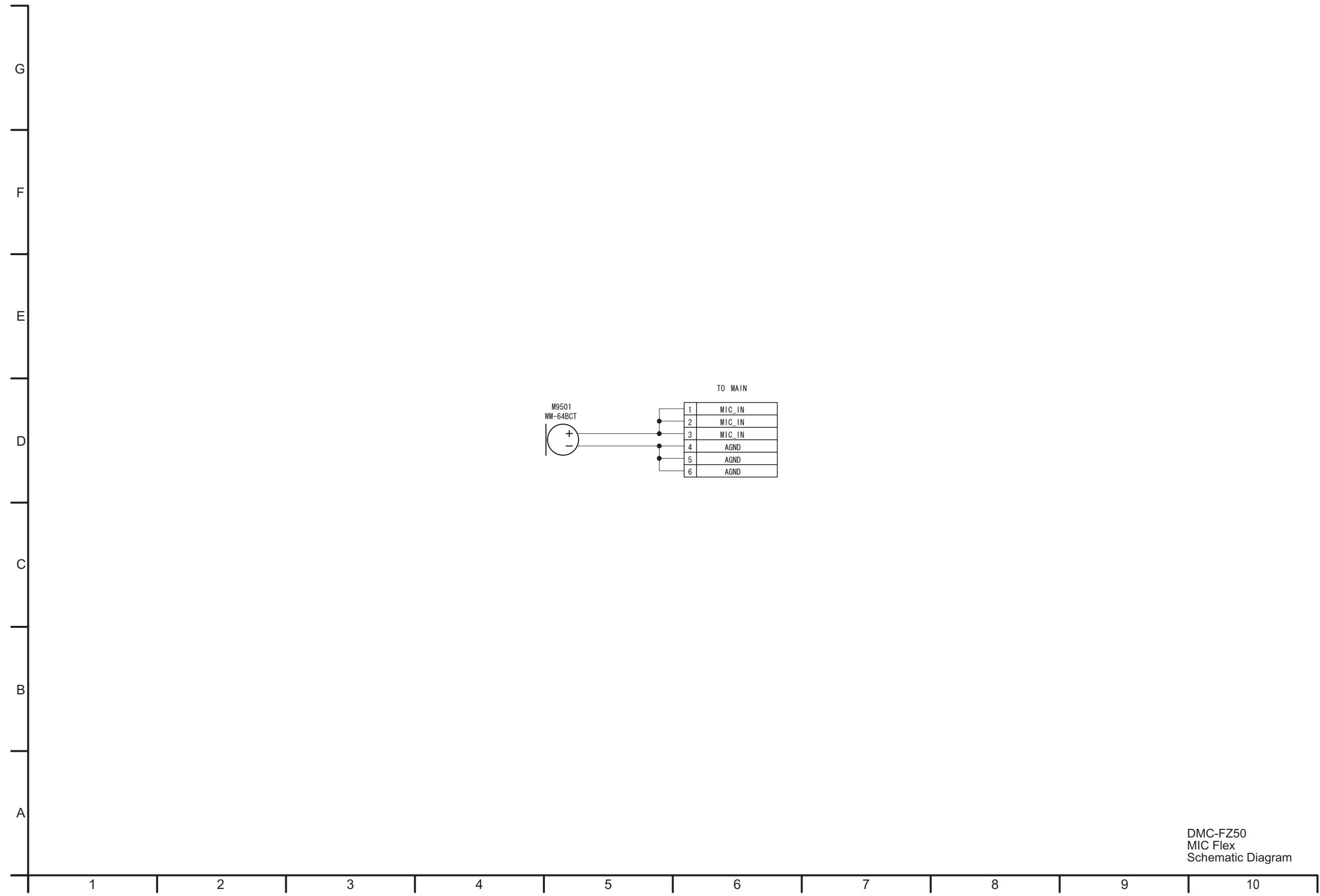

DMC-FZ50  
MIC Flex  
Schematic Diagram

# S4.7. Lens Flex Schematic Diagram

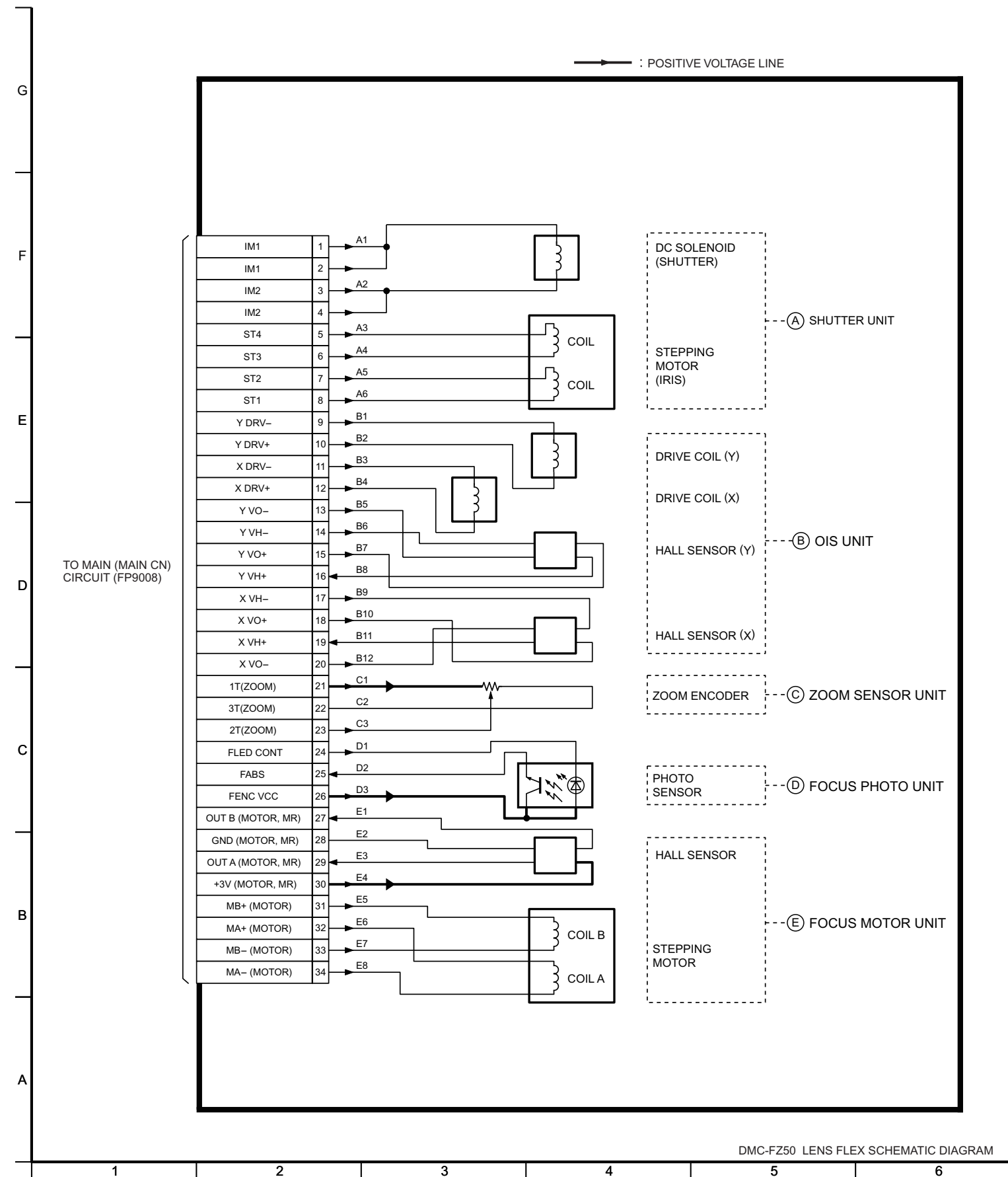

# S5. Print Circuit Board

## S5.1. Flash P.C.B. / S5.2. AF Assist P.C.B.

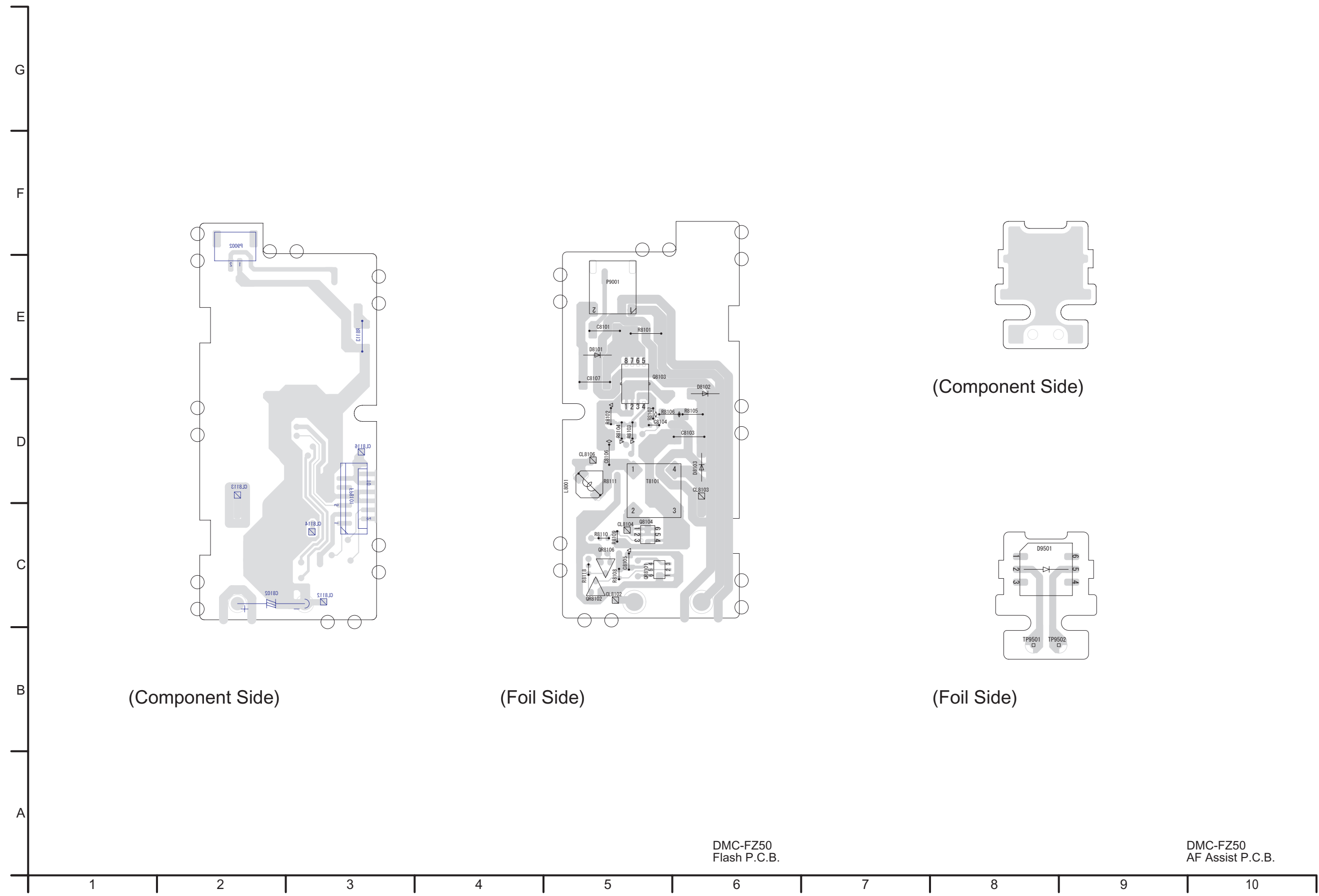

(Component Side)

(Foil Side)

(Component Side)

(Foil Side)

DMC-FZ50  
Flash P.C.B.

DMC-FZ50  
AF Assist P.C.B.

S5.3. LCD IF P.C.B.

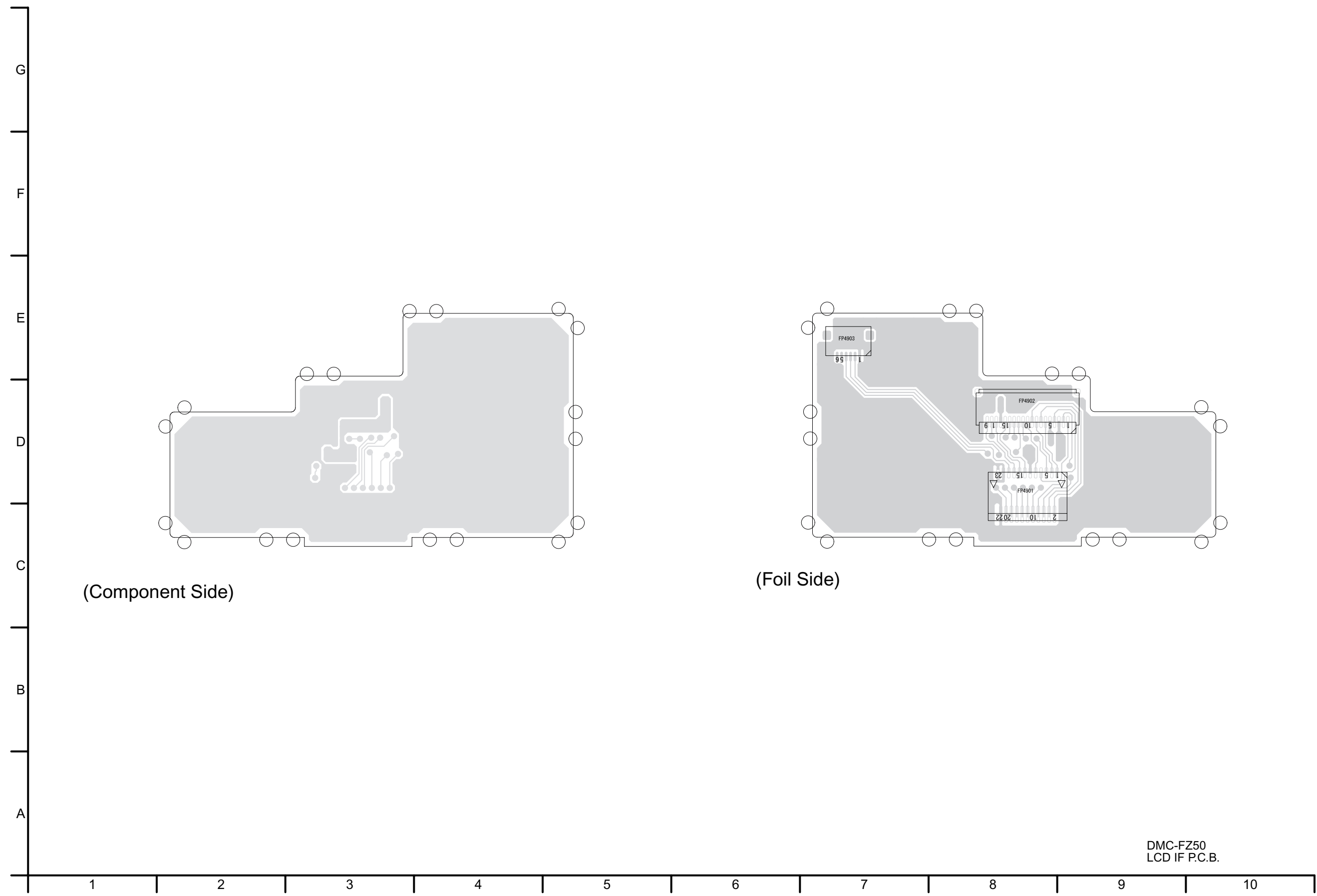

(Component Side)

(Foil Side)

DMC-FZ50  
LCD IF P.C.B.

S5.4. CCD Flex P.C.B.

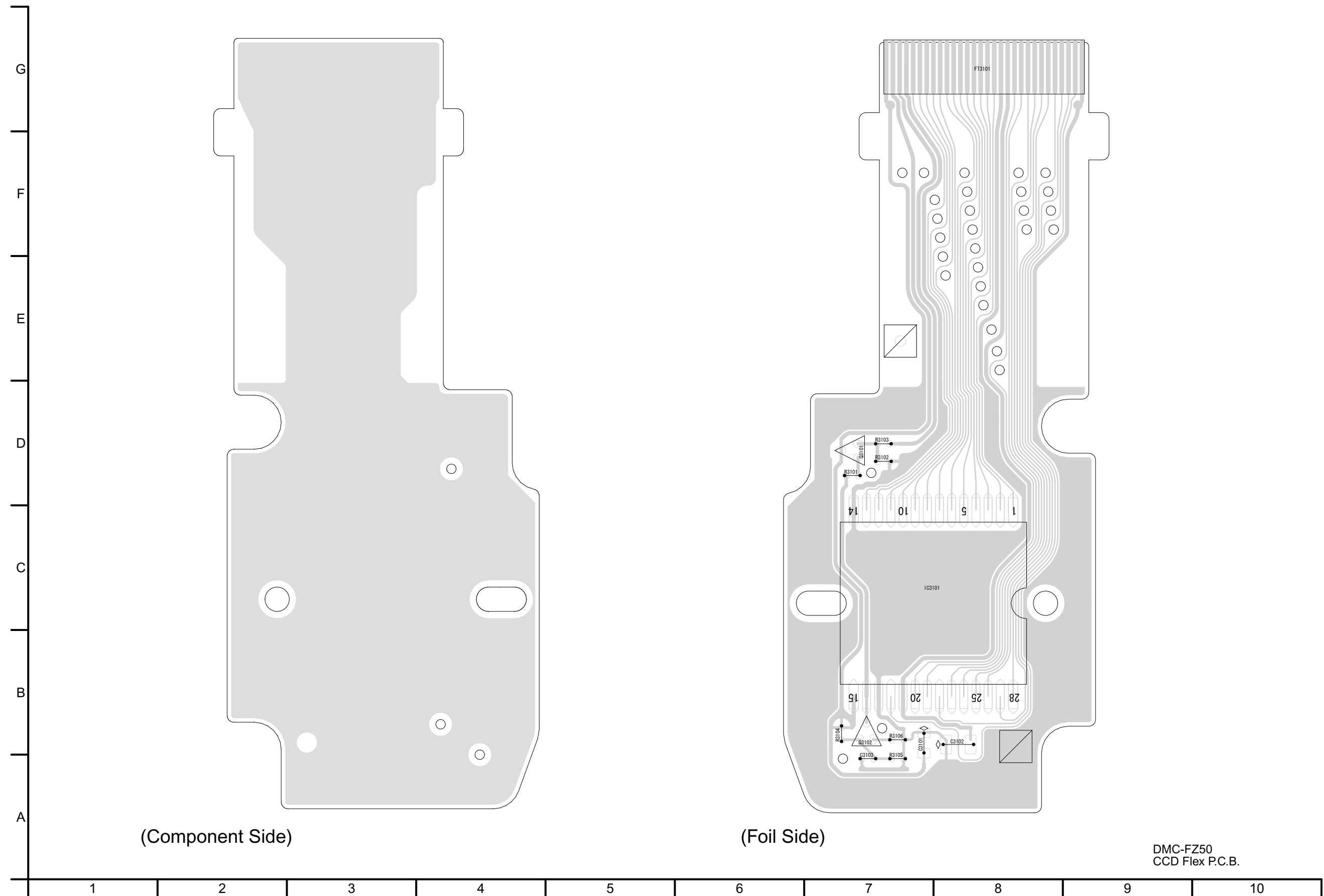

(Component Side)

(Foil Side)

DMC-FZ50  
CCD Flex P.C.B.

S5.5. MIC Flex P.C.B.

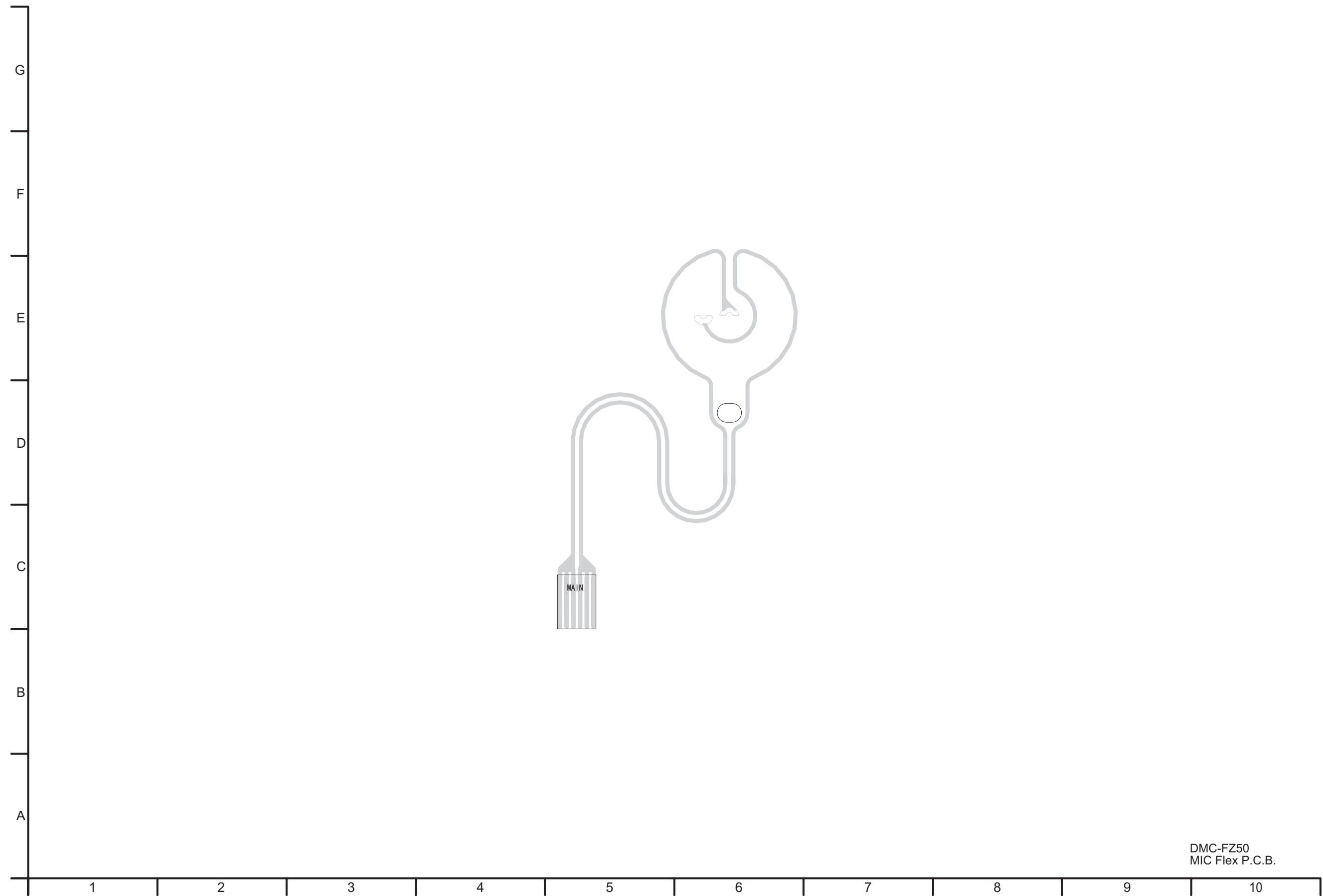

DMC-FZ50  
MIC Flex P.C.B.



S5.6. Lens Flex P.C.B.

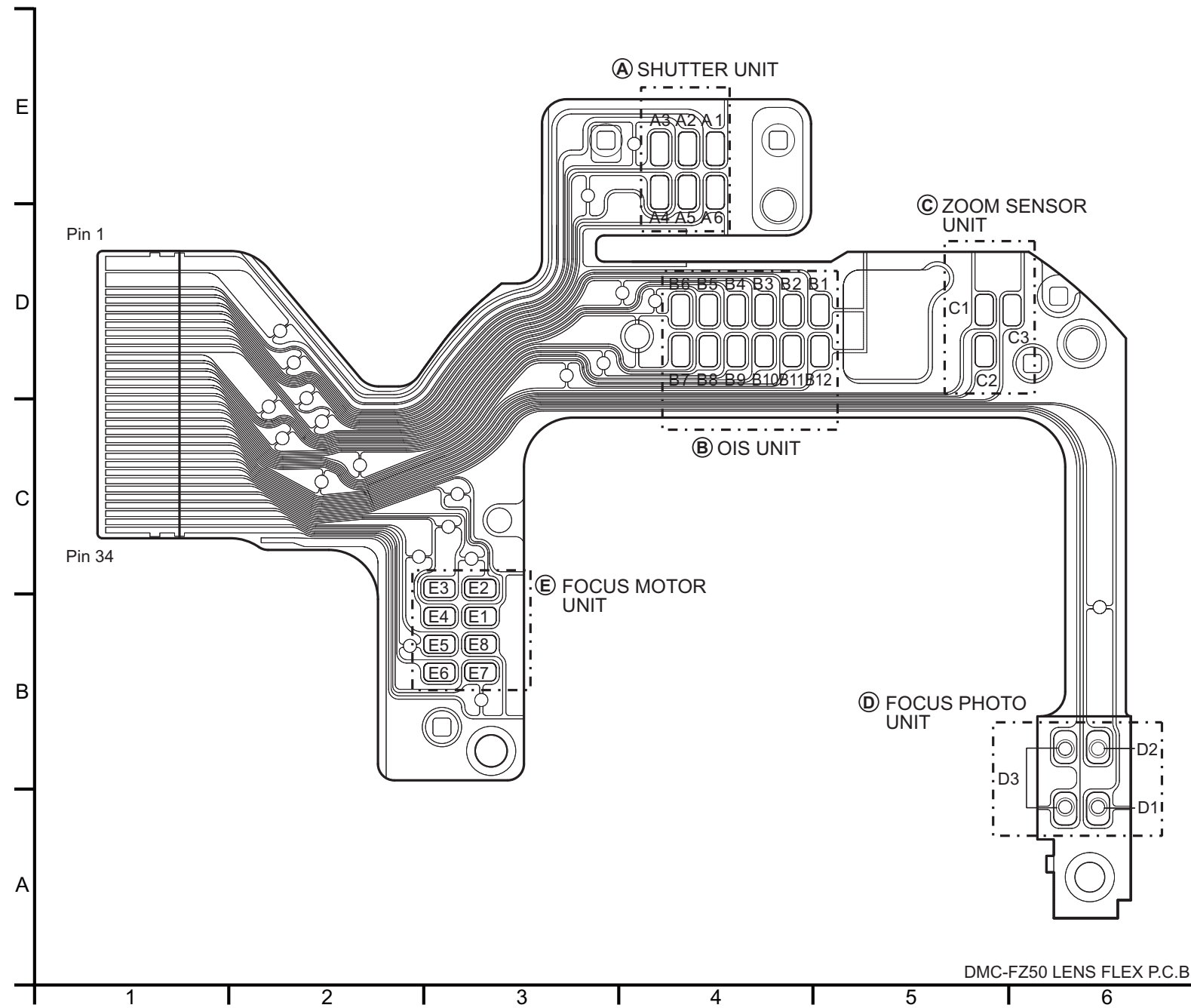



## S6. Replacement Parts List

- Note: 1.\* Be sure to make your orders of replacement parts according to this list.
2. IMPORTANT SAFETY NOTICE  
Components identified with the mark  $\triangle$  have the special characteristics for safety.  
When replacing any of these components, use only the same type.
3. Unless otherwise specified,  
All resistors are in OHMS, K=1,000 OHMS. All capacitors are in MICRO-FARADS (uf), P=uuF.
4. The marking (RTL) indicates the retention time is limited for this item. After the discontinuation of this assembly in production, it will no longer be available.

**E.S.D. standards for Electrostatically Sensitive Devices, refer to “PREVENTION OF ELECTROSTATIC DISCHARGE (ESD) TO ELECTROSTATICALLY SENSITIVE (ES) DEVICES” section.**

**Definition of Parts supplier:**

1. **Parts marked with [PAVC-CSG] in the remarks column are supplied from PAVC COMPANY CS Group (PAVC-CSG). Others are supplied from “PSEC-SAIJO”.**







DMC-FZ50EB-K/S,EF-K/S,EGMK/S,EG-K/S,PL-K/S,PP-K/S,EE-K/S,GC-K/S,GD-K/S,GN-K/S,GK-K/S,GT-K/S,SG-K/S

Ref.No.	Part No.	Part Name & Description	Pcs	Remarks	Ref.No.	Part No.	Part Name & Description	Pcs	Remarks
1	VYK1W37	FRONT CASE UNIT	1	(SILVER)	B12	XQN16+BJ5FN	SCREW	1	
1	VYK1W36	FRONT CASE UNIT	1	(BLACK)	B13	XQN16+BJ5FN	SCREW	1	
2	VXA8322	TRIPOD PLATE UNIT	1	[PAVC-CSG]	B16	XQN16+BJ5FN	SCREW	1	
4	VYF3043	BATTERY COVER UNIT	1	(SILVER)	B17	XQN16+BJ5FN	SCREW	1	
4	VYF3034	BATTERY COVER UNIT	1	(BLACK)	B18	XQN16+BJ5FN	SCREW	1	
5	VMS7608	BATTERY HINGE SHAFT	1		B19	XQN16+BJ5FN	SCREW	1	
6	VMB3971	BATTERY COVER HINGE SPRIN	1		B20	XQN16+BJ5FN	SCREW	1	
7	VMB3977	BATTERY SPRING	1		B22	VHD1680	SCREW	1	(SILVER)
8	VGU9817	BATTERY LOCK KNOB	1		B22	VHD1684	SCREW	1	(BLACK)
9	VMB3970	BATTERY LOCK SPRING	1		B25	VHD1680	SCREW	1	(SILVER)
10	VMS7612	BATTERY LOCK SHAFT	1		B25	VHD1684	SCREW	1	(BLACK)
11	VGQ8465	BATTERY CASE	1		B27	VHD1680	SCREW	1	(SILVER)
21	VYK1W43	TOP CASE UNIT	1	[PAVC-CSG](SILVER)	B27	VHD1684	SCREW	1	(BLACK)
21	VYK1W42	TOP CASE UNIT	1	[PAVC-CSG](BLACK)	B30	VHD1680	SCREW	1	(SILVER)
23	VKW3301	LED SHADE PANEL	1	[PAVC-CSG]	B30	VHD1684	SCREW	1	(BLACK)
24	VGQ8474	LED SHADE	1	[PAVC-CSG]	B32	VHD1680	SCREW	1	(SILVER)
25	VEP59016A	AF ASSIST LED P.C.B.	1	[PAVC-CSG](RTL) E.S.D.	B32	VHD1684	SCREW	1	(BLACK)
26	VKM3283	POWER LED PANEL	1	[PAVC-CSG]	B33	VHD1680	SCREW	1	(SILVER)
27	VGU9870	POWER KNOB	1	[PAVC-CSG](SILVER)	B33	VHD1684	SCREW	1	(BLACK)
27	VGU9504	POWER KNOB	1	[PAVC-CSG](BLACK)	B40	VHD1680	SCREW	1	
28	KORB01600002	TOP OPERATION UNIT	1	[PAVC-CSG]	B41	VHD1680	SCREW	1	
29	VGQ8947	STRAP HOLDER R	1	[PAVC-CSG]	B42	XQN16+BJ5FN	SCREW	1	
30	VGQ8475	MIC DUMPPER HOLDER	1	[PAVC-CSG]	B47	XQN16+BJ5FN	SCREW	1	
31	WM-64MNT506	MIC FPC UNIT	1	[PAVC-CSG]	B48	XQN16+BJ5FN	SCREW	1	
32	VMT1694	MIC DUMPPER	1	[PAVC-CSG]	B49	XQN16+B4FN	SCREW	1	
33	KOF111F00008	FLASH SW UNIT	1	[PAVC-CSG]	B51	XQN16+BJ6FN	SCREW	1	(SILVER)
35	VMS7610	FLASH SHAFT	1	[PAVC-CSG]	B51	VHD1829	SCREW	1	(BLACK)
36	VKM6802	FLASH CASE BOTTOM	1	[PAVC-CSG](SILVER)	B53	XQN16+B4FJK	SCREW	1	(SILVER)
36	VKM6760	FLASH CASE BOTTOM	1	[PAVC-CSG](BLACK)	B53	XQN16+B4FN	SCREW	1	(BLACK)
37	VMP8409	FLASH EARTH PLATE	1	[PAVC-CSG]	B54	XQN16+B4FJK	SCREW	1	(SILVER)
38	VEK0K25	FLASH UNIT	1	[PAVC-CSG]	B54	XQN16+B4FN	SCREW	1	(BLACK)
39	VMB3974	FLASH SPRING	1	[PAVC-CSG]	B60	VHD1680	SCREW	1	(SILVER)
40	VKM6766	FLASH CASE TOP	1	[PAVC-CSG](SILVER)	B60	VHD1684	SCREW	1	(BLACK)
40	VKM6759	FLASH CASE TOP	1	[PAVC-CSG](BLACK)	B61	XQN16+B4FN	SCREW	1	
41	VGQ8508	GEAR COVER	1	(SILVER)	B63	XQN16+BJ5FN	SCREW	1	
41	VGQ8487	GEAR COVER	1	(BLACK)	B64	XQN16+BJ5FN	SCREW	1	
42	VMC2017	SHOE SPRING	1		B65	XQN16+BJ5FN	SCREW	1	
43	VEP56036A	MAIN P.C.B.	1	(RTL) E.S.D.					
47	VYQ3477	JACK DOOR UNIT	1	(SILVER)					
47	VYQ3463	JACK DOOR UNIT	1	(BLACK)					
48	VEP58028A	FLASH P.C.B.	1	(RTL) E.S.D.					
49	VGQ8463	CONDENSOR HOLDER	1						
50	VJB58015	STROBO IF FPC	1						
51	VYQ3504	BATTERY CHTCHER UNIT	1						
68	VGQ8946	STRAP HOLDER L	1	[PAVC-CSG]					
69	VGQ8541	LCD HOLDER	1						
70	VGQ8557	EVF LCD CUSHION	1						
71	VYQ3861	EVF UNIT	1	[PAVC-CSG]					
72	L5EDDXM00003	EVF LCD UNIT	1						
73	VGQ8688	BARRIER CUSHION	1						
82	VXU1657	MODE DIAL UNIT	1	[PAVC-CSG](SILVER)					
82	VXU1656	MODE DIAL UNIT	1	[PAVC-CSG](BLACK)					
83	VXU1647	FLASH LOCK LEVER U	1	[PAVC-CSG]					
84	VMA0U98	HOT SHOE FIX PLATE	1	[PAVC-CSG]					
85	VML3919	FLASH LEVER	1	[PAVC-CSG]					
86	VMC1975	MODE DIAL SPRING PLATE	1	[PAVC-CSG]					
87	VGU9838	AE LOCK BUTTON	1	[PAVC-CSG](SILVER)					
87	VGU9830	AE LOCK BUTTON	1	[PAVC-CSG](BLACK)					
88	VGU9842	FLASH KNOB	1	[PAVC-CSG](SILVER)					
88	VGU9828	FLASH KNOB	1	[PAVC-CSG](BLACK)					
89	VGU9827	MODE DIAL PIECE	1	[PAVC-CSG]					
90	VGU9837	OIS ON/OFF BOTTON	1	[PAVC-CSG](SILVER)					
90	VGU9823	OIS ON/OFF BOTTON	1	[PAVC-CSG](BLACK)					
91	F2A2F2510002	E.CAPACITOR 315V 250UF	1	(C8102)					
B1	VHD1680	SCREW	1	(SILVER)					
B1	VHD1684	SCREW	1	(BLACK)					
B2	VHD1680	SCREW	1	(SILVER)					
B2	VHD1684	SCREW	1	(BLACK)					
B7	VHD1687	SCREW	1						
B8	XQN16+BJ5FN	SCREW	1	(SILVER)					
B8	XQN16+BJ5FJK	SCREW	1	(BLACK)					
B9	XQN16+BJ5FN	SCREW	1	(SILVER)					
B9	XQN16+BJ5FJK	SCREW	1	(BLACK)					

DMC-FZ50EB-K/S,EF-K/S,EGMK/S,EG-K/S,PL-K/S,PP-K/S,EE-K/S,GC-K/S,GD-K/S,GN-K/S,GK-K/S,GT-K/S,SG-K/S

Ref.No.	Part No.	Part Name & Description	Pcs	Remarks
12	VYK1221	REAR CASE UNIT	1	[PAVC-CSG](SILVER)
12	VYK1220	REAR CASE UNIT	1	[PAVC-CSG](BLACK)
13	VGQ8952	EVF COVER CUSHION	1	[PAVC-CSG]
15	VMP8646	REAR OP PLATE	1	[PAVC-CSG]
16	L0AA01A00019	SPEAKER	1	
17	VGQ8951	CROSS KEY BUTTON	1	[PAVC-CSG](SILVER)
17	VGQ8950	CROSS KEY BUTTON	1	[PAVC-CSG](BLACK)
18	VGQ8500	REAR OP BUTTON	1	[PAVC-CSG](SILVER)
18	VGQ8471	REAR OP BUTTON	1	[PAVC-CSG](BLACK)
52	VYF3102	SD DOOR UNIT	1	(SILVER)
52	VYF3103	SD DOOR UNIT	1	(BLACK)
53	VGP6199	LCD CASE BOTTOM	1	(SILVER)
53	VGP6198	LCD CASE BOTTOM	1	(BLACK)
54	VMT1701	LCD CUSION	1	
55	VMT1701	LCD CUSION	1	
56	VMA0112	LCD SHIELD	1	
57	VEP54005A	LCD IF P.C.B.	1	(RTL)
58	VGQ8954	HINGE COVER BOTTOM	1	(SILVER)
58	VGQ8953	HINGE COVER BOTTOM	1	(BLACK)
59	VGQ8956	HINGE COVER UP	1	(SILVER)
59	VGQ8955	HINGE COVER UP	1	(BLACK)
60	VYP9185	LCD CASE UP UNIT	1	(SILVER)
60	VYP9184	LCD CASE UP UNIT	1	(BLACK)
61	VYQ3824	LCD UNIT	1	
63	VGQ8949	HINGE ARM COVER	1	(SILVER)
63	VGQ8948	HINGE ARM COVER	1	(BLACK)
64	VYF3106	LCD HINGE (1) UNIT	1	
74	VGQ9002	FPC PLATE	1	
75	VMD5552	SENSOR MAGNET	1	
80	VGQ8462	GRIP PIECE REAR	1	[PAVC-CSG]
B4	XQN16+BJ4FN	SCREW	1	
B5	XQN16+BJ4FN	SCREW	1	
B6	XQN16+BJ4FN	SCREW	1	
B23	VHD1680	SCREW	1	(SILVER)
B23	VHD1684	SCREW	1	(BLACK)
B24	VHD1680	SCREW	1	(SILVER)
B24	VHD1684	SCREW	1	(BLACK)
B26	VHD1680	SCREW	1	(SILVER)
B26	VHD1684	SCREW	1	(BLACK)
B28	VHD1680	SCREW	1	(SILVER)
B28	VHD1684	SCREW	1	(BLACK)
B29	VHD1680	SCREW	1	(SILVER)
B29	VHD1684	SCREW	1	(BLACK)
B31	VHD1680	SCREW	1	(SILVER)
B31	VHD1684	SCREW	1	(BLACK)
B43	XQN16+BJ4FJK	SCREW	1	
B44	VHD1685	SCREW	1	(SILVER)
B44	VHD1819	SCREW	1	(BLACK)
B45	VHD1685	SCREW	1	(SILVER)
B45	VHD1819	SCREW	1	(BLACK)
B46	VHD1685	SCREW	1	(SILVER)
B46	VHD1819	SCREW	1	(BLACK)
B50	XQN16+BJ6FN	SCREW	1	(SILVER)
B50	VHD1829	SCREW	1	(BLACK)
B52	XQN16+BJ6FN	SCREW	1	(SILVER)
B52	VHD1829	SCREW	1	(BLACK)
B55	XQN16+BJ5FN	SCREW	1	
B57	XQN16+BJ5FN	SCREW	1	
B58	XQN16+BJ5FN	SCREW	1	
B59	XQN16+BJ5FN	SCREW	1	

Ref.No.	Part No.	Part Name & Description	Pcs	Remarks
44	N9ZZ00000308	SIDE OPERATION UNIT	1	(SILVER)
44	N9ZZ00000309	SIDE OPERATION UNIT	1	(BLACK)
101	VMG1689	ZOOM RUBBER RING	1	[PAVC-CSG]
102	VDW1215	LENS RING FRONT	1	[PAVC-CSG] (SILVER)
102	VDW1180	LENS RING FRONT	1	[PAVC-CSG] (BLACK)
103	VDP1885	ZOOM RING	1	[PAVC-CSG] (SILVER)
103	VDP1886	ZOOM RING	1	[PAVC-CSG] (BLACK)
104	VXP2625	MF RING UNIT	1	[PAVC-CSG] (SILVER)
104	VXP2626	MF RING UNIT	1	[PAVC-CSG] (BLACK)
105	VMG1690	FOCUS RUBBER RING	1	[PAVC-CSG]
108	VDW1216	LENS RING BASE	1	[PAVC-CSG] (SILVER)
108	VDW1181	LENS RING BASE	1	[PAVC-CSG] (BLACK)
109	VXQ1464	1ST LENS FRAME UNIT	1	[PAVC-CSG]
112	VDW1169	OUTSIDE FRAME	1	[PAVC-CSG]
113	VEQ4514	ZOOM ENCODER UNIT	1	[PAVC-CSG]
114	VXP2486	CAM FRAME UNIT	1	[PAVC-CSG]
119	VXP2471	2ND LENS FRAME UNIT	1	[PAVC-CSG]
125	VXQ1341	3RD LENS FRAME UNIT	1	[PAVC-CSG]
126	VXP2474	4TH LENS FRAME UNIT	1	[PAVC-CSG]
129	VMX3524	THRUST RING	1	[PAVC-CSG]
130	VMX3476	WAVE WASHER	1	[PAVC-CSG]
131	VDW1368	INSIDE FRAME	1	[PAVC-CSG]
132	VXP2476	5TH LENS FRAME UNIT	1	[PAVC-CSG]
134	VMS7620	F GUIDE POLE S	1	[PAVC-CSG]
135	VDW1369	MASTER FLANGE	1	[PAVC-CSG]
136	08S1E13F6NM	FOCUS MOTOR UNIT	1	[PAVC-CSG]
137	VDL1901	OPTICAL FILTER	1	[PAVC-CSG]
138	VMX3480	CCD CUSHION	1	[PAVC-CSG]
139	VEK0K43	CCD UNIT	1	[PAVC-CSG] E.S.D.
140	VMS7605	F GUIDE POLE L	1	[PAVC-CSG]
141	VMS7780	Z GUIDE POLE	1	[PAVC-CSG]
142	VMS7780	Z GUIDE POLE	1	[PAVC-CSG]
143	VMS7780	Z GUIDE POLE	1	[PAVC-CSG]
144	VGH4844	DECORATION RING	1	[PAVC-CSG]
147	VEK0K37	LENS FPC UNIT	1	[PAVC-CSG]
147-1	B3NAA0000074	PHOTO SENSOR	1	[PAVC-CSG]
148	VMS7602	ZOOM DRIVE PIN	1	[PAVC-CSG]
149	VMX3576	1ST LENS FRAME CUSHION	1	[PAVC-CSG]
150	VXW0815	LENS UNIT (W/O CCD)	1	[PAVC-CSG] (SILVER)
150	VXW0820	LENS UNIT (W/O CCD)	1	[PAVC-CSG] (BLACK)
B34	VHD1808	SCREW	1	
B35	VHD1808	SCREW	1	
B36	VHD1808	SCREW	1	
B37	VHD1808	SCREW	1	
B38	VHD1564	SCREW	1	
B39	VHD1564	SCREW	1	
B101	XQN14+CJ3FN	SCREW	1	[PAVC-CSG]
B102	XQN14+CJ3FN	SCREW	1	[PAVC-CSG]
B103	XQN14+CJ3FN	SCREW	1	[PAVC-CSG]
B104	XQN16+C8FN	SCREW	1	[PAVC-CSG]
B105	XQN16+C8FN	SCREW	1	[PAVC-CSG]
B106	XQN16+C8FN	SCREW	1	[PAVC-CSG]
B107	XQN16+CJ3FN	SCREW	1	[PAVC-CSG]
B111	XQN16+CJ5FN	SCREW	1	[PAVC-CSG]
B112	XQN16+CJ5FN	SCREW	1	[PAVC-CSG]
B113	XQN16+CJ5FN	SCREW	1	[PAVC-CSG]
B114	XQN16+CJ5FN	SCREW	1	[PAVC-CSG]
B115	XQN16+CJ5FN	SCREW	1	[PAVC-CSG]
B116	XQN16+CJ5FN	SCREW	1	[PAVC-CSG]
B117	XQN16+CJ5FN	SCREW	1	[PAVC-CSG]
B118	XQN16+CJ5FN	SCREW	1	[PAVC-CSG]
B119	XQN16+CJ5FN	SCREW	1	[PAVC-CSG]
B120	XQN16+CJ5FN	SCREW	1	[PAVC-CSG]
B121	XQN16+CJ5FN	SCREW	1	[PAVC-CSG]
B122	XQN16+CJ5FN	SCREW	1	[PAVC-CSG]
B123	XQN16+CJ5FN	SCREW	1	[PAVC-CSG]
B124	XQN16+CJ5FN	SCREW	1	[PAVC-CSG]
B125	XQN16+CJ5FN	SCREW	1	[PAVC-CSG]
B126	XQN16+CJ5FN	SCREW	1	[PAVC-CSG]
B127	XQN16+CJ5FN	SCREW	1	[PAVC-CSG]
B128	XQN16+CJ5FN	SCREW	1	[PAVC-CSG]
B129	XQN16+CJ5FN	SCREW	1	[PAVC-CSG]



DMC-FZ50EB-K/S,EF-K/S,EGMK/S,EG-K/S,PL-K/S,PP-K/S,EE-K/S,GC-K/S,GD-K/S,GN-K/S,GK-K/S,GT-K/S,SG-K/S

Ref.No.	Part No.	Part Name & Description	Pcs	Remarks	Ref.No.	Part No.	Part Name & Description	Pcs	Remarks
△ 202	-----	BATTERY	1		211	VQT0W42	O/I PC CONNECTOR (ENGLISH/SPANISH/ PORTUGUESE)	1	[PAVC-CSG] PL
△ 203	DE-994AB	AC ADAPTOR	1	EB,EF,EGM,EG,GN					
△ 203	DE-993BB	AC ADAPTOR	1	PL,PP	211	VQT0W41	O/I PC CONNECTOR (ENGLISH/SPANISH/ CANADIAN FRENCH)	1	[PAVC-CSG] PP
△ 203	DE-994BA	AC ADAPTOR	1	EE,GC,GD,GK,SG					
△ 203	DE-994CA	AC ADAPTOR	1	GT	211	VQT0W14	O/I PC CONNECTOR (RUSSIAN/UR)	1	[PAVC-CSG] EE
204	K1HA08CD0007	USB CABLE W/PLUG	1	[PAVC-CSG]	211	VQT0Y12	O/I PC CONNECTOR (ENGLISH/ARABIC/PERSIAN/ CHINESE(TRADITIONAL))	1	[PAVC-CSG] GC,SG
205	K1HA08CD0008	AV CABLE W/PLUG	1	[PAVC-CSG]					
206	VFC4213	SHOULDER BELT	1		211	VQT0W51	O/I PC CONNECTOR (KOREAN)	1	[PAVC-CSG] GD
207	VFF0334-S	CD-ROM	1	[PAVC-CSG] (EXCEPT PP)	211	VQT0W49	O/I PC CONNECTOR (CHINESE(SIMPLIFIED))	1	[PAVC-CSG] GK
207	VFF0333-S	CD-ROM	1	[PAVC-CSG] PP	211	VQT0W48	O/I PC CONNECTOR (CHINESE(TRADITIONAL))	1	[PAVC-CSG] GT
209	VPF1100	BAG,POLYETHYLENE	1	[PAVC-CSG] EB,EF,PP,EE,GD,GN,GK,GT	212	VQT0Z26	O/I SOFTWARE (ENGLISH)	1	[PAVC-CSG] EB,GN
209	VPF1132	BAG,POLYETHYLENE	1	[PAVC-CSG] EGM,EG,PL,GC,SG	212	VQT0Z25	O/I SOFTWARE (FRENCH)	1	[PAVC-CSG] EF
△ 210	VQT0Y05	INSTRUCTION BOOK (ENGLISH)	1	[PAVC-CSG] EB	212	VQT0Z24	O/I SOFTWARE (SPANISH/PORTUGUESE/ SWEDISH/DANISH)	1	[PAVC-CSG] EGM
△ 210	VQT0X98	INSTRUCTION BOOK (FRENCH)	1	[PAVC-CSG] EF,EG	212	VQT0Z23	O/I SOFTWARE (GERMAN/FRENCH/ ITALIAN/DUTCH)	1	[PAVC-CSG] EG
△ 210	VQT0Y01	INSTRUCTION BOOK (SPANISH)	1	[PAVC-CSG] EGM	212	VQT0Z22	O/I SOFTWARE (ENGLISH/SPANISH/ PORTUGUESE)	1	[PAVC-CSG] PL
△ 210	VQT0Y02	INSTRUCTION BOOK (PORTUGUESE)	1	[PAVC-CSG] EGM	212	VQT0Z21	O/I SOFTWARE (ENGLISH/SPANISH/ CANADIAN FRENCH)	1	[PAVC-CSG] PP
△ 210	VQT0Y03	INSTRUCTION BOOK (SWEDISH)	1	[PAVC-CSG] EGM	212	VQT0Z27	O/I SOFTWARE (RUSSIAN/UR)	1	[PAVC-CSG] EE
△ 210	VQT0Y04	INSTRUCTION BOOK (DANISH)	1	[PAVC-CSG] EGM	212	VQT0Y13	O/I SOFTWARE (ENGLISH/ARABIC/PERSIAN/ CHINESE(TRADITIONAL))	1	[PAVC-CSG] GC,SG
△ 210	VQT0X97	INSTRUCTION BOOK (GERMAN)	1	[PAVC-CSG] EG	212	VQT0Z31	O/I SOFTWARE (KOREAN)	1	[PAVC-CSG] GD
△ 210	VQT0X99	INSTRUCTION BOOK (ITALIAN)	1	[PAVC-CSG] EG	212	VQT0Z29	O/I SOFTWARE (CHINESE(SIMPLIFIED))	1	[PAVC-CSG] GK
△ 210	VQT0Y00	INSTRUCTION BOOK (DUTCH)	1	[PAVC-CSG] EG	212	VQT0Z28	O/I SOFTWARE (CHINESE(TRADITIONAL))	1	[PAVC-CSG] GT
△ 210	VQT0X94	INSTRUCTION BOOK (ENGLISH)	1	[PAVC-CSG] PL	213	VYK1P30	LENS CAP UNIT	1	
△ 210	VQT0X95	INSTRUCTION BOOK (SPANISH)	1	[PAVC-CSG] PL	214	VYQ3505	LENS HOOD UNIT	1	
△ 210	VQT0X96	INSTRUCTION BOOK (PORTUGUESE)	1	[PAVC-CSG] PL	215	VPF1193	BAG, POLYETHYLENE	1	
△ 210	VQT0X92	INSTRUCTION BOOK (ENGLISH/SPANISH)	1	[PAVC-CSG] PP	217	VPK3173	PACKING CASE	1	EB-S,EF-S,EGMS,EG-S, PL-S,EE-S,GC-S,GD-S, GN-S,GT-S,SG-S
△ 210	VQT0X93	INSTRUCTION BOOK (CANADIAN FRENCH)	1	[PAVC-CSG] PP	217	VPK3177	PACKING CASE	1	EB-K,EF-K,EGMK,EG-K, PL-K,EE-K,GC-K,GD-K, GN-K,GT-K,SG-K
△ 210	VQT0Y06	INSTRUCTION BOOK (RUSSIAN)	1	[PAVC-CSG] EE	217	VPK3172	PACKING CASE	1	PP-S
△ 210	VQT0Y07	INSTRUCTION BOOK (UR)	1	[PAVC-CSG] EE	217	VPK3176	PACKING CASE	1	PP-K
△ 210	VQT0Y08	INSTRUCTION BOOK (ENGLISH)	1	[PAVC-CSG] GC,SG	217	VPK3174	PACKING CASE	1	GK-S
△ 210	VQT0Y09	INSTRUCTION BOOK (CHINESE(TRADITIONAL))	1	[PAVC-CSG] GC,SG	217	VPK3178	PACKING CASE	1	GK-K
△ 210	VQT0Y10	INSTRUCTION BOOK (ARABIC)	1	[PAVC-CSG] GC,SG	218	VPN6443	CUSHION	1	
△ 210	VQT0Y11	INSTRUCTION BOOK (PERSIAN)	1	[PAVC-CSG] GC,SG	219	VPN6493	PAD	1	
△ 210	VQT0Y17	INSTRUCTION BOOK (KOREAN)	1	[PAVC-CSG] GD	220	RP-SD032BVE0	SD CARD (32MB)	1	EXCEPT EE/GC/SG
△ 210	VQT0Y16	INSTRUCTION BOOK (ENGLISH)	1	[PAVC-CSG] GN	221	VPF1214	SD CARD BAG, POLYETHYLENE	1	EXCEPT EE/GC/SG
△ 210	VQT0Y15	INSTRUCTION BOOK (CHINESE(SIMPLIFIED))	1	[PAVC-CSG] GK	△ 222	K2CQ2CA00006	AC CORD W/PLUG	1	EF,EGM,EG,EE,GC,SG
△ 210	VQT0Y14	INSTRUCTION BOOK (CHINESE(TRADITIONAL))	1	[PAVC-CSG] GT	△ 223	K2CT3CA00004	AC CORD W/PLUG	1	EB,GC,SG
211	VQT0W46	O/I PC CONNECTOR (ENGLISH)	1	[PAVC-CSG] EB,GN	△ 224	K2CA2CA00027	AC CORD W/PLUG	1	GT
211	VQT0W45	O/I PC CONNECTOR (FRENCH)	1	[PAVC-CSG] EF	△ 224	K2CA2CA00020	AC CORD W/PLUG	1	GK
211	VQT0W44	O/I PC CONNECTOR (SPANISH/PORTUGUESE/ SWEDISH/DANISH)	1	[PAVC-CSG] EGM	△ 226	K2CJ2DA00008	AC CORD W/PLUG	1	GN
211	VQT0W43	O/I PC CONNECTOR (GERMAN/FRENCH/ ITALIAN/DUTCH)	1	[PAVC-CSG] EG	△ 227	RJA0078-1X	AC CORD W/PLUG	1	GD

# S7. Exploded View

## S7.1. Frame and Casing Section (1)

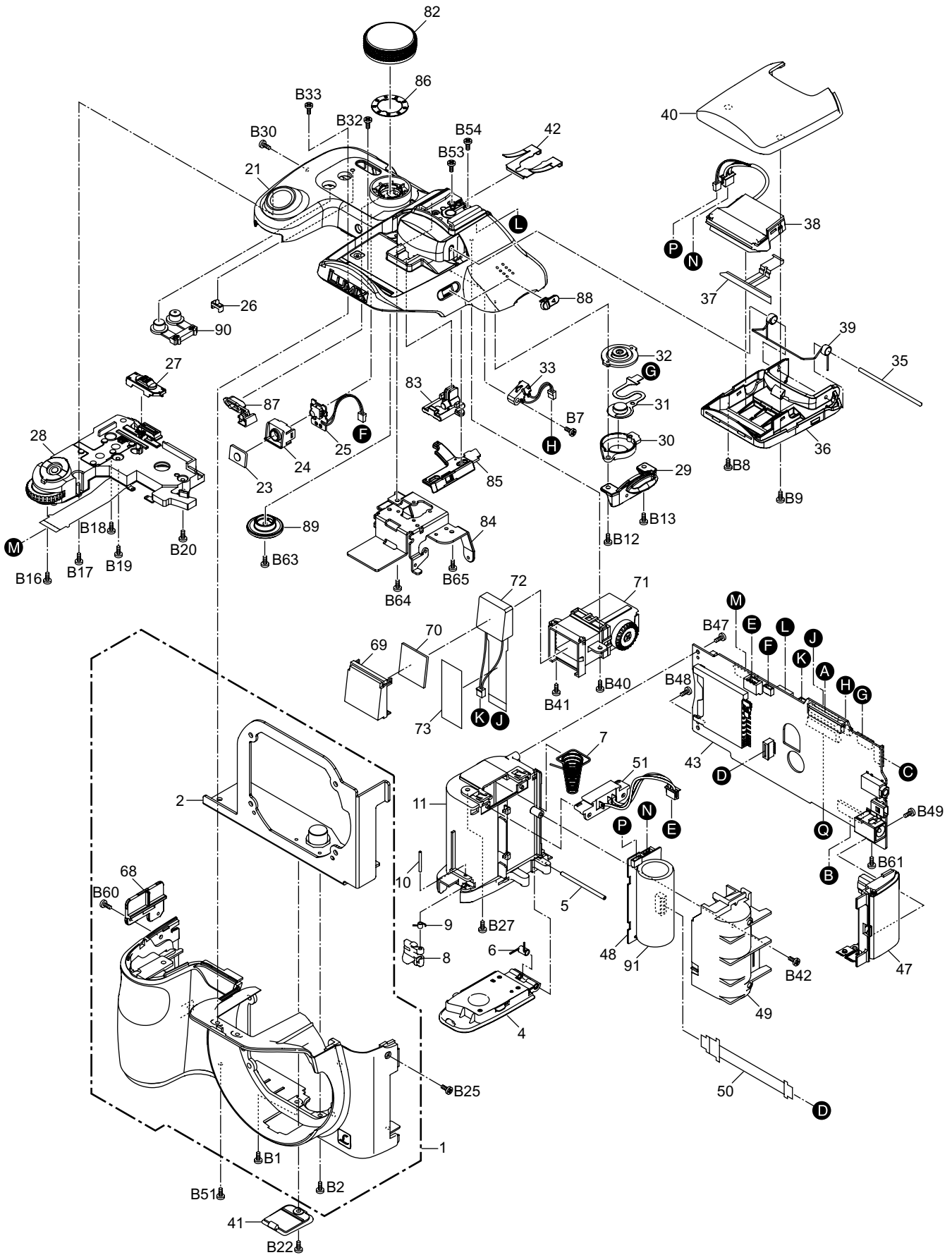

## S7.2. Frame and Casing Section (2)

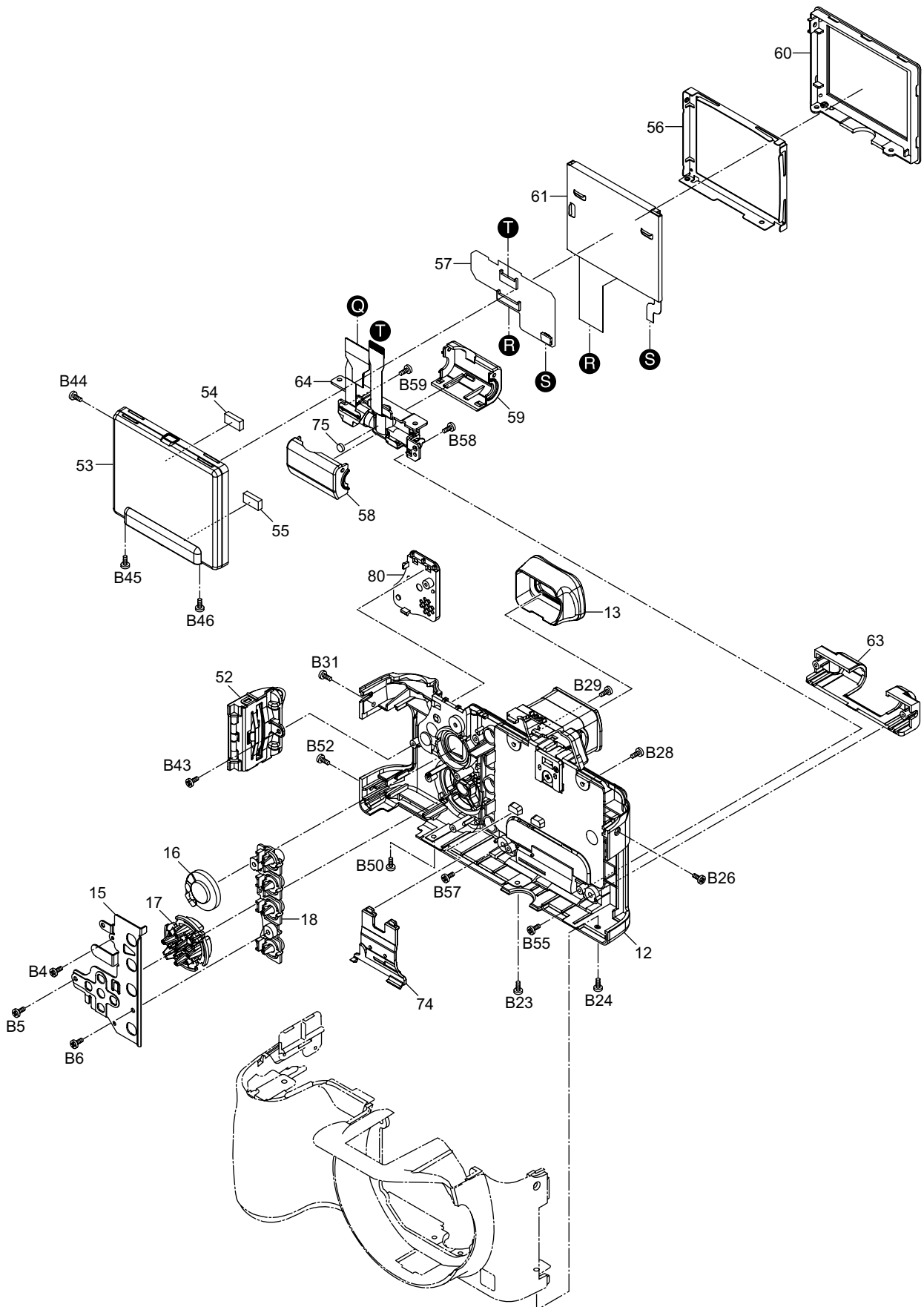

### S7.3. Frame and Casing Section (3)

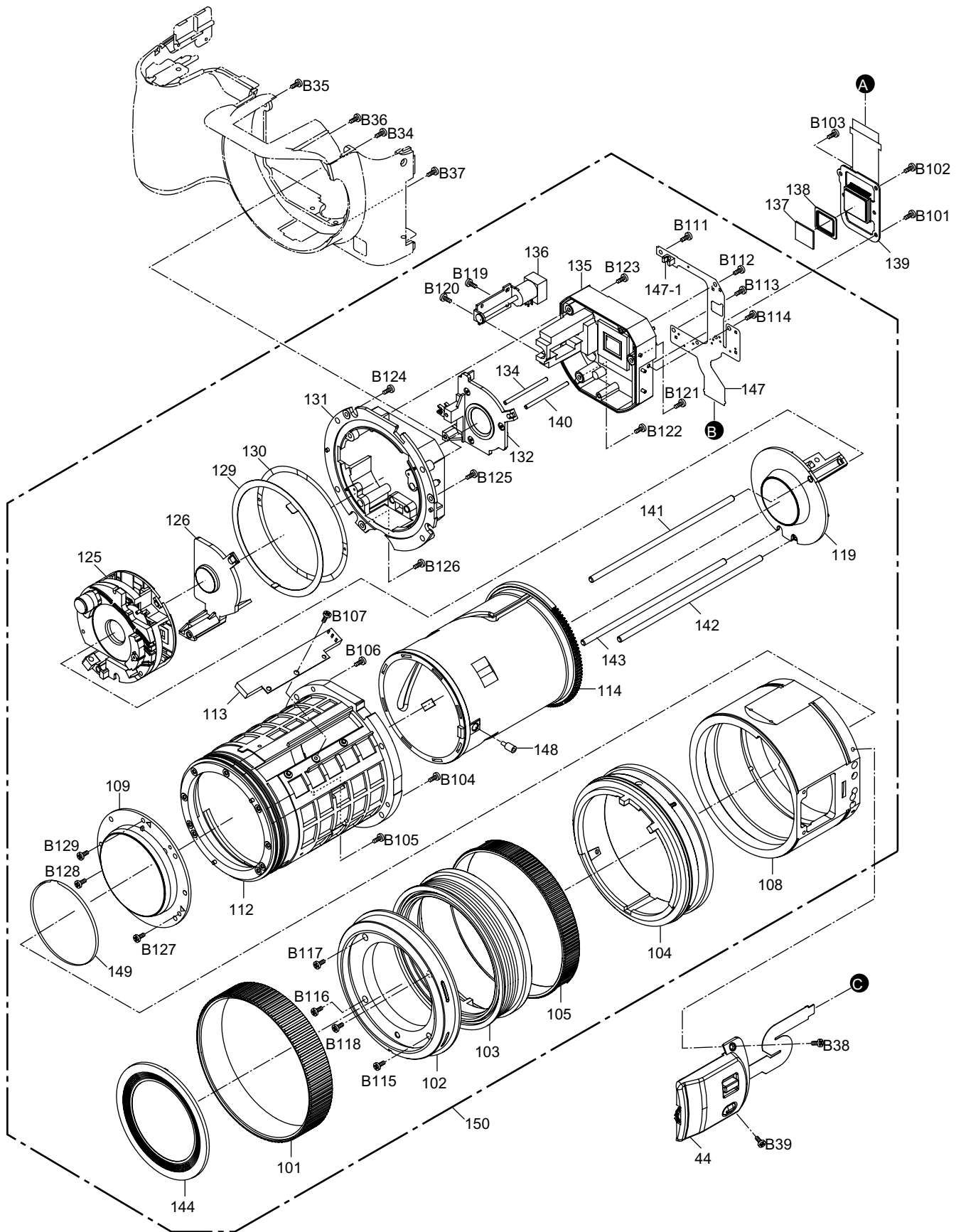

## S7.4. Packing Parts and Accessories Section

