

Service Manual

Notebook Computer

Model No. **CF-74JCJBDxM**

TOUGHBOOK

This is the Service Manual for
the following areas.
M ...for U.S.A. and Canada

Model No. CF-74JCJBD1M

1: Operation System

A: Microsoft® Windows® XP Professional SP 2

J: Microsoft® Windows® VISTA Business SP 1

 **WARNING**

This service information is designed for experienced repair technicians only and is not designed for use by the general public. It does not contain warnings or cautions to advise non-technical individuals of potential dangers in attempting to service a product. Products powered by electricity should be serviced or repaired only by experienced professional technicians. Any attempt to service or repair the product or products dealt with in this service information by anyone else could result in serious injury or death.

Panasonic®

c 2008 Matsushita Electric Industrial Co., Ltd. All rights reserved.
Unauthorized copying and distribution is a violation of law.

WARNING

For U.K.

This apparatus must be earthed for your safety.

To ensure safe operation the three-pin plug must be inserted only into a standard three-pin power point which is effectively earthed through the normal household wiring.

Extension cords used with the equipment must be three-core and be correctly wired to provide connection to earth. Wrongly wired extension cords are a major cause of fatalities.

The fact that the equipment operates satisfactorily does not imply that the power point is earthed and that the installation is completely safe.

For your safety, if you have any doubt about the effective earthing of the power point, consult a qualified electrician.

FOR YOUR SAFETY PLEASE READ THE FOLLOWING TEXT CAREFULLY

This appliance is supplied with a moulded three pin mains plug for your safety and convenience.

A 3 amp fuse is fitted in this plug.

Should the fuse need to be replaced please ensure that the replacement fuse has a rating of 3 amps and that it is approved by ASTA or BSI to BS 1362.

Check for the ASTA mark  or the BSI mark  on the body of the fuse.

If the plug contains a removable fuse cover you must ensure that it is refitted when the fuse is replaced.

If you lose the fuse cover the plug must not be used until a replacement cover is obtained.

A replacement fuse cover can be purchased from your local Panasonic Dealer.

IF THE FITTED MOULDED PLUG IS UNSUITABLE FOR THE SOCKET OUTLET IN YOUR HOME THEN THE FUSE SHOULD BE REMOVED AND THE PLUG CUT OFF AND DISPOSED OF SAFELY.

THERE IS A DANGER OF SEVERE ELECTRICAL SHOCK IF THE CUT OFF PLUG IS INSERTED INTO ANY 13 AMP SOCKET.

If a new plug is to be fitted please observe the wiring code as shown below.

If in any doubt please consult a qualified electrician.

Warning: THIS APPLIANCE MUST BE EARTHED.

Important

The wires in this mains lead are coloured in accordance with the following code:

Green-and-yellow:	Earth
Blue:	Neutral
Brown:	Live

As the colours of the wires in the mains lead of this apparatus may not correspond with the coloured markings identifying the terminals in your plug, proceed as follows:

The wire which is coloured GREEN-and-YELLOW must be connected to the terminal in the plug which is marked by the letter E or by the safety earth symbol  coloured GREEN or GREEN-and-YELLOW.

The wire which is coloured Blue must be connected to the terminal which is marked with the letter N or coloured BLACK.

The wire which is coloured Brown must be connected to the terminal which is marked with the letter L or coloured RED.

The mains plug on this equipment must be used to disconnect the mains power.

Please ensure that a socket outlet is available near the equipment and shall be easily accessible.

How to replace the fuse

Open the fuse compartment with a screwdriver and replace the fuse.

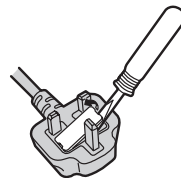

Warnings

- This equipment is not designed for connection to an IT power system.
(An IT system is a system having no direct connections between live parts and Earth; the exposed-conductive-parts of the electrical installation are earthed.
An IT system is not permitted where the computer is directly connected to public supply systems in the U.K.)
- Disconnect the mains plug from the supply socket when the computer is not in use.

This equipment is produced to BS800/1983.

LASER SAFETY INFORMATION

For U.S.A.

Class 1 LASER-Product

This product is certified to comply with DHHS Rules 21 CFR Subchapter J.

This product complies with European Standard EN60825 (or IEC Publication 825)

For all areas

This equipment is classified as a class 1 level LASER product and there is no hazardous LASER radiation.

Caution:

- (1) Use of controls or adjustments or performance of procedures other than those specified herein may result in hazardous radiation exposure.
- (2) The drive is designed to be incorporated into a computer-based system or unit which has an enclosing cover. It should never be used as a stand alone drive.

Danger:

The serviceman should not remove the cover of drive unit and should not service because the drive unit is a nonserviceable part.
Please check DANGER label on PD-drive unit.

- Unplug the AC power cord to the equipment before opening the top cover of the drive.
When the power switch it on, do not place your eyes close to the front panel door to look into the interior of the unit.

LASER Specification

Class 1 level LASER Product

Wave Length: DVD 658±8 nm

CD 775~815 nm

Laser safety information is appropriate only when drive with laser is installed.

SAFETY PRECAUTIONS

1. Before servicing, unplug the power cord to prevent an electric shock.
2. When replacing parts, use only manufacturer's recommended components for safety.
3. Check the condition of the power cord. Replace if wear or damage is evident.
4. After servicing, be sure to restore the lead dress, insulation barriers, insulation papers, shields, etc.

Important Safety Instructions

When using your telephone equipment, basic safety precautions should always be followed to reduce the risk of fire, electric shock and injury to persons, including the following:

1. Do not use this product near water, for example, near a bath tub, wash bowl, kitchen sink or laundry tub, in a wet basement or near a swimming pool.
2. Avoid using a telephone (other than a cordless type) during an electrical storm. There may be a remote risk of electric shock from lightning.
3. Do not use the telephone to report a gas leak in the vicinity of the leak.
4. Use only the power cord and batteries indicated in this manual. Do not dispose of batteries in a fire. They may explode. Check with local codes for possible special disposal instructions.

SAVE THESE INSTRUCTIONS

LITHIUM BATTERY

This computer contains a lithium battery to enable the date, time, and other data to be stored. The battery should only be exchanged by authorized service personnel.

Warning! A risk of explosion from incorrect installation or misapplication may possibly occur.

LITHIUM BATTERY ⚠

• CAUTION

Danger of explosion if battery is incorrectly replaced.

Replace only with the same or equivalent type recommended by the equipment manufacturer.

Dispose of used batteries according to the manufacturer's instructions.

LITHIUMBATTERIES ⚠

Vorsicht!

Explosionsgefahr bei unsachgemäßem Austausch der Batterie. Ersatz nur durch denselben oder einen vom Hersteller empfohlenen ähnlichen Typ. Entsorgung gebrauchter Batterien nach Angaben des Herstellers.

PILE AU LITHIUM ⚠

ATTENTION: IL Y A DANGER D'EXPLOSION S' IL Y A REMPLACEMENT INCORRECT DE LA PILE. REMPLACER UNIQUEMENT AVEC UNE PILE DU MÊME TYPE OU D'UN TYPE RECOMMANDÉ PAR LE CONSTRUCTEUR. METTRE AU RÉBUT LES PILES USAGÉES CONFORMÉMENT AUX INSTRUCTIONS DU FABRICANT.

Precautions (Battery Pack)

Do Not Use with Any Other Product

The battery pack is rechargeable and was intended for the specified product. If it is used with a product other than the one for which it was designed, electrolyte leakage, generation of heat, ignition or rupture may result.

Do Not Charge the Battery Using Methods Other Than Those Specified

If the battery is not charged using one of the specified methods, electrolyte leakage, generation of heat, ignition or rupture may result.

Do Not Throw the Battery Pack into a Fire or Expose It to Excessive Heat

Generation of heat, ignition or rupture may result.

Avoid Extreme Heat (Near the Fire, in Direct Sunlight, for Example)

Electrolyte leakage, generation of heat, ignition or rupture may result.

Do Not Insert Sharp Objects into the Battery Pack, Expose It to Bumps or Shocks, Disassemble, or Modify It

Electrolyte leakage, generation of heat, ignition or rupture may result.

Do Not Short the Positive (+) and Negative (-) Contacts

Generation of heat, ignition or rupture may result. Do not place the battery pack together with articles such as necklaces or hairpins when carrying or storing.

Do Not Use This Product with a Battery Pack Other Than the One Specified

Use only the specified battery pack with your product. Use of battery packs other than those manufactured and supplied by Panasonic may present a safety hazard (generation of heat, ignition or rupture).



A lithium ion battery that is recyclable powers the product you have purchased.

Please call 1-800-8-BATTERY for information on how to recycle this battery.

L'appareil que vous vous êtes procuré est alimenté par une batterie au lithium-ion.

Pour des renseignements sur le recyclage de la batterie, veuillez composer le 1-800-8-BATTERY.

- Do not touch the terminals on the battery pack. The battery pack may no longer function properly if the contacts are dirty or damaged.
- Do not expose the battery pack to water, or allow it to become wet.
- If the battery pack will not be used for a long period of time (a month or more), charge or discharge (use) the battery pack until the remaining battery level becomes 30% to 40% and store it in a cool, dry place.
- This computer prevents overcharging of the battery by recharging only when the remaining power is less than approx. 95% (when Economy Mode (ECO) is enabled: 75%) of capacity.
- The battery pack is not charged when the computer is first purchased. Be sure to charge it before using it for the first time. When the AC adaptor is connected to the computer, charging begins automatically.
- Should the battery leak and the fluid get into your eyes, do not rub your eyes. Immediately flush your eyes with clear water and see a doctor for medical treatment as soon as possible.

NOTE

- The battery pack may become warm during recharging or normal use. This is completely normal.
- Recharging will not commence if internal temperature of the battery pack is outside of the allowable temperature range (0 °C to 55 °C {32 °F to 131 °F}). (→  *Reference Manual* "Battery Power") Once the allowable range requirement is satisfied, charging begins automatically. Note that the recharging time varies based on the usage conditions. (Recharging takes longer than usual when the temperature is 10 °C {50 °F} or below.)
- If the temperature is low, the operating time is shortened. Only use the computer within the allowable temperature range.
- The battery pack is a consumable item. If the amount of time the computer can be run by using a particular battery pack becomes dramatically shorter and repeated recharging does not restore its performance, the battery pack should be replaced with a new one.
- When transporting a spare battery inside a package, briefcase, etc., it is recommended that it be placed in a plastic bag so that its contacts are protected.
- Always power off the computer when it is not in use. Leaving the computer on when the AC adaptor is not connected will exhaust the remaining battery capacity.

CONTENTS

1. Specifications	1-1
2. Names and Functions of Parts	2-1
3. Block Diagram	3-1
4. Diagnosis Procedure	4-1
5. Power-On Self Test (Boot Check)	5-1
6. List of Error Codes <Only when the port replicator is connected>	6-1
7. Self Diagnosis Test	7-1
8. Wiring Connection Diagram	8-1
9. Disassembly/Reassembly	9-1
10. Exploded View	10-1
11. Replacement Parts List	11-1

1. Specifications

This page provides the specifications for the basic model. The model number is different according to the unit configuration.

To check the model number:

Check the bottom of the computer or the box the computer came in at the time of purchase.

To check CPU speed, memory size and the hard disk drive (HDD) size:

Run the Setup Utility ( *Reference Manual* "Setup Utility") and select [Information] menu.

[Processor Speed]: CPU speed, [Memory Size]: Memory size, [Hard Disk]: Hard disk drive size

Main Specifications

Model No.		CF-74JCJBDAM / CF-74JCJBDJM / CF-74KCJBZAM / CF-74JCJDDAM / CF-74JCJFDAM
CPU/Secondary cache memory		Intel® Core™2 Duo Processor P8600 (2.4 GHz, 3 MB ^{*1} L2 cache, 1066 MHz FSB)
Chip Set		Mobile Intel® GM45 Express Chip set
Main Memory ^{*2}		1 GB ^{*1} , DDR2 SDRAM (4 GB ^{*1} Max.)
Video Memory		Windows Vista UMA (285 MB ^{*1} , Max. / 1423 MB ^{*1} Max. with expanded memory) ^{*3} Windows XP UMA (512 MB ^{*1} Max. / 1024 MB ^{*1} Max. with expanded memory) ^{*3}
Hard Disk Drive		160 GB ^{*4} (Serial ATA) Windows Vista : Approx. 2 GB ^{*4} is used as a partition with recovery tools. (Users cannot use this partition.)
CD/DVD drive		DVD MULTI Drive built-in, Buffer underrun error prevention function: Supported
Continuous Data Transfer Speed ^{*5*6}	Reading ^{*7}	DVD-RAM ^{*8} : 5X (Max.) DVD-R ^{*9} : 8X (Max.) DVD-R DL: 6X (Max.) DVD-RW: 6X (Max.) DVD-ROM: 8X (Max.) CD-ROM: 24X (Max.) CD-R: 24X (Max.) CD-RW: 24X (Max.) +R: 8X (Max.) +R DL: 6X (Max.) +RW: 6X (Max.) High-Speed CD-RW: 24X (Max.) Ultra-Speed CD-RW: 24X (Max.)
	Writing ^{*10}	DVD-RAM ^{*8} : 2X/3X/3-5X (4.7 GB ^{*4}) DVD-R: 1X/2X/2-4X/2-6X/2-8X DVD-RW: 1X/2X/2-4X +R: 2.4X/2.4-4X/2.4-6X/2.4-8X +R DL: 2.4X +RW: 2.4X/2.4-4X CD-R: 4X/8X/8-12X/8-16X/ 8-24X CD-RW: 4X High-Speed CD-RW: 4X/8X/10X Ultra-Speed CD-RW: 8X/10X
Supported Discs/Format	Reading	DVD-ROM (4.7 GB, 8.5 GB, 9.4 GB, 17 GB) DVD-Video DVD-R ^{*9} (1.4 GB, 3.95 GB, 4.7 GB) ^{*4} DVD-R DL (8.5 GB) ^{*4} DVD-RW (Ver.1.1/1.2 1.4 GB, 2.8 GB, 4.7 GB, 9.4 GB) ^{*4} DVD-RAM ^{*8} (1.4 GB, 2.8 GB, 2.6 GB, 4.7 GB, 5.2 GB, 9.4 GB) ^{*4} +R (4.7 GB) ^{*4} +R DL (8.5 GB) ^{*4} +RW (4.7 GB) ^{*4} CD-Audio CD-ROM (XA compatible) CD-R Photo CD (multiple session compatible) Video CD CD-EXTRA CD-RW High-Speed CD-RW Ultra-Speed CD-RW CD-TEXT
	Writing	DVD-RAM ^{*8} (1.4 GB, 2.8 GB, 4.7 GB, 9.4 GB) ^{*4} DVD-R (1.4 GB, 4.7 GB for General) ^{*4} DVD-RW (Ver.1.1/1.2 1.4 GB, 2.8 GB, 4.7 GB, 9.4 GB) ^{*4} +R (4.7 GB) ^{*4} +R DL (8.5 GB) ^{*4} +RW (4.7 GB) ^{*4} CD-R CD-RW High-Speed CD-RW Ultra-Speed CD-RW
Display Method		13.3 XGA type (TFT) (1024 × 768 dots) with Touchscreen
Internal LCD		65,536/16,777,216 colors (800 × 600 dots / 1024 × 768 dots) ^{*11}
External Display ^{*12}		65,536/16,777,216 colors (800 × 600 dots / 1024 × 768 dots / 1280 × 1024 dots / 1400 × 1050 dots / 1600 × 1200 dots / 2048 × 1536 dots)
Wireless LAN ^{*13}		Intel® WiFi Link 5100
Bluetooth ^{*14}		Refer to page 31 of Instruction Manual.
LAN		IEEE 802.3 10Base-T / IEEE 802.3u 100BASE-TX / IEEE 802.3ab 1000BASE-T
Modem		Data: 56 kbps (V.92) FAX: 14.4 kbps
Sound		WAVE and MIDI playback, Intel® High Definition Audio subsystem support
Security Chip		TPM (TCG V1.2 compliant) ^{*15}
Card Slots	PC Card Slot	x 1, Type I or Type II, Allowable current 3.3 V: 400 mA, 5 V: 400 mA
	ExpressCard Slot	x 1, ExpressCard/34 or ExpressCard/54
	SD Memory Card Slot ^{*16}	x 1
	Smart Card Slot ^{*17}	x 1

Main Specifications

Model No.	CF-74JCJBDAM / CF-74JCJBDJM / CF-74KCJBZAM / CF-74JCJDDAM / CF-74JCJFDAM		
RAM Module Slot	x 1, DDR2 SDRAM, 200-pin, 1.8 V, SO-DIMM, PC2-6400 Compliant		
Interface	USB Ports x 2 (4-pin, USB2.0) ^{*18} / Serial Port (Dsub 9-pin male) / Modem Port (RJ-11) / LAN Port (RJ-45) / External Display Port (Mini Dsub 15-pin female) / Microphone Jack (Miniature jack, 3.5 DIA) / Headphone Jack (Miniature jack, 3.5 DIA, Impedance 32 Ω, Output Power 4mW x 2, Stereo) / Expansion Bus Connector (Dedicated 65-pin female)		
Keyboard / Pointing Device	87 keys / Touch Pad		
Fingerprint Reader ^{*19}	Array Size : 248 x 4 pixels, Image Size : 248 x 360 pixels, Image Resolution : 508 DPI		
Power Supply	AC adaptor or Battery pack		
AC Adaptor ^{*20}	Input: 100 V - 240 V AC, 50 Hz/60 Hz, Output: 15.6 V DC, 8.0 A		
Battery Pack	Li-ion 11.1 V, 7.8 Ah		
Operating Time ^{*21}	Approx. 8 hours		
Charging Time ^{*22}	Approx. 4.5 hours		
Power Consumption ^{*23}	Approx. 30 W ^{*24} / Approx. 120 W (maximum when recharging in the ON state)		
Physical Dimensions (W x D x H) (including the carrying handle)	303.5 mm x 293.3 mm x 43.6 mm - 60.1 mm {12.0 " x 11.6 " x 1.7 - 2.4 "}		
Weight (including the carrying handle)	Approx. 2.7 kg {Approx. 6.0 lb.}		
Envi- ronment	Oper- ating	Temperature	5 °C to 35 °C {5 °F to 95 °F}
		Humidity	30% to 80% RH (No condensation)
	Stor- age	Temperature	-20 °C to 60 °C {-4 °F to 140 °F}
		Humidity	30% to 80% RH (No condensation)

Software

Model No.	CF-74JCJBDJM	CF-74JCJBDAM / CF-74KCJBZAM / CF-74JCJDDAM / CF-74JCJFDAM
OS ^{*25}	Windows Vista [®] Business Service Pack 1	Microsoft [®] Windows [®] XP Professional Service Pack 2 with Advanced Security Technologies (NTFS File System)
Pre-installed Software	Adobe Reader, PC Information Viewer, Loupe Utility, B's Recorder GOLD9 BASIC, B's CLiP 7 ^{*26} , Intel [®] PROSet / Wireless Software ^{*13} , Bluetooth [™] Stack for Windows [®] by TOSHIBA ^{*14} , Wireless Switch Utility, Wireless Connection Disable Utility ^{*26} , Hotkey Settings, Battery Recalibration Utility, Infineon TPM Professional Package ^{*26} , Protector Suite QL ^{*19 *26} , Setup Utility, Hard Disk Data Erase Utility ^{*27} , PC-Diagnostic Utility	
	WinDVD [™] 8 (OEM Version)	MediaPlayer10, Icon Enlarger, WinDVD [™] 5 (OEM Version)

Wireless LAN

Data Transfer Rates	IEEE802.11a : 54/48/36/24/18/12/9/6 Mbps (automatically switched) ^{*28} IEEE802.11b : 11/5.5/2/1 Mbps (automatically switched) ^{*28} IEEE802.11g : 54/48/36/24/18/12/9/6 Mbps (automatically switched) ^{*28} IEEE802.11n : (HT20) 144.4/130/117/115.6/104/86.7/78/65/58.5/57.8/52/43.3/39/28.9/26/19.5/ 14.4/13/6.5 Mbps (automatically switched) ^{*28} (HT40) 300/270/243/240/216/180/162/130/120/117/108/104/90/81/78/60/54/52/ 39/30/27/26/13 Mbps (automatically switched) ^{*28}
Standards Supported	IEEE802.11a / IEEE802.11b / IEEE802.11g / IEEE802.11n(Draft 2.0)
Transmission Method	OFDM system, DS-SS system
Wireless Channels Used	IEEE802.11a : Channels 36/40/44/48/52/56/60/64/100/104/108/112/116/132/136/140/149/153/ 157/161/165 IEEE802.11b/IEEE802.11g : Channels 1 to 11 IEEE802.11n : Channels 1-11/36/40/44/48/52/56/60/64/100/104/108/112/116/132/136/140/149/ 153/157/161/165
RF Frequency Band	IEEE802.11a : 5.18 GHz - 5.32 GHz, 5.5 GHz - 5.58 GHz, 5.66 GHz - 5.7 GHz, 5.745 GHz - 5.825 GHz IEEE802.11b/IEEE802.11g : 2.412 GHz - 2.462 GHz IEEE802.11n : 2.412 GHz - 2.462 GHz, 5.15 GHz - 5.35 GHz, 5.5 GHz - 5.58 GHz, 5.66 GHz - 5.7 GHz, 5.745 GHz - 5.85 GHz

Bluetooth™

Bluetooth Version	2.0 + EDR
Transmission Method	FHSS system
Wireless Channels Used	Channels 1 to 79
RF Frequency Band	2.402 GHz - 2.48 GHz

*1 1 MB = 1,048,576 bytes / 1 GB = 1,073,741,824 bytes

*2 You can physically expand the memory up to 4 GB, but the total amount of usable memory available will be less depending on the actual system configuration.

*3 A segment of the main memory is allotted automatically depending on the computer's operating status. The size of the Video Memory cannot be set by the user. The size of Video memory is allotted depending on the operating system.

*4 1 GB = 1,000,000,000 bytes. Your operating system or some application software will report as fewer GB.

*5 Data transfer speeds indicate values measured by Matsushita Electric Industrial Co., Ltd. The data transfer rate of DVD per 1X speed is 1,350 KB/s. The data transfer rate of CD per 1X speed is 150 KB/s.

*6 Performance of CD-R, CD-RW, DVD-RAM, DVD-R, DVD-R DL, DVD-RW, +R, +R DL, and +RW cannot be guaranteed depending on writing status and recording format. Also, some data cannot be played back depending on the disc, settings, and environment being used. Does not support writing to DVD-R DL.

*7 If an unbalanced disc (e.g., a disc with which the balance has been displaced from the center) is inserted, the speed may become slower if there are large vibrations while the disc is rotating.

*8 Only non-cartridge type or removable cartridge type can be used.

*9 DVD-R is compatible with 4.7 GB (for General) playback. DVD-R (for Authoring) playback is compatible with discs recorded using Disc-at-Once recording.

*10 Depending on the disc, the writing speed may become slower.

*11 A 16,777,216 color display is achieved by using the dithering function.

*12 Display may be impossible using some connected external displays.

*13 Only for model with wireless LAN.

*14 Only for model with Bluetooth.

*15 For information on TPM, refer to the Installation Manual of "TrustedPlatform Module (TPM)" by the following procedure.

Windows Vista

Click  (Start) and input "c:\util\drivers\tpm\README.pdf" in [Start Search], and press **Enter**.

Windows XP

Click [start] - [Run] and input "c:\util\drivers\tpm\README.pdf" and press **Enter**.

*16 This slot is compatible with High-Speed Mode. Operation has been tested and confirmed using Panasonic SD/SDHC Memory Cards with a capacity of up to 32 GB. Operation on other SD equipment is not guaranteed.

*17 Only for model with Smart Card slot.

*18 Does not guarantee operation of all USB-compatible peripherals.

*19 Only for model with Fingerprint reader.

*20 <Only for North America>

The AC adaptor is compatible with power sources up to 240 V AC adaptor. This computer is supplied with a 125 V AC compatible AC cord. 20-M-1-1

*21 Measured at LCD brightness : 60 cd/m²

Varies depending on the usage conditions, or when an optional device is attached.

*22 Varies depending on the usage conditions, CPU speed, etc.

*23 Approx. 0.9 W when the battery pack is fully charged (or not being charged) and the computer is off.

*24 Rated power consumption. 23-E-1

*25 Operations of this computer are not guaranteed except for the pre-installed OS and the OS which is installed by using the Product Recovery DVD-ROM provided by Panasonic.

*26 Must be installed before use.

*27 The Product Recovery DVD-ROM is required.

*28 These are speeds specified in IEEE802.11a+b+g+n standards. Actual speeds may differ.

2. Names and Functions of Parts

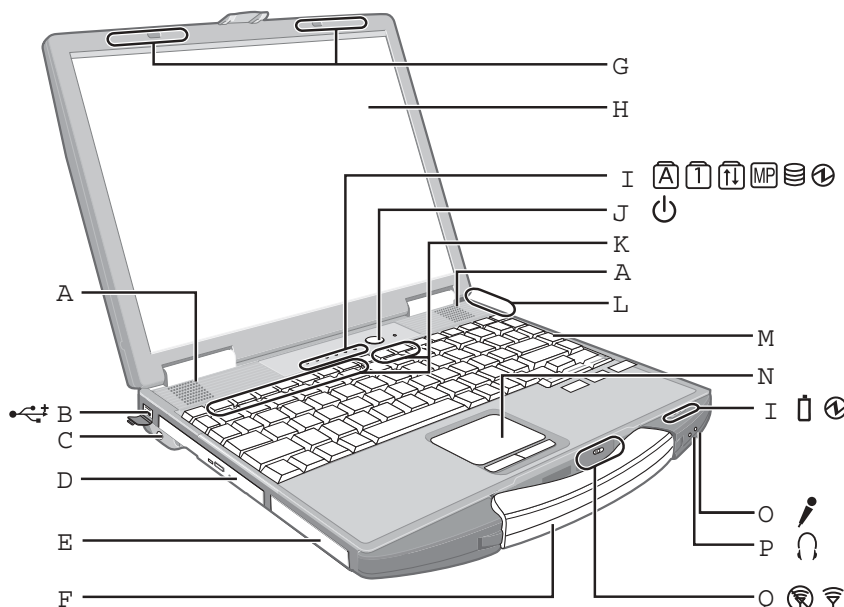

A : Speaker

Reference Manual "Key Combinations"

B : USB port

Reference Manual "USB Devices"

C : Stylus holder

D : Multimedia pocket

Reference Manual "Multimedia Pocket"

E : Hard disk drive

Reference Manual "Hard Disk Drive"

F : Carrying handle

G : Wireless LAN antenna

<Only for model with wireless LAN>

Reference Manual "Wireless LAN"

H : LCD

<Only for model with touchscreen>

Reference Manual "Touchscreen"

I : LED indicator

: Caps lock

: Numeric key (NumLk)

: Scroll lock (ScrLk)

: Multimedia pocket device status

Reference Manual "Multimedia Pocket"

: Hard disk drive status

: Power status

(Off: Power off/Hibernation, Green: Power on, Blinking green: **Windows Vista** Sleep/

Windows XP Standby, Blinking green rapidly: Cannot power on or resume due to low temperature.)

: Battery status

Reference Manual "Battery Power"

J : Power switch

K : Function key

Reference Manual "Key Combinations"

L : Bluetooth antenna

<Only for model with Bluetooth>

Reference Manual "Bluetooth"

M : Keyboard

N : Touch pad

O : Microphone jack

A condenser microphone can be used. If other types of microphones are used, audio input may not be possible, or malfunctions may occur as a result.

- When recording in stereo using a stereo microphone:

Windows Vista

Click (Start) - [Control Panel] - [Hardware and Sound] - [Sound] - [Recording] - [Microphone] - [Properties], and then add a check mark for [No Filtering] in [Microphone Enhancements].

Windows XP

Click [start] - [All Programs] - [SoundMAX] - [Control Panel] and select [Microphone], and then add a check mark for [No Filtering] in [Microphone Enhancements].

- When using a monaural microphone with a 2-terminal plug:

Windows Vista

Click (Start) - [Control Panel] - [Hardware and Sound] - [Sound] - [Recording] - [Microphone] - [Properties], and then add a check mark for [Voice Recording] in [Microphone Enhancements].

Otherwise, only audio on the left track will be recorded.

Windows XP

Click [start] - [All Programs] - [SoundMAX] - [Control Panel] and select [Microphone], and then add a check mark for [Voice Recording] in [Microphone Enhancements].

Otherwise, only audio on the left track will be recorded.

P : Headphone jack

You can connect headphones or amplified speakers. When they are connected, audio from the internal speakers is not heard.

Q : Wireless switch

Reference Manual "Disabling/Enabling Wireless Communication" "Wireless LAN" "Bluetooth"

Right side

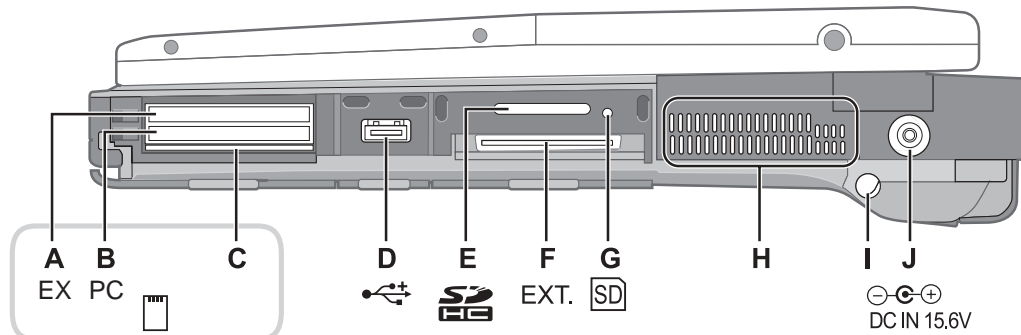

Rear side

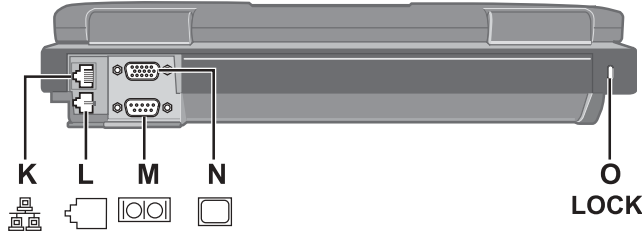

Bottom

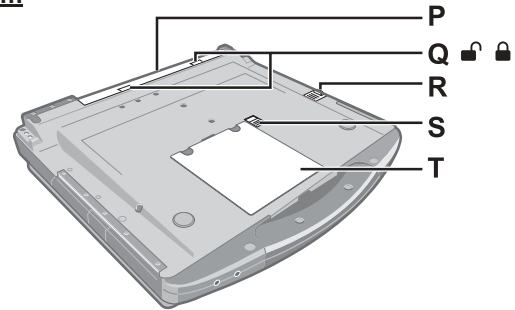

A : ExpressCard slot

Reference Manual "PC Card / ExpressCard"

B : PC Card slot

Reference Manual "PC Card / ExpressCard"

C : Smart Card slot

<Only for model with Smart Card slot>

Reference Manual "Smart Card"

D : USB port

Reference Manual "USB Devices"

E : SD Memory Card slot

Reference Manual "SD Memory Card"

F : Expansion bus connector

Reference Manual "Mini Port Replicator"

G : SD Memory Card indicator

(Blinking: During access or a password is requested)

Reference Manual "SD Memory Card"

H : Ventilation hole

I : Stylus holder

J : DC-IN jack

K : LAN port

Reference Manual "LAN"

L : Modem port

Reference Manual "Modem"

M : Serial port

N : External display port

Reference Manual "External Display"

O : Security lock

A Kensington cable can be connected.
For further information, read the manual that comes with the cable.

P : Battery pack

Specified Battery pack: CF-VZSU43A
The battery pack is a consumable item. If you continue to use a battery pack after it has degraded, problems may occur. Be sure to replace the degraded battery pack with a new battery pack of the specified type.

Q : Battery latch

R : Multimedia pocket release button

Reference Manual "Multimedia Pocket"

S : Hard disk drive latch

Reference Manual "Hard Disk Drive"

T : RAM module slot

Reference Manual "RAM Module"

NOTE

This computer contains a magnet and magnetic products at the locations circled in the illustration at right. Avoid leaving metallic object or magnetic media in contact with these areas.



3 Block Diagram

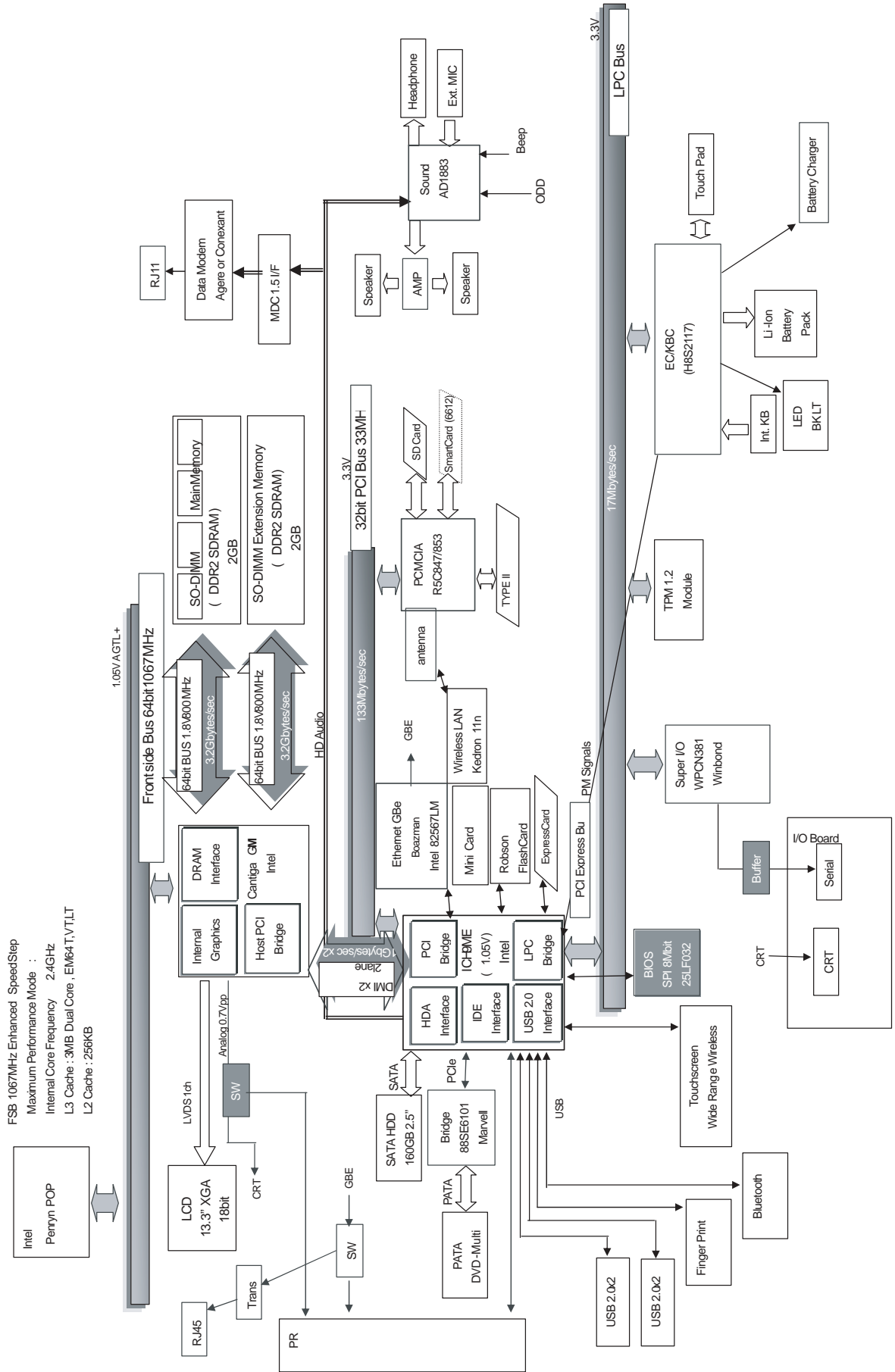

4 Diagnosis Procedure

4.1. Basic Procedures

The basic procedures for diagnosis, disassembly, and test of defective parts of a set to be repaired are summarized below. For details, refer to relevant pages in the Service Manual.

● Flow Chart

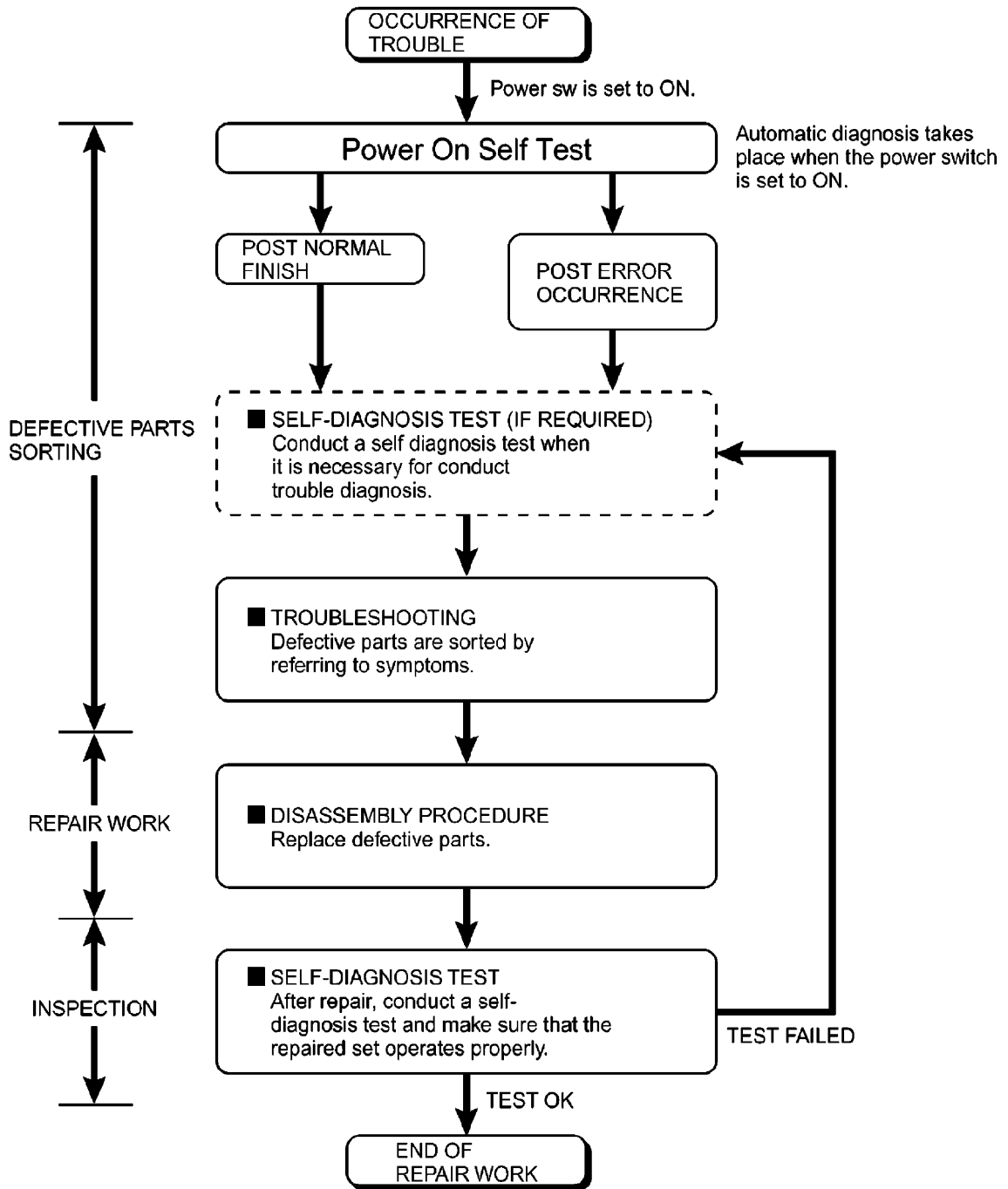

4.2. Troubleshooting

Please take note of the following two points with regard to troubleshooting:

1. Know-how of diagnosis upon occurrence of heavy troubles, e.g. 'Set cannot be turned ON', 'Set fails to start', 'No display on screen', etc.
2. Explanation of each trouble, mainly symptom of trouble in operation.

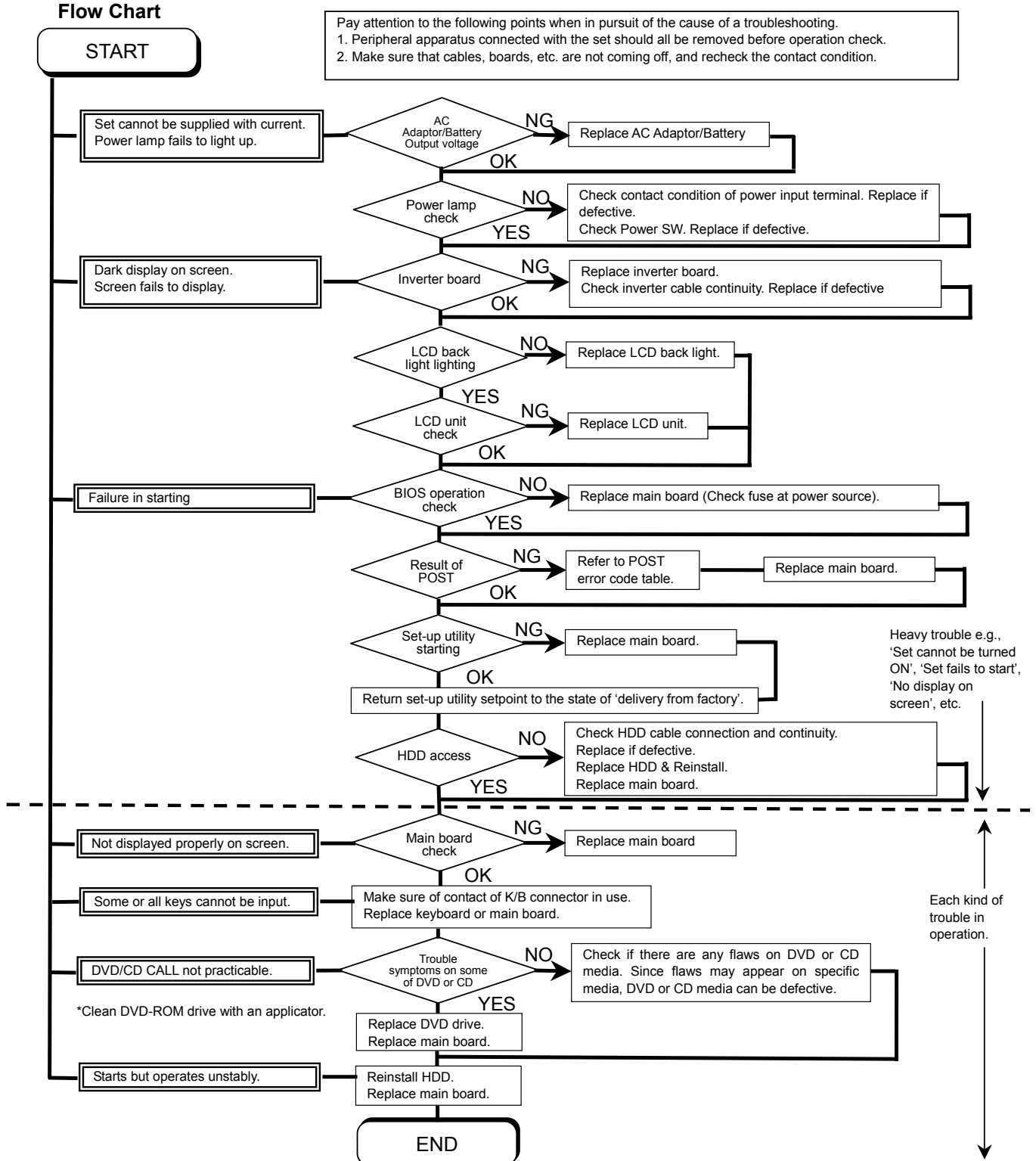

5 Power-On Self Test (Boot Check)

Outline of POST

The set has a boot check function called POST (Power-On Self Test) in it. The condition of the main body is diagnosed by checking beep sound or error code.

- StartTest begins automatically when power switch is set to ON.
- Normal finishAfter memory checking, a beep sound is issued once and the set is placed into automatic stop.

Note: If no error occurs, nothing is displayed. (No display of OK, etc.)

Error Diagnosis by Checking Beep Signal Sound

The beep sound is as follows:



(Length of bar shows length of sound.)

■ = long sound (about 0.4 sec.), ■ = short sound (about 0.2 sec.), Length between sounds is about 0.1 sec.

● Table of errors classified by beep sounds

Diagnosis	Beep signal sound	Error message
Main board	1(long sound)-2	BIOS ROM error
	1-2-2-3	BIOS ROM error
	1-3-1-1	RAM error
	1-3-1-3	Keyboard controller error
	1-3-4-1	RAM error
	1-3-4-3	RAM error
	1-4-1-1	RAM error
	2-1-2-3	BIOS ROM error
	2-2-3-1	Occurrence of unexpected offering

(Note) A beep sound is also issued in case of other I/O trouble.

6 List of Error Codes <Only when the port replicator is connected>

The following is a list of the messages that BIOS can display. Most of them occur during POST. Some of them display information about a hardware device, e.g., the amount of memory installed. Others may indicate a problem with a device, such as the way it has been configured. Following the list are explanations of the messages and remedies for reported problems. If your system displays one of except the messages marked below with an asterisk (*), write down the message and contact Panasonic Technical Support. If your system fails after you make changes in the Setup menus, reset the computer, enter Setup and install Setup defaults or correct the error.

0200 Failure Fixed Disk

Fixed disk in not working or not configured properly. Check to see if fixed disk is attached properly. Run Setup. Find out if the fixed-disk type is correctly identified.

0210 Stuck key

Stuck key on keyboard.

0211 Keyboard error

Keyboard not working.

0212 Keyboard Controller Failed

Keyboard controller failed test. May require replacing keyboard controller.

0213 Keyboard locked - Unlock key switch

Unlock the system to proceed.

0230 System RAM Failed at offset : *nnnn*

System RAM failed at offset *nnnn* of in the 64k block at which the error was detected.

0231 Shadow RAM Failed at offset : *nnnn*

Shadow RAM failed at offset *nnnn* of the 64k block at which the error was detected.

0232 Extended RAM Failed at offset : *nnnn*

Extended memory not working or not configured properly at offset *nnnn*.

0250 System battery is dead - Replace and run SETUP

The CMOS clock battery indicator shows the battery is dead. Replace the battery and run Setup to reconfigure the system.

***0251 System CMOS checksum bad - Default configuration used**

System CMOS has been corrupted or modified incorrectly, perhaps by an application program that changes data stored in CMOS. The BIOS installed Default SETUP Values. If you do not want these values, enter Setup and enter your own values. If the error persists, check the system battery or contact Panasonic Technical Support.

0260 System timer error

The timer test failed. Requires repair of system board.

0270 Real time clock error

Real-time clock fails BIOS test. May require board repair.

***0280 Previous boot incomplete - Default configuration used**

Previous POST did not complete successfully. POST loads default values and offers to run Setup. If the failure was caused by incorrect values and they are not corrected, the next boot will likely fail. On systems with control of **wait states**, improper Setup settings can also terminate POST and cause this error on the next boot. Run Setup and verify that the wait-state configuration is correct. This error is cleared the next time the system is booted.

0281 Memory Size found by POST differed from EISA CMOS

Memory size found by POST differed from EISA CMOS.

02D0 System cache error - Cache disabled

Contact Panasonic Technical Support.

02F0: CPU ID:

CPU socket number for Multi-Processor error.

02F4: EISA CMOS not writable

ServerBIOS2 test error: Cannot write to EISA CMOS.

02F5: DMA Test Failed

ServerBIOS2 test error: Cannot write to extended DMA (Direct Memory Access) registers.

02F6: Software NMI Failed

ServerBIOS2 test error: Cannot generate software NMI (Non-Maskable Interrupt).

02F7: Fail - Safe Timer NMI Failed

ServerBIOS2 test error: Fail-Safe Timer takes too long.

***device* address Conflict**

Address conflict for specified *device*.

Allocation Error for: *device*

Run ISA or EISA Configuration Utility to resolve resource conflict for the specified *device*.

Failing Bits : *nnnn*

The hex number *nnnn* is a map of the bits at the RAM address which failed the memory test.

Each 1 (one) in the map indicates a failed bit. See error 230,231 or 232 for offset address of the failure in System, Extended or Shadow memory.

Invalid System Configuration Data

Problem with NVRAM (CMOS) data.

I/O device IRQ conflict

I/O device IRQ conflict error.

Operating System not found

Operating system cannot be located on either drive A: or drive C:. Enter Setup and see if fixed disk and drive A: are properly identified.

Parity Check 1 *nnnn*

Parity error found in the system bus. BIOS attempts to locate the address and display it on the screen. If it cannot locate the address, it displays ????. Parity is a method for checking errors in binary data. A parity error indicates that some data has been corrupted.

Parity Check 2 *nnnn*

Parity error found in the I/O bus. BIOS attempts to locate the address and display it on the screen. If it cannot locate the address, it displays ????.

Press <F1> to resume, <F2> to Setup

Displayed after any recoverable error message. Press <F1> to start the boot process or <F2> to enter a Setup and change the settings. Write down and follow the information shown on the screen.

7 Self Diagnosis Test

As for the self-diagnosis test(PC-Diagnostic utility) to use this model, a standard test and the enhancing test by the module of the main body building in are possible.

Notes To skip BIOS password

Use <Ctrl>+<F10> key to skip BIOS password or authentication of fingerprint.

This key is only for entering DIAG mode. Not available to boot the computer.

If customer set "HDD Lock", the DIAG program cannot perform HDD test.

*This key is for service purpose only. Do not disclose this information to unrelated others.

1. Beginning of self-diagnosis test

1-1. Setting of content of setup

1. The power supply of the computer is turned on.
2. " F2 " is pushed on the screen of "Panasonic" while " press <F2 to enter Setup> " is displayed.
3. The setup utility starts and then takes notes of the content of the BIOS setup of present set.
4. " F9 " is pushed, " Yes" is selected on the screen of " Is the default value loaded? ", and " Enter" is pushed.
5. " F10 " is pushed.
6. " Yes" is selected on the screen of the setup confirmation, and " Enter" is pushed.
7. The computer starts automatically.

Attention

- If the device which can be set is set to "Invalidity" by "Advanced" or "Security" menu, becomes an error by "PC-Diagnostic utility".
(It is judged that the device which can be set to "Invalidity" by "Main" menu such as "Flat pad" is normal if the controller operates normally though sets to "Invalidity" by the setup.)
- In the model with built-in DVD of the USB connection, even if DVD is normal, becomes an error if legacy USB is set to "Invalidity"

1-2. When you execute an automatic test

1. "Ctrl" + "F7" is pushed while the "Panasonic" start screen is displayed after the computer is started.
2. The test of all devices begins automatically by "PC-Diagnostic utility" 's starting.

Attention

- It is a test which the customer who bought PC can execute. (As for HDD, the enhancing test is also possible.)
- A flat pad does not work for a while after starting "PC-Diagnostic utility".
- The movement of a flat pad might become abnormal If after RAM begins from the CPU/System test, a flat pad will be operated in about 30 seconds. In that case, restarts pushing "Alt" + "Ctrl" + "Del" key. Or, please start "PC-Diagnostic utility" again after doing the power supply switch in the slide, and turning off the power supply.

1-3. When you execute the enhancing test

1. Please let me discontinue diagnosing clicking  to end an automatic test.
2. Please click on the character of "D" "PC-Diagnostic utility" on the screen while pushing both of right "Shift" and left "Shift" keys.



3. All devices which can select the enhancing test make the setting of the enhancing test possible.
4. The district device is made "FULL" display (enhancing test).
5. The test begins clicking .

*Please refer to item 4 for the error result of each test and the division of the breakdown part.

2. Operation of PC-Diagnostic Utility

- Only the device which can be inspected on the entire screen is displayed.
- The item does not appear when the device of wireless LAN etc. is not physically connected.
- The movement of the item must use an arrow key or a flat pad.



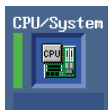

- As for the device under the diagnosis, blue and yellow are alternately displayed at the left of the icon.
- The diagnosis result of the device greens at the left of the icon when it is normal, and becomes red when abnormal.



- When the test of all devices ends, the test result is displayed under the right of the screen.



- Please click  while diagnosing when being stop on the way by the time the test of all devices ends.
- Please click  when you restart "PC-Diagnostic utility".
- *Each device is tested from the beginning, and it is not possible to restart on the way.
- When the test of all devices ends, the test result is displayed under the right of the screen.

2-1. Selection of tested device

- To test only a specific device, "Test" and "Do not test" of each device can be selected.
- The device which can select the enhancing test changes in order of "The standard is tested" and "Do not test" whenever the device icon is clicked.



Start the standard test



Do not test

Please begin testing clicking  if the selection of the tested device ends.

2-2. "PC-Diagnostic utility" End method

When of "Close" on the right of the screen is clicked, the computer reactivates automatically. Or, the power supply switch is done in the slide and the power supply is turned off.

2-3. The content of the setup is returned to the setting of the user

1. Turned on the computer.
2. "F2" is pushed on the screen while "Press<F2>to enter Setup" is displayed of "Panasonic".
3. Push "F10", and on the screen of "Is the change in the setting preserved and do end?"and then "Yes" is selected, and "Enter" is pushed.
4. The computer reactivates automatically.
5. The end option is chosen by the start menu, and the power supply of the computer is turned off.

Standard at test time

All devices other than RAM and HDD ----- about 1 minute
RAM standard test ----- 1 - 2 minutes
HDD standard test ----- 2 - 3 minutes
HDD enhancing test (60GB) ----- about 40 minutes

Ex.The standard when the standard <all device> is tested becomes $1+2+3=6$ minutes.

There is greatly a difference from RAM test when the memory is increased according to the performance of the memory occasionally.

Moreover, when the main body of PC under the test is a high temperature, it occasionally takes time.

There is greatly a difference from HDD according to the performance of the drive occasionally.

To skip BIOS password

Use <Ctrl>+<F10> key to skip BIOS password or authentication of fingerprint.
This key is only for entering DIAG mode. Not available to boot the computer.
If customer set "HDD Lock", the DIAG program cannot perform HDD test.

*This key is for service purpose only. Do not disclose this information to unrelated others.

8 Wiring Connection Diagram

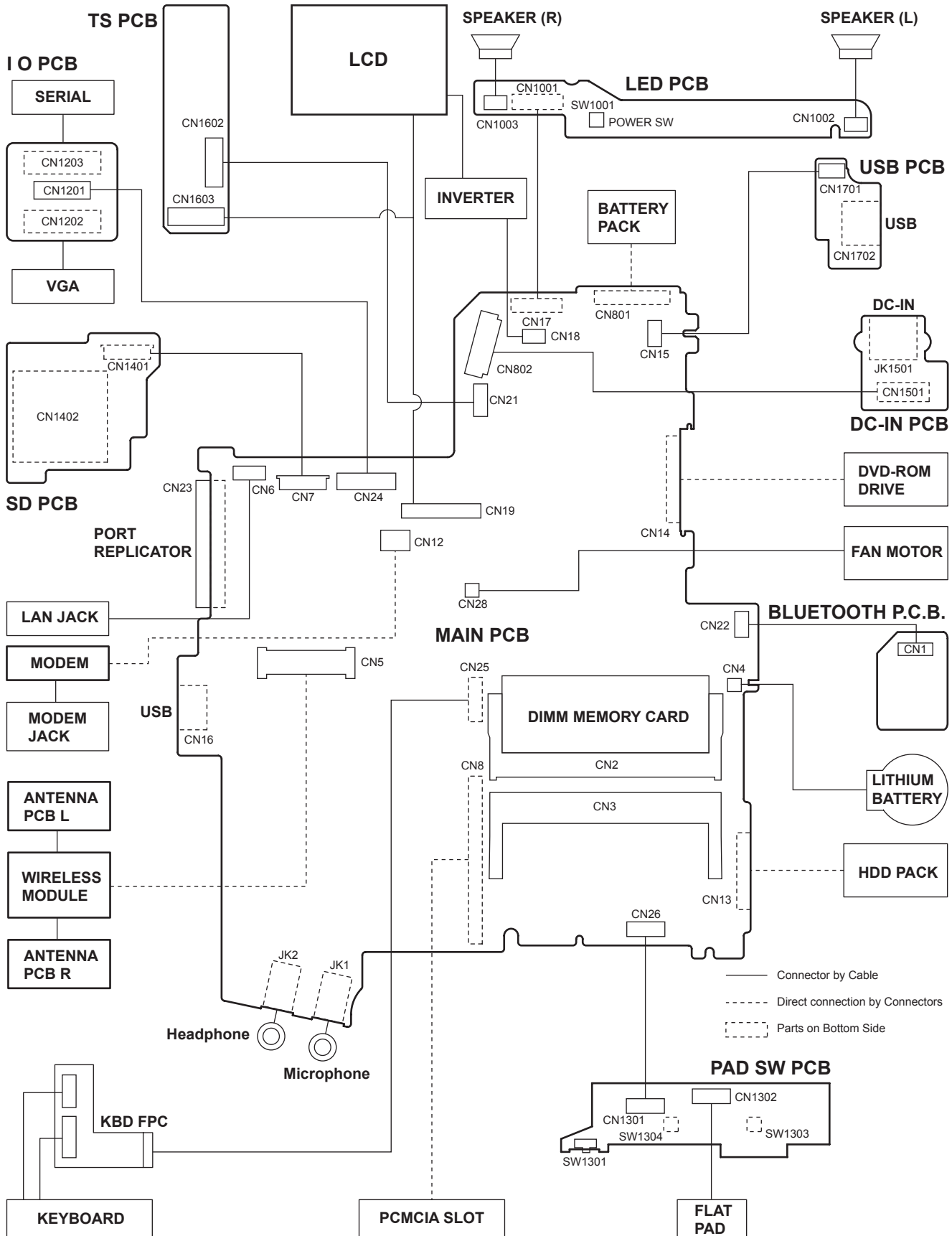

9 Disassembly/Reassembly

Note:

Power off the computer. Do not shut down to the Suspend or hibernation mode.

Do not add peripherals while the computer is in the Suspend or hibernation mode; abnormal operation may result.

9.1. Disassembly Instructions

9.1.1. Preparation

Before disassembling, be sure to make the following preparations.

- Shut down Windows and turn off the power.
- Disconnect the AC adaptor.
- Remove the optional DIMM memory card and PCMCIA card if they are connected.
- Remove other devices if they are connected.

Attention:

- Please execute writing BIOS ID when you exchange the Main Board.
- You cannot reuse the Conductive Clothes and the heat dissipating parts such as Sheet and Rubber. Use new parts.

9.1.2. Removing the Battery Pack, the HDD Unit and the DVD-ROM Drive Unit

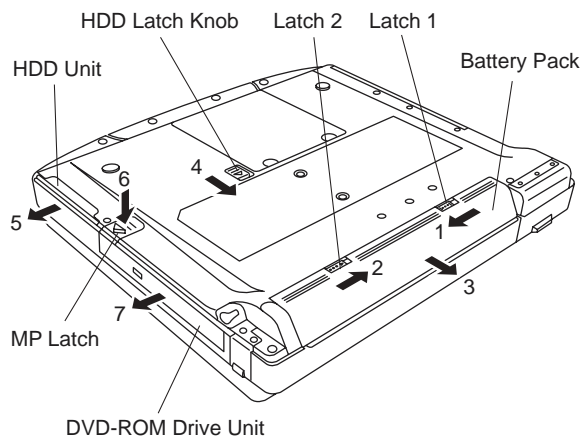

Battery Pack

1. Slide the Latch 1 to unlock. (1)
2. Slide the Latch 2 (2), and then without releasing it, slide and remove the Battery Pack. (3)

HDD Unit

1. Slide the HDD Latch Knob (4), and then without releasing it, slide and remove the HDD Unit. (5)

DVD-ROM Drive Unit

1. Push the MP Latch (6), and then without releasing it, slide the DVD-ROM Drive Unit. (7)

9.1.3. Removing the HDD

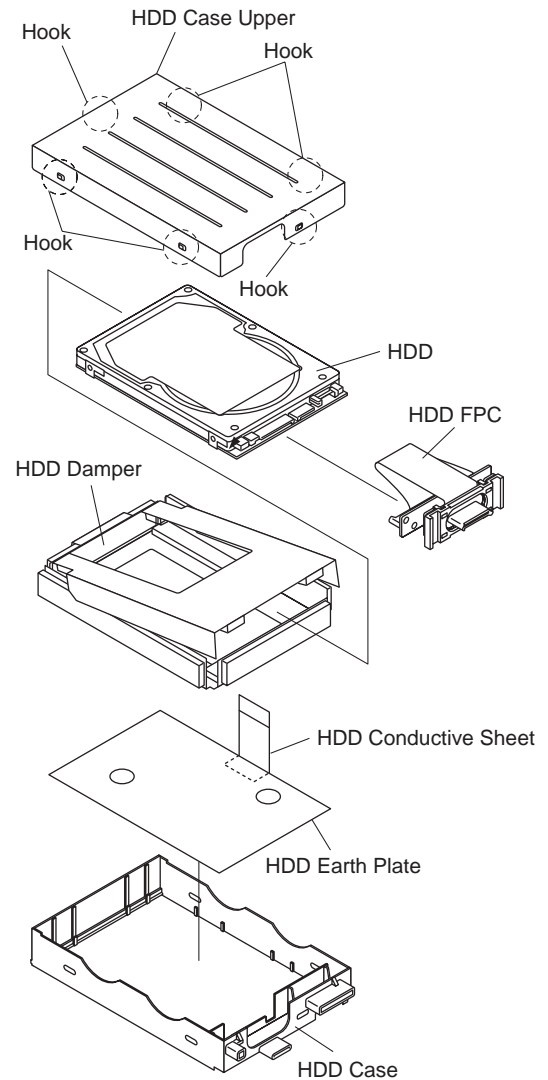

1. Remove the six Hooks, and remove the HDD Case Upper.
2. Remove the HDD Damper.
3. Disconnect the HDD from the HDD FPC.
4. Remove the HDD Conductive Sheet and HDD Earth Plate.

9.1.4. Removing the DIMM Memory Card

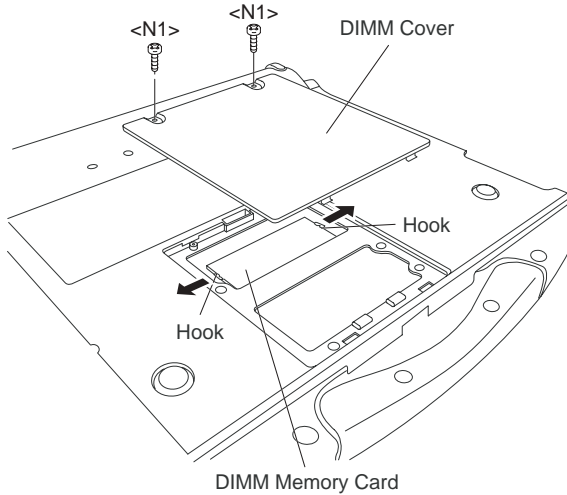

1. Remove the two Screws <N1>, and remove the DIMM Cover.
2. Open the right and left Hooks of the DIMM Memory Card outward, and remove the DIMM Memory Card.

Screws <N1>: XSB2+3FNL

9.1.5. Removing the Keyboard

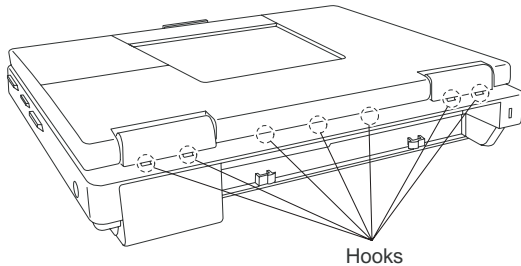

1. Release the seven Hooks fixing the rear side of the Center Cover.

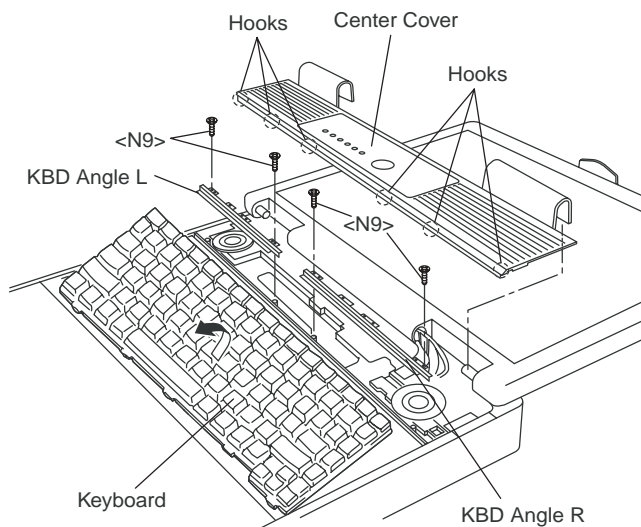

2. Lift the upper part of the Center Cover and draw it backward, release the six Hooks fixing the front side of the Center Cover, and then remove the Center Cover.
3. Remove the four Screws <N9> and the KBD Angle L and R.
4. Lift the upper part of the Keyboard and draw it backward, and then turn the Keyboard over forward.

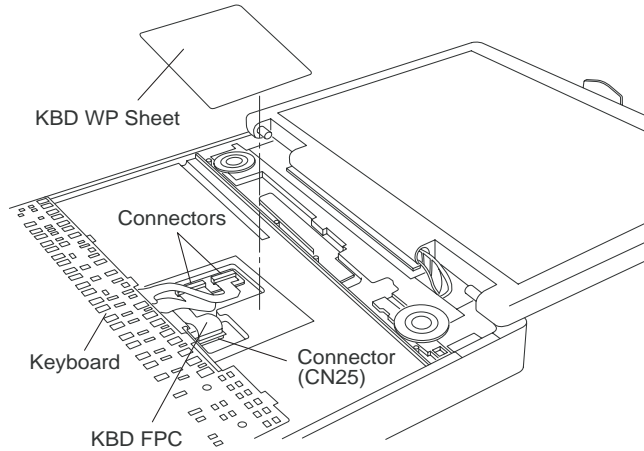

5. Remove the KBD WP Sheet.
6. Disconnect the two KBD Cables from the two Connectors (KBD FPC).
7. Remove the Keyboard.
8. Disconnect the Cable from the Connector (CN25).
9. Remove the KBD FPC.

Screws <N9>: DFHE5025XA

9.1.6. Removing the Speaker and the LED PCB

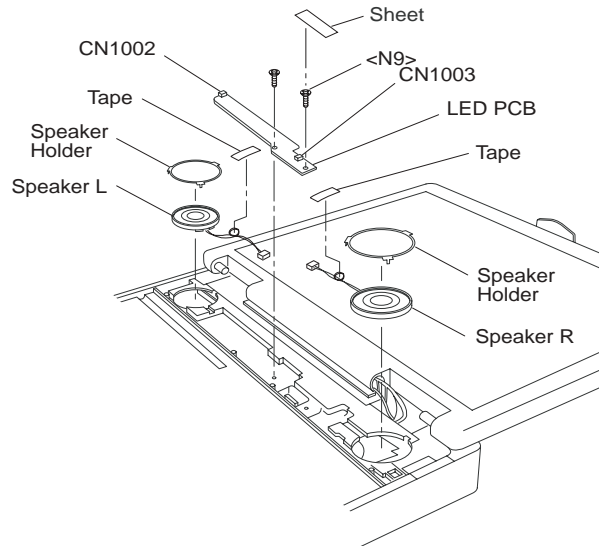

1. Remove the two Speaker Holders.
2. Remove the two tapes, and disconnect the two Speaker Cables from the two Connectors (CN1002, CN1003)
3. Remove the Speaker L and R.
4. Remove the Sheet.
5. Remove the two Screws <N9>, and Remove the LED PCB.

Screws <N9>: DFHE5025XA

9.1.7. Removing the Handle Ass'y

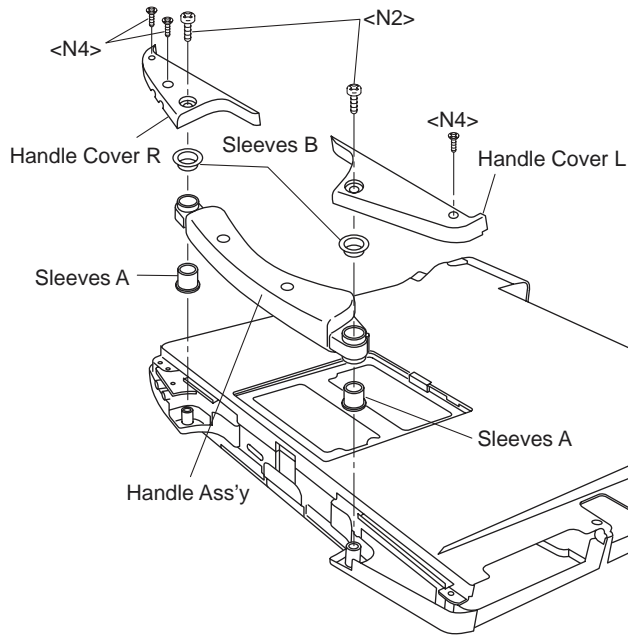

1. Remove the two Screws <N2>.
2. Remove the three Screws <N4>, and remove the Handle Cover L and R.
3. Remove the two Sleeves A, Handle Ass'y and two Sleeves B.

Screws <N2>: DRHM4+10FKS

Screws <N4>: DRSB2+6FKL

9.1.8. Removing the Bottom Case

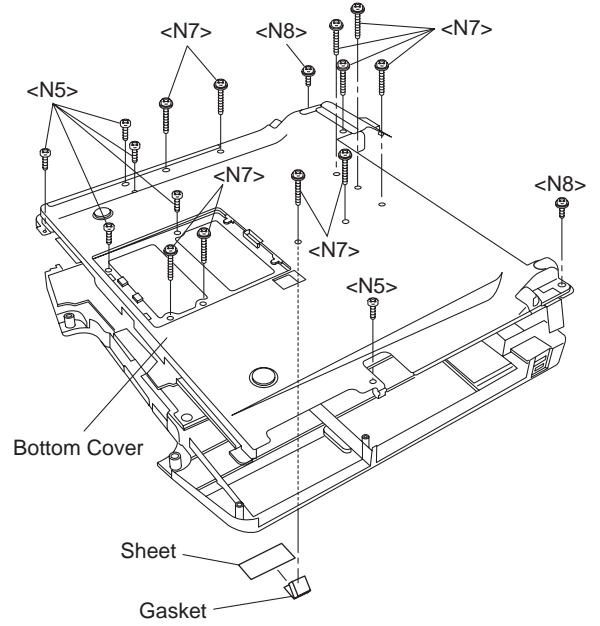

1. Remove the six Screws <N5>.
2. Remove the ten Screws <N7>.
3. Remove the two Screws <N8>.
4. Open the Lid Rubbers and remove the Bottom Cover.
5. Remove the Sheet and Gasket.

Screws <N5>: DXSB2+6FNL

Screws <N7>: DXYN2+J16FNL

Screws <N8>: DXYN2+J8FNL

9.1.9. Removing the Wireless Module and MDC Module

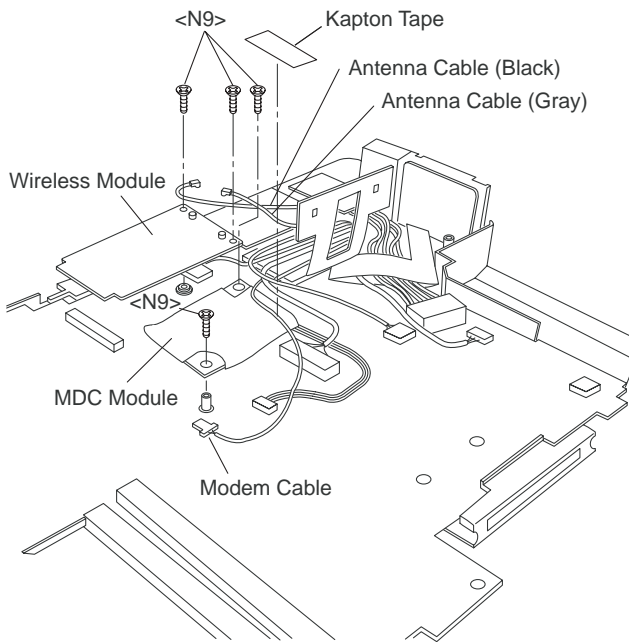

1. Remove the two Antenna Cables from the two Connectors.
 - Antenna Cable (Black): MAIN Connector
 - Antenna Cable (Gray): AUX Connector
2. Remove the two Screws <N9>.
3. Remove the Wireless Module.
4. Remove the two Screws <N9>.
5. Disconnect the Modem Cable from the Connector.
6. Remove the Kapton tape and remove the MDC Module.

Screws <N9>: DFHE5025XA

9.1.10. Removing the Main PCB

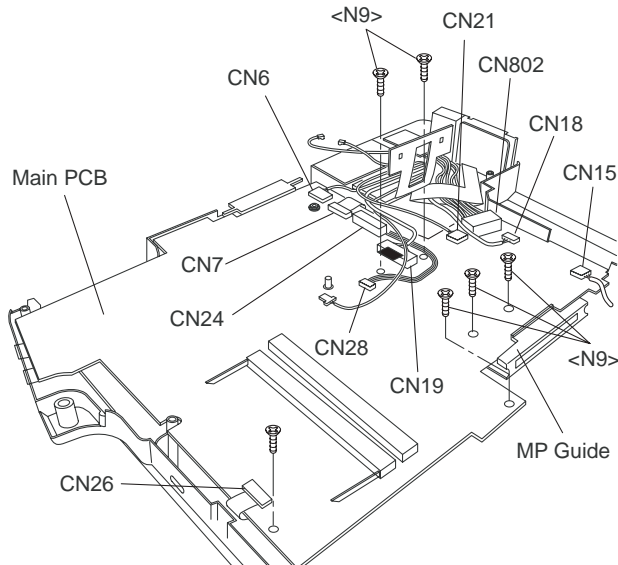

Note:

After replacing the Main Board, rewrite the BIOS ID.

1. Disconnect the ten Cables from the ten Connectors (CN6, CN7, CN24, CN19, CN28, CN21, CN802, CN18, CN15, CN25).
2. Remove the six Screws <N9>.
3. Remove the Main PCB.
4. Remove the MP Guide.

Screws <N9>: DFHE5025XA

9.1.11. Removing the PC Card Ejector and Lithium Battery

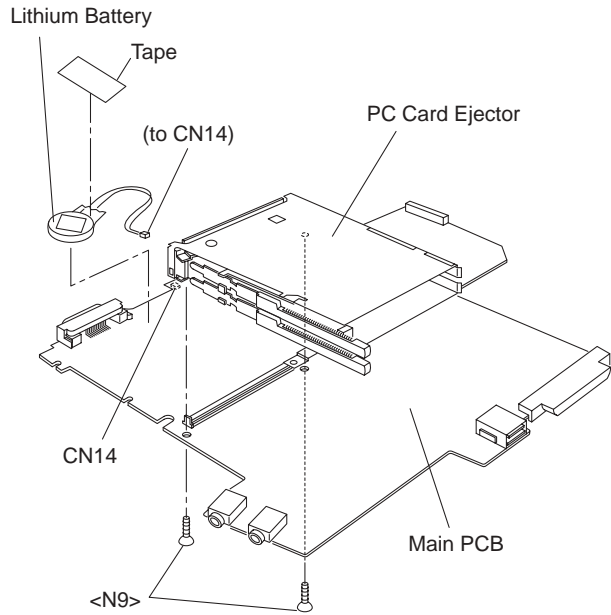

1. Remove the two Screws <N9>.
2. Remove the PC Card Ejector.
3. Disconnect the Cable from the Connector (CN14).
4. Remove the Lithium Battery.

Screws <N9>: DFHE5025XA

9.1.12. Removing the DC-IN PCB and I/O PCB

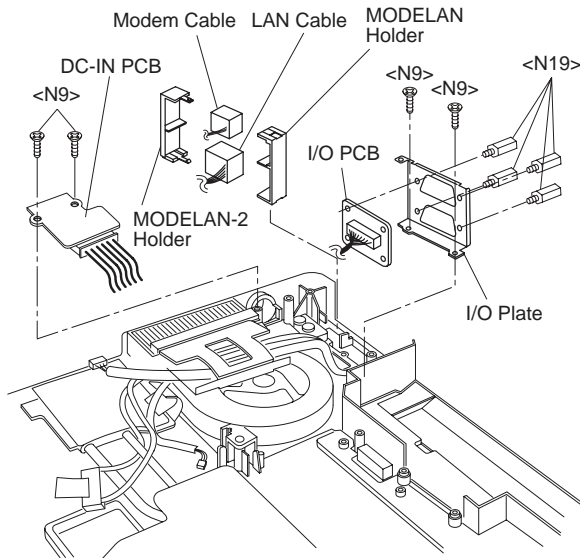

1. Remove the two Screws <N9>.
2. Remove the DC-IN PCB.
3. Remove the two Screws <N9>.
4. Remove the four Screws <N19>, and then the I/O PCB from the I/O Plate.
5. Remove the Modem Cable and LAN Cable from the MODELAN Holders.

Screws <N9>: DFHE5025XA
 Screws <N19>: DFHE5035ZB

9.1.13. Removing the FAN Motor and SD PCB

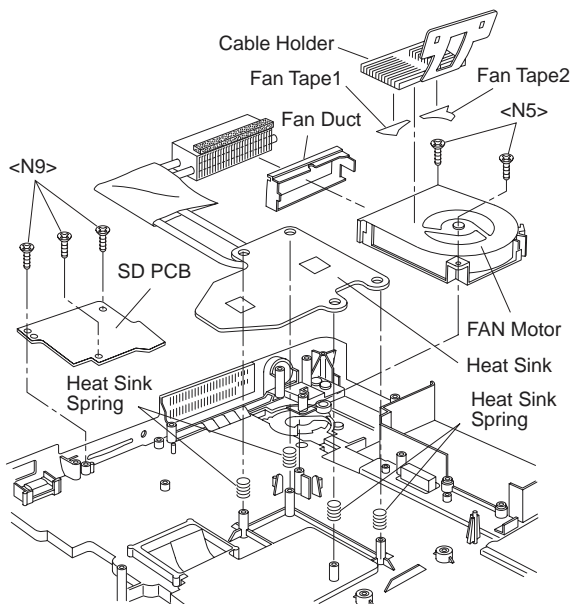

1. Remove the Cable Holder.
2. Remove the two Screws <N5>.
3. Remove the FAN Motor.
4. Remove the Heat Sink, Fan Duct, and the four Heat Sink

- Springs.
 5. Remove the three Screws <N9>.
 6. Remove the SD PCB.

Screws <N5>: DXSB2+6FNL
 Screws <N9>: DFHE5025XA

9.1.14. Removing the BT PCB

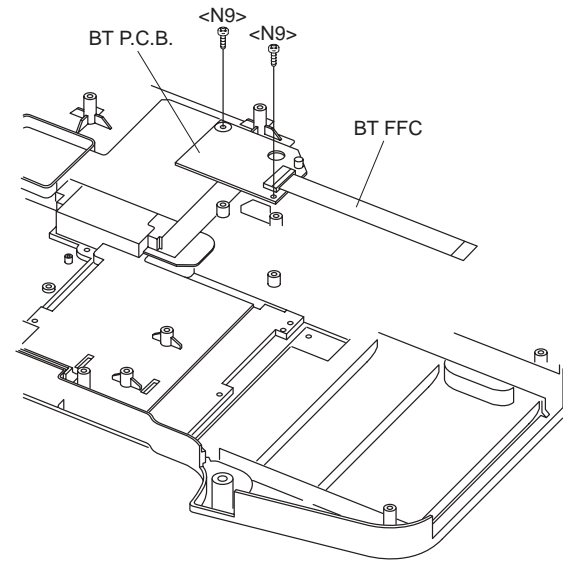

1. Remove the two Screws <N9>.
2. Remove the BT FFC from the Connector (CN2) and remove the BT PCB.

9.1.15. Removing the USB PCB

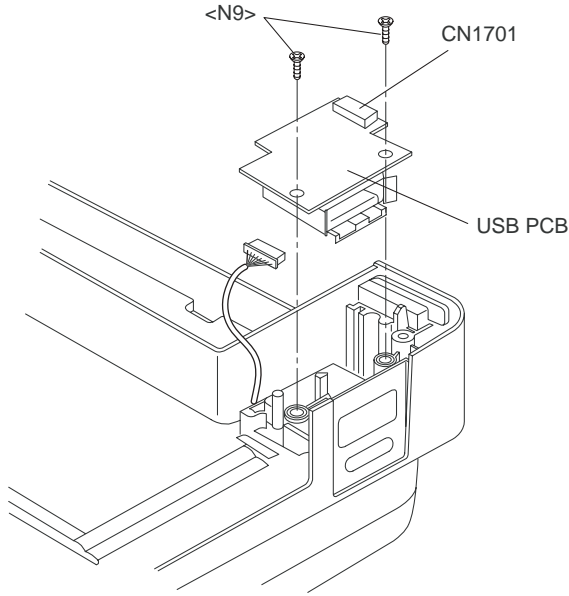

1. Disconnect the Cable from the Connector (CN1701).
2. Remove the two Screws <N9>.
3. Remove the USB PCB.

Screws <N9>: DFHE5025XA

9.1.16. Removing the Display unit

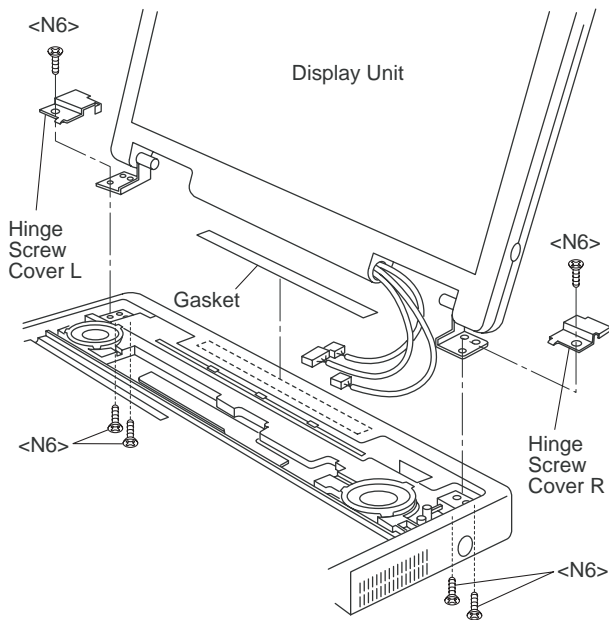

1. Remove the four Screws <N6> from the computer bottom side.
2. Remove the two Screws <N6> from the computer upper side.
3. Remove the Display Unit.
4. Remove the Hinge Screw Cover L and R.
5. Remove the Gasket.

Screws. <N6>: DXSB3+6FNL

9.1.17. Removing the LCD Front Cabinet

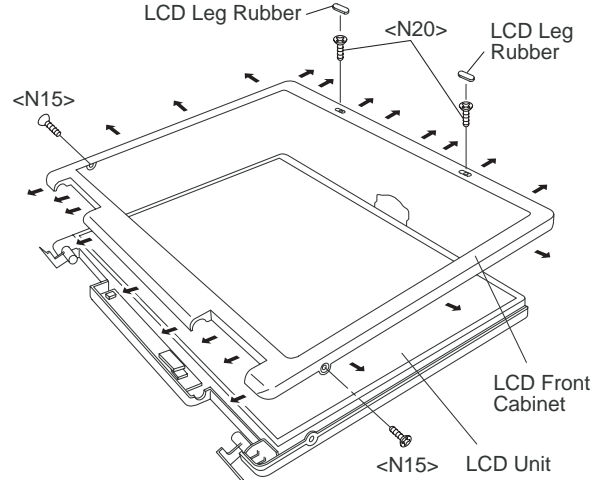

1. Remove the two LCD Leg Rubbers, and then the two Screws <N20>.
2. Remove the two Screws <N15>.
3. Release the 23 Hooks joining the LCD Front and Rear Cabinet on the LCD Front Cabinet outward. (See the Figure),
4. Remove the LCD Front Cabinet.

Screws <N15>: DRHM0075ZA

Screws <N20>: DXQT2+G4FCL

9.1.18. Removing the LCD and the Inverter

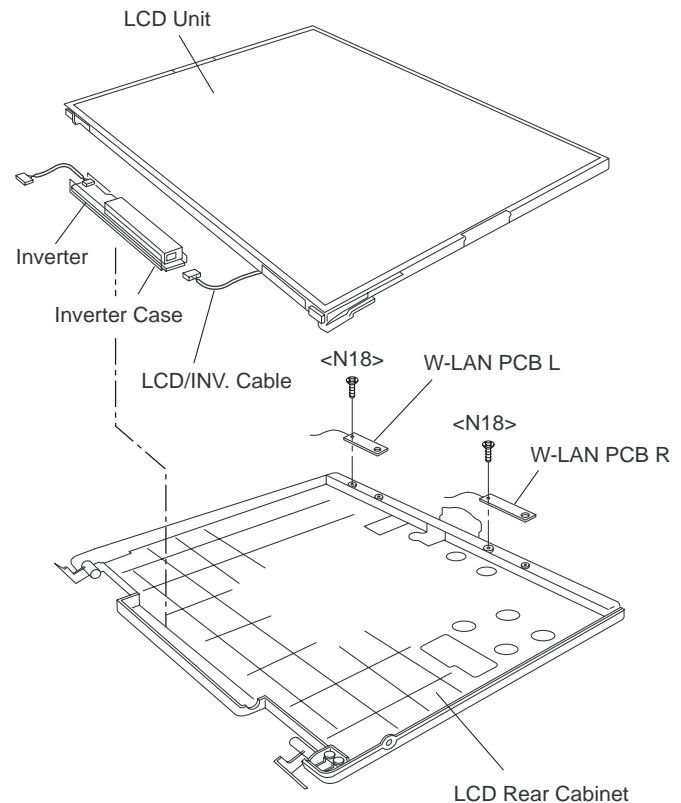

1. Disconnect the LCD/INV. Cable from the Connector on the Inverter.
2. Remove the LCD Unit.
3. Remove the Inverter with the Inverter Case.
4. Remove the two Screws <N18>, and then the W-LAN PCB L and R.

Screws <N18>: XQN17+BJ6FJ

9.1.19. Removing the Touch PAD and PAD PCB

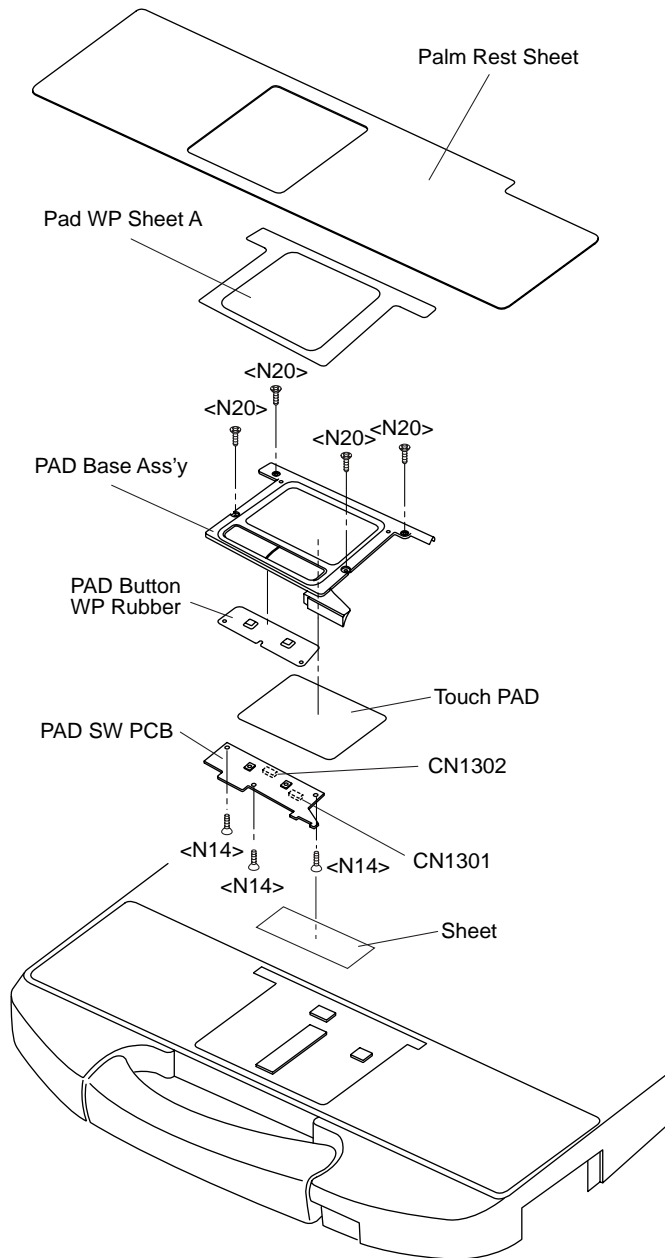

1. Remove the Palm Rest Sheet.
2. Remove the four Screws <N20>, and then PAD Base Ass'y.
3. Disconnect the two Cables from the two Connectors (CN1301, CN1302).
4. Remove the three Screws <N14>.
5. Remove the PAD Button WP Rubber and PAD SW PCB.
6. Remove the Touch PAD.

Screws <N14>: DRHM0106ZA

Screws <N20>: DXQT2+G4FCL

9.1.20. Removing the Finger PCB

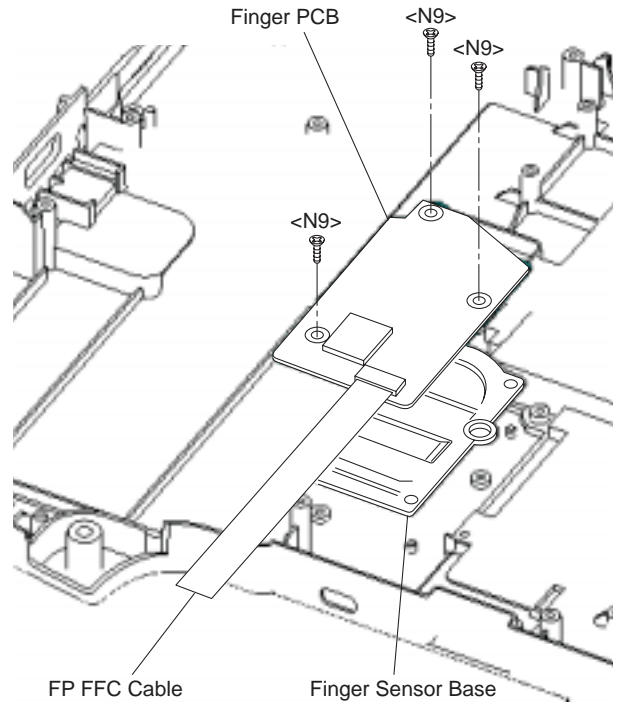

Preparation

Perform the steps up to removing of the Main PCB.

1. Remove the three Screws. <N9>
2. Remove the Finger PCB and Finger Sensor Base.

Screws <N9>: DFHE5025XA

9.2. Reassembly Instructions

9.2.1. Attention when CF-74 series is repaired

- Please execute writing BIOS ID when you exchange the Main Board.
- You cannot reuse the Conductive Clothes and the heat dissipating parts such as Sheet and Rubber. Use new parts.

9.2.2. Setting the Finger PCB

1. Fix the Finger PCB and the Finger Sensor Base to the computer using the 3 Screws <N9>.
2. Connect the FP FFC Cable to the Connector (CN27) on the Main PCB.

Screws <N9>: DFHE5025XA

■ Preparing and setting the Finger Sensor Base

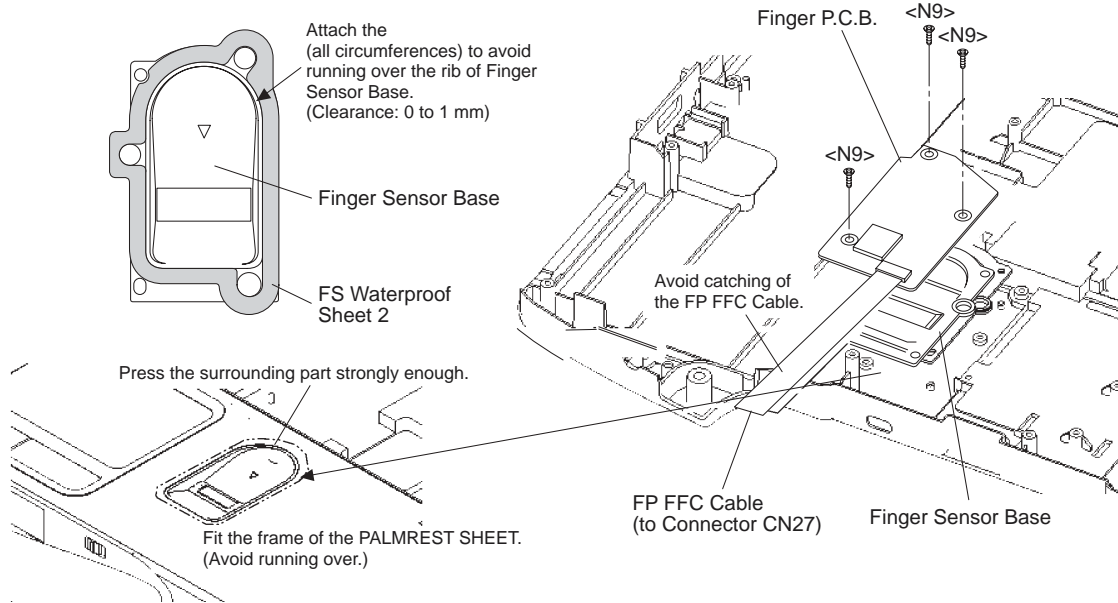

9.2.3. Setting the LCD Unit and the Inverter

1. Fix the W-LAN PCB L and R to the LCD Rear Cabinet using the two Screws <N18>.
2. Attach the Inverter with the Inverter Case to the LCD Rear Cabinet.
3. Set the LCD Unit to the LCD Rear Cabinet.
4. Connect the LCD/INV. Cable to the Connector on the Inverter.

Screws <N18>: XQN17+BJ6FJ

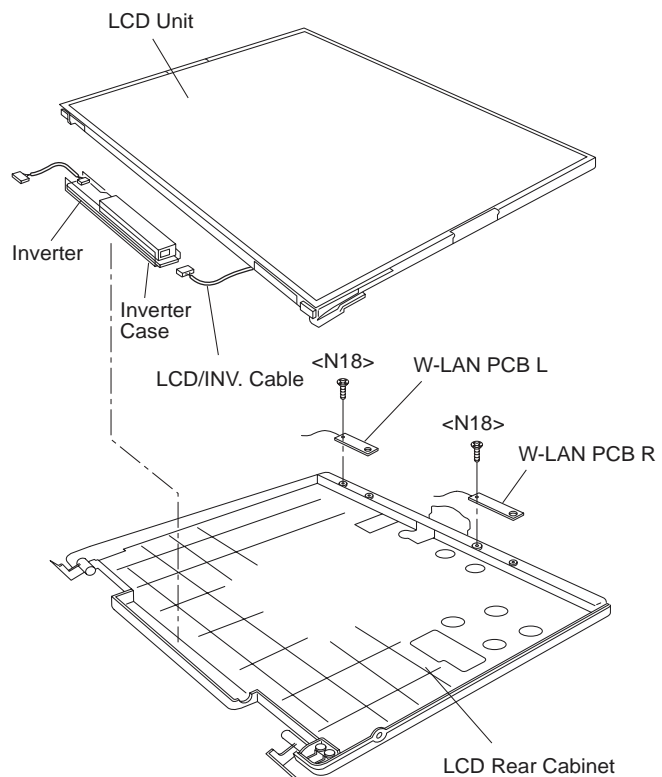

Arranging the W-LAN L and R Cable

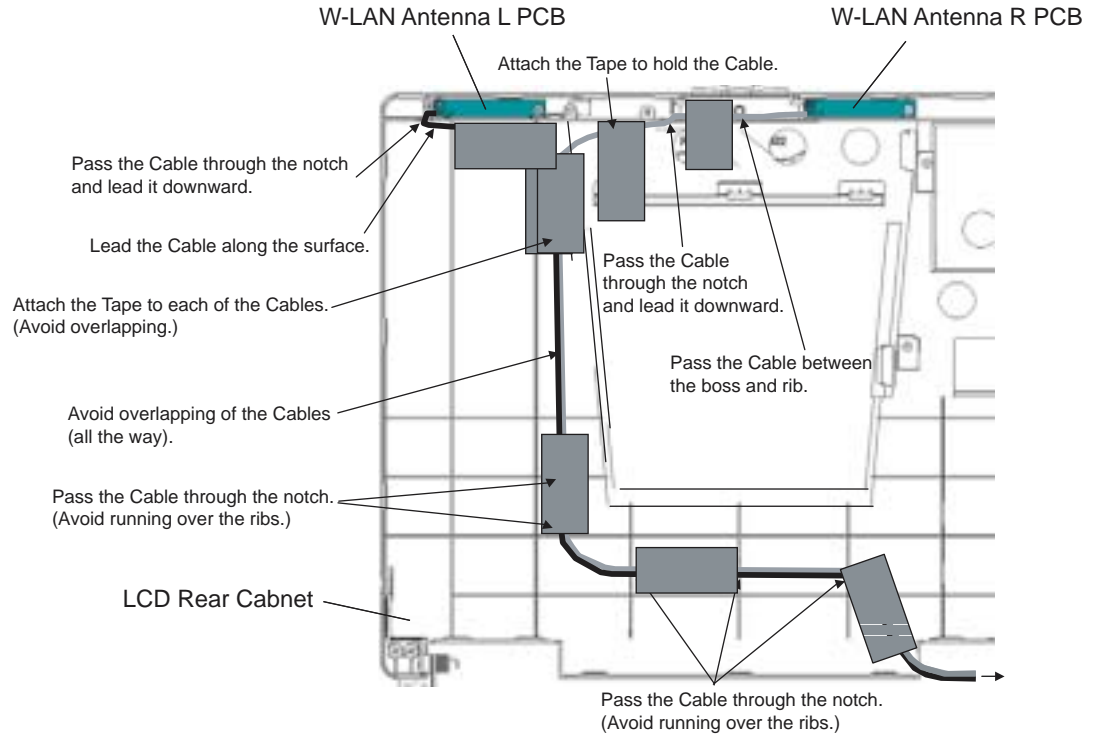

Attaching the LCD Damper C and LCD Damper D

1. Attach the four LCD Damper C to the upper part and lower part of the LCD Unit.
2. Attach the LCD Damper D to the upper center of the LCD Unit.

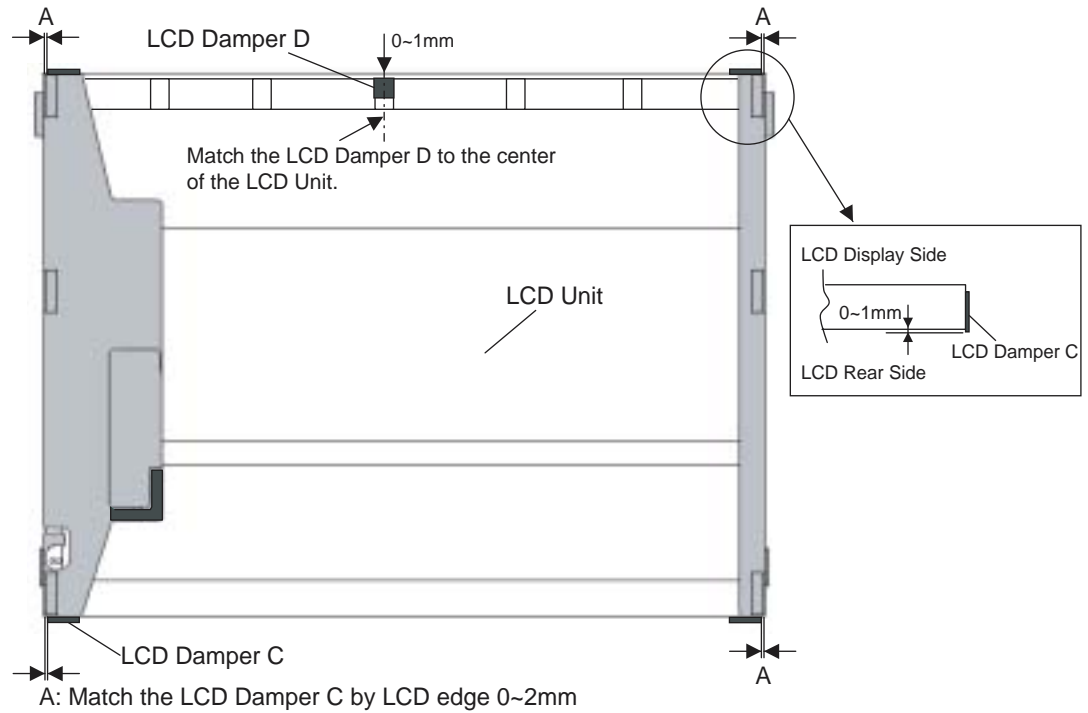

Arranging the LCD/TS Cable

1. Connect the LCD/TS Cable (LCD) to the Connector on the LCD Unit.
2. Connect the LCD/TS Cable (TS) to the Connector (CN603) on the TS PCB.

B: Attaching the Cloth

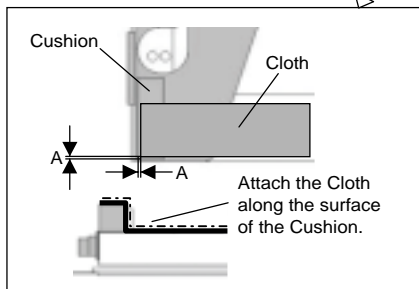
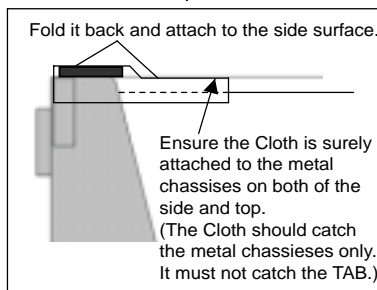
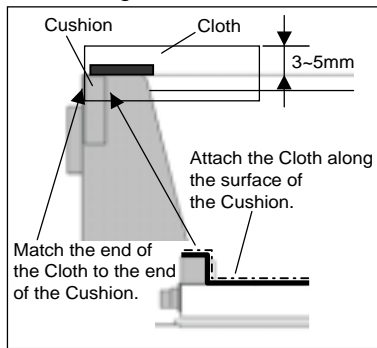

A: Match the Cloth by Cushion edge 0~1mm

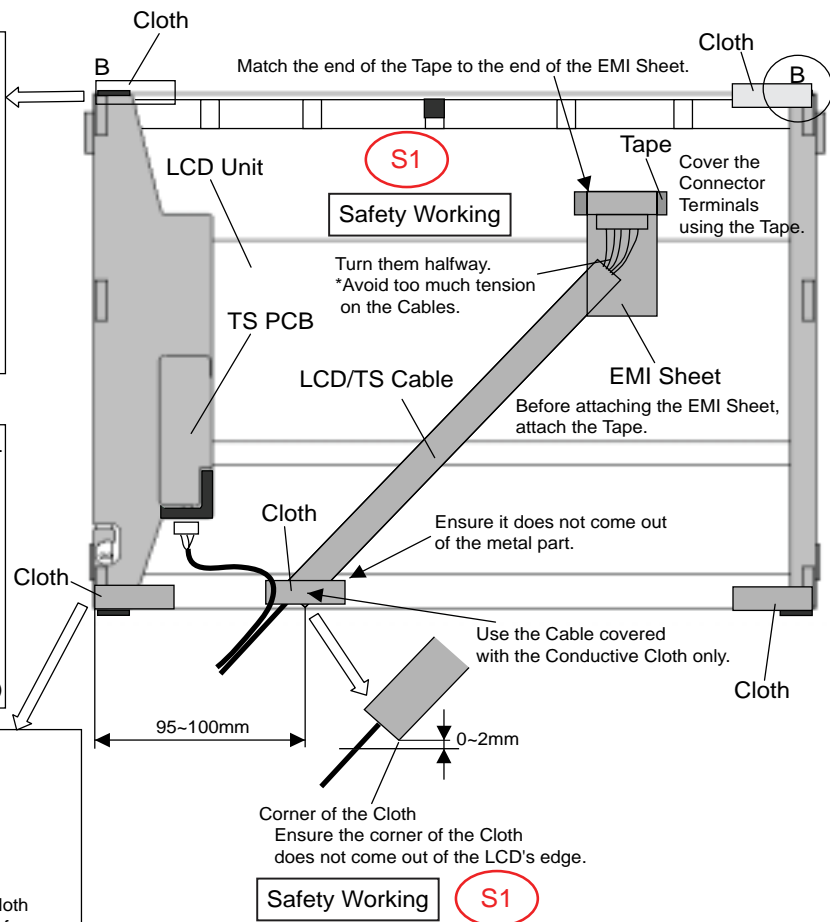

Arranging the TP Power Cable and Attaching the TP/LCD Sheet

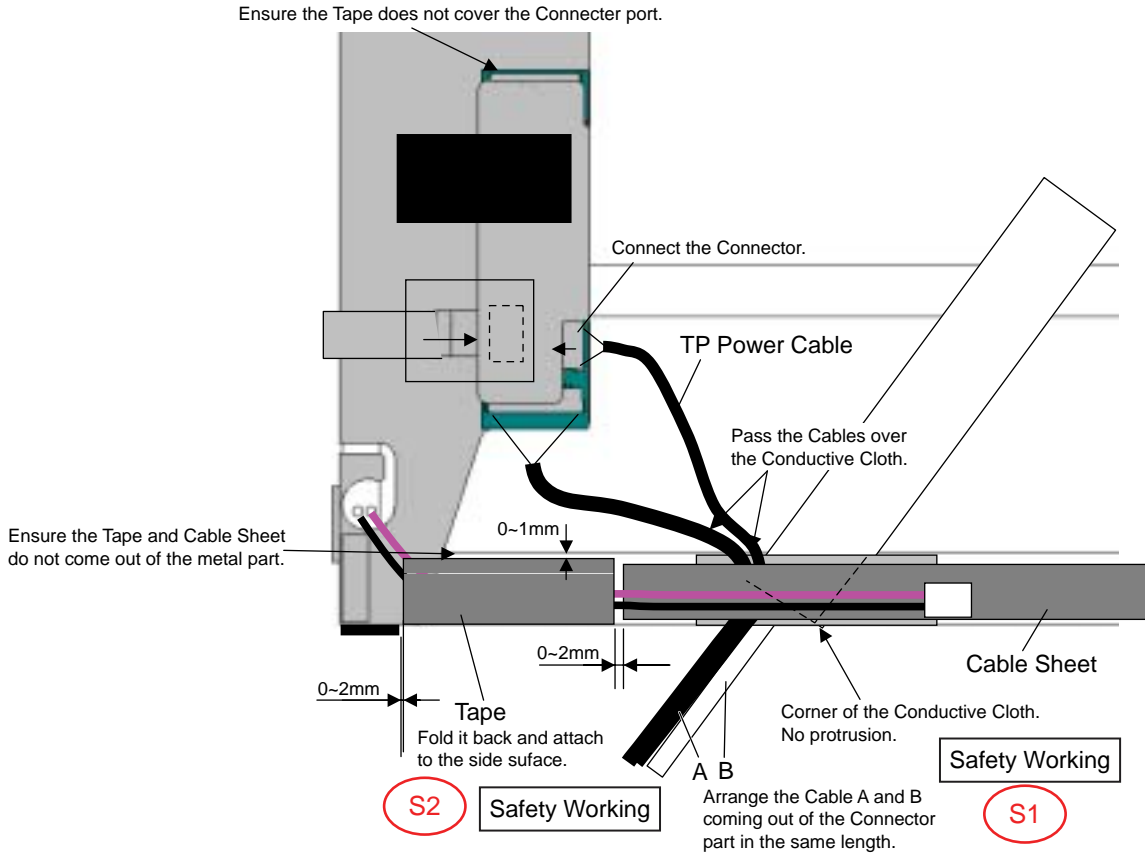

Setting the Inverter and Arranging the Inverter Cable

1. Insert the Inverter to the Inverter Case, and connect the Inverter Cable to the Connector on the Inverter.
2. Fix the Connector of the Inverter Cable using the Tape.

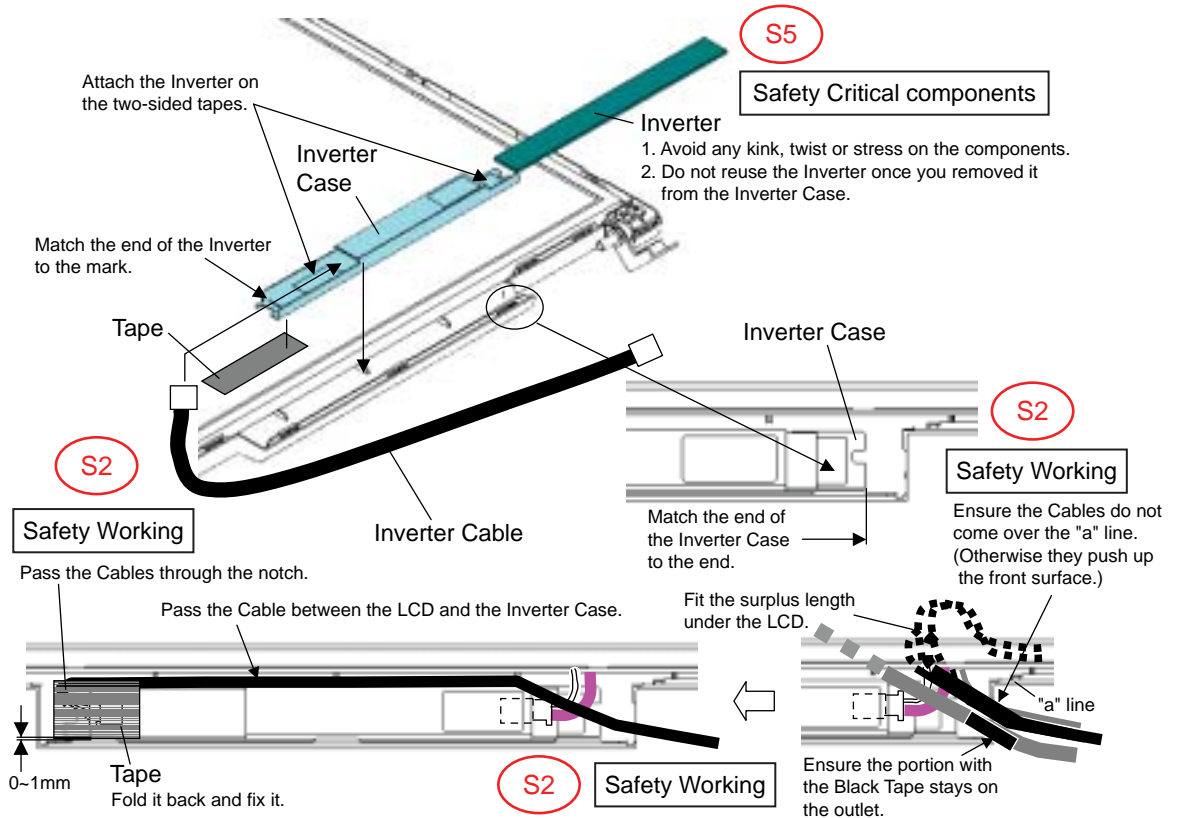

Cautions for Setting the LCD Unit

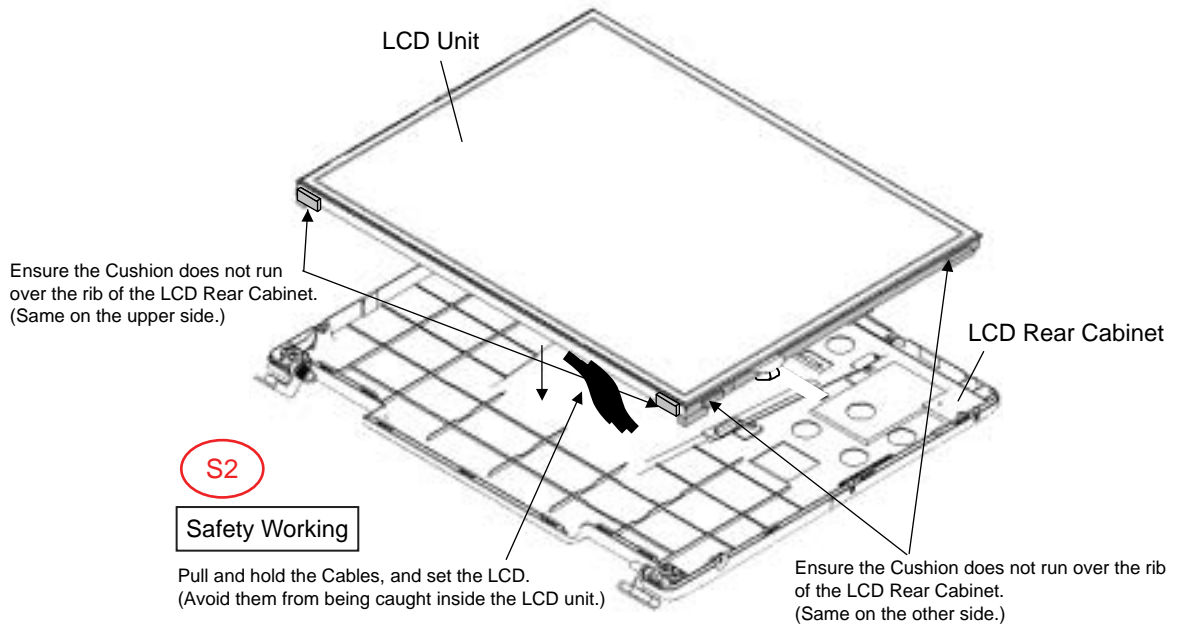

9.2.4. Setting the LCD Front Cabinet

1. Set the LCD Front Cabinet to the LCD Rear Cabinet.
2. Fix the LCD Front Cabinet using the two Screws<N15>.
3. Fix the LCD Front Cabinet using the two Screws<N16>, and attach the two LCD Leg Rubbers.

Screws <N15>: DRHM0075ZA

Screws <N16>: DXQT2+G4FCL

Fixing of the LCD Front Cabinet

Ensure all the 23 Hooks are securely set in.

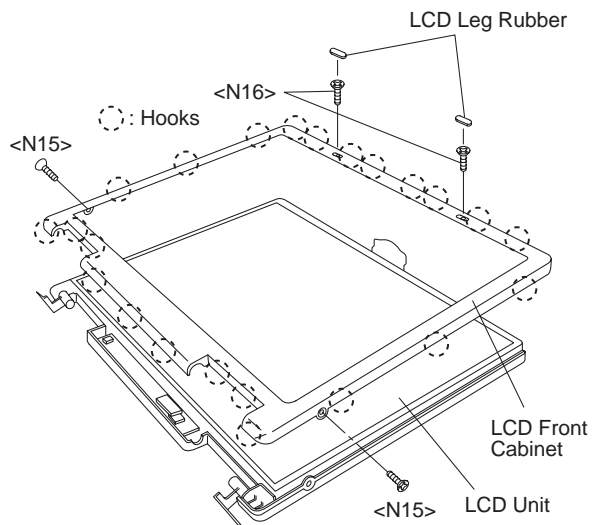

9.2.5. Setting the Display unit

1. Attach the Gasket.
2. Set the Hinge Screw Cover L and R to the Hinge L and R.
3. Pass the Cables coming out of the LCD Unit into the computer.
4. Fix the Display Unit using the two Screws<N6> from the computer upper side.
5. Fix the Display Unit using the four Screws<N6> from the computer bottom side.

Screws. <N6>: DXSB3+6FNL

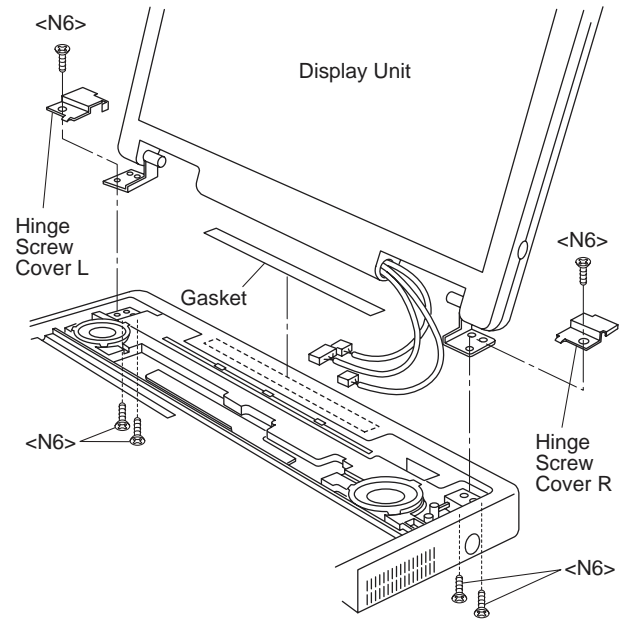

9.2.6. Setting the USB PCB

1. Fix the USB PCB to the computer using the two Screws<N9>.
2. Connect the USB Cable to the Connector (CN1701).

Screws <N9>: DFHE5025XA

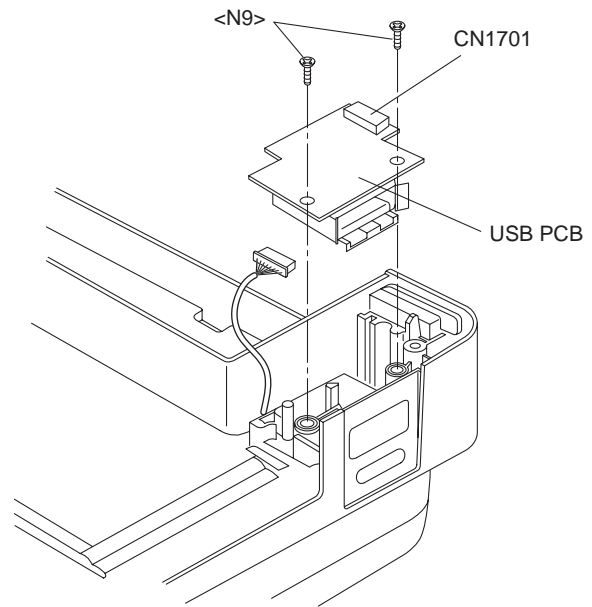

Arranging the USB Cable

Safety Working

S2

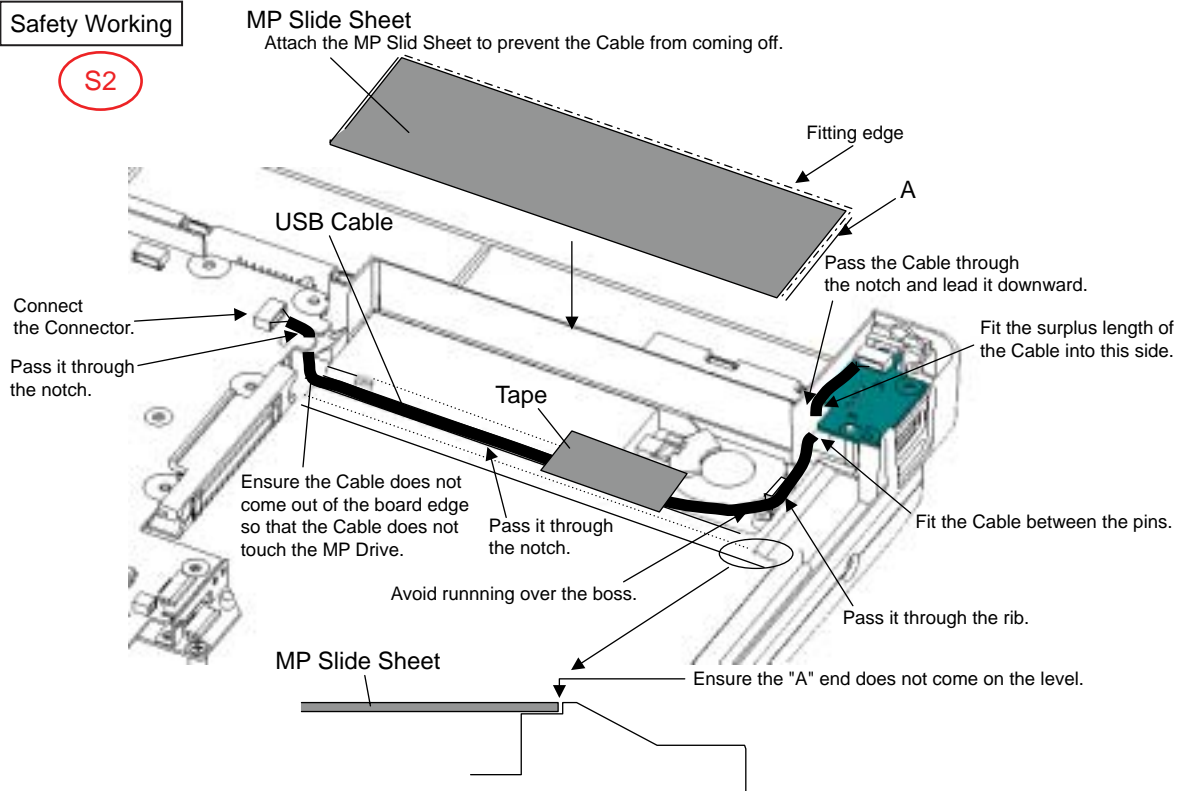

9.2.7. Setting the BT PCB.

1. Connect the BT FFC to the Connector (CN22).
2. Fix the BT PCB to the computer using the two Screws <N9>.

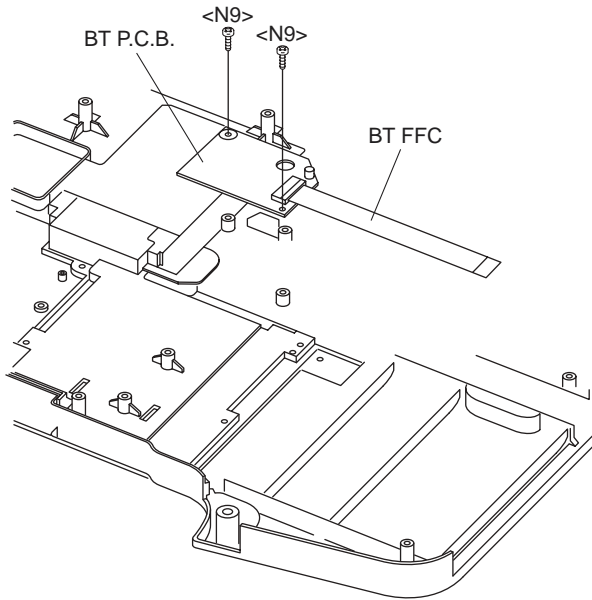

9.2.8. Setting the SD PCB, Heat Sink and FAN Motor

1. Connect the SD FFC to the Connector (CN1401).
2. Fix the SD PCB to the computer using the three Screws<N9>.
3. Set the Heat Sink, Fan Duct and the four Heat Sink Springs.
4. Fix the FAN Motor to the computer using the two Screws<N5>.
5. Attach the Fan Tape 1 and 2 on the FAN Motor, and fix the Cable Holder on them.

Screws <N5>: DXSB2+6FNL

Screws <N9>: DFHE5025XA

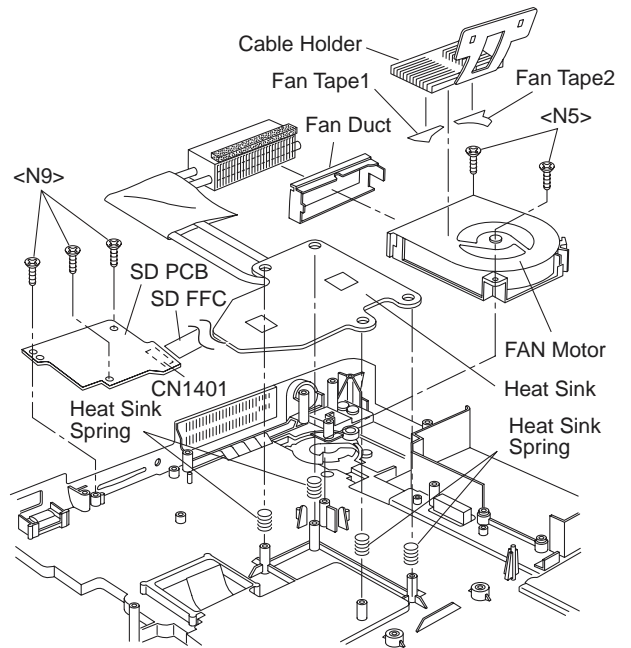

Applying Grease on the Heat Sink

1. Apply grease on two points of the Heat Sink.
2. Attach the Pipe Sheet on the Heat Pipe.

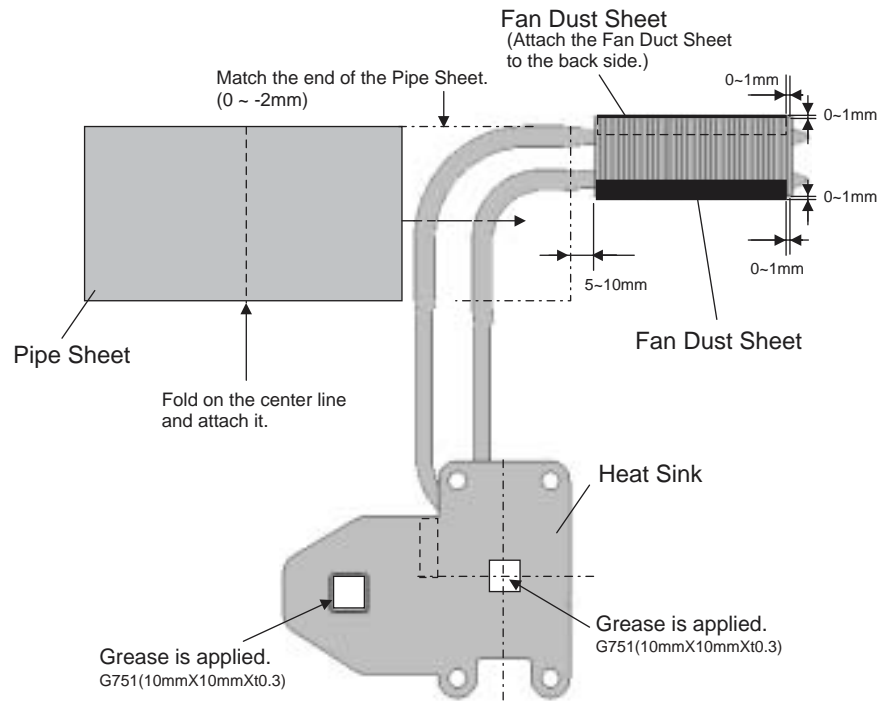

9.2.9. Setting the DC-IN PCB and I/O PCB

1. Fit the Modem Cable and LAN Cable between the MODELAN Holders, and set them on to the computer.
2. Fix the I/O PCB to the I/O Plate using the four Screws<N19>.
3. Fix the I/O PCB with I/O Plate to the computer using the two Screws<N9>.
4. Fix the DC-IN PCB to the computer using the two Screws<N9>.

Screws <N9>: DFHE5025XA
 Screws <N19>: DFHE5035ZB

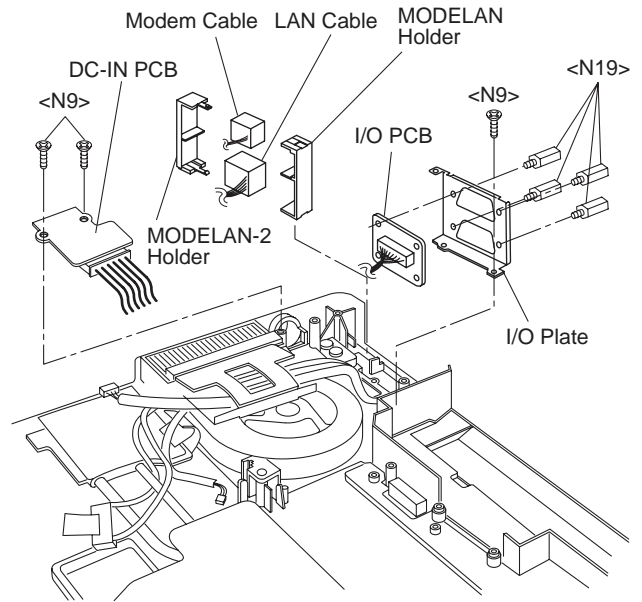

Arranging the DC-IN Cable

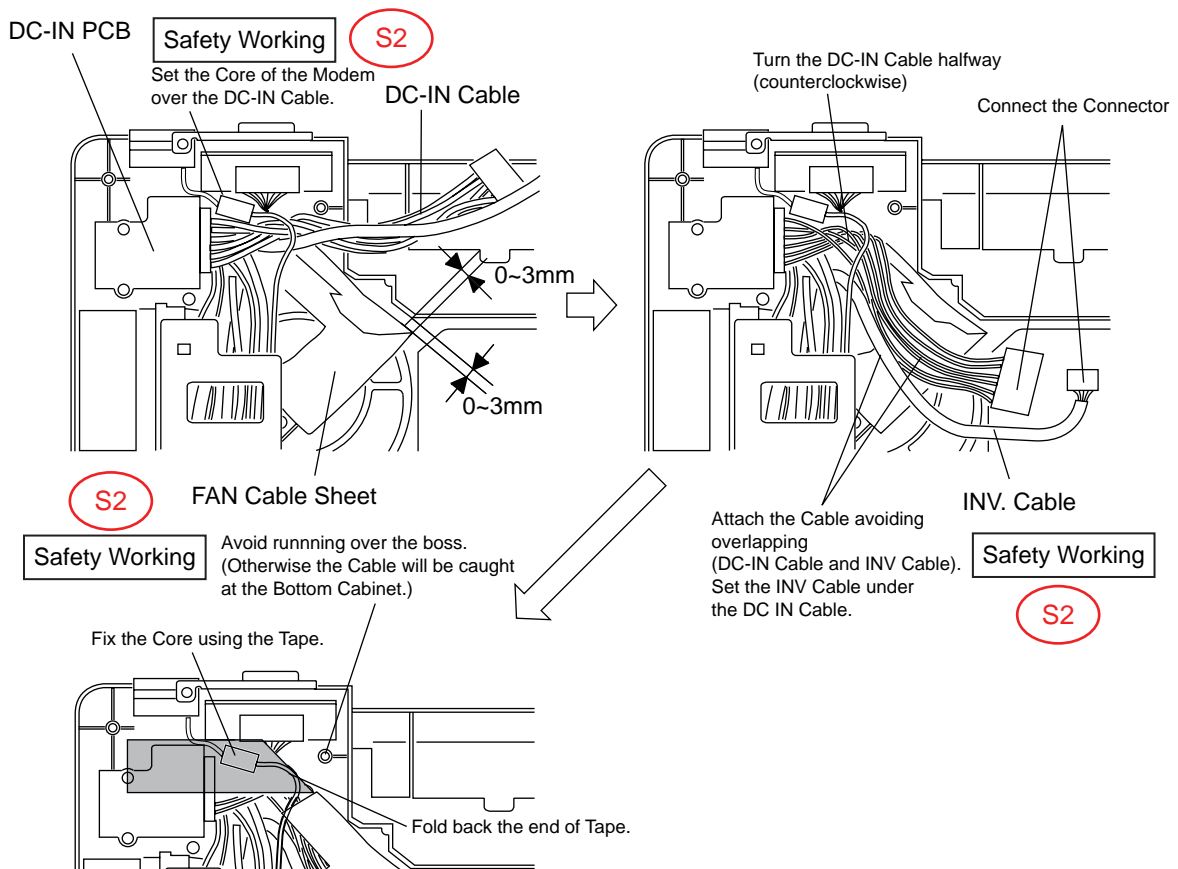

9.2.10. Setting the PC Card Ejector and Lithium Battery

1. Attach the Lithium Battery to the Main PCB.
2. Pass the Lead Wire of the Lithium Battery through the groove of the Main PCB, and connect it to the Connector (CN14) on the back side.
3. Fix the PC Card Ejector to the Main PCB using the two Screws<N9>.

Screws <N9>: DFHE5025XA

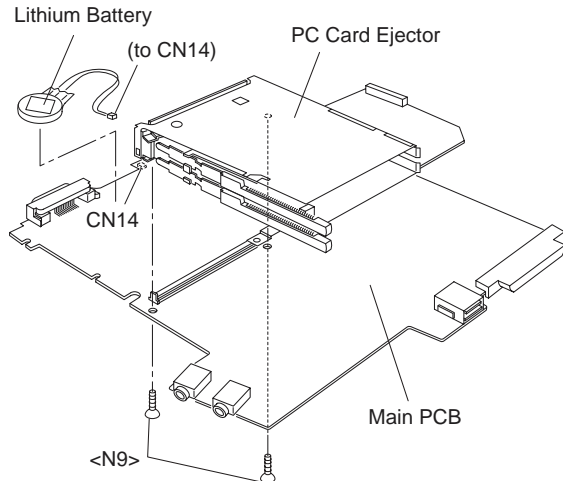

Arranging the Lithium Battery

Safety Working

S2

Pass the Cable through the groove of the Main PCB.

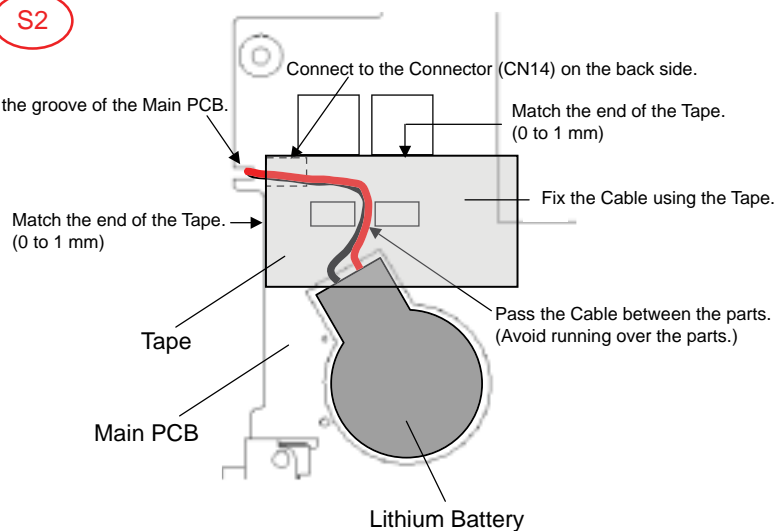

9.2.11. Setting the Main PCB

Note:

- After replacing the Main Board, rewrite the BIOS ID.
1. Set the MP Guide to the Main PCB.
 2. Set the Main PCB to the computer.
 3. Fix the Main PCB using the six Screws<N9>.
 4. Connect the ten Cables to the corresponding Connectors (CN6, CN7, CN24, CN19, CN28, CN21, CN802, CN18, CN15, CN25).

Screws <N9>: DFHE5025XA

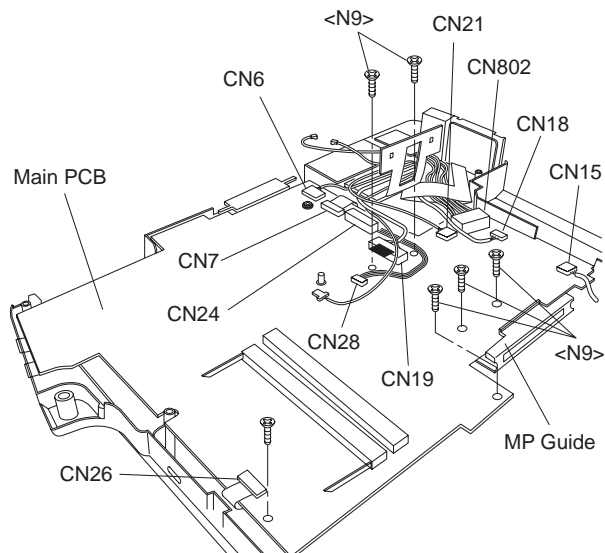

Arranging the Cables to the Cable Holder and their Wiring Order

- Pull the surplus length of the Cable coming from the LCD side to inside of the unit.
(If the surplus length comes outside, it will be caught by the center cover during setting.)
- Fit the Cables to the corresponding grooves of the Cable Holder.
- Ensure the Cables in the Cable Holder are wired in the correct order.

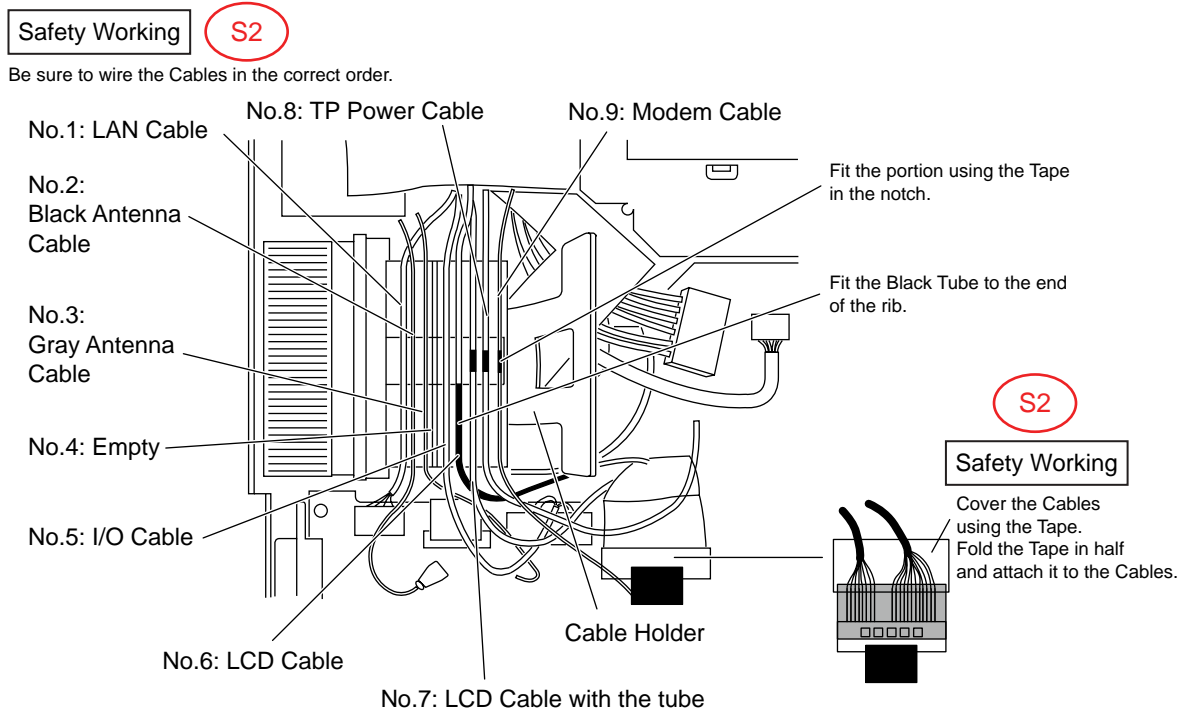

Arranging the FAN Cable

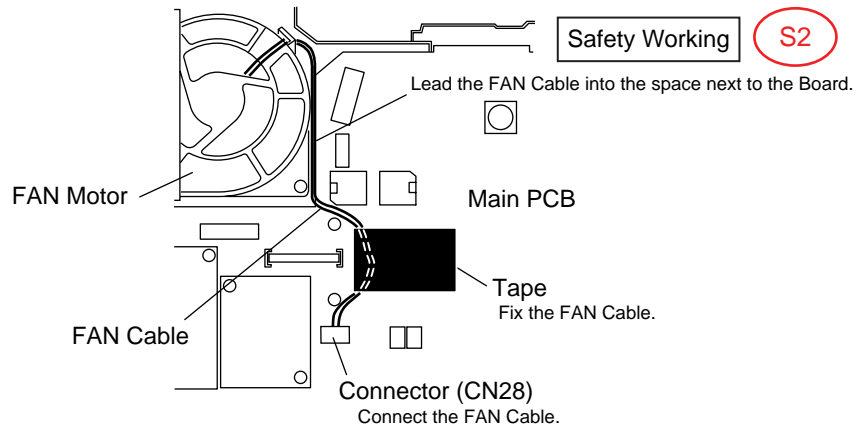

9.2.12. Setting the Wireless Module and MDC Module

1. Connect the Modem Cable to the Connector, and fix the MDC Module to the Main PCB using the two Screws<N9>.
2. Connect the Wireless Module to the Connector of the Main PCB, and fix it using the two Screws<N9>.
3. Connect the two Antenna Cables to the two Connectors on the Wireless Module.
 - Antenna Cable (Black): MAIN Connector
 - Antenna Cable (Gray): AUX Connector

Screws <N9>: DFHE5025XA

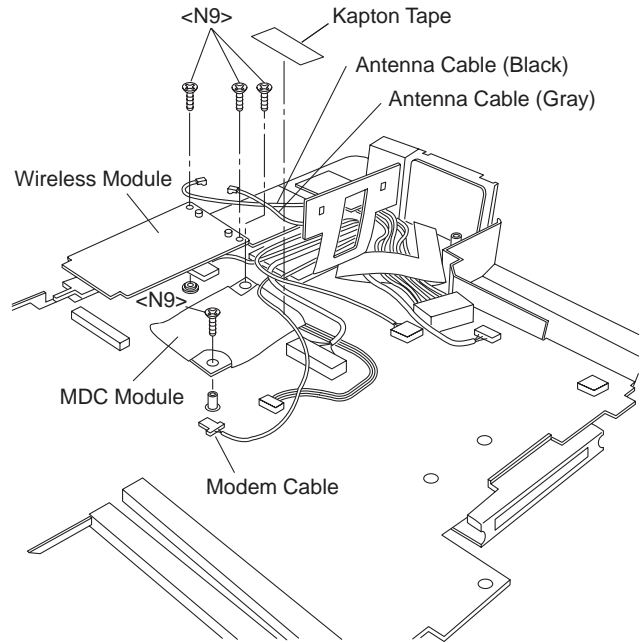

Arranging the Modem Cable

<Preparation for assembly of the MDC Module>

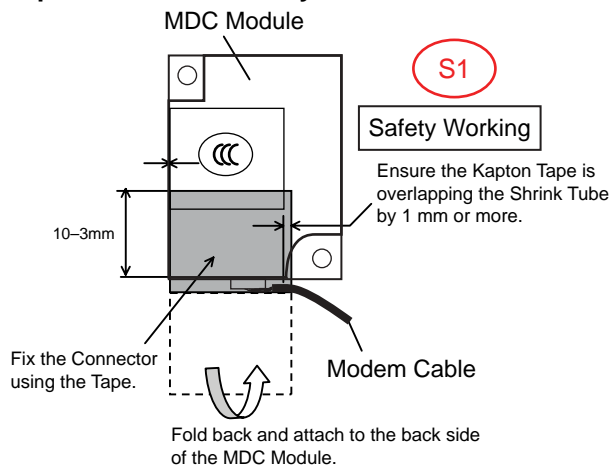

Arranging the Modem Cable

<Good example>

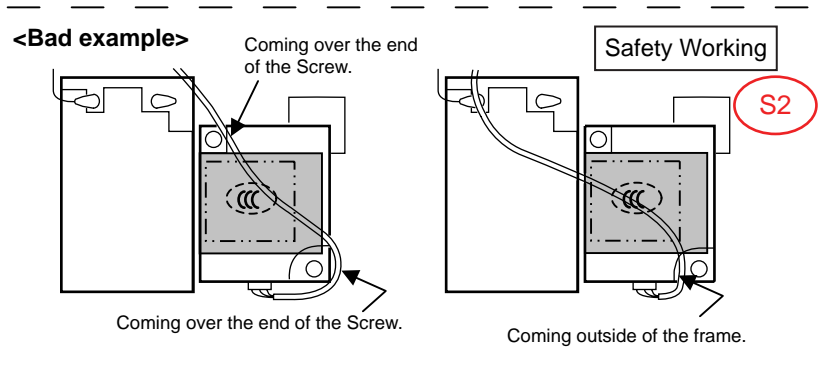
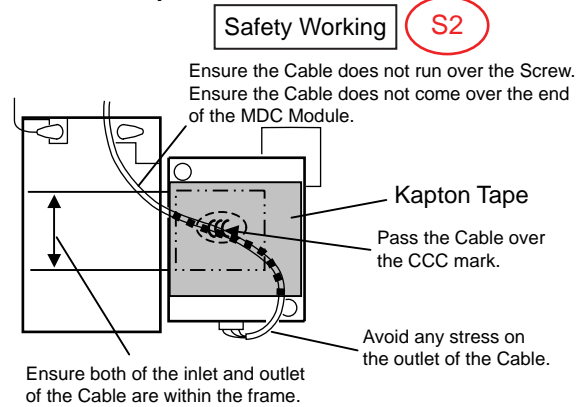

9.2.13. Setting the Bottom Case

1. Attach the Gasket and Sheet.
2. Set the Bottom Case.
3. Fix the Bottom Case using the ten Screws<N7>. No1 to No10
4. Fix the Bottom Case using the six Screws<N5>. No11 to No16
5. Fix the Bottom Case using the two Screws<N8>. No17, No18
6. Close the Lid Covers.

Note:

Tighten the Screws in the numbered order (No1 to No18).

Screws <N5>: DXSB2+6FNL

Screws <N7>: DXYN2+J16FNL

Screws <N8>: DXYN2+J8FNL

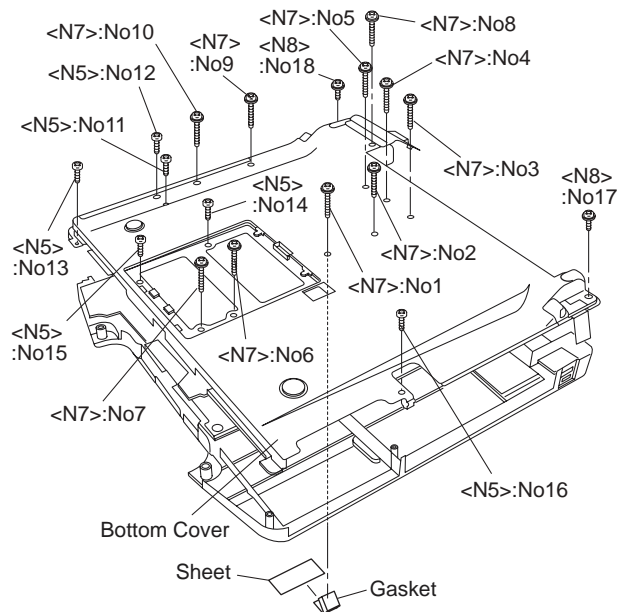

9.2.14. Setting the Handle Ass'y

1. Set the two Sleeves A, the Handle Ass'y and the two Sleeves B.
2. Fix the Handle Cover L and R using the two Screws<N2>. No1, No2
3. Fix the Handle Cover L and R using the three Screws<N4>. No3 to No5

Note:

Tighten the Screws in the numbered order (No1 to No5).

Screws <N2>: DRHM4+10FKS

Screws <N4>: DRSB2+6FKL

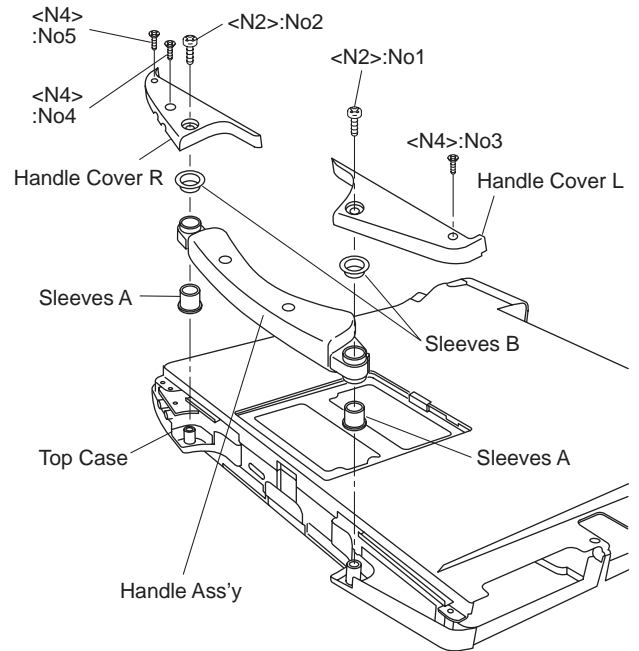

9.2.15. Setting the Speaker and the LED PCB

1. Fix the LED PCB using the two Screws<N9>.
2. Set the Speaker L and R to the computer.
3. Connect the Speaker Cable L and R to the two Connectors (CN1002, CN1003) on the LED PCB.
4. Fix the Speaker Cable L and R using the Tape.
5. Fix the Speaker L and R using the Speaker Holder.
6. Paste the Sheet.

Note:

Ensure the three Hooks of the Speaker Holder are securely set in the computer.

Screws <N9>: DFHE5025XA

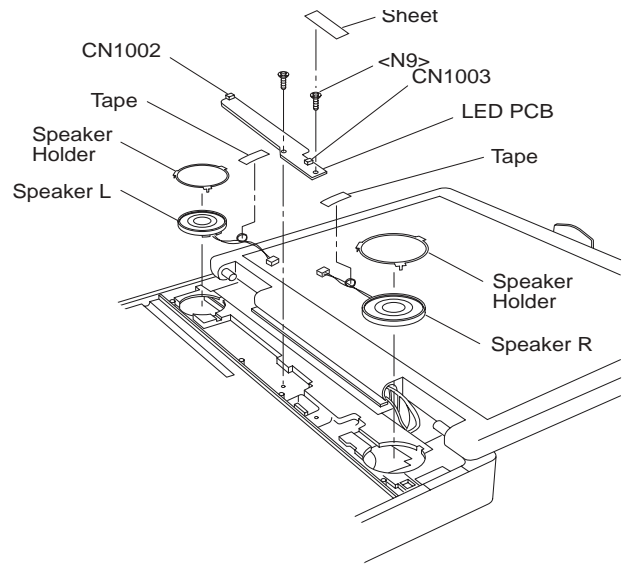

Soldering the Speaker Cable and Setting the Speaker Rubber

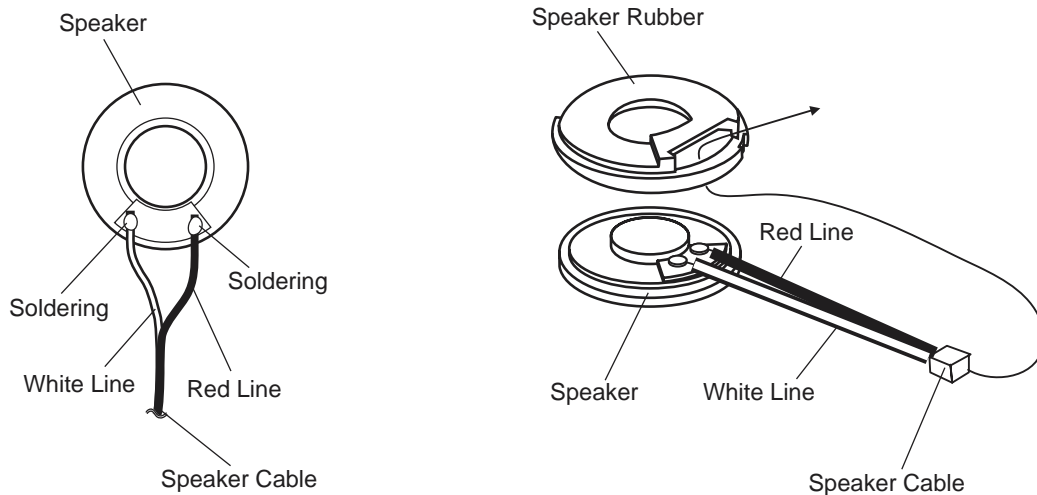

Cautions for Setting the Speaker

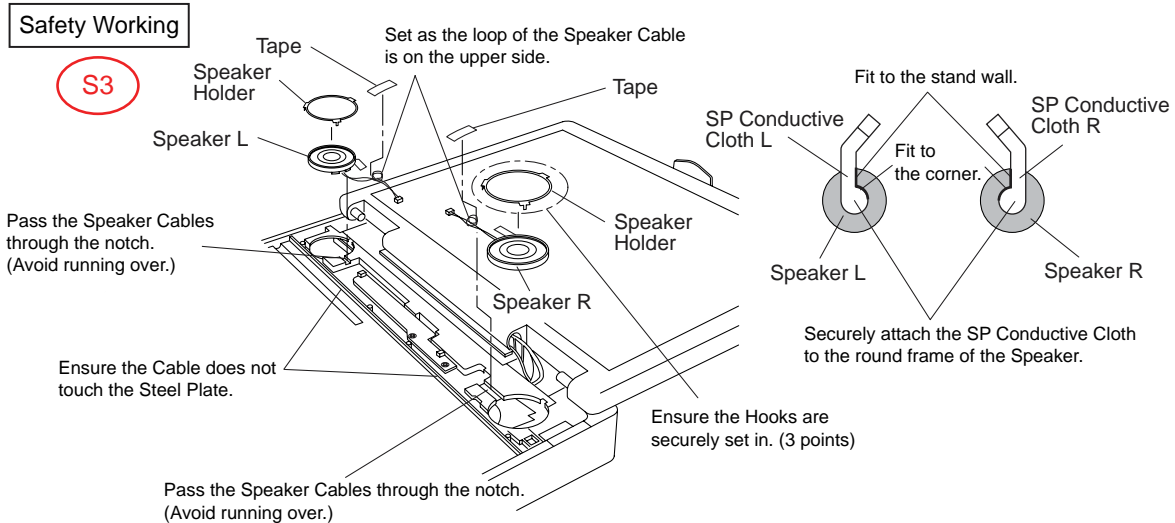

9.2.16. Setting the Keyboard

1. Connect the KBD FPC Cable to the Connector (CN25) of the Main PCB.
2. Connect the two Cables of the Keyboard to the two Connectors on the KBD FPC.
3. Remove the Release Paper of the KBD WP Sheet, and attach the KBD WP Sheet to the computer as it covers the Cable of the Keyboard.

Note:

Press strongly enough until the color of the contact of two-sided tape is changed.

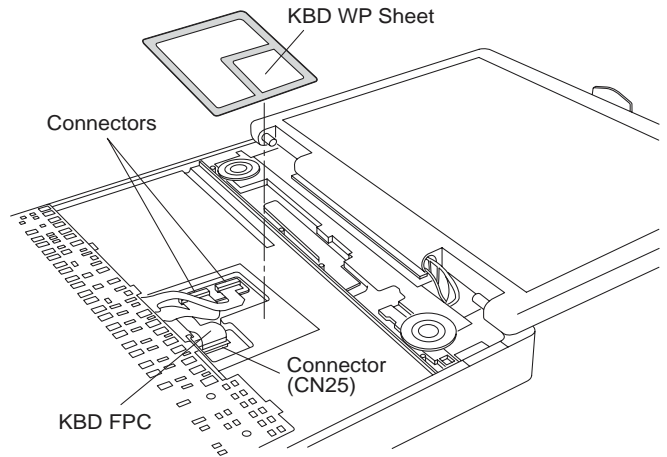

4. Insert the front Hooks of the Keyboard and the FPC to the computer, and set the Keyboard to the computer.
5. Fix the KBD Angle L and R using the four Screws <N9>.
6. Hook the six front Hooks of the Center Cover to the KBD Angle L and R.
7. Hook the seven rear Hooks of the Center Cover to the computer, and press the Center Cover to be securely set in.

Screws <N9>: DFHE5025XA

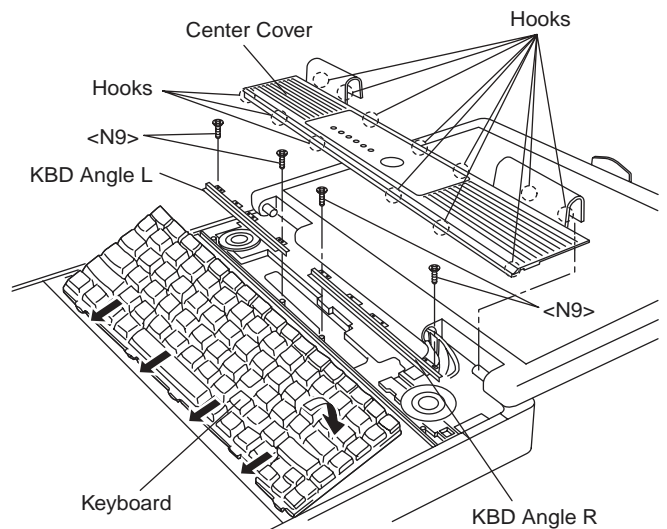

Cautions for Setting the Center Cover

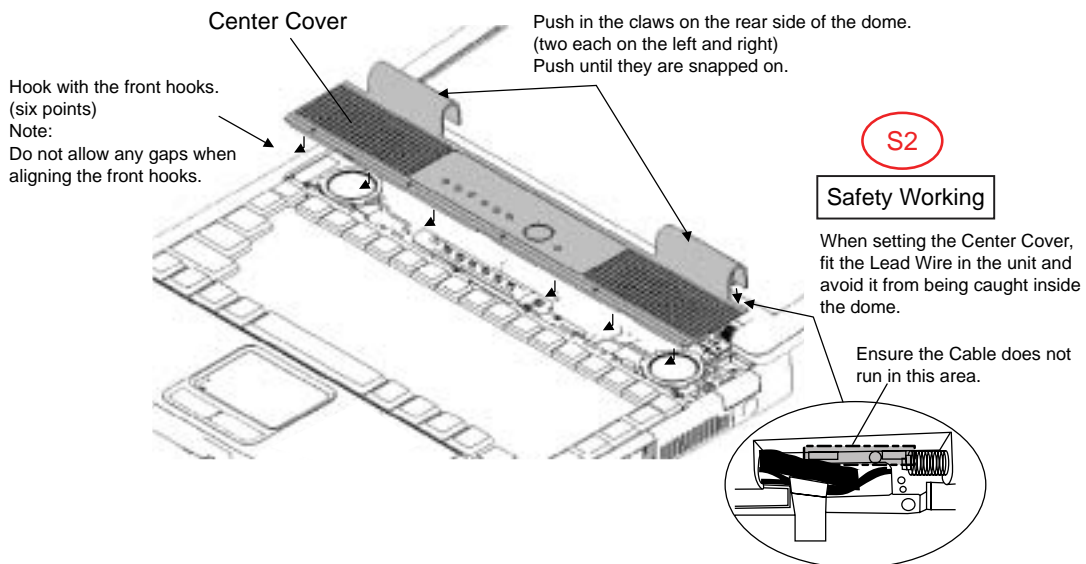

9.2.17. Setting the DIMM Memory Card and DIMM Cover

1. Set the DIMM Memory Card to the Main PCB.
2. Fix the DIMM Cover using the two Screws<N1>.

Screws <N1>: XSB2+3FNL

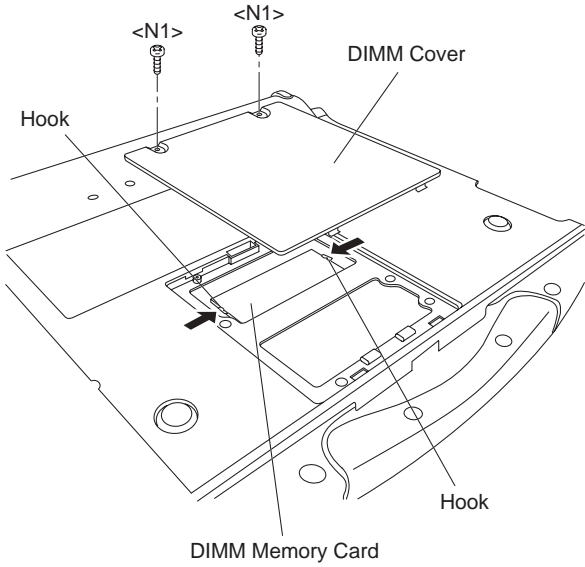

9.2.18. Setting the HDD

1. Attach the HDD Earth Plate and HDD Conductive Sheet.
2. Connect the HDD to the HDD FPC.
3. Attach the HDD Damper.
4. Fix the six Hooks, and attach the HDD Case.

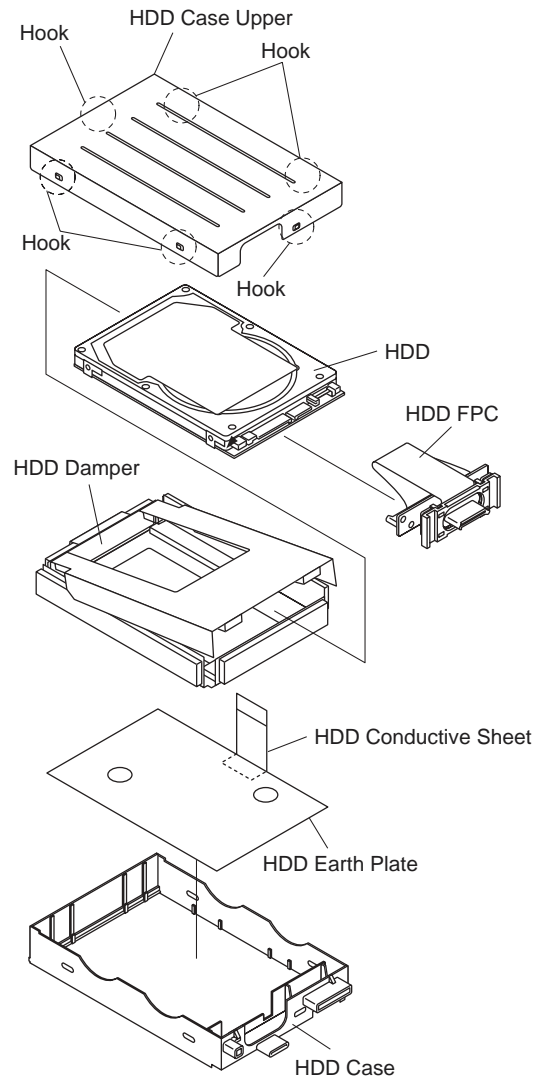

9.2.19. Setting the Battery Pack, the HDD Unit and the DVD-ROM Drive Unit

1. Set the DVD-ROM Driver Unit.
2. Set the HDD Pack.
3. Set the Battery Pack.
4. Slide the Latch 1 to the locked position.

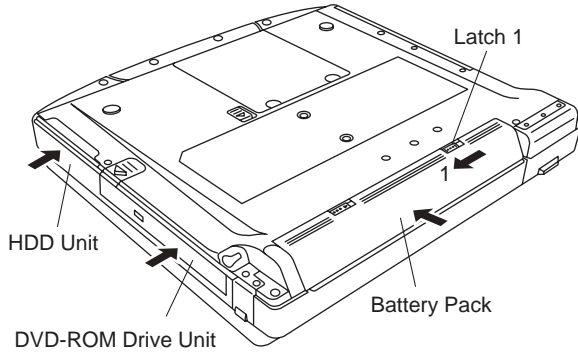

10 Exploded View

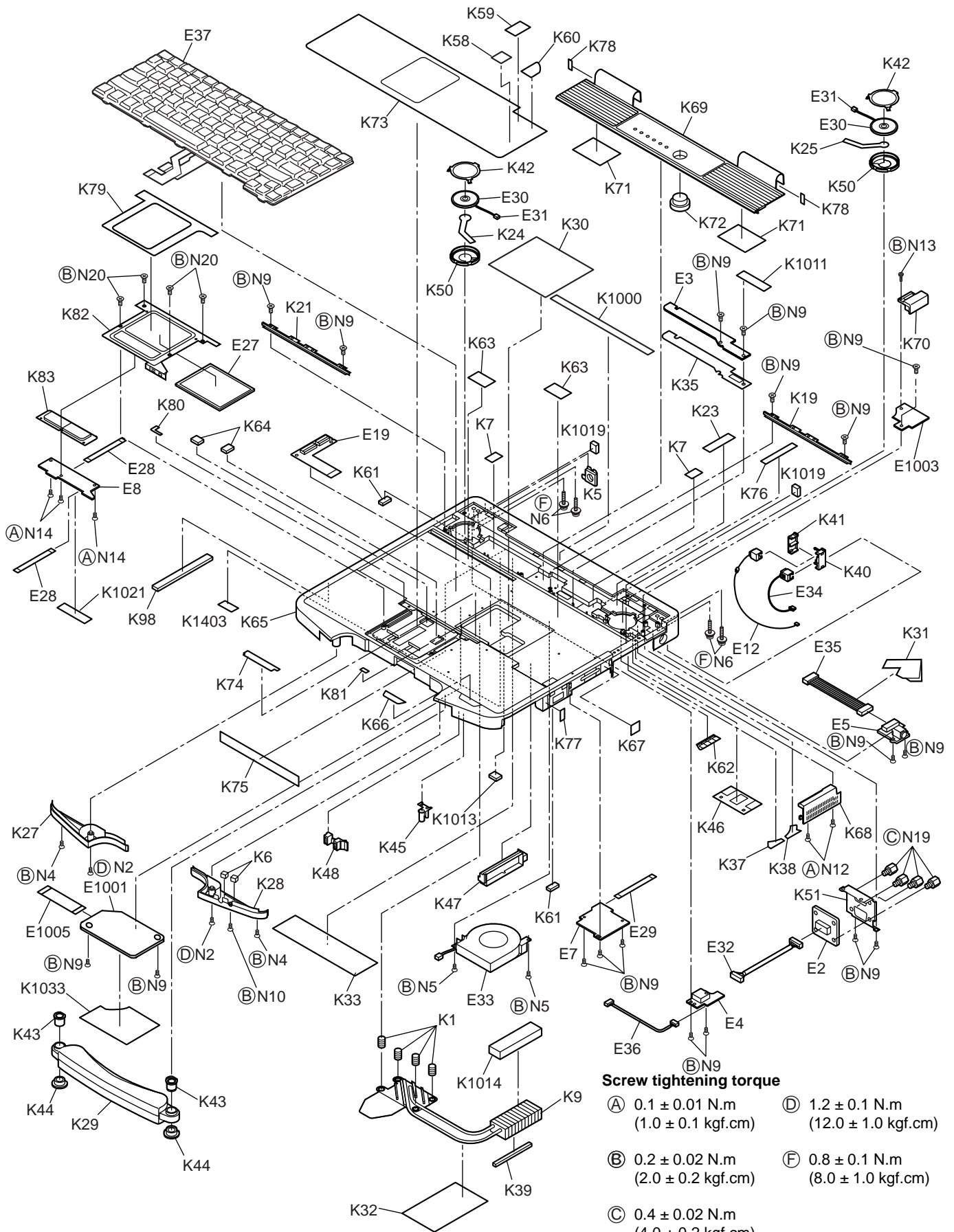

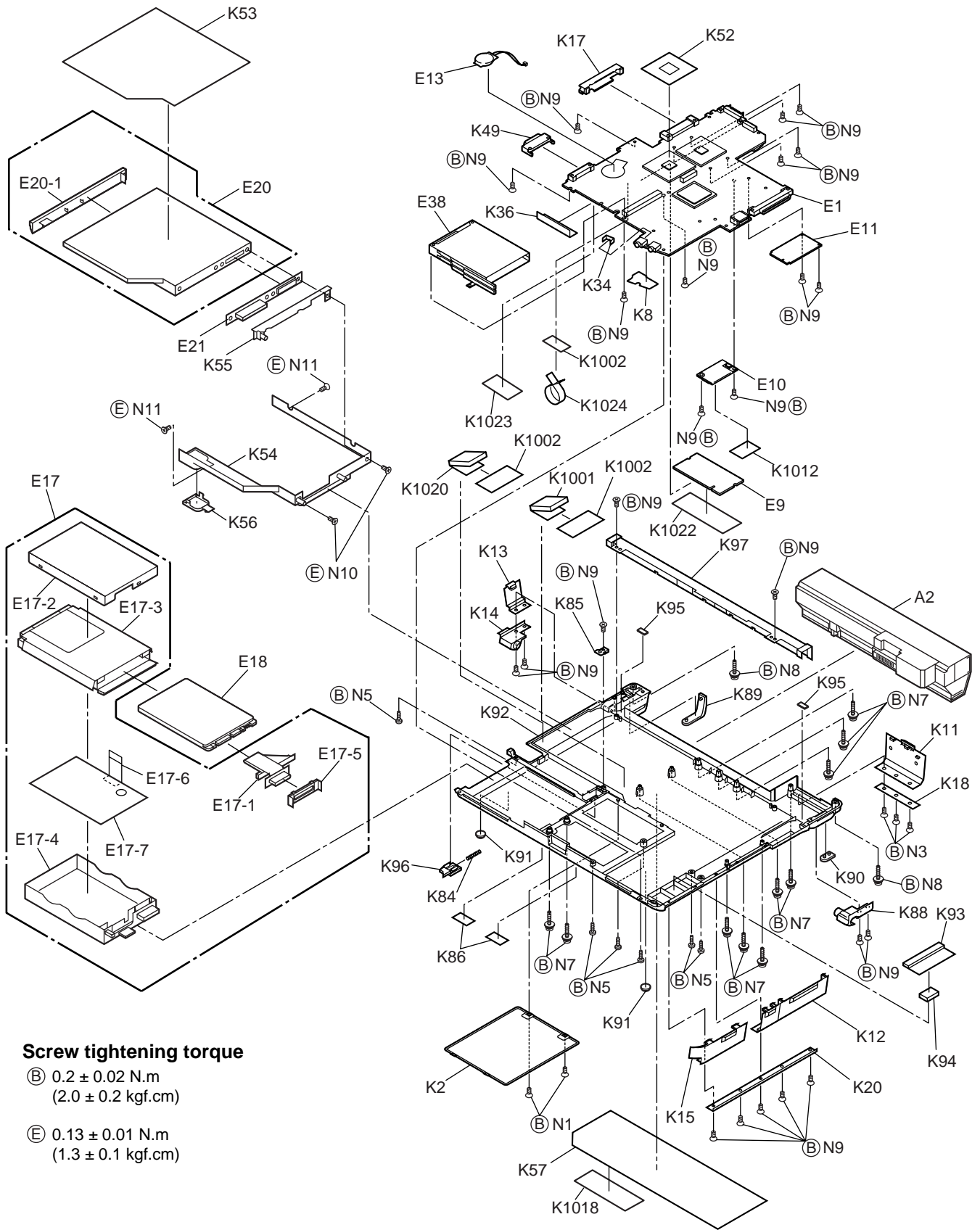

Screw tightening torque

Ⓑ $0.2 \pm 0.02 \text{ N.m}$
 $(2.0 \pm 0.2 \text{ kgf.cm})$

Ⓔ $0.13 \pm 0.01 \text{ N.m}$
 $(1.3 \pm 0.1 \text{ kgf.cm})$

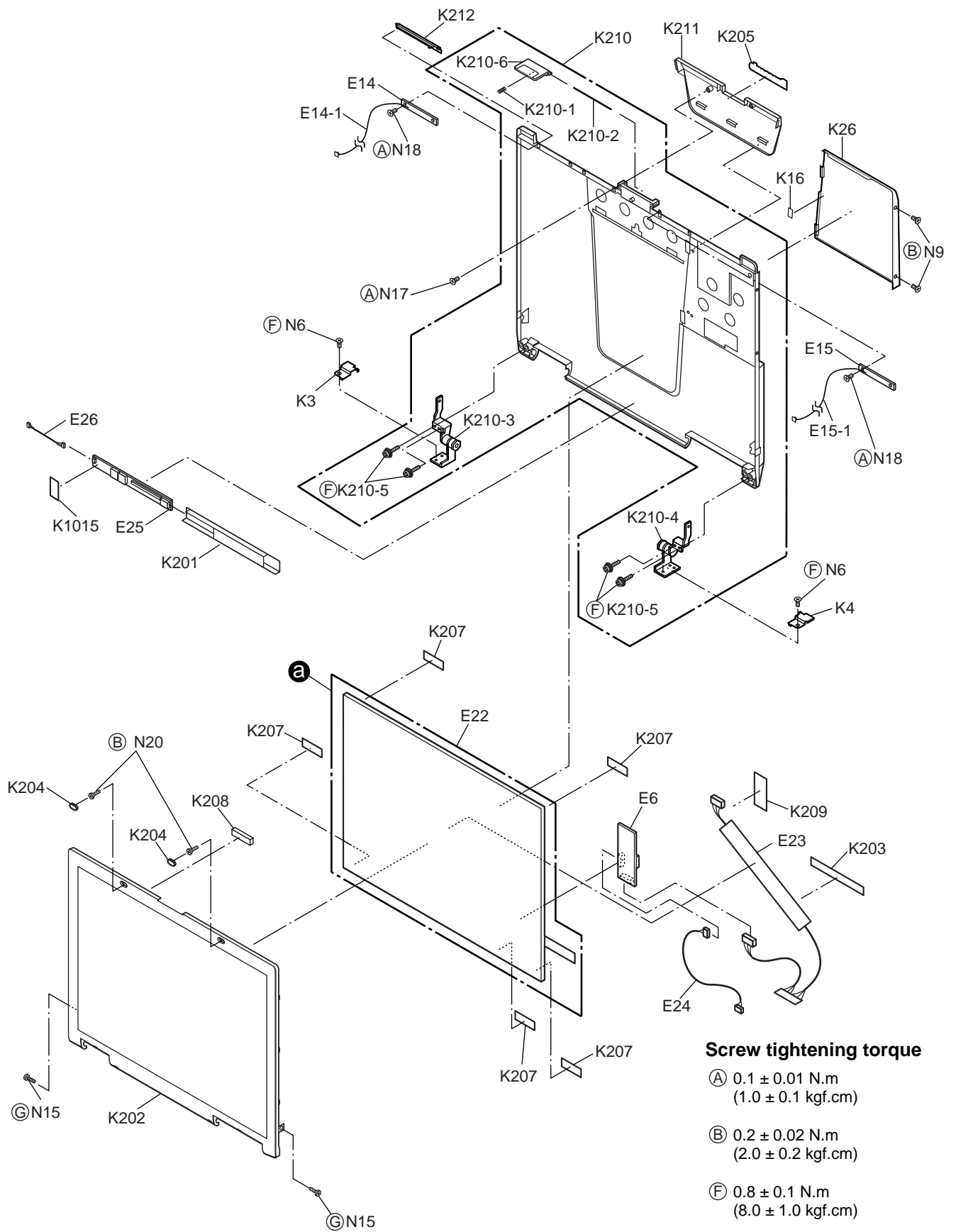

Screw tightening torque

- (A) 0.1 ± 0.01 N.m
(1.0 ± 0.1 kgf.cm)
- (B) 0.2 ± 0.02 N.m
(2.0 ± 0.2 kgf.cm)
- (F) 0.8 ± 0.1 N.m
(8.0 ± 1.0 kgf.cm)
- (C) 0.375 ± 0.025 N.m
(3.75 ± 0.25 kgf.cm)

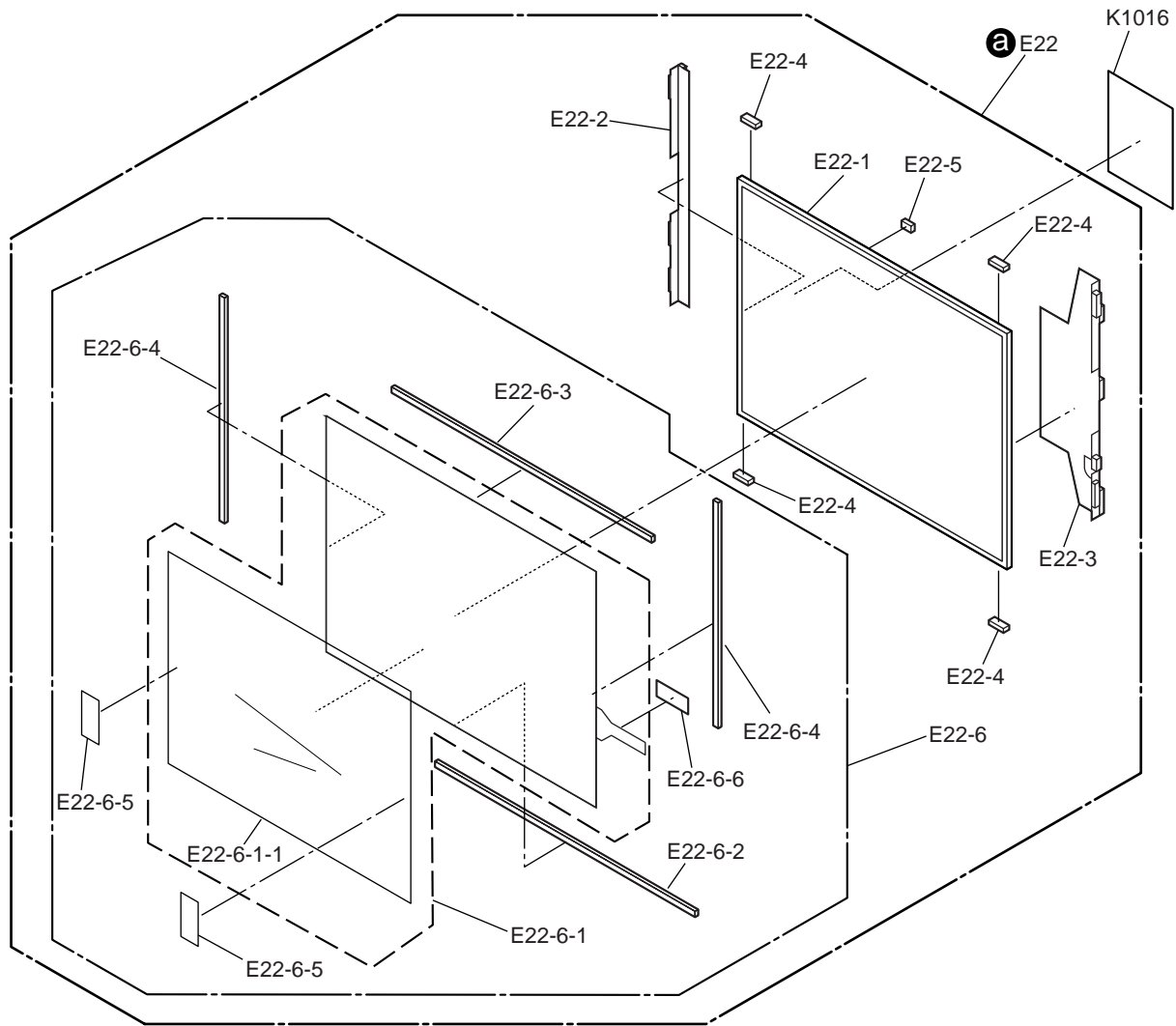







Replacement Parts List

Note : Important Safety Notice

Components identified by  mark have special characteristics important for safety. When replacing any of these components, use only manufacturer's specified parts.

CF-74JCJBDAM

NRP: Non Reusable Parts

REF. NO and AREA	PART NO.	DESCRIPTION	Q'TY
Main Block Unit			
E1	DL3U11660AAA	MK.4 MAIN PCB UNIT (MAIN)	RTL 1
E2	DL3U21660AAA	MK.4 MAIN PCB UNIT (IO)	RTL 1
E3	DL3U31660AAA	MK.4 MAIN PCB UNIT (LED)	RTL 1
E4	DL3U41660AAA	MK.4 MAIN PCB UNIT (USB)	RTL 1
E5	DL3U51660AAA	MK.4 MAIN PCB UNIT (DCIN)	RTL 1
E6	DL3UP1602AAA	PCB, TOUCH SCREEN	RTL 1
E7	DL3U11501AAA	CF74 SUB PCB UNIT(SD)	RTL 1
E8	DL3U21501AAA	CF74 SUB PCB UNIT(PAD SWITCH)	RTL 1
E9	N5ZZ00000162	PC2-4200 SODIMM 512M INFINEON 74MK2	1
E10	 N5HAZ0000016	MODEM	1
E11	 N5HZC0000038	WIRELESS LAN MODULE	1
E12	DFJS996WA	MODEM	1
E13	BR-2330A/SF	LITHIUM COIN BATTERY	NRP 1
E14	DL3UB1514AAA	WLAN ANT PCB UNIT	RTL 1
E14-1	DFJS985ZA	CABLE ANTENNA L (Black)	1
E15	DL3UG1514AAA	WLAN ANT PCB UNIT	RTL 1
E15-1	DFJS817YA	CABLE ANTENNA L (Gray)	1
E17	DFWV99A0130	HDD MOUNTING KIT	1
E17-1	DL3UP1500AAA	CF74 HDD FPC UNIT	1
E17-2	DFHM0383ZA	HDD CASE UPPER	1
E17-3	DFHR3B92YA	HDD DAMPER	1
E17-4	DFHR6200ZB-0	HDD CASE	1
E17-5	DFHR6203ZA	HOLDER HDD CN	1
E17-6	DFHE1027ZA	HDD CONDUCTIVE SHEET B	NRP 1
E17-7	DFMC0872ZA	HDD EARTH PLATE	1
E18	 N3CAYYY00040	HDD (160GB)	1
E19	 DL3UP1499AAA	CF74 KBD FPC UNIT	1
E20	 DFWV78A0253	DVD MULTI DRIVE	1
E20-1	UJSJDYP0420	DVD MULTI DRIVE BEZEL ASSY	1
E21	DL3UP1260BAA	MP DRIVE FPC UNIT	1
E22	DFWV08A0114	LCD UNIT ASS'Y	1
E22-1	DL3DE0179AAA	LCD PREPARATION UNIT	1
E22-2	DFHR3C55ZA	LCD DAMPER A	NRP 1
E22-3	DFHR3H23ZA	LCD DAMPER B	NRP 1
E22-4	DFHR3C57ZA	LCD DAMPER C	NRP 4
E22-5	DFHR3D14ZA	LCD DAMPER D	NRP 1
E22-6	DFWV84A0327	TOUCH SCREEN PANEL KIT	1
E22-6-1	DL3DV0179CAA	TS PREPARATION UNIT	1
E22-6-1-1	DFHR9068ZA	PROTECTIVE FILM	1
E22-6-2	DFHR3243ZA	LCD SHEET A	NRP 1
E22-6-3	DFHR3244ZA	LCD SHEET HDN	NRP 1
E22-6-4	DFHR3245ZA	LCD SHEET SIDE	NRP 2
E22-6-5	DFHR3408ZA	TP SHEET	NRP 2
E22-6-6	DFMX0778ZA	SHEET	NRP 1
E23	DFJS998XA	CABLE LCD + TP	1
E24	DFJS993XA	CABLE TP POWER	1
E25	 N0GF1J000010	INVERTER	NRP 1
E26	DFJS988ZA	CABLE INVERTER	1
E27	N2EAYYY00017	TOUCHPAD	NRP 1
E28	DFJK12T050DB	FFC. PAD	2
E29	DFJK20T040DB	FFC SD	1
E30	LOAA02A00043	SPEAKER	2
E31	DFJS991ZA	CABLE SPEAKER R	2

E32	DFJS997YA	CABLE SERIAL		1
E33	UDQFRPH32	FAN		1
E34	DFJS995XA	LAN		1
E35	DFJS987ZA	CABLE DC IN		1
E36	DFJS992WA	CABLE		1
E37	N2ABZY000035	KEYBOARD VISTA US		1
E38	K1NB94BA0001	PC CARD EJECTOR		1
E1001	DL3UP1690AAA	CF-74MK4 BT PCB UNIT		1
E1003	DL3UP1517AAA	BLUETOOTH ANTENNA UNIT	RTL	1
E1005	DFJK10T053DB	FFC		1
Accessories				
A1	⚠	CF-AA5803AM1	AC ADAPTOR	1
A2	⚠	N4HUNTA00005	LITHIUM ION BATTERY PACK	1
A3	⚠	DFQW5188ZA	MANUAL(CF-74MK4 XP)	1
A4	⚠	K2CG3DR00003	AC CORD	1
A5		DFJS954ZA	MODEM CABLE	1
A6		DFHS9017ZA	TOUCHPANEL CLOTH	1
A7		DFHR6207ZA	PEN	1
A91		DFQM8426MA	RECOVERY DVD	1
Packing Material				
P1		DFPK1249ZA	PACKING CASE	1
P2		DFPK1185ZA	ACCESSORY BOX	1
P3		DFPE0827ZA	HOLDER	1
P4		DFPN0834ZA	CUSHION T	2
P5		DFPN0835ZA	CUSHION B	2
Mechanical Parts				
K1		DFUQ0110ZB	HEAT SINK SPRING	4
K2		DFMD7A65ZA-0	DIMM COVER	1
K3		DFMD7A83ZA	HINGE SCREW COVER L	1
K4		DFMD7A84ZA	HINGE SCREW COVER R	1
K5		DFMD9098ZC	KENGSI TONG PLATE ASSY	1
K6		DFMC0670YA	GASKET	NRP 2
K7		DFMX0778ZA	SHEET	NRP 2
K8		DFMX1223ZA	INSULATION SHEET JACK	NRP 1
K9		DFMY5036YA	HEATSINK	1
K11		DFHG1815XA-0	I/O COVER	1
K12		DFHG1905XA-0	SD USB1 COVER	1
K13		DFHG1819YA-0	USB COVER	1
K14		DFHG1831YA-0	PEN HOOLDER L OUTER	1
K15		DFHG1850ZB-0	COVER 1	1
K16		DFHG1857ZA	ANTENNA COVER CUSHION	NRP 1
K17		DFHG6034ZB	MP GUIDE	1
K18		DFHM0386ZB-0	IO COVER PLATE	1
K19		DFHM0388ZA	KBD ANGLE	1
K20		DFHM0390ZB-0	PC COVER PLATE	1
K21		DFHM0395ZB	KBD ANGLE L	1
K23		DFHE0890ZA	CONDUCTIVE TAPE	NRP 1
K24		DFHE0991ZA	CONDUCTIVE CLOTH SP L	NRP 1
K25		DFHE0992ZA	CONDUCTIVE CLOTH SP R	NRP 1
K26	⚠	DFKE0822XA-0	ANT COVER NO ANT	1
K27	⚠	DFKE0824ZB-0	HANDLE COVER L	1
K28	⚠	DFKE0825ZC-0	HANDLE COVER R	1
K29	⚠	DFKE9082ZA-0	HANDLE ASSY	1
K30		DFHR3C29ZA	KB WATER PROOF A	NRP 1
K31		DFHR3C60ZA	FAN CABLE SHEET	NRP 1
K32		DFHR3C65ZA	SD SHEET	NRP 1
K33		DFHR3C70ZA	MP SLIDE SHEET TOP	NRP 1
K34		DFHR3C91ZB	SHEET LED POWER	NRP 1
K35		DFHR3D05ZA	PWB 5LED SHEET	NRP 1
K36		DFHR3D06ZA	2FFC INSULATION	NRP 1
K37		DFHR3D08ZA	ADHESIVE TAPE FAN1	NRP 1
K38		DFHR3D10ZA	ADHESIVE TAPE FAN2	NRP 1
K39		DFHR3D13ZA	FAN DUCT SHEET	NRP 1

K40		DFHR6204ZA	MODELAN-2		1
K41		DFHR6205ZA	MODELAN		1
K42		DFHR6211ZA	SPEKAER HODLER		2
K43		DFHR6213ZB	SLEEVE A		2
K44		DFHR6214ZB	SLEEVE B		2
K45		DFHR6221ZA	LED LENZ POWER		1
K46		DFHR6234YB	CABLE HOLDER		1
K47		DFHR6235ZA	FAN DUCT		1
K48		DFHR6242ZA	JACK SPACER		1
K49		DFHR9122ZA	HDD GUIDE ASSY		1
K50		DFHG1818ZA-0	SPEAKER RUBBER		2
K51		DFHM0387ZB	IO PLATE		1
K52		DFMX1342ZA	MCH SHEET	NRP	1
K53	⚠	DFGT0944YA	MP SET LABEL		1
K54	⚠	DFKE0709YA-0	MP BOTTOM		1
K55	⚠	DFKE0710ZA-0	MP CABINET TOP		1
K56		DFHR6222ZA-0	MP LATCH		1
K57	⚠	DFGT1247TA	NAME PLATES	NRP	1
K58		DFQT0045ZA	ENERGY STAR LABEL	NRP	1
K59		DFQT0066ZA	VISTA BASIC LABEL	NRP	1
K60		DFQT0075ZA	CENTRINO 2 DUO LABEL	NRP	1
K61		DFMC0855ZA	USB GASKET	NRP	2
K62		DFMC0859ZA	FINGER STICK	NRP	1
K63		DFHE0513ZA	EMI SHEET B	NRP	2
K64		DFHE0790ZA	USB GASKET	NRP	2
K65	⚠	DFKM0497ZC-0	TOP CASE		1
K66		DFGL0145XA-0	INDICATOR SHEET B	NRP	1
K67		DFGL0146YA-0	INDICATOR SHEET SD	NRP	1
K68		DFGX0438ZA-0	FIN COVER		1
K69	⚠	DFGX9023YA-0	CENTER COVER ASS'Y		1
K70		DFGX0434YA-0	BT ANT COVER		1
K71		DFGE0132ZB-0	CENTER COVER NET	NRP	2
K72		DFBC0316ZA-0	POWER SW BUTTON		1
K73		DFHR3B96ZB-0	PALMREST SHEET	NRP	1
K74		DFHR3C30ZA	KB WATER PROOF B	NRP	1
K75		DFHR3C63ZA	MP SLIDE SHEET	NRP	1
K76		DFHR3C98ZA	KBD WP FIN	NRP	1
K77		DFHR3D11ZA	PC CARD SHEET	NRP	1
K78		DFHR3D43ZA	CENTER COVER SPACER	NRP	2
K79		DFHR3D48ZA	PAD WP SHEET A	NRP	1
K80		DFHR3D49ZA	PAD WP SHEET B	NRP	1
K81		DFHR3D50ZA	PAD WP SHEET C	NRP	1
K82		DFGX9024YC-0	PAD BASE ASSY	NRP	1
K83		DFHR3B95YA	PAD BUTTON WP SHEET		1
K84		DFUQ0105ZA	LOCK SPRING HDD		1
K85		DFMD7B44ZB	HDD LOCK SPRING HOLDER		1
K86		DFHE0326XA	DIMM COVER GASKET	NRP	2
K88		DFHG1832YA-0	PEN HOLDER R OUTER		1
K89		DFHG1839ZB-0	LEG LEFT	NRP	1
K90		DFHG1840ZB-0	LEG RIGHT	NRP	1
K91		DFHG370ZA-1	FOOT RUBBER	NRP	2
K92	⚠	DFKF0264ZE-0	BOTTOM CASE		1
K93		DFHR3C64ZC	NO SMART CARD SHEET	NRP	1
K94		DFHR3C99ZA	NO SC CUSHION	NRP	1
K95		DFHR3D15YA	PEN FRICTION SHEET	NRP	2
K96		DFHR6202ZA-0	HDD LATCH KNOB		1
K97		DFHR6209ZB	PEN HOLDER		1
K98		DFHE0997ZA	GASKET	NRP	1
K201		DFMX1284ZA	INVERTER CASE 74	NRP	1
K202	⚠	DFKF0266ZB-0	LCD FRONT		1
K203		DFHR3599ZA	TP/LCD SHEET		1
K204		DFHG1399XA-0	LCD LEG RUBBER	NRP	2
K205		DFHR3C84ZA-0	PANASONIC BADGE	NRP	1

K207		DFHE0277ZA	GASKET	NRP	5
K208		DFHE0418ZA	LID MAGNET	NRP	1
K209		DFHE0465ZA	EMI SHEET 5	NRP	1
K210	⚠	DFKM9035YD-0	LCD REAR ASSY		1
K210-1		DFUQ0095ZA	LCD LATCH SPRING		1
K210-2		DFDF3147ZA	LCD LATCH SHAFT		1
K210-3		DFBH3045YB	HINGE L		1
K210-4		DFBH3046YB	HINGE R		1
K210-5		DXSB3+6FNL	SCREW		4
K210-6	⚠	DFKE0830YA-0	LCD LATCH		1
K211		DFGX0432ZB-0	ANTENNA COVER C		1
K212		DFGX0433ZA-0	ANTENNA COVER L		1
K1000		DFHE1024ZA	GASKET-81TS10-2.5-145	NRP	1
K1001		DFHE1026ZA	GASKET-81TL15-14-10	NRP	1
K1002		DFHR7518ZA	SHEET	NRP	3
K1011		DFHR3G18ZA	BIS HEAD SHEET	NRP	1
K1012		DFMX0709ZA	INSULATION SHEET		1
K1013		DFMY0463ZA	MCH THERMAL RUBBER		1
K1014		DFMY0465ZA	HEAT INSULATING SPONGE	NRP	1
K1015		DFHR3862ZA	TAPE	NRP	1
K1016		DFHR3D73ZA	LCD CABLE SHEET		1
K1018		DFQT0055XA	COA SERIAL LAMINATE	NRP	1
K1019		DFHR3D67ZA	BATT SHEET	NRP	2
K1020		DFMC0888ZA	MP GASKET S	NRP	1
K1021		DFHR3827ZA	PROTECT TAPE	NRP	1
K1022		DFMY3239ZB	DIMM THERMAL SHEET	NRP	1
K1023		DFMX1286ZA	2ND DIMM INSULATION	NRP	1
K1024		DFMY3228ZA	MCH THERMAL PLATE	NRP	1
K1033		DFMX1362ZA	BT MODULE INSULATION SHEET	NRP	1
N1		XSB2+3FNL	SCREW		2
N2		DRHM4+10FKS	SCREW		2
N3		DRHM5025YA T	SCREW		3
N4		DRSB2+6FKL	SCREW		2
N5		DXSB2+6FNL	SCREW		8
N6		DXSB3+6FNL	SCREW		6
N7		DXYN2+J16FNL	SCREW		10
N8		DXYN2+J8FNL	SCREW		2
N9		DFHE5025XA	SCREW		44
N10		DRQT2+E8FKL	SCREW		3
N11		DRHM5067YA	SCREW		2
N12		DXHM0056ZA	SCREW		2
N13		DXQT2+E6FNL	SCREW		1
N14		DRHM0106ZA	SCREW		3
N15		DRHM0075ZA	SCREW	NRP	2
N17		XQN17+BJ5FJK	SCREW		1
N18		XQN17+BJ6FJ	SCREW		2
N19		DFHE5035ZB	SCREW		4
N20		DXQT2+G4FCL	SCREW		6

Replacement Parts List

Note: Important Safety Notice

Components identified by  mark have special characteristics important for safety.

When replacing any of these components use only manufacturer's specified parts.

CF-74JCJBDAM

REF. NO and AREA	PART NO.	DESCRIPTION	Q'TY
MAIN PCB			
C 1, 2, 3, 4, 5, 7, 44, 45, 46, 47, 55, 56, 60, 74, 75, 80, 87, 95, 98, 107, 109, 110, 111, 112, 113, 114, 120, 123, 125, 129, 142, 143, 144, 145, 174, 175, 178, 179, 181, 182, 184, 185, 192, 193, 197, 198, 200, 201, 202, 203, 204, 205, 206, 207, 209, 210, 211, 212, 215, 216, 217, 218, 246, 249, 250, 252, 255, 257, 260, 261, 263, 267, 268, 269, 272, 273, 274, 278, 279, 280, 281, 282, 283, 285, 286, 287, 288, 289, 291, 297, 311, 315, 316, 317, 320, 323, 324, 325, 326, 327, 328, 335, 337, 339, 340, 341, 342, 345, 347, 349, 372, 395, 398, 403, 404, 405, 406, 413, 429, 430, 431, 432, 433, 434, 435, 436, 437, 439, 443, 446, 447, 460, 463, 466, 468, 469, 470, 471, 472, 474, 476, 480, 486, 493, 494, 495, 511, 515, 516, 517, 518, 519, 520, 521, 522, 523, 524, 525, 526, 527, 528, 530, 788, 835, 836, 845, 866, 869	F1G1C104A042	CAPACITOR, 16V, 0.1μF	168
C 6, 52, 79, 88, 89, 100, 180, 199, 753, 770, 779	EEFCX0D221R	CAPACITOR, 2V, 220μF	11
C 8, 121, 130, 135, 136, 166, 167, 168, 169, 170, 171, 172, 173, 176, 177, 243, 244, 352, 353, 354, 355, 356, 363, 375, 384, 385, 386, 388, 389, 390, 393, 399, 408, 427, 428	F1G1A104A014	CAPACITOR, 10V, 0.1μF	35

C 9, 10, 11, 12, 13, 14, 15, 16, 17, 18, 19, 20, 21, 22, 23, 24, 25, 26, 27, 28, 29, 30, 31, 32, 33, 34, 35, 36, 37, 38, 39, 40, 41, 50, 54, 61, 64, 65, 72, 78, 84, 85, 86, 97, 106, 118, 131, 134, 140, 186, 187, 189, 194, 195, 208, 221, 222, 226, 245, 248, 254, 256, 262, 290, 305, 306, 312, 338, 381, 387, 392, 409, 412, 417, 418, 420, 421, 477, 504, 505, 514, 711, 712, 765, 787, 804, 821, 844	F1J0J106A016	CAPACITOR, 6.3V, 10 μ F	88
C 42, 63, 116, 333, 334, 336, 366, 367, 440, 441, 464, 465, 475, 482, 484, 491, 492, 496, 497, 498, 499, 741, 742, 747, 748, 749, 766, 768, 775, 785, 811, 824	F1G1H102A496	CAPACITOR, 50V, 1000pF	32
C 43, 444, 452, 453, 454, 455, 456, 457, 458, 767, 786, 814, 820	F1G1H100A544	CAPACITOR, 50V, 10pF	13
C 48, 66, 68, 69, 70, 76, 90	F1G0J474A001	CAPACITOR, 6.3V, 0.47 μ F	7
C 49, 57, 82, 83, 93, 94, 357, 362	F1G0J224A001	CAPACITOR, 6.3V, 0.22 μ F	8
C 51, 53, 71, 77, 91, 92, 96, 105, 108, 117, 188, 190, 191, 234, 235, 264, 265, 284, 374, 376, 394, 510	F1G0J105A001	CAPACITOR, 6.3V, 1 μ F	22
C 58, 59, 62, 73, 81, 99, 104, 115, 119, 126, 137, 141, 150, 152, 154, 156, 196, 224, 227, 350, 416, 500, 501, 502, 503	F1J0J226A051	CAPACITOR, 6.3V, 22 μ F	25
C 67, 236, 300, 301, 302, 303, 304, 307, 343, 351, 358, 370, 411, 419, 422, 423, 490, 730, 731, 732, 739, 751, 791, 800, 827, 867, 872, 882	F1H1A1050015	CAPACITOR, 10V, 1 μ F	28
C 102, 103	EEFCX0D331R	CAPACITOR, 2V, 330 μ F	2
C 122, 127, 138, 139, 148, 151, 153, 155, 157, 158, 159, 160, 161, 183, 219, 229, 230, 231, 232, 293, 396, 397, 400, 401, 445, 448, 449, 450, 461, 467, 473, 485, 512, 513, 704, 715, 790, 832, 833, 834, 837, 839, 840, 841, 842, 865, 868	F1G1E103A062	CAPACITOR, 25V, 0.01 μ F	47

C 146, 147	F1G1H150A542	CAPACITOR, 50V, 15pF	2
C 149, 377, 378, 379, 380	F1L0J107A016	CAPACITOR, 6.3V, 100µF	5
C 213, 214	F1G1C223A004	CAPACITOR, 16V, 0.022µF	2
C 228	F1G1H7R0A452	CAPACITOR, 50V, 7pF	1
C 233	F1G1H8R0A452	CAPACITOR, 50V, 8pF	1
C 241, 242	F1G1H4R0A543	CAPACITOR, 50V, 4pF	2
C 247, 251, 253, 258, 714	F1G1H471A496	CAPACITOR, 50V, 470pF	5
C 270	F1L3D102A003	CAPACITOR, 2000V, 1000pF	1
C 271, 275, 276, 277	F1H2A103A020	CAPACITOR, 100V, 0.01µF	4
C 292, 294, 438, 462, 757	F1G1H221A496	CAPACITOR, 50V, 220pF	5
C 318, 319, 321, 322	F1J1E105A080	CAPACITOR, 25V, 1µF	4
C 344, 368, 373, 733, 752, 805, 843, 883	F1G1H1010005	CAPACITOR, 50V, 100pF	8
C 365	F1G1H270A542	CAPACITOR, 50V, 27pF	1
C 369, 371	F1H1A225A039	CAPACITOR, 10V, 2.2µF	2
C 382, 383, 391	F1G0J334A001	CAPACITOR, 6.3V, 0.33µF	3
C 410, 531	F1G1C473A004	CAPACITOR, 16V, 0.047µF	2
C 442	EEFUD0J151ER	CAPACITOR, 6.3V, 150µF	1
C 451, 459, 478, 479	F1L1H220A066	CAPACITOR, 50V, 22pF	4
C 481	F1G1A683A014	CAPACITOR, 10V, 0.068µF	1
C 702, 703, 705, 735, 736, 737, 745, 754, 761, 762, 774, 780, 783, 792, 795, 799, 802, 803, 818, 829, 831, 838	F1K1E1060001	CAPACITOR, 25V, 10µF	22
C 706, 707	F1J1E224A081	CAPACITOR, 25V, 0.22µF	2
C 708, 709, 710, 738, 809, 846, 873, 878, 880, 881	F1L1E226A094	CAPACITOR, 25V, 22µF	10
C 713, 722, 723, 724, 729, 740	F1H1H1830001	CAPACITOR, 50V, 0.018µF	6
C 716, 717, 718, 720	EEFSX0D331ER	CAPACITOR, 2V, 330µF	4
C 721, 746	F1G1H222A496	CAPACITOR, 50V, 2200pF	2
C 725	F1G1H390A542	CAPACITOR, 50V, 39pF	1
C 726	F1G1H271A496	CAPACITOR, 50V, 270pF	1
C 727	F1H1H562A748	CAPACITOR, 50V, 5600pF	1
C 728	F1G1H121A495	CAPACITOR, 50V, 120pF	1
C 734	F1G1H181A495	CAPACITOR, 50V, 180pF	1
C 755, 771, 776, 816, 819	F1H1C224A074	CAPACITOR, 16V, 0.22µF	5
C 756	F1G1H391A496	CAPACITOR, 50V, 390pF	1
C 758	F1G1H470A542	CAPACITOR, 50V, 47pF	1
C 759	F1G1H331A496	CAPACITOR, 50V, 330pF	1
C 772, 806, 815, 849, 852, 863, 871, 874, 876, 879	F1H1H104A748	CAPACITOR, 50V, 0.1µF	10
C 773, 796, 801	F1H1H182A748	CAPACITOR, 50V, 1800pF	3
C 777	F1H1H472A748	CAPACITOR, 50V, 4700pF	1
C 789, 794	F2H0D101A003	CAPACITOR, 2V, 100uF	2
C 798, 810, 823	F1H1H103A748	CAPACITOR, 50V, 0.01µF	3
C 807	F1H0J475A010	CAPACITOR, 6.3V, 4.7µF	1
C 808, 813	F1G1H821A496	CAPACITOR, 50V, 820pF	2
C 812	EEFCX0G151R	CAPACITOR, 2V, 150µF	1
C 825, 826	EEFCX0J101R	CAPACITOR, 6.3V, 100µF	2
C 850	F1J1E105A009	CAPACITOR, 25V, 1µF	1
C 875	F1G1H152A496	CAPACITOR, 50V, 1500pF	1

CF 1, 2, 3		D4CC11030026	THERMISTOR	3
CN 2		K1MYL0B00004	CONNECTOR	1
CN 3		K1MYL0B00005	CONNECTOR, DIMM	1
CN 4		K1KA02BA0014	CONNECTOR	1
CN 5		K1MY52BA0190	CONNECTOR	1
CN 6, 21		K1KA08BA0014	CONNECTOR	2
CN 7		K1MN20BA0134	CONNECTOR	1
CN 8		K1NAF0D00003	CONNECTOR	1
CN 12		K1KB12A00099	CONNECTOR	1
CN 13		K1KY42B00001	CONNECTOR	1
CN 14		K1KA62B00003	CONNECTOR	1
CN 15		K1KA06BA0014	CONNECTOR	1
CN 16		K1FY104BA024	CONNECTOR, USB	1
CN 17		K1KY50AA0103	CONNECTOR	1
CN 18		K1KA05BA0014	CONNECTOR	1
CN 19		K1KB40AA0049	CONNECTOR	1
CN 22, 27		K1MN10BA0134	CONNECTOR	2
CN 23		K1FY165EA001	CONNECTOR	1
CN 24		K1KA30BA0060	CONNECTOR	1
CN 25		K1MN30AA0018	CONNECTOR	1
CN 26		K1MN12BA0160	CONNECTOR	1
CN 29		K1KA02BA0085	CONNECTOR	1
CN 801		K1KA10B00213	CONNECTOR	1
CN 802		K1KA06BA0128	CONNECTOR	1
D 1, 3, 4, 8, 29, 30		MA2J72900L	DIODE	6
D 5		MA3J741E0L	DIODE	1
D 9		B0JCMD000014	DIODE	1
D 11		B0JCPD000023	DIODE	1
D 12, 13, 14, 15, 16, 17, 18, 19, 20, 21, 28		B0BD5R6A0005	DIODE	11
D 22		B3AGB0000040	DIODE	1
D 23		B3ADB0000065	DIODE	1
D 24		B3ABB0000210	DIODE	1
D 25, 26, 27		B0KB00000044	DIODE	3
D 31, 722, 723, 724		MA2S111-TX	DIODE	4
D 701, 702		B0JCRD000015	DIODE	2
D 705, 707, 708, 713, 735		B0JCMD000046	DIODE	5
D 706, 712		B0ADCJ000025	DIODE	2
D 710		B0JCCE000008	DIODE	1
D 714, 715, 716, 717, 718, 719, 720		MAZ80620ML	DIODE	7
D 721		B2ABAM000002	DIODE	1
D 725		MAZ81800ML	DIODE	1

D 726		MAZ81200ML	DIODE	1
D 728		B0JDRE000007	DIODE	1
D 729, 730		B0JDBE000002	DIODE	2
D 731, 732, 733, 736		MA3J14700L	DIODE	4
D 734		B0JDSD000025	DIODE	1
F 1, 2, 4, 5, 10, 11, 12	⚠	K5H202Z00005	FUSE, 2A, 32V	7
F 3	⚠	K5H402Z00003	FUSE, 4A, 32V	1
F 6	⚠	K5H502Z00003	FUSE, 5A, 32V	1
F 800, 801, 802	⚠	K5H153A00001	FUSE, 15A, 65V	3
FL 1, 19, 24, 29, 31, 36, 37, 38, 39, 40, 41, 42, 43, 48, 49		F1J0J4750019	CAPACITOR, 6.3V, 4.7µF	15
FL 2, 3, 4, 5, 6, 7, 8, 9, 10, 11, 12, 13, 14, 15, 16, 17, 18, 20, 21, 22, 23, 26, 27, 28, 30, 33, 35, 44, 45, 46, 47, 50, 51, 52, 53		F1H0J1050022	CAPACITOR, 6.3V, 1µF	35
IC 1		C2GBD0000047	CPU	1
IC 2		C1CB00003002	THERMAL SENSOR	1
IC 3		C1CB00003033	LSI	1
IC 4		C0DBGYY00423	LINEAR REGULATOR	1
IC 7		C1CB00003007	LSI	1
IC 9		C0JBAZ002192	IC	1
IC 10		C1CB00003034	LSI	1
IC 11		C1CB00003035	LSI	1
IC 12		C1CB00003013	GIGABIT LAN SWITCH	1
IC 13		C0JBAZ002422	IC, FET SWITCH	1
IC 14		C1CB00002723	CARDBUS CONTOLLER	1
IC 15		C0DBZYY00265	POWER MANAGEMENT SWTICH	1
IC 16, 35		C0DBZYY00271	IC	2
IC 17		C0DBZYY00016	IC	1
IC 19		C1CB00002980	LSI	1
IC 20		C0ZBZ0000978	IC	1
IC 21		C1CB00002790	IC, SECURITY CHIP	1
IC 22, 40, 51		C0JBAA000362	IC, LOGIC	3
IC 23		C3FBNY000187	FLASH ROM	1
IC 25		C0CBCBC00137	IC, REGULATOR	1
IC 26		C2CBYY000639	IC	1
IC 27		C1AB00002507	IC, AUDIO POWER AMPLIFIER	1
IC 28		C0CBCBC00181	IC	1
IC 29		C1CB00002983	LSI	1
IC 30		C0JBAA000511	IC	1
IC 33		C0DBEFE00003	IC	1
IC 37, 50		C0JBAB000624	IC	2
IC 38, 39, 42		C0DBZYY00026	IC, USB POWER SW	3
IC 41, 720		C0JBAE000321	IC, LOGIC	2
IC 43, 709, 717		C0JBAB000621	IC, LOGIC	3
IC 44		C0JBAR000500	IC, SWITCH	1
IC 45		C0JBAA000254	GATE LOGIC	1
IC 46, 47, 49		C0EBE0000459	IC	3
IC 52		C0EBY0000420	VOLTAGE DETECTOR	1
IC 53		C0EBY0000419	VOLTAGE DETECTOR	1
IC 54		C1CB00003000	PCI EXPRESS TO PATA HOST BUS ADAPTER	1
IC 57		C0DBFYY00042	VOLTAGE REGULATOR	1

IC 58, 59, 60		C0JBAA000381	IC, LOGIC	3
IC 701		C0DBAYY00281	DC/DC CONTROLLER FOR CPU	1
IC 702		C0DBAYY00282	DC/DC CONTROLLER FOR GMCH	1
IC 703, 707		C0DBALH00003	IC	2
IC 705		C0DBEFH00002	IC, REGULATOR	1
IC 706		C0DBAYY00423	IC	1
IC 708		C0EBE0000333	IC	1
IC 711		C0JBAD000194	1GATE LOGIC IC	1
IC 714		C0ABBA000093	IC, OP AMP	1
IC 715		C0ABZA000047	IC, AMP	1
IC 716		C0DBDJH00009	IC, LINER	1
IC 718		C0DBFYY00031	IC	1
JK 1, 2		K2HC1YYB0040	AUDIO JACK	2
L 1, 8, 23		G1C1R0MA0289	DC POWER LINE INDUCTOR	3
L 2, 3, 4, 7, 10, 11		J0JHC0000078	DC POWER LINE BEADS	6
L 5, 6		G1C100M00038	INDUCTOR	2
L 12, 19, 20, 21, 22		J0JYC0000098	DC POWER LINE BEADS	5
L 13		G1C100MA0289	DC POWER LINE INDUCTOR	1
L 14, 15, 16, 17, 31		G1C470MA0330	DC POWER LINE INDUCTOR	5
L 24		G1C1R0MA0380	DC POWER LINE INDUCTOR	1
L 25		G1C100MA0380	DC POWER LINE INDUCTOR	1
L 26		J0JJC0000022	DC POWER LINE BEADS	1
L 28		G1C4R7MA0077	INDUCTOR	1
L 29, 39, 40, 41, 42, 43, 48, 56, 57		J0JJC0000021	INDUCTOR	9
L 30		ERJ2GEJ470X	RESISTOR, 1/16W, 470	1
L 32, 33, 34, 35, 36, 37		DDB5Z021D-Y	CHIP BEADS	6
L 38		G1C100Z00013	INDUCTOR	1
L 44, 50, 53, 54, 55, 58, 59, 60, 61, 62		J0MAB0000200	INDUCTOR	10
L 45, 46		J0MAB0000169	INDUCTOR	2
L 47, 51, 52		J0JDC0000105	CHIP BEADS	3
L 63, 64		J0MAB0000203	COMMON MODE FILTER ARRAY	2
L 701, 702		G1CR56ZA0140	INDUCTOR	2
L 703		G1CR82M00006	COIL	1
L 704, 706		G1C2R7Z00003	COIL	2
L 705		G1C2R8MA0240	COIL	1
L 707		G1C100M00030	COIL	1
L 708		G1C4R7MA0240	CHOK COIL	1
L 709, 710		J0JKC0000007	INDUCTOR	2
L 711		G1A160HA0032	COIL	1
PA 1, 2	⚠	D4FB1R100015	PROTECTOR 1.1A	2
Q 1, 2, 3, 36, 37, 51, 52, 61, 712, 714, 717, 724, 725, 753, 785, 794		B1CFGD000023	TRANSISTOR	16
Q 5, 18, 20, 59, 728, 739, 741, 749, 752, 763		B1GDCFNN0031	TRANSISTOR	10
Q 6, 8, 21, 25, 26, 27, 32, 46, 48		B1MBDCA00004	TRANSISTOR	9
Q 7, 15, 49, 58, 711, 738, 740, 748, 751, 761, 764, 765		B1GBCFJN0037	TRANSISTOR	12
Q 9, 23, 24, 776, 781		XP0421300L	TRANSISTOR	5
Q 13		2SB0766ARL	TRANSISTOR	1

Q 14, 19, 35, 47, 50, 713, 723, 727, 729, 730, 731, 732, 733, 734, 735, 762, 777, 778, 780, 782, 783, 796, 797, 798, 799, 800, 801, 802	B1GBCFNN0042	TRANSISTOR	28
Q 22	B1CFNC000004	FET	1
Q 38, 53	B1DHDC000028	TRANSISTOR	2
Q 39, 40, 41, 42, 43, 44, 45	XP0411500L	TRANSISTOR	6
Q 55	XP0450100L	TRANSISTOR	1
Q 60, 745, 750	B1MBFDG00001	FET	3
Q 701, 702	B1CFRD000009	TRANSISTOR	2
Q 703, 704, 705, 706, 747, 757	B1CFRD000025	FET	6
Q 707, 708, 709, 710, 715, 716, 736, 737	B1CFRD000014	FET	8
Q 718, 726	B1MBEDG00001	FET	2
Q 721, 722	B1CFRD000032	FET	2
Q 760, 792	XP0421400L	TRANSISTOR	2
Q 773, 774	B1DHDD000031	TRANSISTOR, FET	2
Q 787, 788, 789, 793	B1CHRD000001	TRANSISTOR	4
Q 795	B1MBEDA00008	TRANSISTOR	1
R 1, 18, 24, 25, 46, 47, 48, 124, 149, 253, 275, 375, 376, 556, 621	ERJ2GEJ102X	RESISTOR, 1/16W, 1KO	15
R 2, 3, 30, 88, 89	ERJ2RKF101X	RESISTOR, 1/16W, 100O	5
R 4, 5	ERJ2RKF27R4X	RESISTOR, 1/16W, 27.4O	2
R 6, 7, 256, 374	ERJ2RKF54R9X	RESISTOR, 1/16W, 54.9O	4
R 8, 28	ERJ2RKF2001X	RESISTOR, 1/16W, 2KO	2
R 9, 29, 66, 68, 70, 718, 754, 771	ERJ2RKF1001X	RESISTOR, 1/16W, 1KO	8
R 11	D1H85104A024	RESISTOR, 1/16W, 51O	1
R 17, 528, 529, 544, 545	ERJ2GEJ510X	RESISTOR, 1/16W, 51O	5
R 19, 269, 286, 413, 530, 531, 532, 781, 782, 794, 795, 829, 834, 836, 841	ERJ2GEJ100X	RESISTOR, 1/16W, 10O	15
R 20, 901, 903, 938, 946	ERJ2GEJ562X	RESISTOR, 1/16W, 5.6KO	5
R 21, 116, 121, 254, 257	ERJ2GEJ560X	RESISTOR, 1/16W, 56O	5
R 22	ERJ2RKF68R0X	RESISTOR, 1/16W, 68O	1
R 31	ERJ2RKF2210X	RESISTOR, 1/16W, 221O	1
R 32, 161, 237, 244	ERJ2RKF24R9X	RESISTOR, 1/16W, 24.9O	4
R 34, 71, 94, 95, 96, 97, 102, 103, 195, 212, 240, 258, 259, 280, 292, 293, 294, 295, 296, 297, 298, 299, 300, 301, 324, 328, 345, 349, 355, 365, 397, 411, 457, 477, 478, 479, 480, 488, 524, 546, 547, 548, 549, 550, 555, 557, 560, 561, 562, 571, 573, 574, 575, 576, 577, 578, 606, 701, 722, 728, 732, 733, 735, 736, 738, 741, 749, 788, 810, 814, 821, 873, 887, 905, 935, 939	ERJ2GE0R00X	RESISTOR, 1/16W, 0O	76

R 35, 36	ERJ2RKF80R6X	RESISTOR, 1/16W, 80.6O	2
R 41	ERJ2RKF2371X	RESISTOR, 1/16W, 2370O	1
R 42	ERJ2RKF49R9X	RESISTOR, 1/16W, 49.9O	1
R 43, 44, 352, 381, 383, 704, 706, 785, 840	ERJ2RKF1002X	RESISTOR, 1/16W, 10KO	9
R 59, 60, 125, 141, 311, 333, 396, 420, 475, 476, 533, 534	ERJ2GEJ330X	RESISTOR, 1/16W, 33O	12
R 61	ERJ2RKF1021X	RESISTOR, 1/16W, 1.02kO	1
R 62, 63, 64, 80, 81, 82	ERJ2RKF75R0X	RESISTOR, 1/16W, 75O	6
R 67, 75	ERJ2RKF4990X	RESISTOR, 1/16W, 499O	2
R 69, 948, 951	ERJ2RHD302X	RESISTOR, 1/16W, 3KO	3
R 74, 207, 233, 285, 426, 500, 517, 522, 551, 568, 770, 857, 858, 859, 860, 861, 862, 863, 932, 936	ERJ2GEJ101X	RESISTOR, 1/16W, 100O	20
R 83, 84, 535, 538	ERJ2GEJ222X	RESISTOR, 1/16W, 2.2KO	4
R 87, 127, 128, 132, 138, 139, 142, 185, 201, 218, 238, 241, 273, 284, 290, 291, 302, 312, 314, 315, 322, 325, 327, 331, 332, 335, 343, 346, 363, 379, 422, 428, 434, 436, 440, 451, 464, 465, 490, 507, 514, 523, 552, 554, 563, 564, 569, 605, 623, 703, 756, 779, 790, 793, 806, 820, 826, 827, 896, 923, 950	ERJ2GEJ103X	RESISTOR, 1/16W, 10KO	61
R 90, 105, 108, 109, 708, 709, 710, 711, 744, 762, 763, 817, 818, 824, 945	ERJ3GEY0R00V	RESISTOR, 1/16W, 0O	15
R 91, 92, 100, 394	ERJ2GEJ1R0X	RESISTOR, 1/16W, 1O	4
R 106, 402, 403	ERJ2GEJ4R7X	RESISTOR, 1/16W, 4.7O	3
R 107	ERJ2GEJ2R2X	RESISTOR, 1/16W, 2.2O	1
R 112, 117	D1H85604A024	RESISTOR, 1/16W, 56O	2
R 113, 114, 115, 118, 119, 120	D1HA56080001	RESISTOR, 1/16W, 56O	6
R 123, 250, 423, 424, 600, 601, 602, 852, 853, 854, 855, 856, 868, 878, 879, 882, 883, 884, 885	ERJ2GEJ105X	RESISTOR, 1/16W, 1MO	19
R 126, 131, 135, 179, 193, 319, 442	D1H81034A024	RESISTOR, 1/16W, 10kO	7
R 129, 130, 214, 215, 469, 470, 471, 472, 473, 474	D1H83304A024	RESISTOR, 1/16W, 33O	10
R 134	ERJ2RKF4750X	RESISTOR, 1/16W, 475O	1
R 155	ERJ2RKF22R6X	RESISTOR, 1/16W, 22.6O	1
R 156, 184, 186, 199, 208, 234, 260, 261, 262, 282, 283, 288, 289, 347, 354, 357, 366, 367, 370, 425, 432, 435, 437, 438, 439, 453, 491, 492, 498, 499, 503, 508, 510, 511, 512, 513, 516, 520, 521, 622, 629, 730, 789, 796, 822, 893, 894, 926	ERJ2GEJ104X	RESISTOR, 1/16W, 100KO	48

R 157		ERJ2GEJ511X	RESISTOR, 1/16W, 510O	1
R 163, 176, 202, 203, 204, 348, 351, 353, 372, 553		D1HY1038A007	RESISTOR, 1/16W, 10kO	10
R 170, 172		ERJ2RKF3241X	RESISTOR, 1/16W, 3240O	2
R 171, 173		ERJ2RKF4530X	RESISTOR, 1/16W, 453O	2
R 175, 181, 182, 321, 341		ERJ2GEJ150X	RESISTOR, 1/16W, 15O	5
R 192, 196		D1H84724A024	RESISTOR, 1/16W, 4.7kO	2
R 198, 342, 344		ERJ2RKF3901X	RESISTOR, 1/16W, 3.9KO	3
R 200		ERJ2GEJ121X	RESISTOR, 1/16W, 120O	1
R 206		ERJ2GEJ334X	RESISTOR, 1/16W, 330KO	1
R 209, 210		ERJ6GEYJ1R0V	RESISTOR, 1/8W, 1O	2
R 232, 303, 390, 441, 515, 729, 847, 866, 898, 904		ERJ2GEJ473X	RESISTOR, 1/16W, 47KO	10
R 239, 243		ERJ2RKF3323X	RESISTOR, 1/16W, 332KO	2
R 248		ERJ2GEJ106X	RESISTOR, 1/16W, 10MO	1
R 251, 252, 398, 399, 407, 408		ERJ2GEJ203X	RESISTOR, 1/16W, 20KO	6
R 255, 807, 808		ERJ2RKF56R0X	RESISTOR, 1/16W, 56O	3
R 271		J0JDC0000105	CHIP BEADS	1
R 272		ERJ2RKF4991X	RESISTOR, 1/16W, 4.99KO	1
R 281		D1H87504A024	RESISTOR, 1/16W, 75O	1
R 318, 371		D1H81044A024	RESISTOR, 1/16W, 100KO	2
R 350, 458, 460, 930		ERJ2RHD103X	RESISTOR, 1/16W, 10KO	4
R 360, 361, 362, 364, 501, 502, 504, 536, 537, 539, 540, 920, 921, 954		ERJ2GEJ472X	RESISTOR, 1/16W, 4.7KO	14
R 373		ERJ2GEJ331X	RESISTOR, 1/16W, 330O	1
R 377, 378, 391, 419, 449		ERJ6GEY0R00V	RESISTOR, 1/10W, 0O	5
R 380, 382, 849, 850		ERJ2RKF5601X	RESISTOR, 1/16W, 5.6KO	4
R 384, 448		D1H84734A024	RESISTOR, 1/16W, 47KO	2
R 385, 427		ERJ2GEJ273X	RESISTOR, 1/16W, 27KO	2
R 386, 388		ERJ2RKF1502X	RESISTOR, 1/16W, 15KO	2
R 387, 389, 813		ERJ2RKF2202X	RESISTOR, 1/16W, 22KO	3
R 392, 393		ERJ2RKF27R0X	RESISTOR, 1/16W, 27O	2
R 395, 414		ERJ2RKF2671X	RESISTOR, 1/16W, 2.67KO	2
R 400, 401		ERJ2GEJ392X	RESISTOR, 1/16W, 3.9KO	2
R 404, 493, 494		ERJ2GEJ471X	RESISTOR, 1/16W, 470O	3
R 405		ERJ2RKF3922X	RESISTOR, 1/16W, 39.2KO	1

R 406, 800, 842	ERJ2RKF2002X	RESISTOR, 1/16W, 20KO	3
R 417	ERJ2GEJ272X	RESISTOR, 1/16W, 2.7KO	1
R 433, 454, 846, 902, 953	ERJ2GEJ474X	RESISTOR, 1/16W, 470KO	5
R 450	D1H81014A024	RESISTOR, 1/16W, 100O	1
R 459	ERJ2RHD303X	RESISTOR, 1/16W, 30KO	1
R 467, 468	ERJ2RKF6041X	RESISTOR, 1/16W, 6.04KO	2
R 495, 496, 497, 558	ERJ2GEJ181X	RESISTOR, 1/16W, 180O	4
R 505, 506	D1H82214A024	RESISTOR, 1/16W, 220O	2
R 518	D1H82204A024	RESISTOR, 1/16W, 22O	1
R 519	D1H81004A024	RESISTOR, 1/16W, 10O	1
R 581	D1HY1048A007	RESISTOR, 1/16W, 100kO	1
R 583	D1BDR100A082	RESISTOR, 1/3W, 0.1O	1
R 598	ERJ2GEJ512X	RESISTOR, 1/16W, 5.1KO	1
R 702, 705	D1JB1M00A001	RESISTOR, 1W, 1mO	2
R 707, 737, 750, 761, 787, 825, 851, 963	ERJ3GEYJ100V	RESISTOR, 1/16W, 10O	8
R 712, 713, 765	ERJ3GEYJ2R2V	RESISTOR, 1/16W, 2.2O	3
R 714, 758	ERJ3GEYJ101V	RESISTOR, 1/16W, 100O	2
R 715, 721, 753, 802	ERJ2RKF1501X	RESISTOR, 1/16W, 1.5KO	4
R 716, 720	ERJ2RKF10R0X	RESISTOR, 1/16W, 10O	2
R 717	ERJ2RKF3011X	RESISTOR, 1/16W, 3.01KO	1
R 719	ERJ2RKF8451X	RESISTOR, 1/16W, 8.45KO	1
R 723	ERJ2RKF1821X	RESISTOR, 1/16W, 1.82KO	1
R 724	ERJ2RKF2000X	RESISTOR, 1/16W, 200O	1
R 725	ERJ2RKF2550X	RESISTOR, 1/16W, 255O	1
R 726	ERJ2RKF2151X	RESISTOR, 1/16W, 2.15KO	1
R 727	ERJ2RKF3093X	RESISTOR, 1/16W, 309KO	1
R 731	ERJ2RKF6811X	RESISTOR, 1/16W, 6.81KO	1
R 734, 766	ERJ2RHD393X	RESISTOR, 1/16W, 39KO	2
R 748, 949	ERJ2RKF1103X	RESISTOR, 1/16W, 110KO	2
R 751, 816	ERJ2RKF1503X	RESISTOR, 1/16W, 150KO	2
R 752	ERJ2RKF6981X	RESISTOR, 1/16W, 6.98KO	1
R 757	D1ZZ00000093	RESISTOR, 1W, 1mO	1
R 767	ERJ3GEYJ104V	RESISTOR, 1/16W, 100KO	1
R 768, 832	ERJ2RKF6201X	RESISTOR, 1/16W, 6.2KO	2
R 772	ERJ2RKF5101X	RESISTOR, 1/16W, 5.1KO	1
R 773, 774, 775, 776, 778, 803, 828, 867	ERJ2GEJ223X	RESISTOR, 1/16W, 22KO	8
R 780, 830	ERJ2GEJ153X	RESISTOR, 1/16W, 15KO	2
R 783, 784, 797, 798, 799, 819, 837, 839, 843, 874	D1BDR022A099	RESISTOR, 1/3W, 0.022O	10

R 786		ERJ2RKF3161X	RESISTOR, 1/16W, 3.16KO	1
R 792, 831, 833, 955		D1BDR033A099	RESISTOR, 1/3W, 0.033O	4
R 801		ERJ2RKF2402X	RESISTOR, 1/16W, 24KO	1
R 804		ERJ2GEJ221X	RESISTOR, 1/16W, 220O	1
R 809, 815, 844		ERJ2RKF1003X	RESISTOR, 1/16W, 100KO	3
R 811		ERJ2RKF8202X	RESISTOR, 1/16W, 82KO	1
R 812		ERJ3GEYJ102V	RESISTOR, 1/10W, 1KO	1
R 835		ERJ2RKF3002X	RESISTOR, 1/16W, 30KO	1
R 838		ERJ2GEJ333X	RESISTOR, 1/16W, 33KO	1
R 845		ERJ2RKF1301X	RESISTOR, 1/16W, 1.3KO	1
R 848		ERJ2RKF1302X	RESISTOR, 1/16W, 13KO	1
R 864, 865		ERJ6GEYJ222V	RESISTOR, 1/10W, 2.2KO	2
R 895		D1BDR470A083	RESISTOR, 1/3W, 0.47O	1
R 897		ERJ2GEJ3R3X	RESISTOR, 1/16W, 3.3O	1
R 899, 919, 922		ERJ2GEJ564X	RESISTOR, 1/16W, 560KO	3
R 928		ERJ2RHD153X	RESISTOR, 1/16W, 15KO	1
R 929, 931		ERJ2RHD104X	RESISTOR, 1/16W, 100KO	2
R 933, 934		ERJ2RKD154X	RESISTOR, 1/16W, 150KO	2
R 937		D1ZZ00000065	RESISTOR, 1W, 4mO	1
R 940, 941, 942, 956, 959, 960		D1BDR082A100	RESISTOR, 1/3W, 0.082O	6
R 943		ERJ2GEJ154X	RESISTOR, 1/16W, 150KO	1
R 944		ERJ2RKF3652X	RESISTOR, 1/16W, 36.5KO	1
R 947		ERA3EEB1692V	RESISTOR, 1/16W, 16.9KO	1
R 958		ERA3EKB1623V	RESISTOR, 1/16W, 162KO	1
T 1, 2		G5BYC0000015	TRANCE	2
X 1		H0J143500079	CRYSTAL OSCILLATOR	1
X 2		H0J327200085		1
X 3		H0J2505A0053	CRYSTAL OSCILLATOR	1
X 4		H2D200500011	CERAMIC CLOCK 20MHZ	1
ZA 1, 2		DRHM0121ZA	SCREW	2
ZA 3, 4		K1YGZZ000060	SPACER	2
IO PCB				
C 1204, 1205, 1206, 1216		F1G1C104A042	CAPACITOR, 16V, 0.1µF	4
C 1207, 1210, 1214		F1G1H5R0A452	CAPACITOR, 50V, 5pF	3
C 1213, 1215		F1L1H220A066	CAPACITOR, 50V, 22pF	2
CN 1201		K1KA30AA0184	CONNECTOR	1
CN 1202		K1FY115A0001	CONNECTOR	1
CN 1203		K1FY109AA004	CONNECTOR	1
FL 1201, 1202, 1203		ERJ3GEYJ100V	RESISTOR, 1/16W, 10O	3
L 1204, 1205, 1206, 1207		ERJ2GEJ270X	RESISTOR, 1/16W, 27O	4
R 1204, 1205		D1H83304A024	RESISTOR, 1/16W, 33O	2
R 1206, 1207, 1208		ERJ3GEY0R00V	RESISTOR, 1/16W, 0O	3

LED PCB				
CN 1001		K1KY50AA0102	CONNECTOR	1
CN 1002, 1003		K1KA02BA0014	CONNECTOR	2
D 1004		B3AGB0000040	DIODE	1
D 1001, 1002, 1003, 1006, 1007		B3ABB0000210	DIODE	5
SW 1001		EVQPLDA15	SWITCH	1
USB PCB				
C 1701		EEFUD0J151ER	CAPACITOR, 6.3V, 150µF	1
CN 1701		K1KA06BA0014	CONNECTOR	1
CN 1702		K1FY104BA024	CONNECTOR, USB	1
L 1701		J0MAB0000200	INDUCTOR	1
L 1702, 1703		J0JHC0000074	INDUCTOR	2
DC-IN PCB				
JK 1501	⚠	K2EEYB000001	JACK	1
CN 1501		K1KA06BA0128	CONNECTOR	1
C 1501		F1H1H104A748	CAPACITOR, 50V, 0.1µF	1
TOUCH SCREEN PCB				
C 1601, 1611, 1614, 1615, 1616		F1G1C104A042	CAPACITOR, 16V, 0.1µF	5
C 1602, 1621, 1622		F1H1A1050015	CAPACITOR, 10V, 1µF	3
C 1603, 1604, 1605, 1606		F1G1E472A062	CAPACITOR, 25V, 4700pF	4
C 1607, 1608, 1609, 1610		F1G1H681A496	CAPACITOR, 50V, 680pF	4
C 1612		F1G1E223A062	CAPACITOR, 25V, 0.022µF	1
C 1613		F1G1H102A496	CAPACITOR, 50V, 1000pF	1
C 1617		F1G0J224A001	CAPACITOR, 6.3V, 0.22µF	1
C 1619		F1L1H220A066	CAPACITOR, 50V, 22pF	1
CN 1600		K1KA15B00072	CONNECTOR	1
CN 1601		K1MN04B00073	CONNECTOR	1
CN 1602		K1KA08BA0014	CONNECTOR	1
CN 1603		K1KA14BA0109	CONNECTOR	1
FL 1600, 1601		F1J0J4750019	CAPACITOR, 6.3V, 4.7µF	2
FL 1602		F1H0J1050022	CAPACITOR, 6.3V, 1µF	1

IC 1600		C0JBAR000500	IC, SWITCH	1
IC 1601		C0EBE0000460	IC	1
IC 1602		C0JBAZ002422	IC, FET SWITCH	1
IC 1603		C1CB00002515	IC, TOUCHPANEL CONTROLLER	1
IC 1604		C0CBCBC00181	IC	1
L 1600		J0MAB0000200	INDUCTOR	1
Q 1600, 1601		B1MBADA00003	TRANSISTOR	2
Q 1602		B1GDCFNN0031	TRANSISTOR	1
Q 1603		B1GBCFJN0037	TRANSISTOR	1
R 1601		ERJ2GEJ273X	RESISTOR, 1/16W, 27KO	1
R 1602, 1603, 1604, 1605, 1614, 1616, 1619, 1621, 1622, 1623, 1624		ERJ2GEJ102X	RESISTOR, 1/16W, 1KO	11
R 1606, 1607, 1608, 1609		ERJ2GEJ822X	RESISTOR, 1/16W, 8.2KO	4
R 1610		ERJ2GEJ103X	RESISTOR, 1/16W, 10KO	1
R 1611, 1617		ERJ2GEJ473X	RESISTOR, 1/16W, 47KO	2
R 1620, 1629		ERJ2GE0R00X	RESISTOR, 1/16W, 0O	2
R 1625		DEARA8AJ473M	RESISTOR ARRAY	1
R 1626, 1627		ERJ2GEJ270X	RESISTOR, 1/16W, 27O	2
R 1628		ERJ2GEJ152X	RESISTOR, 1/16W, 1.5KO	1
X 1600		H2D600400005	OSCILLATOR, 6MHz	1
SD PCB				
C 1401		F1H1A1050015	CAPACITOR, 10V, 1 μ F	1
C 1402		F1G1C104A042	CAPACITOR, 16V, 0.1 μ F	1
CN 1401		K1MN20BA0134	CONNECTOR	1
CN 1402		K1NA09E00073	CONNECTOR	1
D 1401		B3ACB0000020	DIODE	1
Q 1401		B1GDCFJA0025	TRANSISTOR	1
Q 1402		B1GBCFJN0037	TRANSISTOR	1
R 1401		ERJ3GEYJ101V	RESISTOR, 1/16W, 100O	1
R 1402		ERJ2GEJ103X	RESISTOR, 1/16W, 10KO	1
PAD/SWITCH PCB				
C 1301		F1G1E103A062	CAPACITOR, 25V, 0.01 μ F	1
C 1302		F1H0J1050022	CAPACITOR, 6.3V, 1 μ F	1
CN 1301		K1MN12BA0070	CONNECTOR	1
CN 1302		K1MY12BA0105	CONNECTOR	1
R 1301		ERJ2GEJ101X	RESISTOR, 1/16W, 100O	1
SW 1301		K0D112B00071	SW	1
SW 1302		K0ZZ00000618	SW	1
SW 1303, 1304		EVQPLDA15	SWITCH	2

BLUETOOTH PCB				
C 1		F1J0J106A016	CAPACITOR, 6.3V, 10µF	1
C 2, 7		F1G1C104A042	CAPACITOR, 16V, 0.1µF	2
C 3, 5		F1G1H102A496	CAPACITOR, 50V, 1000pF	2
C 6, 9		F1G1E103A062	CAPACITOR, 25V, 0.01µF	2
C 8		F1G1H270A542	CAPACITOR, 50V, 27pF	1
C 10		F1G1HR50A543	CAPACITOR, 50V, 0.5pF	1
CN 1		K1MN10B00147	CONNECTOR	1
IC 1		C0JBAZ002422	IC, FET SWITCH	1
IC 2		N5HZZ0000056	BLUETOOTH MODULE	1
IC 3		C0EBE0000460	IC	1
IC 5		C0JBAC000382	IC, LOGIC	1
JK 1		K1QZA1AE0001	CONNECTOR	1
L 1, 2		J0JJC0000015	INDUCTOR	2
L 4		G1C5N6ZA0029	INDUCTOR	1
L 5		J0MAB0000200	INDUCTOR	1
Q 1		B1GBCFNN0042	TRANSISTOR	1
Q 2		B1DHDC000028	TRANSISTOR	1
R 1, 2, 3		ERJ2GEJ103X	RESISTOR, 1/16W, 10KO	3