

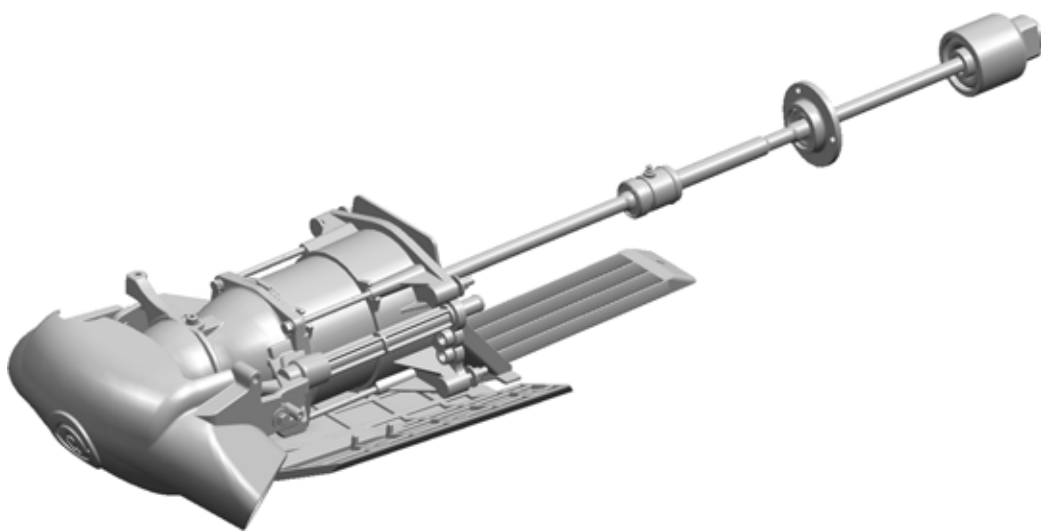

## Jet Propulsion System



This repair manual is valid for the following jet pump variants:

- 403233\_Jet Propulsion System 104 V3 2007 3.1
- 403234\_Jet Propulsion System 104 V4 2007 3.1
- 103820\_Jet Propulsion System 143 V1 2007 3.1
- 403235\_Jet Propulsion System 143 V2 2007 3.1
- 403134\_Jet Propulsion System 66 V1 2008 2.1
- 403238\_Jet Propulsion System 66 V2 2008 2.1



## Table of Contents

1	Before you begin working	1
2	Equipment and Special Tools	1
3	Removing the jet pump from the vehicle	2
3.1	Removing Housing	3
3.2	Removing Rideplate, Grate und Inlet Scoop	4
3.3	Removing Driveshaft	5
3.4	Removing Drive Coupler	7
4	Disassembling the jet pump	8
4.1	Removing Reverse Gate and Steering Nozzle	8
4.2	Removing Water Tube and Pump Wedge	10
4.3	Removing Stator	11
5	Aligning the engine within the vehicle	14
	Terminology	19



## 1 Before you begin working

Disassembly is described in the repair manual. Assembly is carried out in reverse order. Please observe notes following this Symbol →.

The vehicle manufacturer's service manual may be needed as a supplement to this repair manual.



### WARNING

Rotating parts on the driveshaft and the impeller can cause serious lacerations.

Before beginning work of any kind on the jet pump, remove ignition key and lanyard and detach cable on battery from negative terminal.

## 2 Equipment and Special Tools



- Mounting Tool Impeller. See spare parts catalogue. Chapter: Disassembling the jet pump, Stator.
- Alignment Laser Tool Case. See spare parts catalogue. Only in conjunction with an Weber Automotive GmbH engine. Chapter: Aligning the engine within the vehicle.



- Marine grease. Lubricating grease appropriate for Marine use.  
The Weber Automotive GmbH recommends a premium multipurpose lubricating grease. Resistant to freshwater and saltwater. Sustained operating temperature: -60 °C [-80 °F] to +200 °C [+400 °F]. Dropping point > 250 °C [500 °F].
- Sealing agent appropriate for Marine use  
The Weber Automotive GmbH recommends a one-component polyurethane sealant suitable for producing elastic and vibration-proof sealed joints. Resistant to freshwater and saltwater. Temporarily resistant to fuel and petroleum. Sustained operating temperature: -40 °C [-40 °F] to +90 °C [+195 °F]
- Loctite 272 for securing and sealing the screw coupling. Chapter: Reverse gate and steering nozzle.
- Loctite 243 for securing and sealing the screw coupling.



### 3 Removing the jet pump from the vehicle



#### WARNING

Rotating parts on the driveshaft and the impeller can cause serious lacerations.

Before beginning work of any kind on the jet pump, remove ignition key and lanyard and detach cable on battery from negative terminal.

- 1) Remove cable for the steering nozzle (1) and the reverse gate (2).

See the vehicle manufacturer's service manual.

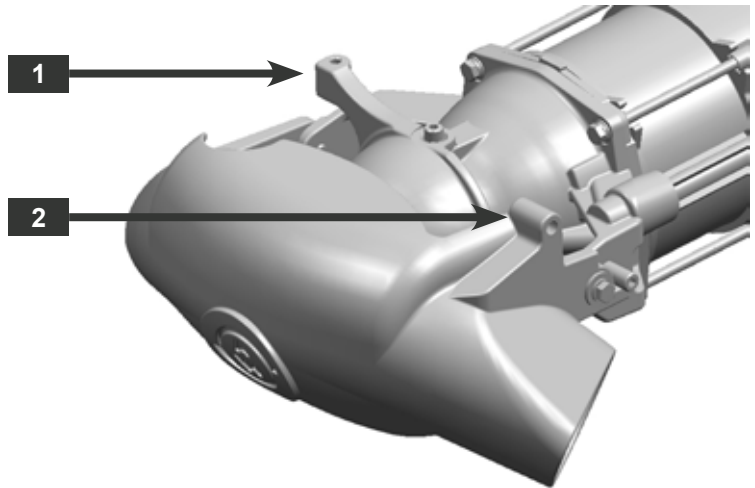

- 2) Remove 5/16 - 18 UNC - 2B bolts (3).

- ➔ Tightening torque:  
20 Nm ± 10 % [14 ft. lb.]
- ➔ Use thread lock Loctite 243.

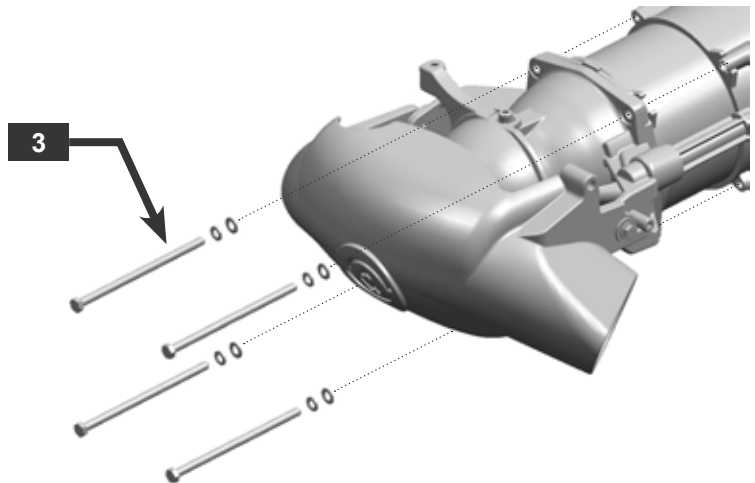



## Removing the jet pump from the vehicle (continuation)



### WARNING

The freely rotating impeller can jam or sever fingers.

Never hold the jet pump on the impeller or reach in.

- 3) Remove seawater cooling tube.  
Remove jet pump (4) from housing.

→ Lubricate surface (5) with marine grease.

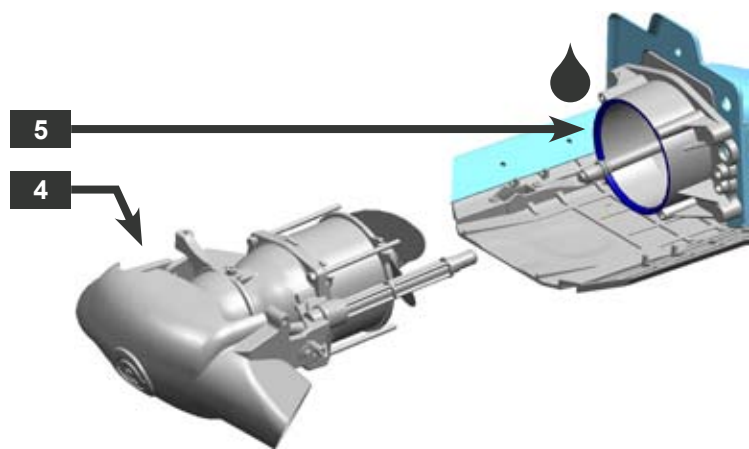

### 3.1 Removing Housing

- 1) Loosen the nuts (1) inside the vehicle and remove the housing. Remove ride plate beforehand if necessary.

→ Replace nuts.  
→ Apply sealing agent (2) as shown and attach housing.  
→ See vehicle manufacturer's service manual for additional information.

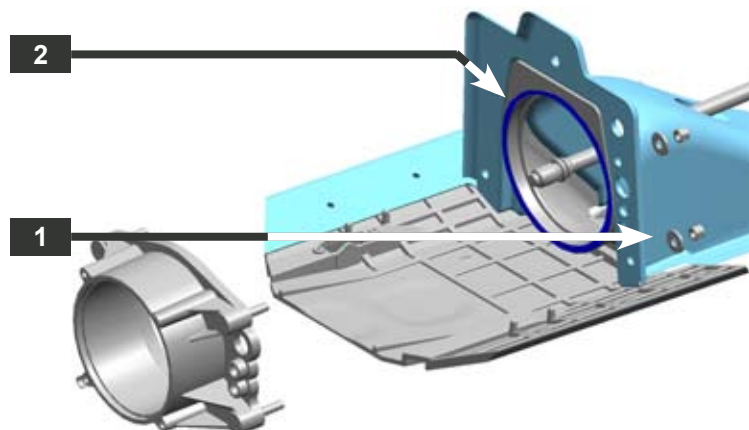

When applying sealing agent, ensure that it stays away from screw threads, water connections, or water hoses. Sealing agent residue can lead to blockages in the water system.



### 3.2 Removing Rideplate, Grate and Inlet Scoop

- 1) Remove rideplate (1).
- 2) Remove grate (2).
- 3) Remove inlet scoop (3).

- ➔ Apply sealing agent (4) as shown and attach ride plate, grate, and inlet scoop.
- ➔ See also vehicle manufacturer's service manual.

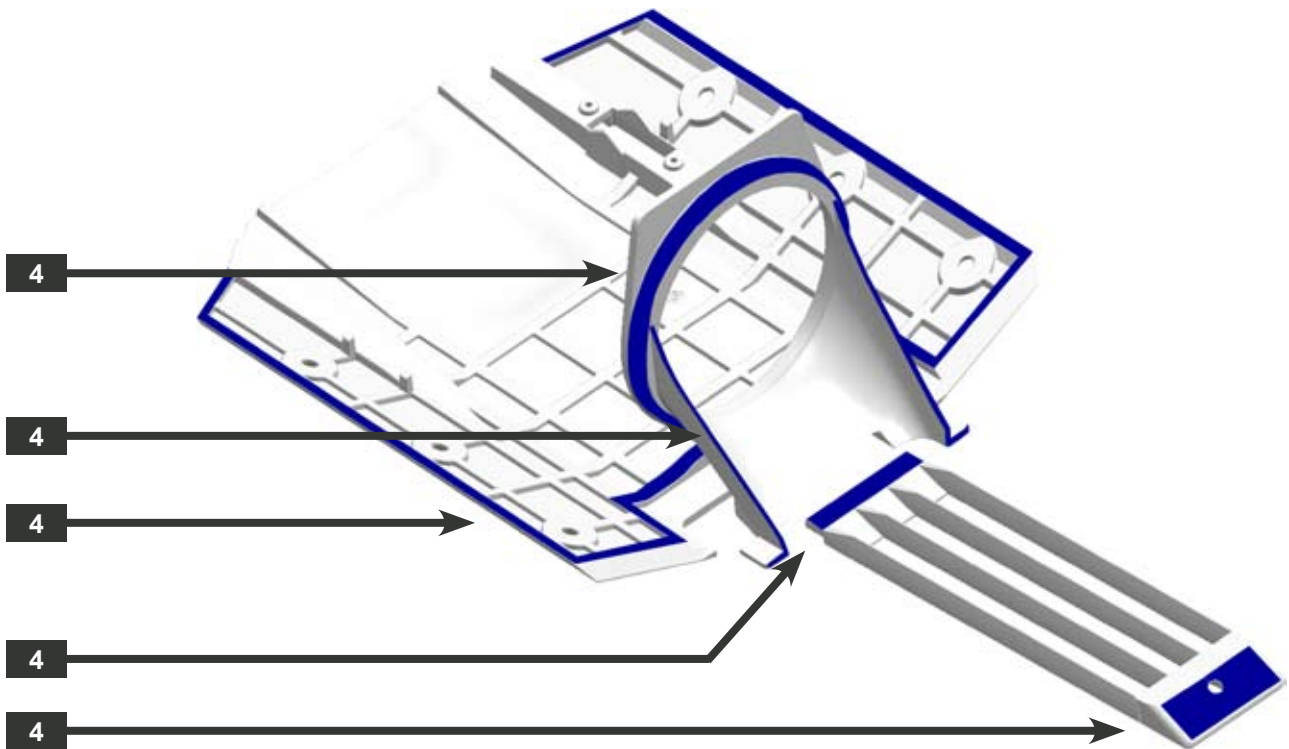
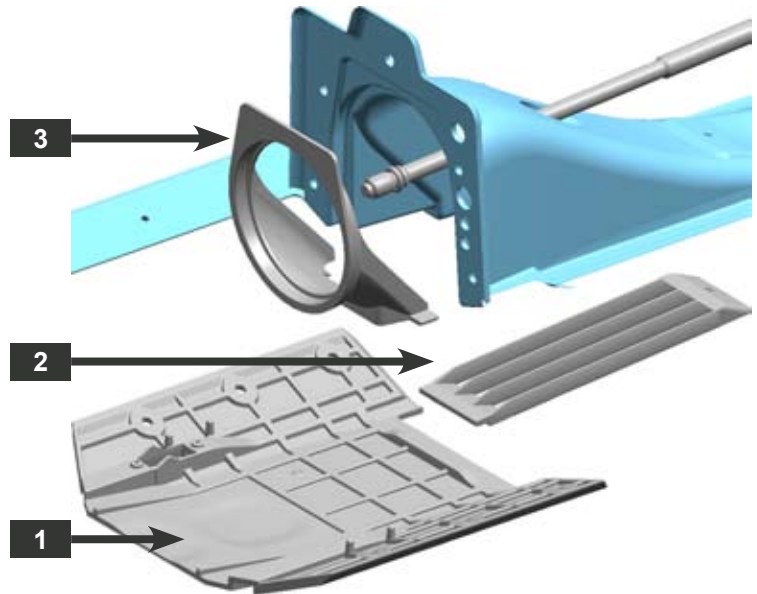

Apply sealing agent carefully to prevent an air gap. The jet pump could take in supplementary air, which would lead to power losses.

### 3.3 Removing Driveshaft

- 1) Remove driveshaft (1) from drive coupling (2). Carefully disassemble seal (3) to avoid damaging the seal.

- ➔ Mount seal (3) and damping bearing (4) with marine grease.
- ➔ Fill seal with marine grease via the lubricating nipple (5) with an grease gun.
- ➔ Assemble the damping bearing (4). See the vehicle manufacturer's service manual.

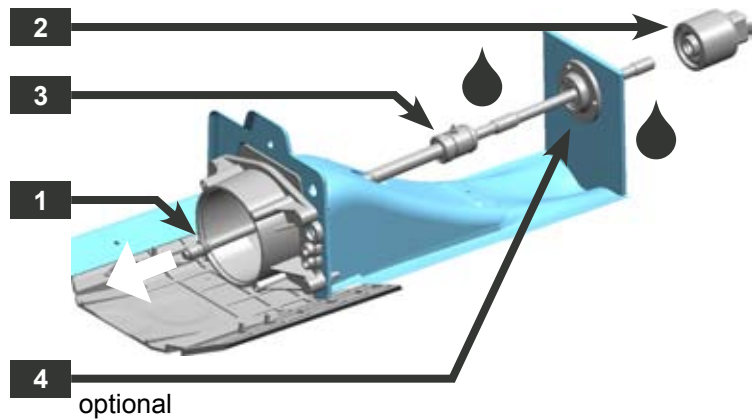

- 2) If the seals of the seal rings (6) were damaged when disassembling the seal, the seal rings must be replaced.

- ➔ Mount seal rings and sleeve with marine grease.
- ➔ Observe the orientation of the seal rings.

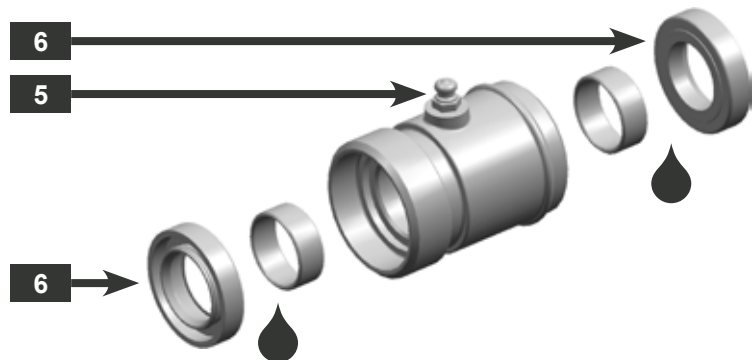

- ➔ Replace O-ring (7).
- ➔ Mount O-ring and both buffers (8) with marine grease.

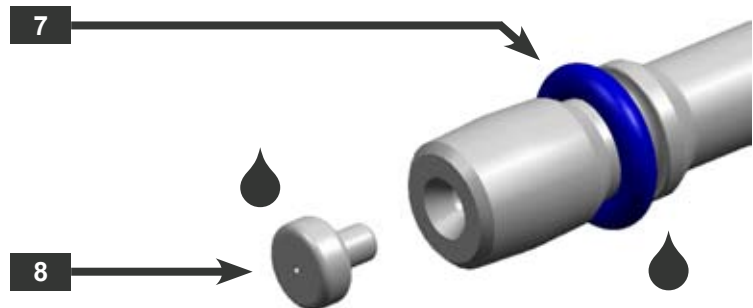

Before installing driveshaft, always check to make sure both bumpers are installed. Missing bumpers lead to an unacceptably large axial clearance and can cause damage, for example, to the driveshaft or the drive coupler.



## Checking Driveshaft

Rotation:

- 1) Lay the cleaned driveshaft on two V-blocks (1). Rotate the driveshaft and measure at point (2) with a dial gauge.

**Maximum acceptable deviation:**

**0,13 mm [0.005 in.]**

- 2) The driveshaft must be replaced if the deviation is greater than the maximum acceptable deviation.

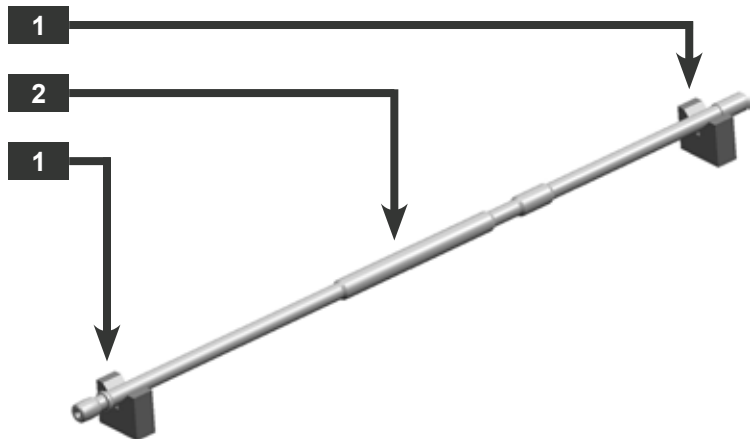

Axial clearance:

- 1) Check the axial clearance in the vehicle with mounted engine, jet pump, seal and damping bearing.

Move the driveshaft in the indicated direction back and forth.

**Required axial clearance:**

**Minimum 4 mm [0.16 in.]**

**Maximum 7 mm [0.28 in.]**

- 2) If the axial clearance is outside the required axial clearance the engine must be accordingly aligned.

See chapter aligning the engine within the vehicle.

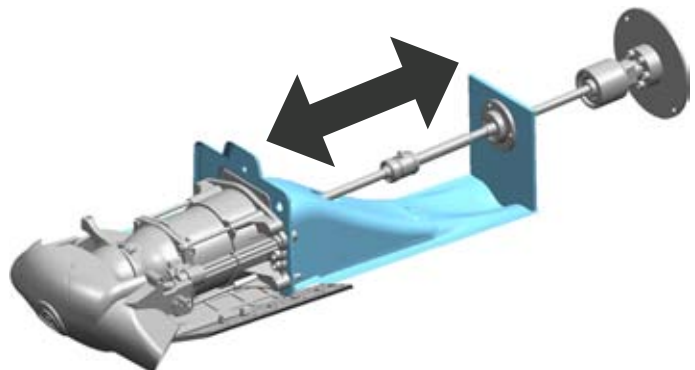

Too little axial clearance causes severe damage to engine and / or jetpump.





### 3.4 Removing Drive Coupler

- 1) Secure the flywheel (1) on the marked points and unscrew the drive coupler (2).

- ➔ Hand-screw the drive coupler sturdily onto the stub shaft (3).
- ➔ Right-hand thread.

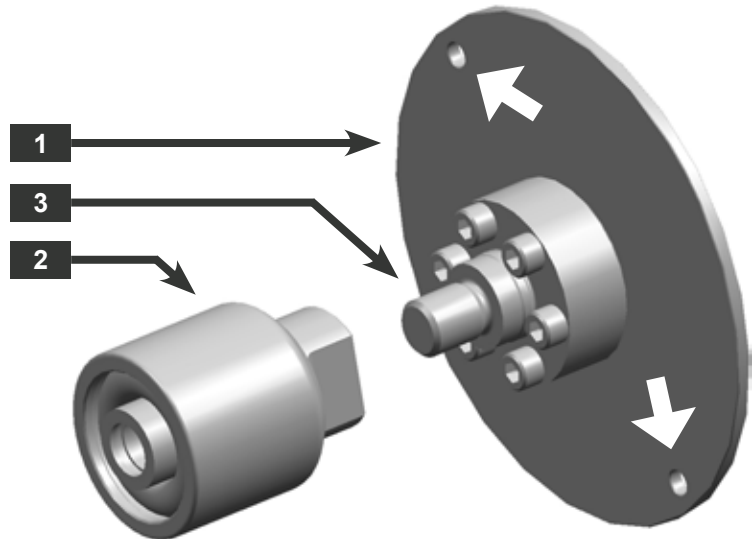

When mounting, the drive coupling is screwed onto the coupling element only hand-tight. When driving, the drive coupling will tighten itself.



## 4 Disassembling the jet pump



### WARNING

The freely rotating impeller can jam or sever fingers.

Never hold the jet pump on the impeller or reach in.

After removal from the vehicle, the jet pump separates into the following components:

- (1) Reverse gate and steering nozzle
- (2) Pump wedge
- (3) Stator
- (4) Water tube
- (5) Housing

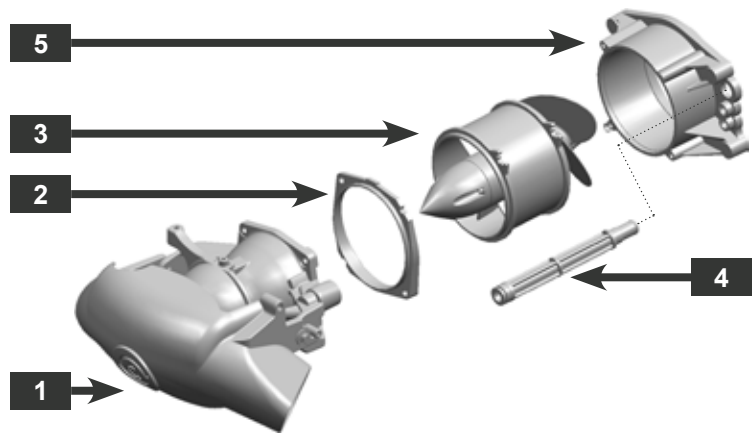

### 4.1 Removing Reverse Gate and Steering Nozzle

- 1) Remove M8 bolts (1) on both sides.

- ➔ Tightening torque:  
20 Nm ± 10 % [14 ft. lb.]
- ➔ Use thread lock Loctite 272

- 2) Remove (2) reverse gate.
- 3) Remove M8 bolts (3) for stopper.

- ➔ Tightening torque:  
20 Nm ± 10 % [14 ft. lb.]
- ➔ Use thread lock Loctite 243.

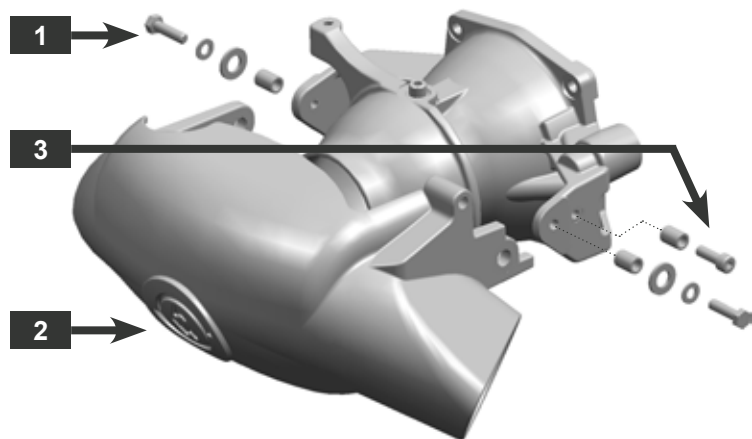



### Removing Reverse Gate and Steering Nozzle (continuation)

- 4) Remove M8 bolts (4).

- ➔ Tightening torque:  
20 Nm ± 10 % [14 ft. lb.]
- ➔ Use thread lock Loctite 243.

- 5) Remove steering nozzle (5).

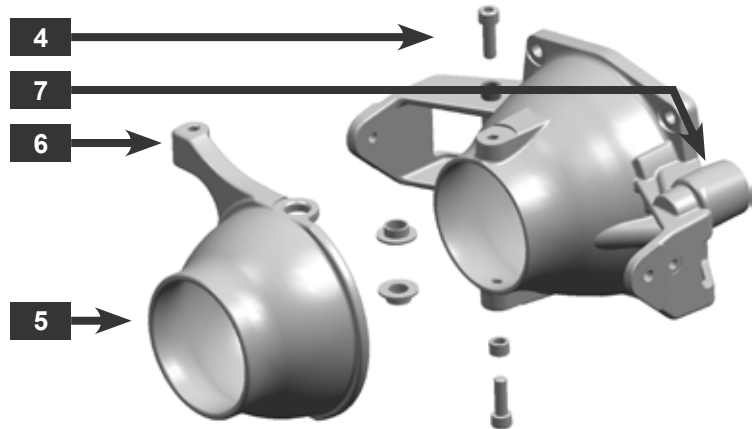

- 6) When removing the screen, the screen receiver in the jet nozzle must not be damaged.

- ➔ Apply sealing agent (8) as shown and attach screen. Observe orientation.
- The openings in the screen must be free and clean.

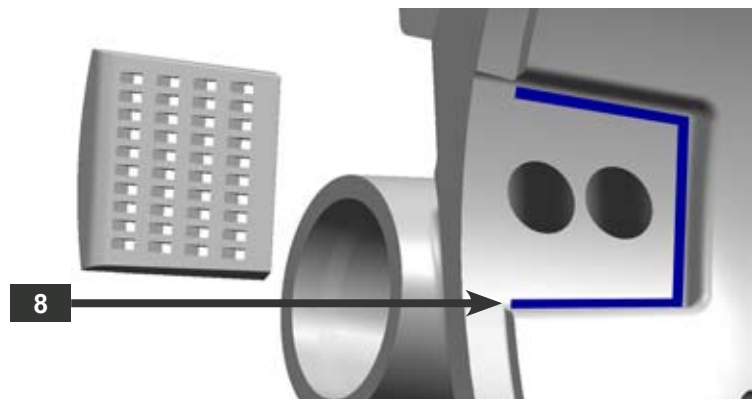



## 4.2 Removing Water Tube and Pump Wedge

- ➔ Replace seals (1) on water pipe and lubricate with marine grease.
- ➔ Observe orientation on pump wedge (2).  
The narrow side with the marking nose must face upwards.

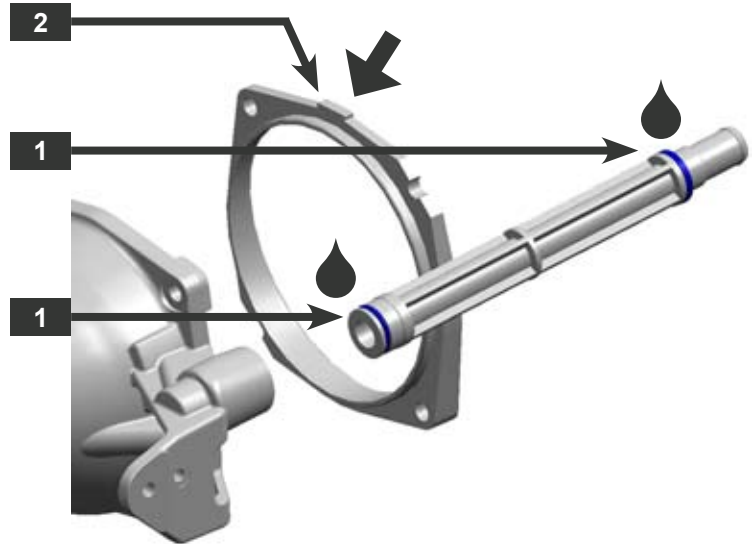

### 4.3 Removing Stator



#### WARNING

The freely rotating impeller can jam or sever fingers.

Never hold the jet pump on the impeller or reach in.

- 1) Remove M5 bolts (1).

- ➔ Tightening torque:  
4.5 Nm  $\pm$  10 % [3.3 ft. lb.]
- ➔ Use thread lock Loctite 243.

- 2) Remove pump cone (2) and seal (3).

- ➔ Replace seal.

- 3) Remove impeller (4) with mounting tool impeller.

- ➔ Tightening torque:  
138 Nm  $\pm$  10 % [101 ft. lb.]
- Use no grease or liquid thread lock to mount the impeller.
- ➔ Right-hand thread.
- ➔ After assembly, check movement of impeller.

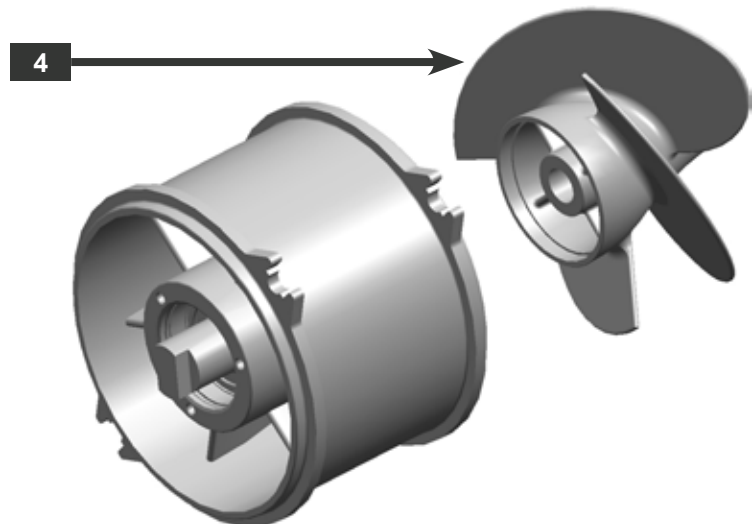
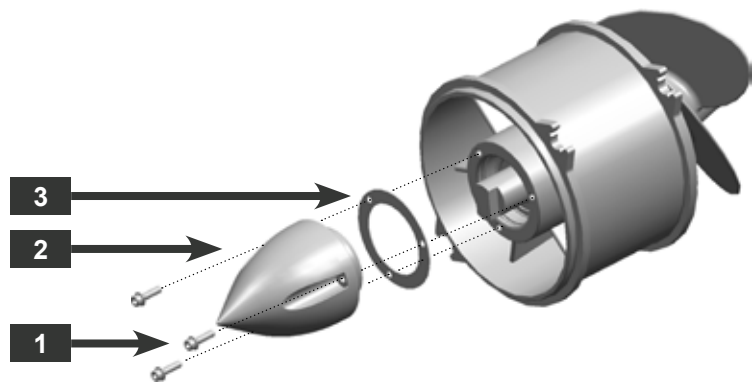

### Removing Stator (continuation)

- 4) Remove seal rings (5) (6) and sleeve (7).

- ➔ Replace seal rings.
- ➔ Fill seal ring (6) halfway with marine grease.
- ➔ Mount seal rings and sleeve with marine grease.
- ➔ Carefully mount seal rings to avoid damaging the seal.

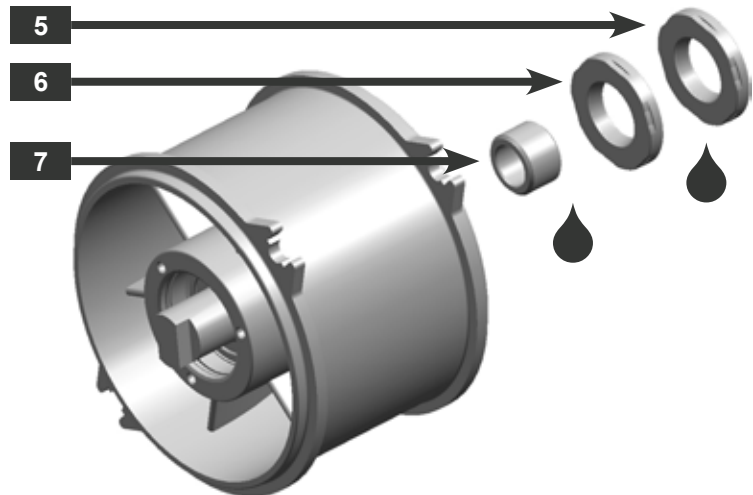

- 5) Remove bearing (8) and sleeve (9).

- ➔ Replace bearing (8).
  - ➔ Measure length of sleeve (9). If the sleeve measures less than the minimum size of 43.94 mm [1.730 in.], the sleeve must be replaced.
  - ➔ Installation of the bearing always occurs on a large-area on both bearing shells.
- Note the correct order during mount the bearings. Mount bearing (8) and sleeve (9) after bearing (12).
- ➔ Mount bearing and sleeve with marine grease.

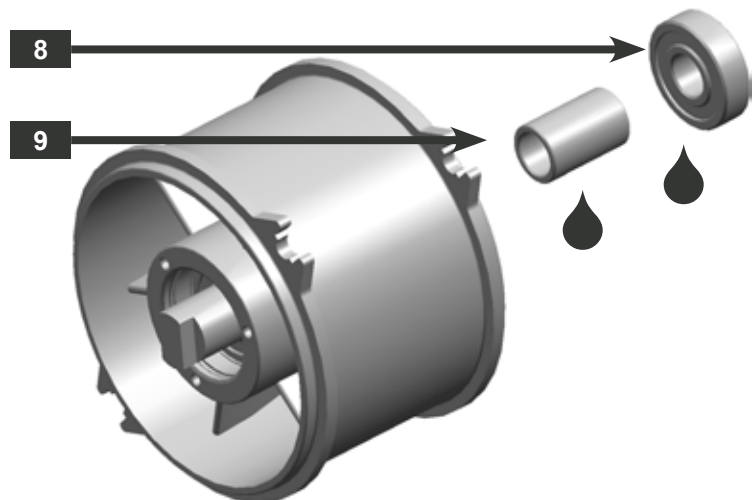

If the sleeve measures less than the minimum size, the acceptable axial load of the bearings is exceeded. This causes the bearings to wear out sooner.



## Removing Stator (continuation)

6) Remove stub shaft.

- ➔ Replace O-rings (10) on stub shaft and lubricate with marine grease.

7) Remove O-ring (11).

- ➔ Replace O-rings (10) in stator housing and lubricate with marine grease.

8) Remove bearings (12).

- ➔ Replace bearing.
- ➔ Installation of the bearing always occurs on a large-area on both bearing shells.  
Press the bearing as far as it will go in the stator.  
Note the correct order during mount the bearings. Mount bearing (12) first.
- ➔ Mount the bearing with marine grease.





## 5 Aligning the engine within the vehicle



- Alignment Laser Tool Case



This chapter is only valid in conjunction with a Weber Automotive GmbH engine.



The engine must be aligned within the vehicle, if ...  
... the engine was removed.  
... the engine mounts were removed or replaced.



### WARNING

Rotating parts on the driveshaft and the impeller can cause serious lacerations.

Before beginning work of any kind on the jet pump, remove ignition key and lanyard and detach cable on battery from negative terminal.

- 1) Remove jetpump (1) and driveshaft with seal (2) and if existant, damping bearing from the vehicle.

See chapter removing the jetpump from the vehicle and removing driveshaft.

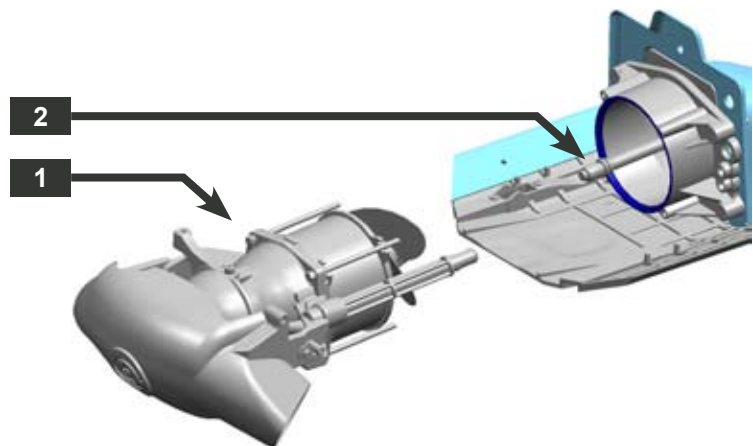

- 2) Remove drive coupler (3).

See chapter removing drive coupler.

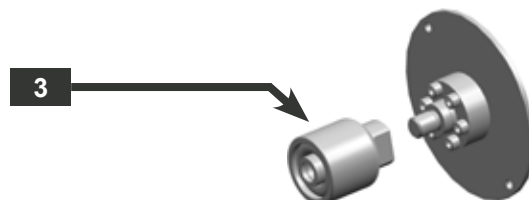





## Aligning the engine within the vehicle (continuation)



### WARNING

The alignment laser (4) is in accordance with class 2 international standards. The maximum value of average radiant power is 1 mW. The visible colour is red.

The laser beam of the alignment laser can cause eye damage.

- Do not look into the laser beam (5).
- Never direct the laser beam at other people.
- The alignment laser has no on/off switch. If the power supply is connected, the alignment laser is in operation. Do not connect the power supply (6) until all preparation has been done.
- If signs of damage are shown discontinue use.
- Do not remove the warning labels from the alignment laser.

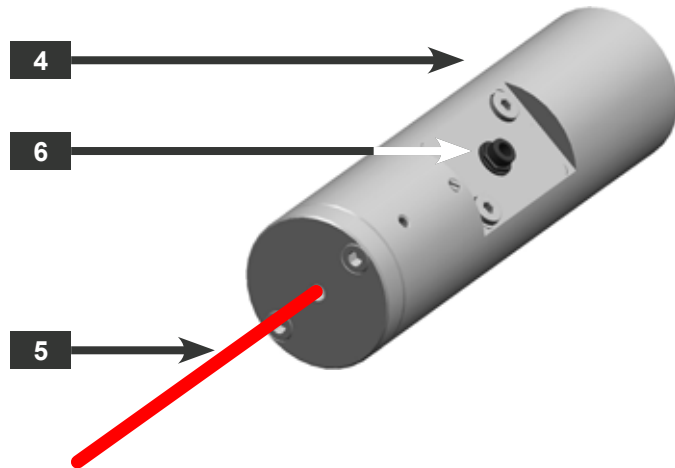

### Aligning the engine within the vehicle (continuation)

- 3) Screw the alignment laser (4) onto stub shaft.
- 4) Screw the pump reflector (7) onto housing with bolts 3/8 - 16 UNC - 2B. Observe the orientation. Reflector area (8) in direction of the engine.
- 5) Unfix the bolts at the engine mounts (9) a little bit. Remove existant shims.

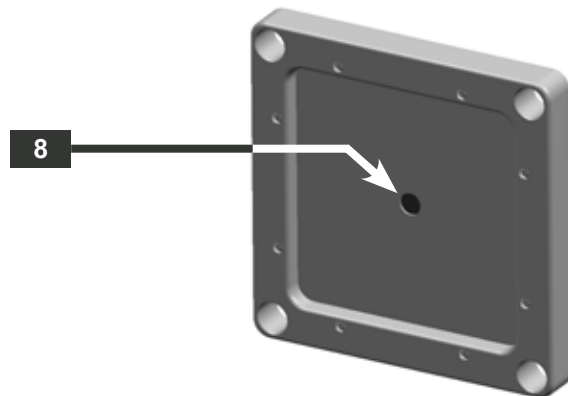
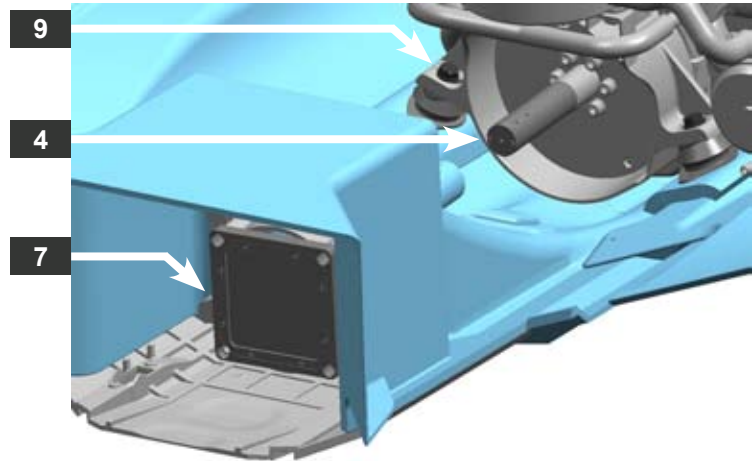

- 6) Check the voltage adjustment on the power supply unit (10); the rotary switch is located at the bottom (11) of the power supply unit.  
Necessary supply voltage of the alignment laser: 3 V
- 7) Connect the power supply unit with the alignment laser.
- 8) Connect the power supply unit with 230 V ~ power supply.

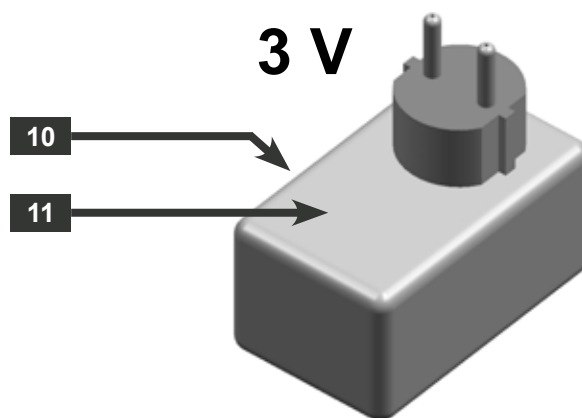

Wrong voltage adjustment can cause damage to the alignment laser.



### Aligning the engine within the vehicle (continuation)

- 9) The laser point must hit within the reflector area (12).
- 10) Work step 1  
Align engine vertically (13):  
Shake engine gently.
- 11) Work step 2  
Align engine horizontally (14):  
Add shims (15) between engine mounts and engine brackets.

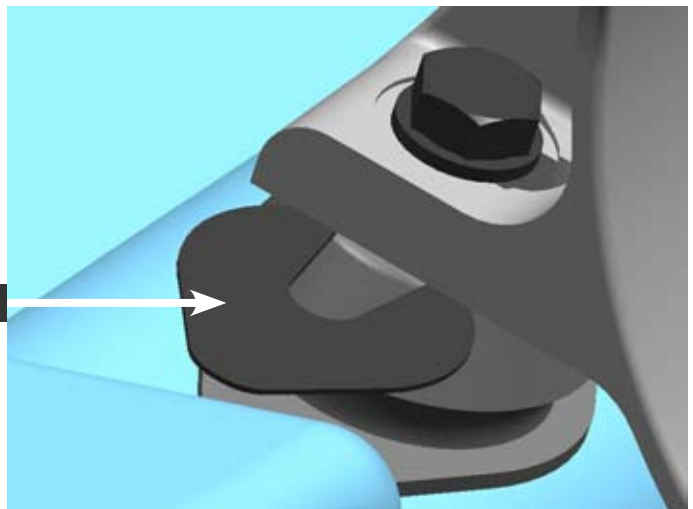
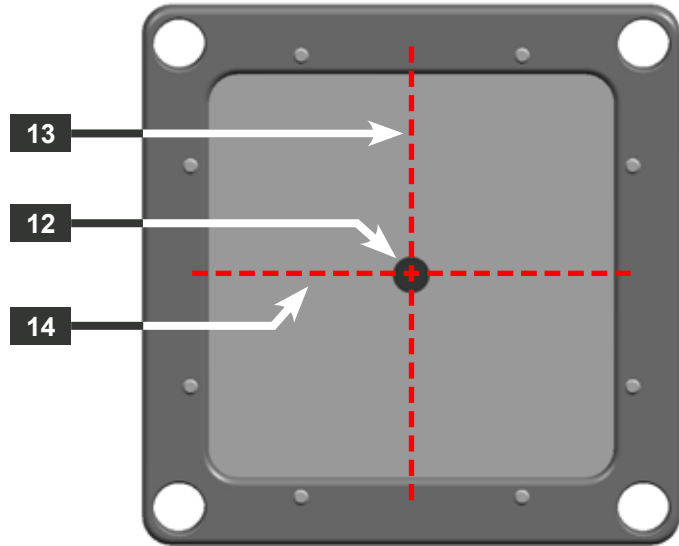

- 13) If the laser point hits within the reflector area (12) it reflects.  
It must be hit inside the alignment laser area (16).
- 14) Work step 3  
Align the engine with shims (15).

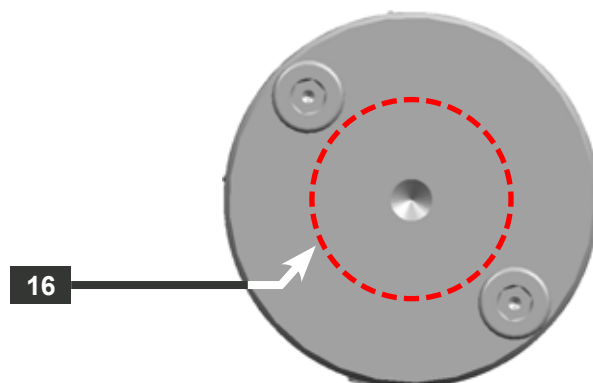



### **Aligning the engine within the vehicle (continuation)**

- 15) Disconnect power supply unit. Remove alignment laser and pump reflector.
- 16) Assemble drive coupler, driveshaft and jetpump.
- 17) Check axial clearance of the driveshaft.

See chapter checking driveshaft.



Too little axial clearance causes severe damage to engine and / or jetpump.



## Terminology

### A

---

Aligning the engine within the vehicle 14

### B

---

Before you begin working 1

### D

---

Disassembling the jet pump 8

Drive Coupler, removing 7

Driveshaft, checking 6

Driveshaft, removing 5

### E

---

Equipment 1

### G

---

Grate, removing 4

### H

---

Housing, removing 3

### I

---

Inlet Scoop, removing 4

### M

---

Marine grease 1

### P

---

Pump Wedge, removing 10

### R

---

Removing the jet pump from the vehicle 2

Reverse Gate, removing 8

Rideplate, removing 4

### S

---

Sealing agent 1

Special Tools 1

Steering Nozzle, removing 8

### W

---

Water Tube, removing 10

Manufacturer: Weber Automotive GmbH

Address: Otto-Lilienthal-Str. 5  
88677 Markdorf  
Germany

Internet: [www.weber-automotive.com](http://www.weber-automotive.com)