

# Champion®



## *Installation/Operation Guide with Service Replacement Parts*

*For machines built from 8.21.09 and above*

### **Eseries High Temperature Heat Recovery Unit**

Model:  
**HRU**

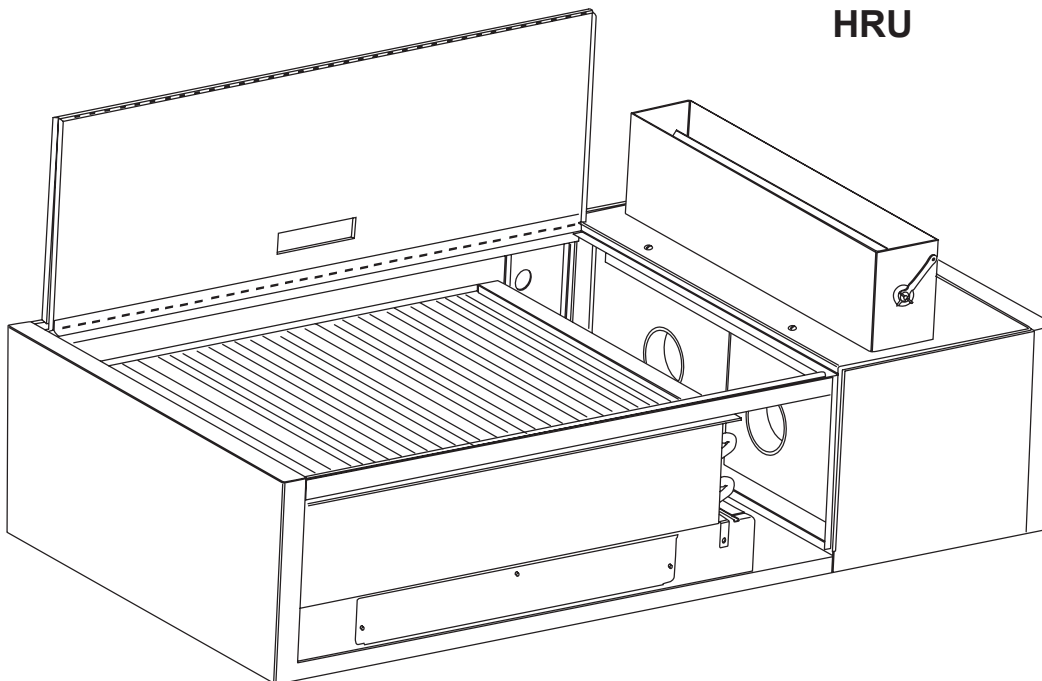

3765 Champion Blvd.,  
Winston-Salem, NC 27105  
336/661-1556 Fax: 336/661-1660  
[www.championindustries.com](http://www.championindustries.com)

2674 N. Service Road,  
Jordan Station Ontario, Canada L0R 1S0  
905/562-4195 Fax: 905/562-4618



*Issue Date: 2.18.11*  
**Manual P/N 114819 rev.A**

Printed in the USA



For future reference, record your dishwasher information in the box below.

Model Number _____	Serial Number _____
Voltage _____ Hertz _____	Phase _____
Champion Service Agent _____	Tel: _____
Champion Parts Distributor _____	Tel: _____

**ATTENTION:**  
The dishwasher model no., serial no., voltage, Hz and phase are needed to identify your machine and to answer questions.  
  
Please have this information on-hand if you call for service assistance.



For all models:  
The data plate mounts to one side of the top-mounted control cabinet.

**National Service Department**

 	
<b>In Canada:</b> Toll-free: 800/ 263-5798 Tel: 905/ 562-4195 Fax: 905/ 562-4618 email: <a href="mailto:service@moyerdiebellimited.com">service@moyerdiebellimited.com</a>	<b>In the USA:</b> Toll-free: 800/ 858-4477 Tel: 336/ 661-1556 Fax: 336/ 661-1660 email: <a href="mailto:service@championindustries.com">service@championindustries.com</a>

*The USGBC and the CaGBC Member Logos are trademarks owned by the U.S. Green Building Council and The Canadian Green Building Council, respectively, and are used by permission.  
The logos signify only that Champion Industries is a USGBC member and a CaGBC member; USGBC and CaGBC do not review, certify nor endorse the products or services offered by its members.*

## Revision History

The revision history contains part number changes and instructions not available at the time of printing. We reserve the right to make any changes without notice and without incurring any liability by making these changes.

Equipment owners may request a revised manual at no charge, by calling:  
1 (800) 858-4477 in the U.S.A. or by calling 1 (800) 263-5798 in Canada.

<b>Revision Date</b>	<b>Revised Pages</b>	<b>Serial Number Effectivity</b>	<b>Revision Description</b>
8.6.10	All	Engineered System	Release of First Edition
2.18.11	12-13	J11022850	Added blower junction box
	14-21	J11022850	Added 2 amp circuit breaker
	31	J10022850	Revised schematic for circuit breaker

## LIMITED WARRANTY

Champion Industries Inc. (herein referred to as Champion), 3765 Champion Blvd., Winston-Salem, North Carolina 27105, and P.O. Box 301, 2674 N. Service Road, Jordan Station, Canada, L0R 1S0, warrants machines, and parts, as set out below.

**Warranty of Machines:** Champion warrants all new machines of its manufacture bearing the name "Champion" and installed within the United States and Canada to be free from defects in material and workmanship for a period of one (1) year after the date of installation or fifteen (15) months after the date of shipment by Champion, whichever occurs first. [See below for special provisions relating to glasswashers.] The warranty registration card must be returned to Champion within ten (10) days after installation. If warranty card is not returned to Champion within such period, the warranty will expire after one year from the date of shipment.

Champion will not assume any responsibility for extra costs for installation in any area where there are jurisdictional problems with local trades or unions.

If a defect in workmanship or material is found to exist within the warranty period, Champion, at its election, will either repair or replace the defective machine or accept return of the machine for full credit; provided; however, as to glasswashers, Champion's obligation with respect to labor associated with any repairs shall end (a) 120 days after shipment, or (b) 90 days after installation, whichever occurs first. In the event that Champion elects to repair, the labor and work to be performed in connection with the warranty shall be done during regular working hours by a Champion authorized service technician. Defective parts become the property of Champion. Use of replacement parts not authorized by Champion will relieve Champion of all further liability in connection with its warranty. In no event will Champion's warranty obligation exceed Champion's charge for the machine. The following are not covered by Champion's warranty:

- a. Lighting of gas pilots or burners.
- b. Cleaning of gas lines.
- c. Replacement of fuses or resetting of overload breakers.
- d. Adjustment of thermostats.
- e. Adjustment of clutches.
- f. Opening or closing of utility supply valves or switching of electrical supply current.
- g. Cleaning of valves, strainers, screens, nozzles, or spray pipes.
- h. Performance of regular maintenance and cleaning as outlined in operator's guide.
- i. Damages resulting from water conditions, accidents, alterations, improper use, abuse, tampering, improper installation, or failure to follow maintenance and operation procedures.
- j. Wear on Pulper cutter blocks, pulse vanes, and auger brush.

*Examples of the defects not covered by warranty include, but are not limited to:* (1) Damage to the exterior or interior finish as a result of the above, (2) Use with utility service other than that designated on the rating plate, (3) Improper connection to utility service, (4) Inadequate or excessive water pressure, (5) Corrosion from chemicals dispensed in excess of recommended concentrations, (6) Failure of electrical components due to connection of chemical dispensing equipment installed by others, (7) Leaks or damage resulting from such leaks caused by the installer, including those at machine table connections or by connection of chemical dispensing equipment installed by others, (8) Failure to comply with local building codes, (9) Damage caused by labor dispute.

**Warranty of Parts:** Champion warrants all new machine parts produced or authorized by Champion to be free from defects in material and workmanship for a period of 90 days from date of invoice. If any defect in material and workmanship is found to exist within the warranty period Champion will replace the defective part without charge.

**DISCLAIMER OF WARRANTIES AND LIMITATIONS OF LIABILITY. CHAMPION'S WARRANTY IS ONLY TO THE EXTENT REFLECTED ABOVE. CHAMPION MAKES NO OTHER WARRANTIES, EXPRESS OR IMPLIED, INCLUDING, BUT NOT LIMITED, TO ANY WARRANTY OF MERCHANTABILITY, OR FITNESS OF PURPOSE. CHAMPION SHALL NOT BE LIABLE FOR INCIDENTAL OR CONSEQUENTIAL DAMAGES. THE REMEDIES SET OUT ABOVE ARE THE EXCLUSIVE REMEDIES FOR ANY DEFECTS FOUND TO EXIST IN CHAMPION DISHWASHING MACHINES AND CHAMPION PARTS, AND ALL OTHER REMEDIES ARE EXCLUDED, INCLUDING ANY LIABILITY FOR INCIDENTALS OR CONSEQUENTIAL DAMAGES.**

Champion does not authorize any other person, including persons who deal in Champion Dishwashing machines to change this warranty or create any other obligation in connection with Champion Dishwashing Machines.

# Table of Contents

## Model HRU: Heat Recovery Unit

<i>Revision History</i> .....	<i>i</i>
<i>Limited Warranty</i> .....	<i>ii</i>
<i>Model Description</i> .....	<i>iv</i>
<b>Installation</b> .....	<b>1</b>
<i>Receiving</i> .....	<i>1</i>
<i>Mounting</i> .....	<i>3</i>
<i>Plumbing Connections</i> .....	<i>5</i>
<i>Setting the PRV's</i> .....	<i>6</i>
<i>Operation Lights and Exhaust Blowers</i> .....	<i>8</i>
<b>Operation</b> .....	<b>9</b>
<b>Cleaning</b> .....	<b>10</b>
<b>Service Replacement Parts</b> .....	<b>11</b>
<b>One Line Piping Diagram</b> .....	<b>29</b>
<b>Operation Logic Diagram</b> .....	<b>33</b>
<b>Electrical Schematic</b> .....	<b>34</b>

*Model Description*

Model: **HRU** Heat Recovery Unit

The HRU heats cold water supplied to the dishwasher's built-in heat exchanger which raises the incoming temperature to approximately 110°F/43°C. The preheated water is plumbed to the final rinse water booster which ensures a minimum final rinse water temperature of 180°F/82°C to sanitize the clean wares. The HRU significantly reduces the energy required to heat water for the final rinse operations.

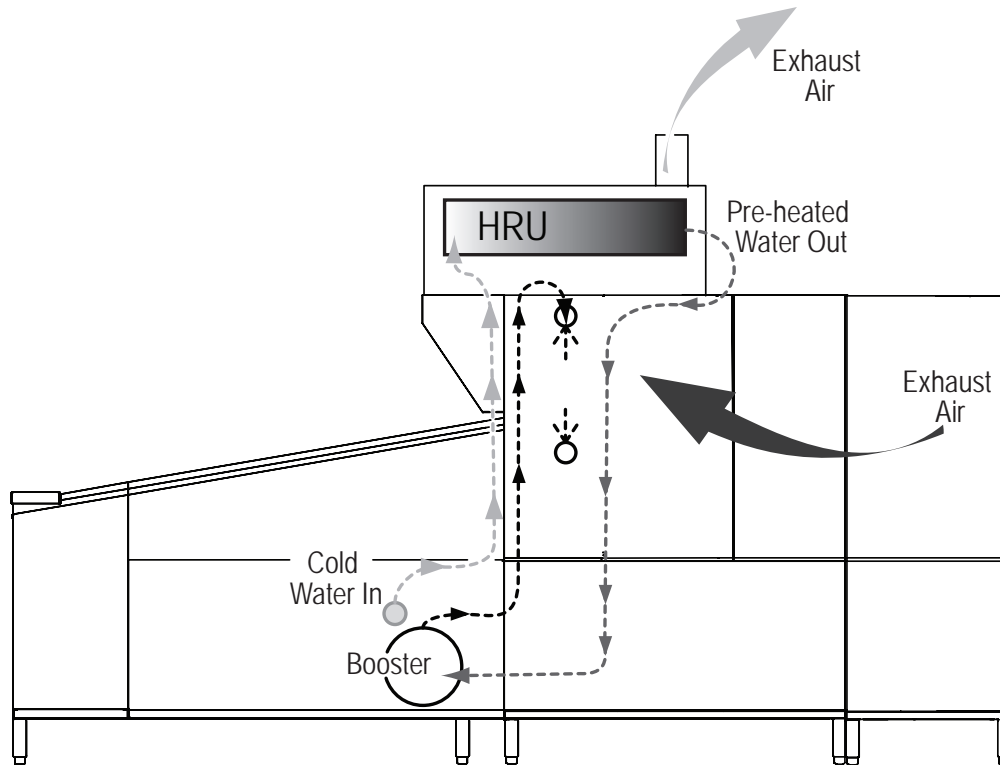

*The installation, and initial start-up of your dishwasher must be performed by qualified electricians, plumbers, and authorized service technicians trained in commercial dishwashers.*

*Defects and repairs caused by unauthorized installers will not be covered by the dishwasher warranty.*

## Installation

### Receiving

**NOTE:**

The installation of your Heat Recovery Unit (**HRU**) must be performed by qualified service personnel. Problems due to improper installation are not covered by the Warranty.

The HRU may have been installed at the factory. Proceed to the operation section of this manual if your HRU is already attached to the machine.

1. Inspect the HRU for damage due to shipping.
2. Check for any accessories that may have shipped with your dishwasher.
3. Move the HRU near its permanent location.

**CAUTION:**

Be careful when lifting and moving the HRU to prevent damage to the machine.

**NOTE:**

The installation of the HRU must comply with local safety and health codes.

4. Compare the installation site utility connections with the dishwasher utility connections and make sure that they are the same.
5. For new dishwasher installations, install the Dishwasher according to the instructions in the dishwasher service manual *Installation, Operation, and Service Replacement Parts*, which is shipped inside the dishwasher.

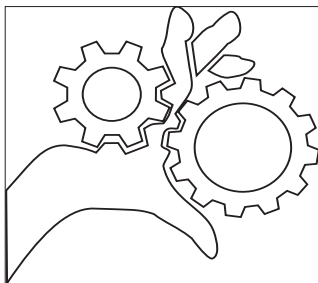

**WARNING:**  
Moving Parts may cause INJURY OR DEATH.  
USE EXTREME CAUTION WHEN THE CONVEYOR IS MOVING.



**WARNING:**  
Electrocution or serious injury may result when working on an energized circuit.  
Disconnect power at the main breaker or service disconnect switch before working on the circuit.  
Lock-out and tag the breaker to indicate that work is being performed on the circuit.

## Installation

### Receiving



**CAUTION:**

Metal edges in the HRU may be sharp. Use appropriate caution when working on and in the vicinity of metal components

**NOTE:**

The installation of the HRU must comply with local safety and health codes.

1. The HRU weighs approximately 175 lbs./79.4 Kg and mounts on the top of the unload end of the dishwasher.
2. The unload exhaust vent of the dishwasher connects to the inlet of the HRU vent and is sealed with gasket material which has already been installed on the dishwasher.
3. The HRU is attached to the dishwasher by inserting fasteners from inside the dishwasher into weldnuts mounted in the HRU. Mounting hardware is included in the installation kit.

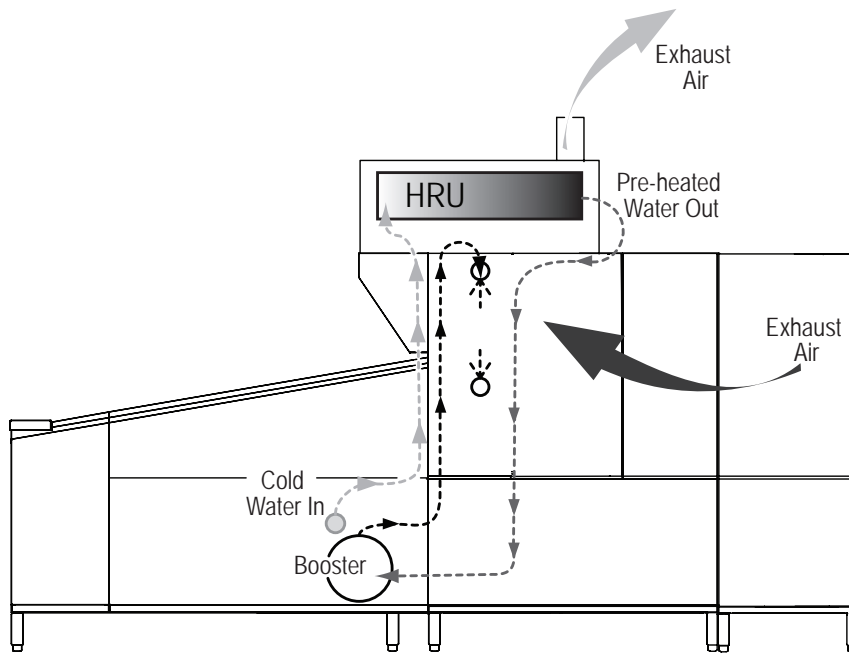

*Heat Recovery Unit (HRU) shown installed on a right-to-left dishwasher without a Blower Dryer Option*



## Installation

### Mounting

**NOTE:**

The HRU may have been mounted at the factory so the procedures described below may not be required.

1. Install the HRU after the dishwasher is completely assembled.
2. Lift the unit with a forklift or a minimum of four persons capable of positioning and lowering the HRU into its final position.
3. Make sure the HRU vent inlet (A) is centered on the dishwasher.
4. Install the mounting hardware installed in the installation kit from the inside of the dishwasher hood to secure the HRU to the machine.
5. The mounting hardware (B) includes: (7) Hex hd. bolts 1/4-20 x 5/8", (7) 1/4" split lock washers, and (7) 1/4" flat washers.

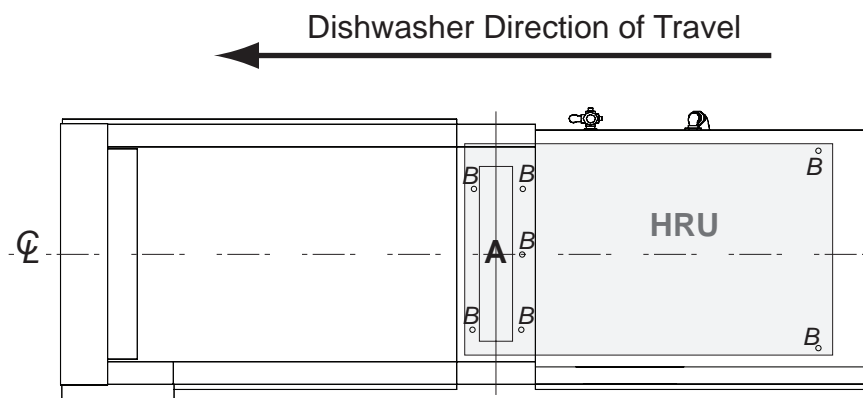

Top View of the dishwasher unload section.  
(HRU shown in gray)

6. Electrical power is prewired from the heat recovery control box to the dishwasher main control cabinet to operate the HRU.

***This Page  
Intentionally  
Left Blank***

## Installation

### Plumbing Connections

Refer to the photograph below and follow the instructions to connect the water lines to the HRU.

1. Connect compression fittings from the cold water supply line located at the base of the dishwasher booster heater to the HRU.
2. Connect compression fittings from the HRU return line at the rear of the HRU to the booster inlet located at the base of the machine.
3. Connect the red drain hose from the base of the HRU to the fitting on the rear drain line of the dishwasher. The fitting is located directly below the HRU drain line.

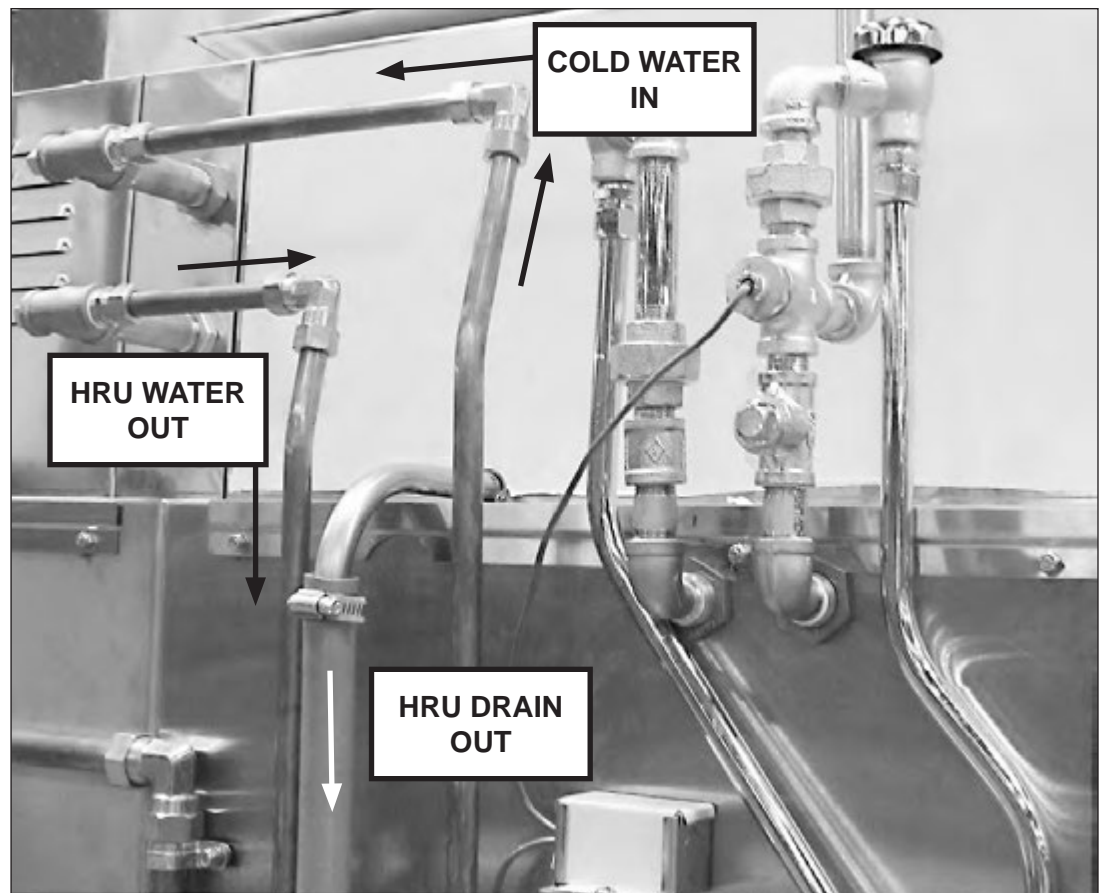

*Heat Recovery Unit (HRU) water and drain lines are connected at the rear of the dishwasher.*

## Installation

### Setting the Booster Pressure Reducing Valves (PRV's)

Refer to the illustrations on the next two pages for the location of the water valves and the Green indicator lights.

1. Ensure that all utility connections are complete.
2. Remove the lower front panel of the unload section.
3. Remove the coil assembly (A) from the multi-rinse valve.

**CAUTION:**

**to prevent damage to the valve coil, energize the multi-rinse valve for as short a period as needed to make necessary PRV adjustments.**

**Immediately reinstall the coil assembly when PRV adjustments have been completed.**

4. Turn on main water supplies to the dishwasher. Make sure steam supply is OFF.
5. Close all of the drain valves.
6. Remove the main control cabinet cover and set the Auto/Manual switch to the Manual position.
7. Turn ON main breaker power to dishwasher.
8. Turn OFF main breaker power to the booster and optional blower dryer (if equipped).
9. Turn dishwasher main power switch ON.
10. Allow dishwasher tanks to completely fill with water.
11. When dishwasher tanks are full, turn dishwasher main power switch OFF.
12. Turn the Auxiliary wash tank drain handle open and drain the tank (leave the drain open).  
(*This places the dishwasher in a FILL mode because the tank is empty.*)
13. Turn the dishwasher main power switch ON.
14. The Green FILL light in the control cabinet will be ON when the machine is filling.
15. While the machine is filling, adjust the HOT PRV #1 until the final rinse pressure gauge indicates 20 PSI. Tighten the PRV adjustment lock-nut to hold the setting.
16. Close the drain and allow the dishwasher to fill with water.
17. Turn the dishwasher main power switch OFF.
18. Make sure the main breaker or steam supply to the booster is OFF.  
Turn the hot water off.
19. Turn the dishwasher control panel Power Switch on.
20. Press the ENERGY SAVER mode selector switch on the main control cabinet.  
The green LED will illuminate and the conveyor will run.
21. While the machine is running, adjust the COLD PRV #2 until the final rinse pressure gauge indicates 20 PSI. Tighten the PRV adjustment lock-nut to hold the setting.
22. Now set the cold water PRV #2 by adjusting the PRV until the final rinse pressure gauge indicates 20 PSI flow pressure. Note that the pressure gauge will cycle on for 15 seconds and then off for 30; therefore, the pressure gauge will read a flowing pressure for 15 secs., then read the no pressure for 30 seconds.
23. The Green FINAL light will be ON when the Cold water valve is ON. The Green REHEAT light will be ON when the Hot water valve is ON.
24. To complete the settings: Turn the dishwasher main power switch OFF.
25. Turn the main breaker or steam supply to the booster on.
26. Turn the Automatic/Manual switch inside the control cabinet to the Automatic position.

## Installation

### Setting the Booster Pressure Regulating Valves (PRV's)

1. Reinstall the main control cabinet cover.
2. Reinstall the coil assembly on the multi-rinse valve (A).
3. Open all drain valves and drain the dishwasher.
4. Turn the hot water supply ON.
5. Makes sure the main power supply is ON.

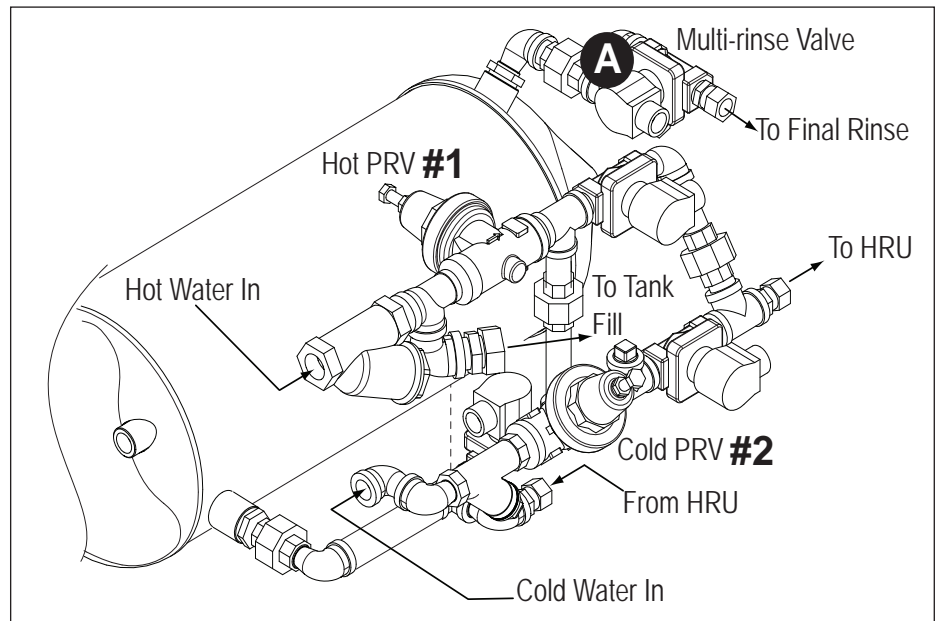

*Electric HRU Booster PRV Locations  
(Right-to-left dishwasher installation).*

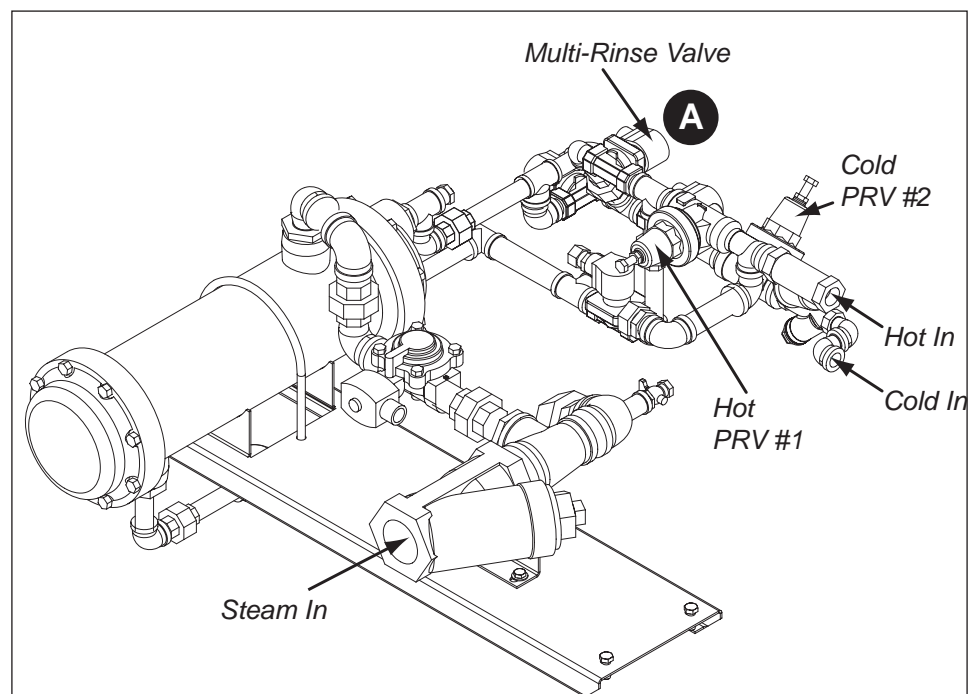

*Steam HRU Booster PRV Locations  
(Right-to-left dishwasher installation).*

## Installation

### Operation Indicator Lights

Green indicator lights inside the HRU control cabinet indicate the operation state of the valves during the set-up procedures. Refer to the set-up procedures on the previous two pages to set the pressure reducing valves.

In addition, the green lights will indicate the operation of the booster valves during normal operation. Refer to the simplified logic diagram below which shows the interaction of the timers, thermistor reader (temperature control module) and the booster solenoid valves.

### Exhaust Blowers

The HRU Exhaust Blowers operate when the dishwasher is running.

**Exhaust Blower 1:** runs whenever the dishwasher pumps and the final rinse are running.

**Exhaust Blower 2:** runs when only the final rinse is running.

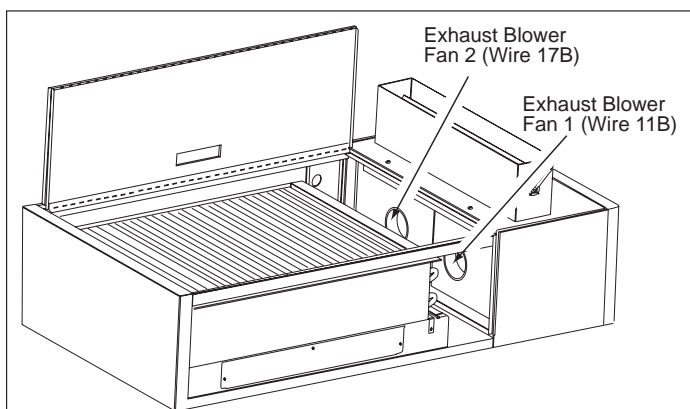

Exhaust Blowers as viewed from the front of the dishwasher.  
(Left-to-Right Dishwasher Operation Shown)

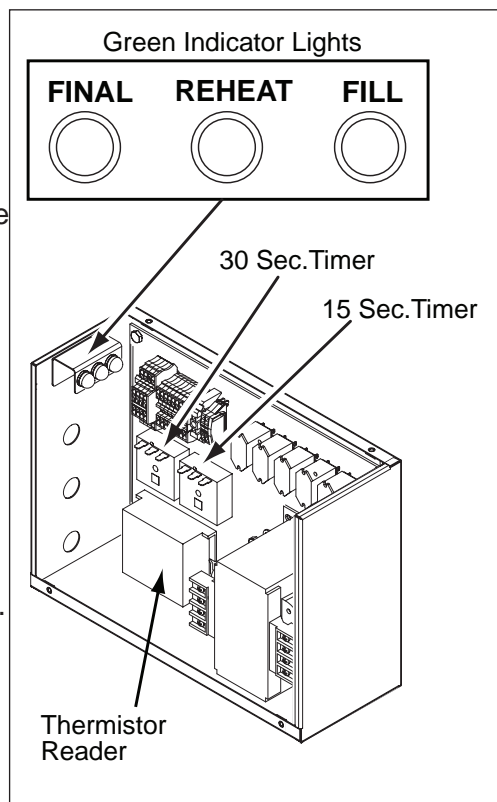

Indicator lights inside the control cabinet indicate the operation of the valves.

**NOTE:**  
A detailed Logic Diagram is included at the end of this manual

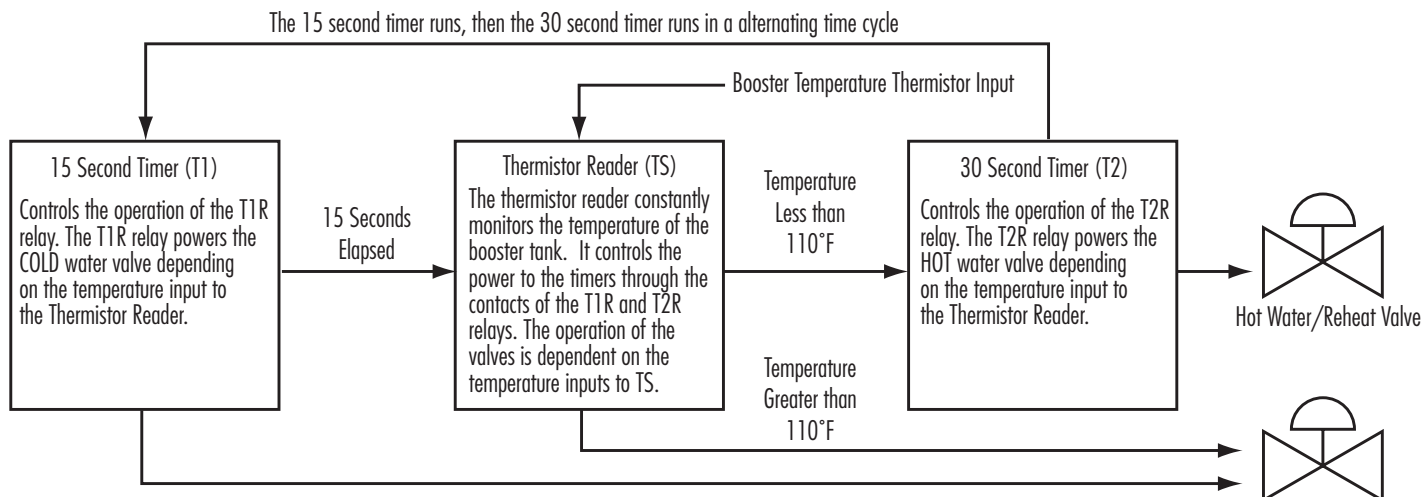

Simplified HRU Cold and Hot Water Switching Logic Diagram

**Operation****NOTE:**

The operation of the HRU is automatically controlled by the dishwasher control circuit. The HRU has a control that is accessed only by a trained service technician.

Refer to the illustration below to prepare the HRU for operation.

1. Open the top cover of the HRU and remove any foreign objects.  
(Refer to the cleaning section on the next page for detailed cleaning instructions.)
2. Make sure the access cover is in place and secured by its retaining studs.
3. Make sure the vent adjustment handle is secure and set to its normal operating position.

**Automatic Operation:**

1. The HRU operates whenever the dishwasher pumps run.
2. Hot air from the dishwasher interior is recycled through the HRU and exhausted from the HRU vent which has been permanently connected to the building vent system.
3. A small amount of exhaust air may exit the unload end of the dishwasher. This is a normal condition.
4. The HRU is off whenever the dishwasher pumps are not running.

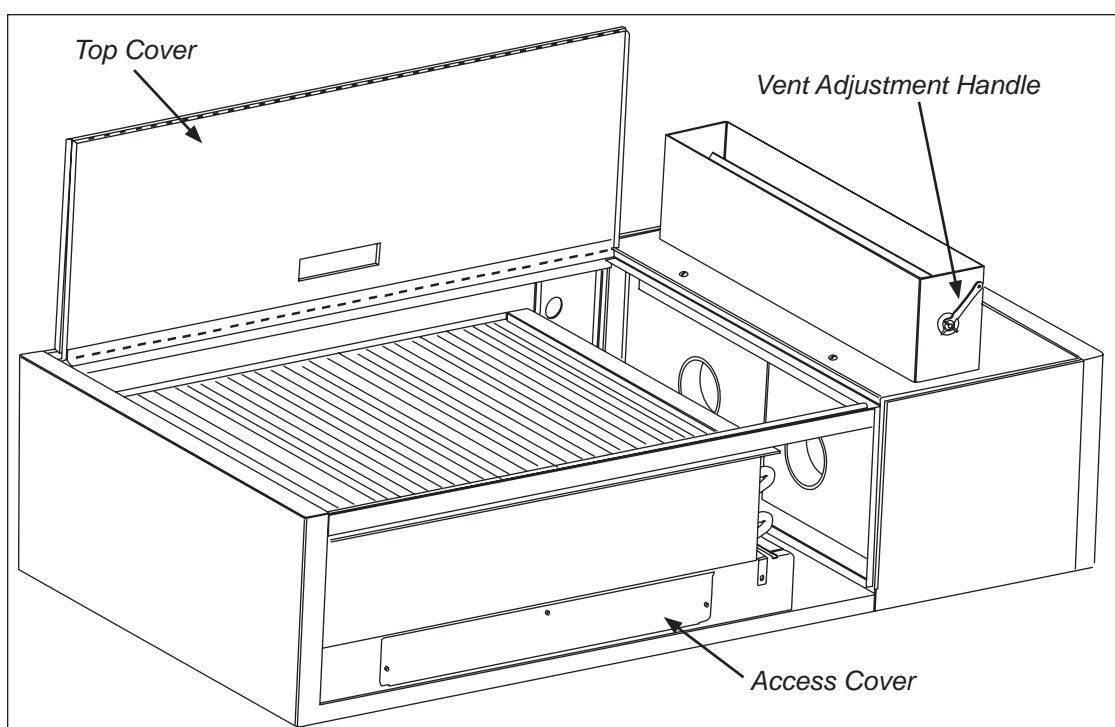

## Cleaning

### CAUTION:

Do not place objects on top of the condenser coil nor with the cleaning devices. Avoid the use of cleansers or other detergents to prevent damage to the top of the coil

Refer to the illustration below.

### Monthly Cleaning Schedule:

1. Open the top cover over of the HRU.
2. Remove the front cover of the unit by sliding it up.
3. Remove the front access cover which is retained by three knurled thumbscrews.
4. Flush the top of the condenser coil with fresh water.
5. Do not wipe nor brush the coil fins.
6. Flush the underside below the condenser coil with fresh water.
7. Leave the HRU covers off overnight to allow the inside of the unit to air dry.
8. Reassemble in reverse order at the beginning of the day.

### Daily Cleaning Schedule:

1. Inspect the interior unit for accumulated debris.
2. Wipe the exterior of the unit with a soft cloth and mild detergent.
3. **DO NOT HOSE THE EXTERIOR OF THE UNIT WITH WATER.**

### Annual Cleaning Schedule:

1. Contact an authorized service agent to perform general maintenance and major cleaning.

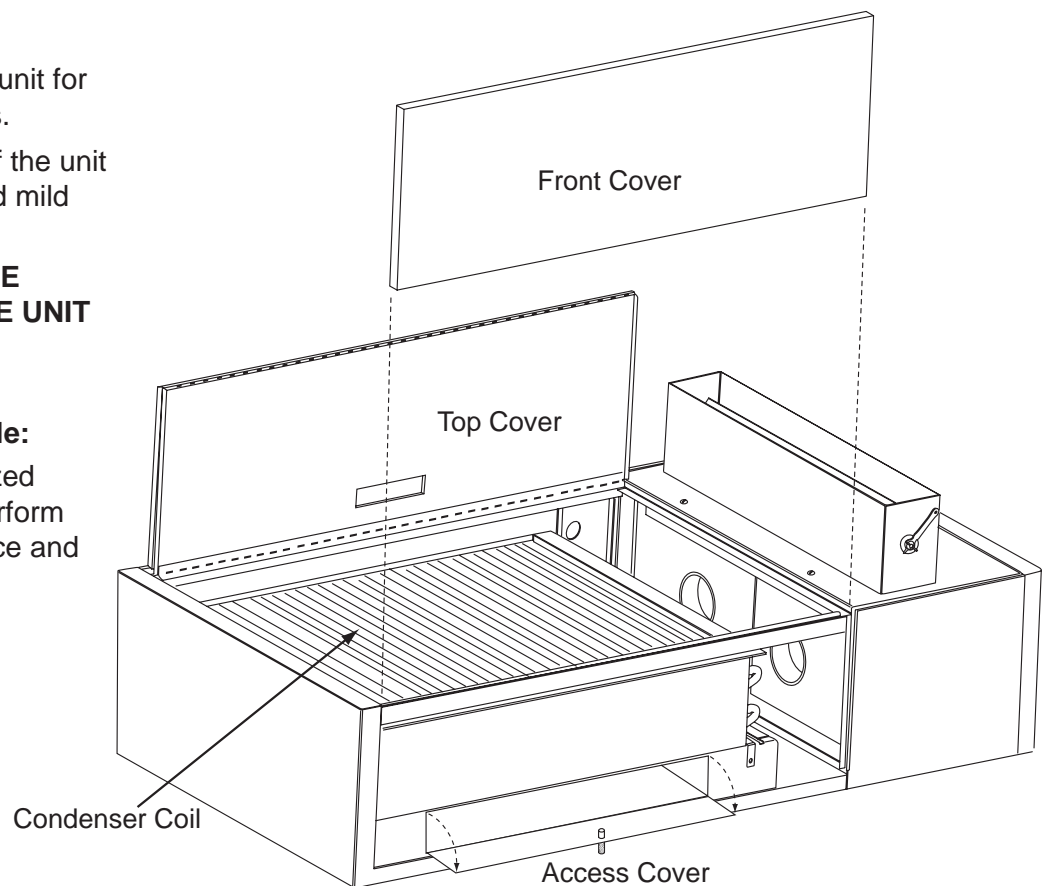



# Service Replacement Parts

Illustrations	Page
Heat Recovery Unit .....	12
Control Cabinet - Prior to S/N J11022850 .....	14
Control Cabinet Terminal Block - Prior to S/N J11022850 .....	16
Control Cabinet - Beginning with S/N J11022850 and above.....	18
Control Cabinet Terminal Block - Beginning with S/N J11022850 and above .....	20
HRU Electric Booster Assembly .....	22
HRU Electric Booster Piping.....	24
HRU Steam Booster Assembly.....	26
HRU Steam Booster Piping .....	28

Heat Recovery Unit

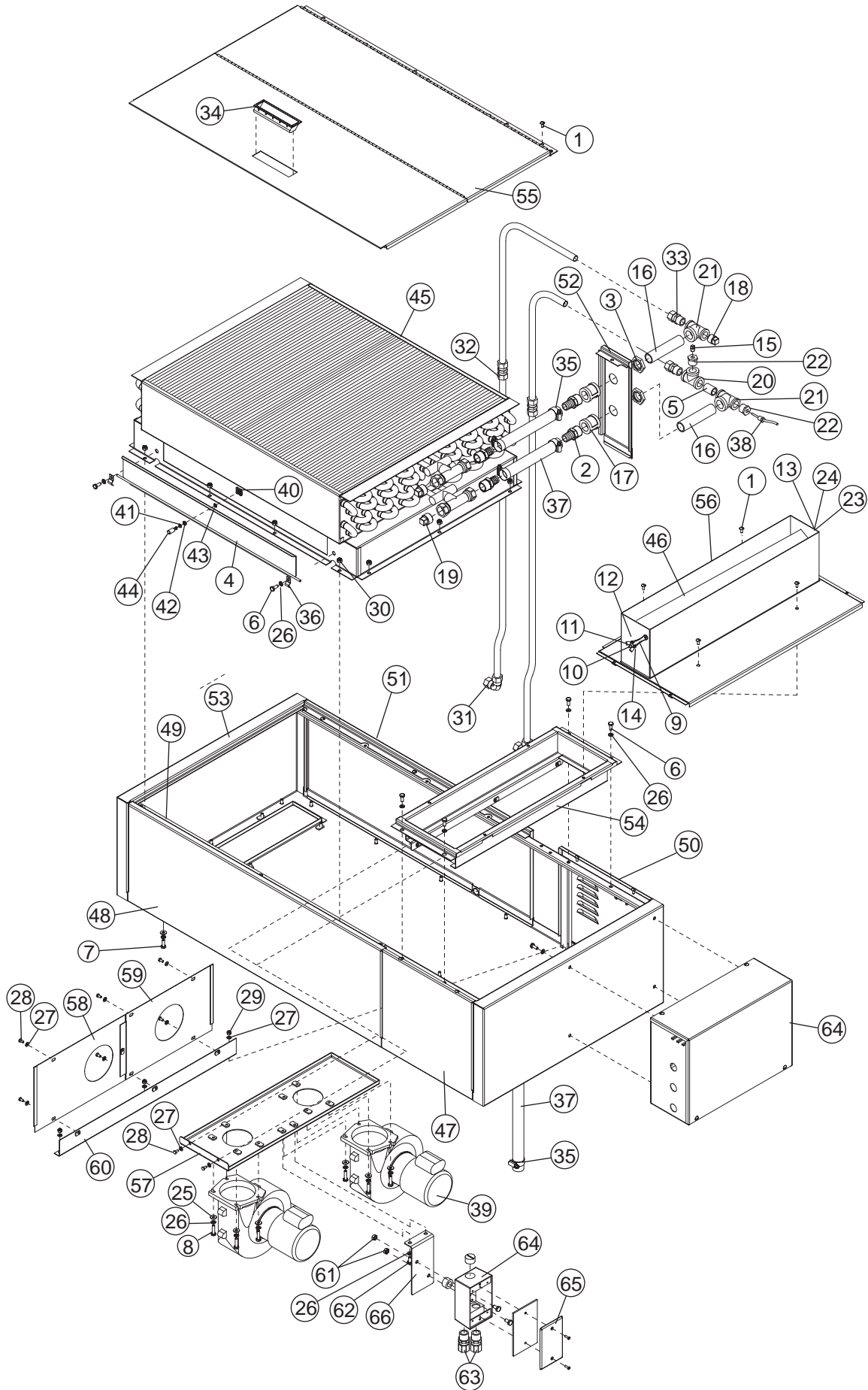

Item No.	Part No.	Description	Qty.
1	100097	SCREW, TRUSS HD., 10-32 X 1/2" SST	20
2	0512027	COUPLER, BARB 3/4" MPT X 3/4" HOSE	4
3	100156	LOCKNUT, 3/4" NPT BRASS	2
4	333557	ACCESS PLATE WELDMENT, HRU PLENUM G3	2
5	100209	NIPPLE, 1/2" NPT X CLOSE BRASS	1
6	100735	BOLT, HEX HD., 1/4-20 X 5/8" SST	12
7	100736	BOLT, HEX HD., 1/4-20 X 3/4" SST	7
8	100738	BOLT, HEX HD., 1/4-20 X 1" SST	8
9	101187-1	HANDLE, THREADED DAMPER ASSY.	1
10	101187-2	HANDLE, DAMPER ASSY.	1
11	101187-3	WING NUT, DAMPER REGULATOR ASSY.	1
12	101187-4	WASHER, DAMPER REGULATOR ASSY.	1
13	101187-5	BRACKET ASSY., LOCK PIN DAMPER REGULATOR	1
14	101187-6	BEVELLED WASHER, DAMPER ASSY.	1
15	101259	PLUG, 1/8" NPT SQ. HD., BRASS	1
16	101502	NIPPLE, RTOE 3/4" NPT X 4-1/2" LG. BRASS	2
17	102415	COUPLING, 3/4" NPT BRASS	2
18	102504	PLUG, 1/2" NPT SQ. HD., BRASS	1
19	102505	PLUG, 3/4" NPT SQ. HD., BRASS	2
20	102514	TEE, 1/2" NPT BRASS	1
21	102519	TEE RED., 1/2" X 1/2" X 3/4" BRASS	2
22	103418	BUSHING, REDUCING, 1/2" NPT X 1/8" NPT BRASS	2
23	104883	SCREW, ROUND HD., 6-32 X 3/8" SST	4
24	104971	HEX GRIP NUT, 6-32" SST	4
25	106026	WASHER, FLAT SST	15
26	106482	WASHER, LOCK 1/4" SPLIT SST	27
27	107033	WASHER, FLAT SST	12
28	107136	SCREW, HEX HD., 10-32 X 3/8" SST	9
29	107966	HEX GRIP NUT, 10-32 W/NYLON INSERT	3
30	107967	HEX GRIP NUT, 1/4-20 W/NYLON INSERT	14
31	109910	FITTING, COMP 5/8" OD X 90° BRASS	2
32	109924	FITTING, COMP 5/8" OD UNION BRASS	2
33	109925	FITTING, COMP 5/8" OD X 1/2" MPT BRASS	2
34	111561	HANDLE, ACCESS DOOR, FLUSH MOUNT	1
35	113269	CLAMP, HOSE M12 11/16"-1-1/4" W/CS SCREW	6
36	333556	CLIP, ACCESS PLATE PIVOT, HRU PLENUM	4
37	114121	HOSE, 3/4" SYNTHETIC RUBBER	A/R
38	114335	THERMISTOR, 10KΩ, 36" LEAD	1
39	114633	BLOWER, HEAT RECOVERY UNIT	2
40	114646	RECEPTACLE, 1/4 TURN	2
41	114647	SPRING, 1/4 TURN SST	2
42	114648	WASHER, WEAR, CLIPPED	2
43	114649	RING, RETAINER SST	2
44	114650	STUD, 1/4 TURN, KNURLED SST	2
45	114710	COIL, BATTERY, HEAT RECOVERY UNIT GEN.3	1
46	305141	BLADE, DAMPER, VENT STACK	1
47	333143, (333216)	PANEL, FRONT FAN END, RL (LR NOT SHOWN)	1
48	333144, (333217)	PANEL, FRONT COIL END, RL (LR NOT SHOWN)	1
49	333145	ANGLE, FRONT PANEL STOP	1
50	333151, (333220)	PANEL, REAR, FAN END, RL (LR NOT SHOWN)	1
51	333152, (333221)	PANEL DEVP., REAR COIL END, RL (LR NOT SHOWN)	1
52	333153, (333222)	PANEL DEVP., REAR, CENTER, RL (LR NOT SHOWN)	1
53	333341, (333342)	BODY WELDMENT, HRU, RL (LR NOT SHOWN)	1
54	333345, (333346)	DUCT WELDMENT, OUTLET, RL (LR NOT SHOWN)	1
55	333350, (333351)	COIL COVER WELDMENT, RL (LR NOT SHOWN)	1
56	333353	PANEL WELDMENT, TOP VENT	1
57	333355, (333357)	PLATE WELDMENT, BLOWER MTG, RL (LR NOT SHOWN)	1
58	333358	PLATE DIVIDER, RH COIL CHAMBER	1
59	333359	PLATE WELDMENT, DIVIDER LH	1
60	333360	ANGLE DIVIDER MOUNTING	4
61	100141	HEX, GRIP NUT, 1/4-20 SST CTRL LOCK	2
62	100734	BOLT, HEX HD. 1/4-20 X 1/2" SST	4
63	114365	CONNECTOR, STRAIN RELIEF, CORD	2
64	114879	BOX, WEATHERPROOF, 4-HOLE	1
65	114880	COVER ASSY., WEATHERPROOF W/GASKET	1
66	334221	BRACKET, FAN JUNCTION BOX HRU	1

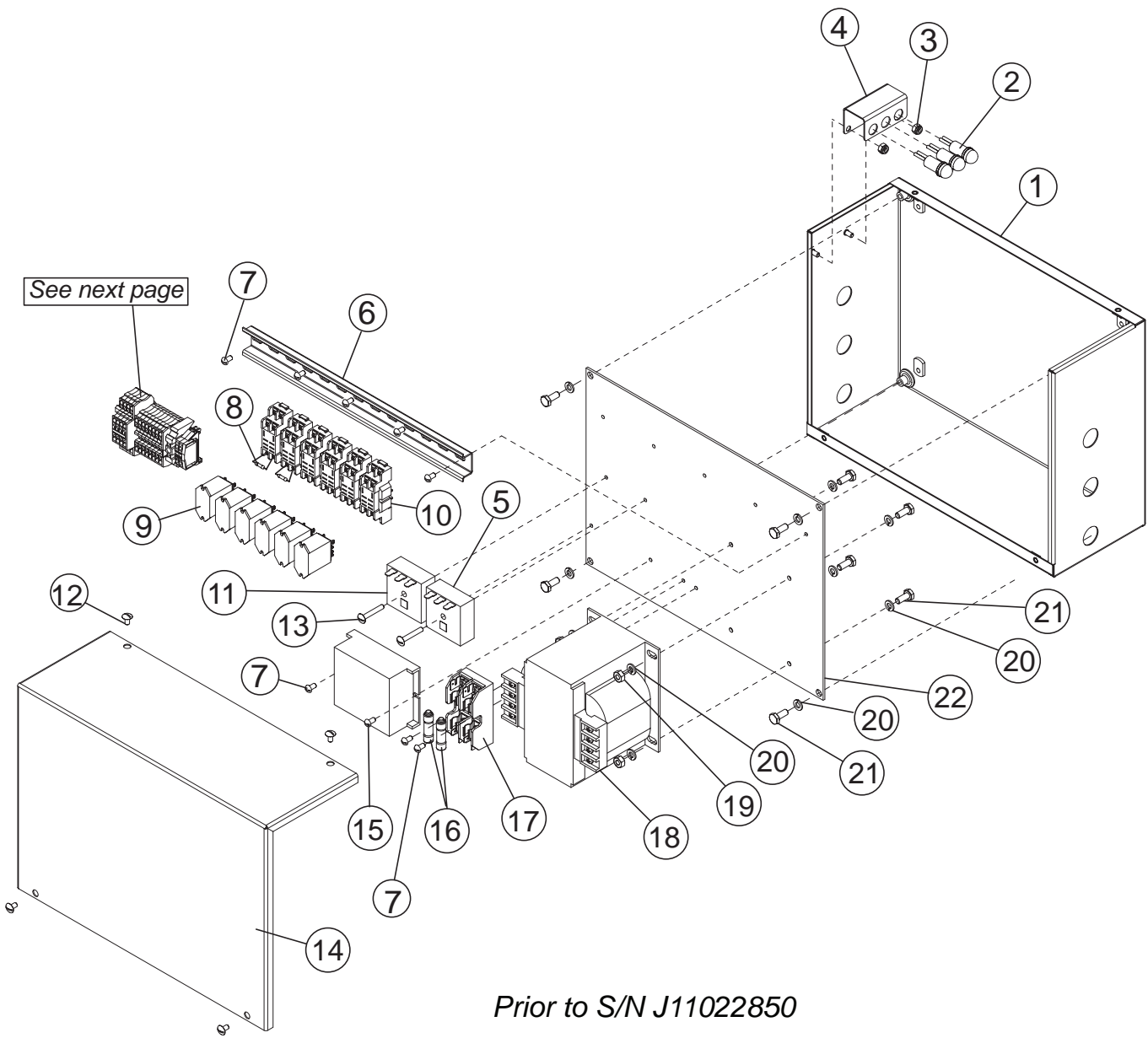

Item No.	Part No.	Description	Qty.
1	333305	CONTROL CABINET WELDMENT, HRU W/XFRM	1
2	106364	LIGHT, INDICATOR	3
3	107966	HEX GRIP NUT, 10-32 W/NYLON INSERT SST	2
4	333536	BRACKET, LIGHTS HRU CONTROL CABINET	1
5	114661	TIMER, FIXED 15 SECOND 120VAC	1
6	113769	DIN RAIL 35MM X 15MM	A/R
7	100095	SCREW, ROUND HD., 10-32 X 3/8" SST	9
8	114666	RESISTOR, 10Ω 2W	2
9	111068	RELAY, 2-POLE 10A, 120VAC	6
10	111036	SOCKET, RELAY 2 POLE	6
11	114662	TIMER, FIXED 30 SECOND 120VAC	1
12	100007	SCREW, TRUSS HD., 10-32 X 3/8" SST	4
13	106396	SCREW, TRUSS HD., 10-32 X 1-1/4" SST	2
14	333306	COVER, CONTROL CABINET HRU W/XFRM	1
15	114655	TEMPERATURE CONTROL MODULE, HRU	1
16	111823	FUSE, ATDR 6A	2
17	106402	BLOCK, FUSE 2 POLE	1
18	107091	TRANSFORMER, 500VA 240/480, 230/460:120	1
---	111521	TRANSFORMER, 250VA 575:120VAC	1
19	100003	HEX PLAIN NUT, 1/4-20 SST	4
20	106482	WASHER, LOCK, 1/4" SPLIT SST	12
21	100735	BOLT, HEX HD., 1/4-20 X 5/8" SST	8
22	333307	INNER PANEL, CONTROL CABINET HRU W/XFRM	1

Control Cabinet Terminal Block - Prior to S/N J11022850

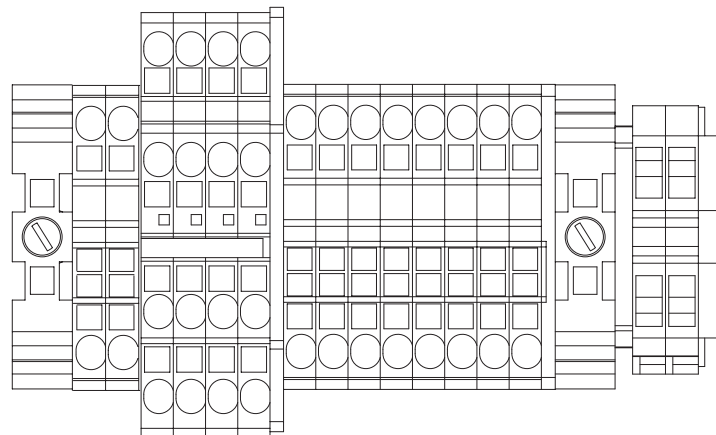
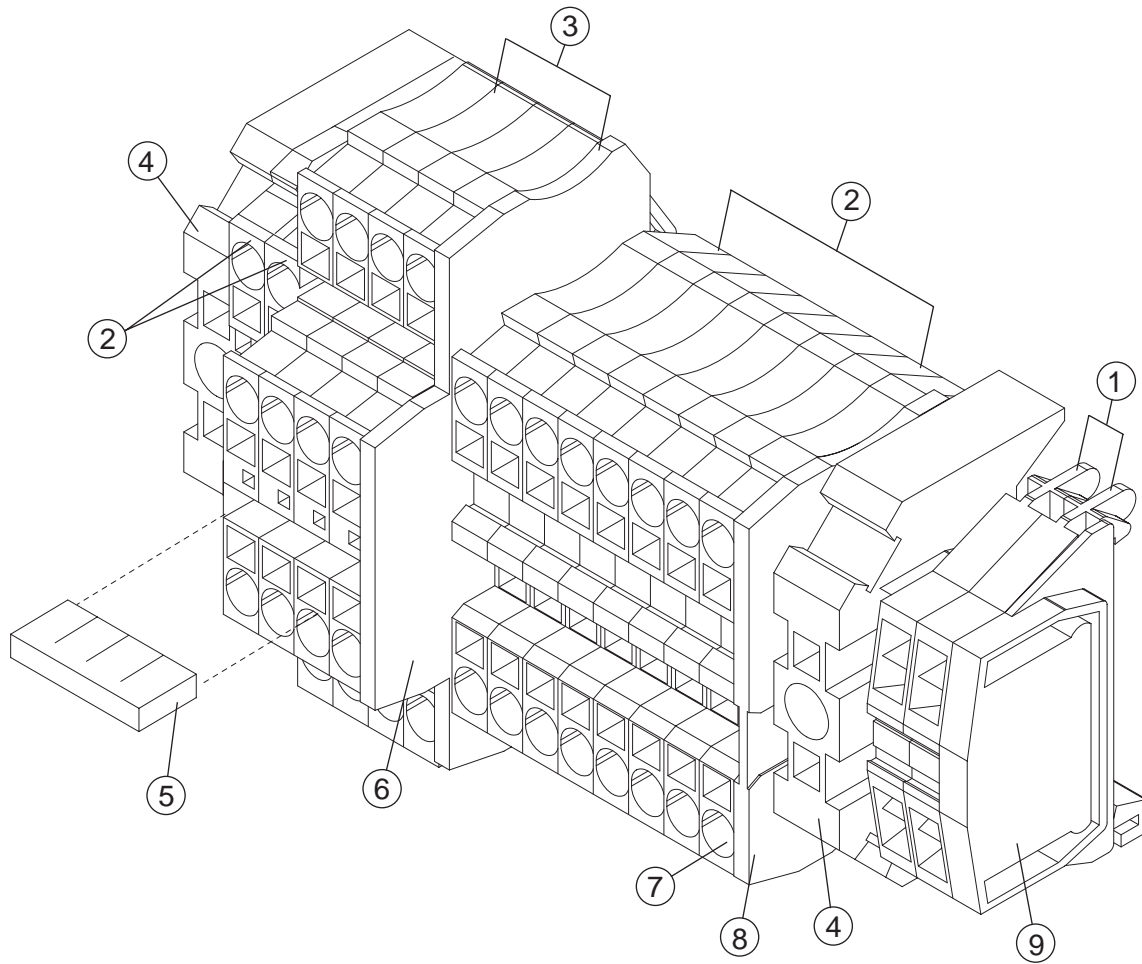

Item No.	Part No.	Description	Qty.
1	114520	TERMINAL, SINGLE MZB 1.5-NS35	2
2	114512	TERMINAL, SINGLE, ST 2.5 (GRAY)	9
3	114517	TERMINAL, DOUBLE STTB 2.5	4
4	114519	END BLOCK, E/NS 35N	2
5	114522	BUS BAR 4-POLE (CUT TO FIT)	1
6	114518	END COVER, DOUBLE TERMINAL, D-STTB 2.5	1
7	114515	TERMINAL, SINGLE GROUND, ST 2.5 PE (GREEN)	1
8	114516	END COVER, SINGLE TERMINAL D-ST 2.5	1
9	114521	END COVER, SINGLE TERMINAL D-MZB 1.5 NS35	1

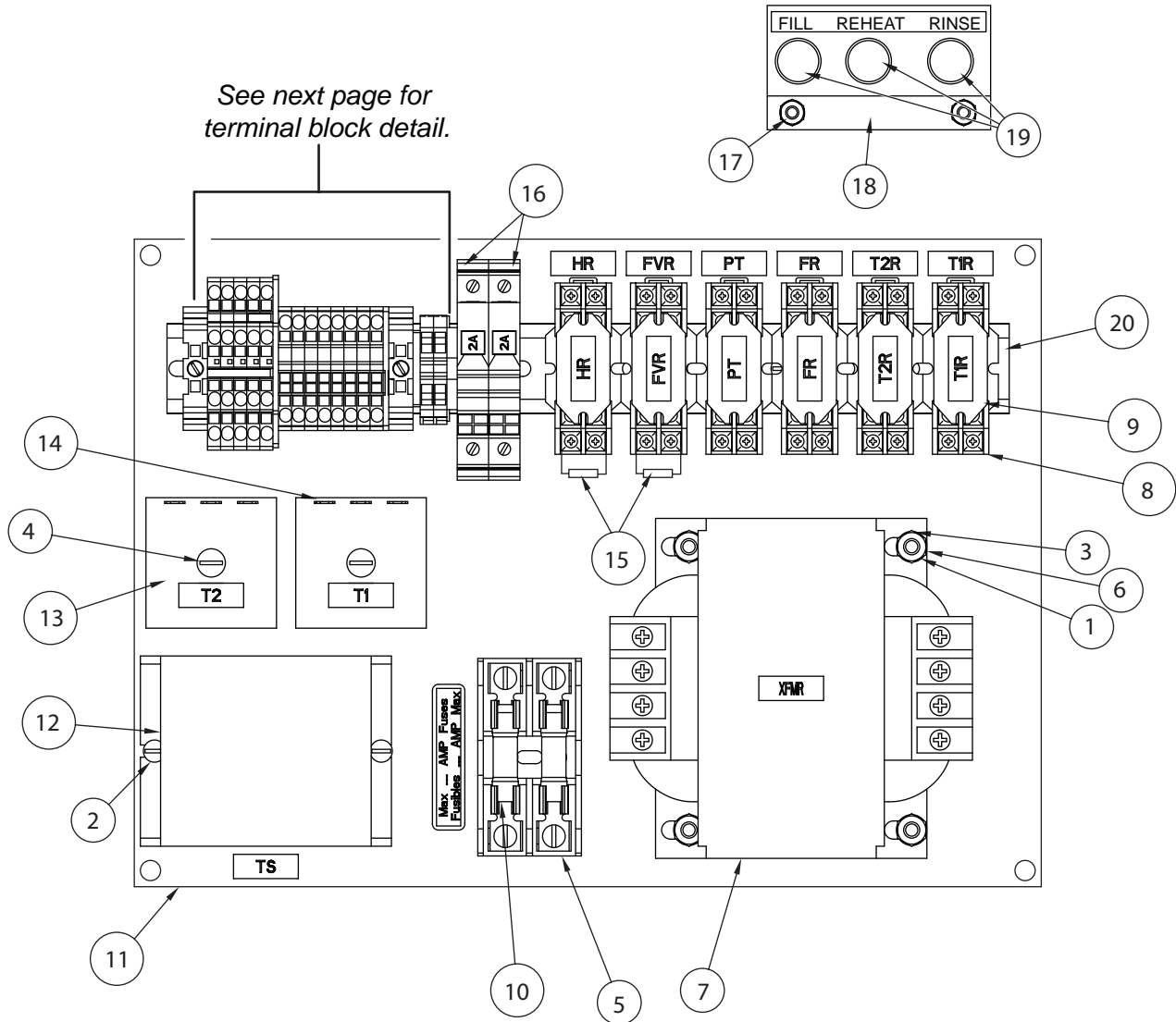

Prior to S/N J11022850

(Right to Left Direction Shown)

(For left to right direction, flip inner panel to place transformer to the left)



Item No.	Part No.	Description	Qty.
1	100003	HEX PLAIN NUT, 1/4-20 SST	4
2	100095	SCREW, ROUND HD., 10-32 X 3/8" SST	9
3	100735	BOLT, HEX HD., 1/4-20 X 5/8" SST	8
4	106396	SCREW, TRUSS HD., 10-32 X 3/8" SST	2
5	106402	BLOCK, FUSE 2 POLE	1
6	106482	WASHER, LOCK, 1/4" SPLIT SST	12
7	107091	TRANSFORMER, 500VA 240/480, 230/460:120	1
--	111521	TRANSFORMER, 250VA 575:120VAC	1
8	111036	SOCKET, RELAY 2 POLE	6
9	111068	RELAY, 2-POLE 10A, 120VAC	6
10	111823	FUSE, ATDR 6A	2
11	333307	INNER PANEL, CONTROL CABINET HRU W/XFMR	1
12	114655	TEMPERATURE CONTROL MODULE, HRU	1
13	114662	TIMER, FIXED 30 SECOND 120VAC	1
14	114661	TIMER, FIXED 15 SECOND 120VAC	1
15	114666	RESISTOR, 10Ω 2W	2
16	114862	CIRCUIT BREAKER, 2A	2
17	107966	HEX GRIP NUT, 10-32 W/NYLON INSERT SST	2
18	333536	BRACKET, LIGHTS HRU CONTROL CABINET	1
19	106364	LIGHT, INDICATOR	3
20	113769	DIN RAIL 35MM X 15MM X 13" LG.	A/R
NS	333306	COVER, CONTROL CABINET HRU W/XFRM	1
NS	333305	CONTROL CABINET WELDMENT, HRU W/XFRM	1

Control Cabinet Terminal Block - Beginning with S/N J11022850 and above

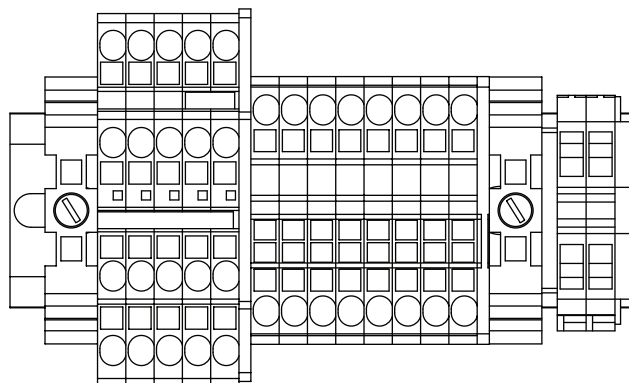
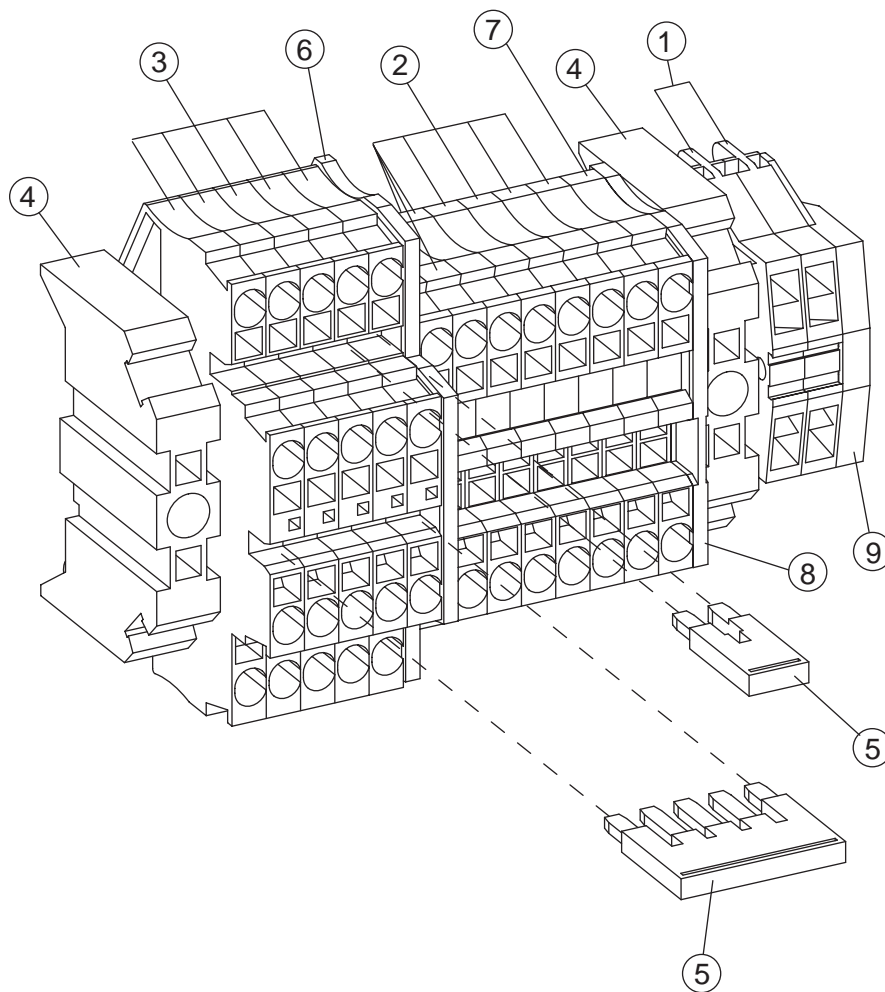

Item No.	Part No.	Description	Qty.
1	114520	TERMINAL, SINGLE MZB 1.5-NS35	2
2	114512	TERMINAL, SINGLE, ST 2.5 (GRAY)	7
3	114517	TERMINAL, DOUBLE STTB 2.5	5
4	114519	END BLOCK, E/NS 35N	2
5	114522	BUS BAR 10-POLE (CUT POLES TO FIT)	2
6	114518	END COVER, DOUBLE TERMINAL, D-STTB 2.5	1
7	114515	TERMINAL, SINGLE GROUND, ST 2.5 PE (GREEN)	1
8	114516	END COVER, SINGLE TERMINAL D-ST 2.5	1
9	114521	END COVER, SINGLE TERMINAL D-MZB 1.5 NS35	1

HRU Electric Booster Assembly

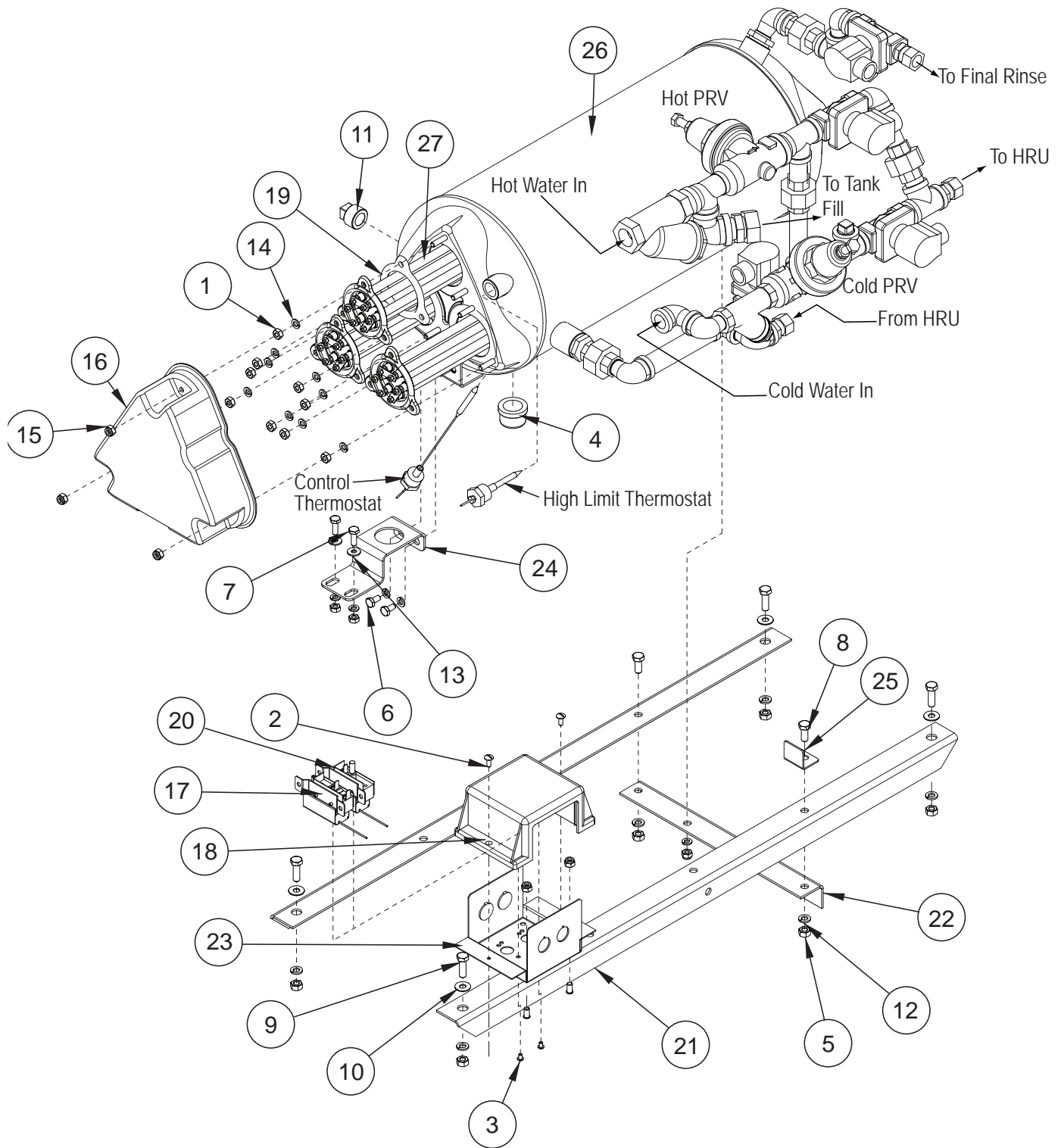

Item No.	Part No.	Description	Qty.
1	100003	HEX PLAIN NUT 1/4-20 SST	11
2	100097	SCREW, TRUSS HD. 10-32 X 1/2" SST	2
3	100100	SCREW, ROUND HD., 8-32 X 1/4" SST	2
4	100113	CAP, 3/4" NPT SST	1
5	100154	HEX PLAIN NUT, 5/16-18 SST	6
6	100734	BOLT, HEX HD., 1/4-20 X 1/2" SST	2
7	100736	BOLT, HEX HD., 1/4-20 X 3/4" SST	2
8	100739	BOLT, HEX HD., 5/16-18 X 3/4" SST	2
9	100740	BOLT, HEX HD., 5/16-18 X 1" SST	4
10	102376	WASHER, FLAT 5/16-18 SST	4
11	102505	PLUG, 3/4" NPT SQ. HD., BRASS	1
12	106013	WASHER, LOCK SPLIT 5/16" SST	6
13	106026	WASHER, FLAT 1/4" SST	2
14	106482	WASHER, LOCK SPLIT 1/4" SST	2
15	107967	HEX GRIP NUT, 1/4-20 SST W/NYLON	14
16	108576	COVER, BOOSTER HEATER	1
17	109069	THERMOSTAT, CONTROL	1
18	109682	COVER, THERMOSTAT BOX	1
19	109985	O-RING, BOOSTER HEATER ELEMENT	3
20	110561	THERMOSTAT, HIGH LIMIT	1
21	206668	ANGLE, ELECTRIC BOOSTER SUPPORT	1
22	206919	ANGLE, ELECTRIC BOOSTER SUPPORT, D3	1
23	314102	BOX, DUAL THERMOSTAT	1
24	328254	BRACKET, BOOSTER SUPPORT W/HOLE	1
25	330571	BRACKET, PIPING SUPPORT ELEC. BOOSTER	1
26	414331	TANK, BOOSTER	1
27	111232	ELEMENT, BOOSTER 10KW, 208/60/3	3

# HRU Electric Booster Piping

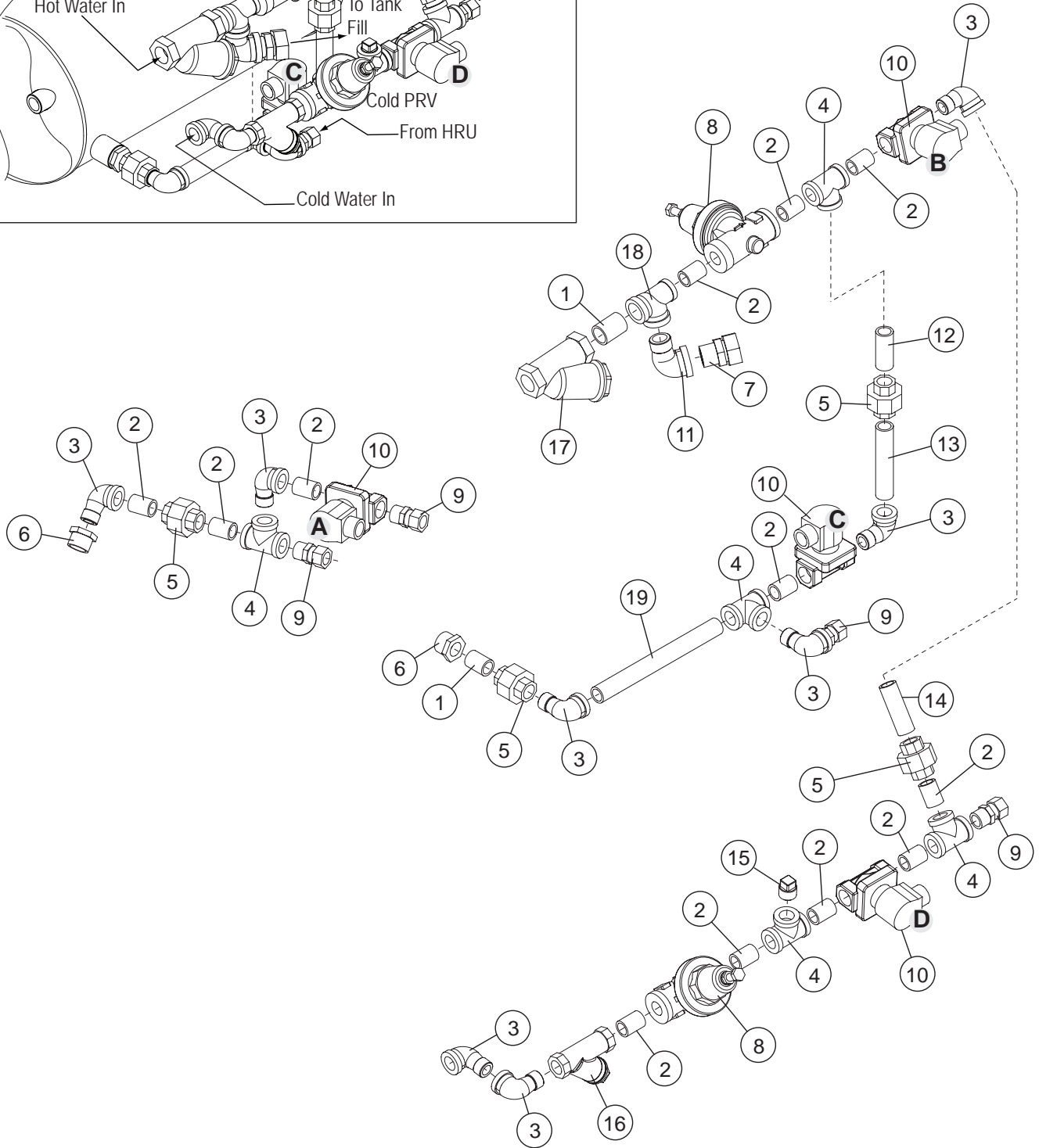
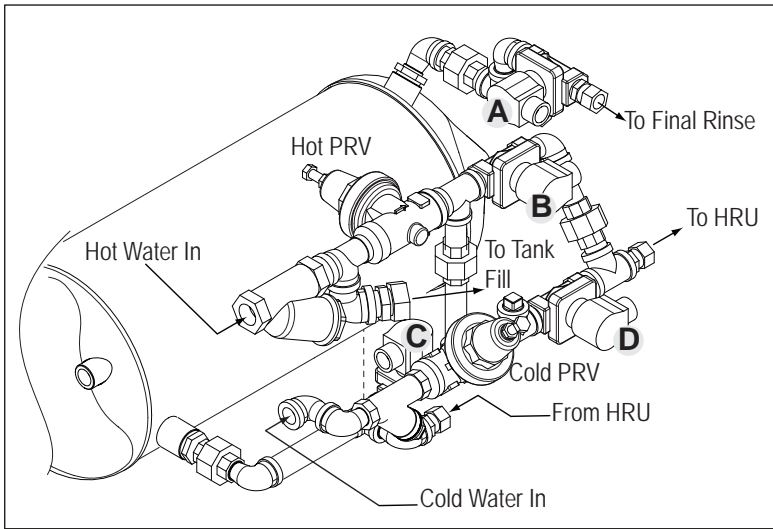

Item No.	Part No.	Description	Qty.
1	100184	NIPPLE, 3/4" NPT X CLOSE, BRASS	2
2	100209	NIPPLE, 1/2" NPT X CLOSE, BRASS	12
3	102438	ELBOW, STREET, 1/2" NPT X 90°, BRASS	8
4	102514	TEE, 1/2" NPT BRASS	5
5	102549	UNION, 1/2" NPT, BRASS	4
6	102392	BUSHING, REDUCING 3/4" NPT X 1/2" NPT, BRASS	2
7	109879	FITTING, COMP. 7/8" OD X 3/4" MPT, BRASS	1
8	108265	VALV, PRESSURE REGULATING, 1/2" NPT BRONZE	2
9	109925	FITTING, COMP., 5/8" OD X 1/2" MPT BRASS	4
10	111352	VALVE, SOLENOID 1/2" NPT 115V BRASS	4
---	109902	KIT, REPAIR, 1/2" SOLENOID VALVE	A/R
---	108516	COIL, SOLENOID VALVE 1/2" NPT 115V	A/R
11	102444	ELBOW STREET, 1/2" NPT 90°, BRASS	1
12	102492	NIPPLE, 1/2" NPT X 2" LG. BRASS	1
13	102570	NIPPLE, 1/2" NPT X 4" LG. BRASS	1
14	100206	NIPPLE, 1/2" NPT X 2-1/1" LG. BRASS	1
15	102504	PLUG, 1/2" NPT, SQ. HD. BRASS	1
16	104421	STRAINER, LINE, 1/2" NPT BRONZE	1
17	110768	STRAINER, LINE, 3/4" NPT BRONZE	1
18	102525	TEE, RED, 3/4" X 1/2" X 1/2" NPT BRONZE	1
19	102574	NIPPLE, 1/2" NPT X 5" LG. BRASS	1

HRU Steam Booster Assembly

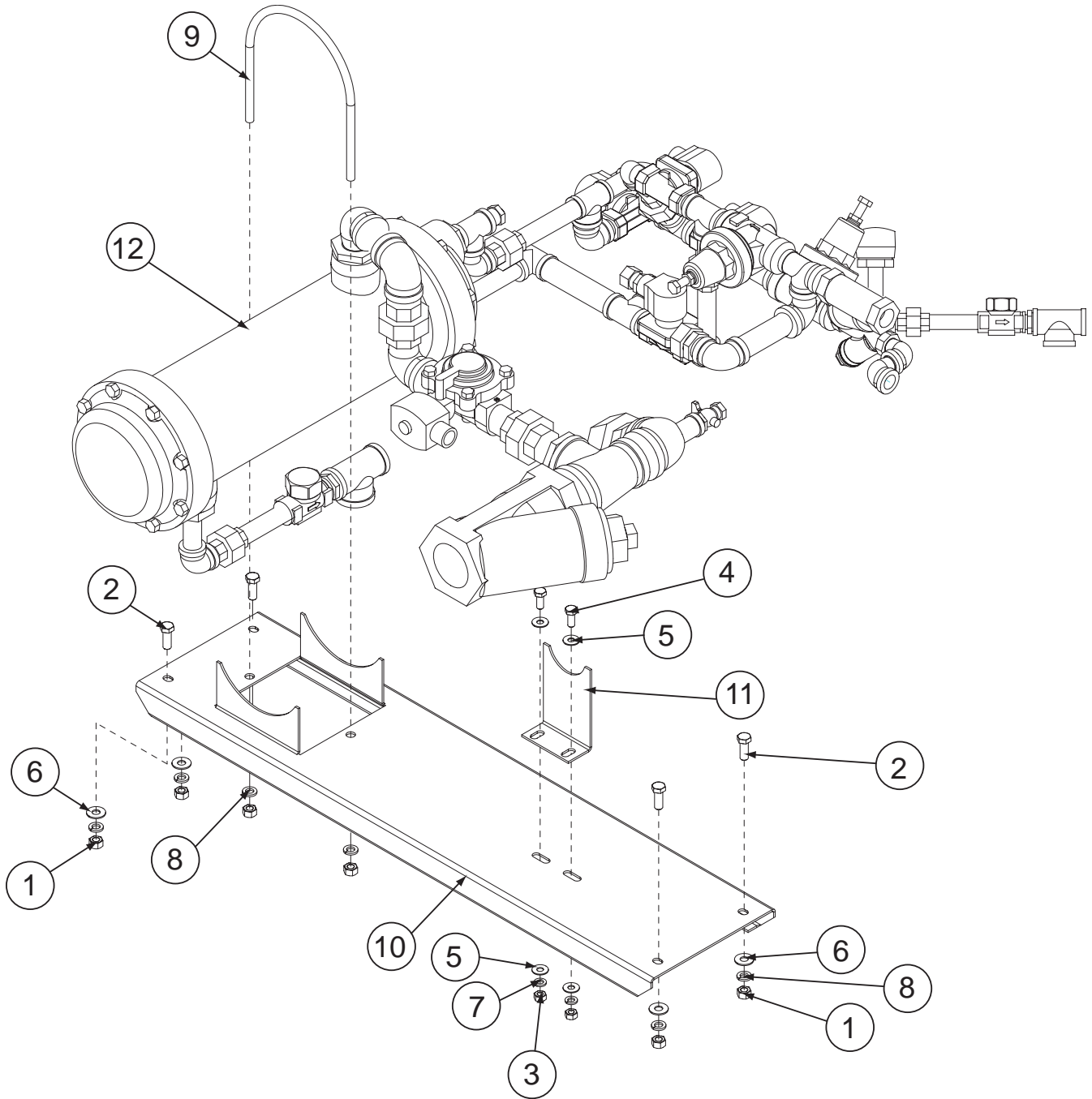



Item No.	Part No.	Description	Qty.
1	100140	HEX PLAIN NUT, 3/8-16 SST	6
2	100153	BOLT, HEX HD. 3/8-16 X 1" SST	4
3	100154	HEX PLAIN NUT, 5/16-18 SST	2
4	100739	BOLT, HEX HD., 5/16-18 X 3/4" SST	2
5	102376	WASHER, FLAT 5/16" SST	4
6	104618	WASHER, FLAT 3/8" SST	4
7	106013	WASHER, LOCK 5/16" SPLIT SST	2
8	106407	WASHER, LOCK 3/8" SPLIT SST	6
9	112334	U-BOLT, #180 BOOSTER	1
10	330244	BASE, DECK STEAM BOOSTER	1
11	330245	SUPPORT, STRAINER STEAM BOOSTER	1
12	601923	BOOSTER SUB ASSY, STEAM #120 RL	1

HRU Steam Booster Piping

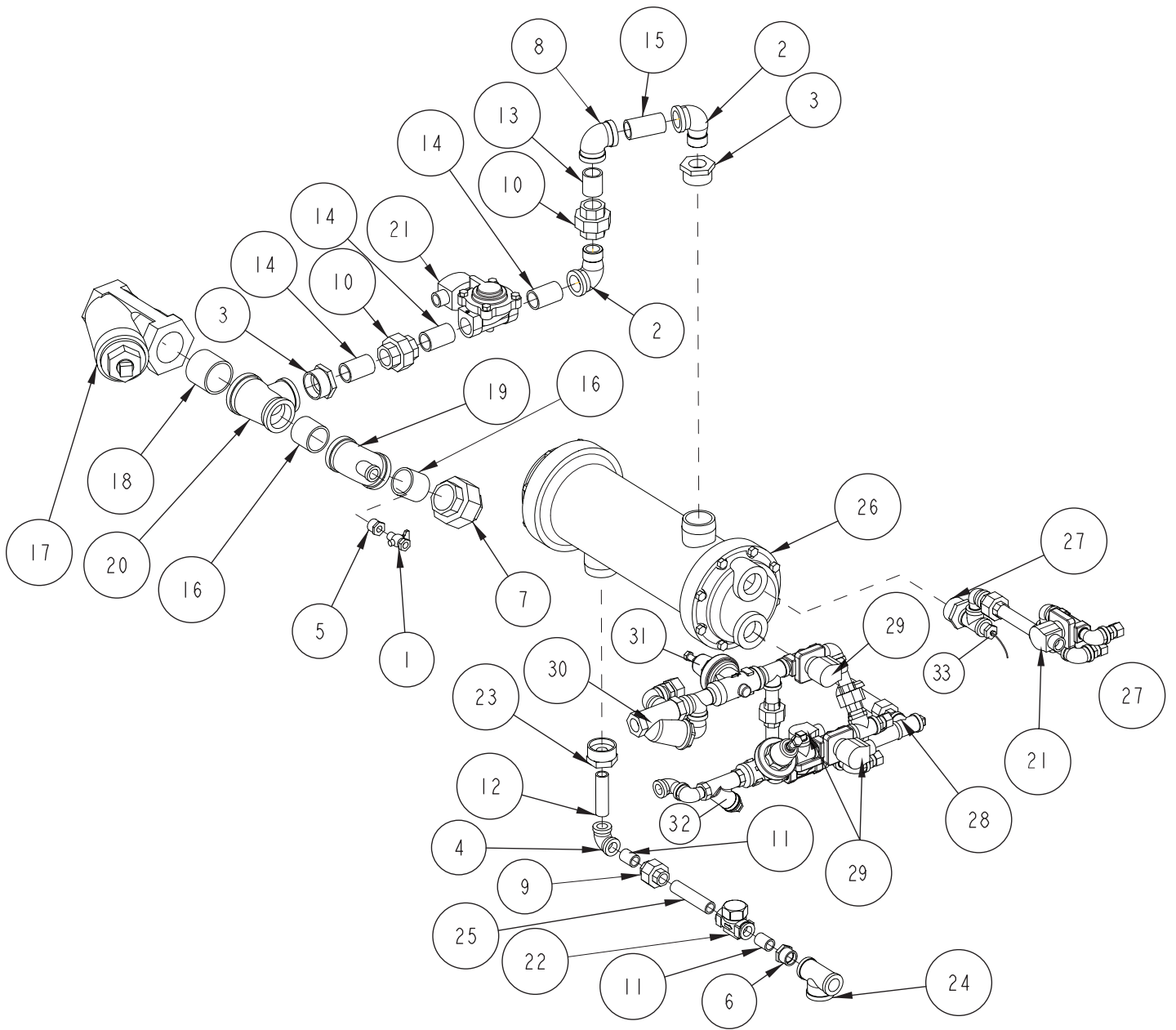

Item No.	Part No.	Description	Qty.
1	100123	PETCOCK, 1/4" FEMALE BRASS	1
2	100134	ELBOW, STREET, 1" NPT X 90° MI	2
3	100979	BUSHING, RED 1-1/2" NPT X 1" NPT BI	2
4	102288	ELBOW, 1/2" NPT X 90° MI	1
5	102402	BUSHING, RED. 3/4" NPT X 1/2" NPT BI	1
6	103465	BUSHING, RED. 3/4" NPT X 1/2" NPT BI	1
7	103586	UNION, 1/2" NPT MI	1
8	105733	ELBOW, 1" NPT, X 90° MI	1
9	105778	UNION 1/2" NPT MI	1
10	105780	UNION 1" NPT MI	2
11	105782	NIPPLE 1/2" NPT X CLOSE BI	2
12	105786	NIPPLE 1/2" NPT X 3" NPT LG. BI	1
13	105847	NIPPLE, 1" NPT X CLOSE BI	1
14	105850	NIPPLE, 1" NPT X 2" LG. BI	3
15	105851	NIPPLE, 1" NPT X 2-1/2" LG. BI	1
16	105881	NIPPLE, 1-1/2" NPT X CLOSE BI	2
17	106051	STRAINER, LINE 2" NPT BI	1
18	106607	NIPPLE, 2" NPT X CLOSE BI	1
19	107004	TEE, RED 1-1/2" X 1/2" X 1-1/2" MI	1
20	107657	TEE, RED, 2" X 1-1/2" X 1-1/2" NPT MI	1
21	110005	VALVE, 1" NPT STEAM	1
22	111380	STEAM TRAP, 1/2" NPT TDC	1
23	112349	BUSHING, RED. 1-1/2" NPT X 1/2" NPT BI	1
24	112359	TEE, RED. 3/4" X 3/4" X 1" NPT BI	1
25	112748	NIPPLE, 1/2" NPT X 3-3/4" LG. BI	1
26	114167	BOOSTER, THRUSH #120-1	1
27	601921	PIPING ASSY, STEAM BOOSTER, EXIT RL	1
28	601922	PIPING ASSY, STEAM BOOSTER, INLET RL	1
29	113352	VALVE, 1/2" NPT SOLENOID 120VAC	4
30	110768	STRAINER, LINE 3/4" NPT BRONZE	1
31	107550	VALVE, PRV 3/4" NPT BRONZE	1
32	110005	VALVE, STEAM 1" NPT SOLENOID 120VAC	1
33	109069	THERMOSTAT, CONTROL W/ CAPILLARY	1

***This Page  
Intentionally  
Left Blank***

***One Line Piping Diagram***  
***Operation Logic Diagram***  
***and***  
***Electrical Schematic***

***This Page  
Intentionally  
Left Blank***

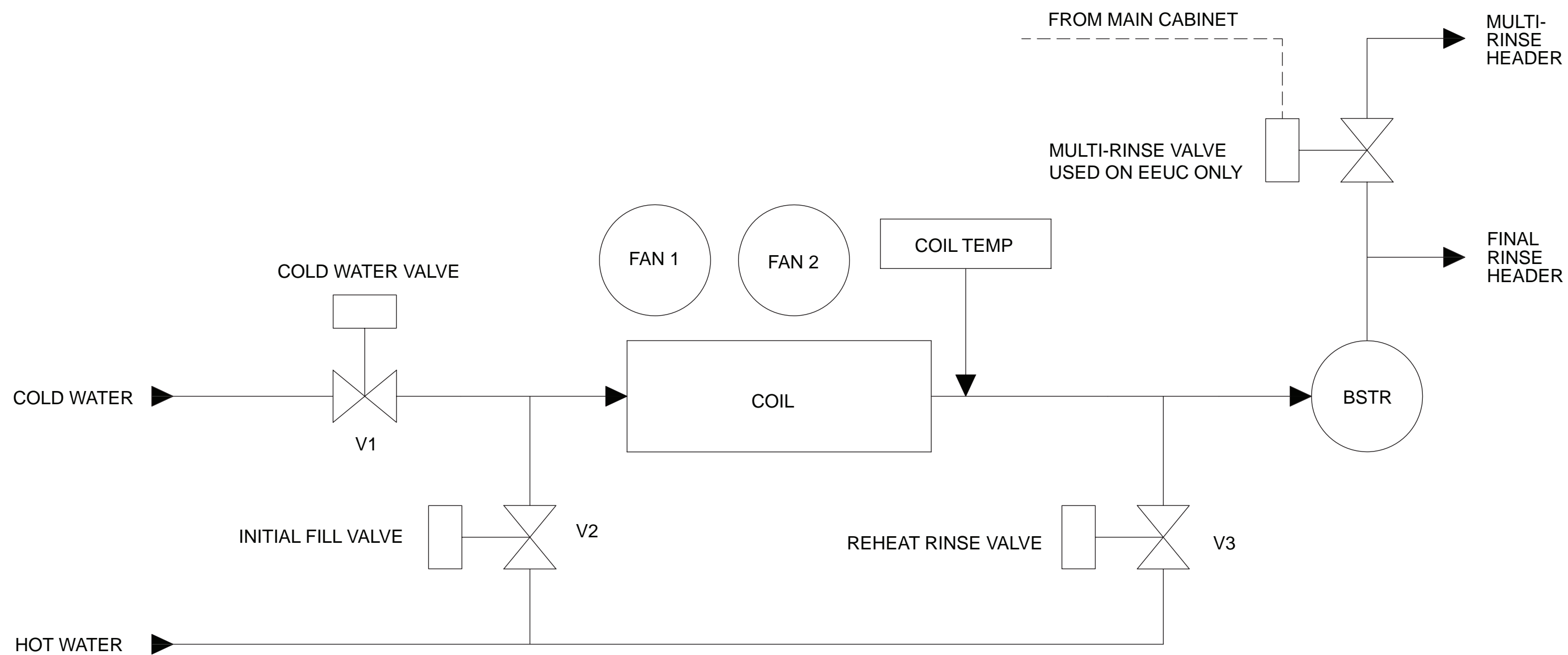

ONE LINE DIAGRAM FOR HEAT RECOVERY UNIT (HRU)  
 MODELS - EUCC4, EUCC8, EUCC6, EEUCC8, EEUCC6, EEUCC4

LOGIC FLOW DIAGRAM FOR HEAT RECOVERY UNIT  
 MODELS – EUCC8, EUCC6, EUCCW8, EUCCW6

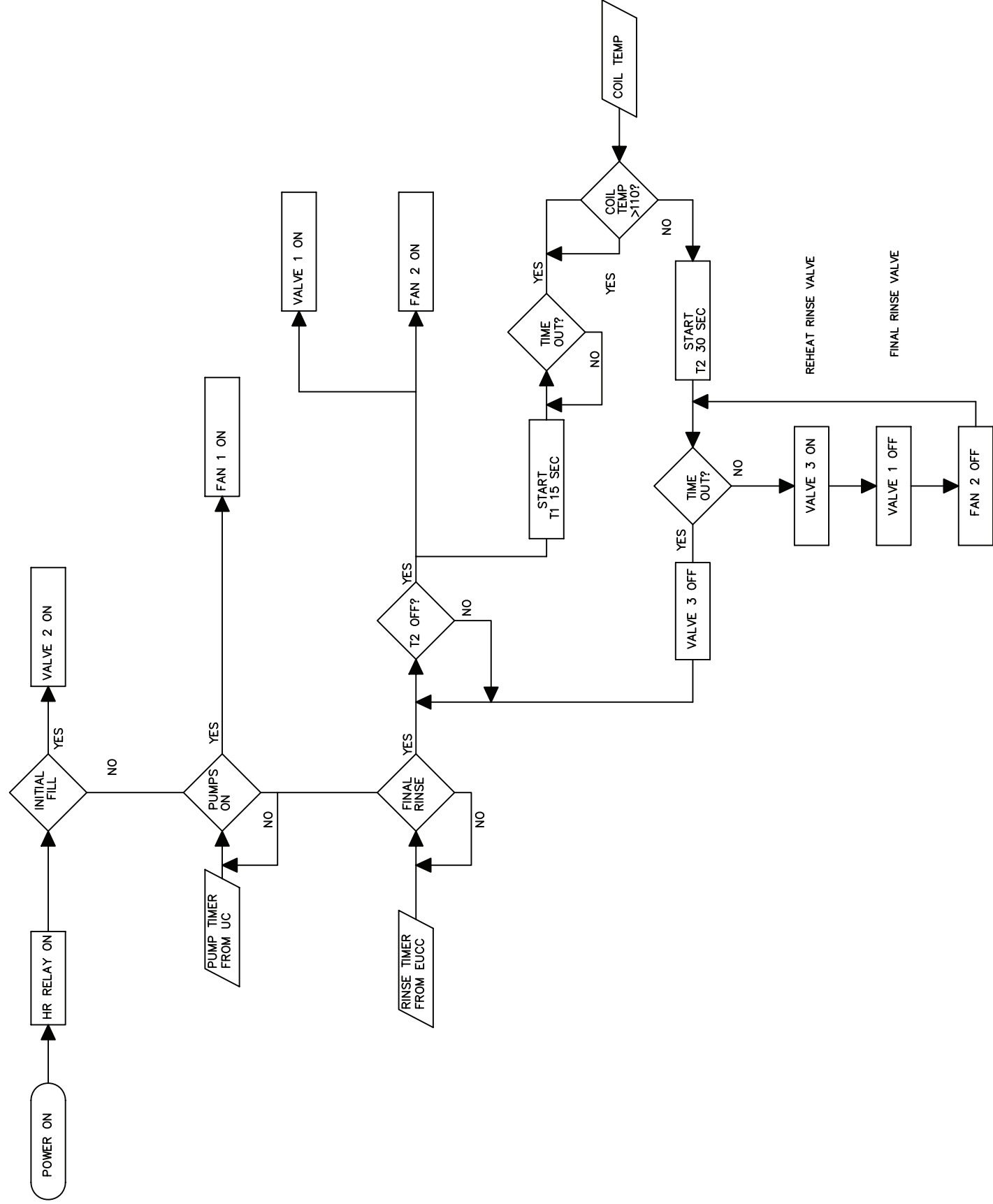

WIRING DIAGRAM FOR HEAT RECOVERY UNIT

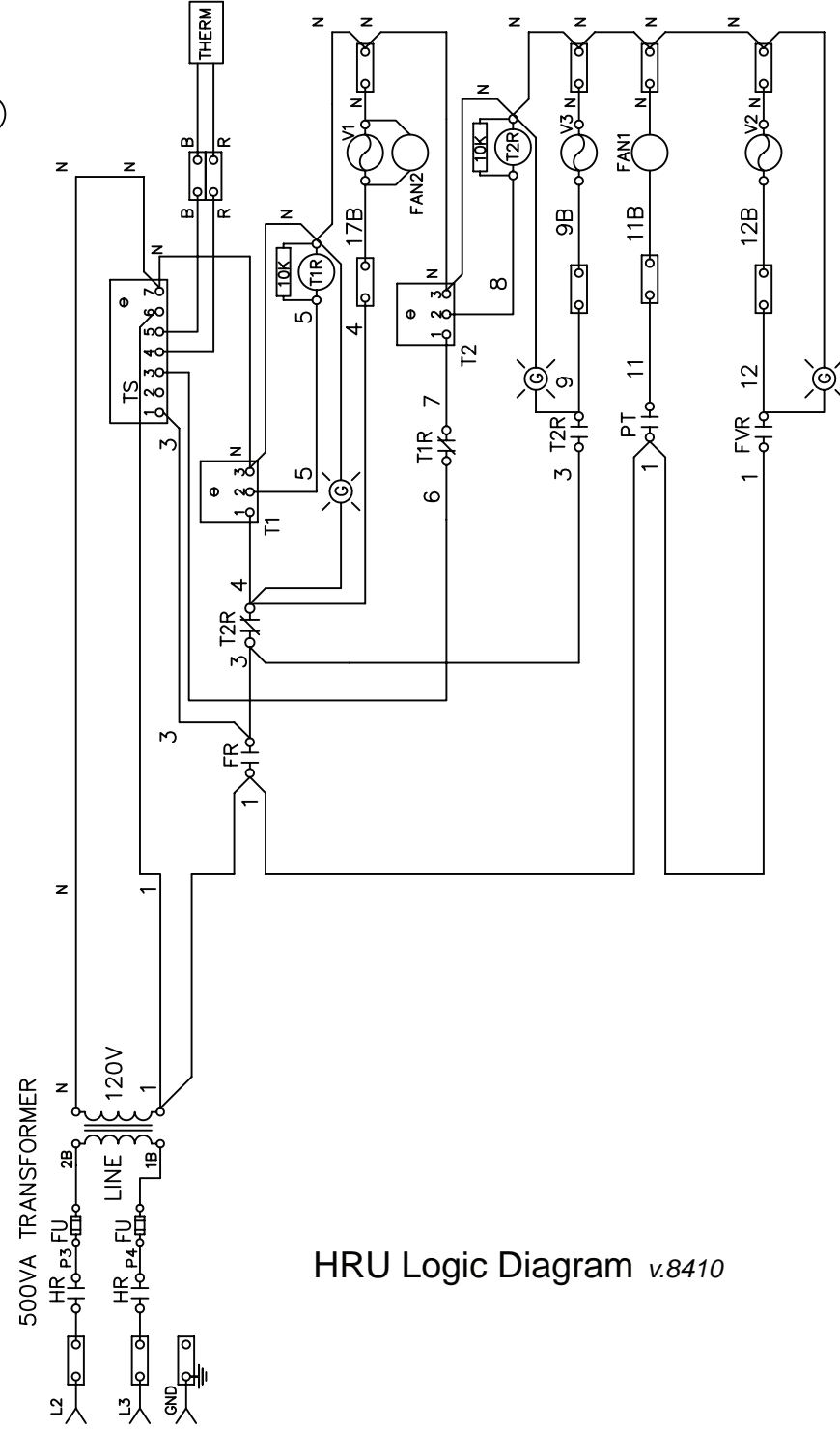
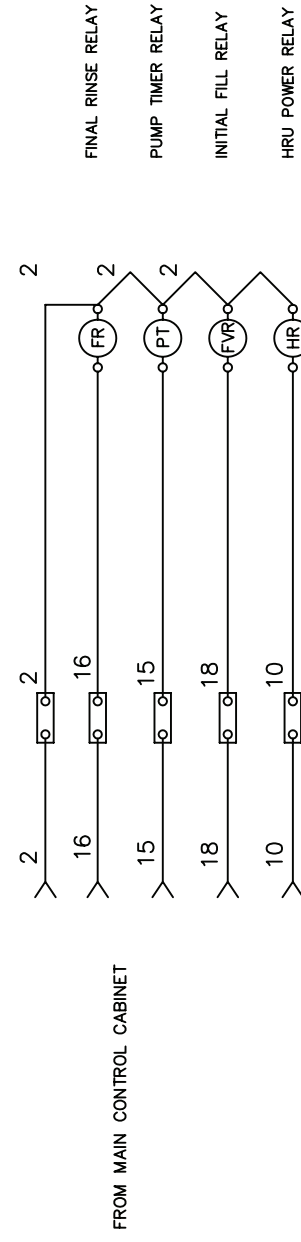

HRU Logic Diagram v.8410



WIRING DIAGRAM FOR HEAT RECOVERY UNIT

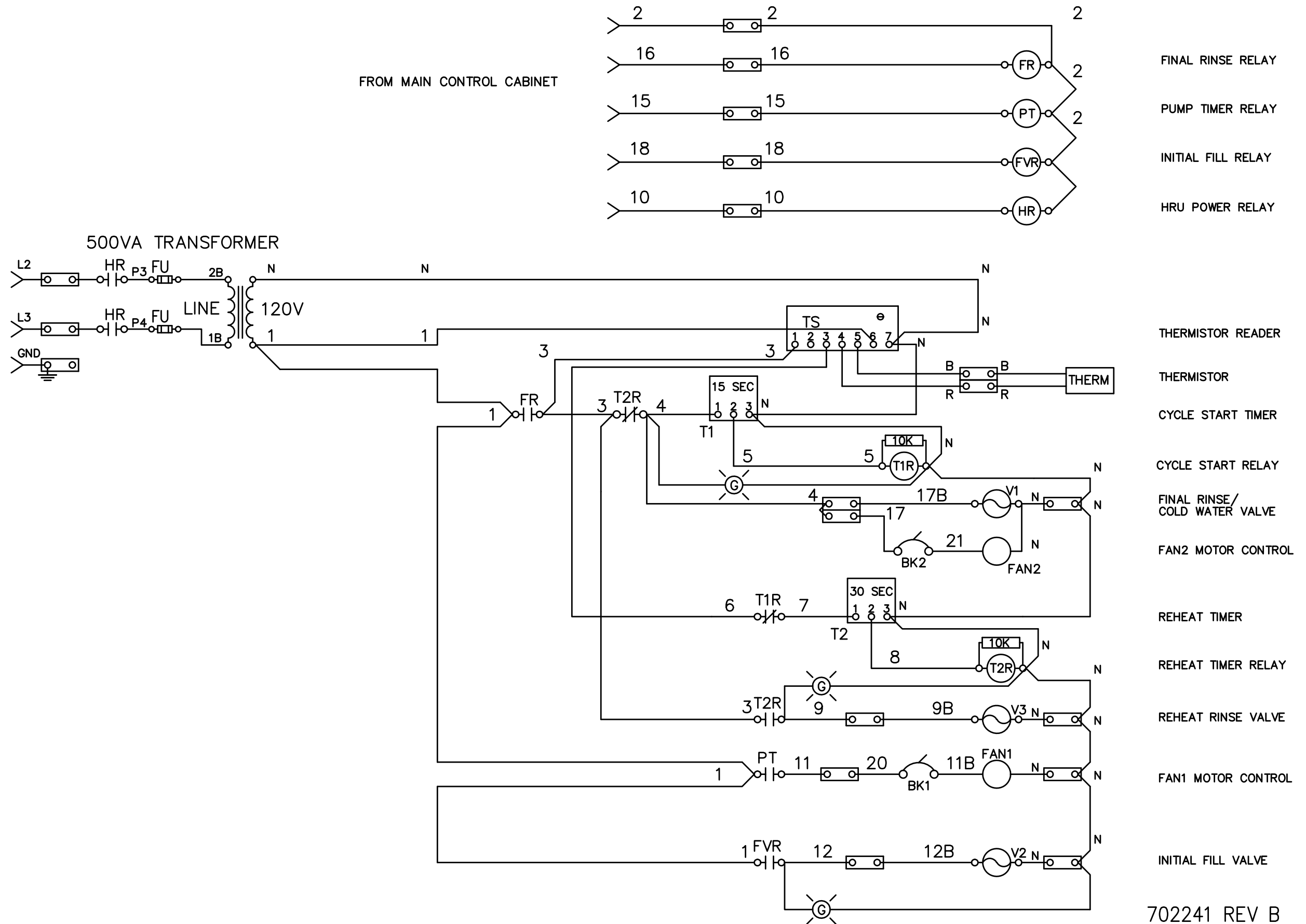

702241 REV B

***This Page  
Intentionally  
Left Blank***