



# SL60

## 2-3nm+ Solar Marine Light Installation & Service Manual

# SL60

## 2-3nm+ Solar Marine Light

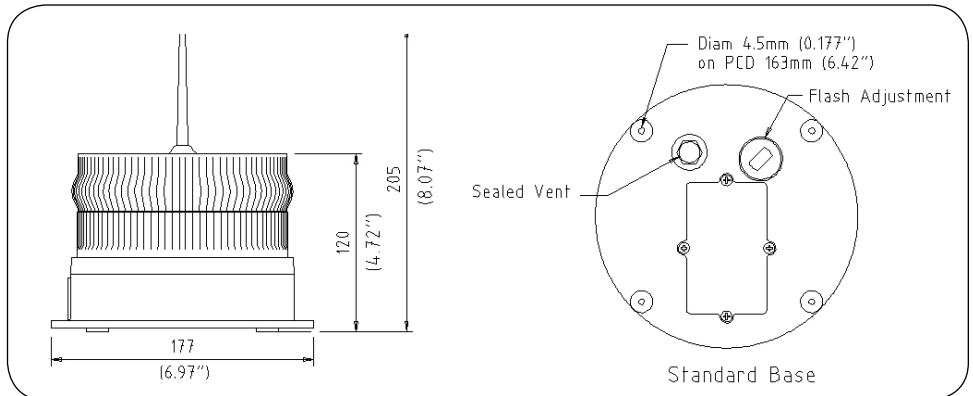
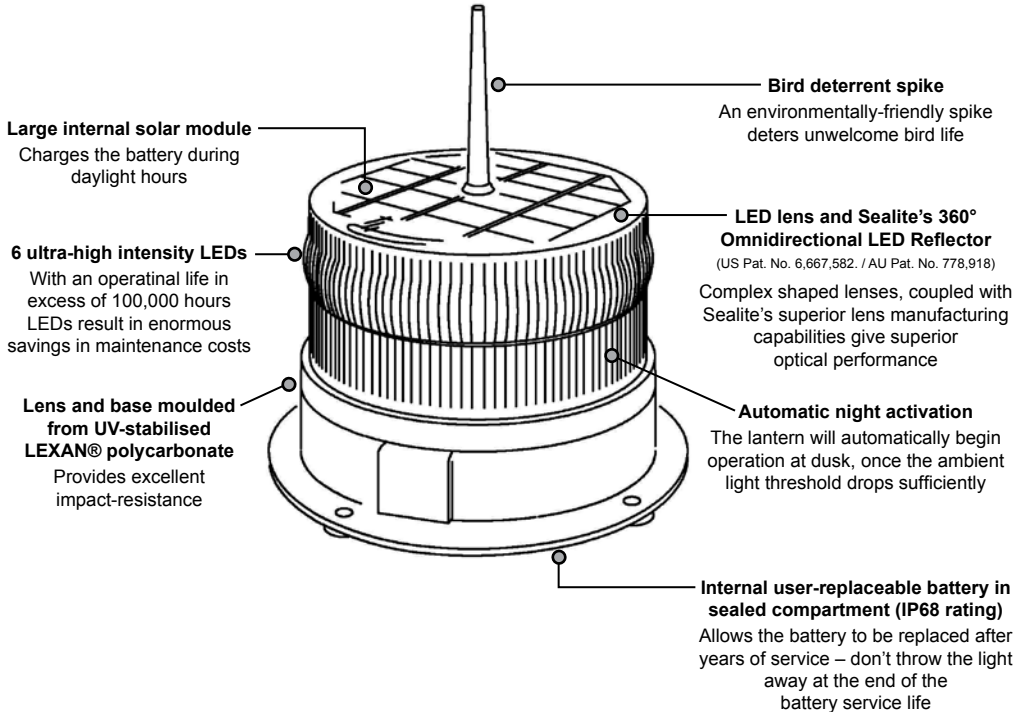

**Table of Contents**

**Introduction**.....Page 4

**Operating Principle** .....Page 4

**Technology**.....Page 4

**SL60 Model**.....Page 5

**Installation**.....Page 6

**Selecting an Intensity/Power Setting**.....Page 7

**Selecting a Flash Code** .....Page 7

**Flash Codes** .....Page 8

**Maintenance and Servicing** .....Page 13

**Troubleshooting** .....Page 14

**SL60 Optional Configurations**.....Page 15

**SL60 Accessories** .....Page 16

**Sealite LED Light Warranty** .....Page 18

Version No.	Description	Date	Approved
3.3	Re launch Catalogue	May 2009	K. Paton
3.4	Custom Manual	April 2010	K. Paton
3.5	Logo Update	May 2010	K. Paton
3.6	Warranty Update	July 2010	K. Paton
4.0	Update: Quality Logo	May 2011	J. Dore
4.1	Update: Spec Table	May 2012	J.Dore

## Introduction

**Congratulations! By choosing to purchase a Sealite lantern you have become the owner of one of the most advanced LED marine lanterns in the world.**

Sealite Pty Ltd has been manufacturing lanterns for over 25 years, and particular care has been taken to ensure your lantern gives years of service.

As a commitment to producing the highest quality products for our customers, Sealite has been independently certified as complying with the requirements of ISO9001:2008 quality management system.

Sealite lanterns comply with requirements of the US Coast Guard in 33 CFR part 66 for Private Aids To Navigation.

By taking a few moments to browse through this booklet, you will become familiar with the versatility of your lantern, and be able to maximise its operating function.

Please remember to complete the Sealite warranty registration card accompanying your lantern.

## Operating Principle

The solar module of the lantern converts sunlight to an electrical current that is used to charge the battery. The battery provides power to operate the lantern at night.

The flasher unit has very low current requirements. A microprocessor drives an array of ultra bright LED's through a DC/DC converter, which enables the LED's to operate within the manufacturer's specifications. The battery is protected from over-charging within the circuit to ensure maximum battery life.

On darkness, the microprocessor will initiate a program check and after approximately 1 minute begin flashing to the set code

## Technology

***Sealite is the world's fastest growing manufacturer of marine aids to navigation. We employ leading mechanical, optical, hardware & software engineers to create innovative products to service the needs of our customers worldwide, and offer the widest range of solar-powered LED lanterns in the marketplace.***

### Electronics

Sealite employs leading in-house electronic engineers in the design and development of software and related circuitry. All individual electronic components are sourced directly by Sealite procurement staff ensuring that only the highest quality components are used in our products.

### LED Technology

All marine lanterns use the latest advancements in LED (Light Emitting Diode) technology as a light source. The major advantage of LED's over traditional light sources is well established in that they typically have an operational life in excess of 100,000 hours, resulting in substantial savings to maintenance and servicing costs.

### Precision Construction

Commitment to investing in the design and construction of injection-moulded parts including optic lenses, light bases and a range of other components ensures that all Sealite products are of a consistent & superior quality.

### Optical Performance

Sealite manufactures a range of marine LED lenses moulded from multi-cavity dies. Complex shapes such as the SL70, BargeSafe™ and 16-segment multi-focus lenses are a testament to the company's superior in-house lens manufacturing capabilities and outstanding optical performance.

### Award-winning, Patented Technology

Several United States and Australian patent registrations are held on Sealite's range of innovative designs, with other regional patents pending in Canada, United Kingdom and Europe.

# SL60 Model

*The Sealite SL60 is the most popular and versatile 2-3nm+ solar marine light available. Made from tough, durable polycarbonate and using the latest high-intensity LEDs, no expense has been spared in the design and development of this lantern. Installation takes just minutes, and a permanent ON/OFF switch allows for easy storage.*

*The unit is ideal for navigation, hazard lighting, aquaculture, perimeter lighting and a range of other applications.*

## SPECIFICATIONS •

### Light Characteristics

Light Source	6 ultra-high intensity LEDs
Available Colours	Red, Green, White, Yellow, Blue
Maximum Available Intensity (cd)†	Red - 11.4 Green - 20.0 White - 26.0 Yellow - 10.0
Visible Range (nm)	2-3+
Horizontal Output (degrees)	360
Vertical Divergence (degrees)	9
Reflector Type	Omnidirectional 360° LED Reflector (US Pat. No. 6,667,582. AU Pat. No. 778,918)
Available Flash Characteristics	Up to 256 IALA recommended (user adjustable)
Intensity Adjustments	Adjustable in 25% increments
LED Life Expectancy (hours)	>100,000

### Electrical Characteristics

Current Draw (mA)	Refer to Sealite Power Calculator
Circuit Protection	Integrated
Nominal Voltage (v)	3.6
Autonomy (days)	>20 (14 hour darkness, 12.5% duty cycle)
Temperature Range	-40 to 80°C

### Solar Characteristics

Solar Module Type	Multicrystalline
Output (watts)	1.4
Solar Module Efficiency (%)	14
Charging Regulation	Microprocessor controlled

### Power Supply

Battery Type	High grade NiMH - Environmentally friendly
Battery Capacity (Ah)	4
Nominal Voltage (v)	3.6
Battery Service Life	Average 5 years

### Physical Characteristics

Body Material	LEXAN® Polycarbonate - UV-stabilised
Lens Material	LEXAN® Polycarbonate - UV-stabilised
Lens Diameter (mm/inches)	150 / 5 <sup>7</sup> / <sub>8</sub>
Lens Design	External optics with interior flute design
Mounting	4 x 4.5mm mounting holes
Height (mm/inches)	205 / 8 <sup>1</sup> / <sub>8</sub>
Width (mm/inches)	177 / 7
Mass (kg/lbs)	0.9 / 2 <sup>1</sup> / <sub>8</sub> (SL60-LB 1 / 2 <sup>1</sup> / <sub>4</sub> . SL60/8Ah 1 / 2 <sup>1</sup> / <sub>4</sub> . SL60-LB/Ah 1.1 / 2 <sup>1</sup> / <sub>2</sub> . SL60-LB/16Ah 1.5 / 3 <sup>1</sup> / <sub>3</sub> )
Product Life Expectancy	Up to 12 years

### Certifications

CE	EN61000-6-3:1997. EN61000-6-1:1997
Quality Assurance	ISO9001:2008
Waterproof	IP68

### Intellectual Property

Patents	US Pat. No. 6,667,582. AU Pat. No. 778,918
Trademarks	SEALITE® is a registered trademark of Sealite Pty Ltd
Warranty *	3 years

### Options Available

- 8Ah battery
- 16Ah battery
- 200mm OD base
- 50mm pole mount adapter plate

• Specifications subject to change or variation without notice  
 \* Subject to standard terms and conditions  
 † Intensity setting subject to solar availability



## Installation

### Charging the Battery

*New lanterns should be left in the sun for 1-2 days to ensure battery is charged before placing in service. Please note, lantern will re-charge even when toggle switch is turned to 'OFF' position.*

### Preferred Installation Location

*For best lantern performance, ensure solar modules are not covered and are in clear view of the sun with no shadows.*

### Lantern Operation

Lantern is activated by ON/OFF Switch. Intensity and flash settings need to be set prior to activation.

1. Remove the marked flash adjustment bung from the base of the lantern and set internal toggle switch to 'ON'.
2. The power and range settings of the lantern are adjusted by setting the DIP switches inside the lantern. Your lantern is normally set to maximum range (see 'Selecting an Intensity/Power Setting' section of this manual).
3. Set rotary switches to the required flash code (see 'Selecting a Flash Code' section of this manual).
4. Replace flash adjustment bung.
5. A sealed vent on the base allows air transfer without moisture intake, and should not be disturbed.
6. To test place dark cover (towel or jacket) on top of light to activate sensor, light will come on.
7. Ensure that the unit is bolted to an even, flat surface.

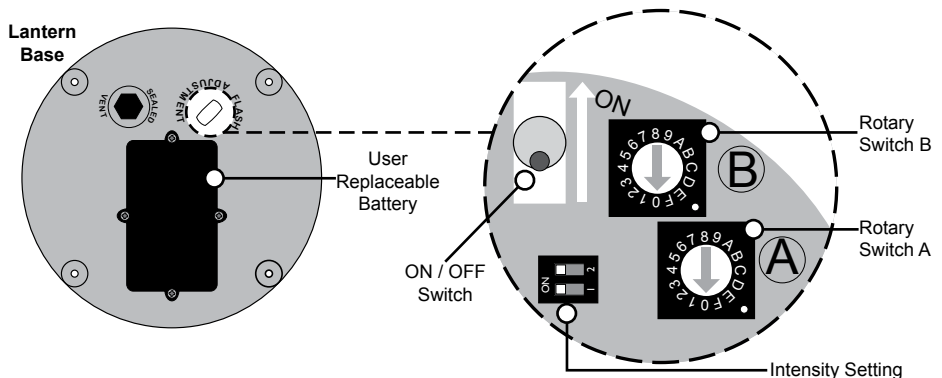

## Selecting an Intensity/Power Setting

Intensity/power settings on Sealite lanterns operate via DIP switches, located near the rotary switches on the flasher unit. The pulse settings may be used to reduce the power consumption and intensity of the lantern. Setting the lantern to 25% intensity will reduce the power consumption to 25% of the normal 100% setting and the range by 25%. This setting may be used to adjust the current draw of the light to local sunlight conditions.

The following diagrams indicate intensity/power settings:-

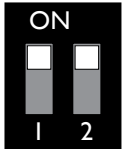

100%

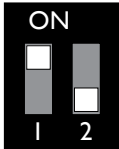

75%

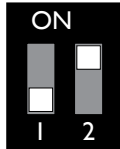

50%

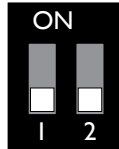

25%

Intensity Setting	Power mA / hour
100%	85mA
75%	64mA
50%	43mA
25%	22mA

## Power Consumption Calculator

Night Hours (use 13.7 if unknown)	Power mA/hour	Duty Cycle (e.g. 20% = 0.2)	Total power used per night (mA)
	X	X	=

Total power used per night (mAh)	Solar Panel Charge (mA)	Number of full sunlight hours required to break even (the amount of time it will take for the solar to replace what the light took out overnight)
/	176	=

If the number of Full Sunlight hours is greater than 2.5-3.0 hours, please consider reducing the intensity (Power) or reducing the Duty Cycle.

## Selecting a Flash Code - Rotary Switches A & B

All lanterns have 2 rotary switches marked A and B on the flasher unit. Turning the small arrows to the appropriate number or letter will set the code (see 'Flash Codes' section, of this manual). The unit may take up to one minute to activate a new flash code. A comprehensive list of available flash codes is listed on pages in the 'Flash Codes' section of this manual.

Example:

SWITCH	FLASH CODE	ON	OFF
A	B		
A	0	FL 3 S	0.3 2.7

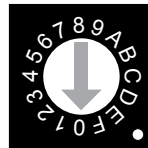

## Flash Codes

The Sealite SL60 may be set to any of 256 IALA recommended flash settings which are user-adjustable onsite without the need for external devices.

**SEALITE® code reference is listed by number of flashes**

**For the latest version of this document visit [www.sealite.com](http://www.sealite.com),  
or email [info@sealite.com](mailto:info@sealite.com)**

### Symbols

FL	Flash followed by number Eg. FL 1 S, one flash every second
F	Fixed
Q	Quick flash
VQ	Very quick flash
OC	Occulting; greater period on than off
ISO	Isophase; equal period on and off
LFL	Long flash long
MO	Morse code ( ) contains letter

For example, VQ (6) + LFL 10 S means 6 very quick flashes followed by a long flash, during a 10-second interval.

The amount of power your lantern draws through the night depends on the duty cycle, i.e. the amount of time on as a proportion to the timing cycle. For example, 0.5 seconds on and 4.5 seconds off equals a 10% duty cycle.

It is best to operate at the lowest duty cycle appropriate to the actual needs of the application.

### Recommended Rhythm for Flashing Light - IALA Regions A and B

MARK DESCRIPTION	RHYTHM
<b>Port Hand &amp; Starboard Marks:</b>	Any, other than Composite Group Flashing (2+1)
<b>Preferred Channel Starboard:</b>	Composite Group Flashing (2+1)
<b>Preferred Channel Port:</b>	Composite Group Flashing (2+1)
<b>North Cardinal Mark:</b>	Very quick or quick
<b>East Cardinal Mark:</b>	Very quick (3) every 5 seconds or quick (3) every 10 seconds
<b>South Cardinal Mark:</b>	Very quick (6) + long flash every 10 seconds or quick (6) + long flash every 15 seconds
<b>West Cardinal Mark:</b>	Very quick (9) every 10 seconds or quick (9) every 15 seconds
<b>Isolated Danger Mark:</b>	Group flashing (2)
<b>Safe Water Mark:</b>	Isophase, occulting, one long flash every 10 seconds or Morse Code "A"
<b>Special Marks:</b>	Any, other than those described for Cardinal, Isolated Danger or Safe Water Marks



SWITCH	FLASH CODE	ON	OFF
A	B		
0	0 F (Steady light)		
D	3 VQ 0.5 S	0.2	0.3
E	3 VQ 0.6 S	0.2	0.4
F	3 VQ 0.6 S	0.3	0.3
7	3 Q 1 S	0.2	0.8
8	3 Q 1 S	0.3	0.7
9	3 Q 1 S	0.4	0.6
A	3 Q 1 S	0.5	0.5
8	4 Q 1 S	0.8	0.2
B	3 Q 1.2 S	0.3	0.9
9	4 Q 1.2 S	0.5	0.7
C	3 Q 1.2 S	0.6	0.6
F	4 FL 1.5 S	0.2	1.3
1	0 FL 1.5 S	0.3	1.2
0	5 FL 1.5 S	0.4	1.1
0	4 FL 1.5 S	0.5	1.0
2	0 FL 2 S	0.2	1.8
3	0 FL 2 S	0.3	1.7
4	0 FL 2 S	0.4	1.6
5	0 FL 2 S	0.5	1.5
6	0 FL 2 S	0.7	1.3
7	0 FL 2 S	0.8	1.2
1	2 ISO 2 S	1.0	1.0
8	0 FL 2.5 S	0.3	2.2
9	0 FL 2.5 S	0.5	2.0
D	6 FL 2.5 S	1.0	1.5
1	5 FL 3 S	0.2	2.8
A	0 FL 3 S	0.3	2.7
2	5 FL 3 S	0.4	2.6
B	0 FL 3 S	0.5	2.5
3	5 FL 3 S	0.6	2.4
C	0 FL 3 S	0.7	2.3
D	0 FL 3 S	1.0	2.0
2	2 ISO 3 S	1.5	1.5
5	4 OC 3 S	2.0	1.0
E	2 OC 3 S	2.5	0.5
4	6 OC 3.5 S	2.5	1.0
4	5 FL 4 S	0.2	3.8
5	5 FL 4 S	0.3	3.7
E	0 FL 4 S	0.4	3.6
F	0 FL 4 S	0.5	3.5
6	5 FL 4 S	0.6	3.4
0	1 FL 4 S	0.8	3.2
1	1 FL 4 S	1.0	3.0
2	1 FL 4 S	1.5	2.5
3	2 ISO 4 S	2.0	2.0
3	6 OC 4 S	2.5	1.5
F	2 OC 4 S	3.0	1.0
3	1 FL 4.3 S	1.3	3.0
8	5 FL 5 S	0.2	4.8
4	1 FL 5 S	0.3	4.7
5	1 FL 5 S	0.5	4.5
9	5 FL 5 S	0.9	4.1
6	1 FL 5 S	1.0	4.0

SWITCH	FLASH CODE	ON	OFF
A	B		
7	1 FL 5 S	1.5	3.5
4	2 ISO 5 S	2.5	2.5
8	2 LFL 5 S	2.0	3.0
0	3 OC 5 S	3.0	2.0
1	3 OC 5 S	4.0	1.0
2	3 OC 5 S	4.5	0.5
C	6 FL 6 S	0.2	5.8
B	5 FL 6 S	0.3	5.7
C	5 FL 6 S	0.4	5.6
8	1 FL 6 S	0.5	5.5
9	1 FL 6 S	0.6	5.4
A	1 FL 6 S	1.0	5.0
7	5 FL 6 S	1.2	4.8
B	1 FL 6 S	1.5	4.5
5	2 ISO 6 S	3.0	3.0
9	2 LFL 6 S	2.0	4.0
6	4 OC 6 S	4.0	2.0
3	3 OC 6 S	4.5	1.5
4	3 OC 6 S	5.0	1.0
A	4 FL 7 S	1.0	6.0
9	6 FL 7 S	2.0	5.0
5	6 OC 7 S	4.5	2.5
D	5 FL 7.5 S	0.5	7.0
C	1 FL 7.5 S	0.8	6.7
E	5 FL 8 S	0.5	7.5
B	4 FL 8 S	1.0	7.0
6	2 ISO 8 S	4.0	4.0
A	2 LFL 8 S	2.0	6.0
6	6 OC 8 S	5.0	3.0
B	2 LFL 8 S	3.0	5.0
F	5 FL 9 S	0.9	8.1
C	4 FL 9 S	1.0	8.0
7	6 OC 9 S	6.0	3.0
0	6 FL 10 S	0.2	9.8
1	6 FL 10 S	0.3	9.7
D	1 FL 10 S	0.5	9.5
2	6 FL 10 S	0.8	9.2
E	1 FL 10 S	1.0	9.0
1	4 FL 10 S	1.5	8.5
C	2 LFL 10 S	2.0	8.0
D	2 LFL 10 S	3.0	7.0
7	2 ISO 10 S	5.0	5.0
2	4 LFL 10 S	4.0	6.0
8	6 OC 10 S	6.0	4.0
5	3 OC 10 S	7.0	3.0
6	3 OC 10 S	7.5	2.5
F	1 FL 12 S	1.2	10.8
D	4 FL 12 S	2.5	9.5
3	4 LFL 12 S	2.0	10.0
0	2 FL 15 S	1.0	14.0
4	4 LFL 15 S	4.0	11.0
7	4 OC 15 S	10	5.0
A	6 LFL 20 S	2.0	18.0
E	4 FL 26 S	1.0	25.0

SWITCH	FLASH CODE	ON	OFF	ON	OFF
<b>A</b>	<b>B</b>				
0	A FL (2) 4 S	0.5	1.0	0.5	2.0
E	B VQ (2) 4 S	0.2	1.0	0.2	2.6
1	A FL (2) 4.5 S	0.3	1.0	0.3	2.9
2	A FL (2) 4.5 S	0.4	1.0	0.4	2.7
3	A FL (2) 4.5 S	0.5	1.0	0.5	2.5
F	9 FL (2) 5 S	0.2	0.8	0.2	3.8
2	C FL (2) 5 S	0.2	1.2	0.2	3.4
4	A FL (2) 5 S	0.4	0.6	0.4	3.6
0	7 FL (2) 5 S	0.5	1.0	0.5	3.0
1	7 FL (2) 5 S	1.0	1.0	1.0	2.0
9	B Q (2) 5 S	0.3	0.7	0.3	3.7
2	9 Q (2) 5 S	0.5	0.5	0.5	3.5
5	A FL (2) 5.5 S	0.4	1.4	0.4	3.3
7	8 FL (2) 6 S	0.3	0.6	1.0	4.1
A	A FL (2) 6 S	0.3	0.9	0.3	4.5
6	A FL (2) 6 S	0.3	1.0	0.3	4.4
7	A FL (2) 6 S	0.4	1.0	0.4	4.2
9	9 FL (2) 6 S	0.5	1.0	0.5	4.0
2	8 FL (2) 6 S	0.8	1.2	0.8	3.2
3	7 FL (2) 6 S	1.0	1.0	1.0	3.0
3	9 Q (2) 6 S	0.3	0.7	0.3	4.7
A	9 FL (2) 7 S	1.0	1.0	1.0	4.0
7	B FL (2) 8 S	0.4	0.6	2.0	5.0
8	A FL (2) 8 S	0.4	1.0	0.4	6.2
4	7 FL (2) 8 S	0.5	1.0	0.5	6.0
8	8 FL (2) 8 S	0.8	1.2	2.4	3.6
5	7 FL (2) 8 S	1.0	1.0	1.0	5.0
4	C OC (2) 8 S	3.0	2.0	1.0	2.0
5	C OC (2) 8 S	5.0	1.0	1.0	1.0
F	B VQ (2) 8 S	0.2	1.0	0.2	6.6
9	A FL (2) 10 S	0.4	1.6	0.4	7.6
6	7 FL (2) 10 S	0.5	1.0	0.5	8.0
7	7 FL (2) 10 S	0.5	1.5	0.5	7.5
6	9 FL (2) 10 S	0.5	2.0	0.5	7.0
8	7 FL (2) 10 S	0.8	1.2	0.8	7.2
B	9 FL (2) 10 S	1.0	1.0	1.0	7.0
9	7 FL (2) 10 S	1.0	1.5	1.0	6.5
4	9 Q (2) 10 S	0.6	0.4	0.6	8.4
B	A FL (2) 12 S	0.4	1.0	0.4	10.2
C	9 FL (2) 12 S	0.5	1.0	0.5	10.0
D	9 FL (2) 12 S	1.5	2.0	1.5	7.0
A	8 FL (2) 15 S	0.5	1.5	2.0	11.0
A	7 FL (2) 15 S	1.0	2.0	1.0	11.0
8	B Q (2) 15 S	0.2	0.8	0.2	13.8
C	A FL (2) 20 S	1.0	3.0	1.0	15.0
D	A FL (2) 25 S	1.0	1.0	1.0	22.0

SWITCH	FLASH CODE	ON	OFF	ON	OFF	ON	OFF
<b>A</b>	<b>B</b>						
7	9 Q (3) 5 S	0.5	0.5	0.5	0.5	0.5	2.5
5	9 VQ (3) 5 S	0.2	0.3	0.2	0.3	0.2	3.8
0	C VQ (3) 5 S	0.3	0.2	0.3	0.2	0.3	3.7
E	9 VQ (3) 5 S	0.3	0.3	0.3	0.3	0.3	3.5
3	C FL (3) 6 S	0.5	1.0	0.5	1.0	0.5	2.5
2	B FL (2+1) 6 S	0.3	0.4	0.3	1.2	0.3	3.5

SWITCH	FLASH CODE	ON	OFF	ON	OFF	ON	OFF	
A	B							
A	B	Q (3) 6 S	0.3	0.7	0.3	0.7	0.3	3.7
F	A	FL (3) 8 S	0.5	1.0	0.5	1.0	0.5	4.5
0	B	FL (3) 9 S	0.3	1.0	0.3	1.0	0.3	6.1
B	7	FL (3) 9 S	0.8	1.2	0.8	1.2	0.8	4.2
B	8	FL (3) 10 S	0.3	0.7	0.3	0.7	0.9	7.1
C	8	FL (3) 10 S	0.4	0.6	0.4	0.6	1.2	6.8
C	B	FL (3) 10 S	0.5	0.5	0.5	0.5	0.5	7.5
C	7	FL (3) 10 S	0.5	1.5	0.5	1.5	0.5	5.5
D	B	FL (3) 10 S	0.6	0.6	0.6	0.6	0.6	7.0
D	7	FL (3) 10 S	1.0	1.0	1.0	1.0	1.0	5.0
3	8	FL (2+1) 10 S	0.5	0.7	0.5	2.1	0.5	5.7
8	9	OC (3) 10 S	5.0	1.0	1.0	1.0	1.0	1.0
B	B	Q (3) 10 S	0.3	0.7	0.3	0.7	0.3	7.7
D	8	FL (2 + 1) 10 S	0.5	0.5	0.5	0.5	1.5	6.5
1	B	FL (3) 12 S	0.5	1.5	0.5	1.5	0.5	7.5
E	A	FL (3) 12 S	0.5	2.0	0.5	2.0	0.5	6.5
E	7	FL (3) 12 S	0.8	1.2	0.8	1.2	0.8	7.2
B	6	FL (3) 12 S	1.0	1.0	1.0	3.0	1.0	5.0
4	8	FL (2+1) 12 S	0.8	1.2	0.8	2.4	0.8	6.0
5	8	FL (2+1) 12 S	1.0	1.0	1.0	4.0	1.0	4.0
1	8	FL (2+1) 13.5 S	1.0	1.0	1.0	4.0	1.0	5.5
F	7	FL (3) 15 S	0.3	1.7	0.3	1.7	0.3	10.7
9	D	FL (3) 15 S	0.4	1.0	0.4	1.0	0.4	11.8
0	8	FL (3) 15 S	0.5	1.5	0.5	1.5	0.5	10.5
F	8	FL (2+1) 15 S	0.6	0.3	0.6	0.3	1.4	11.8
0	9	FL (2+1) 15 S	0.7	0.5	0.7	0.5	1.9	10.7
1	9	FL (2+1) 15 S	0.7	0.7	0.7	0.7	2.1	10.1
6	8	FL (2+1) 15 S	1.0	2.0	1.0	5.0	1.0	5.0
1	C	VQ (3) 15 S	0.1	0.5	0.1	0.5	0.1	13.7
4	B	FL (3) 20 S	0.5	3.0	0.5	3.0	0.5	12.5
3	B	FL (3) 20 S	0.5	1.5	0.5	1.5	0.5	15.5
5	B	FL (3) 20 S	0.8	1.2	0.8	1.2	0.8	15.2
6	B	FL (3) 20 S	1.0	1.0	1.0	1.0	1.0	15.0

SWITCH	FLASH CODE	ON	OFF	ON	OFF	ON	OFF	ON	OFF
A	B								
B	F	VQ (4) 4 S	0.3	0.3	0.3	0.3	0.3	0.3	2.3
B	D	Q (4) 6 S	0.3	0.7	0.3	0.7	0.3	0.7	2.7
8	D	Q (4) 6 S	0.4	0.6	0.4	0.6	0.4	0.6	2.6
1	D	FL (4) 10 S	0.5	1.0	0.5	1.0	0.5	1.0	5.0
2	D	FL (4) 10 S	0.8	1.2	0.8	1.2	0.8	1.2	3.2
F	E	Q (4) 10 S	0.3	0.7	0.3	0.7	0.3	0.7	6.7
B	E	FL (4) 12 S	0.3	1.7	0.3	1.7	0.3	1.7	5.7
4	F	FL (4) 12 S	0.5	0.5	0.5	0.5	0.5	0.5	8.5
C	E	FL (4) 12 S	0.5	1.5	0.5	1.5	0.5	1.5	5.5
3	D	FL (4) 12 S	0.8	1.2	0.8	1.2	0.8	1.2	5.2
A	D	Q (4) 12 S	0.3	0.7	0.3	0.7	0.3	0.7	8.7
4	D	FL (4) 15 S	0.5	1.5	0.5	1.5	0.5	1.5	8.5
8	E	FL (4) 15 S	1.0	1.0	1.0	1.0	1.0	1.0	8.0
7	D	FL (4) 15 S	1.5	0.5	0.5	0.5	0.5	0.5	10.5
D	E	FL (4) 16 S	0.5	1.5	0.5	1.5	0.5	1.5	9.5
C	D	FL (4) 20 S	0.3	3.0	0.3	3.0	0.3	3.0	9.8
5	D	FL (4) 20 S	0.5	1.5	0.5	1.5	0.5	1.5	13.5
0	D	FL (4) 20 S	0.5	1.5	0.5	1.5	0.5	4.5	10.5
3	F	FL (4) 20 S	1.5	1.5	1.5	1.5	1.5	1.5	9.5
0	F	Q (4) 20 S	0.5	0.5	0.5	0.5	0.5	0.5	16.5
E	E	Q (4) 28 S	0.5	0.5	0.5	0.5	0.5	0.5	24.5
6	F	FL (4) 30 S	0.5	0.5	0.5	0.5	0.5	0.5	26.5

SWITCH	FLASH CODE	ON	OFF	ON	OFF	ON	OFF	ON	OFF	ON	OFF
A	B										
D	D Q (5) 7 S	0.3	0.7	0.3	0.7	0.3	0.7	0.3	0.7	0.3	0.7
E	D Q (5) 10 S	0.3	0.7	0.3	0.7	0.3	0.7	0.3	0.7	0.3	0.7
E	8 FL (5) 12 S	0.5	1.5	0.5	1.5	0.5	1.5	0.5	1.5	0.5	1.5
5	F FL (5) 20 S	0.5	0.5	0.5	0.5	0.5	0.5	0.5	0.5	0.5	0.5
9	F FL (5) 20 S	0.8	1.2	0.8	1.2	0.8	1.2	0.8	1.2	0.8	1.2
9	E FL (5) 20 S	1.0	1.0	1.0	1.0	1.0	1.0	1.0	1.0	1.0	1.0

SWITCH	FLASH CODE	ON	OFF	ON	OFF	ON	OFF	ON	OFF	ON	OFF	ON	OFF
A	B												
F	D Q (6) 10 S	0.3	0.7	0.3	0.7	0.3	0.7	0.3	0.7	0.3	0.7	0.3	0.7
A	F FL (6) 15 S	0.3	0.7	0.3	0.7	0.3	0.7	0.3	0.7	0.3	0.7	0.3	0.7
7	F FL (6) 15 S	0.5	1.0	0.5	1.0	0.5	1.0	0.5	1.0	0.5	1.0	0.5	1.0
A	E FL (6) + LFL 15 S	0.5	1.0	0.5	1.0	0.5	1.0	0.5	1.0	0.5	1.0	0.5	1.0

SWITCH	FLASH CODE	ON	OFF	ON	OFF	ON	OFF	ON	OFF	ON	OFF	ON	OFF	ON	OFF
A	B														
6	E VQ (6) + LFL 10 S	0.2	0.3	0.2	0.3	0.2	0.3	0.2	0.3	0.2	0.3	0.2	0.3	2.0	5.0
7	E VQ (6) + LFL 10 S	0.3	0.3	0.3	0.3	0.3	0.3	0.3	0.3	0.3	0.3	0.3	0.3	2.0	4.4
2	F Q (6) + LFL 15 S	0.2	0.8	0.2	0.8	0.2	0.8	0.2	0.8	0.2	0.8	0.2	0.8	2.0	7.0
2	E Q (6) + LFL 15 S	0.3	0.7	0.3	0.7	0.3	0.7	0.3	0.7	0.3	0.7	0.3	0.7	2.0	7.0
3	E Q (6) + LFL 15 S	0.6	0.6	0.6	0.6	0.6	0.6	0.6	0.6	0.6	0.6	0.6	0.6	2.0	5.8
8	F VQ (6) + LFL 15 S	0.3	0.3	0.3	0.3	0.3	0.3	0.3	0.3	0.3	0.3	0.3	0.3	2.0	9.4

SWITCH	FLASH CODE	ON	OFF	ON	OFF	ON	OFF	ON	OFF	ON	OFF	ON	OFF	ON	OFF	ON	OFF
A	B																
4	E VQ (9) 10 S	0.2	0.3	0.2	0.3	0.2	0.3	0.2	0.3	0.2	0.3	0.2	0.3	0.2	0.3	0.2	0.3
5	E VQ (9) 10 S	0.3	0.3	0.3	0.3	0.3	0.3	0.3	0.3	0.3	0.3	0.3	0.3	0.3	0.3	0.3	0.3
1	F Q (9) 15 S	0.2	0.8	0.2	0.8	0.2	0.8	0.2	0.8	0.2	0.8	0.2	0.8	0.2	0.8	0.2	0.8
0	E Q (9) 15 S	0.3	0.7	0.3	0.7	0.3	0.7	0.3	0.7	0.3	0.7	0.3	0.7	0.3	0.7	0.3	0.7
1	E Q (9) 15 S	0.6	0.6	0.6	0.6	0.6	0.6	0.6	0.6	0.6	0.6	0.6	0.6	0.6	0.6	0.6	0.6

SWITCH	FLASH CODE	ON	OFF	ON	OFF	ON	OFF	ON	OFF
A	B								
MORSE CODE ( ) INDICATES LETTER									
7	8 MO (A) 6 S	0.3	0.6	1.0	4.1				
7	B MO (A) 8 S	0.4	0.6	2.0	5.0				
8	8 MO (A) 8 S	0.8	1.2	2.4	3.6				
B	8 MO (U) 10 S	0.3	0.7	0.3	0.7	0.9	7.1		
C	8 MO (U) 10 S	0.4	0.6	0.4	0.6	1.2	6.8		
D	8 MO (U) 10 S	0.5	0.5	0.5	0.5	1.5	6.5		
9	8 MO (A) 10 S	0.5	0.5	1.5	7.5				
8	9 MO (D) 10 S	5.0	1.0	1.0	1.0	1.0	1.0		
A	8 MO (A) 15 S	0.5	1.5	2.0	11.0				
F	8 MO (U) 15 S	0.6	0.3	0.6	0.3	1.4	11.8		
0	9 MO (U) 15 S	0.7	0.5	0.7	0.5	1.9	10.7		
1	9 MO (U) 15 S	0.7	0.7	0.7	0.7	2.1	10.1		
7	D MO (B) 15 S	1.5	0.5	0.5	0.5	0.5	0.5	0.5	10.5



## Maintenance and Servicing

Designed to be maintenance free, the SL60 requires minimal attention, though the following maintenance and servicing information is provided to help ensure the life of your Sealite product.

1. **Cleaning Solar Panels** - occasional cleaning of the solar panels may be required. Using a cloth and warm soapy water, wipe off any foreign matter before rinsing the panels with fresh water.
2. **Battery Check** - inspection of batteries should be performed every three years (minimum) to ensure that the charger, battery and ancillary electronics are functioning correctly. Using a voltage meter, check that the battery voltage is at least 3.6 volts under 100MA load, and ensure all terminals are clear of foreign matter.

### Replacing the battery- Don't throw the unit out!!

The SL60 lanterns are the only compact marine lantern with a double sealed battery compartment. This provides the user with the ability to change the battery after years of operation.

1. Remove the marked flash adjustment bung from the base of the lantern and set internal toggle switch to 'OFF'.
2. Unscrew small screws to remove battery plate.
3. Remove battery from SL60 case and unscrew positive and negative leads.
4. Discard old battery in a safe manner.
5. Reattach positive and negative leads to new battery and then place back into case.
6. Reattach battery plate and switch lantern 'ON' via internal switch. Close the bung.
7. To test place dark cover (towel or jacket) on top of light to activate sensor, light will come on.

***Care must be taken to observe the polarity of the battery before the leads are re-connected, and ensure the replacement battery is correctly fitted. Always discard old batteries in a safe manner.***

### Long Term Storage Instructions

If the SL60 is to be placed in storage for an extended period, being more than 5 months, please follow the below steps.

1. The 3.6V NiMH Battery must be stored in a fully charged condition.
2. Remove the Flash Adjustment plug and turn the ON/OFF switch to the OFF position.
3. Remove the battery cover and disconnect the Positive (+) Terminal.
4. Fold the Terminal away from the Negative Battery Terminal.
5. Replace the Battery Cover
6. Replace the Flash Adjustment Plug.

All batteries will discharge over time and the rate of discharge is dependent on temperature. If the light is being stored in temperatures greater than 40°C the battery will discharge faster.

Please check battery every 3-6 months and recharge if necessary.

### Recharging the Battery

1. Remove the Battery Cover and connect the Positive Terminal.
2. Remove the Flash Adjustment Plug and turn the ON/OFF switch to the ON position.
3. Reconnect the battery and place unit in the sun for 2-4 days

Or

Reconnect battery and place in front of a halogen lamp for 2-3 days. (Do not place the halogen light too close to the solar panel or the panel may be overheated)

Check the battery voltage regularly to make sure the unit is charging correctly.

After the battery has been recharged, switch the light OFF.

## Trouble Shooting

Problem	Remedy
Lantern will not activate.	<ul style="list-style-type: none"> <li>• Ensure internal toggle switch is set to the 'ON position.</li> <li>• Ensure lantern is in darkness.</li> <li>• Wait at least 60 seconds for the program to initialise in darkness.</li> <li>• Ensure switch setting is on a valid code (See <i>Flash Codes</i> section of this manual).</li> <li>• Ensure battery terminals are properly connected.</li> <li>• Ensure battery voltage is above 3.4volts.</li> </ul>
Timing codes will not change.	<ul style="list-style-type: none"> <li>• Turn rotary switches several times to ensure contacts are clear.</li> </ul>
Lantern will not operate for the entire night.	<ul style="list-style-type: none"> <li>• Expose lantern to direct sunlight and monitor operation for several days. Sealite products typically require 1.5 hours of direct sunlight per day to retain full autonomy. From a discharged state, the lantern may require several days of operational conditions to 'cycle' up to full autonomy.</li> <li>• Reducing the light output intensity or duty cycle (flash code) will reduce current draw on the battery.</li> <li>• Ensure solar module is clean and not covered by shading during the day.</li> </ul>
Lantern is constantly on during the day.	<ul style="list-style-type: none"> <li>• Ensure the flash code is not set to F F. This flash code is for testing purposes only and will be steady on for 24 hours a day.</li> </ul>

**SL60 Optional Configurations**

**200mm OD Base (SL60-LB)**

Available with larger 200mm OD base pattern for immediate installation on existing structures.

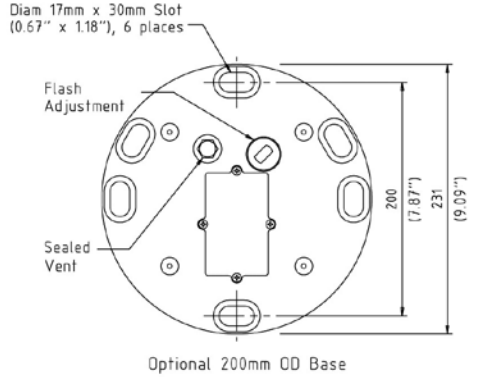
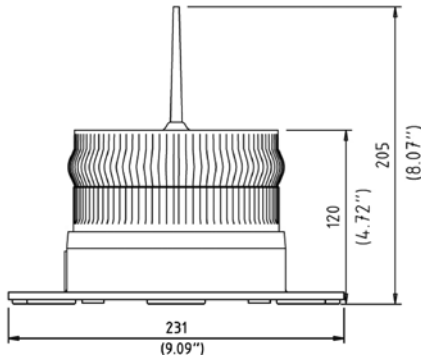

**8Ah Battery (SL60/8Ah) or 16Ah Battery (SL60-LB/16Ah)**

Available with 8Ah battery for low sunlight regions, or high duty cycles.

**SL60 Accessories**



**MC/02**

Post mounting plate to suit standard base SL60  
50mm ID



**MC/03**

Post mounting plate to suit 200mm OD base SL60-LB  
50mm ID



**MC/05**

90 degree wall mounting stand  
50mm OD



**MC/10**

Buoy mounting plate to affix standard base SL60 lantern to  
SLB600, SLB610 & SLB700 buoys



**MC/11**

Buoy mounting plate to affix SL60-LB lantern with 200mm OD base  
to SLB600, SLB610 & SLB700 buoys



**MC/15**

316-grade SS bolt set to suit standard base SL60 hardware  
M4 x 20mm



**MC/16**

316-grade SS bolt set to suit SL60-LB lantern with 200mm OD base  
hardware  
M8 x 25mm





**Notes**



## Sealite LED Light Warranty V2.1

### Activating the Warranty

Upon purchase, the Sealite Pty Ltd warranty must be activated for recognition of future claims. To do this you have two (2) options:

1. **Postal Registration** - please complete the Sealite Warranty Registration Card and return to Sealite within 30 days of your purchase.
2. **Online Registration** - please complete the Online Registration Form at; [www.sealite.com](http://www.sealite.com)

***Sealite Pty Ltd will repair or replace your LED light in the event of electronic failure for a period of up to three years from the date of purchase.***

***The unit must be returned to Sealite freight prepaid.***

### Warranty Terms

1. Sealite Pty Ltd warrants that any Sealite marine products fitted with telemetry equipment including but not limited to AIS, GSM, GPS or RF ("Telemetry Products") will be free from defective materials and workmanship under normal and intended use, subject to the conditions hereinafter set forth, for a period of twelve (12) months from the date of purchase by the original purchaser.
2. Sealite Pty Ltd warrants that any BargeSafe™ Series of LED barge light products ("BargeSafe™ Products") will be free from defective materials and workmanship under normal and intended use, subject to the conditions hereinafter set forth, for a period of twelve (12) months from the date of purchase by the original purchaser.
3. Sealite Pty Ltd warrants that any LED area lighting products ("Area Lighting Products") but not including sign lighting products will be free from defective materials and workmanship under normal and intended use, subject to the conditions hereinafter set forth, for a period of twelve (12) months from the date of purchase by the original purchaser.
4. Sealite Pty Ltd warrants that any LED sign lighting products ("Sign Lighting Products") will be free from defective materials and workmanship under normal and intended use, subject to the conditions hereinafter set forth, for a period of three (3) years from the date of purchase by the original purchaser.
5. Sealite Pty Ltd warrants that any Sealite marine lighting products other than the Telemetry Products, BargeSafe™ Products, and Area Lighting Products ("Sealite Products") will be free from defective materials and workmanship under normal and intended use, subject to the conditions hereinafter set forth, for a period of three (3) years from the date of purchase by the original purchaser.
6. Sealite Pty Ltd will repair or replace, at Sealite's sole discretion, any Telemetry Products, BargeSafe™ Products, Area Lighting Products or Sealite Products found to be defective in material and workmanship in the relevant warranty period so long as the Warranty Conditions (set out below) are satisfied.
7. If any Telemetry Products, BargeSafe™ Products, Area Lighting Products or Sealite Products are fitted with a rechargeable battery, Sealite Pty Ltd warrants the battery will be free from defect for a period of one (1) year when used within original manufacturer's specifications and instructions.

### Warranty Conditions

This Warranty is subject to the following conditions and limitations;

1. The warranty is applicable to lanterns manufactured from 1/1/2009.
2. The warranty is void and inapplicable if:
  - a. the product has been used or handled other than in accordance with the instructions in the owner's manual and any other information or instructions provided to the customer by Sealite;
  - b. the product has been deliberately abused, or misused, damaged by accident or neglect or in being transported; or
  - c. the defect is due to the product being repaired or tampered with by anyone other than Sealite or authorised Sealite repair personnel.

3. The customer must give Sealite Pty Ltd notice of any defect with the product within 30 days of the customer becoming aware of the defect.
4. Rechargeable batteries have a limited number of charge cycles and may eventually need to be replaced. Typical battery replacement period is 3-4 years. Long term exposure to high temperatures will shorten the battery life. Batteries used or stored in a manner inconsistent with the manufacturer's specifications and instructions shall not be covered by this warranty.
5. No modifications to the original specifications determined by Sealite shall be made without written approval of Sealite Pty Ltd.
6. Sealite lights can be fitted with 3rd party power supplies and accessories but are covered by the 3rd party warranty terms and conditions.
7. The product must be packed and returned to Sealite Pty Ltd by the customer at his or her sole expense. Sealite Pty Ltd will pay return freight of its choice. A returned product must be accompanied by a written description of the defect and a photocopy of the original purchase receipt. This receipt must clearly list model and serial number, the date of purchase, the name and address of the purchaser and authorised dealer and the price paid by the purchaser. On receipt of the product, Sealite Pty Ltd will assess the product and advise the customer as to whether the claimed defect is covered by this warranty.
8. Sealite Pty Ltd reserves the right to modify the design of any product without obligation to purchasers of previously manufactured products and to change the prices or specifications of any product without notice or obligation to any person.
9. Input voltage shall not exceed those recommended for the product.
10. Warranty does not cover damage caused by the incorrect replacement of battery in solar lantern models.
11. This warranty does not cover any damage or defect caused to any product as a result of water flooding or any other acts of nature.
12. There are no representations or warranties of any kind by Sealite or any other person who is an agent, employee, or other representative or affiliate of Sealite, express or implied, with respect to condition of performance of any product, their merchantability, or fitness for a particular purpose, or with respect to any other matter relating to any products.

### **Limitation of Liability**

To the extent permitted by section 68A of the Trade Practices Act 1974 (Cth), the liability of Sealite Pty Ltd under this Warranty will be, at the option of Sealite Pty Ltd, limited to either the replacement or repair of any defective product covered by this Warranty. Sealite will not be liable to Buyer for consequential damages resulting from any defect or deficiencies.

### **Limited to Original Purchaser**

This Warranty is for the sole benefit of the original purchaser of the covered product and shall not extend to any subsequent purchaser of the product.

### **Miscellaneous**

Apart from the specific warranties provided under this warranty, all other express or implied warranties relating to the above product is hereby excluded to the fullest extent allowable under law. The warranty does not extend to any lost profits, loss of good will or any indirect, incidental or consequential costs or damages or losses incurred by the purchaser as a result of any defect with the covered product.

### **Warrantor**

Sealite Pty Ltd has authorised distribution in many countries of the world. In each country, the authorised importing distributor has accepted the responsibility for warranty of products sold by distributor. Warranty service should normally be obtained from the importing distributor from whom you purchased your product. In the event of service required beyond the capability of the importer, Sealite Pty Ltd will fulfil the conditions of the warranty. Such product must be returned at the owner's expense to the Sealite Pty Ltd factory, together with a photocopy of the bill of sale for that product, a detailed description of the problem, and any information necessary for return shipment.

**Other Sealite Products Available**



**Marine Lanterns  
(1-12nm+)**



**Monitoring  
& Control Systems**



**Bridge & Barge Lights**



**Marine Buoys  
(up to 3mt in diameter)**

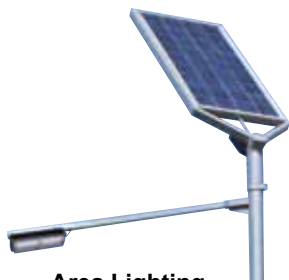

**Area Lighting**



**Mooring Systems  
& Accessories**



**Sealite**  
www.sealite.com

**Head Office**  
Sealite Pty Ltd  
11 Industrial Drive  
Somerville, Vic 3912  
Australia  
Tel: +61 3 5977 6128  
Fax: +61 3 5977 6124  
Email: info@sealite.com  
Internet: www.sealite.com

