



**Cybex VR3[®] Cable Column
Owner's and Service Manual
Strength Systems
Part Number 12220-999-4 G**



**Cybex VR3[®] Cable Column
Owner's and Service Manual
Strength Systems
Part Number 12220-999-4 G**

Cybex[®] and the Cybex logo are registered trademarks of Cybex International, Inc.
VR3[®] and its mark are registered trademarks of Cybex International, Inc.

DISCLAIMER: Cybex International, Inc., makes no representations or warranties regarding the contents of this manual. We reserve the right to revise this document at any time or to make changes to the product described within it without notice or obligation to notify any person of such revisions or changes.

© Copyright 2010, Cybex International, Inc. All rights reserved.

Printed in the United States of America.
10 Trotter Drive Medway, MA 02053 • 508-533-4300 • FAX 508-533-5183
www.cybexinternational.com • techhelp@cybexintl.com • 12220-999-4 G • March 2010

Table of Contents

1 Safety	
Safety	1-1
Safety Guidelines and Practices	1-2
Warning/Caution Decals	1-3
Regular Maintenance Activities	1-6
Using Proper Form	1-6
2 Exercises	
Intended Use	2-1
Instructions	2-2
3 Customer Service	
Contacting Service	3-1
Ordering parts	3-1
Return Material Authorization (RMA)	3-2
Damaged Parts	3-3
4 Assembly	
Assembly	4-1
5 Maintenance	
Daily Procedures	5-1
Weekly Procedures	5-4
Yearly Procedures	5-6
Environment	5-7
Storage	5-7
6 Service	
Parts Lists	6-4
Exploded-View Diagram	6-5

1 - Safety

Safety

Read the Owner's Manual carefully before assembling, servicing or using the equipment.

It is the responsibility of the facility owner and/or owner of the equipment to instruct users on proper operation of the equipment and review all labels.



WARNING: Serious injury could occur if these safety precautions are not observed:

User Safety Precautions

- Obtain a medical exam prior to beginning an exercise program.
- Read and understand warning labels and user manual prior to exercising. Obtain instruction prior to use. 
- Keep body and clothing free from and clear of all moving parts.
- Inspect machine prior to use. **DO NOT** use if it appears damaged or inoperable.
- **DO NOT** attempt to fix a broken or jammed machine. Notify floor staff.
- Use the machine only for the intended use. **DO NOT** modify the machine.
- Be sure that the weight pin is completely inserted. Use only the pin provided by the manufacturer. If unsure seek assistance.
- Never pin the weights in an elevated position. **DO NOT** use the machine if found in this condition. See assistance from floor staff.
- Children must not be allowed near these machines. Teenagers must be supervised.
- **DO NOT** use if guards are missing or damaged.
- **DO NOT** use dumbbells or other incremental weights, except those provided by the manufacturer.
- Inspect all cables and belts and connections prior to use. **DO NOT** use if any components are worn, frayed or damaged.
- **DO NOT** remove any labeling from equipment. Replace any damaged labels.
- Stop exercising if you feel faint, dizzy or experience pain at any time while exercising and consult your physician.

Facility Safety Precautions

- Read the Owner's Manual carefully before assembling, servicing or using the equipment.
- Securely anchor each machine to the floor using the anchor holes provided in each machine.

NOTE: *Cybex is not responsible for the actual anchoring of equipment. Consult with a professional contractor.*

NOTE: *Use fasteners having a minimum of 500 lbs. tensile capacity (3/8" grade 2 bolts or better).*

NOTE: *If legs/frame does not contact surface, DO NOT pull down with anchors. Shim any leg or frame not in contact with surface using flat washers.*

Cybox VR3 12220 Cable Column Owner's Manual

- Make sure that each machine is set up and operated on a solid level surface. **Do not install equipment on an uneven surface.**
- Make sure that all users are properly trained on how to use the equipment.
- Make sure there is enough room for safe access and operation of the equipment.
- Perform regular maintenance checks on the equipment. Also pay close attention to all areas most susceptible to wear, including (but not limited to) cables, pulleys, belts and grips.
- Immediately replace worn or damaged components. If unable to immediately replace worn or damaged components then remove from service until the repair is made.
- Use only Cybox supplied components to maintain/repair the equipment.
- Keep a repair log of all maintenance activities.
- Inspect all cables and belts and connections prior to use. **DO NOT** use if any components are worn, frayed or damaged.

NOTE: *It is the sole responsibility of the user/owner or facility operator to ensure that regular maintenance is performed.*

Safety Guidelines And Practices

Cybox recommends that all fitness equipment be used in a supervised area. It is recommended that the equipment be located in an access controlled area. Control is the responsibility of the owner. The extent of control is at the discretion of the owner.

It is the responsibility of the purchaser/user of Cybox products to read and understand the owner's manual, and warning labels; as well as instruct all individuals, whether end users or supervising personnel, on proper usage of the equipment.

PROPER USAGE:

Use machine only as described in the manual. Failing to follow proper instructions may result in injury.

Do Not Lean Against or Pull On the framework, weight stack, or any component, whether machine is at rest or in use. Inappropriate or improper use may result in injury to users or third parties (bystanders).

Do not use machine if it is not located on a solid level surface or is improperly installed.

Provide an adequate safety perimeter between the machine, walls and other equipment to ensure that the facility has the proper clearance for usage and training.

SECURING EQUIPMENT:

The machine has holes in the feet, which allow for ease in anchoring to the floor. Cybox strongly recommends that, to eliminate rocking, tipping or falling over due to incorrect usage and misuse, equipment be secured to a solid, level surface.

1. The solid, level surface should not deviate more than 1/8" over a 10' distance or as defined and required by local building and architectural codes.
2. Anchoring of equipment must be completed by a qualified licensed contractor.

3. Anchoring holes are provided on the feet of the frame. All anchoring locations must be used when anchoring the equipment to the floor.
4. Due to the wide variation of flooring on which machines may be anchored or installed, verify anchoring method and anchoring fasteners with a qualified and licensed contractor.
5. A minimum pull out force of 220 lbs/100 kgs is required for each anchor position..
6. Do not use machine until it is properly anchored.

MAINTENANCE:

Preventative maintenance allows proper equipment operation and reduces the risk of injury. Perform the maintenance requirements as specified in the manual.

STANDARD COMPLIANCE:

Cybex products meet or exceed applicable ASTM and EN Standards.



Warning/Caution Decals

Warning decals indicate a potentially hazardous situation, which, if not avoided, could result in death or serious injury.

Caution decals indicate a potentially hazardous situation, which, if not avoided, could result in minor or moderate injury.

The warning and caution decals are shown on the following page. The diagrams following the decals show where each decal is located.

! WARNING

SERIOUS INJURY
COULD OCCUR IF
THESE PRECAUTIONS
ARE NOT OBSERVED

1. Obtain a medical exam prior to beginning an exercise program.
2. Read and understand warning labels and user manual prior to exercising. Obtain instruction prior to use. 
3. Keep body and clothing free from and clear of all moving parts.
4. Inspect machine prior to use. DO NOT use if it appears damaged or inoperable.
5. DO NOT attempt to fix a broken or jammed machine. Notify floor staff.
6. Use the machine only for the intended use. DO NOT modify the machine.
7. Be sure that the weight pin is completely inserted. Use only the pin provided by the manufacturer. If unsure seek assistance.
8. Never pin the weights in an elevated position. DO NOT use the machine if found in this condition. Seek assistance from floor staff.
9. Children must not be allowed near this machine. Teenagers must be supervised.
10. DO NOT use if guards are missing or damaged.
11. DO NOT use dumbbells or other incremental weights, except those provided by the manufacturer.
12. Inspect all cables and belts and connections prior to use. DO NOT use if any components are worn, frayed, or damaged.
13. DO NOT REMOVE THIS LABEL. REPLACE IF DAMAGED.

4605-381-4 A

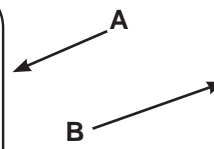

! CAUTION

Personal injury may occur.

Keep away from moving parts to avoid injury.

4000Y316-4

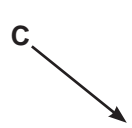

! CAUTION

Failure to correctly adjust could result in personal injury.

Always fully engage the detent pin before use to avoid injury.

8500-025-4

Cable Column - 12220

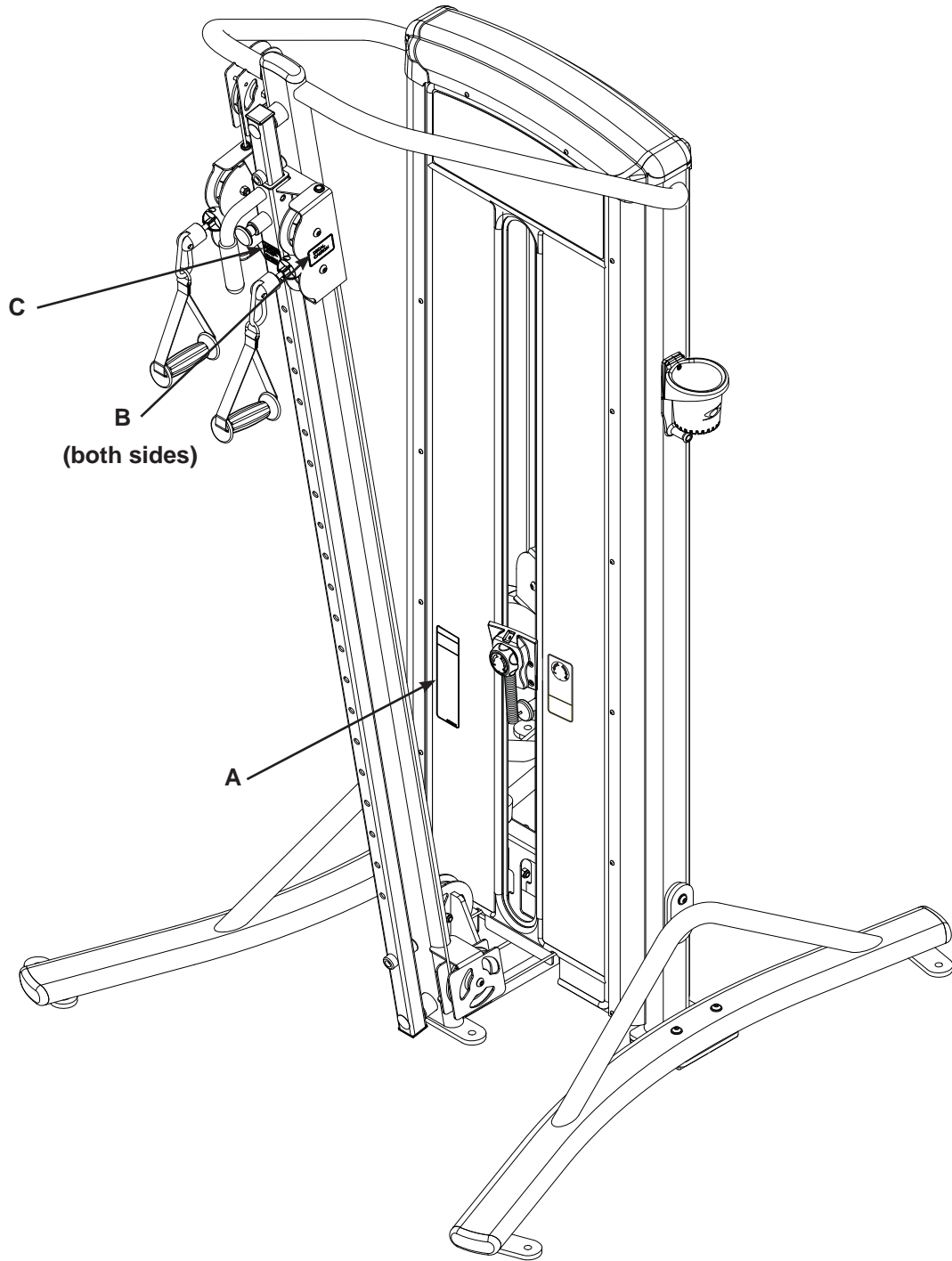

DESCRIPTION	PART NO.
A. Warning Label	4605-381-4
B. Caution Decal	4000Y316-4
C. Caution Decal	8500-025-4

Regular Maintenance Activities

Preventative maintenance activities must be performed to maintain normal operation of your equipment. Keeping a log sheet of all maintenance actions will assist you in staying current with all preventative maintenance activities. The preventative maintenance actions are described in detail in Chapter 5. Briefly, they include:

Daily

1. Clean upholstery.

Weekly

1. Inspect all nuts and bolts for looseness. Tighten as required.
2. Inspect all cables and belts for damage or wear (see Chapter 5). **If a cable or belt is worn or damaged, immediately discontinue use until cable or belt has been replaced.**
3. Check for worn handles, worn snap links, and worn warning labeling. Replace all worn parts immediately.
4. Inspect for loose or worn grips. Replace all loose or worn grips immediately.
5. Inspect weight stacks for proper alignment and operation. Correct all improper alignment and operation issues immediately.
6. Lubricate guide rods using automotive engine oil only.

Yearly

1. Replace all cables and belts at least annually.

Using Proper Form

Before working out, read and understand the exercises located on the placard and in Chapter 2.

2 - Exercise

The cable column allows for virtually unlimited training opportunities.

Intended Use

The intended use of this equipment is to aid or improve general physical fitness and exercise. For Commercial use.

Instructions

Read and understand all instructions and warnings prior to using this machine. See Chapter 1, Safety in the VR3 Owner's Manual or consult with floor staff.

1. To adjust cable carriage to desired height:
 - Pull knob
 - Adjust carriage up or down
 - Release knob and lock carriage in place
2. Use one or both handles.
3. Direction of cable represents direction of force.
4. Table represents resistance in each handle or attachment.

NOTE: All adjustment points on the machine have yellow handles or knobs.

NOTE: Do not turn knob when weight stack is elevated.

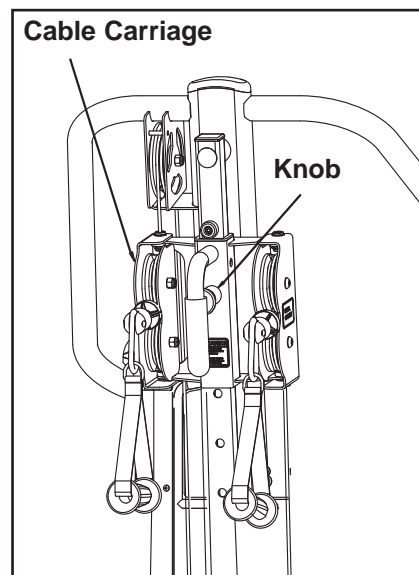

Resistance Per Handle

Plate Number	Lbs	Kg
Plate Top	2.50	1.25
2	7.50	3.50
3	12.50	5.75
4	17.50	8.00
5	22.50	10.25
6	27.50	12.50
7	32.50	14.75
8	37.50	17.00
9	42.50	19.25
10	47.50	21.50
11	52.50	23.75
12	57.50	26.00
13	62.50	28.25
14	67.50	30.50
15	72.50	32.75

On the increment weight knob, the incremental resistance is 1/4 that displayed per handle.

This page intentionally left blank.

3 - Customer Service

Contacting Service

Hours of phone service are Monday through Friday from 8:30 to 6:00 p.m. Eastern Standard Time.

For Cybox customers living in the USA, contact Cybox Customer Service at **888-462-9239**.

For Cybox customers living outside the USA, contact Cybox Customer Service at **508-533-4300** or fax **508-533-5183**.

Order parts and find information on the web at www.eCybox.com or by e-mail at techhelp@cyboxintl.com.

Ordering Parts

Fax orders to **508-533-5183**. To speak with a customer service representative, call **888-462-9239** (for customers living within the USA) or **508-533-4300** (for customers outside the USA). You may also contact us through e-mail at techhelp@cyboxintl.com

Having the following information ready when calling will assist our Cybox representatives in serving you.

- **Unit Serial Number**
- **Product Name**

The unit serial number and product name can be found on the serial number decal. See Chapter 6 for exact location of serial number decal.

- **Part Description**
- **Part Number**

Part descriptions and part numbers are located in Chapter 6 of this manual.

- **Shipping Address**
- **Contact Name**

In addition to your shipping address and contact name, your account number is helpful but not required.

Return Material Authorization (RMA)

The Return Material Authorization (RMA) system outlines the procedures to follow when returning material for placement, repair or credit. The system assures that returned materials are properly handled and analyzed. Follow the following procedures carefully.

Contact your authorized Cybex dealer on all warranty-related matters. Your local Cybex dealer will request a RMA from Cybex, if applicable. Under no circumstances will defective parts or equipment be accepted by Cybex without proper RMA and an Automated Return Service (ARS) label.

- 1. Call the Customer Service Hot Line listed above for the return of any item that is defective.**
- 2. Provide the technician with a detailed description of the problem you are having or the defect in the item you wish to return.**
- 3. Provide the model and serial number of your Cybex equipment.**
- 4. At Cybex's discretion, the technician may request that you return the problem part(s) to Cybex for evaluation and repair or replacement. The technician will assign you a RMA number and will send you an ARS label. The ARS label and the RMA numbers must be clearly displayed on the outside of the package that contains the item(s) to be returned. Include the description of the problem, the serial number of the equipment and the name and address of the owner in the package along with the part(s).**
- 5. Forward the package through UPS to Cybex.**

Attn: Customer Service Department

Cybex International, Inc.

1975 24th Ave SW

Owatonna, MN 55060

NOTE: Merchandise returned without an RMA number on the outside of the package or shipments sent COD will not be accepted by the Cybex receiving department.

Damaged Parts

Materials damaged in shipment should not be returned for credit. Shipping damages are the responsibility of the carrier (UPS, Federal Express, trucking companies, etc.)

Apparent Damage - Upon receipt of your shipment, check all items carefully. Any damage seen with a visual check must be noted on the freight bill and signed by the carrier's agent. Failure to do so will result in the carriers refusal to honor your damage claim. The carrier will provide you with the required forms for filing such claims.

Concealed Damage - Damage not seen with a visual check upon receipt of a shipment but notices later must be reported to the carrier as soon as possible. Upon discovery of the damage, a written or phone request to the carrier asking them to perform an inspection of the materials must be made within ten days of the delivery date. Keep all shipping containers and packing materials as they will be needed in the inspection process. The carrier will provide you with an inspection report and the necessary forms for filing a concealed damage claim. Concealed damage claim is the carrier's responsibility.

This page intentionally left blank

4 - Assembly

TOOLS REQUIRED

- 7/32" Allen wrench
- 1/8" Allen wrench
- Medium weight automotive engine oil
- Torque wrench
- 3/4" Wrench

NOTE: Two people will be required for this procedure.

NOTE: It is the responsibility of the facility owner/owner of the equipment to ensure that there is appropriate clearance around each machine to allow for safe use and passage.

NOTE: Refer to chapter 6 for reference diagrams.

1. **Read and understand all instructions thoroughly before starting any of the procedures listed on this instruction sheet.**
2. **Verify you have received the appropriate configuration.**
 - A. Verify that you received the correct color machine that you ordered.
 - B. Verify you received the proper weight stack.
 - C. Verify you received the appropriate owner's manual.
 - D. Verify you received the warranty sheet.
 - E. Verify you received the weight stack decals.
3. **Move to desired location.**
4. **Remove shipping feet.**

 **WARNING:** Use extreme caution when removing shipping cones and installing feet. Failure to do so could result in injury.

- A. With an assistant, carefully remove each (standard) cone-shaped shipping support using a 3/4" socket or wrench.
 - B. Cut shipping tie securing top weight.
 - C. Carefully place rubber feet (supplied with machine) on each foot of the frame.
5. **Installing the weight stack.**
 - A. If weight stack is already installed, proceed to step 9.
 - B. Using a 1/8" Allen wrench, remove the two Button Head Socket Cap Screws (BHSCS) securing the bottom bracket to the frame. **NOTE:** Do not remove middle BHSCS securing shroud to bottom bracket.
 - C. Remove the remaining BHSCS securing the back shroud to the frame. **NOTE:** After final BHSCS is removed shroud will slide down to the floor with bottom support bracket attached.
 - D. Carefully slide shroud out of machine.

- E. Slide spring loaded top guide rod cap down guide rod until guide rod cap is clear of frame.
NOTE: Top guide rod cap is spring loaded.
- F. Slowly release grasp of guide rod cap. **NOTE:** Guide rod cap contains a compression spring that will fly if grasp is not released slowly.
- G. Remove guide rod cap and spring and set aside.
- H. Repeat steps 5F-5H for other rod guide.
- I. Carefully lean guide rods slightly outward, away from machine to clear pulley. **NOTE:** Excessive pressure on guide rods may damage lower guide rod caps.
- J. Slide top weight up and out of machine. Carefully hang over top of machine so cables and top weight are out of the way when installing weight plates.
- K. Wipe guide rods clean over entire length. Lubricate with light coating of medium weight automotive engine oil.
- L. Have an assistant hold the guide rods vertical.
- M. Carefully align weight plate over guide rods and slowly lower weight plate. **NOTE:** When installing weight plates, position plates so wide edges of bushing face upward and narrow edges of bushing face downward. See Figures 1A and 1B.
- N. Repeat step 5M-5N to install each weight plate.

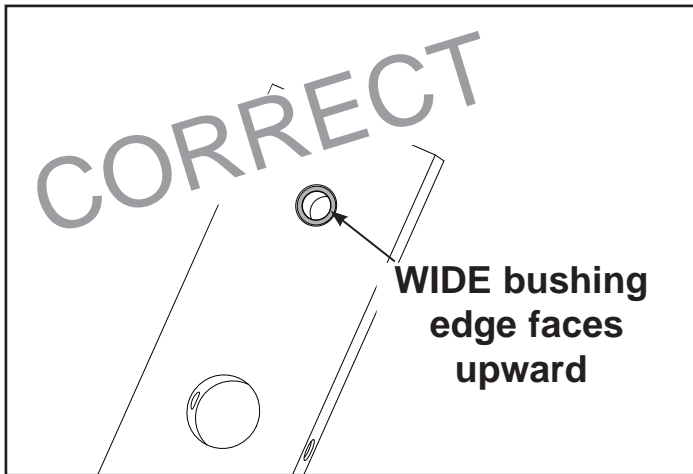

Figure 1A

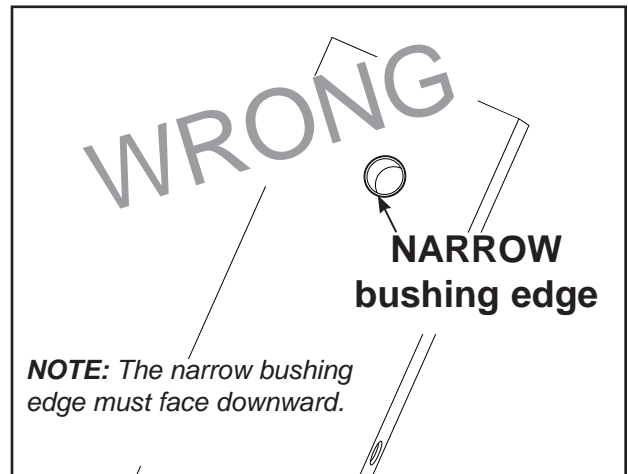

Figure 1B

- O. Carefully slide top weight over guide rods. **NOTE:** Do not twist top weight or cables. Cables must glide smoothly through pulley
- P. Place springs and guide rod caps on guide rods (removed from step 5G).
- Q. Compress guide rod caps and align guide rod caps with weight frame holes and secure in place.
NOTE: Guide rod caps must snap or lock into weight frame holes.

6. Cable Routing.

- A. Verify cable is routed through pulley brackets. **NOTE:** Verify cable is not twisted. See Figure 2.
- B. Place weight stack pin in each plate to verify proper installation.
- C. Without selecting any resistance, lift top weight up and down (simulating normal operation).
- D. Have an assistant verify that the cable is moving smoothly and is routed straight from the top of pulley bracket to the top weight.
- E. Turn the Increment Weight Adjusting Knob to select 0 lbs or 0 kg.

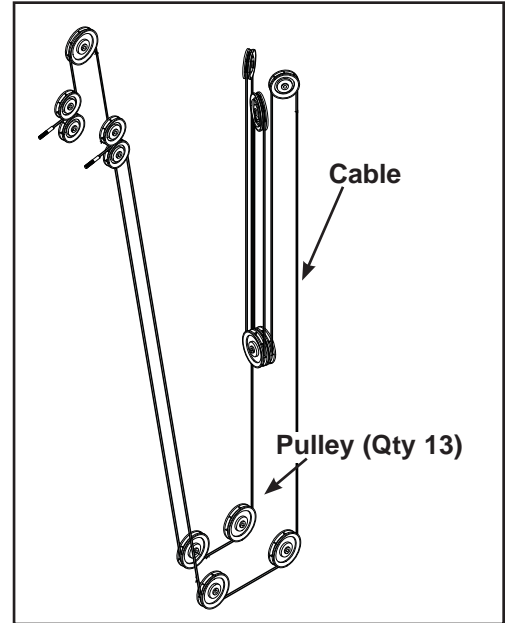

Figure 2

7. Install back shrouds.

- A. Carefully place shroud into position.
- B. Starting at the bottom replace the two BHSCS (removed in step 5D) to secure bottom support bracket to the shroud. Install but do not tighten remaining BHSCS securing shroud.
- C. Tighten all BHSCS.

8. Install weight plate decals.

- A. Slowly and carefully peel off back side of decal. **NOTE:** When peeling off back cover, make sure that the decals remain attached to the front sticker. Figure 3.
- B. Insert a guide pin through each hole of the template. **NOTE:** A guide pin can be anything that fits through the weight stack hole, such as a weight stack selector pin.
- C. Carefully align decal and rub it onto weight plates.
- D. Carefully remove front side, leaving decals adhering to weight plates. See Figure 4.

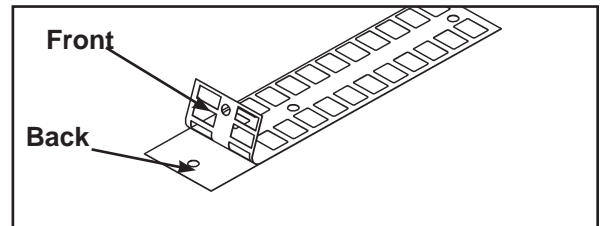

Figure 3

NOTE: It is important that you perform regular inspection and maintenance activities on your equipment. See the CYBEX VR3 Owner's Manual for inspection and maintenance activities. If you do not have a CYBEX Owner's Manual or if you have any questions or concerns, call CYBEX Customer Relations at 1-888-462-9239.

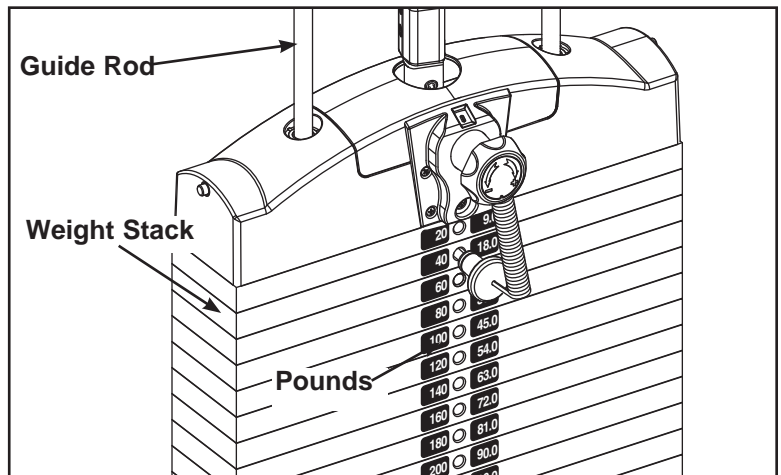

Figure 4

9. Verify proper operation

10. Securely anchor machine to the floor.

- A. Securely anchor machine to the floor using the anchor holes provided in each machine.

NOTE: *Cybox is not responsible for the actual anchoring of equipment. Consult with a professional contractor.*

NOTE: *Use fasteners having a minimum of 500 lbs. tensile capacity (3/8" grade 2 bolts or better).*

NOTE: *If legs/frame does not contact surface, DO NOT pull down with anchors. Shim any leg or frame not in contact with surface using flat washers.*

Chapter 5 - Maintenance

All preventive maintenance activities must be performed on a regular basis. Performing routine preventive maintenance actions can aid in providing safe, trouble-free operation of all Cybex Strength Systems equipment.

NOTE: *Cybex is not responsible for performing regular inspection and maintenance actions for your machines. Instruct all personnel in equipment inspection and maintenance actions and also in accident reporting/recording. Cybex phone representatives are available to answer any questions or concerns that you may have.*



NOTE: *All inspections and repairs must be performed by trained service personnel only.*

Cybex will void warranty if non-Cybex replacement parts are used.

Daily Procedures

1. **Upholstery** - Wipe down all upholstery as per the recommendations listed below for light soiling and more difficult stains.

Light Soiling

- A solution of 10% household liquid dish soap with warm water applied with a soft damp cloth.
- If necessary, a solution of liquid cleanser and water applied with a soft bristle brush. Wipe away the residue with a water dampened cloth.

More Difficult Stains

- Dampen a soft white cloth with a solution of 10% household bleach (sodium hypochlorite), 90% water. Rub gently. Rinse with a water dampened cloth to remove bleach concentration.
- The same procedure can be used with full strength household bleach, if necessary.
- Allow bleach to puddle on the affected area or apply with a soaked cloth for approximately 30 minutes. Rinse with a water dampened cloth to remove any remaining bleach concentration.

Alternative Method for Difficult Stains

- Dampen a soft white cloth with rubbing alcohol and rub gently. Rinse with a water dampened cloth to remove any remaining rubbing alcohol concentration.

NOTE: *To restore luster, a light coat of spray furniture wax can be used. Apply for 30 seconds and follow with a light buffing using a clean white cloth.*

Please Review Carefully

When using strong cleaning agents such as rubbing alcohol or bleach, it is advisable to first test in an inconspicuous area. Other cleaning agents may contain harsh or unknown solvents and are subject to formula changes by the product manufacturer without notice. Should you desire to use other cleaning agents, carefully try them in an inconspicuous area to determine potential damage to the material. Never use harsh solvents or cleaners which are intended for industrial applications. To clean stained or soiled areas, a soft white cloth is recommended. Avoid use of paper towels.

Cleaning products may be harmful/irritating to your skin, eyes, etc. Use protective gloves and eye protection. Do not inhale or swallow any cleaning product. Protect surrounding area/clothing from exposure. Use in a well ventilated area. Follow all product manufacturer's warnings. CYBEX and its vendors cannot be held responsible for damage or injuries resulting from the use or misuse of cleaning products.

- 2. Frames** - Wipe down all frames using a mild solution of warm water and car wash soap. Be sure to dry thoroughly. **AVOID** acid or chlorine based cleaners and also cleaners containing abrasives as these could scratch or damage the equipment.
- 3. Chrome** - Clean chrome tubes, first using chrome polish and then using a car wax seal. Neutral cleaners with a pH between 5.5 and 8.5 are recommended. Be sure to dry thoroughly. **AVOID** acid or chlorine based cleaners and also cleaners containing abrasives as these could scratch or damage the equipment.

4. Guidelines for cleaning front panel:

- Use clean soft cloths or sponges for application of cleaners and again for washing and rinsing.
- Follow up the application with warm water rinse.
- Don't use abrasives or high alkaline cleaners.
- Don't leave cleaners on for long periods, wash immediately.
- Don't apply cleaners in direct sunlight or at elevated temperatures.
- Don't use scrapers, squeegees or razors.
- Don't clean with gasoline.

Compatible Cleaners and Detergents:

- Formula 409
- Top Job
- Joy
- Palmolive
- Windex with Ammonia D

To Minimize Fine or Hairline Scratches:

Mild automotive polish applied and removed with a soft, clean cloth will help fill scratches.



Suggested Polishes:

- Johnson Paste Wax
- Mirror Glaze #10 Plastic Polish (by Mirror Bright Polish Co.)
- Novus Plastics Polish #1, #2 (by Novus Inc.)

Weekly Procedures

1. Check all nuts and bolts for looseness. Tighten as required.
2. Inspect all belts (entire length) for any **non-uniformity and wear**.

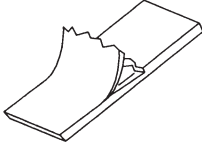
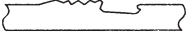
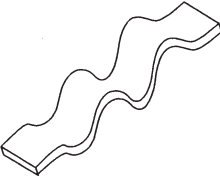
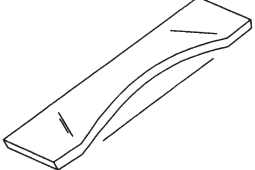
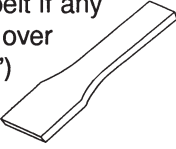
Immediately replace belt if any of the following conditions are present:

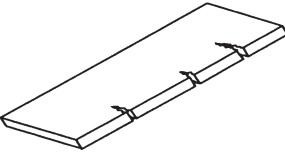
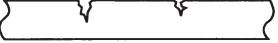
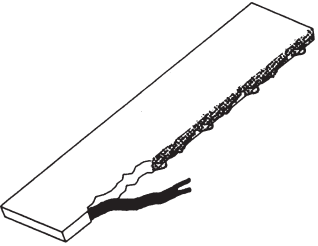
	3D View	3D or Side View
<ul style="list-style-type: none"> • Peeling of the belt's skin. 		
<ul style="list-style-type: none"> • Wave in the belt. 		
<ul style="list-style-type: none"> • Belt is necked down (narrow section). 	<p>Replace belt if any section is over 1/32" (.03") narrower than rest of the belt.</p> 	 <p>Examine edge of belt (both sides). Replace belt if any section is narrower than the rest.</p>
<ul style="list-style-type: none"> • Cracks or splits. 		
<ul style="list-style-type: none"> • One or more strands of kevlar hanging out. <i>NOTE: Also replace belt if there is a significant amount of frayed kevlar.</i> 		

3. Some machines use cables in addition to belts. Inspect all cables for wear or damage and proper tension. When inspecting cables, run your fingers on the cable, paying particular attention to bends in the cable and attachment points.

Replace all worn cables immediately. The following conditions may indicate a worn cable:

- A tear or crack in the cable sheath that exposes the cable. See Figure 1

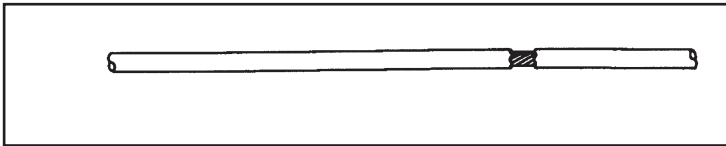

Figure 1

- A kink in the cable. See Figure 2.

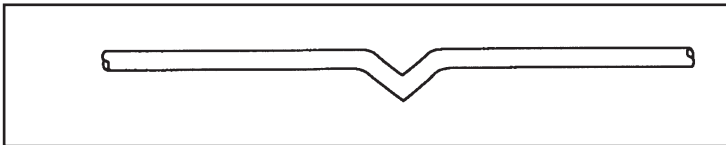

Figure 2

- A curled sheath. See Figure 3.

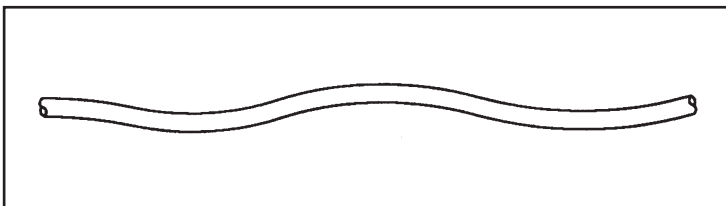

Figure 3

- "Necking", a stretched cable sheath. See Figure 4.

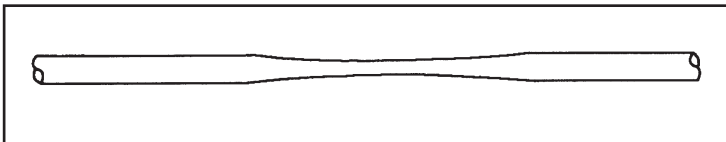

Figure 4

4. Inspect bars and handles for wear, paying particular attention to tab area connecting points.

Replace all worn handles immediately.

5. Inspect snap links for proper latching (indicates wear).

Replace all worn snap links immediately.

6. Inspect for loose or worn grips.

Replace all loose or worn grips immediately.

7. Inspect all labeling for readability. This includes instructional placards, warning and caution decals.

Replace all worn labeling immediately.

8. Inspect all weight stacks for proper alignment and operation.

Correct all improper alignment and operation issues immediately.

9. Wipe *Weight Stack Guide Rods* clean over entire length. Lubricate with a light coat of medium weight automotive engine oil.

Yearly Procedures

1. Replace all belts and cables at least annually.

Environment

Static Electricity - Depending upon where you live, you may experience dry air, causing a common experience of static electricity. This may be especially true in the winter time. You may notice a static build-up just by walking across a carpet and then touching a metal object. The same can hold true while working out on your unit. You may experience a shock due to the build-up of static electricity on your body and the discharge path of the unit. If you experience this type of situation, you may want to increase the humidity to a comfortable level through the use of a humidifier.

Humidity - The unit is designed to function normally in an environment with a relative humidity range of 30% to 75%.

NOTE: *Do not install or use the unit in an area of high humidity, such as in the vicinity of a steam room, sauna, indoor pool or outdoors. Exposure to extensive water vapor, chlorine and/or bromine could adversely affect the electronics as well as other parts of the machine.*

Temperature - The unit is designed to function normally in an environment with an ambient temperature range of 50° F (10° C) to 104° F (40° C) degrees.

Storage

Humidity - The unit can be shipped and stored in an environment with a relative humidity range of 10% to 90%.

NOTE: *Do not store the unit in an area of high humidity, such as in the vicinity of a steam room, sauna, indoor pool or outdoors. Exposure to extensive water vapor, chlorine and/or bromine could adversely affect the electronics as well as other parts of the machine.*

Temperature - The unit can be shipped and stored in an environment with an ambient temperature range of 32° F (0° C) and 140° F (60° C) degrees.

This page intentionally left blank

6 - Service

Please refer to the next several pages for parts lists, exploded-view diagrams and cable and belt routing diagrams.



NOTE: All inspections and repairs must be performed by trained service personnel only.

Cybex will void warranty if non-Cybex replacement parts are used.

This page intentionally left blank.

CABLE COLUMN

PRODUCT NO. 12220

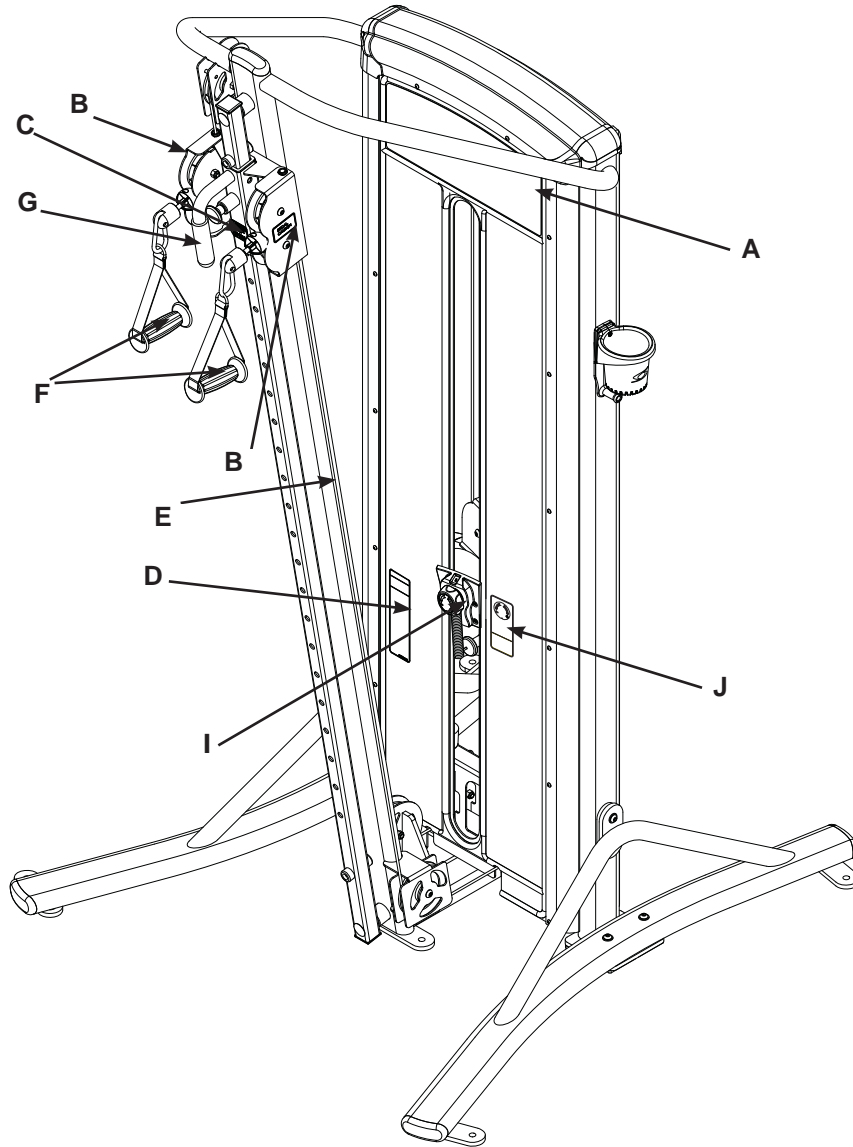

See exploded-view diagram for location of H (serial number decal).

DESCRIPTION	PART NO.	DESCRIPTION	PART NO.
A. Placard Decal	12220-598-X	F. Handle Assembly.....	12220-005
B. Caution Decal	4000Y316-X	G. Grip 4.75 Foam	4800-700
C. Caution Decal	8500-025-X	H. Serial Number Decal	
D. Warning Label	4605-381-X	I. Weight Selector Pin.....	BH030207
E. Cable Assembly.....	12220-002	J. Increment Weight Decal....	11000-407

Cybox VR3 12220 Cable Column Owner's Manual

ITEM	QTY	PART NO.	DESCRIPTION
1	8	08011	RETAINING RING (.625)
2	8	08014	PULLEY ASSEMBLY, 4.50 IN.
3	2	08135	BRG, BALL
4	1	08229	PIN,DETENT
5	1	11040-021	TOP WEIGHT ASSY 15
6	1	11040-440	KNOB
7	2	12000-388	EXTRUSION, INC WT CHANNEL
8	1	12000-395	TOP CAP
9	2	12000-396	END CAP
10	4	12000-398	SPACER
11	2	12000-402	CHANNEL, INCREMENT WEIGHT
12	1	12000-415	PANEL INSERT
13	5	12090-322	FOOT PAD
14	2	12102-330	INSERT, INCREMENT WEIGHT
15	2	12102-331	INSERT, INCREMENT WEIGHT
16	2	12210-347	GUIDE ROD CAP
17	2	12210-348	GUIDE ROD CAP
18	1	12220-002	CABLE ASSEMBLY
19	2	12220-005	HANDLE ASSEMBLY
20	1	12220-200	FRAME
21	1	12220-201	LEG LH
22	1	12220-202	LEG RH
23	1	12220-205	CAM BOLT
24	1	12220-212	ADJUSTING HANDLE
25	2	12220-313	PLATE, PULLEY
26	2	12220-321	PULLEY PLATE
27	2	12220-326	WT ROD .625 DIA.
28	4	12220-336	BUSHING
29	1	12220-355	TUBE, DETENT
30	4	12220-358	SPACER
31	6	4400-354	PULLEY, 3.50 INCH
32	1	4605-512	INSERT PLASTIC, 7.94
33	1	4800-700	GRIP, 4.75 FOAM
34	1	5649-314	DECAL, ADJUSTING
35	1	9100-313	DECAL, WEIGHT PLATE 1 - 25
36	2	AH020000	SWIVEL HOUSING
37	2	BR030224	RETAINING RING, 1.188 INTERNAL
38	1	BS070201	COM SPRING .56 x .66 1.50 LG
39	2	BS070208	COMPRESSION SPRING
40	1	CM000211	DECAL, PATENT PENDING

ITEM	QTY	PART NO.	DESCRIPTION
41	4	FB130205	BRG,FLG .62 x .75 .38 LG
42	2	GQ000206	SNAP LINK
43	2	HC620428	BHSCS .250-20 X 2.25
44	2	HC700415	BHSCS .375-16 X .75
45	1	HC700432	BHSCS .375-16 X 2.75
46	14	HF579000	PANEL FASTNER, 10-24 U TYPE
47	4	HM580410	BHSCS .190 10-32 X .375
48	2	HN624100	HEX NUT .250-20
49	4	HN-60560	NUT, NYLOCK .375-16 BLK ZINC
50	4	HN704400	NUT, HEX JAM .375-16
51	9	HN704901	LOCKNUT, .375-16 NYLON
52	2	HP346717	ROLL PIN .375 X 1.00
53	17	HS347600	WASHER, SAE .375
54	4	HS-60531	BOLT, BHSC .375-16 x .75 BLK ZINC
55	8	HS-60536	BOLT, BHSC .375-16 x 2.00 BLK ZINC
56	10	HT512517	TAP SC 10-24 X 1.00 TYPE WB PN
		HD PHIL BLK	
57	14	HX570412	BHSCS, 10-24 X .50, SS
58	7	JC700424	BHSCS .375-16 X 1.75
59	8	JS407100	BUSHING .625 MACHINERY
60	2	PN660200	INSERT, PLASTIC 1.00 DIA-11 GA
61	4	PP040004	BALL STOP
62	2	PP090211	INSERT, PL 1.50 SQ X 10-14 GA
63	5	PP130002	INSERT, DOMED PLASTIC
64	2	PR060005	BUMPER, WEIGHT
65	4	PR069400	BUMPER, RECESS
66	4	PR070004	FOOT PAD, 3.00 x 5.00
67	1	12220-999-X*	OWNER'S MANUAL (NOT SHOWN)
68	2	4000Y316-X*	DECAL, CAUTION
69	1	8500-025-X*	DECAL, CAUTION
70	1	4605-381-X*	DECAL, WARNING
71	8	HW-60085	WASHER, USS .312 BLK ZINC
72	1	12220-598-X*	PLACARD VR3 CABLE COLUMN
73	1	11000-407-X*	DECAL, INCREMENT WEIGHT
74	1	13000-402	WATER BOTTLE HOLDER MOUNT
75	1	13000-400	WATER BOTTLE HOLDER
76	1	HT552515	TAP SCREW 8-16 X .75
77	1	11040-790	DECAL, MADE IN U.S.A.

***Language Key**

1-German
2-French
3-Spanish
4-English
6-Japanese
7-Swedish
8-Russian

MAIN ASSEMBLY DETAIL

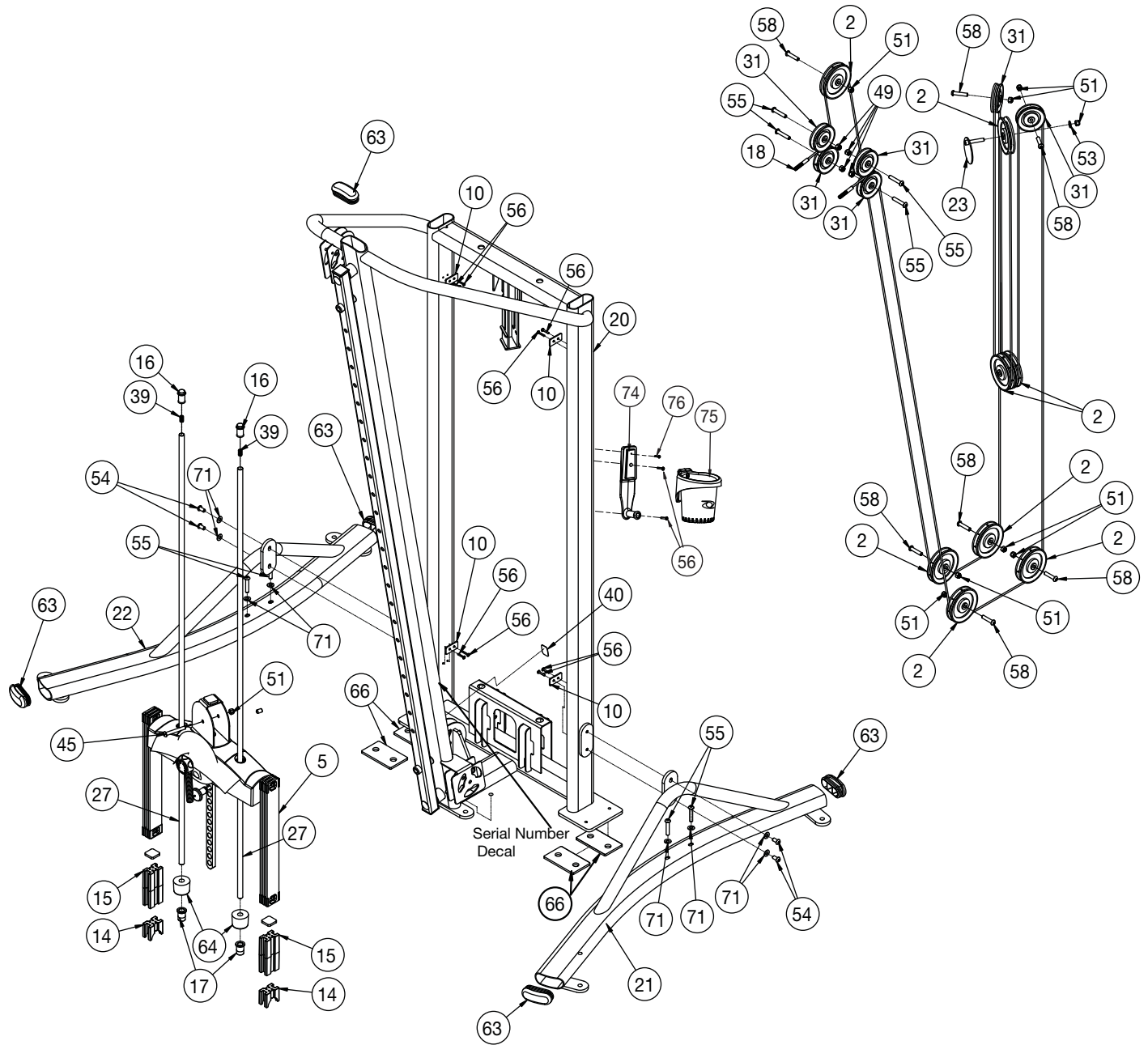

CARRIAGE COLUMN ASSEMBLY DETAIL

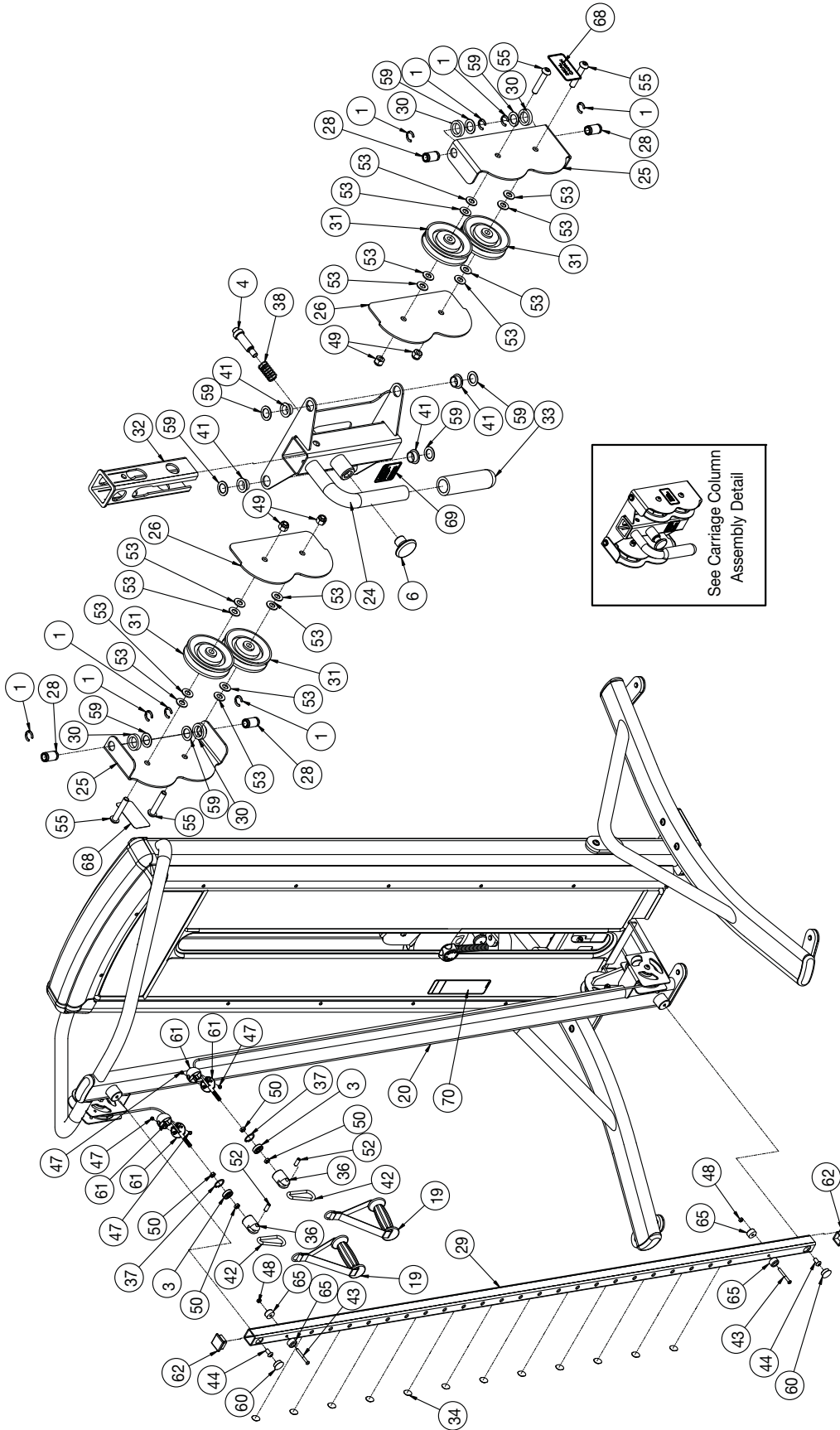

SHROUD ASSEMBLY DETAIL

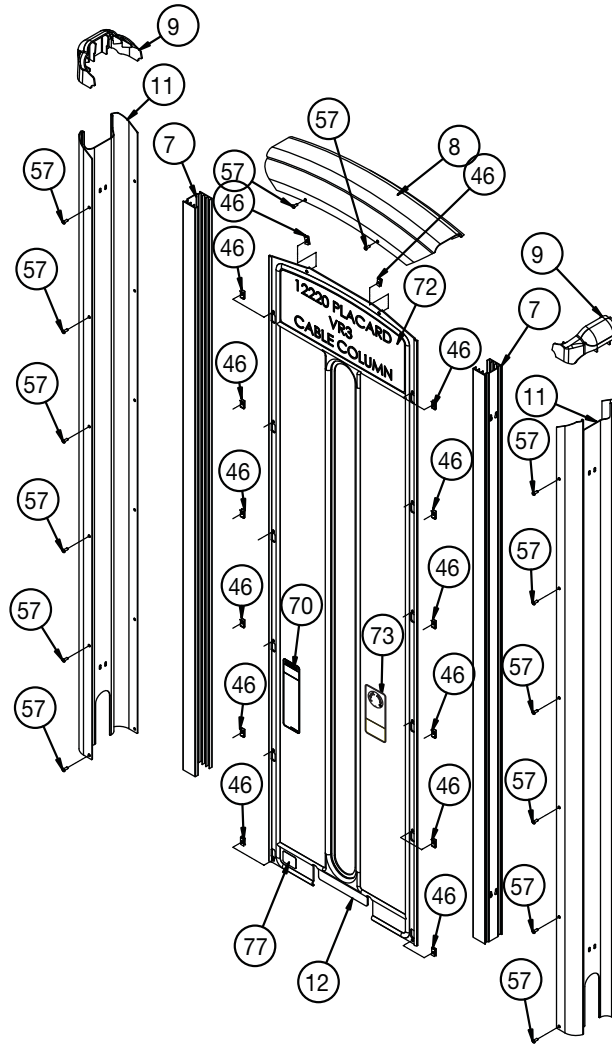

**Heavy Stack Assembly Configuration
12020-021**

ITEM	QTY	PART NO.	DESCRIPTION
1	1	12000-378	Support
2	1	12000-384	Panel, Insert
3	1	3900-441	Decal, Cyber
4	12	HF579000	Panel Fastner, 10-24 U Type
5	15	HX570412	BHSCS10-24 x 50 SS

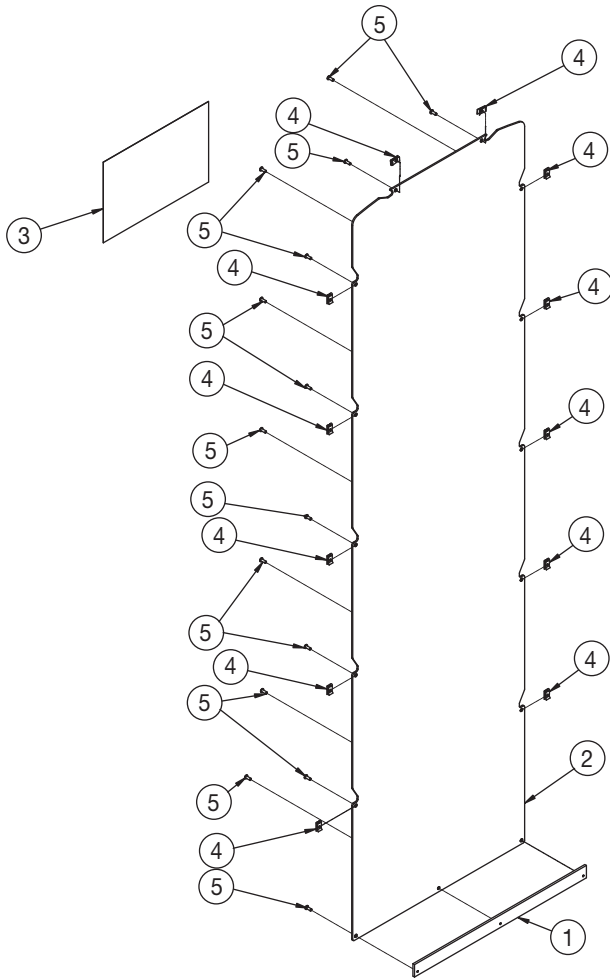

Top Weight Assembly

ITEM	QTY	PART NO.	DESCRIPTION
1	1	11040-366	TOP WT ASSY, MOLDED
2	1	11040-367	HUB, MOLDED
3	2	11040-369	ROD, LINKAGE
4	2	11040-370	PIN
5	3	11040-409	MOLDED BUMPER PAD
6	1	11040-416	COVER, TOP WEIGHT
7	1	11040-424	COVER PLATE
8	1	11040-425	KNOB
9	1	11040-426	STEM
10	1	11040-427	ROD
11	1	11040-428	ADJUSTMENT DECAL
12	1	11040-429	ROTATION DECAL
13	12	11040-572	GUARD, INCREMENT
WEIGHT			

ITEM	QTY	PART NO.	DESCRIPTION
15	1	12220-208	PULLEY TAB
16	1	4700-251	LIFTING POST 15
17	1	BH030207	PIN, WEIGHT SELECTOR
18	4	BR030209	RETAINING RING .188 EXTERNAL
19	2	BR030220	RETAINING RING 1.250 INTERNAL
20	1	HP016820	COTTER PIN .125 X 1.25
21	1	HP266765	ROLL PIN, .125 X .938
22	2	HS720004	WASH, FELT .641 1.250 .125T
23	4	HT562715	TAP SC NO 10 X .750 F PHIL
24	1	HT552512	TAP SC NO. 8-16X .50 PN HD PHIL
25	4	HT582510	TAP SC NO 10 X .375 PN HD PHIL
26	1	HY740000	SET SCREW
27	14	4000C101	WEIGHT PLATE
28	1	4701-013	HEAVY WEIGHT PACK (NOT SHOWN)

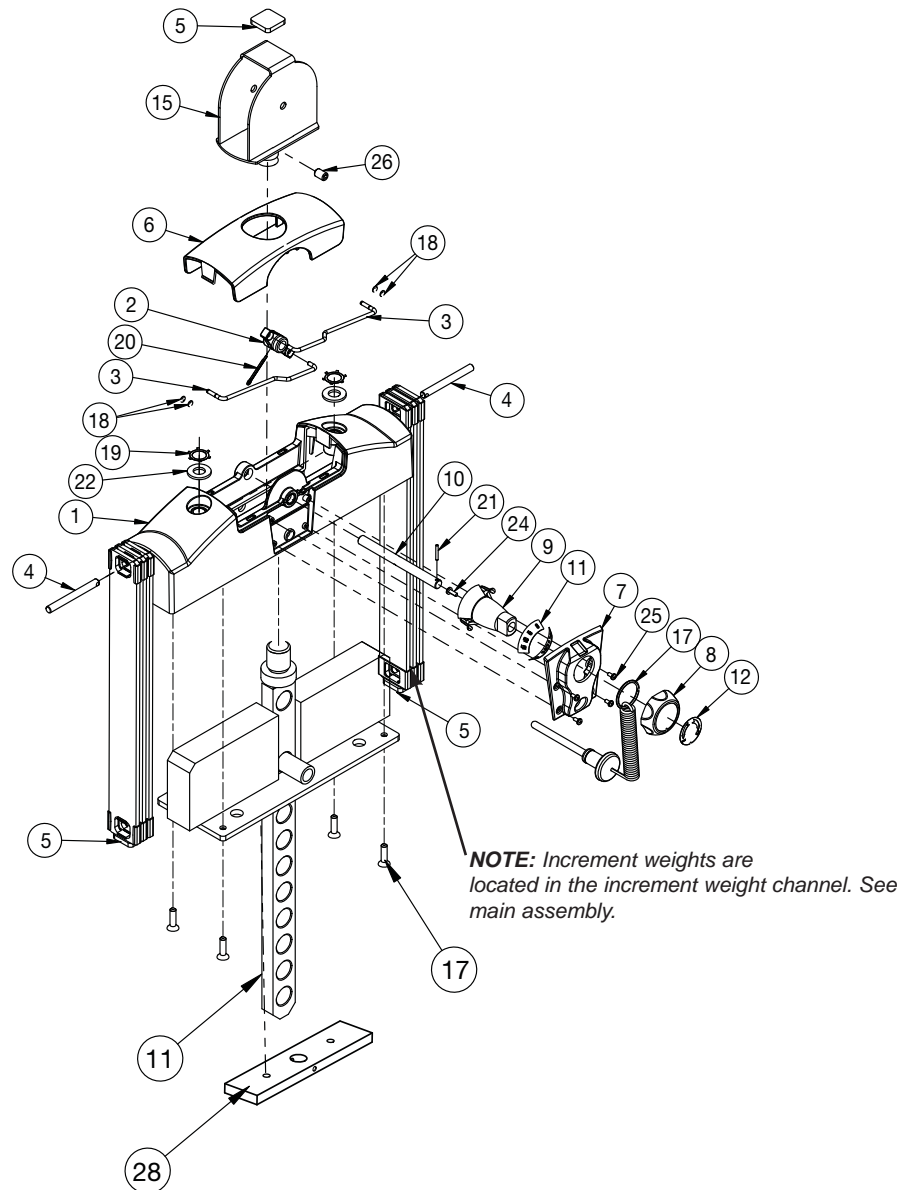

CABLE ROUTING DETAIL

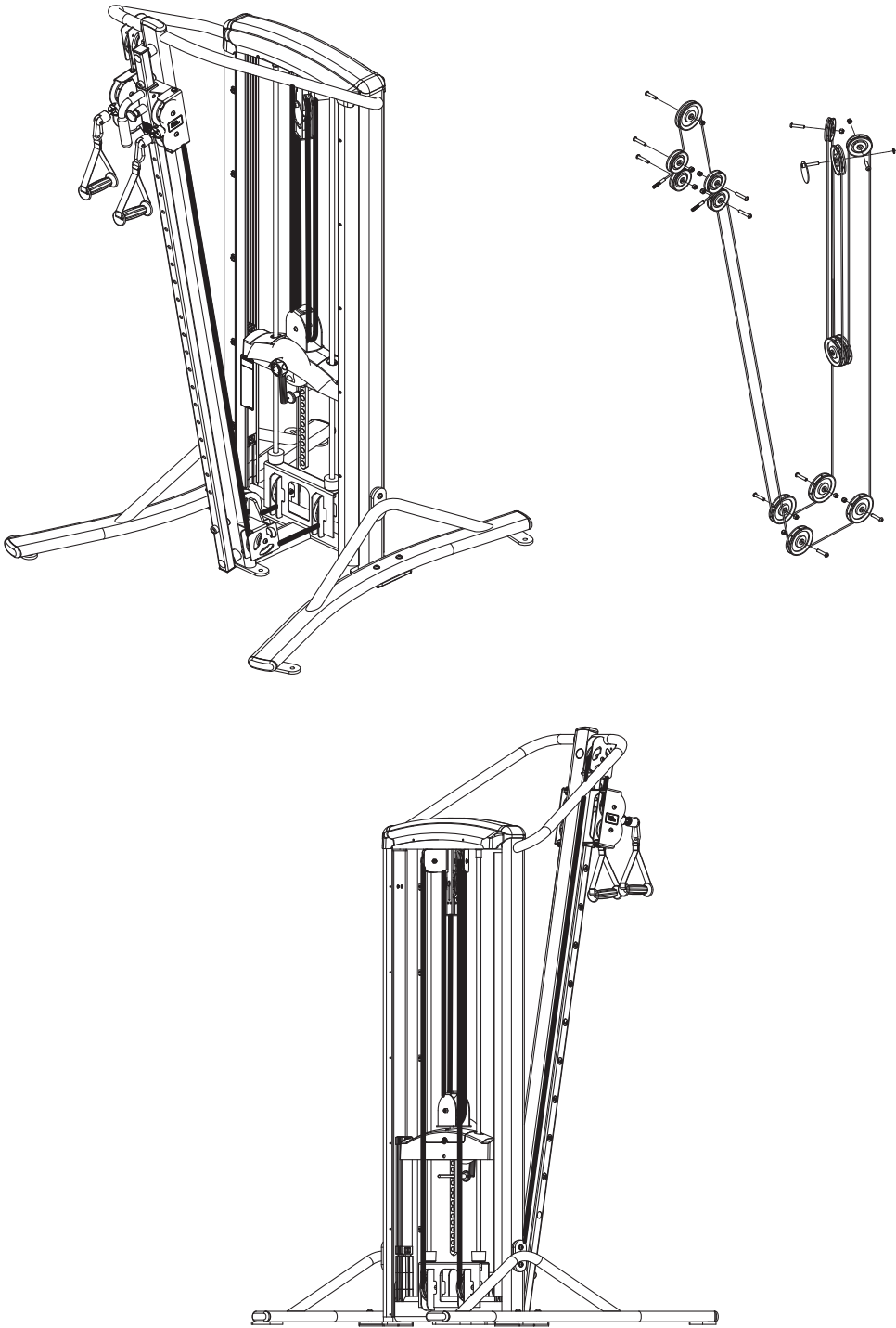



10 Trotter Drive Medway, MA 02053 • 508-533-4300 • FAX 508-533-5183
www.cybexinternational.com • techhelp@cybexintl.com