

SCOTTSMAN[®]

SERVICE MANUAL

MF 82

Modular superflakers

TO BE USED JUST
BY THE INSTALLER

TABLE OF CONTENTS		page	
	Table of contents		3
	Specifications		4-5
Section I	GENERAL INFORMATION AND INSTALLATION		
	Introduction		6
	Description		6
	Sealed refrigerant system		6
	Storage bin or ice room		6
	Unpacking and inspection		6
	Location and levelling		7
	Electrical connection		7
	Water supply and drain connection		7
	Remote condenser and pre-charged line		8
	Final check list		9
	Installation practice		10-11
Section II	OPERATING INSTRUCTIONS		
	Pre-start inspection		12
	Start up		12
Section III	PRINCIPLES OF OPERATION - HOW IT WORKS		
	ICE MAKER		14
	Water		14
	Ice		14
	Refrigeration		14
	ELECTRICAL/REFRIGERATION		15-16
Section IV	ADJUSTMENT, REMOVAL & REPLACEMENT PROCEDURES		17-18-19-20-21
Section V	SERVICE DIAGNOSIS		22-23
Section VI	WIRING DIAGRAMS		24-25-26
Section VII	MAINTENANCE AND CLEANING INSTRUCTIONS		27-28

SPECIFICATIONS

MF 82 - AIR & WATER COOLED MODEL

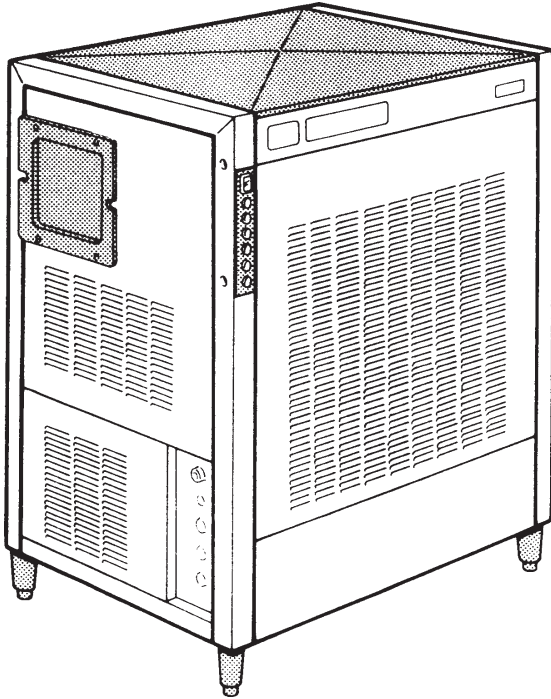

Important operating requirements:

	<u>MINIMUM</u>	<u>MAXIMUM</u>
• Air temperature	10°C (50°F)	38°C (100°F)
• Water temperature	5°C (40°F)	38°C (100°F)
• Water pressures	1, 5 atm (20 lbs) gauge	
• Electrical voltage variation	voltage rating specified on nameplate	
	-10%	+10%

Extended periods of operation exceeding these limitations constitutes misuse under the terms of Scotsman Manufacturer's Limited Warranty, resulting in a loss of warranty coverage. We reserve the right to make product improvement at any time. Specifications and design are subject to change without notice.

ice making capacity

AIR COOLED MODELS

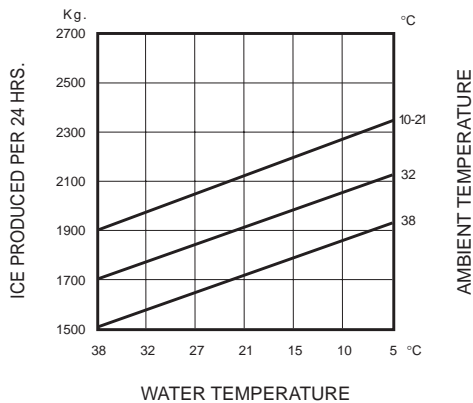

WATER COOLED MODELS

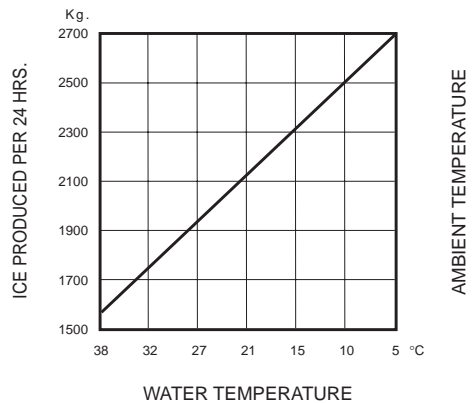

NOTE. Daily ice capacity is directly related to condenser air and water inlet temperature, water temperature to make ice - and age of machine. To keep your MF 82 performing at its maximum capacity it is necessary to perform periodic maintenance as outlined on page 27 of this manual.

SPECIFICATIONS (CONT'D)

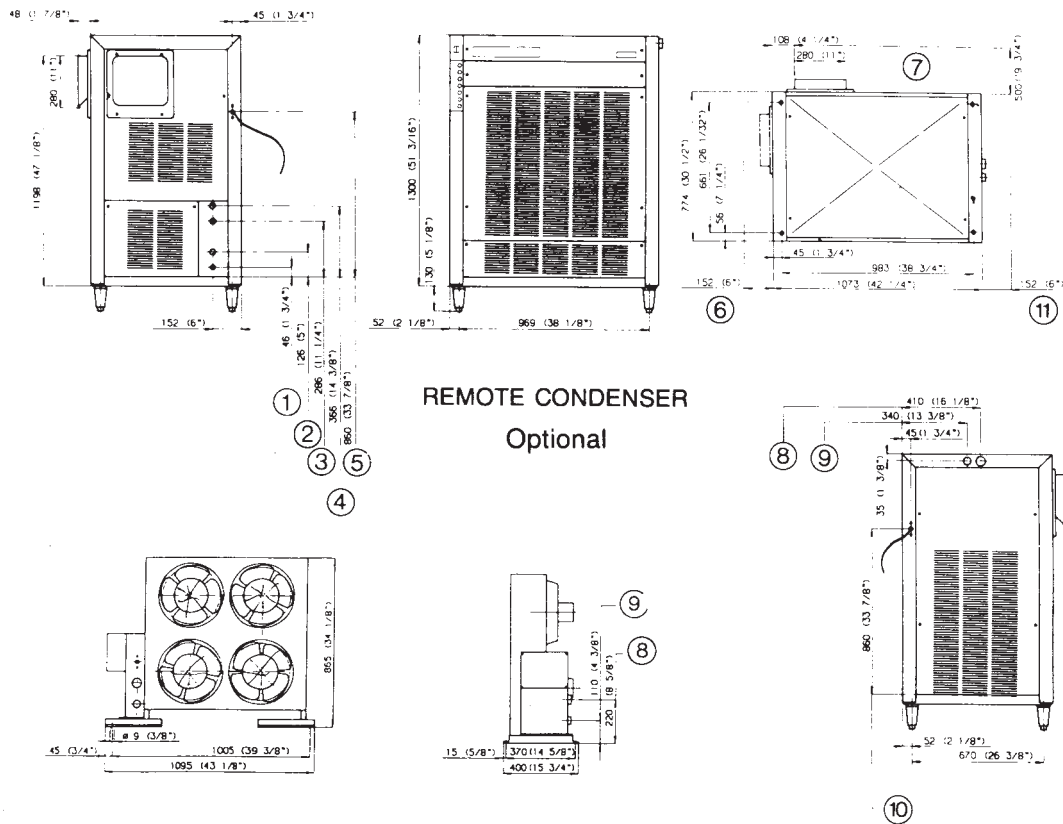

REMOTE CONDENSER
Optional

- ① WATER OUTLET
- ② WATER OUTLET - WATER COOLED ONLY
- ③ WATER INLET - WATER COOLED ONLY
- √ WATER INLET
- ⑤ CORD SET
- ≈ MIN SPACE FOR CONNECTION
- △ MIN SPACE FOR PROPER VENTILATION
- ⑧ GAS LINE CONNECTION
- ⑨ LIQUID LINE CONNECTION
- ⑩ CORDSET - REMOTE CONDENSER
- ⑪ MIN SPACE FOR CONNECTIONS

Dimensions:

HEIGHT: 1300 mm (51-1/4")
 WIDTH: 1073 mm (42-1/4")
 DEPTH: 774 mm (30-1/2")
 NET WEIGHT: 407 Kg - MF 82 - A
 387 Kg - MF 82 - W

MF 82 FLAKER - MACHINE SPECIFICATIONS

Model	Cond. unit	Finish	Compr. HP	Water req. lt/24 HR
MF 82 AS MF 82 WS	Air Water	Stainless Steel	5	2400 26500*
Basic electr.	Amps	Refr.	Electric power cons. Kwh per 24 HR	Nr. of wires
Air Cooled 230/50/3+N 400/50/3+N	*** 17	R 404 A	170	*** 5 x 2.5 m/m ²
Water Cooled 230/50/3+N 400/50/3+N	*** 14	R 404 A		*** 5 x 2.5 m/m ²

* At 15°C (60°F) water temperature

SECTION I

GENERAL INFORMATION & INSTALLATION

INTRODUCTION

This manual provides the specifications and the step-by-step procedures for the installation, start-up, operation and maintenance and cleaning of the SCOTSMAN Model MF 82 Flaker.

The Model MF 82 is a quality designed, engineered, constructed and thoroughly tested icemaking system, providing the utmost in flexibility to fit the needs of a particular user.

DESCRIPTION

The Scotsman MF 82 - continuous flow ice maker - consists of one large capacity flake ice making system contained within a compact cabinet which can be in enamel finish or entirely in stainless steel. The flake ice produced is extruded through an ice discharge opening provided in the rear side of the unit. If the unit location requires it, the ice spout can be positioned, as well, to discharge the ice out through a second opening provided in the left side of the cabinet. All panels are removable to allow easy access to electrical and mechanical components for cleaning and maintenance.

SEALED REFRIGERANT SYSTEM

To provide quite efficient operation of the ice maker, the compressor is mounted on rubber grommets. The water cooled models have a tube within a tube condenser with water regulating valve for correct condensing water flow.

The air cooled model has a built-in condenser with four fan motors, controlled by two pressure controls. The freezer auger is driven by a gear motor assy.

The refrigerant used is R 404 A controlled by an automatic expansion valve.

On request the MF 82 cal also be supplied with remote condenser and copper refrigerant lines.

STORAGE BIN OR ICE ROOM

Since the MF 82 is a continuous flow type ice maker and does not have its own attached storage bin, it is necessary to use an auxiliary bin or prefabricated ice room for appropriate ice storage. An insulated ice storage bin or room is always required, then - according to ice applications - this can be refrigerated or non-refrigerated; a weight/volume ratio of 1,8 m³ per ton must be taken into consideration for correct ice storage room design which, in any case, should be dimensioned to accommodate a minimum of 16 hrs. ice production.

UNPACKING AND INSPECTION

1. Call your authorized SCOTSMAN Distributor or Dealer, for proper installation.

2. Visually inspect the exterior of the shipping container and skid and any severe damage noted, should be reported to the delivering carrier; and, a concealed damage claim filled in subject to internal inspection, with carrier representative present.

3. Remove the packing, and remove the shipping bolts and the shipping base or skid.

4. When necessary, install the leg levelers in the cabinet base sockets; then, raise the cabinet to the upright position.

5. Remove screws and shipping tape, and all doors and service panels from the cabinet, and inspect for any concealed damage. Notify carrier of any concealed damage claims, as stated in step 2 above.

6. Remove all internal support packing, tape and wires in machinery compartment.

7. Check that refrigerant lines do not rub or touch lines or other surfaces, and that fan blades, if any, move freely.

8. Check that the Compressor is snug on all mounting pads.

9. Use clean damp cloth or disposable paper wiper to pipe clean the exterior surfaces of the cabinets.

10. See DATAPLATE on the cabinet base and check that the location source voltage corresponds with the voltage specified on the dateplate.

CAUTION. Unproper voltage supplied to the ice Maker will void your parts replacement program.

11. Remove the Manufacturer's Registration Card from the User Manual and fill in all spaces including: Model Number and Serial Number taken from the aluminium plate. Forward the completed, self addressed, registration card to the Frimont Factory.

LOCATION AND LEVELLING

WARNING. This unit must be installed in an area where it will not freeze and protected from the elements such as wind, rain, water spray or drip. Ambient temperature limitations are: 10°C (50°F) minimum and 38°C (100°F) maximum, while water temperature limitation are: 5°C (40°F) minimum and 38°C (100°F) maximum. Ambient and water temperature exceeding these limitations may result in machine malfunction and the loss of warranty coverage.

Make sure that the structure on which the ice maker will be located be on a solid footing and supports at least 1000 Kgs.

This ice maker is designed for free standing application only. Do not built it in. Make sure that location site is well ventilated to ensure correct operation of air-cooled models that have the condenser directly behind the front panel. Also allow 20 cm clearance in back and both side of the ice maker to be able to easily perform service inspections and operations.

1. Erection - For elevation of machine to its stand or location, chain falls or fork lifttrucks should be used. Chain falls can be hooker up to the machine for upper corners holes provided for this sort of operation.

2. Position the MF 82 in the selected permanent location and level the cabinet on both the left-to-right and front-to-rear direction.

3. Ice chute extension or ice deflector - if not pre-set - must be arranged to convey the ice from the outlet of the machine to the ice storage area. Stainless steel is an excellent material where its cost is not prohibitive. Angles or edges of less than 45° should not be used. Ice will cling to the surface and either melt excessively or jam in the ice chute. The sharper the drop, the better. If straight down, do not insulate unless necessary. Ice chute and or ice deflector end - whenever possible - should be preset with grommated holes so that bin thermostat capillary tube can be inserted in them to be correctly positioned.

4. Thermostat capillary tube must be positioned so that its end extends out the ice chute opening or the ice deflector and get easily in contact with the cone formed by the ice deposited in the storage room, before - anyway - that ice builds-up in the chute.

Thermostat capillary tube is coiled behind the control box, it must be routed to follow the ice chute or ice deflector and protrude for a certain extension beyond the ice discharge opening in the storage room. Use caution when routing this capillary to prevent kink or to bent it excessively. Coil excess capillary inside ice maker cabinet. Tape coil to prevent vibration against another part.

ELECTRICAL CONNECTION

See machine electrical specifications in Unit Nameplate and at page 3 of this Service Manual to determine wire size to be used for electrical supply. This unit must be grounded according to all Electrical Codes and local ordinances. Provide a fuse disconnect box within sight and easy-reach of the ice maker. Use delayed action fuses on all terminals.

The maximum allowable voltage variations should not exceed ten percent of the nameplate rating, even under starting conditions. Low voltages can cause erratic operation and may be responsible for serious damages to the overload switch and motor winding.

WARNING. The compressor is equipped with a crankcase heater which has to be energized even when the ice maker is switched-off. So, make sure to connect the unit with the compressor crankcase heater constantly energized. After long inoperative periods remember to give current to the heater 4 hours before the ice maker start-up.

WATER SUPPLY AND DRAIN CONNECTIONS

A. AIR-COOLED MODELS: The recommended water supply line is a 3/4 inch O.D. fitting. Connect to cold water supply line with standard plumbing fittings, with a shutoff valve installed in an accessible place between the water supply and the Cabinet.

A wire mesh strainer is provided inside the fitting. The strainer protects against large particles of rust, scale, etc., which may be loosened in the water supply pipe at the time of installation. In some cases, a plumbing permit and services of a licensed plumber will be required.

CAUTION - This ice maker is equipped with a low water pressure safety device which, in the event of low water pressure, will automatically stop the ice maker to prevent damage. The ice maker will automatically restart with increased water pressure. This ice maker will not operate properly when water supply temperatures are below 5°C (40°F) and above 40°C (100°F).

B. WATER-COOLED MODELS: On Water-Cooled models a separate connection, to the Condenser is required. A 3/4 inch O.D. fitting is provided for a separate water inlet line to be connected and a separate drain line to be connected.

NOTE. - *The WARNING, in the text above for the Air-Cooled models equally applies for the Water-Cooled models. In both type installations, water supply must be installed to conform with local plumbing codes. In some cases, a plumbing permit and services of a licensed plumber will be required.*

C. DRAIN CONNECTIONS: All drains are gravity type and must be 1/4-inch per foot on horizontal runs. The drains to be installed to conform with local code. The drain receptacle should be an open, trapped or vented construction. Connect a drain line to 3/4-inch I.D. tube from the freezer drip pan and a separate drain line to 3/4-inch O.D. drain fitting from the Water-Cooled Condenser, on Water-Cooled models.

REMOTE CONDENSER AND PRECHARGED REFRIGERANT LINES INSTALLATION

A. Location considerations:

1. Limited to 6 metres the length of precharged refrigerant line from the left side of the icemaker to the remote condenser.
2. Maximum vertical rise of 3 metres between the icemaker and the remote condenser;
3. Best available location, protected from the extremes of dirt, dust, rain, sun and winds.

B. Unpacking and inspection:

1. Visually inspect the exterior of the shipping container and any severe damage noted, should be reported to delivering carrier; and a concealed damage claim filled subject to internal inspection, with carrier representative present.
2. Uncrate the remote condenser and precharged refrigerant line and inspect for any concealed damage. Notify carrier of any concealed damage claims, as stated in step 1, above.
3. Check that the pre-charged refrigerant lines are intact, not kinked, and that there is no sealed puncture or loss of refrigerant.

C. Remote condenser - wall attachment:

1. Install and attach the remote condenser to the wall of the building, using the methods and

practices of building standards that conforms to and meets the local building code requirements, in your area.

2. Remove control box cover from remote condenser and connect the electrical power line coming from the unit to the wires of the fan motor by means of the connecting terminal board placed into the control box following the wires color fitted on the same.

D. Pre-charged refrigerant lines

1. The set of pre-charged refrigerant lines consists of a 3/8 inch inside diameter, self-sealing liquid line and a 3/4-inch inside diameter, self-sealing discharge line.
2. When possible, route the maximum length of the pre-charged refrigerant lines in the building, with the minimum length outside, to prevent vandalism and to minimize the condenser effect that exposed lines can produce in cold weather. Insulate lines that will be exposed to outside temperatures that will be below freezing, for extended periods of time.

CAUTION

1. Each coupling on the precharged refrigerant lines, is self-sealing and should be tightened 1/4 - turn more than snug tight. ALWAYS USE TWO WRENCHES WHEN TIGHTENING THESE FITTINGS, ONE AS BACKUP WRENCH TO PREVENT TWISTING OF TUBING AND POSSIBLE KINKING OR LINE RUPTURE.

3. Connect the 3/8-inch diameter refrigerant line coupling, to the remote condenser refrigerant fitting and to the refrigerant fitting on the right side of the Icemaker chassis.
4. Connect the 3/4-inch diameter refrigerant line coupling, to the remote condenser refrigerant fitting and to the refrigerant fitting on the right side of the Icemaker chassis.

E. Excess length of pre-charged refrigerant lines: at installations where the Icemaker chassis - to - remote condenser refrigerant line path is substantially less than the length of pre-charged refrigerant lines to be installed, route and dress the excess refrigerant line as follows.

1. Follow straight line routing, when possible.
2. Retain excess pre-charged refrigerant line inside the building.

3. Spiral the excess length of the precharged refrigerant line, in the best selected inside location, and in a manner that prevents refrigerant trapping.

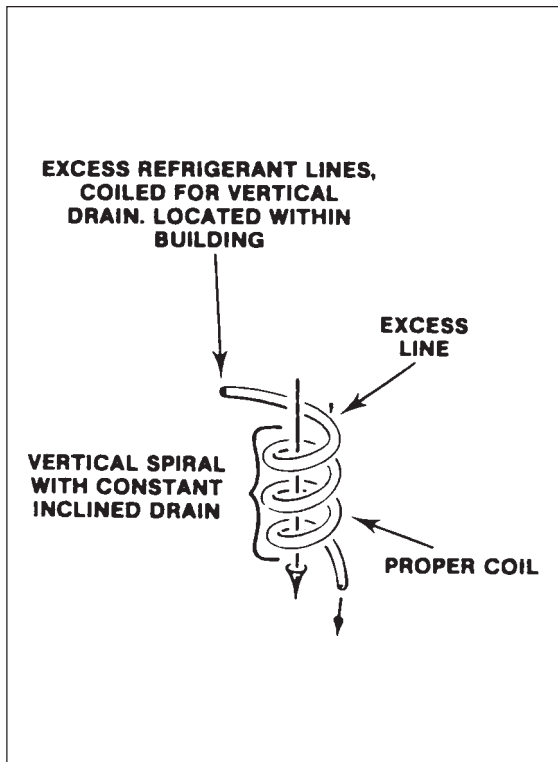

CAUTION - DO NOT kink or brimp the refrigerant lines. DO NOT bend the excess refrigerant lines in a vertical loop(s), which allow trapping of refrigerant in LOW sections, during OFF time. Bend and shape the excess refrigerant lines in VERTICAL spirals, not HORIZONTAL spirals. See Figure above.

FINAL CHECK LIST

1. Is the Cabinet level? (IMPORTANT)
2. Have all electrical and piping connections been made?
3. Is there an electrical service disconnect within sight of the installed machine?
Has the voltage been tested and checked against the nameplate rating?
4. Is the water supply line shutoff valve installed near the machine.
5. Have all the wires been checked for looseness and tightness.
6. Have the Compressor hold down nuts been checked, to be sure the Compressor is snug on the mounting pads.
7. Has the owner/user been instructed on how to operate the Icemaker.
8. Has the Manufacturer's registration Card been properly filled out? Check for correct Model and serial numbers from Serial nameplate, then mail the completed card to the FRIMONT factory.
9. Check all refrigerant line and conduit lines, to guard against vibration or rubbing and possible failure.
10. Is there at least 20 cm. clearance behind and around Cabinet for proper air circulation?
11. Is the Icemaker installed indoor in a location where ambient temperatures are a Minimum of 10°C (50-degrees F.) all year around?
12. Has water supply pressure been checked to insure a minimum of 1 atm (14 Psi).
13. Is the remote condenser installed per local building codes, and in a place where it has adequate ventilation and minimal solar heat gain.
14. Verify that unit lighted switch is in the OFF position.
15. Switch the main disconnect switch on power line in the ON position to energize the compressor crankcase heater well in advance the start-up.
16. Verify that dial of delay timer, in control box, is set on 5 minutes.
17. Has the owner been given name and telephone number of the authorized SCOTSMAN Service Agency

INSTALLATION PRACTICE

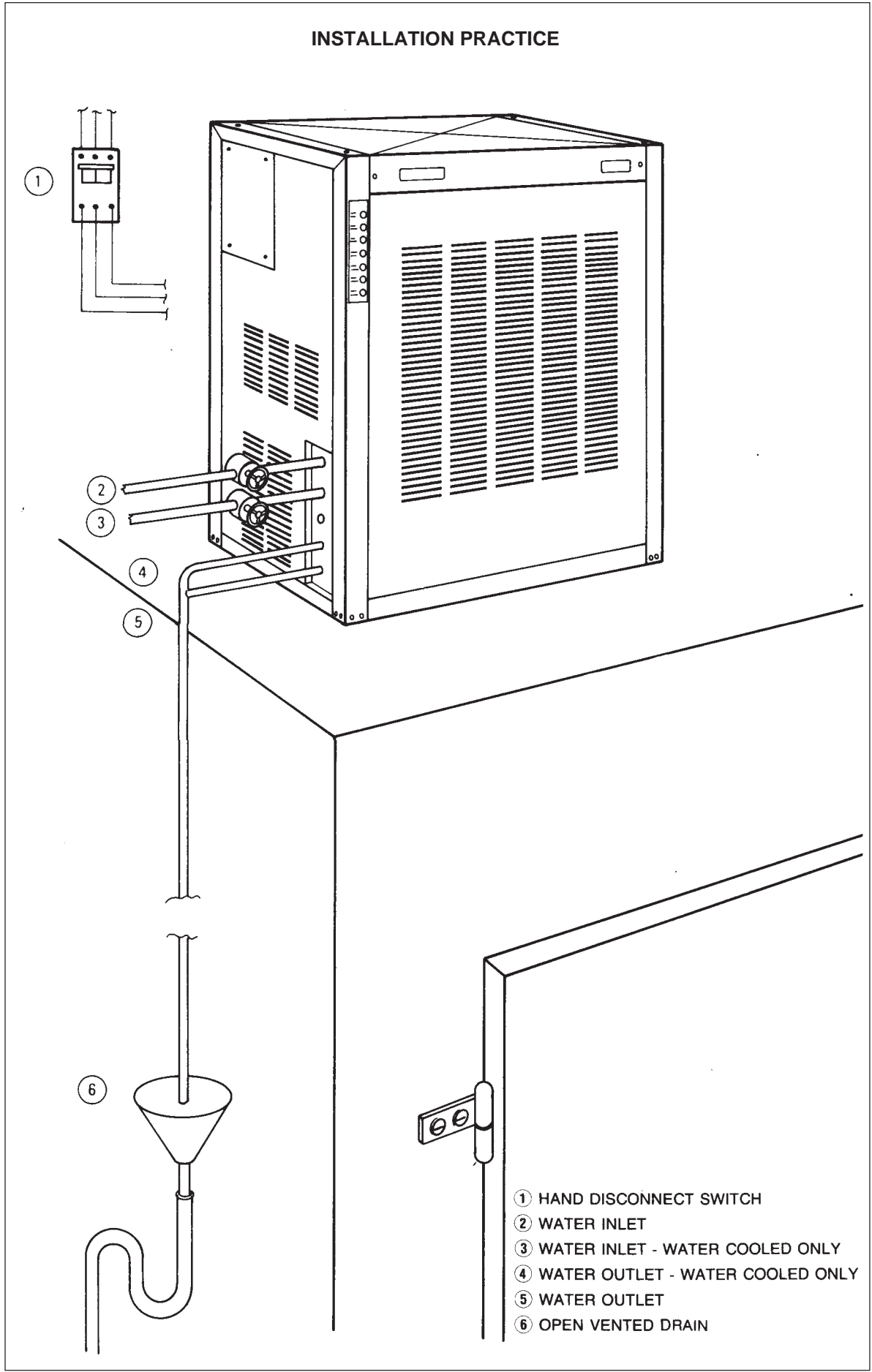

INSTALLATION PRACTICE

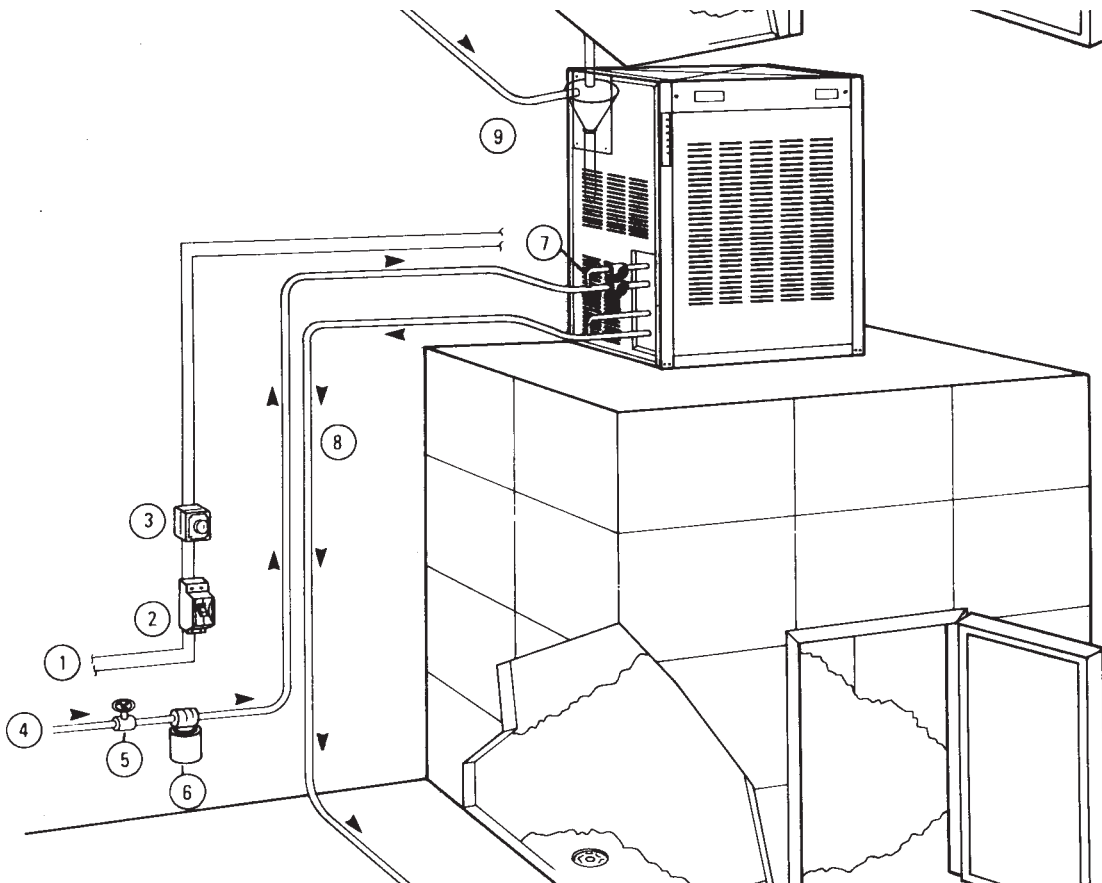

- ① POWER LINE
- ② HAND DISCONNECT SWITCH
- ③ CONTROL TIMER (OPTIONAL)
- √ WATER SUPPLY LINE
- ⑤ HAND SHUT - OFF VALVE
- ≈ WATER FILTER (NOT SUPPLIED)

- Δ WATER INLET LINE W / SEPARATE SHUT - OFF VALVES
- ⑧ WATER DRAIN LINE
- ⑨ OPEN VENTED DRAIN

SECTION II

OPERATING INSTRUCTIONS

PRE-START INSPECTION

1. Make sure that the electrical power has been on for at least 4 hours and that compressor crankcase is warm.
2. From unit left side check to see, through appropriate sight glass, the oil level in gear box and also the oil level in compressor crankcase.
3. Verify that drive motor current limiter LOVATO LA3E, located in control box on right side of contactor, has the AMPs setting knob (top red knob) positioned on 0.4 the second red setting screw on two sec. and the blue setting screw on zero INHIBITION setting.

START-UP

The following procedure can only be started after pre-start inspection has been properly completed.

1. Open the water supply line shutoff valve. Observe that water enters the water reservoir, fills the tube from the reservoir to the evaporator and then shut-off. Check for leaks.
2. Temporary set dial of delay timer to zero position.
3. Press unit lighted switch to ON. Unit will start operating. Verify immediately if auger drive motor turns the auger (coupling) in counterclockwise directions.

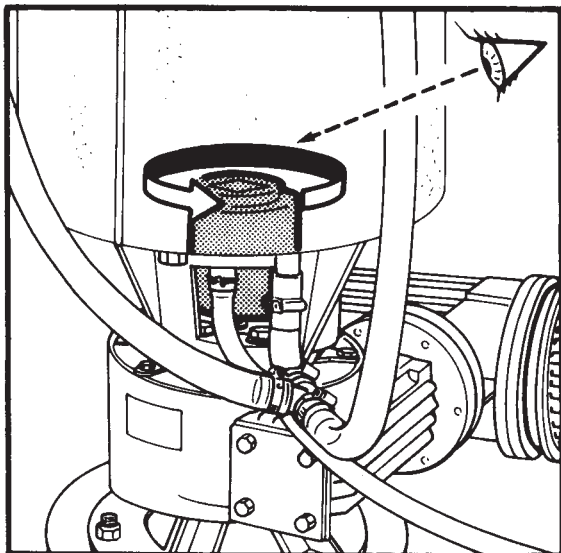

WARNING - The evaporator auger drive motor is threephase, so, at the unit start-up, care must be taken to ensure of the correct rotation direction of auger. In case of wrong rotation interchange the phases by interchanging the lead wire connections of main cord. AUGER MUST TURN COUNTER-CLOCKWISE.

4. If auger drive motor is rotating correctly, move the timer delay to 5 minutes position. Unit must be on delay control set on 5 min. and will always resume operation when 5 min. delay is elapsed.
5. After two or three minutes of unit operation observe that flaked ice begins to drop out in the ice spout. In the event that the drive motor current limiter will cut-out unit operation, DO NOT BE ALARMED. Unit will automatically resume operation after 5 minutes.
6. Let the system operate for about 30 minutes. Check for any excess noises beyond normal compressor noise:
 - a) Fan noises when Air-Cooled: blades touch other surfaces; blades bent; out of balance.
 - b) Vibrating type from touching lines.
 - c) Chattering: lack of water in Freezer.
 - d) Compressor loose at one or more hold-down bolts.
7. If desired, the low side pressure can be checked, it should be 1.9 atm (27 psi). Check to see through liquid sight glass for correct refrigerant flow and charge.
8. Hold a handful of ice around the ice storage bin thermostatic control bulb to test shut-off. Less than one minute is about normal for bulb shut-off function to cause the ice maker to stop. Remember that unit will resume operation after 5 minutes that bin thermostat has closed its contacts.

NOTE. When unit is on 5 minutes delay, the light of unit switch glows, signalling that unit is under power.

9. There are no adjustments to make, so replace the panels.

10. Thoroughly explain the owner/user the significant specifications of the ice maker, the start-up, operation and attention to pay going through the procedures in the operating instructions. Answer all questions about the ice maker, by the owner, and inform the owner of the name and telephone number of the authorized SCOTSMAN Service Agency serving him.

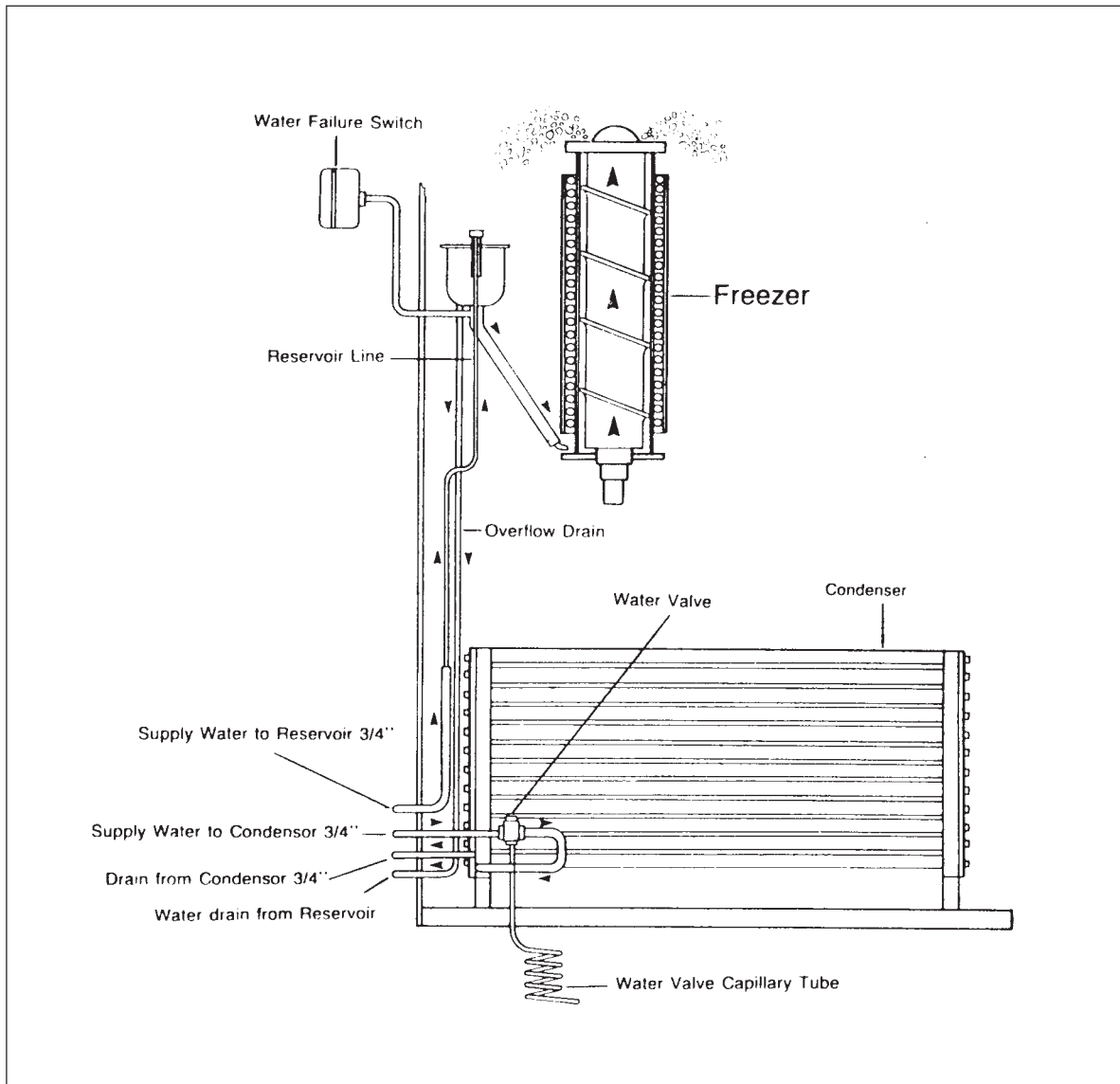

SECTION III

PRINCIPLES OF OPERATION - How it Works

ICEMAKER:

Water

The water supply flows from the building source through the inline water strainer, enters at the Cabinet fitting and on to the Water Reservoir. The water Reservoir functions to maintain a constant water level inside the Freezer Assembly. Water from the Water Reservoir enters at the bottom of the freezer Assembly and is changed into ice by low temperatures inside the freezer.

Ice

A stainless steel Auger within the Freezer is powered by a separate drive motor through a speed reducer and the rotating Auger carries the ice upward to the Ice Breaker assy where excess water is pressed out of the ice, as it is extruded or flaked out through the Ice breaker. The flake ice into spout in diverted out through the ice discharge opening. Moving the manual

ON-OFF toggle switch, to the ON position starts after 5 minutes the automatic and continuous icemaking process. When the Ice touches the Thermostatic Control Bulb, the sensing bulb shuts off the icemaking process.

Refrigeration

Beginning at the compressor, the refrigerant R 404 A is compressed into a high temperature gas.

The discharge line directs this gas to the condenser. At the condenser (air or water cooled), the gas is cooled by either air or water and it then condenses into liquid.

This high pressure liquid then goes through the liquid line to the expansion valve. The expansion valve meters liquid refrigerant into the evaporator. At the evaporator, the refrigerant enters an area of relatively low pressure where it can easily "boil-off" or evaporate.

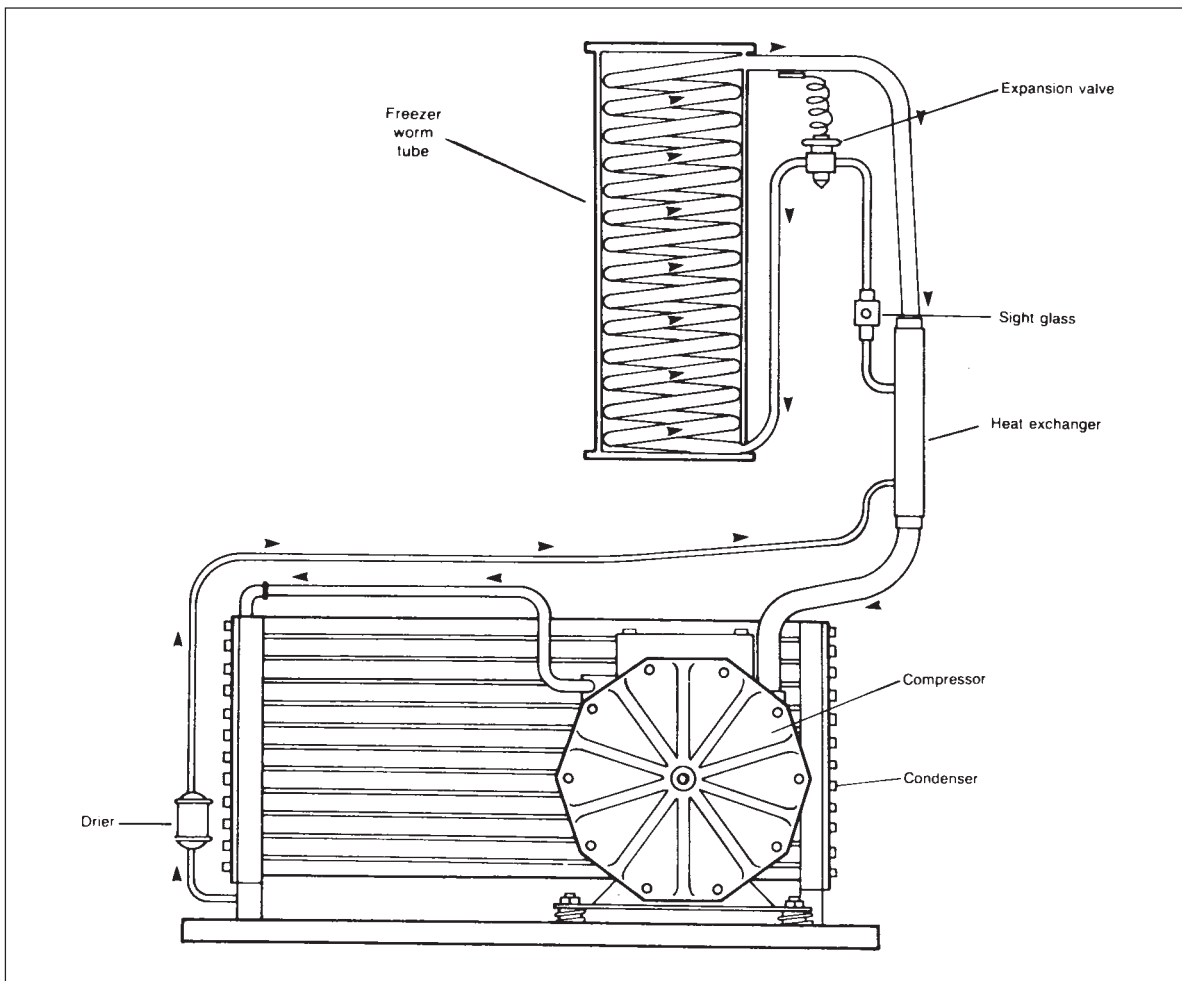

As it evaporates, it absorbs heat from the evaporator and whatever is in contact with it (such as the water inside it). After the evaporator, the refrigerant, now a low pressure vapor, goes through the heat exchanger and suction line back to compressor, where the cycle is repeated.

ELECTRICAL/REFRIGERATION

The MF 82 Flakers are designed to operate at 400 Volts. 50 Hertz, three-phase plus neutral. Special voltage requirements are available on special order.

Therefore, always CHECK NAMEPLATE for electrical information BEFORE proceeding with electrical wiring connections to the icemaker. Cold ambient temperatures and interruptions in water supply are conditions that can cause excessively hard ice and overloads within the Freezer Assembly, which is directly transmitted to the Drivemotor; and in turn, will cause the intervention of Drive Motor Current limiter.

Spout Switch is mounted on the top of the Ice Spout and is actuated by the movement of the spring retained pressure plate. The spout switch acts as a back-up safety switch, should the thermostatic Control Bulb fail and cause ice to jam-up in the ice spout. The switch will shut off the ice maker when actuated. The Spout Switch can be manually tested by pressing upward the pressure plate.

There are other five safety controls in the machine and are:

The low Pressure Control an automatic reset, adjustable control, set to electrically open at 0.2 atm (3 psi) to stop the entire ice maker, prevents operation at vacuum refrigerant pressures.

The low-water pressure Switch functions to discontinue the ice making process whenever incoming water pressure is reduced to below 0.8 atm (11 psi). The switch will automatically restart the icemaking process when the water pressure is increased to 1.2 atm (16 psi).

The manual Reset High head Pressure Control is factory set to stop the entire icemaker should the head pressure reach 30 atm (435 psi) on water cooled models and 34 atm (490 psi) on air cooled models.

The Time Delay Device (Timer) with setting dial from 0 to 10 min. It delays the energizing of main contactor in relation to its time setting, preventing short cyclings of units motor compressor and drive motor. It is factory set on 5' min. delay so - should power supply fail for an instant or should unit operation be interrupted by any safety control - ice machine will resume operation again after 5 minutes.

Drive Motor Current Limiter

It senses the intensity at the drive motor, should this exceed its Amps set point (2.5 Amps for 400 V units and 5.0 Amps for 230 V ones) cut-off power for an instant sufficient to trigger the Time Delay Device.

On water cooled models correct head pressure is **17 atm** (240 psi). Adjustments can be made on the Water regulation Valve.

Air cooled models MF 82 are equipped with two upper and lower fan motors. Both pair of motors are controlled by individual high pressure controls that are connected to the systems high side. The left fan control will not operate until high side pressure reach **16.5 atm** (230 psi). The right fan control will not operate until pressure reach **17 atm** (240 psi). This way, in colder ambients only the upper fan motors operate. In higher ambients the lower fans will cycle on/off. In extremely high ambients all four fan motors operate.

Suction pressure should be **1.9 atm** (27 psi) with proper refrigerant charge. When charging the system with refrigerant - on water cooled models - set the compressor head pressure at **17 atm** (240 psi) and charge with refrigerant so that the frost line extends out of the compressor at least eight inches after 15 minutes operation for best capacity and performance.

MF 82 REFRIGERANT CHARGE

MODEL

Air cooled	R 404A	4650 gr. approx.
Water cooled	R 404A	2200 gr. approx.

CONTROL CONSOLE

Located on the front panel is a virtual control console that monitors unit performance automatically. Any interruption or significant reduction in water or electrical supplies causes an instant stop to the operation of the modular flaker.

At the same time a warning light yellow or red is activated on the control console telling the user of the ice makers stoppage and also the reason why.

If the stoppage is caused by its refrigerant pressures or overloading in the drive train mechanism a warning light glows, the cause of the stoppage should be diagnosed and corrected before reoperating the ice makers corrected before reoperating the ice makers stoppage and also the reason why.

The warning light signals low or interrupted water supply. This light and its internal control are on an automatic reset device whereby the icemaker will automatically start up and the red light goes off when water pressure reaches 1.2 atm (16 Psi) or more.

Two other lights signal respectively Compressor Motor Overload and Bin Thermostat cut-out situation. Both these controls are automatic.

Besides the compressor that has important function to provide refrigerant to the evaporator to form ice, in the MF 82 flaker there are the following components that worth to be mentioned:

The Drive Motor Coel mod. F80B4 0.75 Kw Volts 230/380 Ph 3 Hz 50 Amps 2.9/1.7 RPM 1410 thermally protected. Provides power through speed reducer to turn auger.

The Condenser Fan Motor on Air Cooled Mod. only - 4 X unit - Elco mod. 3RGH 70/30/1 Watts 70 - amps 0,7 - Volts 220 - Ph 1 - Hz. 50 - RPM 1300 - Thermally protected Capacitor μf 3,15 - Volts 450 - Fan 300 m/mm³/h 1750.

The Gear Reducer

This gear reducer is securely bolted on the chassis base and supports the freezing cylinder as well. On its input shaft there is fitted the drive motor. A separate output shaft with double keys is fitted in the gear box bore and connected to the auger shaft via aluminium casting coupling.

The Bin Thermostat Ranco K50.P1135 - must have its sensing capillary extended into ice room in a way that it could be contacted by the ice when storage ice room becomes filled. It terminates ice production when its capillary gets in contact with ice. It is wired in series with all other controls. It is factory set to cut-out at 1,5°C and cut-in at 4°C.

The Condenser Water Cooled is tube within a tube with end plate manifold to permit cleaning of water tube. Its heat rejection is of 12.000 Kcal/hr.

The Condenser Water Valve PENN 1/2" Bellow type - Regulated water flow through the condenser to maintain constant head pressure at 17 atm (240 psi).

The Drier Filter is Castel 4316/4 of cm³ 250 capacity with flare fitting of 1/2" - to dehydrate moisture in the system.

The Expansion Valve is FLICA mod. AMVX 3 - Press 3 bar - Office 4.5 m/m for R 404 A - meters the refrigerant R 40A 4 to the evaporator serpentine at 1.9 bar (27 psi).

The Main Contactor - with 5 N.O. contacts at 380V 25 A Kw 12,5 at 220 V 40 amp Kw 11.

The Timer (optional) - this timer has three functions: STOP, CONTINUOUS and TIME CLOCK from 0 to 24 hrs.

It will be mainly used to pre-set the system operation time in relation to the desired amount of ice. The timer box can be remotely located from the machine in a convenient and accessible position.

The Evaporator: a vertical stainless steel tube, refrigerated, and water filled. In it there is a stainless steel auger and a water seal.

The Auger: a stainless steel triple spiral auger, it pushes the ice ribbon up to the top of the evaporator.

The Water Seal: a two part "face" seal, the top half rotating with the auger, the bottom half stationary, the sealing action being where the two seal "faces" meet.

The Breaker: where the ice is compressed and much of the extra water is squeezed out of it before it reaches the ice spout.

The Thrust Bearing (Top bearing): as the ice is, pushed up the evaporator, the auger is thrust down, and pressure from the auger thrust is taken up by this bearing.

SECTION IV

ADJUSTMENT AND REMOVAL AND REPLACEMENT PROCEDURES

The procedures provided in this Section are arranged in alphabetical order, to make specific Adjustment and Removal and replacement information easy to locate.

Read the instructions thoroughly before performing any Adjustment or Removal and Replacement Procedures.

1. ADJUSTMENT OF THE BIN THERMOSTAT CONTROL

The control for the Bin Thermostat is the Temperature Control, located in the Control Box Assembly.

WARNING - The adjusting screws on the Temperature Control device have very sensitive response to adjustment. Over-adjusting or erratic guessing, can foul the instrument and cause ultimate delay and part replacement, WHICH COULD HAVE BEEN PREVENTED.

Factory settings is +1,5°C cut-out and +4°C cut-in.

2. ADJUSTMENT OF THE LEG LEVELERS

When the MF 82 Flaker is installed with the Leg Levelers, the Cabinet must be leveled in the front-to-rear and side-to-side directions. This adjustment should be performed during initial installation of the Cabinet and anytime the Cabinet is moved from the original location to another site.

A. using an open-end wrench, and a carpenter's bubble level rotate the threaded Leveler in each Leg to RAISE or LOWER the Cabinet is level in the front-to-rear direction.

B. Repeat step A, for leveling in the side-to-side direction.

C. Recheck both the front-to-rear and the side-to-side levelling and repeat adjustments, as necessary.

3. ADJUSTMENT OF THE WATER REGULATOR ASSEMBLY

The correct head pressure on MF 82 Flakers is 17 atm (240 Psi). Adjustments can be performed on the Water Regulator Assembly to increase or decrease the head pressure.

To Adjust the Water Regulator Assembly:

A. To INCREASE the Head Pressure: Rotate the adjusting Screw, on the Water Regulator Assembly IN or CLOCKWISE.

B. To DECREASE the Head Pressure: Rotate the adjusting Screw, on the Water Regulator Assembly OUT or COUNTERCLOCKWISE.

4. ADJUSTMENT OF THE WATER LEVEL INTO THE FREEZER CHAMBER

The correct Water Level in the Freezer Chamber is about 2 cm (3/4 inch) below the ice discharge opening. Low Water Level causes excessive strain inside the Freezer Assembly due to a faster freezing rate.

When the Water Level is above or below the correct level adjustment can be performed to RAISE or LOWER the Water Level by raising or lowering the Water Reservoir and its Mounting Brackets.

A. To RAISE the Water Level: loosen and remove the two screws which attach the Mounting Bracket of the Water Reservoir to the frame and raise the Water Reservoir Assembly of the desired amount; then thread the screws in the corresponding holes and tighten.

B. To LOWER the water Level: loosen and remove the two screws which attach the Mounting Bracket of the Water Reservoir to the frame and lower the Water Reservoir Assembly of the desired amount; then thread the screws in the corresponding holes and tighten.

WARNING. - Be sure the electrical power supply and the water supply are OFF, before starting any of the following REMOVAL AND REPLACEMENT procedures, as a precaution to prevent possible personal injury or damage to equipment.

5. ADJUSTMENT OF THE AUTOMATIC EXPANSION VALVE

This valve may be manually regulated by means of the adjusting stem.

Turning the adjustment to the left counter-clockwise, will increase the rate of refrigerant flow. Turning the adjustment to the right (clockwise), the refrigerant flow to the evaporator is reduced. Use hex head wrench for manual adjusting operations.

6. ADJUSTMENT OF FAN MOTOR PRESSURE CONTROL

CAUTION - To prevent electrical shock or damage to equipment, when the cover is removed ensure that power supply is switched off.

A reverse acting, automatic reset, high pressure control fitted under the control box is electrically connected to the condenser fan motor and by a capillary tube to the liquid line. Its function is to maintain the head pressure at 17 bar (240 Psi) with a fixed differential range of 1 bar (14 Psi). To adjust the condensing pressure turn the grooved adjusting stem by the special adjusting key P/n 00102300 clockwise to decrease or Counter-clockwise to increase the setting point.

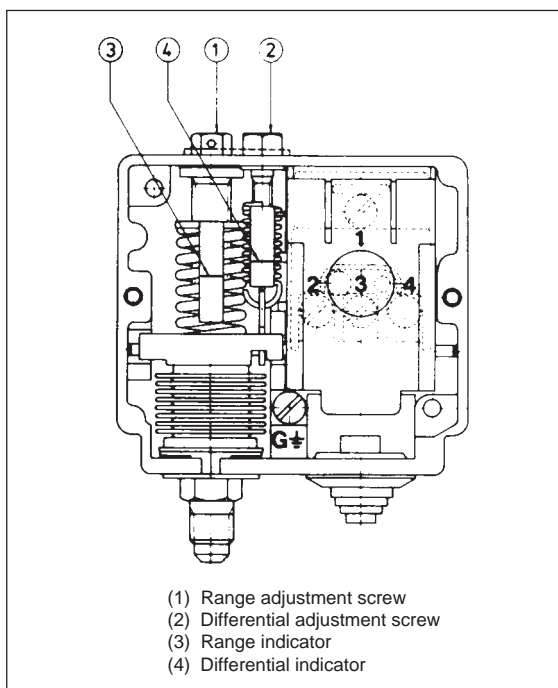

NOTE.

A. These are general steps to be followed at first, when removing any part of any refrigeration system, which are in summary.

- a) Store the refrigerant charge in compressor crankcase.
- b) Remove all refrigerant from part to be opened.
- c) Balance pressures in parts just evacuated.
- d) Isolate parts to be opened from the rest of the system.
- e) Clean and dry joints to be broken.
- f) All refrigerant openings should be immediately plugged as soon as they are opened.
- g) Upon reassembling, it is necessary to remove all the air moisture from the lines and whatever part that has been open to.

7. REMOVAL AND REPLACEMENT OF THE WATER COOLED CONDENSER

NOTE. Always install a replacement Drier, anytime the Sealed Refrigeration System is opened. Do not replace the Drier until all other repairs or replacements have been completed.

The liquid refrigerant must be removed from the condenser and the pressure in the condenser must be adjusted to atmospheric pressure. To remove the condenser:

1. Remove screws and the front panel and the left side and right side panels.
2. Bleed off or blow the refrigerant charge through the service valve after closing compressor service valves; isolate the condenser.
3. Unsolder the refrigerant inlet and outlet lines from the condenser.
4. Close off water circuit, disconnect the water inlet and outlet lines from the condenser and drain as much water as possible from the condenser.
5. Remove bolts, lockwashers and washers which secure the condenser to the chassis mounting base.
6. Remove the condenser from the cabinet.

NOTE. Thoroughly evacuate the System to remove moisture and non - condensables.

B. To replace the Condenser, reverse the removal procedure.

8. REMOVAL AND REPLACEMENT OF THE COMPRESSOR ASSEMBLY

NOTE. Always install a replacement Drier, anytime the sealed Refrigeration System is opened. Do not replace the Drier until all other repairs or replacements have been completed.

- A. To remove the Compressor Assembly:
- 1) Remote screw and Right, Front, Rear and Left Panels.
 - 2) Remove two screw and the Cover from the Compressor Junction Box.
 - 3) Disconnect the electrical leads at the Compressor Junction Box that originate in the Control Box.
 - 4) Close both suction and discharge Service Valves. Bleed off or blow the refrigerant in compressor through the Service Valves.

WARNING - Removal of compressor because of its weight could present a problem. Carts, small Hydraulic Hoists, etc. must be made available to move the compressor.

5) Unbolt the suction service and discharge service valves from the compressor (DO NOT REMOVE THE LINES FROM THE VALVES).

6) Immediately plug all the openings through which refrigerant flows using dry rubber, cork stoppers or tape.

7) Disconnect the compressor base bolts that hold the compressor to the base.

8) Plug compressor refrigerant opening to prevent oil from spilling out during compressor removal, if this one is tilted.

9) Slide the compressor out from unit chassis from the rear side.

B) To replace the compressor assy reverse the removal procedures.

9. REMOVAL AND REPLACEMENT OF THE DRIER

A. To remove the Drier:

1) Remove screws and all service panels.

2) Remove screws and Drier brace attaching the drier to the Chassis.

3) Bleed off or blow the refrigerant charge through the service valve.

4) Unloose the refrigeration lines flare nuts at each end of Drier, remove the Drier and separate drier from the drier brace.

A. To replace the Drier:

CAUTION

1. If the factory seal is broken on the replacement drier, exposition of it to the atmosphere, more than a few minutes, the Drier will absorb moisture from the atmosphere and loose substantial ability for moisture removal.

2. Be sure the replacement Drier is installed with the arrow positioned in the direction of the refrigerant flow.

1) Remove the factory seals from the replacement drier and install the drier in the refrigerant lines with the arrow positioned in the direction of the refrigerant flow.

2) Install the drier brace on the drier.

3) Tighten the flare nuts to both drier fittings to connect the refrigerant lines.

4) Purge the system and check for leaks.

5) Thoroughly evacuate the system to remove moisture and non-condensables.

6) Charge the system with refrigerant, by weight. SEE NAMEPLATE.

7) Re-mount all Service Panels.

10. REMOVAL OF EXPANSION VALVE

A. To remove the expansion valve:

1. Remove screws and service panels.

2. Close service valves on liquid line.

3. Run the compressor for a moment until the evaporator coil has no liquid refrigerant in it.

4. With the compressor idling, equilibrate the pressure by cracking the liquid line service valve.

5. Turn the suction service valve stem all the way in.

6. Dry and clean the expansion valve accurately.

7. Remove the liquid line and unbolt the valve.

8. Seal refrigerant openings immediately.

B. To replace the expansion valve reverse the removal procedures.

11. REMOVAL AND REPLACEMENT OF THE WATER REGULATOR ASSEMBLY - WATER - COOLED MODELS

A. To remove the Water Regulator Assembly:

1. Remove screws and the Service Panels.

2. Bleed off or blow the refrigerant charge through the Schrader valve.

3. Unsolder the Capillary line from the Water Regulator Assembly, where connected at the process header.

4. Disconnect the water inlet line at the rear of the Water Regulator.

5. Disconnect the Condenser water inlet tube at the front of the Water Regulator.

6. Remove two screws, lockwashers and washers which attach the Water Regulator Assembly bracket to the Chassis base and remove the Water Regulator Assembly and bracket.

NOTE. - Thoroughly evacuate the System to remove moisture and non - condensables.

B. To replace the Water Regulator Assembly reverse the removal procedure.

12. REMOVAL AND REPLACEMENT OF THE AUGER, WATER SEAL, BEARINGS AND COUPLING

A. To Remove the Auger, Water Seal, Bearings, and Coupling:

1. Remove screws and the Front Panel and the Top Panel. Shut close water supply. Drain the water reservoir and freezer assy using the drain tube attached to the freezer water inlet.

2. Remove the two screws that secure the spout to the stop of the Freezer Assembly.
3. Disconnect wires from micro box spout switch.
4. Remove micro-box and the spout assy.
5. Remove center plastic cap that protects top bearing.
6. Unloose and remove center bolt that secures the ice breaker to the auger.
7. Unloose and remove 8 screws that hold the ice breaker to freezer barrel.
(Two longer screws are used with freezer side bracket).
8. Insert two of these screws into two threaded-blind holes, which must have no bottom on barrel and by evenly drawing them down, ice breaker is lifted up.
9. Grasp the ice breaker and lift it up entirely. Worm shaft will remain into the freezer worm tube.
10. With a rowhide mallet or a piece of wood placed on the bottom end of the top bearing, tap the bottom of the bearing to break it loose to be pulled out from ice breaker.
11. Clean away old grease and replace the "O" rings in the ice breaker.
12. Insert in auger hub threaded hole an eyebolt of 16 m/m in order to offer sufficient and positive hook for pulling-out the auger.
13. Lift and pull-out the auger with the help, eventually of a small hydraulic Hoist.

NOTE:

1. Any time the Auger is removed for replacement, or, for the inspection and replacement of the Bearing or Coupling, use extra care in handling the Water Seal parts, so no dirt or foreign matter are deposited on the surfaces of the Seal.

2. If there is any doubt about the effectiveness of the Water Seal or O-Ring, REPLACE THEM. A dirty, worn or faulty Water Seal or O-Ring will cause a leak and ultimately require a second, time consuming, removal and replacement procedure to be performed, that COULD HAVE BEEN PREVENTED.

3. Lower bearing or water seal should be removed by pulling-out the bearing retainer from the bottom of freezer barrel. You can heat the bearing retainer with a soft flame. The bearing will drop out by itself.

14. Remove screws and lockwashers which attach the Freezer Assembly to the Adaptor on the Gear box.

15. Raise the Freezer Assembly off of the Adaptor, to gain access to the Bearing Retainer; then, temporarily secure the Freezer Assembly out of the way to allow room to work.

16. Unloose and remove the four screws that secure the bottom flange to the worm tube.

17. Push out to remove the seal ring.

18. Remove the clip ring and the bearing from the bearing retainer.

19. Inspect the lower half of the Water Seal. If reusable, use care to protect it from dirt, etc. prior to replacement procedure.

20. Inspect the lower Bearing and, if the Bearing is dry replace it with a new one.

21. Inspect the O ring of lower bearing retainer - eventually replace it with a new one.

22. Reach through the Adaptor and remove the Coupling for inspection.

23. Check the Coupling for cracks, chipping and excessive wear.

- B. To replace, the Auger, Water Seal, Bearings, and Coupling, reverse the removal procedure.

NOTE:

1. When installing the Bearing, in the bearing retainer carefully tap a piece of wood positioned across the bearing, to evenly seat the Bearing in the retainer.

2. After assembling the ice breaker on the upper end of the Auger and BEFORE installing the Cap apply an ample coating of vary bond grease type Never Seez food grade H1 - certified -20° C +150° C Grease, P/ N263612 00, to the upper part of the Bearing, the Cap Screw and Washer. Then, install the Cap in place.

13. REMOVAL AND REPLACEMENT OF THE FREEZER ASSEMBLY

NOTE:

1. The Cabinet may have to be removed from its permanent location, especially if located in a corner, in order to have access to the left side and rear of the Chassis.

2. In addition to shutting OFF electrical power and inlet water to the icemaker, be sure to disconnect the inlet water line BEFORE moving the icemaker from the permanent location.

3. Always install a replacement Drier, anytime the sealed refrigeration system is opened. Do not replace the Drier until all other repair or replacement has been completed.

A. To Remove the Freezer Assembly:

1. Remove screws and left and right side rear panels.
2. Refer to procedure IV-12 and remove the Spout Assembly, Ice Breaker and Auger.
3. Remove Corbin clamp and Tygon tube from the Freezer Assembly that connects to the Water Reservoir Assembly.
4. Perform operation at steps 2-3-4-5 at procedure IV-10.
5. Disconnect suction line joint from the freezer.
6. Unsolder the refrigerant inlet line at the freezer.
7. Remove screws that secure bracket of freezer to the left side of chassis.
8. Remove screws, lock washers and washers which attach the bottom of the Freezer Assembly to the Adaptor on the Gear box.
9. Lift the Freezer Assembly up and off of the Adaptor of Gear box.

NOTE: Thoroughly evacuate the System to remove moisture and non - condensables.

B. To replace the Freezer Assembly, reverse the removal procedure.

14. REMOVAL AND REPLACEMENT OF THE WATER RESERVOIR ASSEMBLY

A. To remove the Water Reservoir Assembly:

1. Remove screws and the left Panel and the Top Panel. Close the Water Supply. Drain water reservoir and freezer assy. Using the drain tube attached to the freezer water inlet.

NOTE: Be prepared with container or rags, to catch water left in lines, when lines are disconnected in next steps, to prevent draining water on parts, components, electrical lines, etc.

2. Disconnect the water inlet tube from the Water Reservoir Assembly.

3. Remove two corbin clamps and two tubes from the bottom of the water reservoir assy and damp all water in them by bending them down in a pail.

4. Unscrew and remove the screws that secure the water reservoir bracket.

5. Remove the Water Reservoir Assembly, from the mounting bracket.

B. To replace the Water Reservoir Assembly, reverse the removal procedure.

NOTE: Check that the installed replacement Water Reservoir Assembly float moves freely.

15. REMOVAL AND REPLACEMENT OF THE DRIVE MOTOR

A. To remove the drive motor assembly:

1. Remove screws and front, and left side panels.
2. Disconnect wire leads to motor.
3. Remove four hex head bolts, lockwashers and washer which attach the motor to the gear reducer.
4. Remove the drive motor out of the gear reducer.

B. To replace the drive Motor reverse the removal procedure.

16. REMOVAL AND REPLACEMENT OF GEAR BOX

A. Remove screws and all service panels.

1. Follow the procedure at step 15 to remove the drive motor.

2. Remove four nuts and washers which hold the gear box adaptor to the evaporator assembly.

3. Unloose and remove screws securing upper evaporator bracket to left side chassis.

4. With a small hydraulic Hoist raise the evaporator assembly to facilitate removal of entire gear box.

5. Unloose and remove four nuts holding the gear box to unit base. The gear box is now loose and can be removed. Do not tilt to avoid oil spillage.

B. To remount Gear Box assembly reverse the removal procedure taking care to position correctly the output shaft with its keys well in shape.

SECTION V

SERVICE DIAGNOSIS

The Service Diagnosis Sections is for use in aiding the servicemen in diagnosing a particular problem for pin-point the area in which the problems lies, thus an ever available reference for proper corrective action.

The following chart lists corrective actions for the causes of known symptoms of certain problems that can occur in the ice makingrefrigeration system.

1. ICE MAKING - REFRIGERATION SYSTEM

SYMPTON	POSSIBLE CAUSE	SUGGESTED CORRECTION
2nd Warning Light glows-intermittently Lo-refrigerant press.	Incorrect refrigerant suction pressure Moisture in system. Overcharge of oil in system. Not enough refrigerant. No water in float reservoir.	Add Refrigerant to raise suction pressure. Raise head press. control setting. Purge - change drier. Dehidratate & recharge the system. Check for refrigerant leak and re-charge correctly. Check for water inlet through float ball or for water waste.
3rd Warning Light glows-intermittently Lo-water pressure.	Intermittent water supply or too low water pressure.	Water shut-off valve closed. Check and clean water strainer
The unit does not make ice.	Drive coupling worn or splitted. Gear in gear box stripped. Water not entering freezer assy.	Unloose and pull-ont gear box and change coupling. Check and replace. Check water line from reservoir to freezer.
1st Red Light glows Hi-pressure excessive.	Hi-pressure control cut-off unit operation. Blown fuse.	Check cooling water at condenser. Condenser tube clogged-up. Water regulating valve to be re-adjusted. Fan motor out of operations. Dirty condenser. Replace fuse and check for cause of blow fuse.
Green Light is off. Unit will not run	Loose electrical connection Switch in OFF position. Inoperative master switch. Spout switch cut-out	Check wiring. Turn switch to ON. Replace switch Check ice chute arrangement.

SYMPTON	POSSIBLE CAUSE	SUGGESTED CORRECTION
Unit run intermittently (Start and stop) 5th Warning light glows.	Auger rubbing in freezer barrell - Freezer barrell scored. Auger bearing seized. Gear box seized - No lubricant. Freeze up. Drive motor running on reverse.	Remove auger to check situation smooth freezer barrel and auger spiral with sand paper or replace them. Replace bearing. Add lubricant or replace gear box. Melt ice in freezer and remove ice breaker and auger to check cause of freezer-up. Interchange connection wires.
Excessive noise.	Gear reducer loose on frame. Drive motor end-play or worn bearings. Motor compressor not floating on rubber cushions. Water level in evaporator too low.	Tighten. Repair or replace. Loosen hold-down bolts. Set water level correctly
Water leaks.	Damaged water seal. Gravity feed line leaking. Water level in reservoir too high.	Replace seal. Check hose clamp. Adjust water level.
Compressor cycles intermittently. 6th Warning light glows.	Low voltage. Dirty Condenser. Water regulating valve too close. AEV valve closed. Non-condensable gases in system.	Check for overloading. Clean condenser. Open water valve. Adjust. Purge-off.
Making wet ice.	Surrounding air temperature above 40°C (100°F). Under-or over-charge of refrigerant. Closed AEV. Faulty compressor valve plate. Float ball full of water.	Correct or move unit to cooled location. Re-charge with proper amount. Adjust valve for correct refrigerant flow. Repair or replace. Replace.
Low ice production.	Loss of refrigerant, under or overcharge of refrigerant. Plugged condenser water tubes. Low water level in the reservoir. Overcharge of oil in system.	Check and recharge with proper amount of refrigerant. Clean condenser. Check float valve operation. Check at oil sight glass. Lower to 1/2 sight glass.
Gear box noise.	Low on lubricant.	Remove filling plug and add synthetic Oil.

SECTION VI

WIRING DIAGRAMS

This section is provided as an aid in understanding the electrical circuit of the MF 82 Flaker.

The Wiring Diagrams in this Sections are:

Figure 6.1 - Wiring diagram - MF 82 - WS and AS-14 (400/50/3+N).

Figure 6.2 - Functional Electric Diagram for MF 82 WS-AS-14.

WARNING - When conducting a continuity check of the MF 82 Flaker:

- 1. Disconnect the main power source.**
- 2. DO NOT use an incandescent lamp or jumper wire, conduct all tests with a voltohm-meter.**

WIRING DIAGRAM MF 82

400 / 50 / 3 + N

F.G. 6.1

THIS UNIT IS SHOWN IN NORMAL ICE MAKING MODE

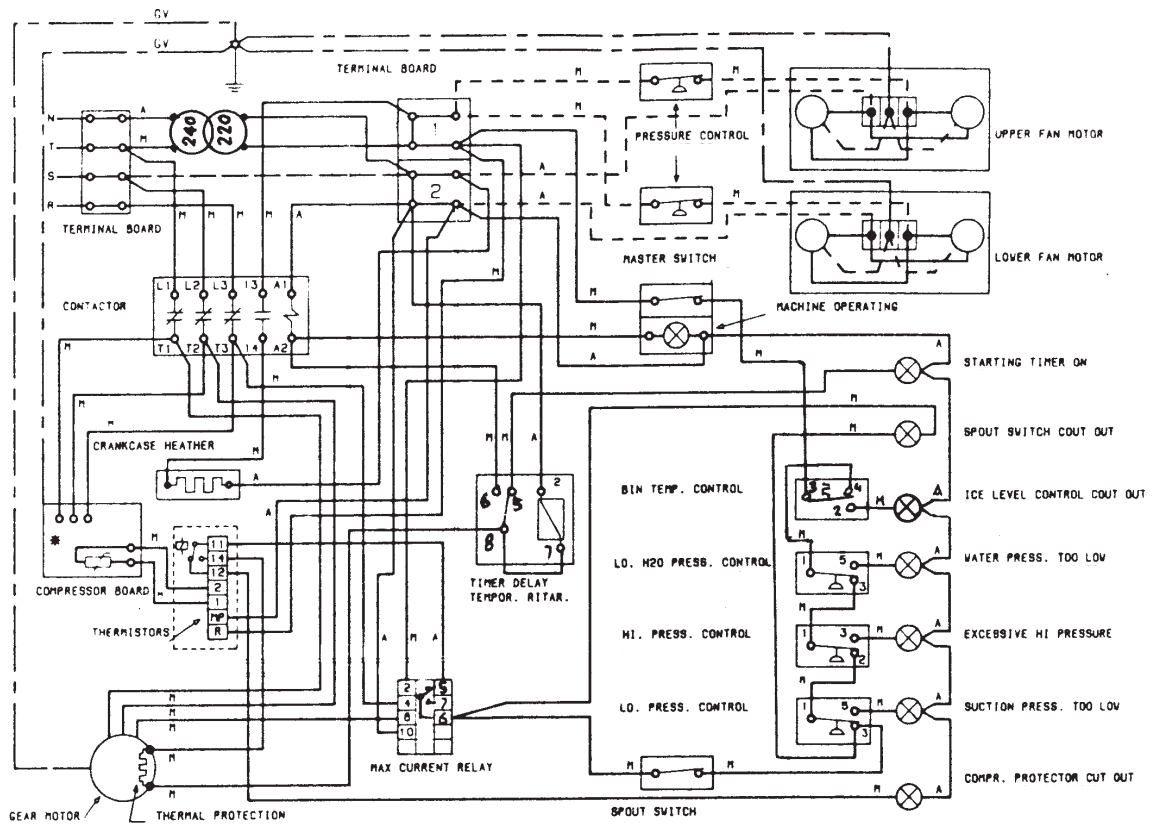

* FOR COMPRESSOR ELECTRIC CONNECTIONS REFER TO COMPRESSOR WIRING DIAGRAM IN COMPRESSOR TERMINAL BOX

--- JUST FOR AIR COOLED UNIT

— CONNECTION REPLACES NEUTRAL FOR MODEL 220/50-60/3

MF 82 FUNCTIONAL ELECTRIC DIAGRAM

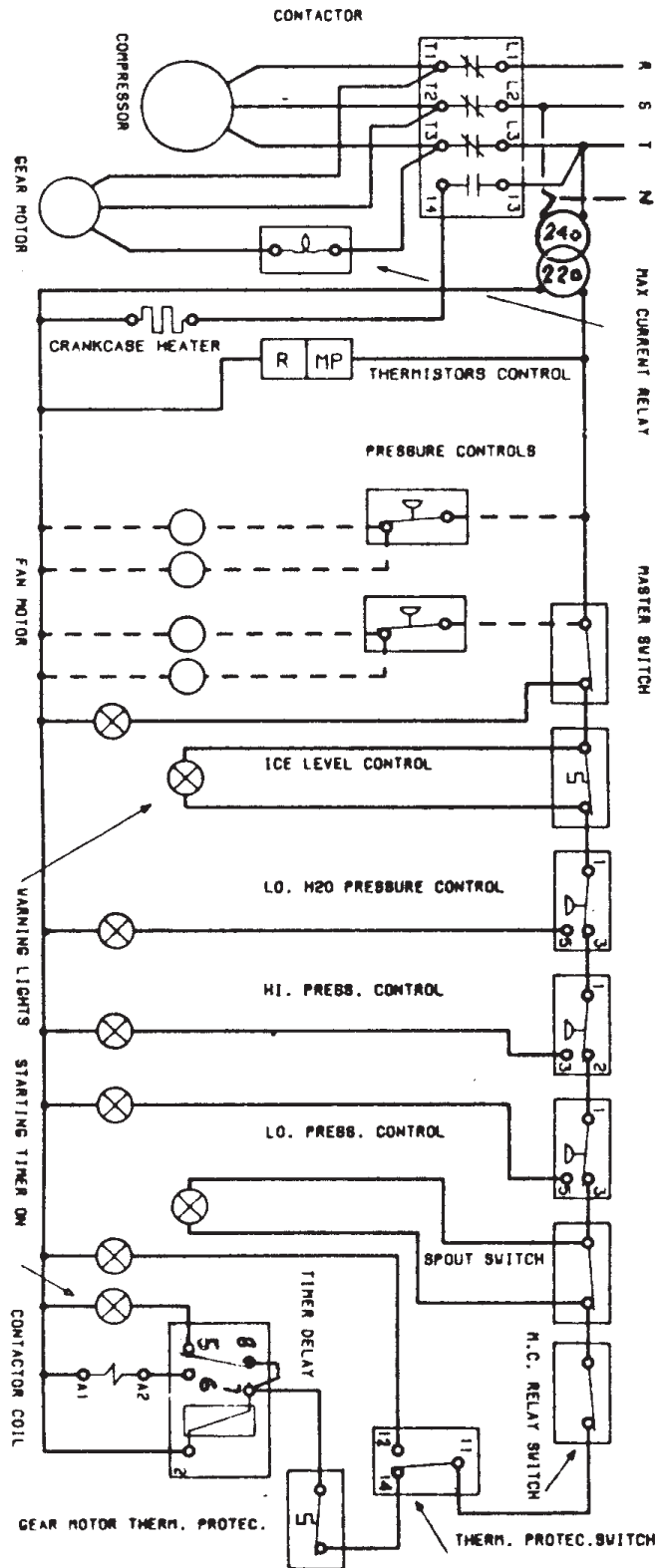

SECTION VII

MAINTENANCE & CLEANING INSTRUCTIONS

GENERAL

The periods and procedures for maintenance and cleaning are given as guides and are not to be construed as absolute or invariable. Cleaning especially will vary, depending upon local water conditions and the ice volume produced and, each icemaker must be maintained individually, in accordance with its own particular location requirements.

ICEMAKER

THE FOLLOWING MAINTENANCE SHOULD BE SCHEDULED AT LEAST TWO TIMES PER YEAR ON THIS ICEMAKER. CALL YOUR AUTHORIZED SCOTSMAN SERVICE AGENCY.

1. Check and clean optional water line strainers or water purification system.

2. Remove screws and top and front panel.

3. Remove cover from water reservoir and depress the float to ensure that a full stream of water enters each reservoir.

4. Check that the icemaker cabinet is level, in side-to-side and front-to-rear directions.

5. Check that the water level in water reservoir is below the overflow and is level to correspond 20 mm below the ice discharge opening.

6. Clean water reservoir and interior of the freezer assembly, using a solution of SCOTSMAN Ice Machine Cleaner. Refer to CLEANING-Icemaker.

NOTE. *Cleaning requirements vary according to local water conditions and individual user operation. Visual inspection of the auger before and after cleaning will indicate frequency and procedure to be followed in local areas.*

7. When doubtful about refrigerant charge, install refrigerant gauges on Service valves and check gauge for compressor head and check gauge for compressor head pressure. See Nameplate for refrigerant charge specifications.

8. Check gauge for suction line pressure: will be 1.9 Bar (27 Psig).

9. Check drive motor operation: Normal operating temperatures about 70° which is hot to touch. Check with Ammeter amps drawn and make sure they are in the limits of Drive motor windings.

10. Check setting and function of all the pressure controls also make sure that their corresponding light will glow.

NOTE. *Time delay - timer - must be maintained set on 5 minutes. This cause a delay of 5' at every start up.*

WARNING - Disconnect electrical power supply before removal procedure.

NOTE. *Before the next step, move Master ON-OFF switch OFF, to stop the fan motors and ice-makers.*

11. Inspect the top bearing in the ice breaker, wipe clean of old grease and apply a coating of food grade grease, SCOTSMAN P/N 263612.00 or equivalent.

12. Clean the air-cooled condensers, using a vacuum cleaner, a soft broom or brush. The icemaking performance and capacity is affected by the clean condition of the air-cooled condenser. Instruct customer to clean frequently and to be sure icemaker and fan motor are OFF.

13. Check that fan blades move freely, are not touching any surfaces and are not bent or out of balance.

14. Check for refrigerant leaks.

15. Check for water leaks. Pour water down drain line to be sure that drain line is open and clear.

16. Check the quality of ice. Ice should be slightly wet when formed, but will cure rapidly to normal hardness in the bin.

17. Check the bin thermostat control bulb, hold ice on the control bulb of each system to test icemaker shut-off.

NOTE. *The bin thermostat is factory set at 4°C differential and should keep the entire icemaker system shut off at least 10 minutes in high ambient temperatures, longer in low ambient temperatures during normal operation. Settings are 1,5°C CUT-OUT and 4°C CUT-IN.*

18. Make sure that water lines in water cooled condenser are free from any excess of water minerals, otherwise arrange to clean the tube with a power driven wire brush or running through it a weak acid solution made with 20 percent of Hydrochloric acid.

19. Check compressor oil level through sight glass. Stop unit operation and after 10" see that oil level is 2/3 m/m above center line of sight glass.

20. Check gear box oil level through its sight glass every 6 months. Oil must be replaced every 3 years. Use mineral oil ESSO SPARTAN EP 320 or a similar one with a viscosity of 32° cst at 40°C.

CLEANING

1. Remove screws and the top, left and front panel.

2. Move master ON-OFF toggle switch to OFF position.

3. Remove reservoir cover and block the float in water reservoir.

4. Drain the water reservoir and freezer assembly using the drain tube attached to the freezer water inlet. Return the drain tube to its normal upright position and replace the end cap.

WARNING - SCOTSMAN Ice Machine Cleaner contains Phosphoric and Hydroxyacetic acids. These compounds are corrosive and may cause burns. If swallowed, DO NOT induce vomiting. Give large amounts of water or milk. Call Physician immediately. In case of external contact flush with water. KEEP OUT OF THE REACH OF CHILDREN.

5. Prepare cleaning solution: Mix two liters of SCOTSMAN Ice Machine Cleaner with 10 liters warm water.

6. Slowly pour the cleaning solution into water reservoir until it is full. Wait 15 minutes.

7. Move master ON-OFF switch to ON position and after 5 minutes of delay as the ice maker begins to use water from the reservoir continue to add more cleaning solution to maintain full reservoir, if any has remained.

8. Continue icemaking, clearing ice from the spout, until the water reservoir is empty. DO NOT allow the icemaker to operate with empty reservoir.

9. Move master ON-OFF switch to OFF.

10. Flush-out the remaining cleaning solution from freezer, as per step 4 Wash and rinse the water reservoir.

11. Remove the block from the float in the water reservoir and allow new fresh water to fill up the freezer. Move the master ON-OFF switch to ON position.

12. Continue icemaking for at least 15 minutes, to eliminate any remanent of the cleaning solution. Check ice for acid taste - continue icemaking until ice tastes sweet.

CAUTION - DO NOT use ice produced from the cleaning solution. Be sure none remains in the bin.