

VIADRUS

VIADRUS HERCULES DUO MANUAL FOR BOILER OPERATION AND INSTALLATION



Table of contents:

page.

1. Use of boiler and its advantages	3
2. Boiler technical data	3
3. Description	5
3.1 Boiler construction	5
4. Positioning and installation	9
4.1 Regulations and directives	9
4.2 Positioning options	11
4.3 Hydraulic connection diagram	13
5. Boiler installation	15
5.1 Delivery and accessories	15
5.2 Installation procedure	17
5.2.1 Boiler conversion when switching over from automatic to manual operation	21
5.2.2 Boiler conversion when switching over from manual to automatic operation	21
5.2.3 Boiler conversion from right-hand design to the left-hand design	22
5.2.4 Wiring diagram	25
6. Automatic operation	31
6.1 Control, regulation and security elements	31
6.1.1 Saphir regulator	31
6.1.2 Safety thermostat	35
6.1.3 Temperature sensor on the fuel feeder	35
6.1.4 Emergency fire-extinguishing system	35
6.1.5 Forced withdrawal of superfluous heat	35
6.1.5.1 Forced withdrawal of superfluous boiler heat	35
6.1.5.2 Forced withdrawal of superfluous water heater heat	35
6.2 SAPHIR regulator parameters	35
6.2.1 Description of SAPHIR regulator parameters	41
6.3 QAA 88 device	52
6.3.1 Parameters setting and displaying	53
6.3.1.1 Fuel feeder and ventilator performance curve – lignite	54
6.3.1.2 Fuel feeder and ventilator performance curve – hard coal	55
6.3.1.3 Fuel feeder and ventilator performance curve – wood pellets	55
6.3.2 Faults	56
6.4 Service board	57
6.5 Control activity before start	57
6.6 Setting of parameters before the equipment start-up	59
6.7 Boiler putting into operation	59
6.8 Important warnings	60
6.9 Maintenance	61
6.10 HMI (ACX84.910/ALG) service unit for Saphir regulator operation	61
7. Manual operation	61
7.1 Control, regulation and security elements	61
7.1.1 Equipment for superfluous heat withdrawal	61
7.2 Control activity before start	65
7.3 Setting and description of Saphir regulator – Manual operation	66
7.3.1 Pump heating circuit	66
7.3.2 Mixing heating circuit	66
7.4 Boiler putting into operation	66
7.5 Boiler attendance by user	67
7.6 Important warnings	68
7.7 Maintenance	68
8. Instructions for product disposal after expiration of its lifetime	69
9. Guarantee and liability for defects	69

Dear customer,

Thank you for the purchase of automatic solid fuel boiler **VIADRUS HERCULES DUO** whereby you expressed your trust to ŽDB GROUP a.s., member of KKCG Industry, VIADRUS plant.

Please read this manual (particularly chapter no. 6 – Automatic operation and chapter no. 7 – Manual operation) that provides you with instructions for the proper use of your new product that you have to get familiarized with at the very beginning. Please follow the current information and take notice of instructions issued by the manufacturer or installation company that installed your boiler so that the long-life trouble-free operation of your boiler can be guaranteed both to your and our satisfaction.

1. Use of boiler and its advantages

Hot-water automatic solid fuel boiler **VIADRUS HERCULES DUO** is destined particularly for heating the family houses, cottages, office buildings, small premises etc.

Boiler advantages

- automatic boiler operation, equithermal control
- possibility of HW heating
- possibility of biomass – wood pellets combustion
- mechanical fuel feed from inbuilt reservoir
- simple, time non-consuming boiler attendance and maintenance
- low operating costs

2. Boiler technical data

Tab. no. 1 Boiler dimensions, technical parameters

		VIADRUS HERCULES DUO Automatic operation	VIADRUS HERCULES DUO Manual operation
Weight			
- small reservoir valve Regulus	kg	416	416
- large reservoir valve Regulus	kg	446	446
- small reservoir aftercool. loop	kg	435	435
- large reservoir aftercool. loop	kg	466	466
Water space volume	dm ³	33,3	33,3
Smoke neck diameter	mm	156	156
Boiler heat-delivery surface	m ²	2,7	2,7
Small fuel reservoir capacity	dm ³	269	269
Large fuel reservoir capacity	dm ³	528	528
Boiler with small fuel reservoir dimensions width x depth x height	mm	1335 x 754 x 1676	1335 x 754 x 1676
Boiler with large fuel reservoir dimensions: width x depth x height	mm	1985 x 754 x 1676	1985 x 754 x 1676
Filling hole dimensions – small reservoir	mm	422 x 545	300 x 320
Filling hole dimensions – large reservoir	mm	422 x 1210	300 x 320
Boiler degree acc. to EN 303 - 5	-	2	1
Maximum operating water overpressure	bar	2,5	2,5
Testing operating water overpressure	bar	5	5
Recomm. heating water operating temperature	°C	50 - 80	60 - 85
Minimum return water temperature	°C	45	45
Boiler hydraulic loss	Pa	75	75
Noise level	dB	Does not exceed level 65 dB (A)	Does not exceed level 65 dB (A)
Chimney draught	Pa	10 – 15	15
Boiler connections - heating water	Js	G 2"	G 2"
- return water	Js	G 2"	G 2"
Connecting voltage		1/N/PE AC 230 V ~ 50 Hz TN - S	
Electric input (ventilator + motor)	W	230	
IP code		IP 44	

Tab. no. 2 Thermal technical parameters of VIADRUS HERCULES DUO boiler– Automatic operation

		HARD COAL	LIGNITE	PELLETS
Nominal output	kW	21	21	21
Minimum output	kW	6,3	6,3	6,3
Fuel consumption at nominal output	kg.h ⁻¹	3,8	5,25	5,72
Fuel consumption at minimum output	kg.h ⁻¹	0,69	1,58	1,72
Fuel value	MJ.kg ⁻¹	25,16	19,17	16,78
Fuel consumption in upkeep regime	kg.h ⁻¹	0,13	0,10	0,35
Burning time at nominal output – small reservoir	h	40 h 30 min	36 h 25 min	23 h 10 min
Burning time at nominal output – large reservoir	h	79 h 30 min	71 h 30 min	45 h 20 min
Efficiency	%	up to 79,1	up to 75,1	up to 78,8
Flue gas temperature	°C	160 - 275	180 - 295	150 - 275
Flue gas mass flow at outlet - at nominal output	kg.s ⁻¹	0,015	0,021	0,016

! Important warning:

The stated values vary in dependance on the sort, quality and moisture of used fuel. Therefore some corrections might be necessary when setting the stoking cycle (time for fuel feed versus time for fuel afterburning). For example if unburned fuel slivers appear on the grate and in the ash-pan it stands to reason that stoking is faster than burning and the stoking cycle must be reduced – see parameters description

Tab. no. 3 Thermal technical parameters of VIADRUS HERCULES DUO boiler – Manual operation

		COKE	HARD COAL	WOOD
Nominal output	kW	22,5	16,5	15,75
Minimum output	kW	11,3	8,25	4,73
Fuel consumption at nominal output	kg.h ⁻¹	3,64	2,8	5,04
Fuel value	MJ.kg ⁻¹	27,8	28,31	15,01
Burning time at nominal output	h	4	4	2
Efficiency	%	80	75	75
Flue gas temperature	°C	220 – 250	220 - 300	220 – 300
Flue gas mass flow at outlet				
- at nominal output	kg.s ⁻¹	0,010	0,013	0,009
- at the minimum output	kg.s ⁻¹	0,005	0,006	0,003

Parameters of prescribed fuel – fuel used for tests in SZÚ:

- water content max. 12 % (hard coal, wood pellets),
max. 20 % (lignite)
12 – 20 % (wood)
- volatile combustible content 28 – 40 %
- ash deformation by melting temperature > 1150 °C
- low sintering capacity
- small moisture expansion

Tab. no. 4 Specified fuel

Fuel	Sort of fuel	Operation	Granularity [mm]	Fuel value [MJ.kg ⁻¹]
Coke		Manual	24 – 60	27 – 30
Hard coal		Manual	24 – 60	21 – 28,5
	Peas	Automatic	10 – 18	21 – 28,5
Lignite	Nub 2	Automatic	10 – 25	16,5 – 19,5
	Nub 3		10 – 16	16,5 – 19,5
Wood		Manual	blocks diameter Ø 40 up to 100 mm blocks length 300 mm	15 – 17
Biomass	Wood pellets	Automatic	Ø 6 - 8	15 – 19

Tab. no. 5 Specified fuel – lignite (Automatic operation)

Fuel	Granularity [mm]	Fuel value [MJ.kg ⁻¹]	Ash content [%]	water content [%]	sulphur content [%]	Specific sulphur content [g/MJ]	Tar content in dry matter [%]	Tar content in combustible matter [%]
Screened lignite from Bílina mine (coal cleaning plant) – nub 2	10 - 25	17,6	9,8 (in anhydrous condition)	max. 20	0,77	0,44	15,1	15,71

Pellets must conform at least to one of following directives or standards:

- Directive no. 14-2000 MŽP ČR
- DIN 517 31
- ÖNORM M 7135

Specified granularity of pellets 6 to 8 mm
Water content in fuel max. 12 %
Ash content max. 1,5 %

ATTENTION! A low fuel quality can distinctly negatively influence the boiler output and emission parameters.

3. Description

3.1 Boiler construction

The pressure components of boiler correspond to strength requirements according to:
EN 303-5 Boilers for central heating– Part 5: Solid fuel boilers for central heating with manual or automatic feed and nominal heat output maximum 300 kW – Terminology, requirements, testing and marking.

The cast iron body positioned on the basement welded of steel sheets is the core part of the boiler. The boiler drum consists of 4 sections connected by means of pressed-on boiler inserts of 56 mm diameter and secured by anchor bolts. The sections form the combustion space, ash-pan space (for manual regime), water space and convective part. The heating water inlet and outlet are situated at the rear of the boiler.

The rear boiler section has the smoke adapter and heating water flange in the upper part and the return water flange is in the lower part of the basement. The stoking door and ash-pan door are fastened to the front section. The folding grate is positioned behind the ash-pan door (Manual operation).

Under the cast iron body there is positioned the burner with mixer (see. Fig. no. 4 and Fig. no. 5) that consists of cast iron grate and retort. The fuel is fed from the reservoir through the feed screw emptying into retort on the cast iron grate. The retort for fuel feed is equipped with holes for combustion air pressure balancing in the burner which prevents the flame bursting into the feeder during burning process (hard coal and lignite).

The ash-pan drawer is under the combustion chamber. Next to the boiler there is positioned the fuel reservoir that empties into fuel feed screw.

Ventilator for combustion air is positioned behind the fuel reservoir and is connected to the burner. Ventilator has the modulation control by SAPHIR regulator depending on the required output.

Heating water inlet and outlet are situated at the rear of the boiler by means of two flanges 2" for connection to the heating system. The temafast Ø 60 x 48 x 2 mm sealing is between the boiler and flange.

All components (boiler drum, basement) are insulated by means of health non-detrimental mineral insulation that reduces the heat transmission losses.

The high-quality komaxit spray is used for boiler shell colour treatment.

The boiler is made in left & right design.

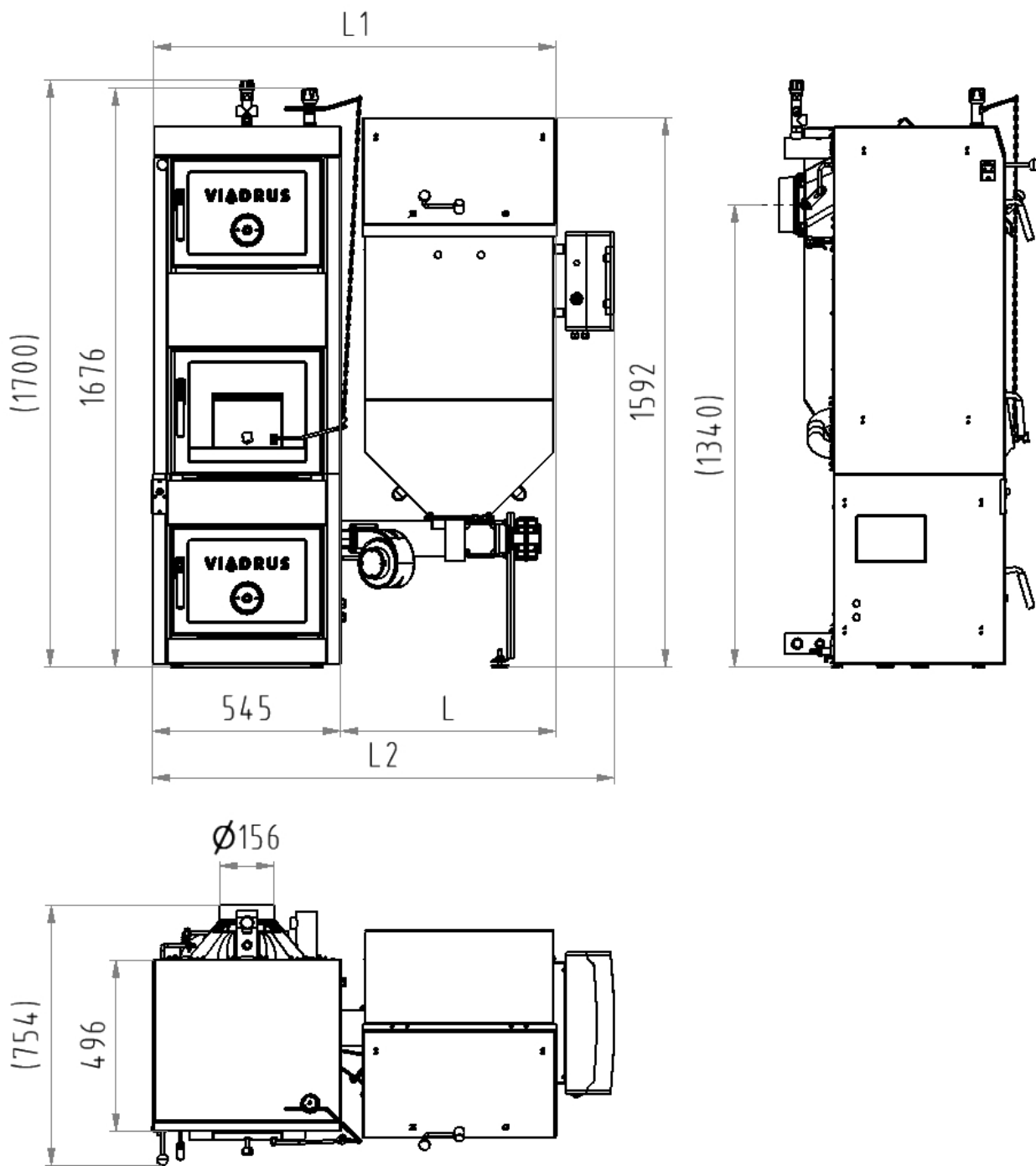

Length	Small reservoir	Large reservoir
L [mm]	623	1272
L1 [mm]	1168	1817
L2 [mm]	1335	1985

Fig. no. 1 Main dimensions of VIADRUS HERCULES DUO boiler with two-way safety valve DBV 1 – 02 (right-hand version)

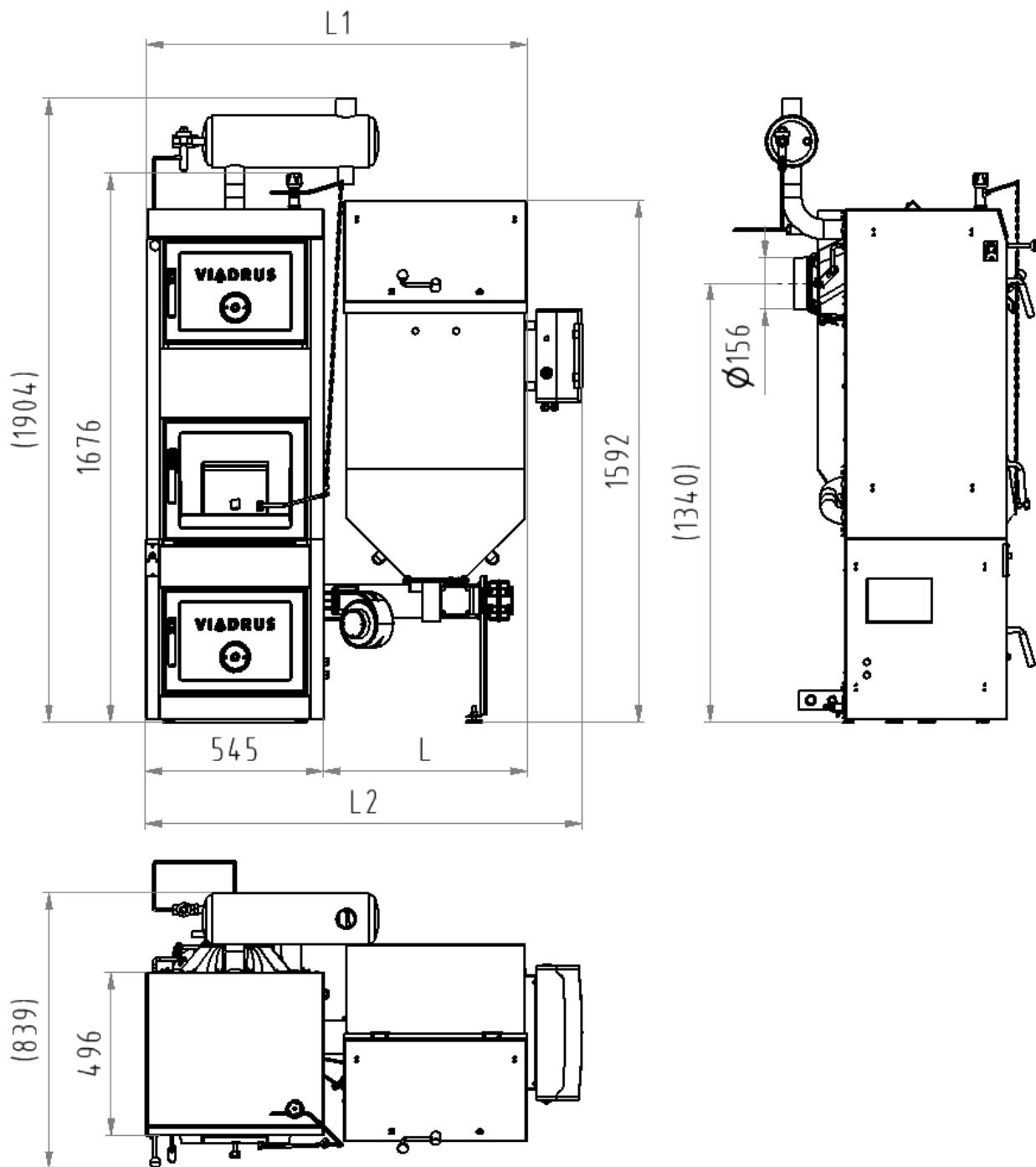

Length	Small reservoir	Large reservoir
L [mm]	623	1272
L1 [mm]	1168	1817
L2 [mm]	1335	1985

Fig. no. 2 Main dimensions of VIADRUS HERCULES DUO boiler with after- cooling loop (right-hand version)

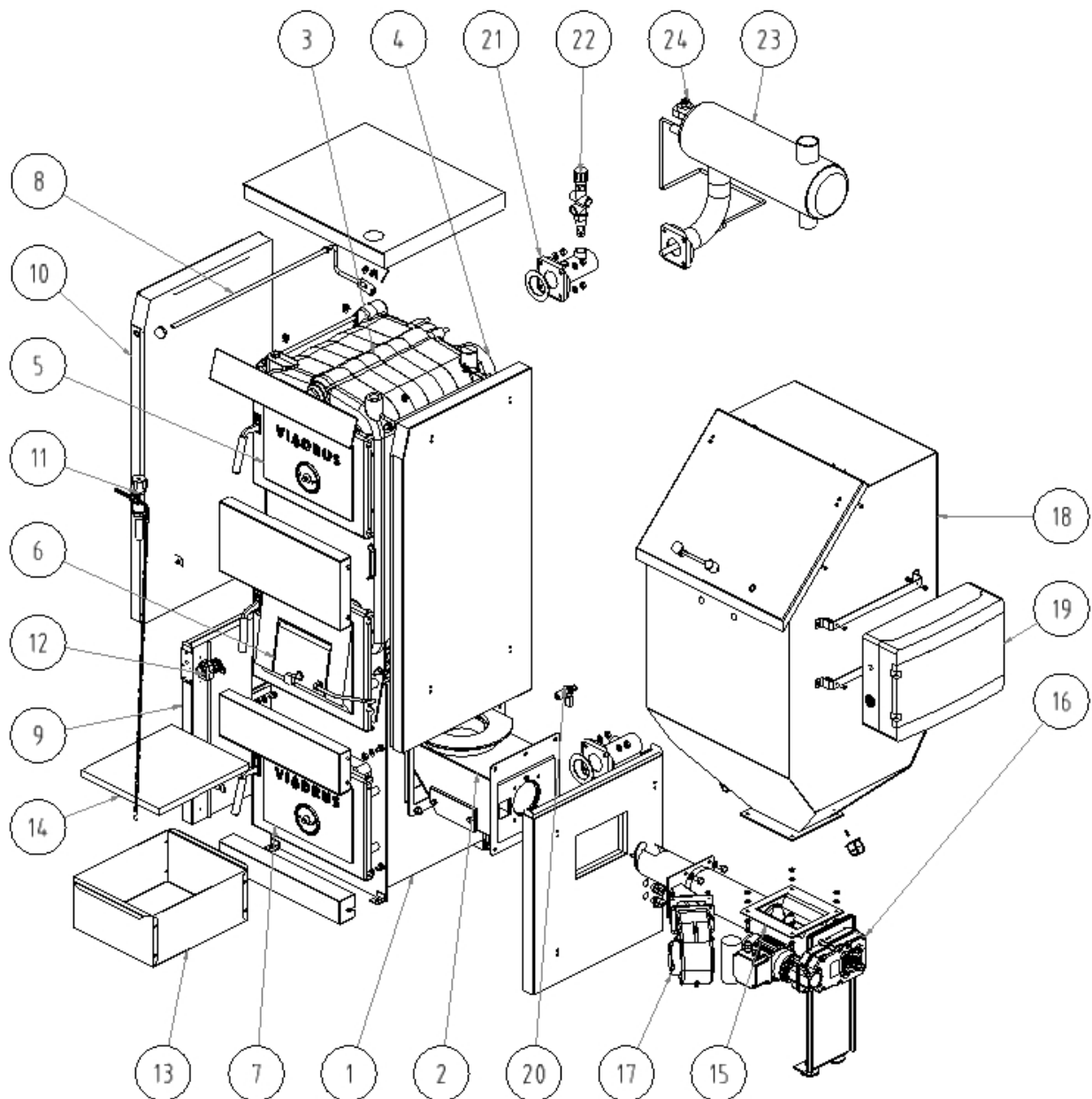

- | | |
|--|--|
| 1 – Basement | 13 – Ash-pan (Automatic operation) |
| 2 – Burner | 14 – Insulation under the drawer |
| 3 – Boiler drum | 15 – Fuel feeder |
| 4 – Smoke adapter | 16 – Geared engine |
| 5 – Stoking door (Manual operation) | 17 – Ventilator |
| 6 – Ash-pan door (Manual operation) | 18 – Fuel reservoir |
| 7 – Ash-pan door (Automatic operation) | 19 – Service board |
| 8 – Smoke control draw rod | 20 – Filling and drain taps G ½" |
| 9 – Basement shell | 21 – Heating a return water flanges |
| 10 – Boiler drum shell incl. ash-pan | 22 – Valve DBV 1 – 02 |
| 11 – Draught regulator | 23 – After-cooling loop |
| 12 – Safety thermostat | 24 – Thermostatic valve BVTS or TS 130 or STS 20 |

Fig. no. 3 Main components of VIADRUS HERCULES DUO boiler

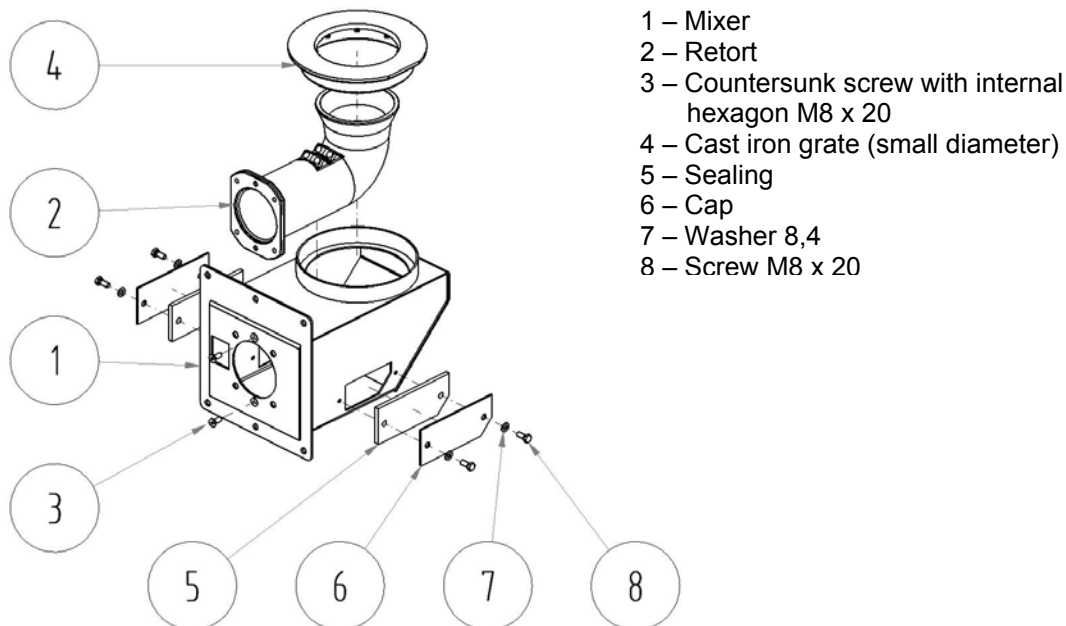

Fig. no. 4 Burner with mixer (fuel – lignite and hard coal)

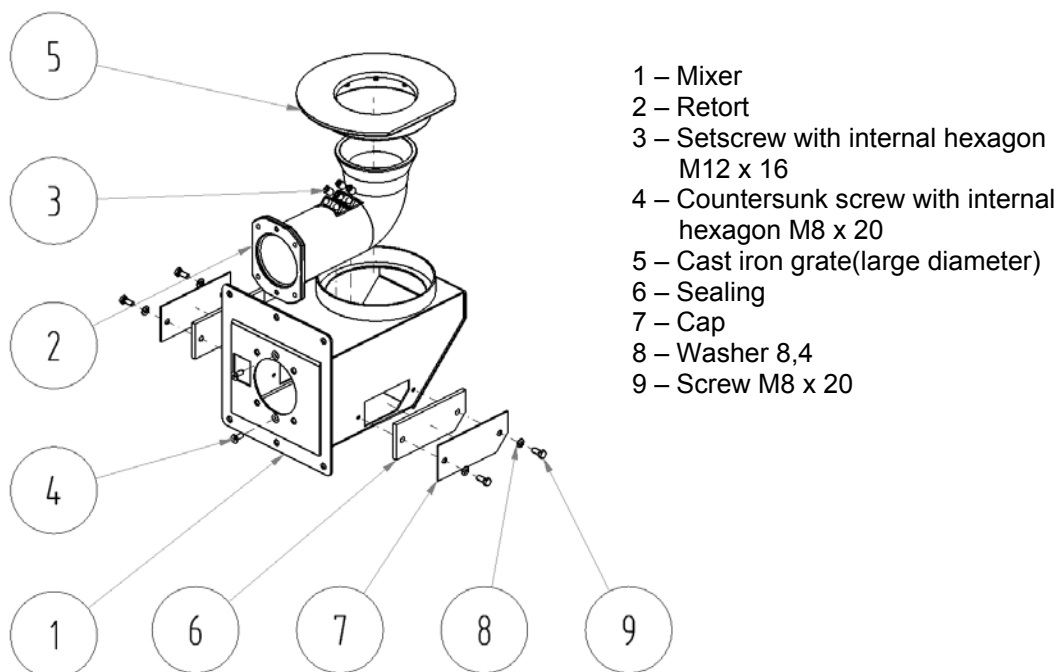

Fig. no. 5 Burner with mixer (fuel – wood pellets)

4. Positioning and installation

4.1 Regulations and directives

The solid fuel boiler can only be installed by a company holding a valid license for boiler installation and maintenance.

The project according to valid regulations must be elaborated for installation.

The heating system must be filled with water that meets the requirements of ČSN 07 7401 and especially its hardness must not exceed the desired parameters.

Recommended values		
Hardness	mmol/l	1
Ca ²⁺	mmol/l	0,3
Total Fe + Mn concentration	mg/l	(0,3)*

*) recommended value

WARNING!!! The use of anti-freeze mixture is not recommended by the manufacturer.

In case of two-way safety device response regarding the water refill permit in case the water does not conform to ČSN 07 7401 it is necessary to treat water in system so that it again conforms to this standard.

a) regarding the heating system

ČSN 06 0310	Thermal systems in buildings – Design and installation
ČSN 06 0830	Thermal systems in buildings – Protecting devices
ČSN 07 7401	Water and steam for thermal energetic devices with steam working pressure up to 8 MPa.
EN 303-5	Boilers for central heating – Part 5: Solid fuel boilers for central heating with manual or automatic feed and max. 300 kW nominal thermal output: terminology, requirements, testing and marking.

b) regarding the chimney

ČSN 73 4201	Designing the chimneys and smoke flues
-------------	--

c) regarding the fire regulations

ČSN 06 1008	Fire safety of thermal equipments
EN 13 501-1	Fire properties of materials; combustibility grades of building materials

d) regarding the electric network

ČSN 33 0165	Electrical regulations; marking the leading wires by colours or digits; implementing regulations
ČSN 33 1500	Electrical regulations; revision of electrical equipments
ČSN 33 2000-3	Electrical regulations; electrical equipments Part 3: Setting the basic characteristics.
ČSN 33 2000-4-41	Electrical equipments: part 4: Safety chap. 41: Protection against electric shock
ČSN 33 2000-5-51 ed. 2	Electrical regulations: Electrical equipments construction
ČSN 33 2130	Electrical regulations: Internal electricity distribution
ČSN 33 2180	Electrical regulations: Connection of electric instruments and appliances
ČSN 34 0350	Electrical regulations: Regulations for flexible cords and cord lines
EN 60 079-10	Electrical regulations: Regulations for electrical equipments at the places with explosion hazard with flammable gases and vapours.
EN 60 252-1	Capacitors for AC motors – Part 1: In general – Design, testing, dimensioning – Safety requirements – Instructions for installation and operation.
EN 60 335-1 ed.2	Electric appliances for household and similar purposes – Safety – Part 1: General requirements
EN 60 335-2-102	Electric appliances for household and similar purposes – Safety – Part 2-102: Special demands on appliances containing the electric connections and burning the gas, oil and solid fuels
EN 60 445 ed. 3	Basic and safety principles for man – machine interface, marking and identification
EN 60 446	Basic and safety principles of machinery operation - Marking the leading wires with colours or digits
EN 61000 – 6 – 3	EMC – Part 6 – 3: Basic standards – Emissions – residential, commercial and light industry environment.
EN 61000 -3 – 2	EMC - Part 3 – 2: Limits – Limits for harmonic currents emissions (device with input phase current up to 16 A inclusive).
EN 61000 – 3 –3	EMC – Part 3 - Limits - section 3: Specifies the limitation of voltage fluctuation and flicker in low-voltage supply systems for equipment with a rated input current greater than 16 A.

e) regarding the system for HW heating

ČSN 06 0320	Thermal systems in buildings– Hot water preparation– Design and project engineering
ČSN 06 0830	Thermal systems in buildings – Protecting devices
ČSN 73 6660	Internal water piping

4.2 Positioning options

The boiler is equipped with the movable mains supply and plug. Boiler according to EN 60 335–1 ed. 2 Art. 7.12.4 must be positioned in such a way that the plug is accessible.

Boiler positioning with regard to fire regulations:

11. Positioning on the floor made of incombustible material

- put the boiler on a fireproof and heat-insulating pad exceeding the boiler plan by 20 mm on the sides;
- In case the boiler is installed in a cellar it should be put on a minimum 50 mm high substructure. The boiler must stand horizontally and possible unevenness of the substructure is eliminated by means of adjusting screw of the engine bed

Tab. no. 6 Combustibility grade of building materials and products

Combustibility grade of building materials and products	Building materials and products ranked in combustibility grade (EN 13 501-1 selection)
A – incombustible	Granite, sandstone, concrete, bricks, ceramic tiles, mortars, fireproof plasters,....
B – combustible with difficulty	Acumin, izumin, heraklit, lignos, boards and basalt wools, fiberglass boards,...
C₁ – hardly combustible	Beech and oak wood, hobrex boards, plywood, werzalit, formica, sirkolit,...
C₂ – medium combustible	Pinewood, larch, whitewood, chipboard and cork boards, rubber flooring,.
C₃ – easily combustible	asphalt boards, fireboards, cellulous materials, polyurethane, polystyrene, polyethylene, PVC,....

2. Safety distance from the combustible materials

- When installing and operating the boiler it is necessary to keep a safety distance 200 mm from combustible materials with combustibility grade B, C₁ and C₂ (ČSN 06 1008);
- For easily combustible materials with combustibility grade C₃, which burn quickly and by themselves also after the ignition source removal (e.g. paper, millboard, stiff paper, asphalt and tar boards, wood and fireboards, plastics and flooring materials) the safety distance is doubled, it means to 400 mm;
- The safety distance must be doubled also in case the combustibility grade of building material wasn't proved.

Boiler positioning with regard to the necessary handling space:

- basic environment AA5/AB5 according to ČSN 33 2000-3;
- min. 1000 mm handling space must be left in front of the boiler;
- minimum distance between the boiler rear side and wall is 400 mm;
- a gap min. 1000 mm is left on the side of fuel reservoir in case of feed screwremoval;
- minimum distance from the side wall is 100 mm;
- at least 450 mm are left above the boiler.

Boiler positioning with regard to electrical network(mains):

- The boiler must be placed in such a way that the plug in socket (230V/50Hz) is always accessible.

Placing of fuel:

- **Dry fuel has to be used in order to ensure its proper burning in the boiler.** Fuel stored in cellar or at least sheltered is recommended by the manufacturer;
- It is out of the question to store fuel behind the boiler or next to the boiler in the distance shorter than 400 mm;
- Min. 1 000 mm distance kept between the boiler and fuel is recommended by the manufacturer or the fuel has to be stored in a room separated from the boiler-room.

The boiler-room must be permanently supplied with the air both for burning and ventilation (**VIADRUS HERCULES DUO** boiler air consumption is approx. 75 m³. h⁻¹).

The heating system piping or heater heating element piping must be connected by the qualified person.

WARNING: When connecting the boiler to the heating system the drain tap must be installed at the lowest point and closest possible to the boiler.

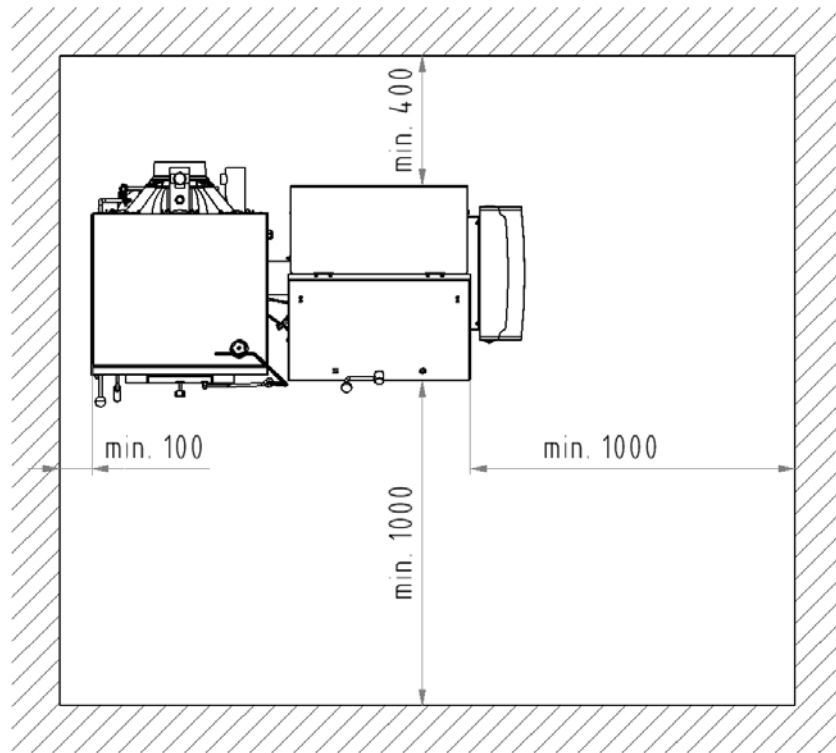

Fig. no. 6 VIADRUS HERCULES DUO boiler positioning in the boiler-room

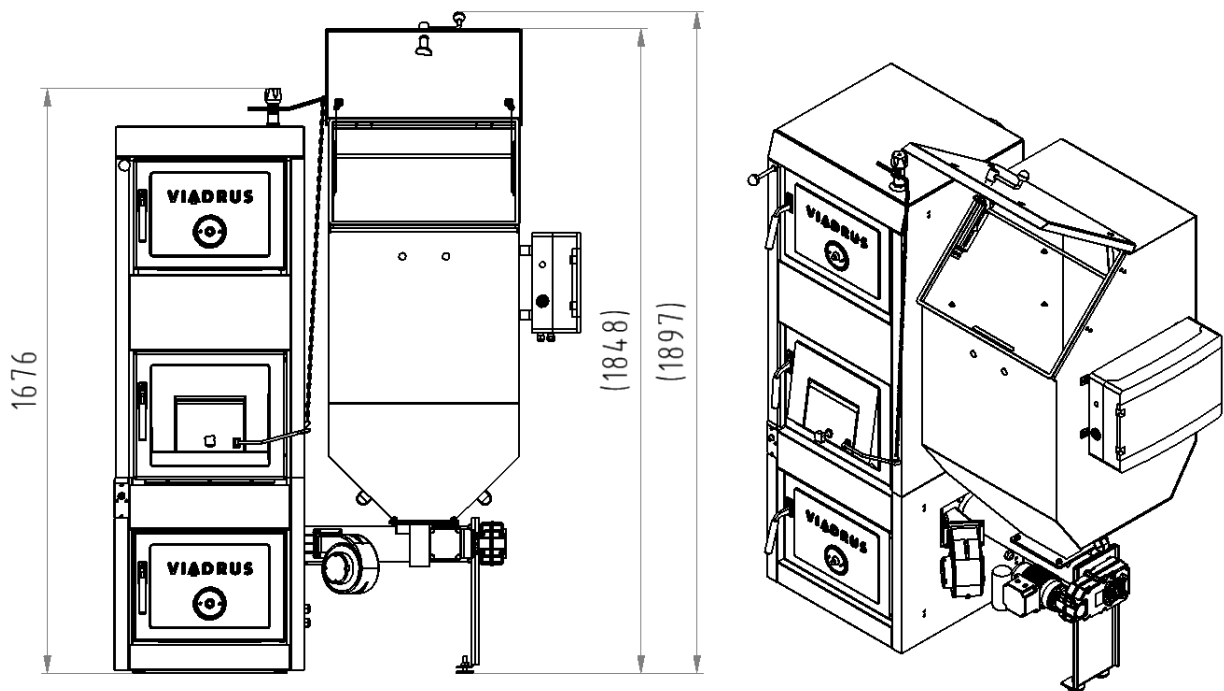

Fig. no. 7 Boiler VIADRUS HERCULES DUO (right-hand design with small reservoir) with open fuel reservoir

4.3 Hydraulic connection diagram

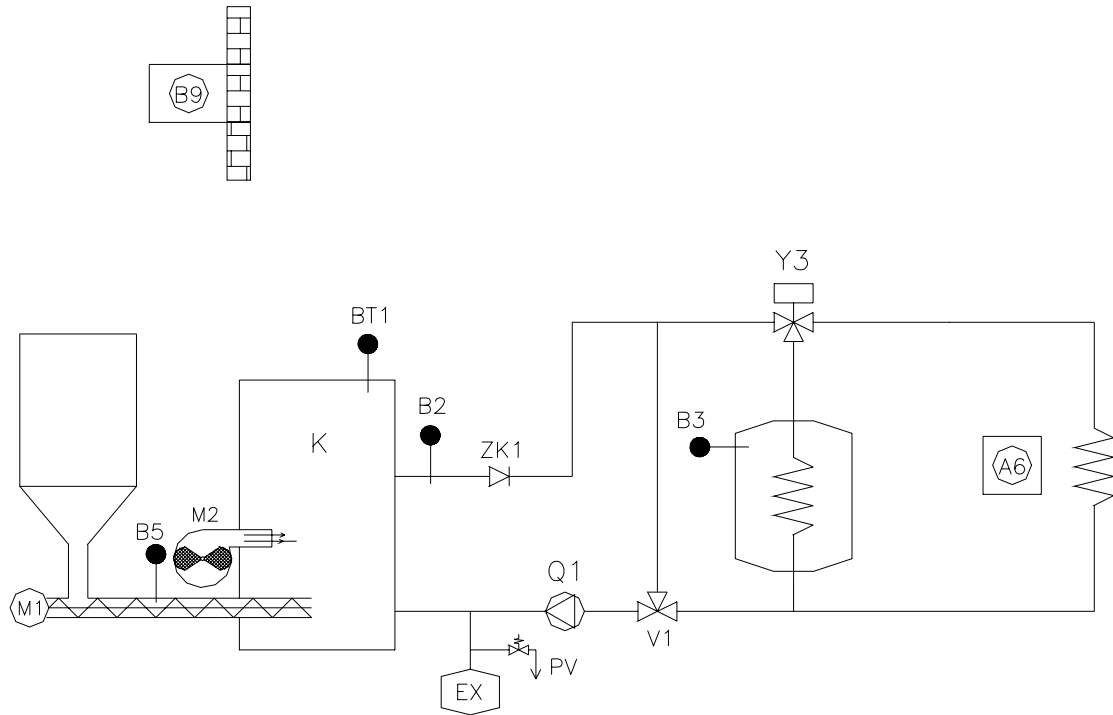

Fig. no. 8 Hydraulic diagram with HW preparation– Pump heating circuit

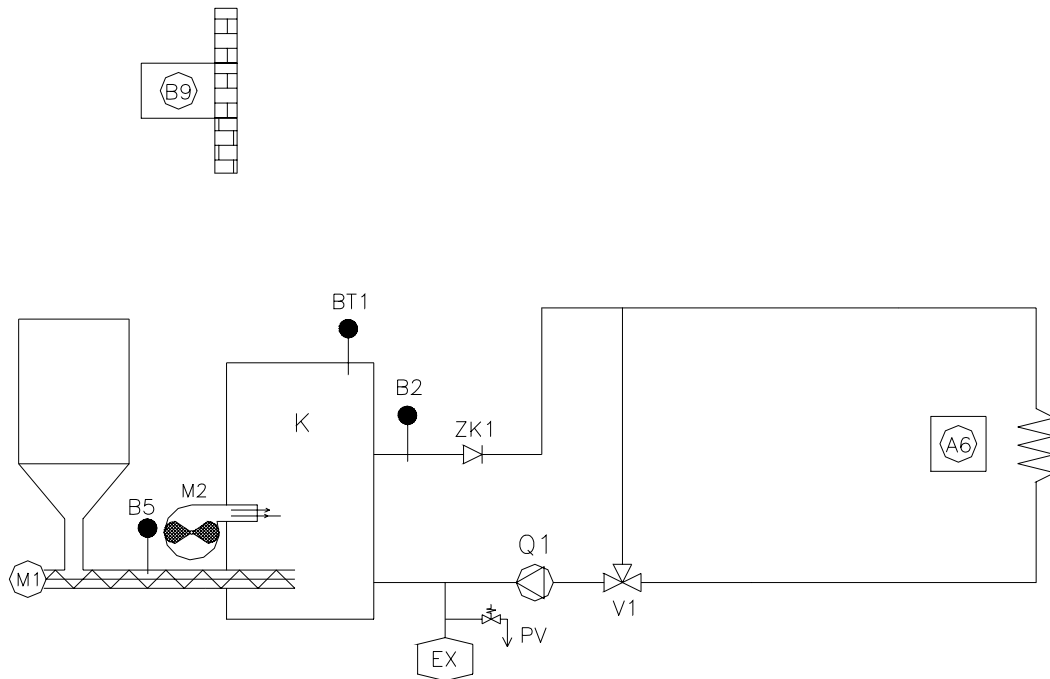

Fig. no. 9 Hydraulic diagram without HW preparation– Pump heating circuit

Legend to Fig. no. 8 and 9:

A6	QAA 88 device	M1	Fuel feeder motor
BT1	Safety thermostat	M2	Air fanmotor
B2	Boiler outlet temperature sensor	PV	Safety valve
B3	HW temperature sensor	Q1	Boiler primary circuit pump
B5	Fuel feeder temperature sensor	Y3	HW heating three-way valve
B9	Outside temperature sensor	V1	Thermostatic valve
EX	Expansion vessel	ZK	Clack valve

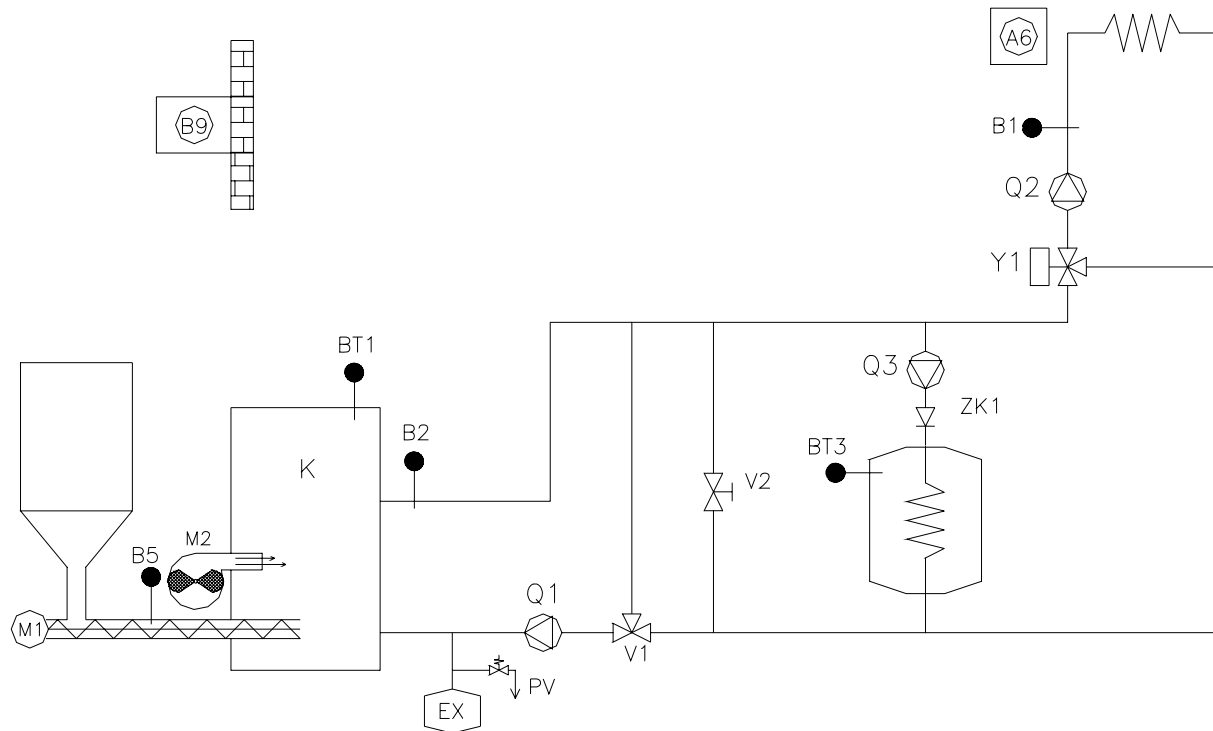

Fig. no. 10 Hydraulic diagram with HW preparation– Mixing heating circuit

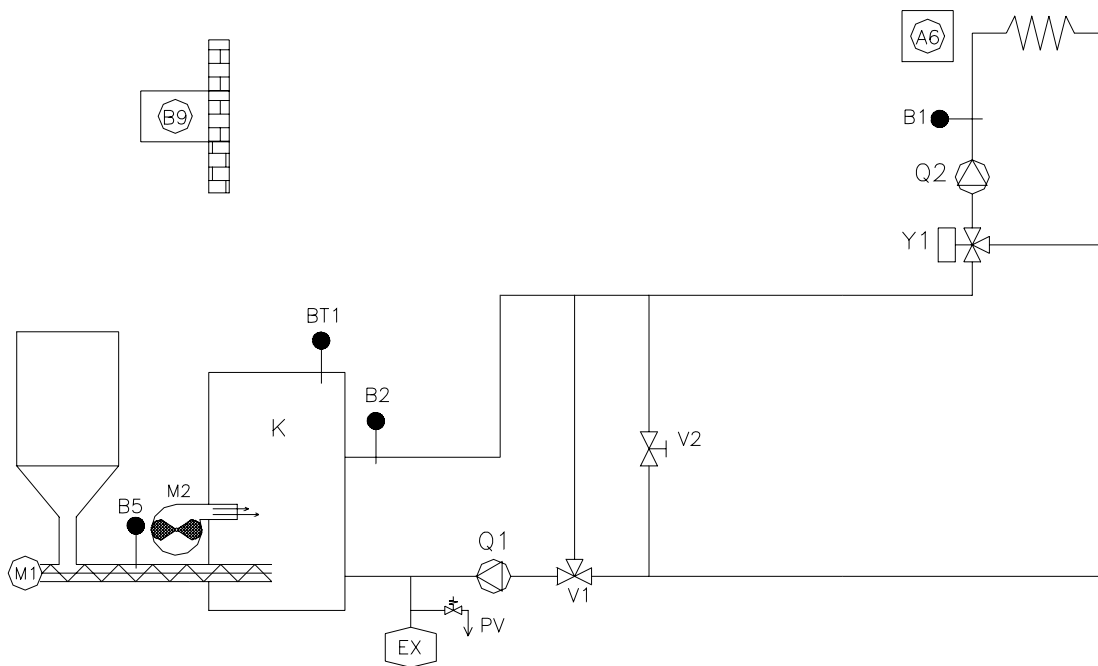

Fig. no. 11 Hydraulic diagram without HW preparation– Mixing heating circuit

Legend to figures no. 10 and 11:

A6	QAA 88 device	PV	Safety valve
BT1	Safety thermostat	Q1	Boiler primary circuit pump
BT3	Thermostat HW	Q2	Heating circuit pump
B1	Heating branch temperature sensor	Q3	HW charging pump
B2	Boiler outlet temperature sensor	Y1	Heating circuit three-way mixing valve drive
B5	Fuel feeder temperature sensor	V1	Thermostatic valve
B9	Outside temperature sensor	V2	Stop valve
EX	Expansion vessel	ZK1	Clack valve
M1	Fuel feeder motor		
M2	Air fan motor		

Note:

Select the dimension of shorting pipe with stop valve V2 up to the half of other piping dimension. Shorting pipe is necessary. In case the thermostatic valve V1 is only closed through the boiler and mixing valve Y1 is open to the heating circuit the heating circuit with the heating circuit pump will be secured through this shorting pipe.

Sensor cables can anyhow be shortened or prolonged provided following principles are observed:

- do not cut the sensor cable in the distance shorter than 0,5 m from the jacket;
- cable sensor prolongation by more than 10 m is not recommended;
- CMSM – H 2 x 0,5 mm cable is recommended for cable prolongation;
- Cable connection in case of prolongation is to be done very carefully. Ensure the conductive joint when you shorten or prolong the cable.

Note to the three-way valve V4044C (V4044F) made by Honeywell:

Connection AB –heating water outlet from boiler

Connection A – outlet to the water heater

Connection B – outlet to the heating circuit

Note to the three-way mixing valve VBI31.20 with drive SQK34.00 (Siemens):

After the connection of the three-way mixing valve it is necessary to check whether the valve opens in case heating is required. If it be to the contrary revert the phases L (Y1) and L1 (Y2). It is also important to observe the correct hydraulic connection of three-way mixing valve according to the enclosed manual.

Recommendation for the check!

Select the value 4 in P 20 parameter which means boiler manual operation. At this type of operation HMI ACX84.910 ALG service unit displays the word Wood.

Three-way mixing valve must open up to maximum into the heating circuit.

Floor heating

Floor heating can be used in mixing heating circuit. Following parameters have to be set:

- Parameter P 21 – Slope of heating curve to the value 0,8,
- Parameter P 76 – Minimum temperature of heating circuit (can be reduced to the value of 20 °C),
- Parameter P 77 – Maximum temperature of heating circuit max. 40 °C.

In case of superfluous heat withdrawal into the heating circuit the temperature will be mixed to the maximum set temperature of the heating circuit.

Note:

In case of radiators and floor heating combination the floor heating must have its own regulation including the three-way mixing valve.

5. Boiler installation

5.1 Delivery and accessories

VIADRUS HERCULES DUO boiler based on the order is delivered in such a way that the complete boiler drum including the basement is put on the pallet and packed boiler shell is gripped at the side of it. The accessories are put inside the boiler drum and are accessible after opening the stoking door. The fuel reservoir (depending on the requirement small – 269 dm³ or large – 528 dm³) including the fuel feeder set is put on another pallet. The boiler is packed in transport package and must not be tipped over during the transport.

Standard boiler delivery:

- boiler drum with basement
- fuel feeder set
- fuel reservoir
- service board SIMBOX WP 8GB1 373-3 – set incl. electric pack
- QAA 88 device
- insulation under the drawer
- ventilator
- round head screw and cross-recessed screw M6 x 16 (4 pc) for ventilator gripping to the feeder flange
- washer 6,4 (4 pc) to ventilator gripping to the feeder flange
- nut M6 (4 pc) to ventilator gripping to the feeder flange

- Safety thermostat
- round head screw and cross-recessed screw M4 x 6 (2 pc) for safety thermostat gripping
- boiler drum shell incl. ash-pan – manual regime
- connection accessories for boiler drum shell (spring clip – 4 pc, junction stud – 4 pc, screw ST4,8 x 13 – 10 pc)
- basement shell
- connection accessories for basement shell (screw ST 4,2 x 9,5 – 4 pc, screw ST 4,8 x 13 – 8pc)
- connection accessories for basement shell gripping to the basement (washer 8,4 – 4 pc, nut M8 – 4 pc)
- ash-pan – automatic regime
- boiler mastic – tube 310 ml
- spacing fastener (2 pc)
- screws ST 4,8 x 13 (2 pc) for spacing fasteners gripping
- bushings PG 13,5 (2 pc)
- bushings PG 11 (2 pc)
- hexagon head screws M10 x 30 (4 pc) and washers 10 (4 pc) for gripping the fuel feeder set to the basement
- hexagon head screws M8 x 20 (4 pc) and washers 8 (4 pc) for gripping the fuel reservoir to the fuel feeder
- filling and drain tap Js 1/2" (1 pc)
- draught regulator complete (1 pc)
- plug Js 6/4" blind (1 pc)
- sealing ϕ 60 x 48 x 2 (1 pc)
- choker screw (1 pc)
- draw rod with hanaccording to for smoke flap control (1 pc)
- grommet HEYCO (2 pc)
- label for smoke flap control (1 pc)
- flange of heating and return water 2" (2 pc)
- sealing ϕ 90 x 60 x 3 (2 pc)
- handling key (1 pc)
- cleaning tools (hook, brush with hanaccording to, tang, dowel 8 mm – 2 pc, straight threaded rivet 5x60 – 2 pc)
- boiler service and installation manual incl. the certificate of warranty
- list of contractual service organizations
- siseal 10 g
- thermostatic valve BVTS (Danfoss) or TS 130 (Honeywell) or STS 20 (Watts)
- cast iron grate (large diameter)
- set inbus screw M12 x 16 (4 pc)
- boiler sensor QAZ 36.526/109
- sensor against fuel fire penetration QAZ 36.526/109
- outside sensor QAC 34/101 (necessary for the full and basic version for equithermal control)
- thermostatic valve (filling valve) - series VTC312 (external thread) made by ESBE (minimum temperature of return water is 45 °C) (ord. code: 5100 15 00)

Obligatory accessories for mixing heating circuit (not included in the delivery):

- Heating branch sensor QAD 36/101 (Siemens)
- Three-way mixing valve VBI31.20 with drive SQK34.00 (Siemens)
- Water heater thermostat type: 7K1.6R326.00A (capillary length: 1000 mm, range: 0 - 60 oC) (in case boiler will be used for HW heating)

Obligatory accessories for pump heating circuit (not included in the delivery):

- Hot water sensor QAZ36.526/109 (in case boiler will be used for HW heating) (Siemens)
- Three-way valve V4044F (in case boiler will be used for HW heating) (Honeywell). – in this case only the phase, working and protective conductors will be connected. Note: also V4044C valve can be used.

Obligatory accessories (not included in the delivery):

- After-cooling loop (1pc) incl. flange or two-way safety valve DBV 1 – 02 incl. siseal (10 g). This equipment needn't be used in case of open heating system.
- Thermostatic valve BVTS (Danfoss) or TS 130 (Honeywell) or STS 20 (Watts) TV 95 °C – can be bought in warehouses (only in case of delivery with after- cooling loop)
- Safety valve (1 pc) according to the maximum boiler operating overpressure (see tab. no. 1)

By request:

- HMI (ACX84.910/ALG) service unit for Saphir regulator operation – Siemens
- Circulating pump Grundfos UPS 25-40
- Water heater (according to VIADRUS offer)
- Pressure gauge type 50 (400 kPa) with rear connection by Regulus
- Thermometer type 63 with rear connection by Regulus
- Filter 3/4" (for boiler with two-way safety valve DBV 1 – 02)

Supplementary accessories (not included in the delivery):

- | | |
|--|------|
| • ceramic liner for coal combustion | 1 pc |
| • suspension desk | 1 pc |
| • additional grate for wood combustion | 2 pc |

The boiler equipment ordered as „obligatory accessories“ and „by request“ is not included in the basic price of boiler.

5.2 Installation procedure

Installation of boiler drum with the basement – after- cooling loop

1. Position the boiler drum with basement on the substructure (pad) into the horizontal position.
2. First of all weld the flange of heating water after-cooling loop on the after-cooling loop weldment (follow the boiler-room dispositions), put the sealing between the flange and boiler and then mount the weldment by means of four screws to the boiler. By welding connect the upper heating water outlet with the heating system.
3. Connect the after-cooling loop lower outlet by welding the 1 1/2" pipe with return water inlet (return water flange) to the boiler. Then by welding connect the flange with heating system return water.
4. Mount the thermostatic valve on one of the after-cooling loop outlets (mount the sensor into the basin and connect the 1/2" cold water inlet). Pay attention to marking the water flow direction by means of arrow; the direction must be identical according to Fig. no. 29.
5. Connect the other 1/2" after-cooling loop outlet with drain (warning: the water outlet connection with the drain by means of a funnel is recommended in order to check the thermostatic valve function).
6. After the boiler has been connected to the heating system screw the drain valve into the boiler at the rear of the basement.
7. Put the stove-pipe on the smoke adapter and insert into chimney hole. The stove-pipe diameter is 160 mm.
8. Screw the draught regulator into the hole in the upper part of the front section. The draught regulator setting procedure is described in the manual enclosed to the regulator. Blind the threaded hole JS 6/4" in the front section with plug JS 6/4". Put the sealing under the plug.
9. The use of stop valves at the heating water inlet and outlet is recommended because without these valves the whole system will have to be emptied in case of filter cleaning.

Installation of boiler drum with basement – two-way safety valve DBV 1 -02

1. Position the boiler drum with basement on the substructure (pad) into the horizontal position.
2. Insert the sealing between the heating water flange and boiler, then mount by means of four screws to the boiler (follow the boiler-room dispositions). By welding connect the heating water outlet with the heating system.
3. Insert the sealing between the return water flange and boiler, then mount by means of four screws to the boiler. By welding connect the lower return water outlet with the heating system.
4. According to Fig. no. 32 interconnect the two-way safety valve DBV 1 – 02 with return and heating water flange with cooling water inlet and superfluous heat outlet.
5. Mount the drain valve into the hole at the rear of the basement.
6. Put the stove-pipe on the smoke adapter and insert into chimney hole. The stove-pipe diameter is 160 mm.
7. Screw the draught regulator into the hole in the upper part of the front section. The draught regulator setting procedure is described in the manual enclosed to the regulator.
8. Blind the threaded hole JS 6/4" in the front section with plug JS 6/4". Put the sealing under the plug.
9. The use of stop valves at the heating water inlet and outlet is recommended because without these valves the whole system will have to be emptied in case of filter cleaning.

Shells assembly

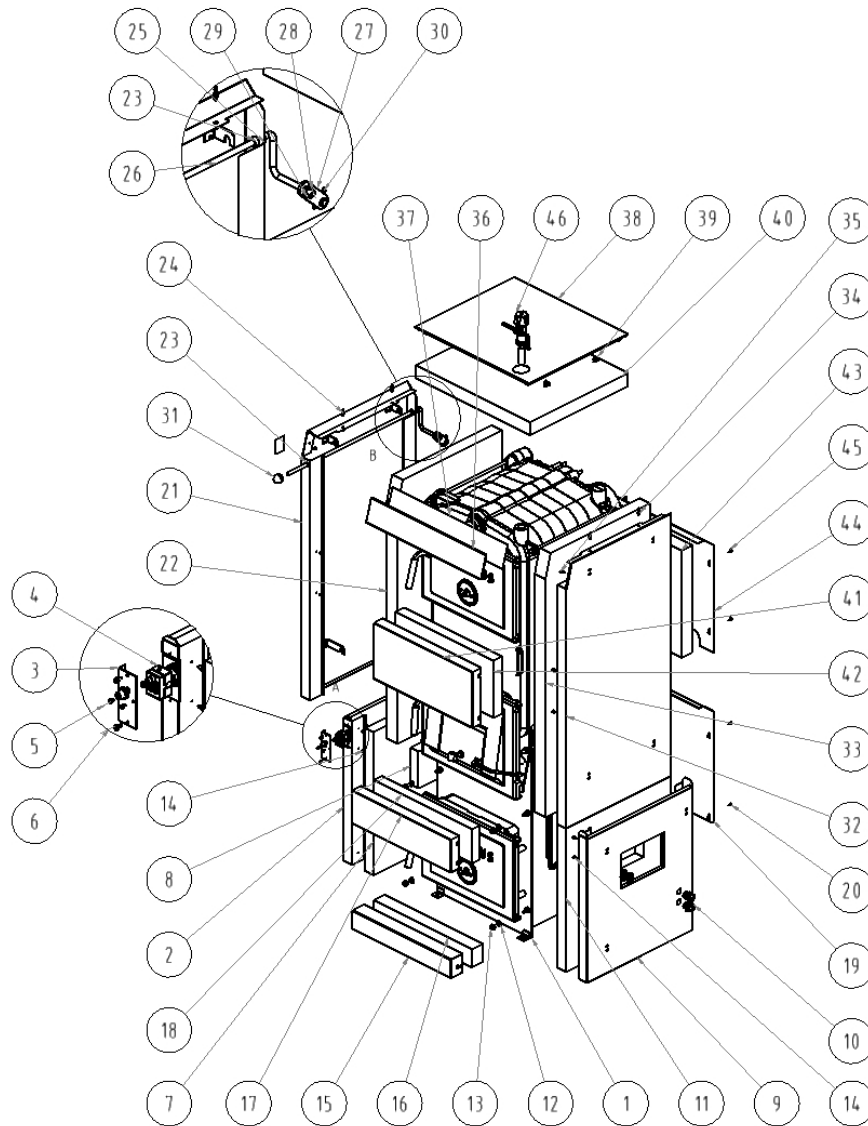

- | | |
|---|--|
| 1 – Boiler drum 4 sec. with basement | 25 – Washer 10,5 (1 pc) |
| 2 – Left side part of basement shell | 26 – Draw rod of smoke control |
| 3 – Safety thermostat holder | 27 – Control mechanism lever |
| 4 – Safety thermostat | 28 – Washer 10,5 (1 pc) |
| 5 – Screw M4 x 6 (2 pc) | 29 – Plug $\varnothing 3 \times 25$ (1 pc) |
| 6 – Screw ST 4,8 x 13 (2 pc) | 30 – Lock 2,5 x 32 (1 pc) |
| 7 – Insulation of left side part of basement shell | 31 – Bakelite ball |
| 8 – Insulation into cut-out | 32 – Right side part of the shell |
| 9 – Right side part of basement shell | 33 – Side part of the shell insulation |
| 10 – Bushing PG 13,5 (2 pc) | 34 – Junction stud (2 pc) |
| 11 – Insulation of left side part of basement shell | 35 – Screw ST 4,8 x 13 (6 pc) |
| 12 – Washer 8,4 (4 pc) | 36 – Face |
| 13 – Nut M8 (4 pc) | 37 – Face insulation |
| 14 – Screw ST 4,8 x 13 (4 pc) | 38 – Upper part of the shell |
| 15 – Front lower part of shell | 39 – Spring clip (4 pc) |
| 16 – Front lower part of the shell insulation | 40 – Upper part of the shell insulation |
| 17 – Front upper part of shell | 41 – Front part of the shell |
| 18 – Front upper part of the shell insulation | 42 – Front part of the shell insulation |
| 19 – Rear part of shell | 43 – Rear part of the shell insulation |
| 20 – Screw ST 4,2 x 9,5 (4 pc) | 44 – Rear part of the shell |
| 21 – Left side part of the shell | 45 – Screw ST 4,8 x 13 |
| 22 – Side part of the shell insulation | 46 – Draught regulator |
| 23 – Grommet Hezci | |
| 24 – Junction stud (2 pc) | |

Fig. no. 12 Boiler shell

1. Remove the shell from the cardboard package.
2. Mount the relevant connection accessories on the steel sheet components according to Fig. no. 12.
3. Jacket the **VIADRUS HERCULES DUO** boiler according to Fig. no. 12.
4. Screw the safety thermostat (2 pc screw M4 x 6) to the safety thermostat holder. Screw the holder with the safety thermostat to the left shell of basement (2 pc screw ST 4,8 x 13) – see detail A. (Note: lead the safety thermostat capillary between the shell and insulation). The electric connection of safety thermostat is done before jacketing the boiler. The cable goes in the bushing through the side part of the basement shell depending on the design either in the left or right part of basement shell. The boiler output temperature sensor must be positioned in the boiler basin across the bushing in the side part of the basement shell (depending on the right or left design) also before the boiler jacketing.
5. Mount the left and right side part of basement shell incl. insulation. Depending on the left or right design selection break out the steel sheet for feeder connection. Grip the side parts to the basement by means of M8 nuts and 8,4 washers (only to the front part of the basement).
6. Mount the front parts of basement shell incl. insulation (upper and lower) and screw the rear part of basement shell to the side parts of basement shell.
7. Mount the left and right side part of shell incl. insulation to the anchor screws (screw the junction studs into both side parts of shells and mount the HEYCO bushings in the left shell).
8. Pull the smoke control draw rod through the left side part of the shell and secure by a plug. Mount the smoke control lever on the draw rod and secure by means of 2 pc washers and plugs. Connect the smoke control lever with smoke adapter flap and secure with a lock; the screw the bakelite ball
9. Stick the label for signalling the smoke flap on the left-hand side part of the shell at the point of smoke control draw rod.
10. Mount the front part of the shell incl. insulation.
11. Screw the rear part of the shell to the side parts.
12. Seat the face with insulation on the side parts.
13. Insert the spring clips into the upper part of shell with insulation and mount on junction studs of shell side parts.

Fuel reservoir assembly

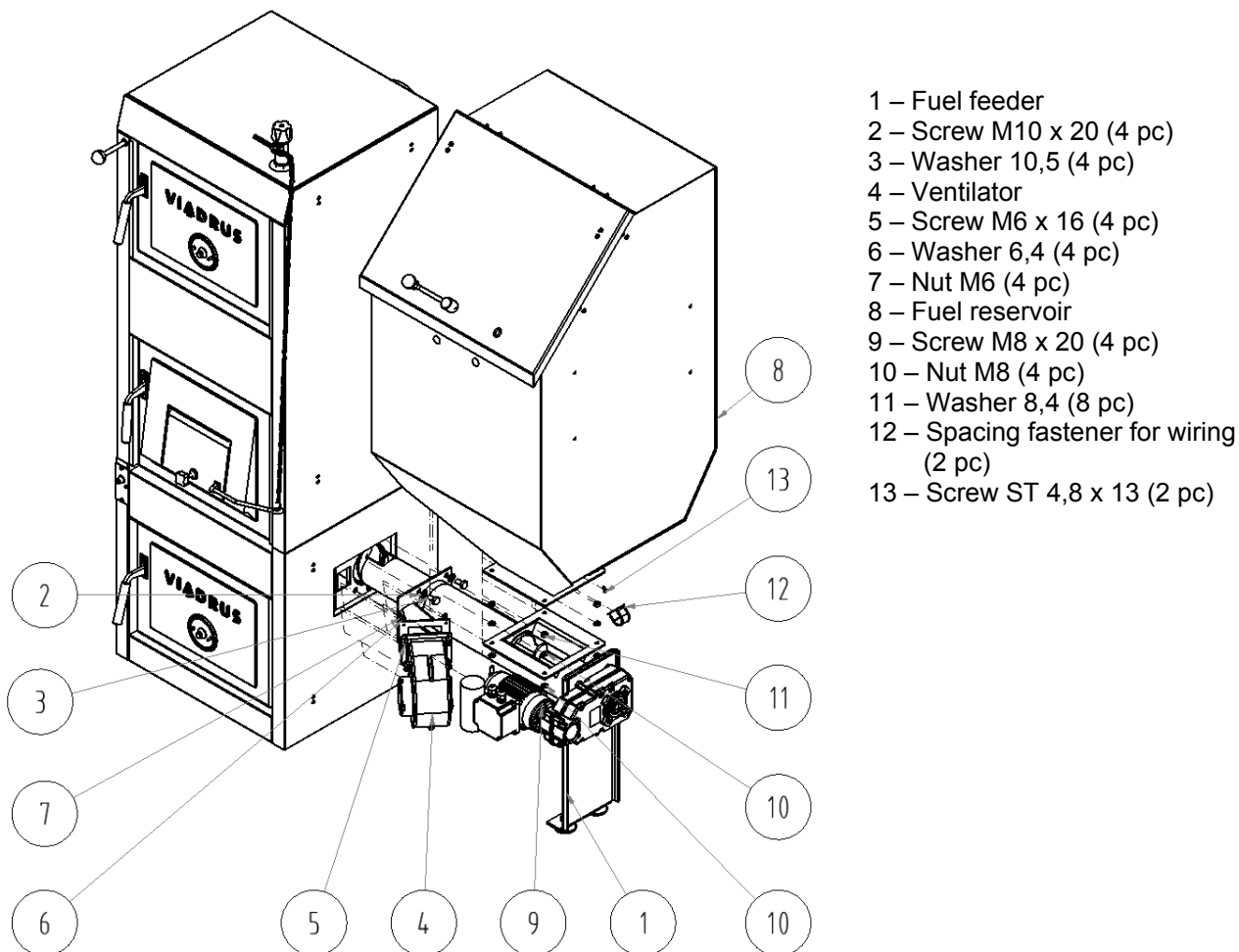

Fig. no. 13 Mounting of fuel feeder and reservoir to the boiler

Warning:

In case of mounting the fuel feeder to the basement and fuel reservoir to the fuel feeder we first of all position all components into horizontal position and then finally tighten the screws and nuts

Apply mastic to the boiler basement and then mount the fuel conveyer to the boiler basement. Then mount the ventilator.

Apply mastic fuel to the conveyer set to the point of fuel reservoir bearing surface. Position the fuel reservoir and tighten the screws.

Fasten the spacing fasteners for wiring to the fuel reservoir.

ATTENTION!!! Before the fuel reservoir is loaded with fuel it is necessary to check the free rotation of fuel feed screw.

Mounting of the service board to the fuel reservoir

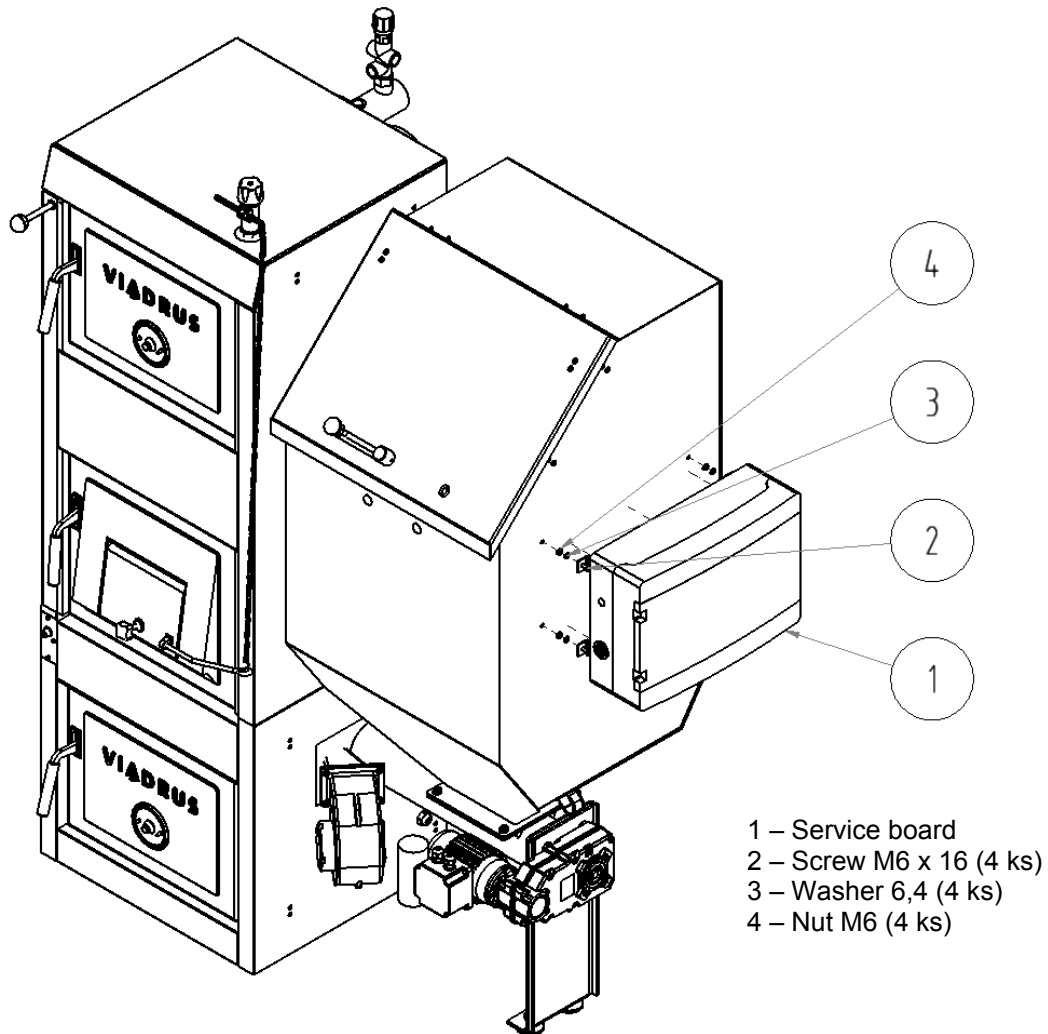

Fig. no. 14 Mounting of the service board to the fuel reservoir

Screw the service board to the side of fuel reservoir.

Carry out the wiring system according to diagram in chap. 5.2.4. Lead the cables by means of spacing fasteners gripped to the side of fuel reservoir.

Mounting of cleaning tools

The ordinary assembly tools and leather gloves are to be used for mounting and demounting of the brush and spike on tang (if it is included in the delivery).

Mounting of emergency fire extinguishing equipment

In the cleaning hole cover there is a pipe for water inlet with 1/2" connection that serves for BVTs valve or TS 130 or STS 20 interconnection. The interconnection can be carried out by means of flexible(stainless) hose. On the ground of possible disassembly it must regard the demountable connection of valve with the

pipe in the cleaning hole cover. The valve sensor is to be positioned in the sensor holder that is on the fuel feeder.

Note: The valve sensor is to be positioned in the sensor holder without the valve basin that is included in the delivery.

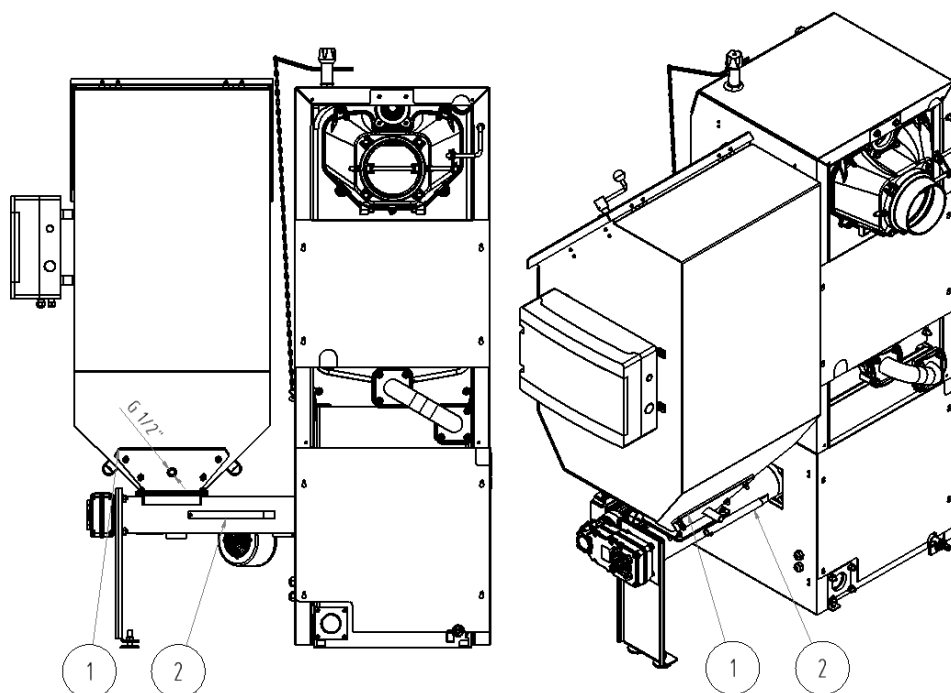

1 – Cleaning hole cover
2 – Sensor holder

Fig. no. 15 Mounting of emergency fire-extinguishing equipment

Emergency fire-extinguishing equipment function:

In case of fuel fire penetration into feeder (temperature in feeder has reached 95 °C), BVTS or TS 130 or STS 20 valve opens the cold water inlet into hopper and the burning fuel is extinguished. After the temperature on the sensor has dropped by 6 °C the water supply is stopped. Then it is necessary to dismount the motor with worm shaft and stainless insert and do cleaning. This is followed by the re-assembly and check whether the valve does not let flowing the cold water into the reservoir; if yes exchange the valve.

5.2.1 Boiler conversion when switching over from automatic to manual operation

- Switch off the boiler by means of on/off key.
- Put the fuel feeder into operation for the essentially necessary period of time (manual regime – green button) until the burning fuel is transferred into the ash-pan.
- Put the insulation and ash-pan (small) on the retort. The insulation under the drawer serves against the ash sifting into burner with mixer.
- The boiler door including the fuel reservoir cover must be carefully closed during the boiler operation.
- Check whether the flap in smoke adapter is open.
- Mount the draught regulator chain on the choker and adjust after the boiler has flared up (according to the manual supplied by draught regulator manufacture).
- On QAA 88 device select value 4 (Manual operation) in P 20 parameter. HMI ACX84.910 ALG service unit at this type of boiler operation will display the word Wood.
- We make fire according to chap. 7.4.

5.2.2 Boiler conversion when switching over from manual to automatic operation

- Let the fuel burn out and clear the boiler of ash and solid combustion residues.
- Pull out the insulation and ash-pan positioned above the burner.
- Disconnect the draught regulator chain from the choker. The draught regulator chain must be positioned in such a way that the unwanted choker regulation cannot happen.
- Check whether the chimney flap is open.
- Select the required fuel in P 20 parameter on QAA 8 device.
- Make fire according to chap. 6.7.

5.2.3 Boiler conversion from right-hand design to the left-hand design

Boiler conversion after delivery before installation:

- We remove the grate and pull out the burner with mixer from the basement (the connection accessories are as follows: 6 pc screw M10 x 30, 12 pc washer a 10,5, 6 pc nut M10).
- We unscrew the blind flange from the left side of the basement and screw it to the right-hand side (the connection accessories are as follows: 4 pc screw M10 x 30, 8 pc washer 10,5, 4 pc nut M10). The blind flange with basement must be sealed with mastic.
- We apply mastic to the burner with mixer flange and we put the burner into the basement from the left-hand side and screw it (the connection accessories are as follows: 6 pc screw M10 x 30, 12 pc washer 10,5, 6 pc nut M10).
- We remove the old mastic from the grate. We apply a reasonable quantity of new mastic to the bearing surfaces and we mount the grate in the burner. (*Note: In front view to boiler the grate trimming must always be to the rear wall*)

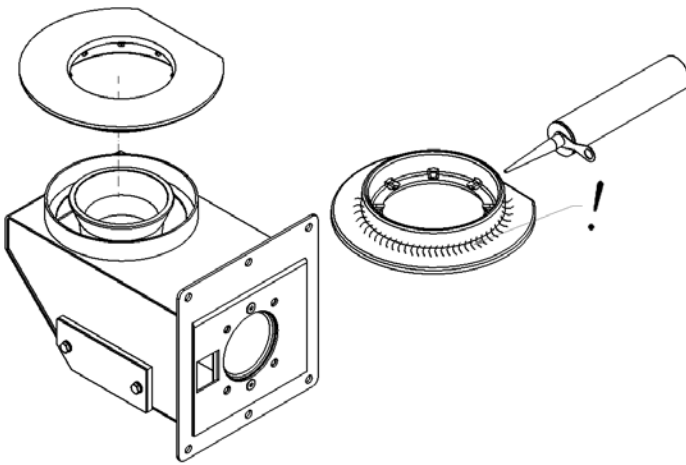

!

Apply boiler mastic to the point marked with caterpillar and put the grate on the retort with mixer. It is necessary to ensure the tightness between the burner and grate.

- Then we proceed according to chap. 5.2 Installation procedure.

Conversion of already installed boiler:

- We let the boiler burn out.
- We disconnect the boiler from mains
- We disconnect the geared motor, ventilator (we disconnect the connector), boiler primary pump, safety thermostat from regulator and we pull out the sensor against fire penetration from the basin and outlet sensor from the boiler basin, we disconnect the outside sensor and QAA 88 device. Depending on the used pump or mixing heating circuit we disconnect the HW sensor with three-way valve or thermostat with HW pump, HC pump with mixing valve and heating circuit sensor.
- We remove the service board including the consoles for service board gripping.
- We disconnect the emergency fire extinguishing equipment.
- First of all we empty the reservoir. We dismantle the fuel reservoir from the fuel feeder (the connection accessories are as follows: 4 pc screw M8 x 20, 4 pc washer 8,4 a 4 pc nut M8).
- We disconnect the fuel feeder from the boiler basement (the connection accessories are as follows: 4 pc screw M10 x 20, 4 pc washer 10,5).
- We remove the boiler shell.
- We remove the grate and pull out the burner with mixer from the basement (the connection accessories are as follows: 6 pc screw M10 x 30, 12 pc washer 10,5, 6 pc nut M10).
- We unscrew the blind flange from the basement left-hand side and screw it to the right-hand side (the connection accessories are as follows: 4 pc screw M10 x 30, 8 pc washer 10,5, 4 pc nut M10). The blind flange with basement connection must be sealed with mastic.

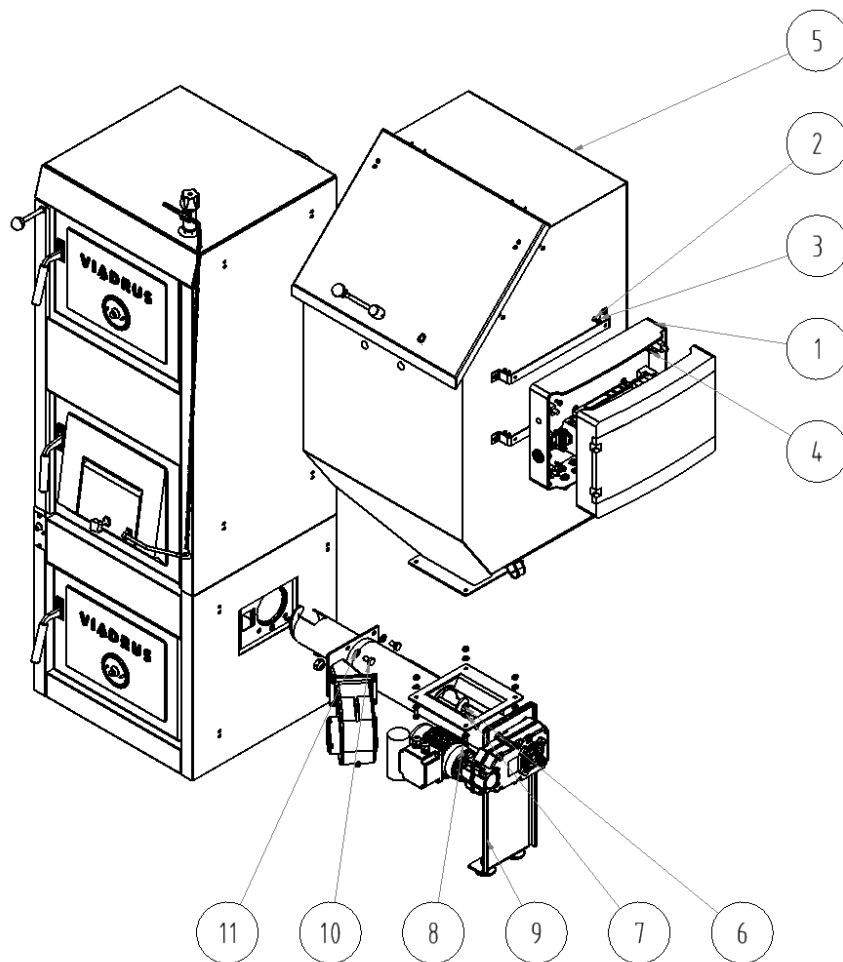

- 1 – Service board
- 2 – Nut M6 (4 pc)
- 3 – Washer 6,4 (4 pc)
- 4 – Screw M6 x 16 (4 pc)
- 5 – Fuel reservoir
- 6 – Nut M8 (4 pc)
- 7 – Washer 8,4 (8 pc)
- 8 – Screw M8 x 20 (4 pc)
- 9 – Fuel feeder
- 10 – Screw M10 x 20 (4 pc)
- 11 – Washer 10,5 (4 pc)

Fig. no. 16 Boiler conversion from the right-hand to left-hand design- fuel reservoir and feeder disconnection

- 1 – Basement
- 2 – Burner
- 3 – Grate
- 4 – Screw M10 x 30 (6 pc)
- 5 – Washer 10,5 (16 pc)
- 6 – Nut M10 (10 pc)
- 7 – Blind flange

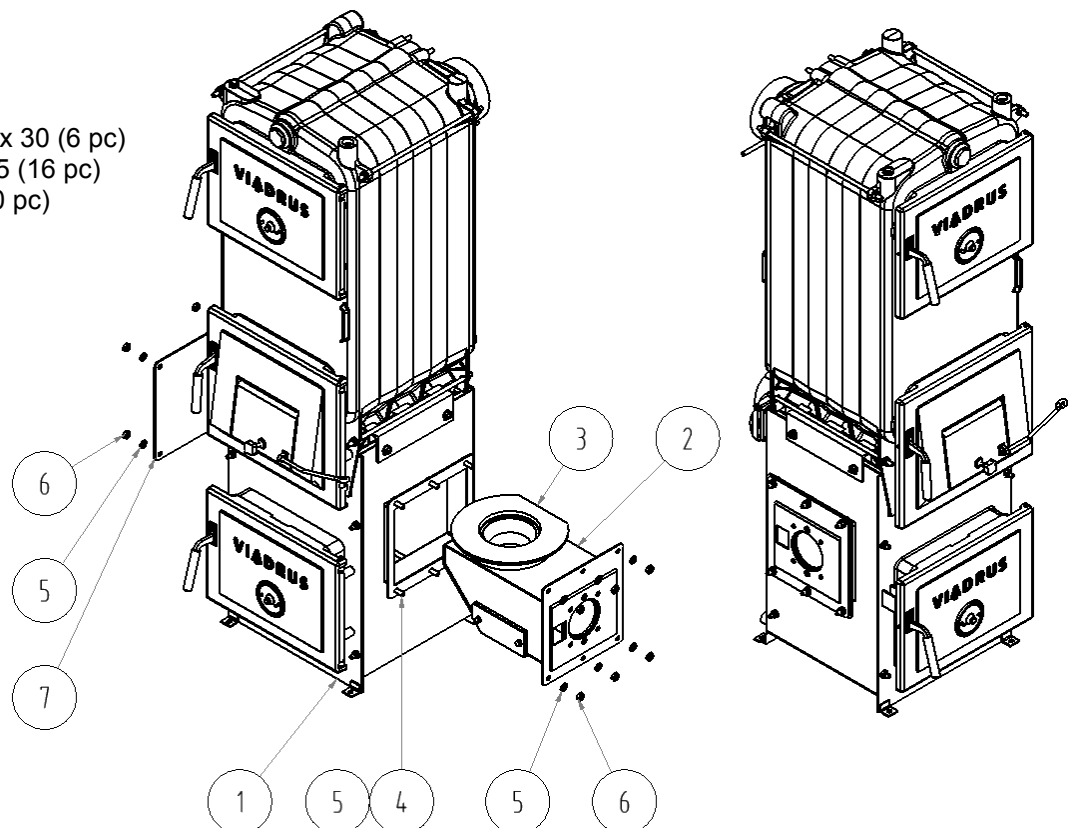
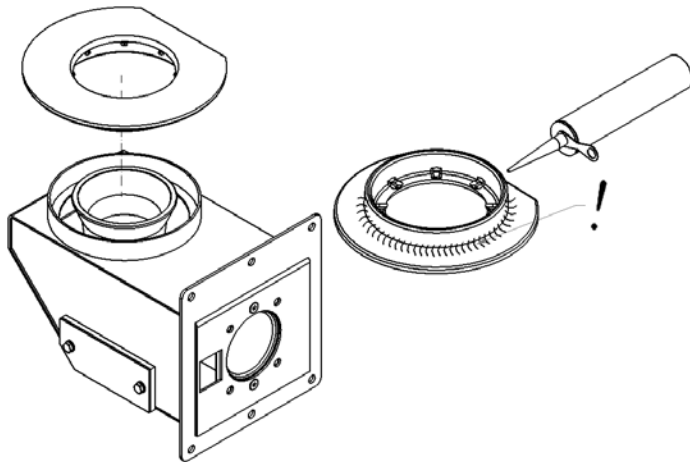

Fig. no. 17 Boiler conversion from the right-hand to left-hand design – dismantling of burner and blind flange

- We apply mastic to the burner with mixer flange and we put the burner into the basement from the left-hand side and screw it (the connection accessories are as follows: 6 pc screw M10 x 30, 12 pc washer 10,5, 6 pc nut M10).
- We remove the old mastic from the grate. We apply a reasonable quantity of new mastic to the bearing surfaces and we mount the grate in the burner. (*Note: In front view to boiler the grate trimming must always be to the rear wall*).



Apply boiler mastic to the point marked with caterpillar and put the grate on the retort with mixer. It is necessary to ensure the tightness between the burner and grate.

- We jacket the boiler (see chap. 5.2, paragraph Shells assembly).
- We apply mastic to the fuel feeder flange and connect it to the boiler basement (the connection accessories are as follows: 4 pc screw M10 x 20, 4 pc washer 10,5). We turn the motor in such a way that it is in the rear when viewing the boiler from the front.
- We apply mastic to the fuel feeder flange and we connect the feeder with the fuel reservoir (the connection accessories are as follows: 4 pc screw M8 x 20, 4 pc washer 8,4 and 4 pc nut M8).
- We connect the emergency fire-extinguishing equipment.
- We connect the service board incl. consoles to the fuel reservoir.
- We reconnect the components (in case the conversion was done already after the primary installation the length of cables must be trimmed as need may be).

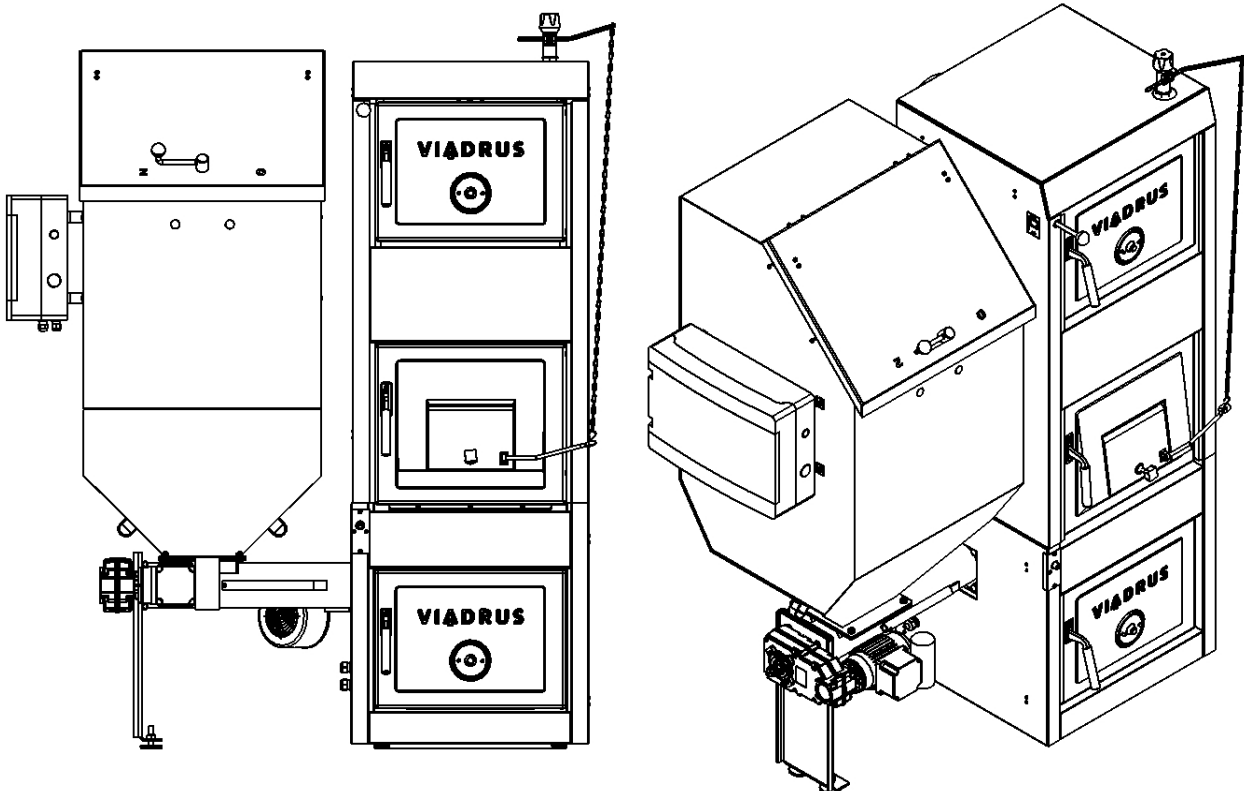
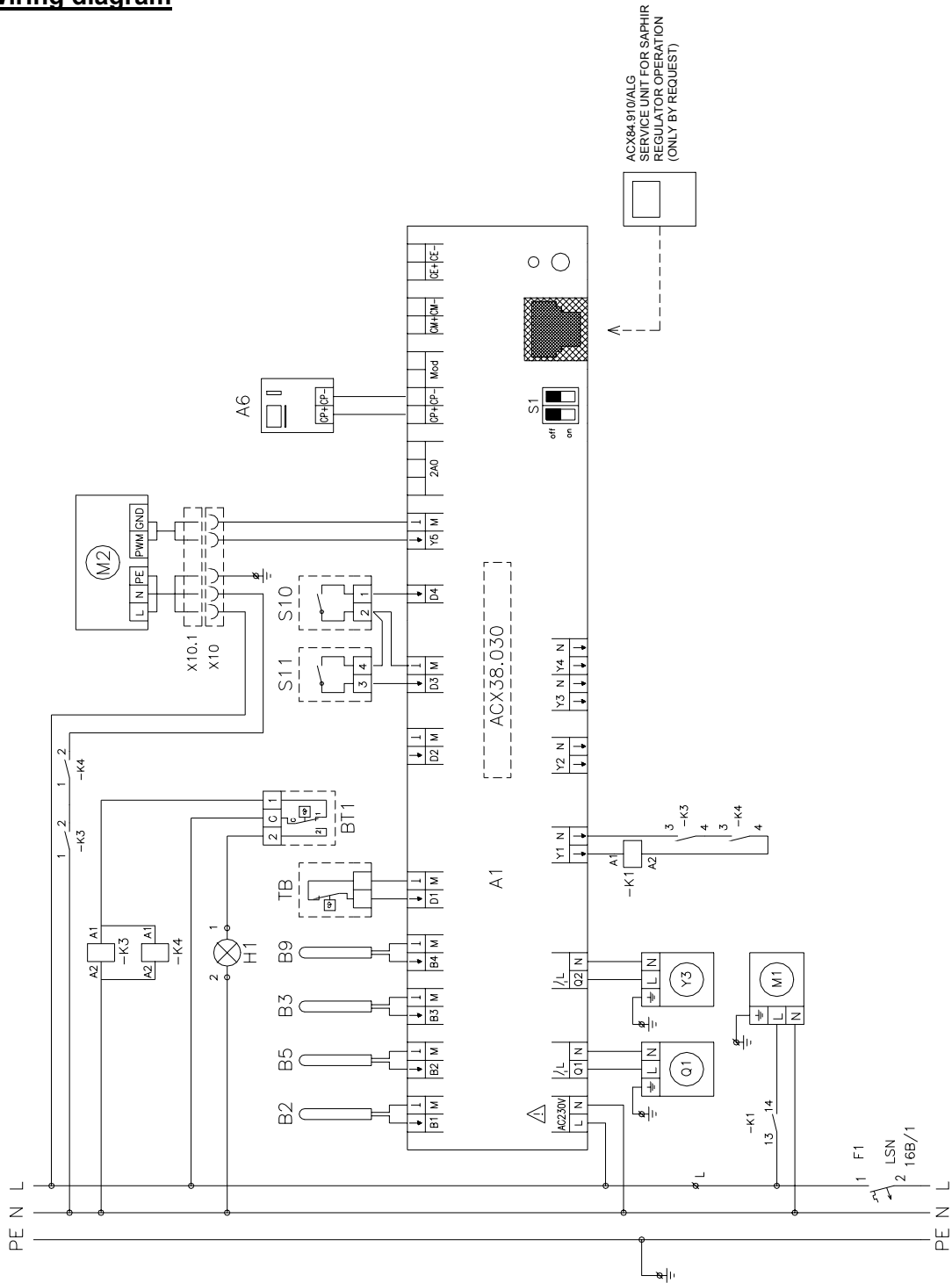

Fig. no. 18 VIADRUS HERCULES DUO boiler (left-hand design)

5.2.4 Wiring diagram



F1	Single-phase circuit breaker 16A	K3, K4	Technological relays
A1	Regulator Siemens ACX 38.030	M1	Fuel feeder motor
B2	Boiler output temperature sensor QAZ 36.526/109	M2	Air fan motor
B3	Temperature sensor HW QAZ 36.526/109	X10	Ventilator socket
A6	QAA 88 device	X10.1	Ventilator plug
B5	Fuel feeder temperature sensor QAZ 36.526/109	Q1	Boiler primary circuit pump
B9	Outside temperature sensor QAC 34/101	Y3	HW three-way valve
TB	Motor thermal protection	S1	Regulator system reverser
BT1	Safety thermostat	S10	Manual fuel move key
H1	Safety thermostat signalling	S11	Fan manual start key
K1	Fuel feeder motor relay		

Fig. no. 19 Elementary wiring diagram– Pump heating circuit

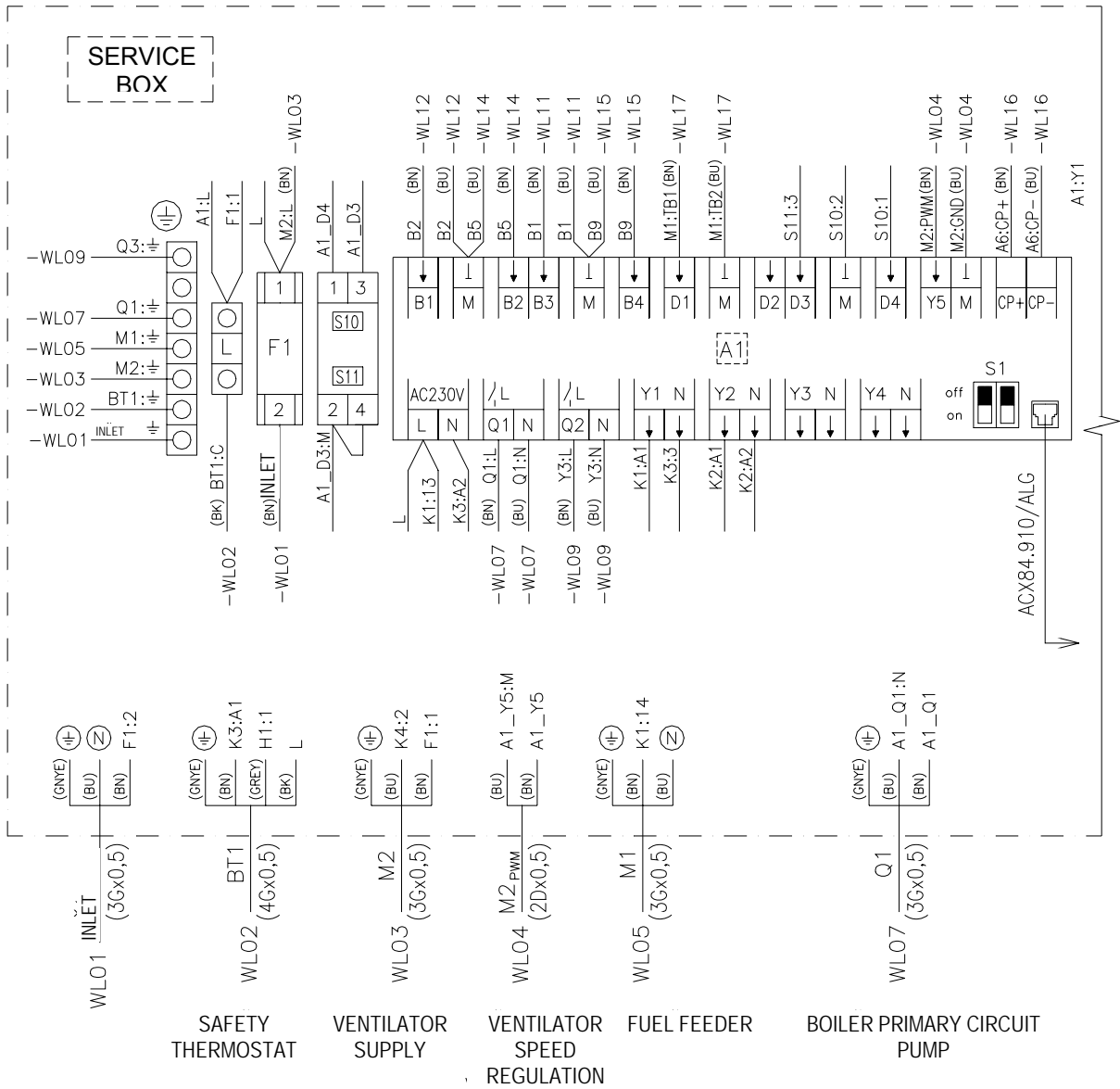

Color of conduit:
 BK Black
 BN Brown
 BU Blue
 GNYE Green-yellow
 GREY Grey
 WHITE White
 YELLOW Yellow
 RED Red

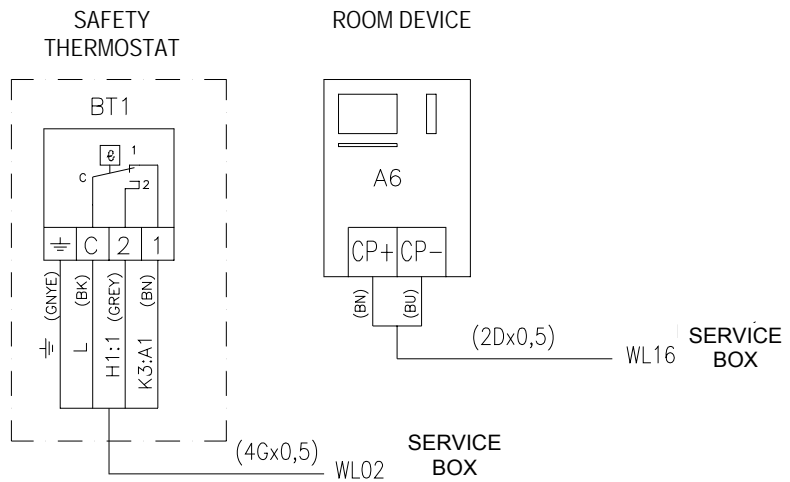
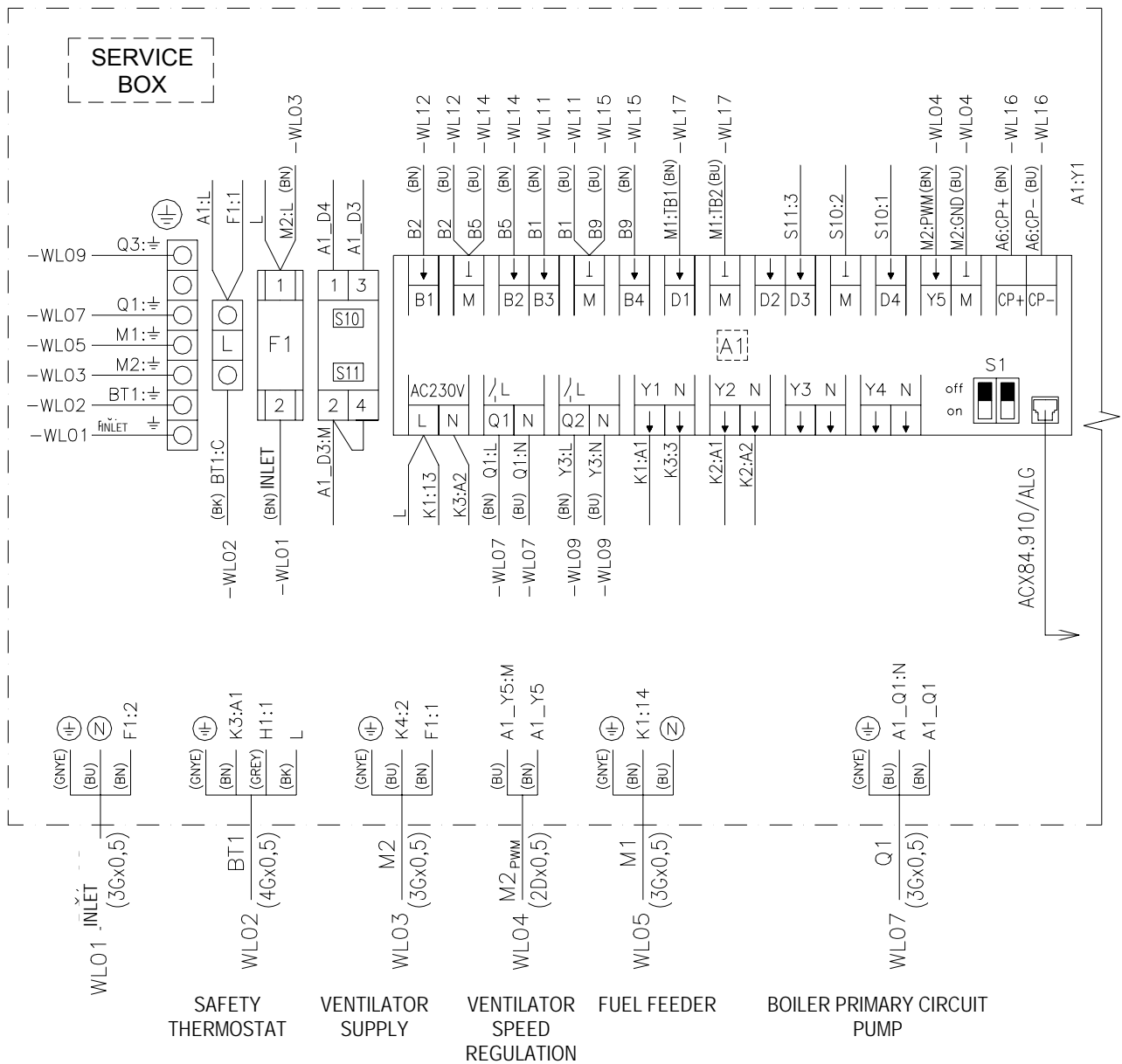

Fig. no. 20a) Connection diagram– Pump heating circuit



- Color of conduit:
- BK Black
 - BN Brown
 - BU Blue
 - GNYE Green-yellow
 - GREY Grey
 - WHITE White
 - YELLOW Yellow
 - RFD Red

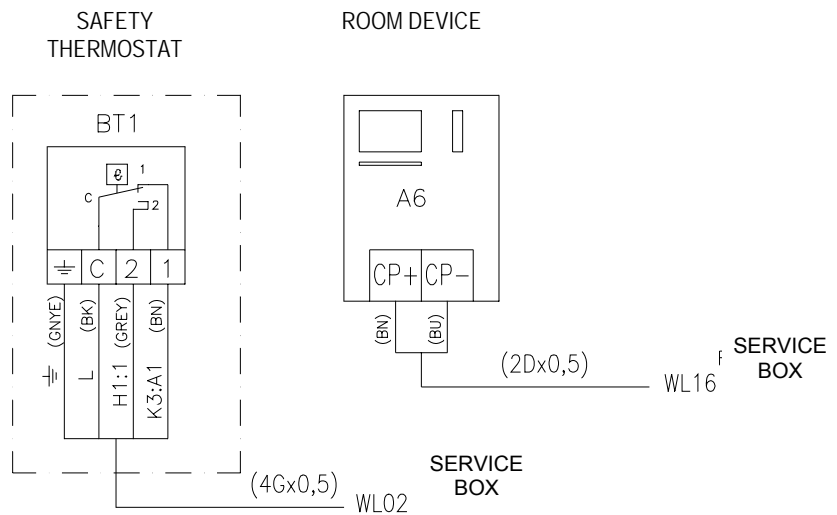
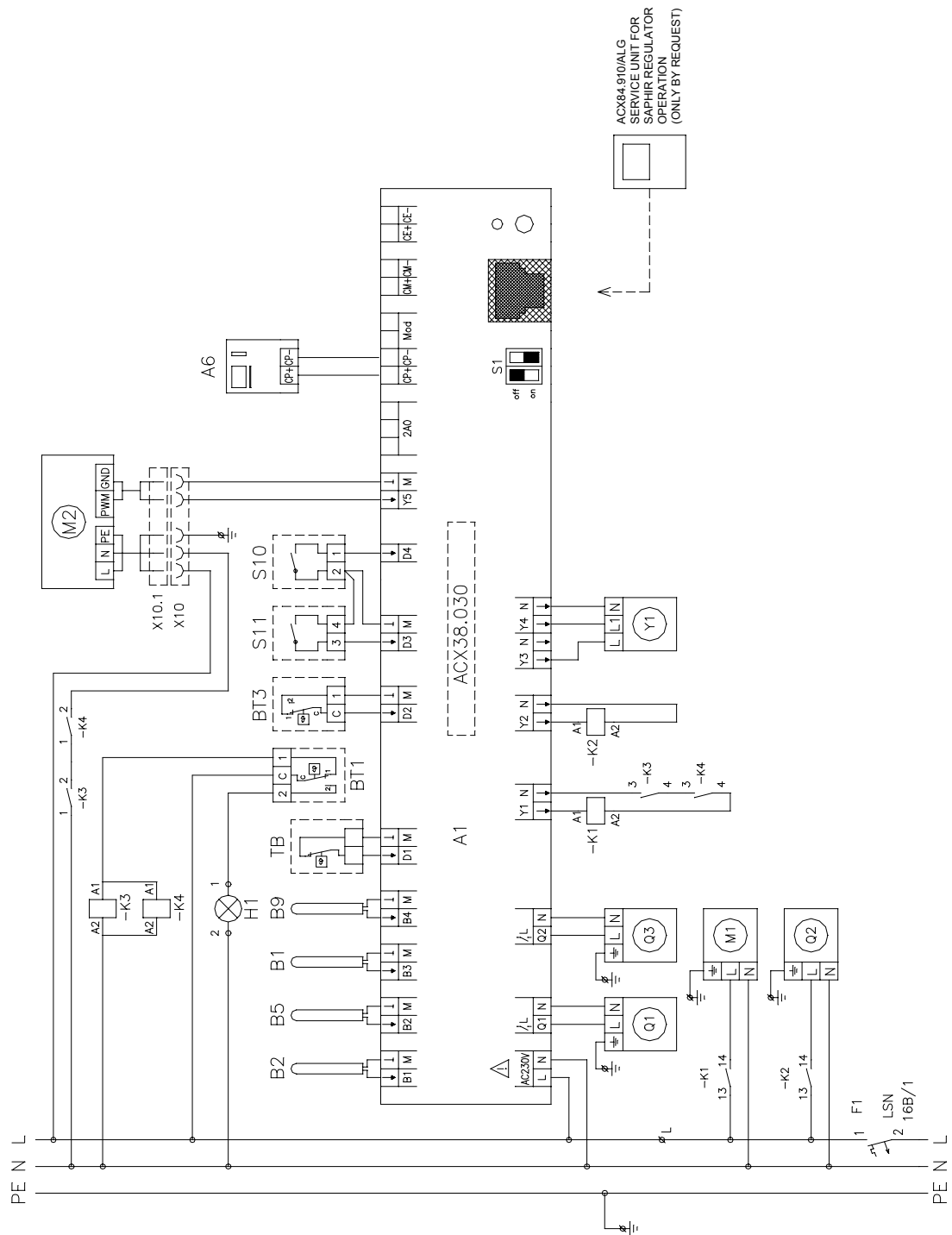

Fig. no. 20b) Connection diagram – Pump heating circuit



- | | | | |
|-----|--|--------|--|
| F1 | Single-phase circuit breaker 16A | K3, K4 | Technological relays |
| A1 | Regulator Siemens ACX 38.030 | M1 | Fuel feeder motor |
| B1 | Heating branch temperature sensor QAZ 36.526/109 | M2 | Air fan motor |
| B2 | Boiler output temperature sensor QAZ 36.526/109 | X10 | Air fan motor socket |
| A6 | QAA88 device | X10.1 | Ventilator plug |
| B5 | Fuel feeder temperature sensor QAZ 36.526/109 | Q1 | Boiler primary circuit pump |
| B9 | Outside temperature sensor QAC 34/101 | Q2 | Heating circuit pump |
| TB | Motor thermal protection | Q3 | HW charging pump |
| BT1 | Safety thermostat | S1 | Regulator system reverser |
| BT3 | HW thermostat | S10 | Manual fuel move key |
| H1 | Safety thermostat signalling | S11 | Ventilator manual start key |
| K1 | Fuel feeder motor relay | Y1 | Drive of heating circuit three-way valve |
| K2 | Heating branch pump relay | | |

Fig. no. 21 Elementary wiring diagram – Mixing heating circuit

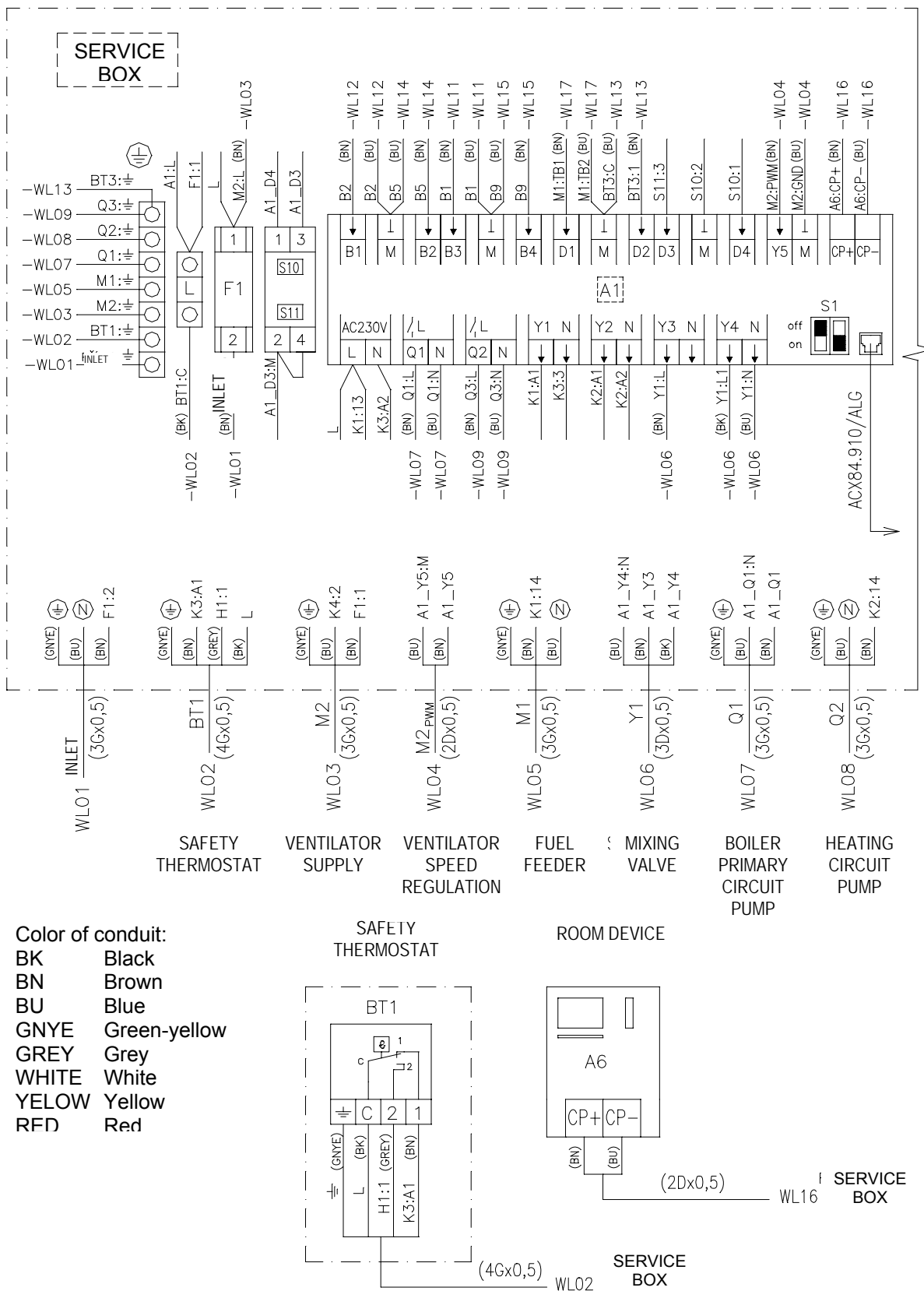

Fig. no. 22a) Connection diagram – Mixing heating circuit

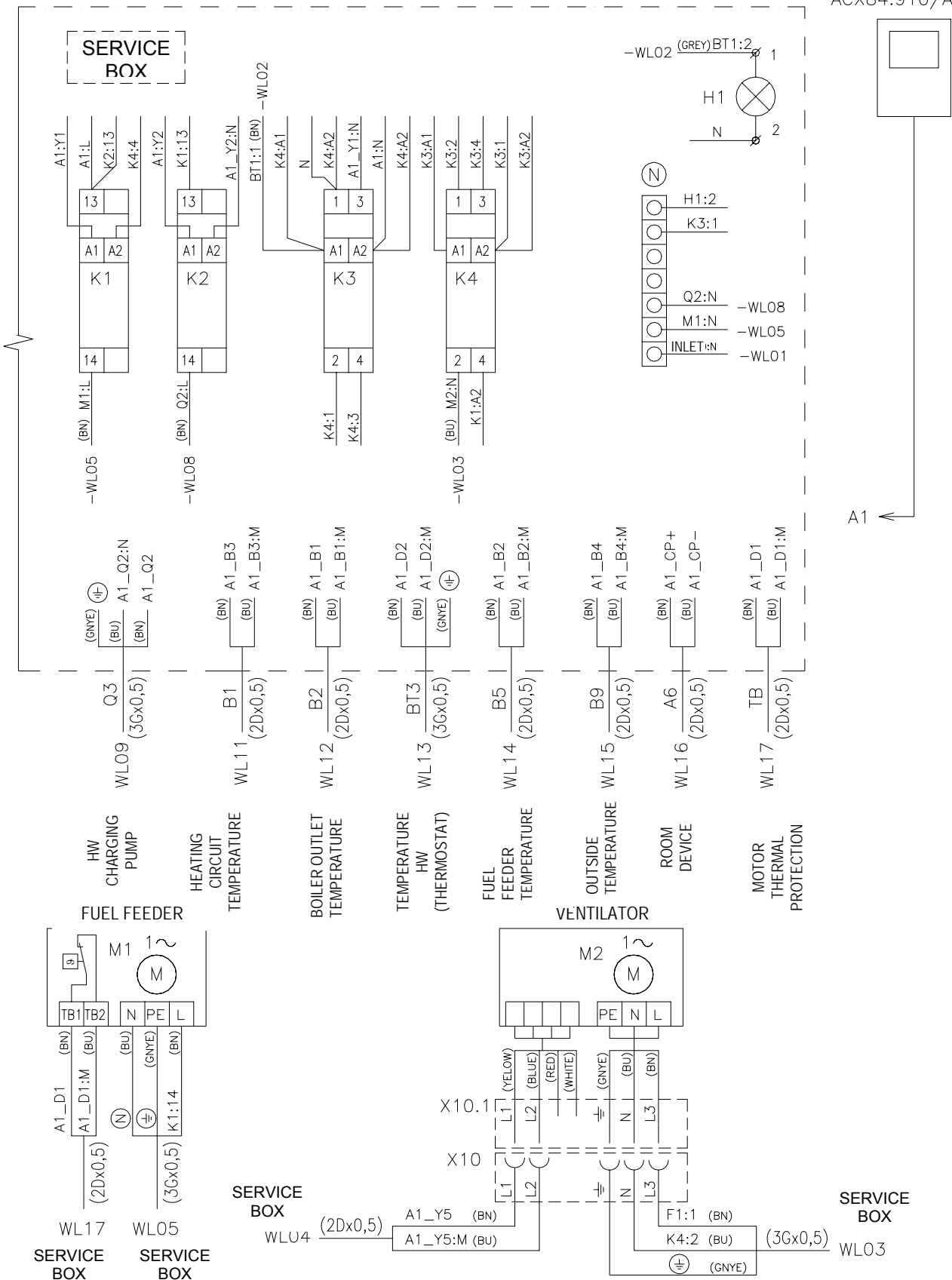

Fig. no. 22b) Connection diagram – Mixing heating circuit

6. Automatic operation

6.1 Control, regulation and security elements

6.1.1 Saphir regulator

SAPHIR ACX 38 is the regulator destined for solid fuel boiler control, heating circuit control and hot water preparation by means of external reservoir control. The regulator is equipped with boiler sensor, hot water sensor or hot water thermostat (depending on the pump or mixing heating circuit), heating branch sensor (mixing heating circuit), sensor against the fire penetration and outside sensor. The regulator co-operates with **QAA 88 device** that can be used as space device or boiler display.

The regulator is equipped with two software regimes (pump or mixing heating circuit) that can be switched over by means of system reverser of S1 regulator. The regulator system reverser is installed in the regulator in its right-hand lower part.

A. Pump heating circuit

The right-hand segment of S1 switch is in position **off**.

- **heating circuit (HC)** – at the pump heating circuit there is not used the three-way mixing valve SQK 34. If the outside sensor is installed the boiler operation is controlled equithermally. The heating water temperature varies in the range of setting from the min. boiler temperature to the max heating circuit temperature. If the outside sensor is not installed (it must be deactivated) the boiler operation is controlled by the space device. In case of outside sensor fault the boiler heats to the fixed temperature (set by manufacturer to 70 °C).
- **warm water (HW)** – HW preparation is solved by means of HW sensor, three-way valve and HW external reservoir. In case of HW preparation the boiler temperature is increased (set by manufacturer to 15 °C) against the desired warm water temperature.
- **boiler**
 - a) **automatic regime** – the boiler is controlled by the heat requirement (heating branch, warm water and min. boiler temperature). The boiler output is given by the current heat requirement modulated in the sphere of output range. The ventilator output is controlled by the change in revolutions and the fuel quantity is allocated adequately to the air volume. The boiler temperature increase against the heating branch desired temperature is 5°C (set by the manufacturer).
 - b) **attenuation regime** – after the requirement for heat has ceased the boiler goes over to the attenuation regime. The minimum boiler temperature is kept in the attenuation regime.
- **Boiler pump** – the pump is switched on when 55°C has been reached (set by the manufacturer). The pump is switched off when the temperature has dropped by 5°C against the setting by the manufacturer. In the attenuation regime the pump is switched on at the temperature 70 °C and switched off when the temperature has dropped by 5°C.
- **boiler antifreeze protection**- it depends on the actual water temperature in the boiler. In case the water temperature in the boiler has dropped below 5°C the boiler pump will switch on.

B. Mixing heating circuit

The right-hand segment of S1 switch is in position **on**.

- **heating circuit (HC)** – at the mixing heating circuit there is used the three-way mixing valve SQK 34. If the outside sensor is installed the boiler is controlled equithermally. The heating water temperature varies in the range of setting from the min. heating circuit temperature to the maximum set heating circuit temperature. The three-way mixing valve is mixing the heating water to the desired temperature. If the outside sensor is not installed (it must be deactivated) the boiler operation is controlled by the space device. In case of outside sensor fault the boiler heats to the fixed temperature (set by manufacturer to 70 °C).
- **warm water (HW)** – HW preparation is solved by means of HW thermostat, charging pump and HW external reservoir. In case of HW preparation the boiler temperature is increased (set by manufacturer to 15 °C) against the desired warm water temperature. The temperature set on the reservoir thermostat must correspond to the set desired temperature in the table of parameters. HW pump is switched on by the requirement for warm water. After the requirement for warm water has ceased the pump is in slowing-down regime. If the boiler temperature drops at least by 3°C against the desired HW temperature plus the increase (set by manufacturer to 15 °C) HW pump will not operate. If this limitation is active then HC pump will not operate either.
- **boiler**
 - a) **automatic regime** – boiler is controlled by the heat requirement (heating branch, warm water and minimum boiler temperature). The boiler output is given by the actual heat requirement modulated in the sphere of output range. The ventilator output is controlled by the change in

revolutions and the fuel quantity is allocated adequately to the air volume. The boiler temperature increase against the heating branch desired temperature is 5 °C (set by the manufacturer).

b) attenuation regime – after the requirement for heat has ceased the boiler goes over to the attenuation regime. The minimum boiler temperature is kept in the attenuation regime.

- **Boiler pump** – the pump is switched on when 55 °C has been reached (set by the manufacturer). The pump is switched off when the temperature has dropped by 5 °C against the setting by the manufacturer. In the attenuation regime the pump is switched on at the temperature 70 °C and switched off when the temperature has dropped by 5 °C.
- **heating branch pump** – is switched on together with the requirement for heat. After the requirement for warm water has ceased the pump will be in slowing-down regime
- **boiler antifreeze protection**- it depends on the actual water temperature in the boiler. In case the water temperature in the boiler has dropped below 5°C the boiler pump will switch on.

In order to save the regulator safety functions the boiler shouldn't be disconnected from mains.

In case of boiler disconnection from mains time in regulator might stop and consequently the time regimes will switch incorrectly. Then the boiler minimum temperature is not kept and in an extreme case (boiler near an open window in winter season, boiler fault) boiler and heating circuit could freeze up. At the switched off boiler (but not disconnected from mains) the antifreeze protection is active by means of pumps.

In an extreme case also the fuel fire penetration into reservoir (pellets used the fuel) can occur. At the switched off boiler (but not disconnected from mains) the protection against fuel fire penetration into reservoir is active. In case of a long-term electricity outage pellets should be removed from the burner in order to prevent their fire penetration to the reservoir. In this way we prevent the burning fuel from being poured with water (which is the function of emergency fire extinguishing system – see chap. 5.2) and we are spared of complicated removal of soaked pellets from the fuel feeder

Boiler (cursor is above symbol ), heating circuit (parameter P 40) or HW preparation (parameter P 42) can be switched of by means of QAA 88 device

Pump heating circuit – configuration

<i>Boiler equipment</i>	<i>Type of operation</i>
<i>Necessary boiler accessories</i>	

Note: The equithermal control at the pump heating circuit is possible in the range from minimum set boiler temperature to maximum set heating circuit temperature.

<ul style="list-style-type: none"> • QAA 88 device – space unit • Outside sensor QAC34/101 • Thermostatic valve (Filling valve) - series VTC312 (external thread) from ESBE (minimum return water temperature 45 °C) (ord. code: 5100 15 00) 	Equithermal control with space effect
<ul style="list-style-type: none"> • Three-way valve V4044C (only in case boiler is used for HW heating) • Warm water sensor QAZ36 (only in case boiler is used for HW heating) 	
<ul style="list-style-type: none"> • QAA 88 device – boiler unit • Outside sensor QAC34/101 • Thermostatic valve (Filling valve) - series VTC312 (external thread) from ESBE (minimum return water temperature 45 °C) (ord. code: 5100 15 00) 	Equithermal control without space effect
<ul style="list-style-type: none"> • Three-way valve V4044C (only in case boiler is used for HW heating) • Warm water sensor QAZ36 (only in case boiler is used for HW heating) 	

<ul style="list-style-type: none"> • QAA 88 device – space unit • Outside sensor QAC34/101 – is not used • Thermostatic valve (Filling valve) - series VTC312 (external thread) from ESBE (minimum return water temperature 45 °C) (ord. code: 5100 15 00) 	Space control
<ul style="list-style-type: none"> • Three-way valve V4044C (only in case boiler is used for HW heating) • Warm water sensor QAZ36 (only in case boiler is used for HW heating) 	
<ul style="list-style-type: none"> • QAA 88 device – space unit • HMI Service unit for Saphir regulator operation (ACX84.910/ALG) – only by request • Outside sensor QAC34/101 • Thermostatic valve (Filling valve) - series VTC312 (external thread) from ESBE (minimum return water temperature 45 °C) (ord. code: 5100 15 00) 	Equithermal control with space effect
<ul style="list-style-type: none"> • Three-way valve V4044C (only in case boiler is used for HW heating.) • Warm water sensor QAZ36 (only in case boiler is used for HW heating) 	
<ul style="list-style-type: none"> • QAA 88 device – space unit • HMI service unit for Saphir regulator operation (ACX84.910/ALG) – only by request • Outside sensor QAC34/101 – is not used • Thermostatic valve (Filling valve) - series VTC312 (external thread) from ESBE (minimum return water temperature 45 °C) (ord. code: 5100 15 00) 	Space control
<ul style="list-style-type: none"> • Three-way valve V4044C (only in case boiler is used for HW heating.) • Warm water sensor QAZ36 (only in case boiler is used for HW heating) 	
<ul style="list-style-type: none"> • HMI service unit for Saphir regulator operation (ACX84.910/ALG) – only by request • Outside sensor QAC34/101 • Thermostatic valve (Filling valve) - series VTC312 (external thread) from ESBE (minimum return water temperature 45 °C) (ord. code: 5100 15 00) 	Equithermal control without space effect
<ul style="list-style-type: none"> • Three-way valve V4044C (only in case boiler is used for HW heating) • Warm water sensor QAZ36 (only in case boiler is used for HW heating) 	

Mixing heating circuit – configuration

<i>Boiler equipment</i>	<i>Type of operation</i>
<i>Necessary boiler accessories</i>	
<ul style="list-style-type: none"> • QAA 88 device – space unit • Outside sensor QAC34/101 • Thermostatic valve (Filling valve) - series VTC312 (external thread) from ESBE (minimum return water temperature 45 °C) (ord. code: 5100 15 00) 	Equithermal control with space effect
<ul style="list-style-type: none"> • Three-way mixing valve VBI31.20 with drive SQK34.00 • Heating branch sensor QAD36/101 • Water heater thermostat type: 7K1.6R326.00A (only in case boiler is used for HW heating.) 	

<ul style="list-style-type: none"> • QAA 88 device – boiler unit • Outside sensor QAC34/101 • Thermostatic valve (Filling valve) - series VTC312 (external thread) from ESBE (minimum return water temperature 45 °C) (ord. code: 5100 15 00) 	<p>Equithermal control without space effect</p>
<ul style="list-style-type: none"> • Three-way mixing valve VBI31.20 with drive SQK34.00 • Heating branch sensor QAD36/101 • Water heater thermostat type: 7K1.6R326.00A (only in case boiler is used for HW heating) 	
<ul style="list-style-type: none"> • QAA 88 device – space unit • Outside sensor QAC34/101 – is not used • Thermostatic valve (Filling valve) - series VTC312 (external thread) from ESBE (minimum return water temperature 45 °C) (ord. code: 5100 15 00) 	<p>Space control</p>
<ul style="list-style-type: none"> • Three-way mixing valve VBI31.20 with drive SQK34.00 • Heating branch sensor QAD36/101 • Water heater thermostat type: 7K1.6R326.00A (only in case boiler is used for HW heating.) 	
<ul style="list-style-type: none"> • QAA 88 device – space unit • HMI service unit for Saphir regulator operation (ACX84.910/ALG) – only by request • Outside sensor QAC34/101 • Thermostatic valve (Filling valve) - series VTC312 (external thread) from ESBE (minimum return water temperature 45 °C) (ord. code: 5100 15 00) 	<p>Equithermal control with space effect</p>
<ul style="list-style-type: none"> • Three-way mixing valve VBI31.20 with drive SQK34.00 • Heating branch sensor QAD36/101 • Water heater thermostat type: 7K1.6R326.00A (only in case boiler is used for HW heating) 	
<ul style="list-style-type: none"> • QAA 88 device – space unit • HMI Service unit for Saphir regulator operation (ACX84.910/ALG) – only by request • Outside sensor QAC34/101 – is not used • Thermostatic valve (Filling valve) - series VTC312 (external thread) from ESBE (minimum return water temperature 45 °C) (ord. code: 5100 15 00) 	<p>Space control</p>
<ul style="list-style-type: none"> • Three-way mixing valve VBI31.20 with drive SQK34.00 • Heating branch sensor QAD36/101 • Water heater thermostat type: 7K1.6R326.00A (only in case boiler is used for HW heating) 	
<ul style="list-style-type: none"> • HMI Service unit for Saphir regulator operation (ACX84.910/ALG) – only by request • Outside sensor QAC34/101 • Thermostatic valve (Filling valve) - series VTC312 (external thread) from ESBE (minimum return water temperature 45 °C) (ord. code: 5100 15 00) 	<p>Equithermal control without space effect</p>
<ul style="list-style-type: none"> • Three-way mixing valve VBI31.20 with drive SQK34.00 • Heating branch sensor QAD36/101 • Water heater thermostat type: 7K1.6R326.00A (only in case boiler is used for HW heating) 	

Note:

In case the equithermal control is without space effect we must suitably set P 21 parameter. If there is not reached the desired P 103 (P 106 and P 109) space temperature we must increase the slope of heating curve. Correct setting of heating curve slope is done by the end user. The changes do not become evident immediately, but with regard to the equipment adaptability and various buildings inertia they become evident after some time which might make several days.

The heating curve can be tuned by the parallel shift (parameter P 19). By increasing the value we increase the desired heating circuit temperature thus we increase the temperature in the space. The parallel shift parameter shifts the whole heating curve. The heating curve slope parameter only changes the slope of the curve.

6.1.2 Safety thermostat

The safety thermostat is mounted on the left-hand side part of basement shell and it serves for boiler shutdown in case the safety temperature has been exceeded. The safety thermostat must be set to 100 °C temperature i.e. to the temperature higher than the set maximum boiler temperature (90 °C). After the safety thermostat switch-off the safety thermostat signal lamp will light up. The fuel feeder and ventilator will stop. The safety thermostat de-blocking must be done manually – after the cover dismantling and then pressing the trap.

In case of safety thermostat repeated switch-offs it is necessary to put the boiler out of service and find the reason of boiler repeated overheating. After the safety thermostat switch-off the primary pump (or HC pump) is still working.

6.1.3 Temperature sensor on the fuel feeder

If the temperature set in P26 parameter appears on the temperature sensor the fuel feed will be accelerated in order to move the burning fuel to the burner. Once the temperature has dropped below the set value the boiler will come back into the original regime. This security only functions in case the boiler is supplied with electricity. If the feeder temperature hasn't dropped within 7 minutes (preset value) the feeder will be shut down.

6.1.4 Emergency fire-extinguishing system

In case of fuel fire penetration into the feeder (95 °C temperature reached on the feeder) the BVTs (TS 130, STS 20) valve opens the water inlet into the hopper in order to extinguish the burning fuel; once the temperature on sensor has dropped by 6°C the water inlet will be closed.

6.1.5 Forced withdrawal of superfluous heat

6.1.5.1 Forced withdrawal of superfluous boiler heat

In case the boiler temperature has exceeded 90°C so called forced withdrawal of the superfluous heat into the heating circuit will start. The fan and feeder are not active. In case the temperature is lower than the current desired boiler temperature the boiler comes back into actual automatic regime (in case the boiler temperature has reached 100°C and the safety thermostat has been blocked the thermostat must be manually de-blocked).

Mixing heating circuit

Forced withdrawal of the superfluous heat is activated in case the outlet boiler temperature 90 °C has been exceeded. The outlet boiler temperature by means of three-way mixing valve will be reduced to the maximum heating circuit temperature (80 °C – parameter P 77).

6.1.5.2 Forced withdrawal of superfluous water heater heat

If the temperature in water heater has exceeded 80 °C the forced withdrawal of the superfluous heat into the heating circuit will start (only in case of pump heating circuit).

6.2 SAPHIR regulator parameters

In the next tables there are listed parameters that can be changed by means of QAA 88 device. The way of displaying and changing the parameters is described in chap. 6.3.1.

Note:

HW – warm water

HC – heating circuit

Tab. no. 7 Parameters – Mixing heating circuit

Parameter	Description	Units	Set by the manufacturer	Range	Resolution
P 1	Current outside temperature	[°C]	-	-20 ... 50	0,1
P 2	Current boiler temperature	[°C]	-	5 ... 100	0,1
P 3	Current heating circuit temperature	[°C]	-	5 ... 100	0,1
P 4	Desired heating circuit temperature	[°C]	-	0 ... 80	0,1
P 6	Desired boiler temperature in case of HW heating	[°C]	-	0 ... 75	1
P 7	Current warm water thermostat status		-	0 ... 1	1
P 8	Current feeder temperature	[°C]	-	5 ... 100	0,1
P 9	Current space temperature	[°C]	-	0 ... 40	0,1
P 10	Current position of three-way mixing valve	[%]	-	0 ... 100	0,1
P 11	Desired boiler temperature	[°C]	-	20 ... 85	0,1
P 12	Current ventilator output	[%]	-	0 ... 100	0,1
P 15	Faults		-	0 ... 15	
P 19	Parallel shift in the heating curve	[°C]	0	-10 ... 10	1
P 20	Fuel type		1	1 ... 4	1
P 21	Slope of heating curve		1,5	0,1 ... 4	0,1
P 22	Ventilator output when making fire	[%]	50	1 ... 100	1
P 23	Minimum boiler temperature	[°C]	30	20 ... 70	0,1
P 24	Type of requirement (auto/fixe)		0	0 ... 1	1
P 25	Boiler hysteresis	[°]	3	1 ... 5	0,1
P 26	Maximum feeder temperature	[°C]	90	85 ... 95	1
P 27	Boiler heating deficiency	[min.]	30	10 ... 60	1
P 28	QAA position		2	1 ... 2	1
P 40	Heating circuit off/on		1	0 ... 1	1
P 41	Boiler temperature increase from the heating circuit	[°C]	5	0 ... 20	1
P 42	Warm water off/on		1	0 ... 1	1
P 43	Boiler temperature increase from HW	[°C]	15	5 ... 20	1
P 50	Boiler primary pump man/auto		1	0 ... 1	1
P 51	Boiler primary pump off/on		-	0 ... 1	1
P 52	Boiler primary pump slowing-down	[min.]	5	0 ... 60	1
P 53	Boiler primary pump switch-on temperature	[°C]	55	20 ... 60	1
P 54	Day of boiler primary pump spinning		5	0 ... 8	1
P 55	Heating circuit pump man/auto		1	0 ... 1	1
P 56	Heating circuit pump off/on		-	0 ... 1	1
P 57	Heating circuit pump slowing-down	[min.]	3	0 ... 60	1
P 58	Day of heating circuit pump spinning		5	0 ... 8	1
P 59	Warm water pump man/auto		1	0 ... 1	1
P 60	Warm water pump off/on		-	0 ... 1	1
P 61	Warm water pump slowing-down	[min.]	3	0 ... 10	1
P 62	Day of warm water pump spinning		5	0 ... 8	1
P 70	Outside temperature reset		0	0 ... 1	1
P 71	Space hysteresis	[°C]	0,5	0 ... 5	0,1
P 72	Space effect	[%]	20	0 ... 100	1
P 76	Minimum heating circuit temperature	[°C]	30	20 ... 50	1
P 77	Maximum heating circuit temperature	[°C]	83	30 ... 90	1
P 80	Building constant	[h]	10	1 ... 50	1
P 81	Temperature ECO	[°C]	-3	-5 ... 5	1
P 82	ECO automatics passive/active		-	0 ... 1	1
P 83	Temperature summer/winter	[°C]	17	8 ... 35	1
P 84	Constant summer/winter	[h]	50	1 ... 100	1
P 85	Current status summer/winter		-	0 ... 1	1
P 86	Heating system		3	0 ... 3	1
P 87	HC antifreeze protection off/on		1	0 ... 1	1
P 88	Servo overruntime	[s]	120	10 ... 1800	1
P 100	Setting the day of time schedule for HC		0	0 ... 7	1
P 101	First HC period switched on	[h:min.]	6:00	0:00 ... 23:59	1 min.

Parameter	Description	Units	Set by the manufacturer	Range	Resolution
P 102	First HC period switched off	[h:min.]	22:00	0:00 ... 23:59	1 min.
P 103	Desired space temperature in the first period	[°C]	21	10 ... 30	0,1
P 104	Second period HC switched on	[h:min.]	23:59	0:00 ... 23:59	1 min.
P 105	Second period HC switched off	[h:min.]	23:59	0:00 ... 23:59	1 min.
P 106	Desired space temperature in the second period	[°C]	21	10 ... 30	0,1
P 107	Third period HC switched on	[h:min.]	23:59	0:00 ... 23:59	1 min.
P 108	Third period HC switched off	[h:min.]	23:59	0:00 ... 23:59	1 min.
P 109	Desired space temperature in the third period	[°C]	20	10 ... 30	0,1
P 110	Time schedule reset HC		0	0 ... 1	1
P 111	Desired space temperature in attenuation	[°C]	19	5 ... 25	0,1
P 120	Setting the day of time schedule for HW		0	0 ... 7	1
P 121	First period HW switched on	[h:min.]	6:00	0:00 ... 23:59	1 min.
P 122	First period HW switched off	[h:min.]	22:00	0:00 ... 23:59	1 min.
P 123	Desired temperature HW in the first period	[°C]	60	10 ... 65	1
P 124	Second period HW switched on	[h:min.]	23:59	0:00 ... 23:59	1 min.
P 125	Second period HW switched off	[h:min.]	23:59	0:00 ... 23:59	1 min.
P 126	Desired temperature HW in the second period	[°C]	55	10 ... 65	1
P 127	Third period HW switched on	[h:min.]	23:59	0:00 ... 23:59	1 min.
P 128	Third period HW switched off	[h:min.]	23:59	0:00 ... 23:59	1 min.
P 129	Desired temperature HW in the third period	[°C]	50	10 ... 65	1
P 131	HW Time schedule reset		0	0 ... 1	1
P 140	Feeder runtime	[s]	5	5 ... 10	0,1
P 150	Feeder X1 lignite	[%]	0	0	0
P 151	Feeder Y1 lignite	[s]	65	55 ... 75	1
P 152	Feeder X2 lignite	[%]	33	33	0
P 153	Feeder Y2 lignite	[s]	38	28 ... 48	1
P 154	Feeder X3 lignite	[%]	66	66	0
P 155	Feeder Y3 lignite	[s]	26	21 ... 31	1
P 156	Feeder X4 lignite	[%]	100	100	0
P 157	Feeder Y4 lignite	[s]	20	15 ... 25	1
P 158	Feeder runtime in the attenuation – lignite	[s]	5	3 ... 10	1
P 159	Standstill time(delay) feeder in the attenuation – lignite	[min]	40	10 ... 240	1
P 160	Ventilator X1 lignite	[%]	0	0	0
P 161	Ventilator Y1 lignite	[%]	30	25 ... 35	1
P 162	Ventilator X2 lignite	[%]	33	33	0
P 163	Ventilator Y2 lignite	[%]	35	30 ... 40	1
P 164	Ventilator X3 lignite	[%]	66	66	0
P 165	Ventilator Y3 lignite	[%]	48	43 ... 58	1
P 166	Ventilator X4 lignite	[%]	100	100	0
P 167	Ventilator Y4 lignite	[%]	50	45 ... 60	1
P 168	Ventilator slowing-down in the attenuation regime– lignite	[s]	30	5 ... 120	1
P 169	Ventilator output in the attenuation – lignite	[%]	100	50 ... 100	1
P 170	Feeder X1 hard coal	[%]	0	0	0
P 171	Feeder Y1 hard coal	[s]	90	80 ... 99	1
P 172	Feeder X2 hard coal	[%]	33	33	0
P 173	Feeder Y2 hard coal	[s]	42	32 ... 52	1
P 174	Feeder X3 hard coal	[%]	66	66	0
P 175	Feeder Y3 hard coal	[s]	32	27 ... 37	1
P 176	Feeder X4 hard coal	[%]	100	100	0
P 177	Feeder Y4 hard coal	[s]	27	23 ... 33	1
P 178	Feeder runtime in the attenuation – hard coal	[s]	5	3 ... 10	1
P 179	Standstill time(delay) feeder in the attenuation – hard coal	[min.]	40	10 ... 240	1

Parameter	Description	Units	Set by the manufacturer	Range	Resolution
P 200	Ventilator X1 hard coal	[%]	0	0	0
P 201	Ventilator Y1 hard coal	[%]	28	23 ... 33	1
P 202	Ventilator X2 hard coal	[%]	33	33	0
P 203	Ventilator Y2 hard coal	[%]	34	29 ... 39	1
P 204	Ventilator X3 hard coal	[%]	66	66	0
P 205	Ventilator Y3 hard coal	[%]	70	65 ... 75	1
P 206	Ventilator X4 hard coal	[%]	100	100	0
P 207	Ventilator Y4 hard coal	[%]	75	70 ... 80	1
P 208	Ventilator slowing-down in the attenuation regime– hard coal	[s]	30	5 ... 120	1
P 209	Ventilator output in the attenuation – hard coal	[%]	100	50 ... 100	1
P 210	Feeder X1 pellets	[%]	0	0	0
P 211	Feeder Y1 pellets	[s]	60	50 ... 70	1
P 212	Feeder X2 pellets	[%]	33	33	0
P 213	Feeder Y2 pellets	[s]	29	19 ... 39	1
P 214	Feeder X3 pellets	[%]	66	66	0
P 215	Feeder Y3 pellets	[s]	16	11 ... 21	1
P 216	Feeder X4 pellets	[%]	100	100	0
P 217	Feeder Y4 pellets	[s]	10	5 ... 15	1
P 218	Feeder runtime in the attenuation – pellets	[s]	15	13 ... 20	1
P 219	Standstill time(delay) feeder in the attenuation – pellets	[min.]	10	5 ... 15	1
P 220	Ventilator X1 pellets	[%]	0	0	0
P 221	Ventilator Y1 pellets	[%]	8	6 ... 13	1
P 222	Ventilator X2 pellets	[%]	33	33	0
P 223	Ventilator Y2 pellets	[%]	16	11 ... 21	1
P 224	Ventilator X3 pellets	[%]	66	66	0
P 225	Ventilator Y3 pellets	[%]	36	31 ... 41	1
P 226	Ventilator X4 pellets	[%]	100	100	0
P 227	Ventilator Y4 pellets	[%]	46	41 ... 51	1
P 228	Ventilator slowing-down in the attenuation regime– pellets	[s]	3	1 ... 60	1
P 229	Ventilator output in the attenuation – pellets	[%]	100	50 ... 100	1
P 232	Outside sensor deactivation		0	0 ... 1	1
P 233	Diagnostics HC		-	-	-
P 234	Diagnostics boiler		-	-	-
P 235	Restoration of manufacturer's setting		0	0 ... 1	1
P 238	Year		-	2000 - 2050	1
P 239	Date		-	01.01. – 31.12.	Day
P 240	Time		-	00:00 – 23:59	Minute

Tab. no. 8 Parameters – Pump heating circuit

Parameter	Description	Units	Set by the manufacturer	Range	Resolution
P 1	Current outside temperature	[°C]	-	-20 ... 50	0,1
P 2	Current boiler temperature	[°C]	-	5 ... 100	0,1
P 4	Desired heating circuit temperature	[°C]	-	0 ... 80	0,1
P 5	Current temperature HW	[°C]	-	5 ... 100	0,1
P 6	Desired boiler temperature in case of HW heating	[°C]	-	0 ... 75	1
P 8	Current feeder temperature	[°C]	-	5 ... 100	0,1
P 9	Current space temperature	[°C]	-	0 ... 40	0,1
P 11	Desired boiler temperature	[°C]	-	20 ... 85	0,1
P 12	Current ventilator output	[%]	-	0 ... 100	0,1
P 15	Faults		-	0 ... 15	
P 19	Parallel shift in the heating curve	[°C]	0	-10 ... 10	1
P 20	Fuel type		1	1 ... 4	1
P 21	Slope of heating curve		1,5	0,1 ... 4	0,1

Parameter	Description	Units	Set by the manufacturer	Range	Resolution
P 22	Ventilator output when making fire	[%]	50	1 ... 100	1
P 23	Minimum boiler temperature	[°C]	50	20 ... 70	0,1
P 24	Type of requirement (auto/fixed)		0	0 ... 1	1
P 25	Boiler hysteresis	[°C]	3	1 ... 5	0,1
P 26	Maximum feeder temperature	[°C]	90	85 ... 95	1
P 27	Boiler heating deficiency	[min.]	30	10 ... 60	1
P 28	QAA position		2	1 ... 2	1
P 40	Heating circuit off/on		1	0 ... 1	1
P 41	Boiler temperature increase from the heating circuit	[°C]	5	0 ... 20	1
P 42	Warm water off/on		1	0 ... 1	1
P 43	Boiler temperature increase from HW	[°C]	15	5 ... 20	1
P 50	Boiler primary pump man/auto		1	0 ... 1	1
P 51	Boiler primary pump off/on		-	0 ... 1	1
P 52	Boiler primary pump slowing-down	[min.]	5	0 ... 60	1
P 53	Boiler primary pump switch-on temperature	[°C]	55	20 ... 60	1
P 54	Day of boiler primary pump spinning		5	0 ... 8	1
P 65	Three-way valve HW man/auto		1	0 ... 1	1
P 66	Current status of three-way valve HW		-	0 ... 1	1
P 67	HW three-way valve slowing-down	[min.]	3	0 ... 10	1
P 70	Outside temperature reset		0	0 ... 1	1
P 71	Space hysteresis	[°C]	0,5	0 ... 5	0,1
P 72	Space effect	[%]	20	0 ... 100	1
P 76	Minimum heating circuit temperature	[°C]	30	20 ... 50	1
P 77	Maximum heating circuit temperature	[°C]	80	30 ... 90	1
P 80	Building constant	[h]	10	1 ... 50	1
P 81	Temperature ECO	[°C]	-3	-5 ... 5	1
P 82	ECO automatics passive/active		-	0 ... 1	1
P 83	Temperature summer/winter	[°C]	17	8 ... 35	1
P 84	Constant summer/winter	[h]	50	1 ... 100	1
P 85	Current status summer/winter		-	0 ... 1	1
P 86	Heating system		3	0 ... 3	1
P 100	Setting the day of time schedule for HC		0	0 ... 7	1
P 101	First HC period switched on	[h:min.]	6:00	0:00 ... 23:59	1 min.
P 102	First HC period switched off	[h:min.]	22:00	0:00 ... 23:59	1 min.
P 103	Desired space temperature in the first period	[°C]	21	10 ... 30	0,1
P 104	Second period HC switched on	[h:min.]	23:59	0:00 ... 23:59	1 min.
P 105	Second period HC switched off	[h:min.]	23:59	0:00 ... 23:59	1 min.
P 106	Desired space temperature in the second period	[°C]	21	10 ... 30	0,1
P 107	Third period HC switched on	[h:min.]	23:59	0:00 ... 23:59	1 min.
P 108	Third period HC switched off	[h:min.]	23:59	0:00 ... 23:59	1 min.
P 109	Desired space temperature in the third period	[°C]	20	10 ... 30	0,1
P 110	Time schedule reset HC		0	0 ... 1	1
P 111	Desired space temperature in attenuation	[°C]	19	5 ... 25	0,1
P 120	Setting the day of time schedule for HW		0	0 ... 7	1
P 121	First period HW switched on	[h:min.]	6:00	0:00 ... 23:59	1 min.
P 122	First period HW switched off	[h:min.]	22:00	0:00 ... 23:59	1 min.
P 123	Desired temperature HW in the first period	[°C]	60	10 ... 65	1
P 124	Second period HW switched on	[h:min.]	23:59	0:00 ... 23:59	1 min.
P 125	Second period HW switched off	[h:min.]	23:59	0:00 ... 23:59	1 min.
P 126	Desired temperature HW in the second period	[°C]	55	10 ... 65	1
P 127	Third period HW switched on	[h:min.]	23:59	0:00 ... 23:59	1 min.
P 128	Third period HW switched off	[h:min.]	23:59	0:00 ... 23:59	1 min.
P 129	Desired temperature HW in the third period	[°C]	50	10 ... 65	1
P 130	Hysteresis HW	[°C]	4	1 ... 10	1

Parameter	Description	Units	Set by the manufacturer	Range	Resolution
P 131	Time schedule reset HW		0	0 ... 1	1
P 140	Feeder runtime	[s]	5	5 ... 10	0,1
P 150	Feeder X1 lignite	[%]	0	0	0
P 151	Feeder Y1 lignite	[s]	65	55 ... 75	1
P 152	Feeder X2 lignite	[%]	33	33	0
P 153	Feeder Y2 lignite	[s]	38	28 ... 48	1
P 154	Feeder X3 lignite	[%]	66	66	0
P 155	Feeder Y3 lignite	[s]	26	21 ... 31	1
P 156	Feeder X4 lignite	[%]	100	100	0
P 157	Feeder Y4 lignite	[s]	20	15 ... 25	1
P 158	Feeder runtime in the attenuation – lignite	[s]	5	3 ... 10	1
P 159	Standstill time(delay) of feeder in the attenuation – lignite	[min.]	40	10 ... 240	1
P 160	Ventilator X1 lignite	[%]	0	0	0
P 161	Ventilator Y1 lignite	[%]	30	25 ... 35	1
P 162	Ventilator X2 lignite	[%]	33	33	0
P 163	Ventilator Y2 lignite	[%]	35	30 ... 40	1
P 164	Ventilator X3 lignite	[%]	66	66	0
P 165	Ventilator Y3 lignite	[%]	48	43 ... 58	1
P 166	Ventilator X4 lignite	[%]	100	100	0
P 167	Ventilator Y4 lignite	[%]	50	45 ... 60	1
P 168	Ventilator slowing-down in the attenuation regime– lignite	[s]	30	5 ... 120	1
P 169	Ventilator output in the attenuation – lignite	[%]	100	50 ... 100	1
P 170	Feeder X1 hard coal	[%]	0	0	0
P 171	Feeder Y1 hard coal	[s]	90	80 ... 99	1
P 172	Feeder X2 hard coal	[%]	33	33	0
P 173	Feeder Y2 hard coal	[s]	42	32 ... 52	1
P 174	Feeder X3 hard coal	[%]	66	66	0
P 175	Feeder Y3 hard coal	[s]	32	27 ... 37	1
P 176	Feeder X4 hard coal	[%]	100	100	0
P 177	Feeder Y4 hard coal	[s]	27	23 ... 33	1
P 178	Feeder runtime in the attenuation – hard coal	[s]	5	3 ... 10	1
P 179	Standstill time(delay) of feeder in the attenuation – hard coal	[min.]	40	10 ... 240	1
P 200	Ventilator X1 hard coal	[%]	0	0	0
P 201	Ventilator Y1 hard coal	[%]	28	23 ... 33	1
P 202	Ventilator X2 hard coal	[%]	33	33	0
P 203	Ventilator Y2 hard coal	[%]	34	29 ... 39	1
P 204	Ventilator X3 hard coal	[%]	66	66	0
P 205	Ventilator Y3 hard coal	[%]	70	65 ... 75	1
P 206	Ventilator X4 hard coal	[%]	100	100	0
P 207	Ventilator Y4 hard coal	[%]	75	70 ... 80	1
P 208	Ventilator slowing-down in the attenuation regime– hard coal	[s]	30	5 ... 120	1
P 209	Ventilator output in the attenuation – hard coal	[%]	100	50 ... 100	1
P 210	Feeder X1 pellets	[%]	0	0	0
P 211	Feeder Y1 pellets	[s]	60	50 ... 70	1
P 212	Feeder X2 pellets	[%]	33	33	0
P 213	Feeder Y2 pellets	[s]	29	19 ... 39	1
P 214	Feeder X3 pellets	[%]	66	66	0
P 215	Feeder Y3 pellets	[s]	16	11 ... 21	1
P 216	Feeder X4 pellets	[%]	100	100	0
P 217	Feeder Y4 pellets	[s]	10	5 ... 15	1
P 218	Feeder runtime in the attenuation – pellets	[s]	15	13 ... 20	1
P 219	Standstill time(delay) of feeder in the attenuation – pellets	[min.]	10	5 ... 15	1

Parameter	Description	Units	Set by the manufacturer	Range	Resolution
P 220	Ventilator X1 pellets	[%]	0	0	0
P 221	Ventilator Y1 pellets	[%]	8	6 ... 13	1
P 222	Ventilator X2 pellets	[%]	33	33	0
P 223	Ventilator Y2 pellets	[%]	16	11 ... 21	1
P 224	Ventilator X3 pellets	[%]	66	66	0
P 225	Ventilator Y3 pellets	[%]	36	31 ... 41	1
P 226	Ventilator X4 pellets	[%]	100	100	0
P 227	Ventilator Y4 pellets	[%]	46	41 ... 51	1
P 228	Ventilator slowing-down in the attenuation regime– pellets	[s]	3	1 ... 60	1
P 229	Ventilator output in the attenuation – pellets	[%]	100	50 ... 100	1
P 232	Outside sensor deactivation		1	0 ... 1	1
P 233	Diagnostics HC		-	-	-
P 234	Diagnostics boiler		-	-	-
P 235	Restoration of manufacturer's setting		0	0 ... 1	1
P 238	Year		-	2000 - 2050	1
P 239	Date		-	01.01. – 31. 12.	Day
P 240	Time		-	00:00 – 23:59	Minute

6.2.1 Description of SAPHIR regulator parameters

P 1	Current outside temperature	[°C]
	Current outside temperature displayed. The lowest displayed value of outside temperature is -20 °C.	
P 2	Current boiler temperature	[°C]
	Current boiler outlet temperature displayed.	
P 3	Current heating circuit temperature	[°C]
	Current heating circuit temperature displayed	
P 4	Desired heating circuit temperature	[°C]
	Current desired heating circuit temperature displayed	
P 5	Current temperature HW	[°C]
	Current HW temperature displayed	
P 6	Desired boiler temperature in case of HW heating	[°C]
	Current desired boiler outlet temperature in case of water demand on heating displayed	
P 7	Current warm water thermostat status	[°C]
	Current HW thermostat status displayed	
P 8	Current feeder temperature	[°C]
	Current feeder temperature displayed	
P 9	Current space temperature	[°C]
	Current space temperature displayed	
P 10	Current position of three-way mixing valve	[%]
	Current position of three-way mixing valve displayed	
P 11	Desired boiler temperature	[°C]
	Current desired boiler outlet temperature displayed	
P 12	Current ventilator output	[%]
	Current ventilator output displayed	

P 15	Faults	
	Current boiler fault displayed. Description of individual faults see tab. no. 9. In case 0 is on the line no fault is detected.	
P 19	Parallel shift in the heating curve	[°C]
	By increasing the value the parallel shift in heating curve will occur (parameter P 21) thus the desired heating water temperature will be increased	
P 20	Fuel type	
	Selection of required fuel (value 1, 2, 3 or 4) 1 – lignite 2 – hard coal 3 – wood pellets 4 – Manual operation Note: Value 4 Manual operation is described in detail in chap. no. 7.	
P 21	Slope of heating curve	
	The value in this parameter shows the preset curve for heating of the heating circuit. The value depends on many factors. The correct value must be found out.	
P 22	Ventilator output when making fire	[%]
	Setting of desired ventilator output when making fire depending on the type of used fuel. Recommended values: - lignite and hard coal 40 - 50 % - wood pellets 20 %	
P 23	Minimum boiler temperature	[°C]
	Setting of minimum boiler temperature. The manufacturer insists on min. 50 °C boiler temperature. This minimum boiler temperature is maintained in all regimes.	
P 24	Type of requirement (auto/fixe)	
	Setting of the type of requirement for heating: By default there is used the auto – value 0 type of requirement . The boiler will heat automatically to the calculated desired water temperature. It is possible to use the fixed – value 1 type of requirement . The boiler will heat to the fixedly set outlet water temperature. The temperature set by the manufacturer is 70 °C. By keys (+ up, - down) of QAA 88 device we can increase or reduce the temperature set by the manufacturer by 15 °C. But QAA 88 device display shows the current space temperature if the QAA 88 device is as the space unit. Note: In case of boiler operation to fixed temperature the automatic summer/winter switching –over is always active. The fixed operation is only suitable in case the boiler is used as the source of heat. Boiler fixed operation is automatically activated in case of outside sensor fault or its disconnection. The use of auto type of requirement is recommended by the manufacturer.	
P 25	Boiler hysteresis	[°C]
	The boiler outlet temperature (modulation zone) can be exceeded by the value set in this parameter..	
P 26	Maximum feeder temperature	[°C]
	Setting of feeder maximum temperature: Once this temperature has been reached on the fuel feeder sensor the feeder starts to move fuel at the accelerated pace (shift 20 s, delay 10 s) until the temperature has dropped below the set value. In case the feeder temperature has not dropped within 7 minutes (fixedly set software value) the feeder will shut down. Manufacturer recommends the value set by him to be retained.	

P 27	Boiler heating deficiency	[min.]
	<p>If 40 °C boiler temperature hasn't been reached within the time set in this parameter the fault message „4“ - boiler extinction followed by boiler shut down will occur.</p> <p>Note: The boiler display is flickering and the fault number is displayed by parameter P 15.</p>	
P 28	QAA position Setting whether we use AQQ 88 device as the space unit (value 2) or the boiler unit (value 1)	
	<ol style="list-style-type: none"> boiler unit – it is assumed that the device is positioned directly at the boiler. The current boiler temperature is displayed on the display and the control is purely equithermal without space effect. By the keys (arrow + up, - down) we correct the desired current boiler temperature. space unit - the device is positioned in the space (reference room). The current space temperature is displayed on the display and the control is equithermal with the space effect. By the keys (arrow + up, - down) we change the desired space temperature in the range ± 3 °C from the temperature set on line no. 103, 106 and 109. This change applies till the next time change. The same applies to the attenuation temperature. <p>Note: If the device is positioned in the space, but we select the Boiler unit setting then instead of space temperature the boiler temperature will be displayed on the display and the space effect will not be taken into account. Heating is purely equithermal without space effect.</p>	
P 40	Heating circuit off/on	
	<p>By this parameter we can switch off heating of the heating circuit including the pump of heating circuit and three-way mixing valve if it is used in the application.</p> <p>Value 0 – Switched off Value 1 – Switched on</p>	
P 41	Boiler temperature increase from the heating circuit	[°C]
	<p>Setting of boiler temperature increase from currently desired heating circuit temperature</p> <p>Note: This value set by the manufacturer can be reduced to approx. 1 – 2 °C if the three-way mixing valve is installed in such distance from the boiler that no outlet water temperature losses into the space occur.</p>	
P 42	Warm water off/on	
	<p>By this parameter we can switch off warm water heating incl. the warm water pump (warm water three-way valve) according to the used application.</p> <p>Value 0 – Switched off Value 1 – Switched on</p>	
P 43	Boiler temperature increase from HW	[°C]
	<p>Setting of boiler temperature increase from currently desired warm water temperature.</p>	
P 50	Boiler primary pump man/auto	
	<p>Setting of the pump control type. Man – manual pump run, Auto – automatic pump run according to current requirements.</p> <p>Value 0 – Man Value 1 – Auto</p>	
P 51	Boiler primary pump off/on	
	<p>Primary pump switched on in case we have selected value 0 – Man on the line no.50.</p> <p>Value 0 – Switched off Value 1 – Switched on</p> <p>Note: In case value 0 is selected in parameter P 50 it is necessary to select here the value 1. If it be to the contrary the pump will not be active.</p>	

P 52	Boiler primary pump slowing-down	[min.]
	We select boiler pump slowing-down on this line.	
P 53	Boiler primary pump switch-on temperature	[°C]
	Once this set boiler temperature has been achieved the boiler primary pump will switch on. The pump will switch off once the temperature has dropped by 5 °C below the temperature set for pump switching-on.	
P 54	Day of boiler primary pump spinning	
	On the determined day the pump spinning will be done at 12:00 h for 30 sec. Value 1 - 7 – corresponds to days from Monday to Sunday Value 0 –primary pump spinning is not active Value 8 – primary pump spinning is active every day Note: If at this time the pump is working the function is not active	
P 55	Heating circuit pump man/auto	
	Setting of pump control type. Man – pump manual run, Auto – pump automatic run according to current requirements. Value 0 – Man Value 1 – Auto	
P 56	Heating circuit pump off/on	
	Circuit pump switched on in case we have selected value 0 – Man on the line no. 55. Value 0 – Switched off Value 1 – Switched on Note: In case value 0 is selected in parameter P 55 it is necessary to select here the value 1. If it be to the contrary the pump will not be active.	
P 57	Heating circuit pump slowing-down	[min.]
	We select heating circuit pump slowing-down on this line.	
P 58	Day of heating circuit pump spinning	
	On the determined day the pump spinning will be done at 12:00 h for 30 sec. Value 1 - 7 – corresponds to days from Monday to Sunday Value 0 –pump spinning is not active Value 8 –pump spinning is active every day Note: If at this time the pump is working the function is not active	
P 59	Warm water pump man/auto	
	Setting of type of pump control; Man –pump manual run, Auto – pump automatic run according to the current requirements. Value 0 – Man Value 1 – Auto Attention! The value 0 is only designed for HW pump service testing. The permanent setting of pump manual run can result in water heater chilling. Therefore keep the set value1.	
P 60	Warm water pump off/on	
	Warm water pump switched on in case we have selected value 0 – Man on the line no. 59. Value 0 – Switched off Value 1 – Switched on Note: In case the value 0 is selected in P 59 parameter it is necessary to select here the value 1. If it be to the contrary the pump will not be active.	
P 61	Warm water pump slowing-down	[min.]
	We select warm water pump slowing-down on this line	

P 62	Day of warm water pump spinning	
	On the determined day the pump spinning will be done at 12:00 h for 30 sec. Value 1 - 7 – corresponds to days from Monday to Sunday Value 0 –primary pump spinning is not active Value 8 – primary pump spinning is active every day Note: If at this time the pump is working the function is not active	
P 65	Three-way HW valve man/auto	
	Setting of type of HW three-way valve control: Man –valve into HW circuit permanently open Auto – automatic three-way valve reversing according to requirement. Value 0 – Man Value 1 – Auto ATTENTION! Value 0 is only designed for valve functionality service testing.	
P 66	Current status of HW three-way valve	
	Display of current status of HW three-way valve In case the value 0 is selected in P 65 parameter we activate the three-way valve in this P 66 parameter by selecting the value 1.	
P 67	HW three-way valve slowing-down	[min.]
	Over this set period HW three-way valve is kept open into HW circuit when the desired HW temperature has been reached. If the boiler temperature after the HW preparation completion is higher than HW desired temperature plus 5 °C the boiler slowing-down into HW circuit is active and is followed by HW three-way valve slowing-down. If after the HW preparation completion the boiler temperature is not higher than HW desired temperature plus 5 °C the slowing-down into from boiler is not active, but HW three-way valve slowing-down starts immediately.	
P 70	Outside temperature reset	
	By this parameter activation we will set the outside temperature values to zero. Thenceforth the regulator starts to count new outside temperature values. Value 1 – activates zeroing	
P 71	Space hysteresis	[°C]
	Setting the value of space temperature excess; only after the space desired temperature incl. the value increase set in this parameter has been reached the boiler operation into the heating circuit will be shut down. The boiler operation into the heating circuit will restart after the space temperature has dropped to the space desired temperature.	
P 72	Space effect	[%]
	By setting this parameter we correct the equithermal control by the space effect. The higher is the set value the more the space effect is taken into account. Note: Setting 100 % regards the pure space control. Note: This parameter is active in case the QAA 88 device is selected as the space unit (line no. 28 value 2) and the outside sensor is used.	
P 76	Minimum heating circuit temperature	[°C]
	Setting the minimum desired temperature for heating circuit. Note: The minimum boiler temperature is taken as the minimum heating circuit temperature in case of the version without three-way mixing valve.	
P 77	Maximum heating circuit temperature	[°C]
	Setting of maximum desired temperature for heating circuit.	

P 80	Building constant	[h]
	<p>Heating is influenced by setting this parameter. The linkage of building temperatures responses to changing outside temperature depending on current building structure is taken into account by this parameter.</p> <p>Value 0, 1 – wood structure (setting the value 1 is recommended by the manufacturer)</p> <p>Value 1, 2 or 3 – panel buildings (setting the value 3 is recommended by the manufacturer 3)</p> <p>Value 10 – brickwork buildings</p>	
P 81	ECO temperature	[°C]
	<p>The heating circuit requirement is directly influenced by setting this value. Heating is blocked in case the difference between the current desired space temperature and attenuated outside temperature is lower than the value set in this parameter. The line 82 shows whether this function is active</p> <p>Note: This function does not count with current outside temperature.</p>	
P 82	ECO automatics passive/active	
	<p>ECO function image.</p> <p>Value 0 – passive (the function is not active it means heating isn't blocked)</p> <p>Value 1 – active (the function is active it means heating is blocked)</p>	
P 83	Summer/winter temperature	[°C]
	<p>Setting the outside temperature at which the heating circuit requirement will be ignored.</p> <p>Note: The evaluation on the basis of average outside temperatures.</p>	
P 84	Summer/winter constant	[h]
	<p>By setting this value we determine the time for calculation of average outside temperature in connection with line no. 83.</p>	
P 85	Summer/winter current status	
	<p>Summer/winter current status image.</p> <p>Value 0 – winter (the function is not active it means heating isn't blocked)</p> <p>Value 1 – summer (the function is active it means heating is blocked)</p>	
P 86	Heating system	
	<p>Setting the type of heating bodies.</p> <p>Value 0 – floor heating</p> <p>Value 1 – convectors</p> <p>Value 2 – plate radiators</p> <p>Value 3 – cast iron radiators</p>	
P 87	HC antifreeze protection off/on	
	<p>Setting the heating circuit antifreeze protection on the basis of outside temperature</p> <p>If the outside temperature is +1,5 °C and higher the heating circuit pump only will slow down after the requirement for heating has ceased.</p> <p>If the outside temperature is in the range from +1,5 to -4 °C the heating circuit pump will be switched on every 6 hours for the period of 10 minutes.</p> <p>If the outside temperature is in the range from -4 °C and lower the heating circuit pump will be permanently switched on.</p> <p>Pump switch-off hysteresis is 0,5 °C.</p> <p>Value 0 – function isn't active</p> <p>Value 1 – function is active</p> <p>Keeping the function activated is recommended by the manufacturer.</p>	
P 88	Servo overrun time	[s]
	<p>This value depends on the used three-way mixing valve of the heating branch and it is taken from the catalogue sheet. If you use three-way valve SQK 34 then the correct value is already set.</p>	

P 100	Setting the day of time schedule for HC	
	Setting the day of week required for setting the individual heating periods Value 1 - 7 – corresponds to the days from Monday to Sunday, we set it separately every day Value 0 – setting all days at once	
P 101	First HC period switched on	[h:min.]
	Setting the time of switching-on the first period for HC heating Note: It isn't necessary to use the second and third period	
P 102	First HC period switched off	[h:min.]
	Setting the switching-off time of the first period for HC heating	
P 103	Desired space temperature in the first period	[°C]
	Setting the desired space temperature in the first HC period	
P 104	Second HC period switched on	[h:min.]
	Setting the switching-on time of the second period for HC heating	
P 105	Second HC period switched off	[h:min.]
	Setting the switching-off time of the second period for HC heating	
P 106	Desired space temperature in the second period	[°C]
	Setting the desired space temperature in the second HC period	
P 107	Third HC period switched on	[h:min.]
	Setting the switching-on time of the third period for HC heating	
P 108	Third period HC switched off	[h:min.]
	Setting the switching-off time of the third period for HC heating	
P 109	Desired space temperature in the third period	[°C]
	Setting the desired space temperature in the third HC period	
P 110	HC time schedule reset	
	By this parameter activation the time regime is reset into manufacturer's setting. Value 1 – activation	
P 111	Desired space temperature in attenuation	[°C]
	Setting the desired space temperature at the time outside the time period	
P 120	Setting the day of time schedule for HW	
	Setting the day of the week required for setting the individual HW heating periods Value from 1 to 7 – corresponds to days from Monday to Sunday and we set it separately every day Value 0 – setting all days at once	
P 121	First period HW switched on	[h:min.]
	Setting the time of switching-on the first period for HW heating Note: It isn't necessary to use the second and third period	
P 122	First period HW switched off	[h:min.]
	Setting the time of switching-off the first period for HW heating	
P 123	Desired HW temperature in the first period	[°C]
	Setting the desired HW temperature in the first period Note: In application with HW thermostat the value must correspond to the temperature set on HW thermostat.	
P 124	Second period HW switched on	[h:min.]
	Setting the time of switching –on the second period for HW heating	

P 125	Second period HW switched off	[h:min.]
	Setting the time of switching -off the second period for HW heating	
P 126	Desired HW temperature in the second period	[°C]
	Setting the desired HW temperature in the second period Note: In application with HW thermostat the value must correspond to the temperature set on HW thermostat.	
P 127	Third period HW switched on	[h:min.]
	Setting the time of switching –on the third period for HW heating	
P 128	Third period HW switched off	[h:min.]
	Setting the time of switching –off the third period for HW heating	
P 129	Desired HW temperature in the third period	[°C]
	Setting the desired HW temperature in the third period Note: In application with HW thermostat the value must correspond to the temperature set on HW thermostat.	
P 130	HW Hysteresis	[°C]
	This value relates to the desired HW temperature. In case the HW temperature has dropped by this value below the HW set desired value HW heating will start again.	
P 131	HW time schedule reset	
	By this parameter activation the time regime returns to the manufacturer's setting Value 1 – activation	
P 140	Feeder runtime	[s]
	Feeder runtime in automatic regime	
P 150	Feeder X1 lignite	[%]
	It regards the percentage value of output. The value 0 represents the min. output and the feeder standstill time of parameter 151 is assigned to this value Note: This parameter cannot be changed	
P 151	Feeder Y1 lignite	[s]
	Setting the feeder standstill time for HU fuel relating to 0% output	
P 152	Feeder X2 lignite	[%]
	It regards the percentage value of output. The value 33 represents the 33% output and the feeder standstill time of parameter 153 is assigned to this value. Note: This parameter cannot be changed	
P 153	Feeder Y2 lignite (HU)	[s]
	Setting the feeder standstill time for HU fuel relating to 33% output	
P 154	Feeder X3 lignite	[%]
	It regards the percentage value of output. The value 33 represents the 66% output and the feeder standstill time of parameter 155 is assigned to this value Note: This parameter cannot be changed	
P 155	Feeder Y3 lignite	[s]
	Setting the feeder standstill time for HU fuel relating to 66% output	
P 156	Feeder X4 lignite	[%]
	It regards the percentage value of output. The value 33 represents the 100 % output and the feeder standstill time of parameter 157 is assigned to this value. Note: This parameter cannot be changed	
P 157	Feeder Y4 lignite	[s]
	Setting the feeder standstill time for HU fuel relating to 100% output	

P 158	Feeder runtime in the attenuation – lignite	[s]
	Setting the feeder runtime in the attenuation regime for HU fuel	
P 159	Standstill time(delay) of feeder in the attenuation – lignite	[min.]
	Standstill of feed screw in the attenuation regime for HU fuel	
P 160	Ventilator X1 lignite	[%]
	It regards the percentage value of ventilator output. The value 0 represents min. ventilator output and the actual ventilator output of parameter 161 is assigned to this value. Note: This parameter cannot be changed	
P 161	Ventilator Y1 lignite	[%]
	Setting the actual ventilator output for HU fuel relating to 0% ventilator output	
P 162	Ventilator X2 lignite	[%]
	It regards the percentage value of ventilator output The value 33 represents 33% ventilator output and the actual ventilator output of parameter 163 is assigned to this value. Note: This parameter cannot be changed	
P 163	Ventilator Y2 lignite	[%]
	Setting the actual ventilator output for HU fuel relating to 33% ventilator output	
P 164	Ventilator X3 lignite	[%]
	It regards the percentage value of ventilator output The value 66 represents 66% ventilator output and the actual ventilator output of parameter 165 is assigned to this value. Note: This parameter cannot be changed	
P 165	Ventilator Y3 lignite	[%]
	Setting the actual ventilator output for HU fuel relating to 66% ventilator output	
P 166	Ventilator X4 lignite	[%]
	It regards the percentage value of ventilator output The value 100 represents 100% ventilator output and the actual ventilator output of parameter 167 is assigned to this value. Note: This parameter cannot be changed	
P 167	Ventilator Y4 lignite	[%]
	Setting the actual ventilator output for HU relating to 100% ventilator output	
P 168	Ventilator slowing-down in the attenuation regime– lignite	[s]
	Setting the ventilator slowing-down in the attenuation regime against the feeder runtime in the attenuation regime	
P 169	Ventilator output in the attenuation regime– lignite	[%]
	Setting the ventilator output in the attenuation regime	
P 170	Feeder X1 hard coal	[%]
	It regards the percentage value of output. The value 0 represents min. output and feeder standstill time of parameter 171 is assigned to this value. Note: This parameter cannot be changed	
P 171	Feeder Y1 hard coal(ČU)	[s]
	Setting the feeder standstill time for ČU fuel relating to 0% output	
P 172	Feeder X2 hard coal	[%]
	It regards the percentage value of output. Value 33 represents 33% output and feeder standstill time of parameter 173 is assigned to this value. Note: This parameter cannot be changed	
P 173	Feeder Y2 hard coal	[s]
	Setting the feeder standstill time for ČU fuel relating to 33% output	

P 174	Feeder X3 hard coal	[%]
	It regards the percentage value of output. The value 66 represents 66% output and feeder standstill time of parameter 175 is assigned to this value. Note: This parameter cannot be changed	
P 175	Feeder Y3 hard coal	[s]
	Setting the feeder standstill time for ČU as the fuel relating to 66% output	
P 176	Feeder X4 hard coal	[%]
	It regards the percentage value of output. The value 100 represents 100% output and feeder standstill time of parameter 177 is assigned to this value. Note: This parameter cannot be changed	
P 177	Feeder Y4 hard coal	[s]
	Setting the feeder standstill time for ČU as the fuel relating to 100% output	
P 178	Feeder runtime in the attenuation regime– hard coal	[s]
	Setting the feeder runtime in the attenuation regime for ČU as the fuel	
P 179	Standstill time(delay) of feeder in the attenuation – hard coal	[min.]
	Standstill time of the feed screw in the attenuation regime for ČU as the fuel	
P 200	Ventilator X1 hard coal	[%]
	It regards the percentage value of ventilator output The value 0 represents min. ventilator output and actual ventilator output of parameter 201 is assigned to this value. Note: This parameter cannot be changed	
P 201	Ventilator Y1 hard coal	[%]
	Setting the actual ventilator output for ČU as the fuel relating to 0% ventilator output	
P 202	Ventilator X2 hard coal	[%]
	It regards the percentage value of ventilator output The value 33 represents 33% ventilator output and actual ventilator output of parameter 203 is assigned to this value. Note: This parameter cannot be changed	
P 203	Ventilator Y2 hard coal	[%]
	Setting the actual ventilator output for ČU as the fuel relating to 33% ventilator output	
P 204	Ventilator X3 hard coal	[%]
	It regards the percentage value of ventilator output The value 66 represents 66% ventilator output and actual ventilator output of parameter 205 is assigned to this value. Note: This parameter cannot be changed	
P 205	Ventilator Y3 hard coal	[%]
	Setting the actual ventilator output for ČU as the fuel relating to 66% ventilator output	
P 206	Ventilator X4 hard coal	[%]
	It regards the percentage value of ventilator output The value 100 represents 100% ventilator and actual ventilator output of parameter 207 is assigned to this value. Note: This parameter cannot be changed	
P 207	Ventilator Y4 hard coal	[%]
	Setting the actual ventilator output for ČU as the fuel relating to 100% ventilator output	
P 208	Ventilator slowing-down in the attenuation regime– hard coal	[s]
	Setting the ventilator slowing-down in the attenuation regime against the feeder runtime in the attenuation regime	
P 209	Ventilator output in the attenuation regime – hard coal	[%]
	Setting the ventilator output in the attenuation regime	

P 210	Feeder X1 pellets	[%]
	It regards the percentage value of output. The value 0 represents min. output and feeder standstill time of parameter 211 is assigned to this value. Note: This parameter cannot be changed	
P 211	Feeder Y1 pellets	[s]
	Setting the feeder standstill time for pellets as the fuel relating to 0% output	
P 212	Feeder X2 pellets	[%]
	It regards the percentage value of output. The value 33 represents 33% output and feeder standstill time of parameter 213 is assigned to this value. Note: This parameter cannot be changed	
P 213	Feeder Y2 pellets	[s]
	Setting the feeder standstill time for pellets as the fuel relating to 33% output	
P 214	Feeder X3 pellets	[%]
	It regards the percentage value of output. Value 66 represents 66% output and feeder standstill time of parameter 215 is assigned to this value. Note: This parameter cannot be changed	
P 215	Feeder Y3 pellets	[s]
	Setting the feeder standstill time for pellets as the fuel relating to 66% output	
P 216	Feeder X4 pellets	[%]
	It regards the percentage value of output. Value 100 represents 100% output and feeder standstill time of parameter 21 is assigned to this value 7. Note: This parameter cannot be changed	
P 217	Feeder Y4 pellets	[s]
	Setting the feeder standstill time for pellets as the fuel relating to 100% output	
P 218	Feeder runtime in the attenuation – pellets	[s]
	Setting the feeder runtime in the attenuation regime for pellets as the fuel	
P 219	Standstill time(delay) of feeder in the attenuation – pellets	[min.]
	Standstill time of the feed screw in the attenuation regime for pellets as the fuel	
P 220	Ventilator X1 pellets	[%]
	It regards the percentage value of ventilator output The value 0 represents min. ventilator output and the actual ventilator output of parameter 221 is assigned to this value. Note: This parameter cannot be changed	
P 221	Ventilator Y1 pellets	[%]
	Setting the actual ventilator output for pellets as the fuel relating to 0% ventilator output	
P 222	Ventilator X2 pellets	[%]
	It regards the percentage value of ventilator output Value 33 represents 33% ventilator output and the actual ventilator output of parameter 223 is assigned to this value. Note: This parameter cannot be changed	
P 223	Ventilator Y2 pellets	[%]
	Setting the actual ventilator output for pellets as the fuel relating to 33% ventilator output	
P 224	Ventilator X3 pellets	[%]
	It regards the percentage value of ventilator output Value 66 represents 66% ventilator output and the actual ventilator output of parameter 225 is assigned to this value at parameter 225. Note: This parameter cannot be changed	

P 225	Ventilator Y3 pellets	[%]
	Setting the actual ventilator output for pellets as the fuel relating to 66% ventilator output	
P 226	Ventilator X4 pellets	[%]
	It regards the percentage value of ventilator output Value 100 represents 100% ventilator output and the actual ventilator output of parameter 227 is assigned to this value. Note: This parameter cannot be changed	
P 227	Ventilator Y4 pellets	[%]
	Setting the actual ventilator output for pellets as the fuel relating to 100% ventilator output	
P 228	Ventilator slowing-down in the attenuation regime– pellets	[s]
	Setting the ventilator slowing-down in the attenuation regime against the feeder runtime in the attenuation regime	
P 229	Ventilator output in the attenuation – pellets	[%]
	Setting the ventilator output in the attenuation regime	
P 232	Outside sensor deactivation	
	The value 0 – outside sensor deactivation; this deactivation can only be used in case the QAA 88 device is as the space unit and then it regards the pure space control. The value 1 – active outside sensor Note: The use of the outside sensor is recommended by the manufacturer	
P 233	HC Diagnostics	
	The represented value serves for service purposes and current HC status identification.	
P 234	Boiler diagnostics	
	The represented value serves for service purposes and current boilerstatus identification..	
P 235	Restoration of manufacturer’s setting	
	The value 1 – activates the parameter and the manufacturer’s setting is restored.	
P 238	Year	
	Settting the current year	
P 239	Date	
	Settting the current date	
P 240	Time	
	Settting the current time	

6.3 QAA 88 device

The space or output water current temperature is displayed on the display during the operation depending on the use of this device (parameter P 28). The value is displayed in resolution 0,5 °C. By pressing the key **plus** or **minus** the desired temperature is displayed.







The displaying cursor is in the lower part of the display and it displays the current status of the device and ventilator. In case the cursor is above  symbol (ON – OFF) the heat requirement is ignored (ventilator and feeder do not run and other control and a security elements are active). The device is switched on by means of right-hand key ESC. The cursor jumps above the symbol (description) Auto.



Fig. no. 23 QAA 88 device

Then the cursor moves according to the boiler current status. Small ventilator symbol represents 0 – 33 %

 Auto    ventilator output, the middle-sized ventilator symbol represents 33 - 66 % ventilator output and big ventilator symbol 66 - 100 % ventilator output. On the left –hand side part of display the cursor is displayed in case of demand on

 heating  , besides the boiler minimum temperature when making fire and in boiler fixed run. The cursor flickers during the warm water heating.

In case of the manual regime –the ventilator run (pressing the blue key) the QAA 88 device display will flicker. It does not regard any fault. The value „0“ is in P 15 parameter. The ventilator run in manual regime will be terminated by pressing the blue key again and the display stops flickering.

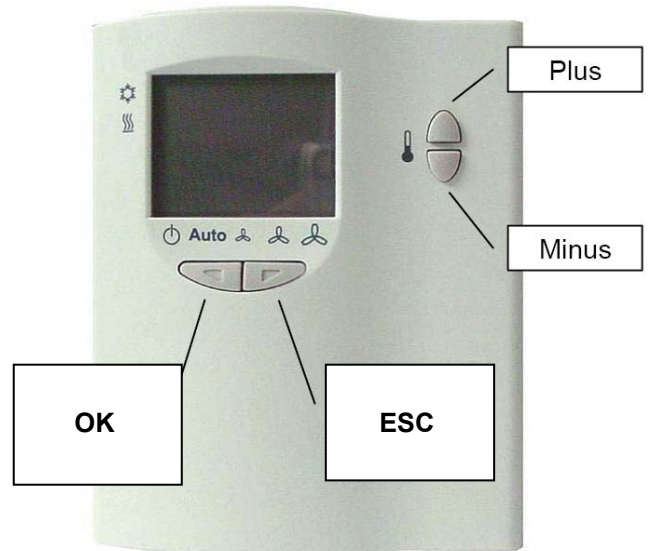

Fig. no. 24 Description of device QAA 88

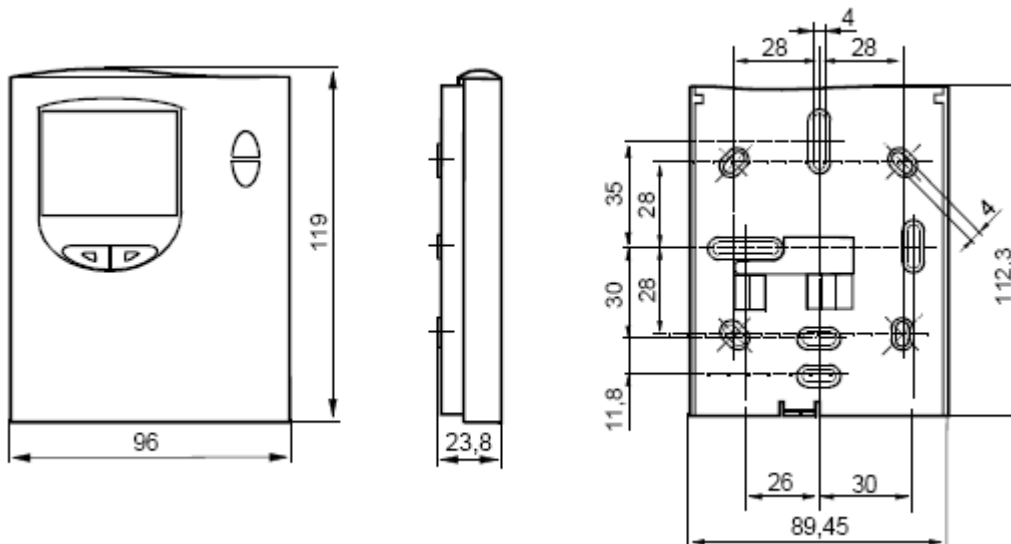

Fig. no. 25 Connecting dimensions of device QAA 88

6.3.1 Parameters setting and displaying

Parameters setting

If you want to change parameters take following steps:

- Press simultaneously the keys **OK**, **ESC** and **- minus** – blank display will appear.
- Press 2x key **- minus** and n0 appears on the display.
- Press 2x key **+ plus** and n3 appears on the display.
- Confirm with key **OK**.
- **P** appears on the display and after approx. 2 sec. the digit **1** is displayed.
- By the key **OK** the parameter value is displayed.
- By the key **+ plus** or **- minus** the displayed value can be changed.
- By the key **OK** confirm the changed value.
- By the key **ESC** leave the parameter without any change
- Select the next parameter by the key **+ plus** or **- minus** and repeat the whole procedure.

Attention!

After the completion of making changes in parameters always check whether QAA 88 device is switched on (cursor is above the Auto symbol).

Parameters displaying

If you only want to display the set parameters without the possibility to make any change take following steps:

- Press simultaneously the keys **OK, ESC a – minus** – blank display will appear.
- Press 2x key **– minus** and n0 appears on the display.
- Press 1x key **+ plus** and n2 appears on the display.
- Confirm with **OK** key.
- **d1** appears on the display and after approx. 2 sec. the digit **1** is displayed
- By the key **OK** the parameter value is displayed
- By the key **OK** or **ESC** leave the parameter without any change
- Select the next parameter by the key **+ plus** or **– minus** and repeat the whole procedure.

If during setting, changing or viewing the parameters the key is not pressed for 3 minutes the QAA 88 device will return to the introductory display.

6.3.1.1 Fuel feeder and ventilator performance curve – lignite

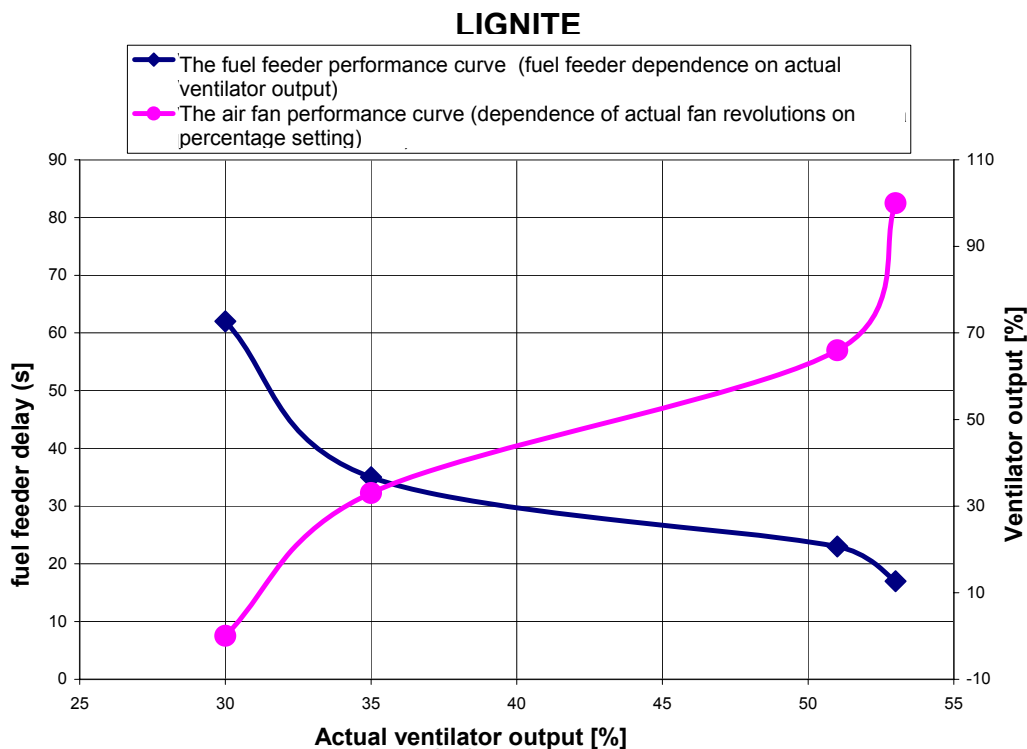

where:

62 s...is Feeder Y1 lignite – parameter no. 151
 35 s...is Feeder Y2 lignite – parameter no. 153
 23 s...is Feeder Y3 lignite – parameter no. 155
 17 s...is Feeder Y4 lignite – parameter no. 157

30 %...is Ventilator Y1 lignite – parameter no. 161
 35 %...is Ventilator Y2 lignite – parameter no. 163
 51 %...is Ventilator Y3 lignite – parameter no. 165
 53 %...is Ventilator Y4 lignite – parameter no. 167

6.3.1.2 Fuel feeder and ventilator performance curve – hard coal

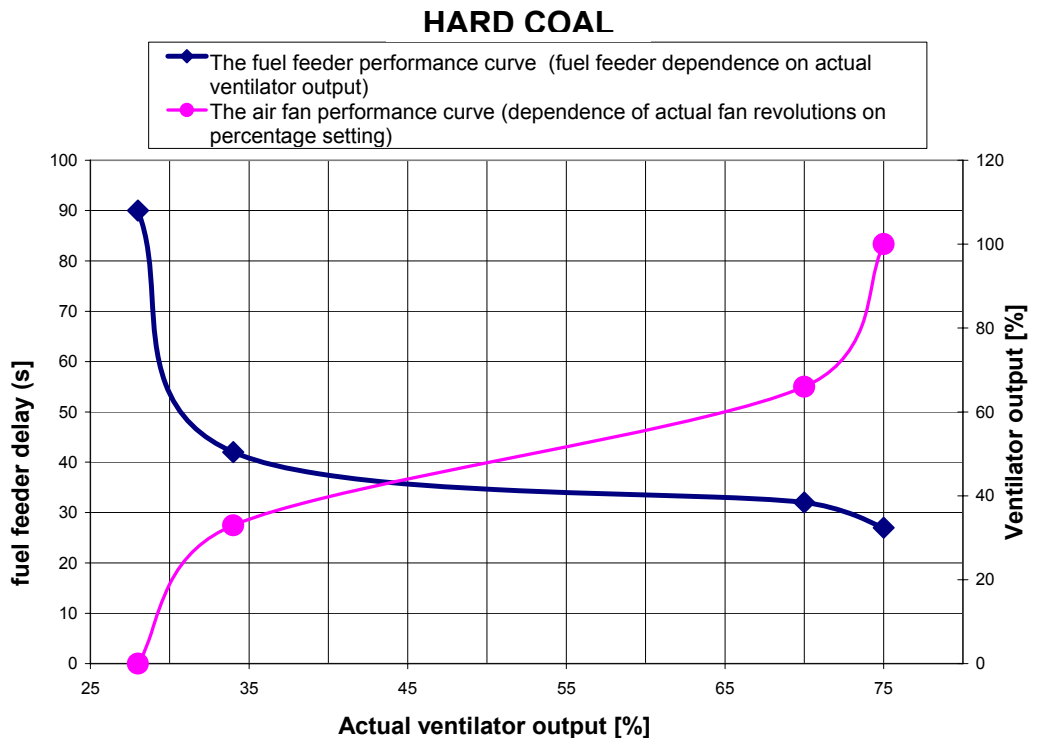

where:

90 s...is Feeder Y1 hard coal – parameter no. 171
 42 s...is Feeder Y2 hard coal – parameter no. 173
 32 s...is Feeder Y3 hard coal – parameter no. 175
 27 s...is Feeder Y4 hard coal – parameter no. 177

28 %...is Ventilator Y1 hard coal – parameter no. 201
 34 % is Ventilator Y2 hard coal – parameter no. 203
 70 % is Ventilator Y3 hard coal – parameter no. 205
 75 % is Ventilator Y4 hard coal – parameter no. 207

6.3.1.3 Fuel feeder and ventilator performance curve – wood pellets

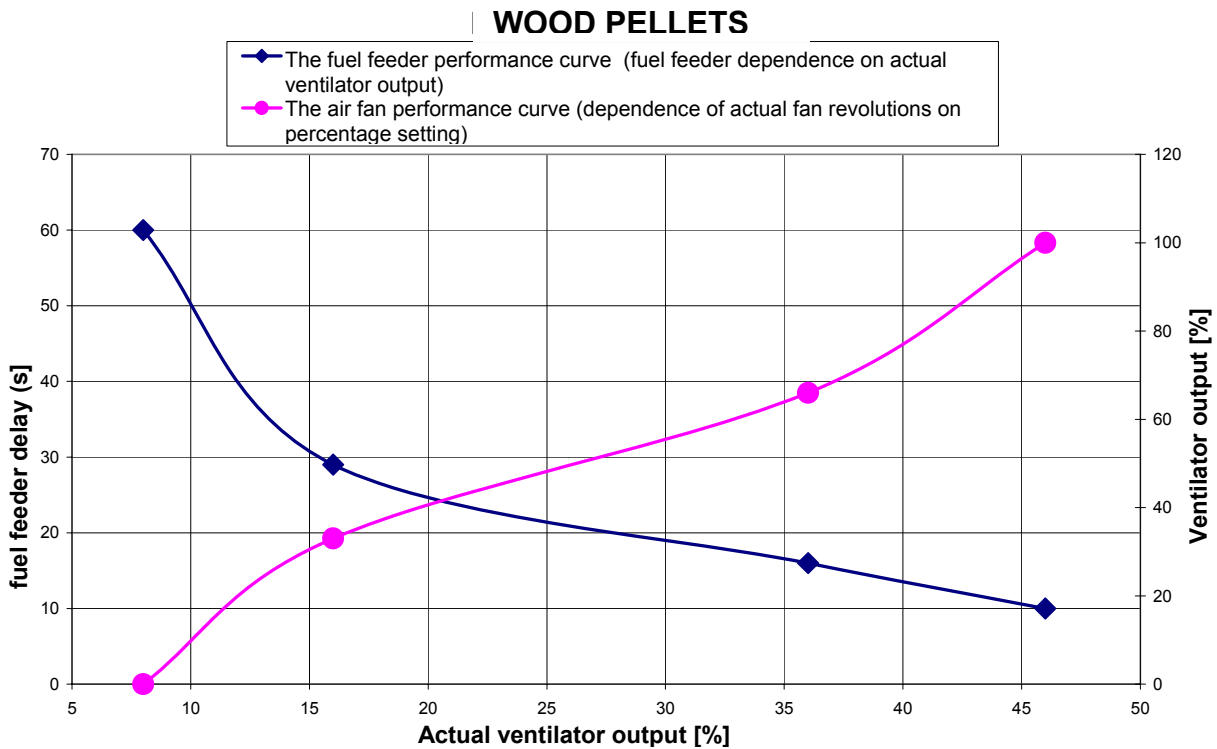

where:

60 s...is Feeder Y1 pellets – parameter no. 211
 29 s...is Feeder Y2 pellets – parameter no. 213
 16 s...is Feeder Y3 pellets – parameter no. 215
 10 s...is Feeder Y4 pellets – parameter no. 217

8 %...is Ventilator Y1 pellets – parameter no. 221
 16 %...is Ventilator Y2 pellets – parameter no. 223
 36 %...is Ventilator Y3 pellets – parameter no. 225
 46 %...is Ventilator Y4 pellets – parameter no. 227

The feeder runtime is given by P 140 parameter and it applies to all fuels except the fuel type 4 – Manual operation. The change in fuel is selected by P 20 parameter. The delays and percentage outputs are already preset.

6.3.2 Faults

The faults are displayed by flickering display of QAA 88 device. Current fault number is displayed in P 15 parameter. In case more faults occur simultaneously first of all the fault with higher number will be displayed.

The non-reversible fault 4 must be quitted after its elimination which is done on the introductory display of QAA device (i.e. leave P 15 parameter of the device up to the introductory display) by the simultaneous pressing of keys (+arrow up,- arrow down) for the period of approx. 3 sec. Display flickering will disappear. The reversible faults disappear automatically after their elimination.

In case of fault 10 - of heating branch sensor (only in case of mixing heating circuit) the three-way mixing valve closes. As the temporary variant (before we replace the sensor) we can select the boiler operation at the fixed temperature (P 24 parameter) plus the heating branch three-way mixing valve switch-over to **MAN** position. We select setting of heating branch three-way mixing valve manually. After the fault elimination we again select the automatic boiler operation and we switch over the three-way mixing valve back to **AUTO** position. Until the heating branch sensor is replaced the fault is signalled on QAA 88 device.

In case of fault 1 i.e. exceeding of max. boiler temperature the boiler might be shut down through the safety thermostat set to approx. 100 °C. This fault is non-reversible and it is necessary to de-block the safety thermostat after the boiler has cooled down. The de-blocking button is found under the black plastic cover.

Tab. no. 9 Faults

Image	Sensor	Fault description	Boiler response
1	B2	Exceeding of safety temperature (max. boiler value)	Boiler shut-down. The pumps are still working. The three-way valve opens and water is withdrawn into the heating system.
2	B5	Exceeding of fuel feeder temperature	Fuel feed according to the set algorithm so that the burning fuel is returned into the burner.
3	Motor heating protection	Exceeding of fuel feeder motor winding temperature	Boiler shut-down. The primary pump is still working. After the winding has cooled down and the heating protection has re-switched put the boiler into operation.
4	B2	Extinction of boiler. The outlet temperature in a given time interval does not grow. The absence of fuel, feeder blockage etc. might be the reasons.	Boiler shut-down. The protection against fuel fire penetration is active
7	B3	Overheating of warm water in HW reservoir	End of HW heating. Three-way valve turns to HC.
8	B1	HC overheating	HC heating and HC pump shut-down.
9	-	Time validity. If absence of voltage on regulator is longer than approx. 3 days counting of time (date, time) will stop. It is necessary to set current time a date.	Boiler heats to the set temperature in the first period on Monday.

FAULT MESSAGES IN CASE OF SHORT CIRCUIT OR SENSORS DISCONNECTION			
10	B1	Heating branch temperature	HC heating shut-down
11	B2	Boiler outlet temperature	Boiler operation shut-down. The protection against fuel fire penetration is active. Primary pump is active.
12	B3	HW reservoir temperature	HW heating shut-down
13	B5	Feeder reservoir temperature	Boiler operation shut-down.
14	B9	Outside temperature	Boiler operation to the fixed temperature.
15	A6	Room device	Boiler heats to the latest desired temperature.

6.4 Service board

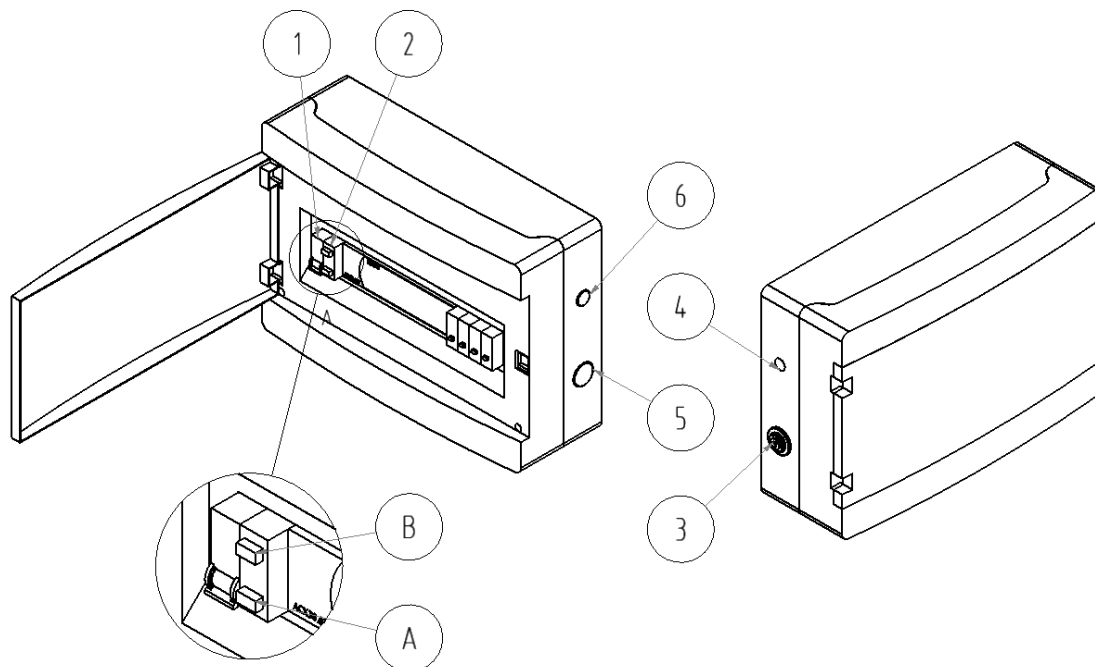

- 1 – Circuit breaker (circuit breaker B16 1P)
- 2 – Two-button station (note: green and blue backlighting)
- 3 – Cable gland ABB (thermoplastic)
- 4 – Safety thermostat signal lamp (orange)
- 5 – Dummy plug 28,0 (colour: white)
- 6 – Dummy plug 14,3 (colour: white)

- A – Two-button station backlighting green –feeder activation when making fire
- B – Two-button station backlighting blue – ventilator activation when making fire

Fig. no. 26 Service board

6.5 Control activity before start

Only the contractual service organization qualified for such type of activity is allowed to put boiler into operation.

Following checks must be carried out before putting the boiler into operation:

a) Filling the heating system with water

Water for filling the boiler and heating system must be clear and colourless, with no suspended matters, oil and chemically aggressive substances. Its hardness must correspond to ČSN 07 7401 and it is necessary to treat water in case its hardness is unsatisfactory. Even the multiple heating of water with a

higher hardness does not prevent the salts from precipitation on the walls of the boiler drum. The precipitation of 1 mm of calcite in a given place reduces the heat transfer from metal to water by 10 %. Heating systems with an open expansion tank allow the direct contact between the heating water and atmosphere. During the heating season the water expanding in the tank absorbs oxygen which increases its corrosive effects and at the same time a considerable volume of water evaporates. Only water treated according to ČSN 07 7401 can be used for refilling.

The heating system must be thoroughly flushed in order to wash out all impurities. During the heating season it is necessary to keep a constant volume of water in the heating system. Refilling the heating system with water must be done carefully in order to prevent air sucking into the system. Water in boiler and heating system must never be discharged or taken for use with the exception of exigencies such as the repairs etc. By water discharging and new water filling the risk of corrosion and scale formation is increased.

If it is necessary to refill water in heating system we only refill the cooled down boiler in order to prevent the steel basement and cast iron heat exchanger from damage.

b) heating system tightness

c) connection to the chimney - it must be approved by a chimney-sweepers' company

d) burner tightness

Connect the equipment to the mains (insert the plug into socket). Put the main switch (circuit breaker) in the service box into the 1 position. By starting the ventilator (by pressing the blue button) in the service box the burner tightness is checked. All air must flow into the combustion space of retort and cast iron grate. The check must be focused on bearing surfaces:

- of ventilator to the flange
- round the burner cleaning hole
- of the cast iron grate with burner. In case a leakage appears the grate must be removed, the old boiler mastic must be removed from bearing surfaces and an adequate quantity of new mastic must be applied to them; then the grate is remounted into burner. *(Note: In front view to boiler the grate trimming must always be to the rear wall.)*

Repeat the check.

By pressing the blue button again the ventilator is switched off. If you do not switch off the ventilator it will be switched off automatically after 15 minutes (unless there is some requirement from QAA 88 device).

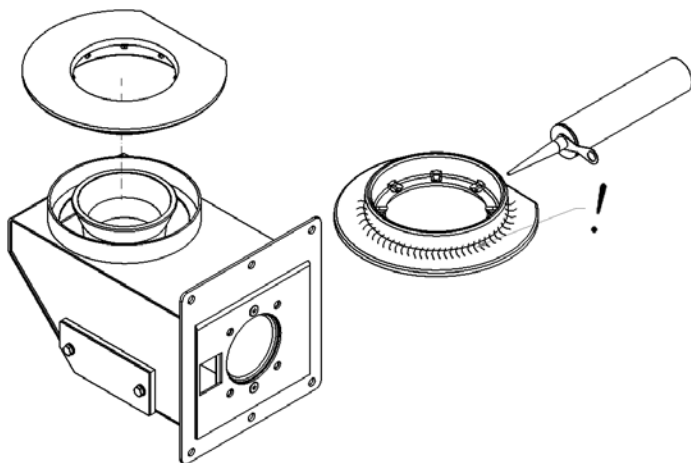

Apply boiler mastic to the point marked with caterpillar and put the grate on the retort with mixer. It is necessary to ensure the tightness between the burner and grate.

e) connection to the mains

The boiler is connected through a movable lead by means of a plug into the standardized socket 230 V/50 Hz/10 A. Protection against electric shock must be ensured according to ČSN 33 2000-4-41.

f) draught regulator in the automatic regime must be taken out of service

g) open the water inlet into valve BVTs or TS 130 or STS 20

h) check the opening of chimney flap

The installation and heating test completion must be recorded in the „Guarantee certificate“.

6.6 Setting of parameters before the equipment start-up

Parameters necessary for equipment start-up

Before you make a fire you must set following parameters:

Parameter	Description	Units	Set by the manufacturer
P 20	Fuel type		1
P 238	Year		-
P 239	Date		-
P 240	Time		-

These parameters are necessary for equipment start-up and other parameters can be modified as need may be or after the discussion with the technician.

Setting P 238 – 240 parameters is important for the boiler operation in time regimes. If the supply outage lasts longer than approx. 7 days (it depends on the number of regulator operating hours) set current time a date after the supply restoration.

Note:

We recommend checking the time periods for warm water and heating circuit (see table no. 7 and 8). These parameters can be modified by customer as need may bet. Three time periods can be used.

Parameters modification according to the type of heated building

Parameter	Description	Units	Set by the manufacturer
P 80	Building constant	[h]	10
P 86	Heating system		3

In case HW heating is not used set 0 at P 42 parameter. HW heating will be ignored also in case of connected HW sensor. HW sensor fault will not be signalled.

6.7 Boiler putting into operation

1. Making fire in the boiler.

- Connect the equipment to the mains (insert plug into the socket).
- Put the main switch (circuit breaker) in the service box into the 1 position.
- Check whether QAA 88 device is switched off or switch it off by means of OK key; cursor will move into ON/OFF position. QAA 88 device will be switched off.



- Check setting of parameters see chap. 6.6.
- On the pressure gauge check volume of water in heating system.
- Open the stop valves between boiler and heating system.
- Check the pumps functionality (mechanical spinning, then according to parameters: primary pump (P 50, P 51), pump HC (P 55, P 56), pump HW (P 59, P 60)).
- Clean the burner and ash-pan drawer (in case fire isn't made for the first time). Ash-pan door during fire making and boiler operation must be permanently closed.
- Fill the fuel reservoir with specified fuel and then close the reservoir carefully in order to prevent possible air intake into the burner through the feeder.
- By pressing the green button on the service box put the fuel feeder for fuel feed to burner manually into operation. Fuel must be supplied approx. 2 cm under the edge of the cast iron grate. In case we start with an empty fuel feeder the fuel transport to burner will last 6 – 6,5 min. After 6 minutes the feed screw is automatically switched off and if required then by pressing the green button again it is put into operation. By pressing the green button again the fuel feeder is switched off.
- Put the kindling e.g. paper, wood chips, PEPO, solid alcohol etc. on the fuel.
- Ignite and let flare up.
- Shovel a small volume of specified fuel to the burning kindling.
- Close the door and switch on the ventilator by means of blue button in the service box (the ventilator run is signalled by flickering cursor above the ventilator symbol). Through the door choker the fuel flaring can be checked. As necessary the ventilator can be switched off by pressing the blue button

and if it be to the contrary the ventilator is automatically switched off after 15 minutes. When making fire the ventilator is set to 50 % nominal ventilator output (set by the manufacturer). In case the fuel has changed for wood pellets this output must be set to 20 % (parameter P 22).

- When making fire the height of fuel must be kept approx. 2 cm under the edge of the cast iron grate.
- If after 15 minutes the fuel is sufficiently flaring switch on QAA 88 device by pressing the right-hand key ESC and cursor will move into Auto position

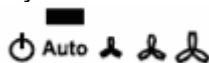

- If after 15 minutes the fuel does not flare up sufficiently switch on the ventilator again for the necessary period of time and then switch on QAA 88 device by the right-hand key ESC; the cursor will move into Auto position
- Now the boiler is in the automatic regime.
- **WARNING! If before the QAA 88 device turning–on the ventilator is still switched on in the manual regime, (display of QAA 88 device is flickering i.e. 15 minutes have not elapsed since pressing the blue button) switch off the ventilator by means of blue button and only then switch on the QAA 88 device.**

2. Check the boiler tightness again.
3. Carry out the heat test according to relevant standards (see the Guarantee certificate).
4. Make the user acquainted with boiler attendance.
5. Make a record in the Guarantee certificate.

The boiler only can be put into operation by a professional installation company qualified for conducting this activity.

6.8 Important warnings

- The boiler must not be used for other purposes than those it is designed for.
- The boiler only can be operated by adults who are acquainted with this service manual. It is forbidden to leave unattended children in the vicinity of operating boilers.
- The boiler is not destined for use by persons (including children) whose physical, sensory or mental disability or lack of experience and knowledge prevent them from a safe use of the appliance if they are not supervised or were not instructed regarding the use of the appliance by a person responsible for their safety.
- Children should be watched to make sure that they do not play with the appliance.
- If there occurs the danger of flammable vapours or gases development and their penetration into boiler room or during the works that are accompanied by temporary danger of fire or explosion (gluing the flooring materials, painting with combustible paints etc.) the boiler must be put out of service prior to the start of such works
- When transporting fuel into combustion chamber before making a fire the volume of fuel in retort must be checked visually and not by putting hands into fireplace. There is a danger of injury caused by rotating worm shaft.
- It is forbidden to use flammable liquids in making fire in VIADRUS HERCULES DUO boiler.
- Observation of flame is possible by opening the choker of ash-pan door (manual operation). Keep in mind that this situation is associated with an increased danger of sparks dispersion in the boiler room. Immediately after the visual check of flame the choker must be properly closed.
- During the VIADRUS HERCULES DUO boiler operation it is forbidden to overheat it in any way.
- It is forbidden to put any things made of flammable materials on the boiler or within the distance less than the safe distance.
- When removing the ash from boiler there must not be found any flammable substances within 1500 mm from the boiler. The ash must be collected in a non-flammable ashbin with a cover. Use the protection aids.
- After the end of heating season the boiler including the smoke flue must be properly cleaned. The boiler room must be kept clean and dry.
- It is forbidden to interfere with construction and electric installation of boiler.
- In case the two-way safety device has responded to refill with water not conforming to ČSN 07 7401 it is necessary to treat the water in the system so that it again conforms to this standard.
- The safety valve of max. 250 kPa overpressure must be installed in the system and its dimensions must correspond to boiler nominal output. In case of further questions please contact our contractual installation firms and service organizations.
- A poor fuel quality can markedly negatively affect the boiler output and emission parameters.

6.9 Maintenance

- 1) It is necessary to be mindful of timely fuel refilling. If only a small volume of fuel is left in the reservoir it must be immediately refilled. **Mind the proper closing of the fuel reservoir cover!**
- 2) If the boiler is correctly adjusted the fuel is burnt out in case it has reached the edges of the combustion grate. The ash and slag fall into do ash-pan drawer. At an average boiler output the ash-pan drawer must be emptied every other day (protective gloves must be used). Sometimes a piece of slag can get stuck between the edge of the combustion grate and boiler wall. Then it must be removed by means of a poker.
- 3) In case of non-stop boiler operation the boiler drum convective surface should be cleaned once a month (the heat exchange surfaces are covered with deposits thus both the heat transfer and boiler efficiency can be adversely affected). **When combusting the pellets the fuel is agglomerated in the retort therefore this agglomerate must be mechanically removed once a month otherwise the feed screw stops moving.** Also the mixer must be cleaned from time to time because when covered with deposits the combustion air flow to the burner gets worse. At least one hour before cleaning the boiler must be put out of service.
- 4) Then the geared motor and ventilator have to be **externally** cleaned from time to time. **(The operator must not remove the cover from the ventilator or interfere with these units. Only the qualified service worker can perform these operations.)** A dry brush must be used for cleaning. At this time boiler must be disconnected from the electricity supply.
- 5) If pieces of stone, metal or wood appear in the fuel the feed screw might get blocked In this situation accompanied by engine overheating followed by its stopping the boiler must be switched off and the obstacle removed.
WARNING: before performing this operation you must make certain that the boiler is disconnected from the electricity supply (the plug pulled out of the socket).
- 6) Because a slight overpressure is developed in the burner during the ventilator operation it is necessary to mind the perfect boiler tightness (door of the fireplace, door of the ash-pan, burner cleaning hole, fuel reservoir cover etc.). The fuel reservoir tightness is given by the proper closing of its cover by means of rotary closure and undamaged rubber sealing of the bearing surfaces.
- 7) In case of emergency (electricity outage lasting longer etc.) and fuel fire penetration to the fuel reservoir the valve BVTS (TS 130, STS20) responds due to the increased temperature and fuel is extinguished.
- 8) Regularly once a month clean the boiler walls inside the fireplace, boiler smoke draughts and smoke adapter (by means of a brush at cooled down boiler the temperature of which does not exceed 40 °C). The cleaning cover in the lower part of the smoke adapter serves for ash removal. When dismantling the cleaning cover the screw of securing swivel must be loosened to avoid its damage. After the smoke adapter has been cleaned we mount back the cleaning cover whereas we are particular about the tightness between the cleaning cover and smoke adapter.

6.10 HMI (ACX84.910/ALG) service unit for Saphir regulator operation

HMI (ACX84.910/ALG) service unit for Saphir regulator operation in combination with QAA 88 device can be used as display of boiler. This unit has a separate service manual.

The preservation of left segment of S1 switch in off position is the condition of HMI unit connection.

7. Manual operation

7.1 Control, regulation and security elements

The volume of flue gas from boiler to chimney is regulated by the smoke flap of the smoke adapter. It is operated by a handle with draw rod in the upper left-hand part of boiler next to the stoking door.

The combustion air inlet under the boiler grate is regulated by the choker of ash-pan door. The choker is operated by the draught regulator or manually by choker setscrew.

The rosette of stoking door serves for secondary air inlet into combustion space.

The thermometer and pressure gauge must be mounted in the heating system in order to measure the return water temperature and water pressure. Thermometer type 63 for rear connection made by Regulus and pressure gauge type 50 (400 kPa) for rear connection also made by Regulus are recommended.

7.1.1 Equipment for superfluous heat withdrawal

The after- cooling loop or two-way safety valve DBV 1 - 02 serve for superfluous heat withdrawal in case the water temperature in boiler has exceeded 95 °C. The after- cooling loop is connected to boiler flanges according to Fig. no. 27(two-way safety valve according to Fig. no. 30).

In case of boiler overheating (outlet temperature is higher than 95 °C) the thermostatic valve switches (starts to operate) and the superfluous heat is withdrawn via the after cooling loop.

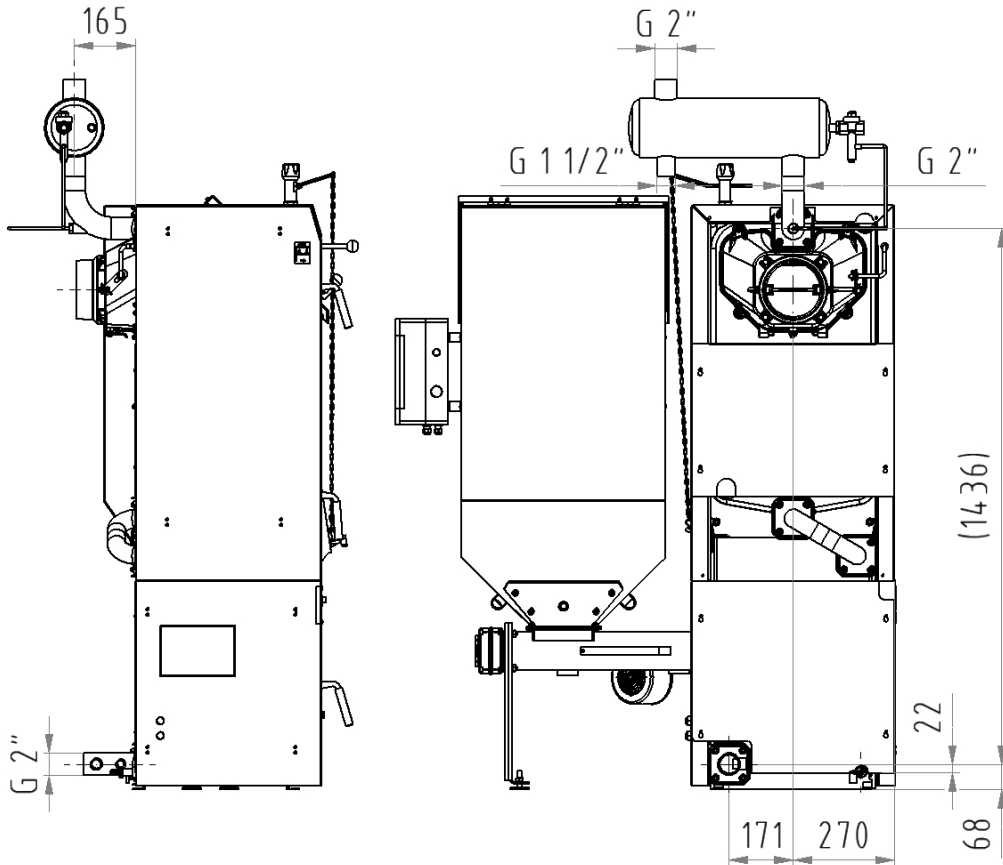
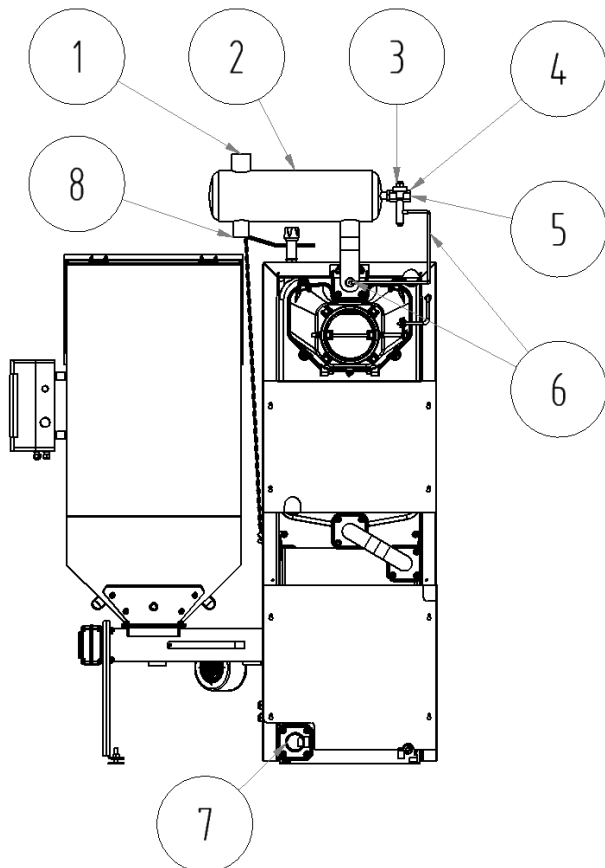
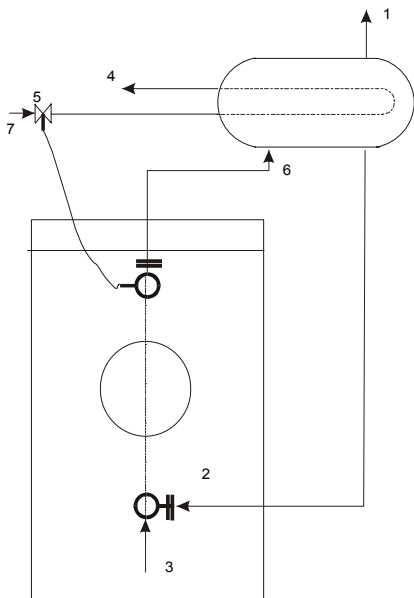

Fig. no. 27 Boiler with after- cooling loop – connecting dimensions



- 1 Heating water outlet into system 2"
- 2 After-cooling loop
- 3 Thermostatic valve BVTs (STS 20) TV 95 °C
- 4 Cooling water inlet 1/2 "
- 5 Cooling water outlet 1/2"
- 6 Thermostatic valve sensor
- 7 Return water inlet into boiler from system 2"
- 8 Return water inlet from after-cooling loop 1 1/2"

Fig. no. 28 Boiler with after- cooling loop



- 1 – Heating water outlet into system 2”
- 2 – Return water inlet from after-cooling loop 1 1/2 “
- 3 – Return water inlet into boiler from system 2”
- 4 – Cooling water outlet
- 5 – Thermostatic valve BVTS (STS 20)
- 6 – Heating water outlet from boiler 2 “
- 7 – Cooling water inlet

Fig. no. 29 Hydraulic diagram of after- cooling loop connection

In case the system is equipped with two-way safety valve DBV 1 - 02 and the boiler becomes overheated (outlet water temperature is higher than 95 °C) the two-way safety valve circuit makes the cold water circuit until the temperature has dropped below the limit value. At this moment the draining cooling equipment and cold water inlet to refill the boiler are closed simultaneously.

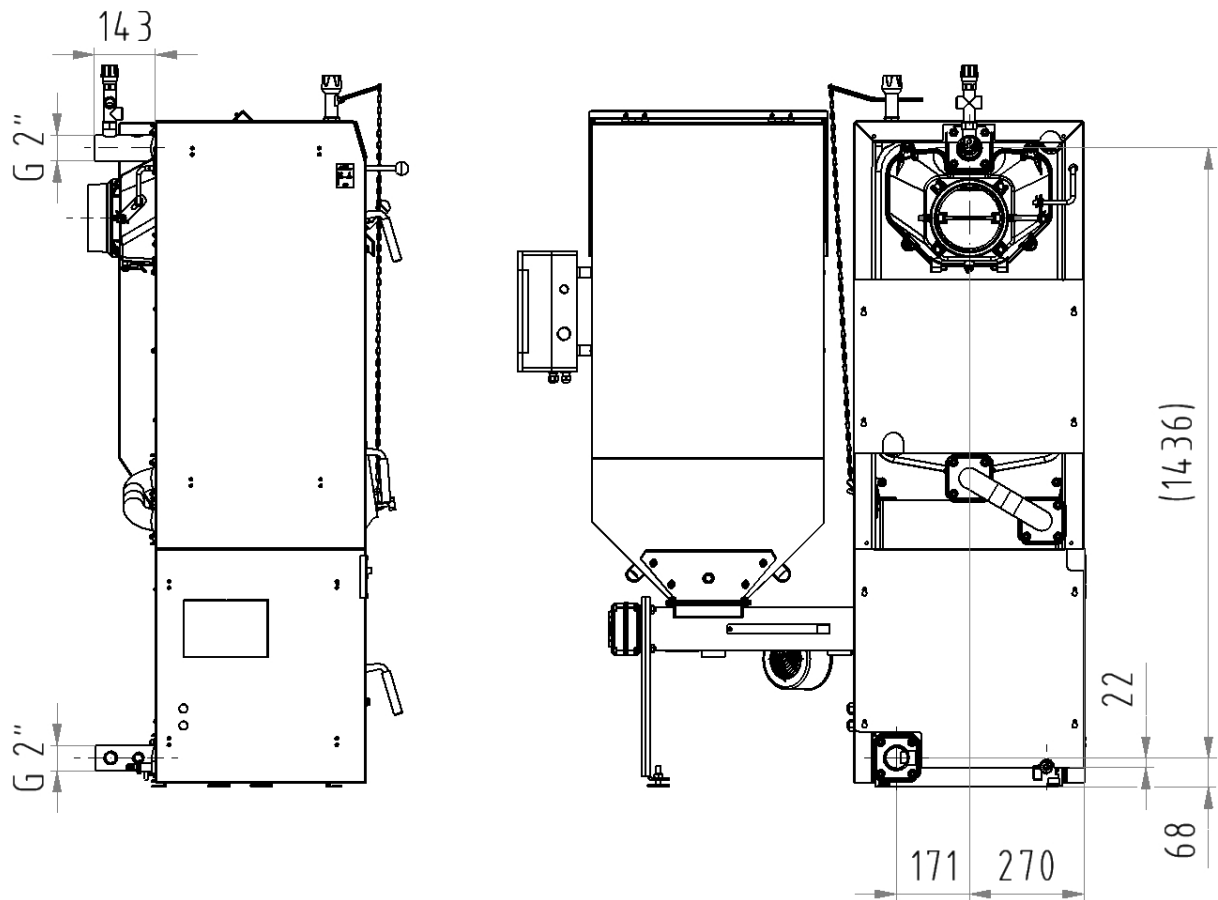

Fig. no. 30 Boiler with valve DBV 1 – 02 – connecting dimensions

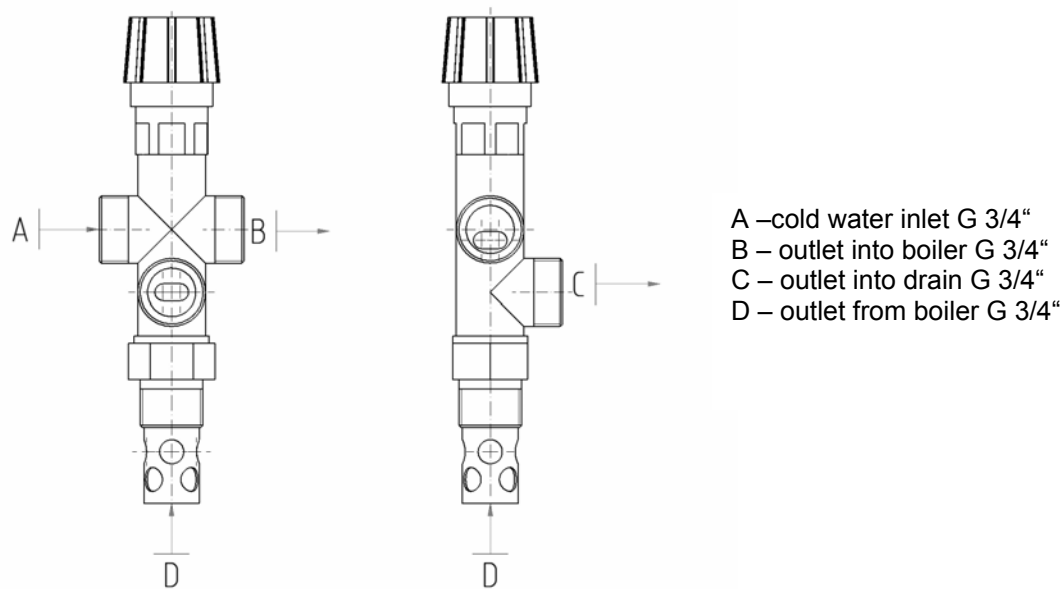
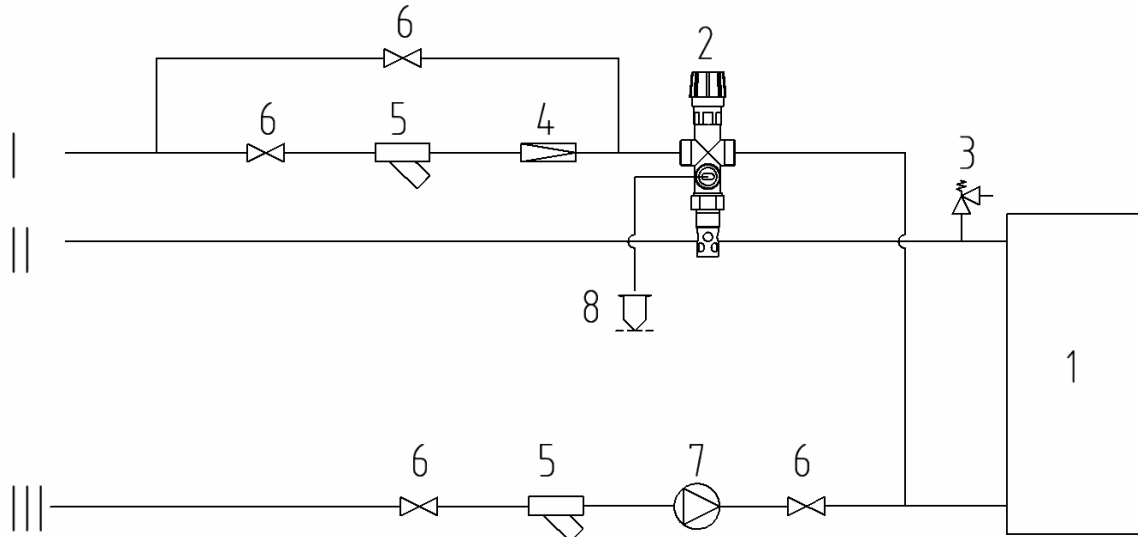

Fig. no. 31 Two-way safety valve DVB 1 - 02



- 1 – Boiler
- 2 – Two-way safety valve DBV 1 - 02
- 3 – Safety valve
- 4 – Reduction valve

- 5 – Filter
- 6 – Ball tap
- 7 – Pump
- 8 – Superfluous heat withdrawal

- I – Cold water inlet
- II – Heating water outlet
- III – Return water inlet

Fig. no. 32 Recommended diagram of two-way safety valve connection DVB 1 - 02

Technical data of two-way safety valve DBV 1 - 02 (made by Regulus)

Opening temperature (limit): 100 °C (+0° - 5 °C)
 Maximum temperature: 120 °C
 Maximum pressure on boiler side: 250 kPa
 Maximum pressure on water side: 600 kPa
 Nominal flow at Δp 100 kPa: 1,9 m³/h

Application

Two-way safety valve DBV 1 - 02 is designed for central heating boilers protection against overheating. In the valve body there is the drain and refill valve controlled by thermostatic element. Once the limit temperature has been achieved the drain and refill valves open simultaneously it means cold water flows into boiler and at the same time hot water is drained from the boiler. Once the temperature has dropped below the limit value the drain and refill valve are closed simultaneously.

ATTENTION! It does not substitute for the safety valve.

In case the two-way safety device has responded to refill with water not conforming to ČSN 07 7401 it is necessary to treat the water in the system so that it again conforms to this standard

Installation

Only the professionally qualified person is allowed to carry out the installation. It is always necessary to observe the conditions specified for two-way safety valve installation and follow the flow directions indicated on the valve body in order to guarantee its proper function. The safety valve is always installed in the boiler outlet piping or directly on the boiler in its upper part where the heated water leaves boiler and flows into heating system. When the valve is installed it must be checked whether by using ¾" sleeve that can be both in piping and on the boiler it is ensured that the valve thermostatic element will be fully immersed after the installation. After the mounting in the sleeve the downpipe is connected at the point „C“ (Fig. no. 31) and hot water from boiler will flow into drain through this downpipe. The cooling water inlet is connected at the point “A” according to (Fig. no. 32) and this water will ensure cooling of boiler after the valve has been put into service. Filter for catching the mechanical impurities must be mounted at cooling water inlet. The piping that according to Fig. no. 32 is led into return pipe of the heating system near the boiler is connected at the point “B”.

Regular maintenance

Turn the safety valve head once a year in order to remove possible impurities deposited in the valve. Clean the filter at cooling water inlet.

Important

The flows cannot be reversed therefore the filling and draining indicated on the valve must be observed.

In case of using an open expansion tank the safety device against overheating needn't be used.

Every heat source in an open heating system must be connected with an open expansion tank positioned at the highest point of the heating system. The expansion tanks must be dimensioned in the way making sure that their capacity is sufficient for holding varying water volumes caused by heating and cooling.

The open expansion tanks must be equipped with not closable breather and overflow pipes. The overflow pipe must be designed in such a way that it will safely drain the maximum flow volume entering the system. This can be reached by dimensioning the overflow pipes by one DN higher than the filling pipe. The expansion tanks and their connecting pipes must be designed and positioned at the places where they are reliably prevented from freezing

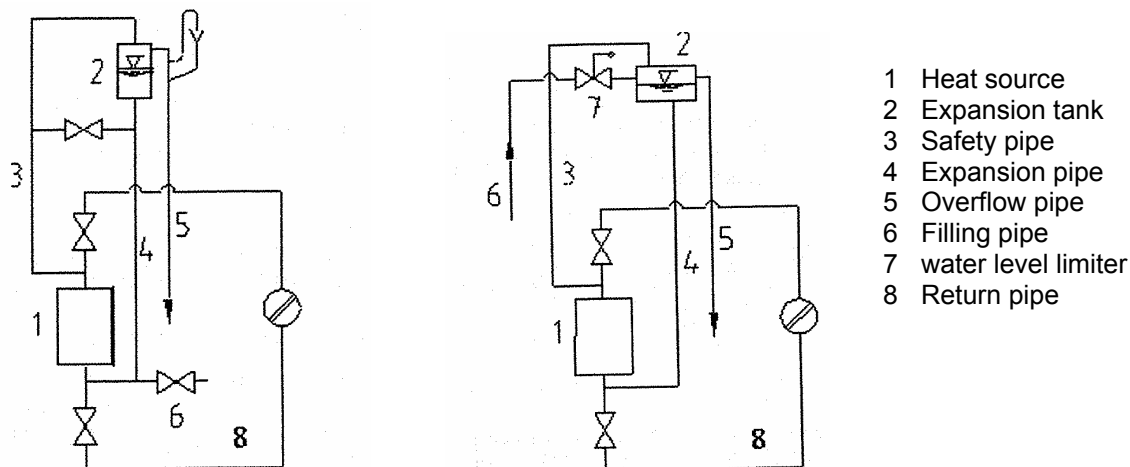

Fig. no. 33 Examples of open expansion tanks connection

7.2 Control activity before start

Boiler only can be put into service by a contractual service organization qualified for this activity performance.

Following checks must be carried out before putting the boiler into service:

- Filling the heating system with water (pressure gauge check) and tightness of the system;
- connection to the chimney - **it must be approved by a chimney-sweepers' company(chimney revision);**
- draught regulator and thermostatic valve functionality;

- d) **position the ash-pan on the insulation put on the retort (otherwise the ember could fall into burner with mixer and consequently fuel in fuel feeder and reservoir could catch fire);**
- e) the fuel reservoir cover must be left closed.

7.3 Setting and description of Saphir regulator – Manual operation

The Saphir regulator is used also in the manual operation. In QAA 88 device in P 20 parameter – Fuel type select the value 4 (Manual operation) and adjust the boiler to manual operation (see chap. 7.2 letter c, d). The functions of individual boiler components are predefined in this type of operation. These functions differ from the automatic regime. Ventilator and fuel feeder are not active. The space is not influenced by QAA 88 device. When setting the temperature on the draught regulator mind the necessary boiler temperature increase compared with the desired HW temperature

7.3.1 Pump heating circuit

HW preparation

HW preparation runs according to set time regimes and desired HW temperature. Once the desired HW temperature has been reached the slowing-down regime is active. If the boiler temperature after HW preparation completion is higher than desired HW temperature plus 5 °C there is active the boiler slowing-down into HW circuit and it is followed by HW three-way valve slowing-down (parameter P 67). If the boiler temperature after HW preparation completion is not higher than desired HW temperature plus 5 °C the boiler slowing-down from boiler is not active, but HW three-way valve slowing-down starts immediately. If after HW three-way valve slowing-down the temperature in boiler is left higher than the temperature set for primary pump start (parameter P 53) the heat will be withdrawn to HC. Primary pump switch-off is according to P 53 parameter minus 5 °C.

In case HC needn't be heated (e.g. in summer) adjust the volume of fuel in boiler to heating of water heater.

Heating circuit

The primary pump will be switched according to P 53 parameter. The draught regulator serves for boiler output regulation.

7.3.2 Mixing heating circuit

HW preparation

HW preparation runs according to set time regimes and desired HW temperature (HW thermostat). If the boiler temperature is at least by 3 °C lower against the desired HW temperature plus the increase (set by manufacturer to 15 °C) HW pump will not work. If this limitation is active HC pump will not work either. After the desired HW temperature has been reached the HW pump slowing-down is active (parameter P 61).

In case HC needn't be heated (e.g. in summer) adjust the volume of fuel in boiler to heating of water heater or reduce the primary pump slowing-down to approx. 2 minutes (parameter P 52).

Heating circuit

Three-way mixing valve automatically opens into the heating circuit by selecting the fuel type – value 4 (manual operation). The primary pump is switched on by P 53 parameter and switched off once the water temperature has dropped by 5 °C against P 53 parameter. Heating circuit pump is switched on and switched off in the same way as the primary pump

7.4 Boiler putting into operation

1. Make a fire in boiler.
 - Check the volume of water in the heating system on the pressure gauge.
 - Open the stop valves between the boiler and heating system.
 - Clean the grate, ash-pan, smoke channels and boiler walls.
 - Put kindling and wood through the ash-pan door on the cleaned grate all over the boiler depth.
 - Put the smoke flap in the smoke adapter into the open position and close the stoking door.
 - Ignite the kindling through open ash-pan door.
 - Close the ash-pan door and open the choker in full.
 - Put a thinner layer of basic fuel on the flaring wood.
 - Once it is flaring too add the fuel up to the lower edge of stoking door and level the fuel into a uniform layer all over the boiler depth.

- As soon as the burning fuel becomes a dark red glow slightly open the rosettes on stoking door for secondary air inlet.
 - In case of burning wood and hard coal the stoking door rosette must be open.
2. Bring the boiler to the necessary operating temperature: 80 °C is the recommended outlet water temperature.
 3. Adjust the draught regulator including the length of chain (according to enclosed manual for draught regulator).
 4. Check the functionality of safety device against overheating (after-cooling loop or two-way safety valve DBV 1 - 02).
 5. Operate the boiler in the operating condition according to relevant standards.
 6. Check again the boiler tightness.
 7. Make the user acquainted with boiler attendance.
 8. Make record in the guarantee certificate.

7.5 Boiler attendance by user

Fuel

COKE

The coke of 24 – 60 mm granularity is the most suitable fuel.

HARD COAL

The hard coal of 24 – 60 mm granularity is the most suitable fuel.

WOOD

Wood moisture of 20% must be kept in order to achieve the boiler nominal efficiency.

Fuel must be stored under cover.

The grate cleaning is done in such a way that no glowing fuel falls into the do ash-pan.

Recommended dimensions of wood blocks

Blocks diameter ũ Ø 40 - 100 mm

Blocks length 300 mm

Make a fire

1. Check the volume of water in the heating system on the pressure gauge.
2. Open the stop valves between the boiler and heating system.
3. Clean the grate, ash-pan, smoke channels and boiler walls.
4. Put kindling and wood through the ash-pan door on the cleaned grate all over the boiler depth.
5. Put the smoke flap in the smoke adapter into the open position and close the stoking door.
6. Ignite the kindling through open ash-pan door.
7. Close the ash-pan door and open the choker in full.
8. Put a thinner layer of basic fuel on the flaring wood.
9. Once it is flaring too add the fuel up to the lower edge of stoking door and level the fuel into a uniform layer all over the boiler depth.
10. As soon as the burning fuel becomes a dark red glow slightly open the rosettes on stoking door for secondary air inlet.
11. In case of burning wood and hard coal the stoking door rosette must be open..

Operation

1. As soon as the heating water temperature has been achieved adjust the combustion air inlet. Boiler output is coarsely regulated by changing the chimney draught by means of smoke flap in the smoke adapter. The fine regulation is done by means of choker that regulates the air inlet under the grate either manually or by means of draught regulator. The draught regulator is to be adjusted in such a way that the choker in ash-pan door is closed at the moment the desired heating water temperature has been achieved.
2. Depending on the heat necessity and burning intensity the boiler must be refilled with fuel during its operation. Stoke in such a way that the fuel layer is equally high all over the boiler depth.
3. When using coke, hard coal and wood the secondary air inlet in stoking door must be left ajar during the whole time of gases and flames development from freshly stoked fuel.
4. When passing to the night attenuated operation clean the grate, let properly flare the freshly stoked fuel and then attenuate the boiler output by choking the chimney draught by means of smoke flap in the smoke adapter and closing the secondary air inlet in the stoking door. The degree of smoke flap and

secondary air opening must be tested, but always mind that flue gas does not escape into the boiler-room. In this case unhang the chain of draught regulator (close the choker completely).

5. For fire renewal in the morning we open the smoke flap and secondary air inlet on stoking door and we poke the grate after opening the ash-pan door.
6. Ash-pan door must be permanently closed during the boiler operation.
7. As necessary we empty the ash-pan (by using the gloves)
8. In case the stop valves are used then it is necessary to install the safety valve between the boiler and stop valve.
9. The filter should be cleaned after the heat test and then before the heating season starts.

7.6 Important warnings

- **The boiler only can be used for the purposes it is designed for.**
- **The boiler only can be operated by adults who are acquainted with this service manual. It is forbidden to leave unattended children in the vicinity of operating boilers. The interferences with boiler construction that could endanger the health of operators or inmates are forbidden.**
- **The boiler is not destined for use by persons (including children) whose physical, sensory or mental disability or lack of experience and knowledge prevent them from a safe use of the appliance if they are not supervised or were not instructed regarding the use of the appliance by a person responsible for their safety.**
- **Children should be watched to make sure that they do not play with the appliance.**
- **If there occurs the danger of flammable vapours or gases development and their penetration into boiler room or during the works that are accompanied by temporary danger of fire or explosion (gluing the flooring materials, painting with combustible paints etc.) the boiler must be put out of service prior to the start of such works**
- **It is forbidden to use flammable liquids in making fire in VIADRUS HERCULES DUO boiler.**
- **it is forbidden to overheat boiler during its operation.**
- **It is forbidden to put any things made of flammable materials on the boiler or within the distance less than the safe distance.**
- **When removing the ash from VIADRUS HERCULES DUO boiler there must not be found any flammable substances within 1500 mm from the boiler. Use the protection aids.**
- **In case the boiler is operated at the temperature lower than 60°C the boiler drum can grow damp and it is exposed to so called low-temperature corrosion which reduces the boiler drum lifetime.**
- **After the end of heating season the boiler including the smoke flue must be properly cleaned. Lubricate all swivel pins, smoke flap mechanism and other movable components on the boiler with the graphite grease. The boiler room must be kept clean and dry.**
- **Possible signs of corrosion do not mean any fault and they do not influence the boiler function.**
- **In case the two-way safety device has responded to refill with water not conforming to ČSN 07 7401 it is necessary to treat the water in the system so that it again conforms to this standard.**
- **The safety valve of max. 250 kPa overpressure must be installed in the system and its dimensions must correspond to boiler nominal output. In case of further questions please contact our contractual installation firms and service organizations.**
- **Observation of flame is possible by a slight opening of stoking door. First of all we close the choker of ash-pan door, then we slightly open the stoking door for approx. 10 sec and then we can open the door in full. Keep in mind that this situation is associated with an increased danger of sparks dispersion in the boiler room. Immediately after the visual check of flame the door must be closed and choker opened.**
- **A poor fuel quality can markedly negatively affect the boiler output and emission parameters**

7.7 Maintenance

1. During the boiler operation remove the ash from the ash-pan several times a day depending on the type of used fuel because the full ash-pan prevents the proper distribution of combustion air under the fuel and can cause an uneven fire penetration through the fuel on the grate. All remnants in the fireplace especially the slag must be removed before you make a new fire or "revive" the fire in the morning. The ash must be collected in ashbins made of inflammable materials with cover. **Use the protection aids at work** and be mindful of your personal safety.
2. The walls inside the boiler, smoke draughts and smoke adapter must be cleaned regularly once a month (by means of a brush and after the boiler has cooled down and its temperature does not exceed 40 °C) when burning coke, hard coal or wood. The cleaning cover in the lower part serves for ash removal from the smoke adapter. When dismantling the cleaning cover the screw of securing swivel must be loosened

- to avoid its damage. After the smoke adapter has been cleaned we re-mount the cleaning cover whereas we are particular about the tightness between the cleaning cover and smoke adapter.
3. If in case of using the fuels with a higher gas evolution the tar is deposited on the walls of combustion space we remove it by using the scraper or by burning-out by means of dry hard wood (or coke) and bringing the boiler to max. operating temperature.
 4. After the end of heating season the swivel pins of smoke flap and all doors must be serviced.

8. Instructions for product disposal after expiration of its lifetime

ŽDB GROUP a. s., member of KKCG Industry is a contract partner of EKO-KOM a. s. with client number EK-F00060715. The packages conform to EN 13427

The packages are recommended to be disposed of in following way:

- plastic foil, cardboard package, use the salvage service
- metal strapping band, use the salvage service
- wood base, is destined for a single use and no longer can be used as the product. Its disposal is subject to law 477/ 2001 Coll. and 185/2001 Coll. as amended.

Because the product is constructed of common metal materials the individual components are recommended to be disposed of in following way:

- heat exchanger (grey cast iron), use the salvage service
- tube distribution, shell, use the salvage service
- other metal components, use the salvage service
- insulation material ROTAFLEX, through the company engaged in waste collection and disposal

In case the product has lost its manufacture qualities then so called reverse product withdrawal (if it is introduced) can be used; if the originator declares that it regards the waste it will be handled according to the legislation valid in relevant country.

9. Guarantee and liability for defects

ŽDB GROUP a.s., member of KKCG Industry, VIADRUS plant provides the guarantee:

- for boilers for 24 months after the product has been put into service, but maximum 30 months after the date of dispatch from the production plant
- for cast iron boiler drum for 5 years after the date of dispatch from the production plant

In case of a complaint regarding the shell the customer is obliged to submit the packaging label of the boiler shell. It is put on cardboard in which the shell is dispatched.

The user is obliged to entrust a professional installation company with putting the boiler into service and a professional contractual service accredited by ŽDB GROUP a.s., member of KKCG Industry, VIADRUS plant with and faults removal, otherwise the guarantee does not apply to the proper function of boiler. „The **VIADRUS HERCULES DUO** boiler quality and completeness certificate “ serves for infilling as the „Guarantee certificate“.

The user is obliged to carry out a regular maintenance on the boiler.

Every fault must be announced in writing or by telephone immediately after it has been detected.

In case the above instructions are not observed the guarantees provided by the manufacturer are not admitted.

The manufacturer reserves the right to make changes within the product innovation that needn't be contained in this manual.

The guarantee does not apply to:

- **faults caused by wrong mounting and improper product attendance and faults caused by improper maintenance see chap. 7**
- **product damage caused by transport or other mechanical damage**
- **faults caused by improper storage**
- **faults and damage caused by failure to observe water quality in heating system see chap. no. 4.1 and 6.5 or by using the anti-freeze mixture**
- **faults caused by instructions specified in this manual non-observance**
- **faults caused by boiler operation with non-specified fuel (see tab. no. 4 and 5)**

Information for customer

Packaging edentification	Assessment reference
PE Plastic sacks, folie, corrugated board, iron and plastic fix line	

Identification od principál materials used. Paper, Polyethylene, iron, wood

Part 1: Summary of assessment

Standard/Report	Assessment requirement	Claim	Note
1.1 Prevention by source reduction		YES	
1.2 Heavy metals and	ensure below maximum permitted levels for components (CR 13695-1:2000)	YES	
1.3 Other noxious/hazardous substances	ensure in compliance with (CR 13695-2:2002, EN 13428:2000)	YES	
2 Reuse	ensure reusability in all terms of the standard for the functional packaging unit (EN 13429:2000)	NO	
3.1 Recovery by material recycling	ensure recyclability in all term sof the standard for the functional packaging unit (EN 13430:2000)	YES	
3.2 Recovery in the form of energy	ensure that calorific gain is achievable for the functional packaging unit (EN 13431:2000)	YES	Iron - NO
3.3 Recovery by composting	ensure compost ability in all terms of the standard for the functional packaging unit (EN 13432:2000)	NO	

NOTE Conformity with EN 13427 requires affirmative responses to sections 1.1; 1.2; 1.3 and to at least one of 3.1; 3.2; 3.3. In addition, where a claim of reuse is made section 2 should also record affirmative responses.

Part 2: Statement of conformity

In the light of the assessment results recorded in part I above, this packaging is claimed to comply with the requirements of EN 13427:2000.

Certificate of warranty and Quality and completeness certificate for VIADRUS HERCULES DUO boiler

Boiler serial number Boiler Output

User(surname,name)

Address(Street,city,zipcode)

Phone/Fax

The boiler corresponds to requirements:

EN 303-5 Boiler for central heating– Part 5: Solid fuel boiler for central heating with manual or automatic feed and nominal heat output maximum 300 kW – Terminology, requirements, testing and marking.

Validity conditions of the guarantee:

- The boiler must be installed according to „Boiler service and installation manual“ by a professional installation company
- The boiler must be put into service according to „Boiler service and installation manual“ by a contractual service organization accredited by the manufacturer
- The faults must be removed by a contractual service organization accredited by the manufacturer

The delivery completeness is guaranteed by the seller.

The unfilled guarantee certificate is not valid.

The guarantee conditions and liability for defects follow chap. no. 9 this manual.

ŽDB GROUP a.s., member of KKCG Industry, VIADRUS plant provides the guarantee:

- for boilers for 24 months after the product has been put into service, but maximum 30 months after the date of dispatch from the production plant
- for cast iron boiler drum for 5 years after the date of dispatch from the production plant

Measured values	Numeric value
Chimney draught (Pa)	
Flue gas temperature (°C)	

The user confirms that:

- the boiler adjusted by the contractual service organization did not prove any fault during the heat test
- he obtained the „Boiler service and installation manual “with properly filled-out Guarantee certificate and Quality certificate
- he was made acquainted with boiler attendance and maintenance

.....
 Manufacture date Manufacturer 's stamp Checked by (signature)

.....
 Date of installation Installation company (stamp, signature) User 's signature

.....
 Date of putting into service Contractual service organization (stamp, signature) User 's signature

Appendix to the guarantee certificate for customer - user

Record of carried out guarantee and after-guarantee repairs and product controls			
Date of record	Carried out activity	Contractual service organization(signature, stamp)	Customer's signature

Certificate of warranty and Quality and completeness certificate for VIADRUS HERCULES DUO boiler

Boiler serial number Boiler Output

User(surname,name)

Address(Street,city,zipcode)

Phone/Fax

The boiler corresponds to requirements:

EN 303-5 Boiler for central heating– Part 5: Solid fuel boiler for central heating with manual or automatic feed and nominal heat output maximum 300 kW – Terminology, requirements, testing and marking.

Validity conditions of the guarantee:

- The boiler must be installed according to „Boiler service and installation manual“ by a professional installation company
- The boiler must be put into service according to „Boiler service and installation manual“ by a contractual service organization accredited by the manufacturer
- The faults must be removed by a contractual service organization accredited by the manufacturer

The delivery completeness is guaranteed by the seller.

The unfilled guarantee certificate is not valid.

The guarantee conditions and liability for defects follow chap. no. 9 this manual.

ŽDB GROUP a.s., member of KKCG Industry, VIADRUS plant provides the guarantee:

- for boilers for 24 months after the product has been put into service, but maximum 30 months after the date of dispatch from the production plant
- for cast iron boiler drum for 5 years after the date of dispatch from the production plant

Measured values	Numeric value
Chimney draught (Pa)	
Flue gas temperature (°C)	

The user confirms that:

- the boiler adjusted by the contractual service organization did not prove any fault during the heat test
- he obtained the „Boiler service and installation manual “with properly filled-out Guarantee certificate and Quality certificate
- he was made acquainted with boiler attendance and maintenance

.....

Manufacture date	Manufacturer’s stamp	Checked by (signature)
.....
Date of installation	Installation company (stamp, signature)	User’s signature
.....
Date of putting into service	Contractual service organization (stamp, signature)	User’s signature

.....

Certificate of warranty and Quality and completeness certificate for VIADRUS HERCULES DUO boiler

Boiler serial number Boiler Output

User(surname,name)

Address(Street,city,zipcode)

Phone/Fax

The boiler corresponds to requirements:

EN 303-5 Boiler for central heating– Part 5: Solid fuel boiler for central heating with manual or automatic feed and nominal heat output maximum 300 kW – Terminology, requirements, testing and marking.

Validity conditions of the guarantee:

- The boiler must be installed according to „Boiler service and installation manual“ by a professional installation company
- The boiler must be put into service according to „Boiler service and installation manual“ by a contractual service organization accredited by the manufacturer
- The faults must be removed by a contractual service organization accredited by the manufacturer

The delivery completeness is guaranteed by the seller.

The unfilled guarantee certificate is not valid.

The guarantee conditions and liability for defects follow chap. no. 9 this manual.

ŽDB GROUP a.s., member of KKCG Industry, VIADRUS plant provides the guarantee:

- for boilers for 24 months after the product has been put into service, but maximum 30 months after the date of dispatch from the production plant
- for cast iron boiler drum for 5 years after the date of dispatch from the production plant

Measured values	Numeric value
Chimney draught (Pa)	
Flue gas temperature (°C)	

The user confirms that:

- the boiler adjusted by the contractual service organization did not prove any fault during the heat test
- he obtained the „Boiler service and installation manual “with properly filled-out Guarantee certificate and Quality certificate
- he was made acquainted with boiler attendance and maintenance

.....

Manufacture date
Manufacturer 's stamp
Checked by (signature)

.....

Date of installation
Installation company
(stamp, signature)
User 's signature

.....

Date of putting into service
Contractual service organization
(stamp, signature)
User 's signature

VIADRUS

ŽDB GROUP a.s. / závod VIADRUS

Bezručova 300 / 735 93 Bohumín / CZ

Tel.: +420 596 083 050 / Fax: +420 596 082 822

www.viadrus.cz / info@viadrus.cz

ŽDB GROUP a.s. / KKCG Industry Group Member