

BUNN®

FMD-4

FMD-5

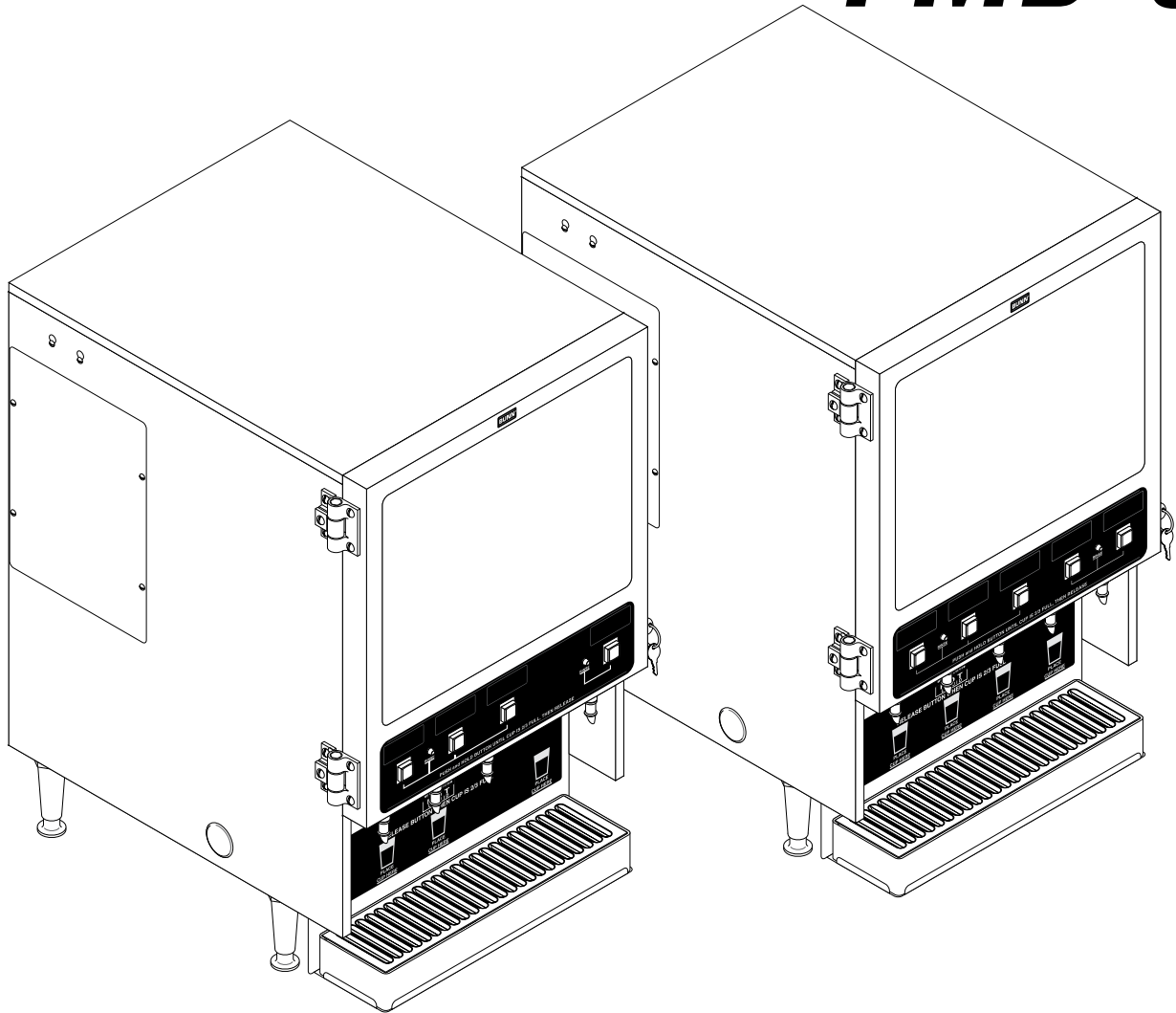

INSTALLATION & OPERATING GUIDE

BUNN-O-MATIC CORPORATION

POST OFFICE BOX 3227

SPRINGFIELD, ILLINOIS 62708-3227

PHONE: (217) 529-6601 FAX: (217) 529-6644

To ensure you have the latest revision of the Operating Manual, or to view the Illustrated Parts Catalog, Programming Manual, or Service Manual, please visit the Bunn-O-Matic website, at www.bunn.com. This is absolutely FREE, and the quickest way to obtain the latest catalog and manual updates. For Technical Service, contact Bunn-O-Matic Corporation at 1-800-286-6070.



BUNN-O-MATIC COMMERCIAL PRODUCT WARRANTY

Bunn-O-Matic Corp. ("BUNN") warrants equipment manufactured by it as follows:

- 1) Airpots, thermal carafes, decanters, GPR servers, iced tea/coffee dispensers, MCP/MCA pod brewers thermal servers and Thermofresh servers (mechanical and digital)- 1 year parts and 1 year labor.
- 2) All other equipment - 2 years parts and 1 year labor plus added warranties as specified below:
 - a) Electronic circuit and/or control boards - parts and labor for 3 years.
 - b) Compressors on refrigeration equipment - 5 years parts and 1 year labor.
 - c) Grinding burrs on coffee grinding equipment to grind coffee to meet original factory screen sieve analysis - parts and labor for 4 years or 40,000 pounds of coffee, whichever comes first.

These warranty periods run from the date of installation BUNN warrants that the equipment manufactured by it will be commercially free of defects in material and workmanship existing at the time of manufacture and appearing within the applicable warranty period. This warranty does not apply to any equipment, component or part that was not manufactured by BUNN or that, in BUNN's judgment, has been affected by misuse, neglect, alteration, improper installation or operation, improper maintenance or repair, non periodic cleaning and descaling, equipment failures related to poor water quality, damage or casualty. In addition, the warranty does not apply to replacement of items subject to normal use including but not limited to user replaceable parts such as seals and gaskets. This warranty is conditioned on the Buyer 1) giving BUNN prompt notice of any claim to be made under this warranty by telephone at (217) 529-6601 or by writing to Post Office Box 3227, Springfield, Illinois 62708-3227; 2) if requested by BUNN, shipping the defective equipment prepaid to an authorized BUNN service location; and 3) receiving prior authorization from BUNN that the defective equipment is under warranty.

THE FOREGOING WARRANTY IS EXCLUSIVE AND IS IN LIEU OF ANY OTHER WARRANTY, WRITTEN OR ORAL, EXPRESS OR IMPLIED, INCLUDING, BUT NOT LIMITED TO, ANY IMPLIED WARRANTY OF EITHER MERCHANTABILITY OR FITNESS FOR A PARTICULAR PURPOSE. The agents, dealers or employees of BUNN are not authorized to make modifications to this warranty or to make additional warranties that are binding on BUNN. Accordingly, statements by such individuals, whether oral or written, do not constitute warranties and should not be relied upon.

If BUNN determines in its sole discretion that the equipment does not conform to the warranty, BUNN, at its exclusive option while the equipment is under warranty, shall either 1) provide at no charge replacement parts and/or labor (during the applicable parts and labor warranty periods specified above) to repair the defective components, provided that this repair is done by a BUNN Authorized Service Representative; or 2) shall replace the equipment or refund the purchase price for the equipment.

THE BUYER'S REMEDY AGAINST BUNN FOR THE BREACH OF ANY OBLIGATION ARISING OUT OF THE SALE OF THIS EQUIPMENT, WHETHER DERIVED FROM WARRANTY OR OTHERWISE, SHALL BE LIMITED, AT BUNN'S SOLE OPTION AS SPECIFIED HEREIN, TO REPAIR, REPLACEMENT OR REFUND.

In no event shall BUNN be liable for any other damage or loss, including, but not limited to, lost profits, lost sales, loss of use of equipment, claims of Buyer's customers, cost of capital, cost of down time, cost of substitute equipment, facilities or services, or any other special, incidental or consequential damages.

392, A Partner You Can Count On, AutoPOD, AXIOM, BrewLOGIC, BrewMETER, Brew Better Not Bitter, BrewWISE, BrewWIZARD, BUNN Espresso, BUNN Family Gourmet, BUNN Gourmet, BUNN Pour-O-Matic, BUNN, BUNN with the stylized red line, BUNNlink, Bunn-OMatic, Bunn-O-Matic, BUNNserve, BUNNSERVE with the stylized wrench design, Cool Froth, DBC, Dr. Brew stylized Dr. design, Dual, Easy Pour, EasyClear, EasyGard, FlavorGard, Gourmet Ice, Gourmet Juice, High Intensity, iMIX, Infusion Series, Intellisteam, My Café, Phase Brew, PowerLogic, Quality Beverage Equipment Worldwide, Respect Earth, Respect Earth with the stylized leaf and coffee cherry design, Safety-Fresh, savemycoffee.com, Scale-Pro, Silver Series, Single, Smart Funnel, Smart Hopper, SmartWAVE, Soft Heat, SplashGard, The Mark of Quality in Beverage Equipment Worldwide, ThermoFresh, Titan, trifacta, Velocity Brew, Air Brew, Air Infusion, Beverage Bar Creator, Beverage Profit Calculator, Brew better, not bitter., BUNNSource, Coffee At Its Best, Cyclonic Heating System, Daypart, Digital Brewer Control, Element, Nothing Brews Like a BUNN, Pouring Profits, Signature Series, Tea At Its Best, The Horizontal Red Line, Ultra are either trademarks or registered trademarks of Bunn-O-Matic Corporation. The commercial trifacta® brewer housing configuration is a trademark of Bunn-O-Matic Corporation.

INTRODUCTION

This equipment dispenses hot beverages or soups on demand from powdered product. It is for indoor use only on a sturdy counter or shelf.

USER NOTICES

Carefully read and follow all notices on the equipment and in this manual. They were written for your protection. All notices are to be kept in good condition. Replace any unreadable or damaged labels.

⚠ WARNING

- ◆ Fill water tank before turning - on - thermostat or connecting appliance to power source.
- ◆ Use only on a properly protected circuit capable of the rated load.
- ◆ Electrically ground the chassis.
- ◆ Follow national/local electrical codes.
- ◆ Do not use near combustibles.

FAILURE TO COMPLY RISKS EQUIPMENT DAMAGE, FIRE, OR SHOCK HAZARD

READ THE ENTIRE OPERATING MANUAL BEFORE BUYING OR USING THIS PRODUCT

THIS APPLIANCE IS HEATED WHENEVER CONNECTED TO A POWER SOURCE

00831.0000F 3/98 ©1998 BUNN-O-MATIC CORPORATION

00831.0000

As directed in the International Plumbing Code of the International Code Council and the Food Code Manual of the Food and Drug Administration (FDA), this equipment must be installed with adequate backflow prevention to comply with federal, state and local codes. For models installed outside the U.S.A., you must comply with the applicable Plumbing /Sanitation Code for your area.

00656.0001



00824.0002

CONTROL THERMOSTAT ADJUSTMENT

200 F 190 F 180 F

APPROXIMATE THERMOSTAT TEMPERATURE SETTINGS

28368.0004A 08/08 © 2008 BUNN-O-MATIC CORPORATION

28368.0004

⚠ WARNING

To reduce the risk of electric shock, do not remove or open cover. No user-serviceable parts inside. Authorized service personnel only. Disconnect power before servicing.

37881.0000

RINSE RINSE

PUSH and HOLD BUTTON UNTIL CUP IS 2/3 FULL, THEN RELEASE

FMD-4 28964.0004

RINSE RINSE

PUSH and HOLD BUTTON UNTIL CUP IS 2/3 FULL, THEN RELEASE

FMD-5 28964.0003

⚠ WARNING
HOT LIQUID

RELEASE BUTTON WHEN CUP IS 2/3 FULL

PLACE CUP HERE PLACE CUP HERE PLACE CUP HERE PLACE CUP HERE

FMD-4 28328.0008

⚠ WARNING
HOT LIQUID

RELEASE BUTTON WHEN CUP IS 2/3 FULL

PLACE CUP HERE PLACE CUP HERE PLACE CUP HERE PLACE CUP HERE PLACE CUP HERE

FMD-5 28328.0009

INITIAL SET-UP

1. Locate the drip tray assembly inside the dispenser door.
2. Remove the drip tray and the drip tray cover and set them aside.

CE REQUIREMENTS

- This appliance must be installed in locations where it can be overseen by trained personnel.
- For proper operation, this appliance must be installed where the temperature is between 5°C to 35°C.
- Appliance shall not be tilted more than 10° for safe operation.
- An electrician must provide electrical service as specified in conformance with all local and national codes.
- This appliance must not be cleaned by water jet.
- This appliance is not intended for use by persons (including children) with reduced physical, sensory or mental capabilities, or lack of experience and knowledge, unless they have been given instructions concerning use of this appliance by a person responsible for its safety.
- Children should be supervised to ensure they do not play with the appliance.
- If the power cord is ever damaged, it must be replaced by the manufacturer or authorized service personnel with a special cord available from the manufacturer or its authorized service personnel in order to avoid a hazard.
- Machine must not be immersed for cleaning.

ELECTRICAL REQUIREMENTS

CAUTION - The dispenser must be disconnected from the power source until specified in *Initial Set-Up*.

The 120 volt version of this dispenser has an attached cordset and requires 2-wire, grounded service rated 120 volts ac, 15 amp, single phase, 60 Hz. The mating connector must be a NEMA 5-15R.

The 120/208 and the 120/240 versions of this dispenser has an attached cordset. The mating connector must be a NEMA 14-20R.

The 220-240 volt version of this dispenser has an attached cordset.

Refer to the dispenser's dataplate and local/national electrical codes for exact voltage requirement.

ELECTRICAL HOOK-UP

CAUTION – Improper electrical installation will damage electronic components.

1. An electrician must provide electrical service as specified.
2. Using a voltmeter, check the voltage and color coding of each conductor at the electrical source.
3. Open the front door of the dispenser and place the heater switch in the "OFF" (upper position).
4. Connect the dispenser to the power source.
5. If plumbing is to be hooked-up later be sure the dispenser is disconnected from the power source. If plumbing has been hooked-up, the dispenser is ready for *Initial Fill & Heat*.

PLUMBING REQUIREMENTS

This dispenser must be connected to a cold water system with operating pressure between 20 and 90 psi (138 and 620 kPa) from a 1/2" or larger supply line. A shut-off valve should be installed in the line before the brewer. Install a regulator in the line when pressure is greater than 90 psi (620 kPa) to reduce it to 50 psi (345 kPa). The water inlet fitting is .75-11.5 NH (HOSE THREAD). For convenience an elbow adaptor is provided to convert to a 1/4" flare fitting. Bunn-O-Matic does not recommend the use of a reverse-osmosis or deionized water supply to this equipment. **REQUIRED: 1.0 gpm (3.78 lpm) flow rate from water supply line.**

NOTE - At least 18 inches of an FDA approved flexible beverage tubing, such as reinforced braided polyethylene or silicone, before the dispenser will facilitate movement to clean the countertop. Bunn-O-Matic does not recommend the use of a saddle valve to install the dispenser. The size and shape of the hole made in the supply line by this type of device may restrict water flow.

As directed in the International Plumbing Code of the International Code Council and the Food Code Manual of the Food and Drug Administration (FDA), this equipment must be installed with adequate backflow prevention to comply with federal, state and local codes. For models installed outside the U.S.A., you must comply with the applicable Plumbing /Sanitation Code for your area.

PLUMBING HOOK-UP

1. Flush the water line and securely attach it to the flare fitting on the bottom of the dispenser.
2. Turn-on the water supply.

NOTE - Water pipe connections and fixtures directly connected to a potable water supply shall be sized, installed and maintained in accordance with federal, state and local codes.

INITIAL FILL & HEAT

CAUTION - The dispenser must be disconnected from the power source throughout the initial set-up, except when specified in the instructions.

1. Turn-on the water supply and connect the dispenser to the power source.
2. Water will automatically flow into the tank to the proper level and then shut-off. This will take less than five minutes.
3. When the tank is full of water, open the front door and place the heater switch in the “ON” (lower) position. A tank full of cold water will take approximately eighty minutes for the water to heat on 120 volt versions or forty minutes for 120/208 volt versions, 120/240 volt versions, and 220-240 volt versions.

During this waiting period, complete these dispenser set-up steps:

- a. Place the drip tray in front of the dispenser. Set the drip tray cover in place.
- b. Place a set of keyholes in the cup locator plate over the screws beneath the hopper access door and push down gently.
- c. Fill the hoppers with the dry product to be dispensed.

PRESET TANK TEMPERATURE

Tank temperatures have been preset at the factory to 180°F (82°C). Bunn recommends that to provide the best quality beverage, the installer adjust the tank temperature to the powder product manufacturer’s recommended temperature for the hot powder product being used.

LIQUID LEVEL CONTROL

The system automatically maintains the hot water tank’s level by energizing the refill solenoid when the water level drops below the liquid level probe. If the system has not successfully refilled in 15 minutes, a refill error occurs. When a refill error occurs, the refill solenoid is de-energized and the left rinse L.E.D. will flash about once every 5 seconds. Once the cause of the refill error has been investigated (see the troubleshooting guide in the Operating and Service Manual) and cured, the system can be reset by placing the Rinse/Run switch in the programming (center) position, momentarily.

RINSE TIMERS

The dispenser is shipped from the factory with the rinse timers disabled. To enable the rinse timers, remove power from the dispenser, remove the lower access panel, and remove the jumper from J1 of the control boards. Replace the lower access panel, and return power to the dispenser. When enabled, the rinse timers automatically keep track of the time since the dispenser was last run through a rinse sequence. If the dispenser detects that a rinse sequence has not been run for 8 hours, the appropriate rinse L.E.D. will flash continually. If, after an additional 4 hours (12 hours total), a rinse sequence has still not been run, the appropriate rinse L.E.D. will light continuously, and the appropriate hopper drives will be disabled until a rinse sequence has been run.

RUNNING A RINSE SEQUENCE

1. Place the rinse/run switch in the rinse position.
2. Sequentially, or simultaneously, at each of the positions dispense for at least 10 seconds.
3. After the rinse L.E.D. has extinguished, the rinse timer is reset.
4. Return the rinse/run switch to the run position.

DISPENSER USE

1. Simply place a cup on the drip tray beneath the dispensing tip.
2. Press the button and dispense the beverage.
3. Release the button when the cup is approximately $\frac{2}{3}$ full and allow the whipper chamber to drain.

NOTE - The whipper chamber must drain at the end of each dispense.

COLD BEVERAGE SET-UP (OPTIONAL)

Cold beverages may be dispensed from the left dispense position. Simply place the HOT/COLD switch near the left whipper chamber in the “COLD” (upper) position.

ADJUSTMENTS

The beverage solenoid is preset to dispense approximately 9/10 ounce per second. This amount can be adjusted:

1. Disconnect the dispenser from the power source.
2. Remove the small left side access panel to adjust dispense valves 1, 2 & 3, and remove the small right side access panel to adjust dispense valves 4 & 5.
3. Rotate the control at the base of the solenoid clockwise to decrease or counterclockwise to increase the amount of water.
4. Replace appropriate access panels when finished.

HOPPER MOTOR SPEED PROGRAMING

The hopper dispense rate is preset at the factory. With 22 tooth gear and auger wire the preset dispense rate is approximately 3 to 5 grams per second. With 30 tooth gear and auger wire the preset dispense rate is approximately 5 to 7 grams per second. The hopper dispense rate can be adjusted to a range of dispense rates from approximately 1.5 to 12 grams per second, as follows:

1. Place the rinse/run switch in the center (program) position.
2. Place the increase/decrease switch in the desired (increase or decrease) position.
3. Press and release the dispense switch for the chamber you wish to adjust. Each time the dispense switch is pressed, the rinse L.E.D. will flash, and the motor speed for that hopper will be increased/decreased by approximately 2-1/2%.
4. Return the rinse/run switch to the run position after hopper motor speed adjustments are complete.

DRAINING THE HOT WATER TANK

CAUTION - The dispenser must be disconnected from the power source throughout these steps.

1. Disconnect the dispenser from the power source.
2. Place the tank heater switch in the "OFF" position.
3. Shut-off and disconnect the incoming water supply.
4. Remove the front, lower access panel.
5. Pull out drain tube to empty into a sink or a container with a minimum of 6-1/2 gallon capacity.
6. Make sure drain clamp is closed. Then, remove drain plug.
7. Direct tube into sink or container and open drain clamp. Continue draining tank until ALL of the water is out.

WARNING: Be very careful with the draining water because it can be very hot.

8. Close drain clamp, insert drain plug, place drain tube back into machine, and replace lower access panel.

NOTE - The dispenser must be refilled using the *INITIAL FILL & HEAT* steps before reconnecting to the power source.

PREVENTIVE MAINTENANCE

Bunn-O-Matic® Corporation recommends that preventive maintenance be performed at regular intervals. Maintenance should be performed by a qualified service technician. For Technical Service, contact Bunn-O-Matic® Corporation at 1-800-286-6070.

NOTE: Replacement parts or service caused by failure to perform required maintenance is not covered by warranty.

Cycle (months)	Item	Part Number
6	Mixing Chamber Kit	32906.0000
6	Whipper Motor Seal Kit	29128.0000
3 or as needed	Whipper Shaft Seal Kit	26356.1000

CLEANING

The use of a damp cloth rinsed in any mild, non-abrasive, liquid detergent is recommended for cleaning all surfaces on Bunn-O-Matic equipment. Do **NOT** clean this equipment with a water jet device.



1 x 24h

BUNN®

1. Rinse out Whipper Chambers by placing RINSE/RUN switch in the "RINSE" position and activating DISPENSE switches.
2. Turn elbow up, remove Hoppers, refill with product and replace hoppers into dispenser.
3. Empty Drip Tray and wash in a solution of dish detergent.

1. Para limpiar las camaras de mezcla, coloque el interruptor en la posición ENJUAGUE/MARCHA ("RINSE/RUN") y pulse el boton para espumar y distribuir la bebida ("DISPENSE").
2. Gire el codo hacia arriba, remueva las tolvas, llene las tolvas con producto y coloque las tolvas nuevamente en la maquina.
3. Vacie la bandeja de goteo y limpiela con un detergente liquido suave no abrasivo.



1 x 7d

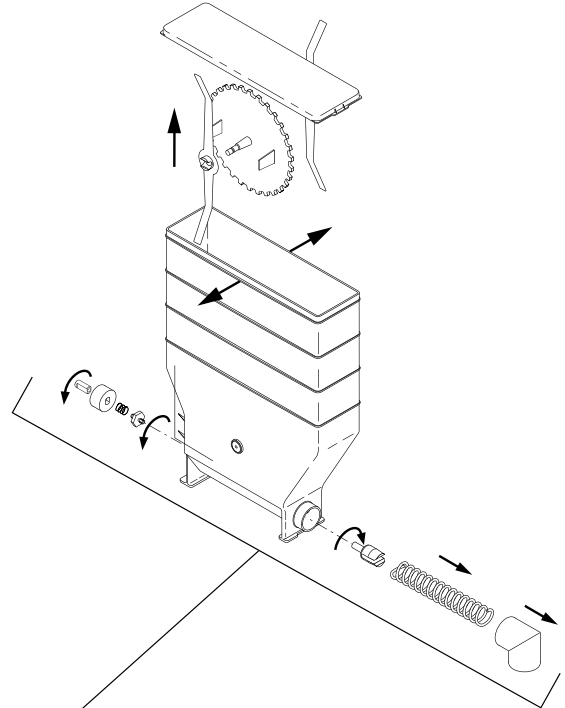
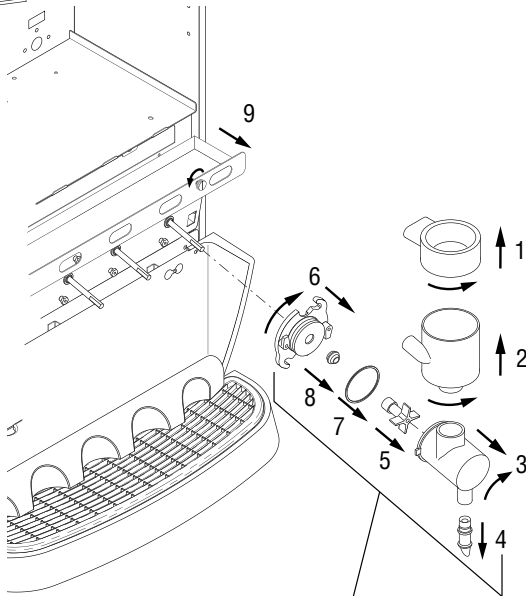

- | | |
|-------------|---------------|
| a. Wash | a. Lave |
| b. Rinse | b. Enjuague |
| c. Sanitize | c. Desinfecte |
| d. Dry | d. Seque |

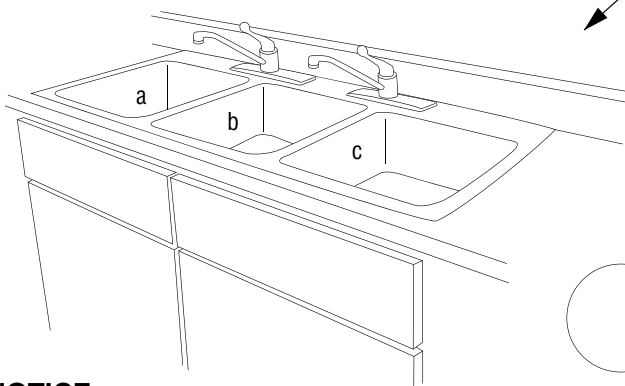

Replace Light Bulbs as required.

Cambie los bombillos quemados cuando sea necesario.

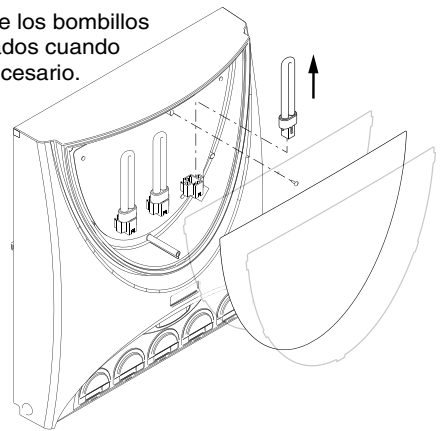

NOTICE

The cleaning instructions noted above are for non-dairy sugar based food products. When dispensing any other food product, the cleaning cycle for the whipping chamber assembly and ejector elbow must be performed daily.

NOTA:

Las instrucciones de limpieza descritas anteriormente excluyen productos lacteos azucarados. La limpieza de las camaras de mezcla y de los codos de salida de cada tolva deberá realizarse diariamente.