



INSTALLATION INSTRUCTIONS

Accessory
HEATED GRIP WITH THERMOSTAT
 P/N 08T50-MCA-102

Application
GL1800

Publications No.
 Issue Date
July 2005

Honda Dealer: Please give a copy of these instructions to your customer.

PARTS LIST

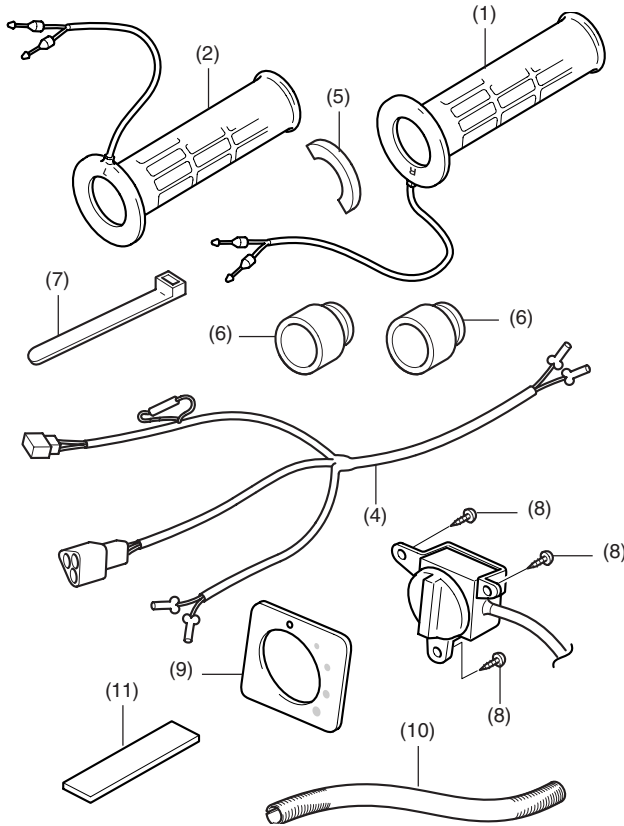

No.	Description	Qty
(1)	Right grip heater	1
(2)	Left grip heater	1
(3)	Switch	1
(4)	Heater harness	1
(5)	Clearance gauge	1
(6)	Grip spacer	2
(7)	Wire tie	12
(8)	4 mm screw	3
(9)	Switch plate	1
(10)	Corrugated tube	1
(11)	Sponge tape (used from the 03 model on)	1

TOOLS AND SUPPLIES REQUIRED

- Phillips ® screwdriver
- Electric drill motor
- Hole saw (45 mm)
- Isopropyl alcohol
- Pro Honda Handgrip Cement
- Scissors
- Scale
- Electrical Tape
- Shop towel
- Wood block
- Marker
- Torque wrench

TORQUE CHART

Tighten all screws, bolts and nuts to their specified torques. Refer to the Service Manual for the tightening torques of removed parts.

Item	N-m	kgf-m	lbf-ft
4 mm screw	1	0.1	0.7

WIRING DIAGRAM

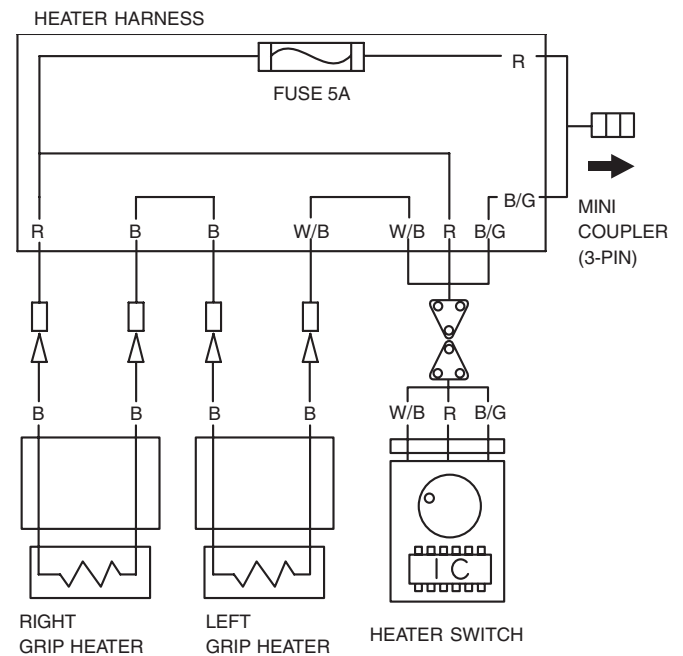

Harness Colors

B	Black
G	Green
R	Red
W	White

SPECIFICATIONS

Power source: Battery

Wattage: Approx. 35W (maximum)

Heater specifications: FPC heater
(Flexible Printed Circuit)

HEATED AREA

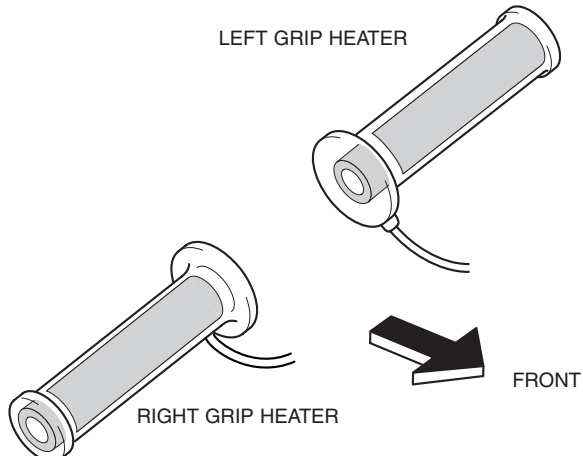

INSTALLATION

NOTE:

- Disconnect the negative cable from the battery before installing this accessory.
- The memories of the tripmeter, clock, radio and suspension system will be erased when you disconnect the battery. Reset the memories after reconnecting the battery.
- Tighten the screws, bolts and nuts securely.
- Disconnect the throttle cable from the right grip as instructed in the motorcycle's Service Manual.
- For secure adhesion of the grip heaters use the recommended adhesive agent (Honda Bond A) or equivalent.
- Reinstall the removed parts on the motorcycle and make sure that the wires and harnesses are not pinched.
- After handle grip heater installation, check the lights (e.g. right / left turn signal lights and brake lights) for proper operation.
- Be sure to open and close the throttle to check for smooth operation after installation of the right grip heater.
- Trim the excess ends off the wire ties after attaching them to the wire harnesses.

1. Remove the left grip from the handlebar pipe.

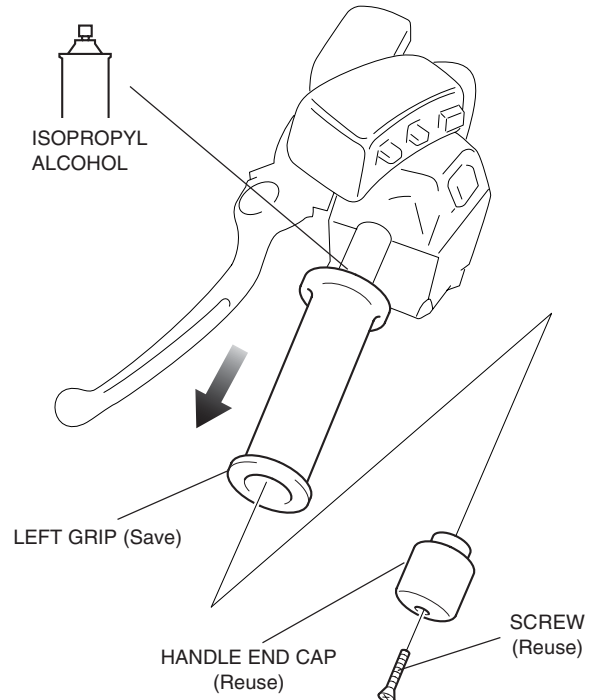

2. Using a Isopropyl alcohol, remove all traces of adhesive from the handlebar pipe.

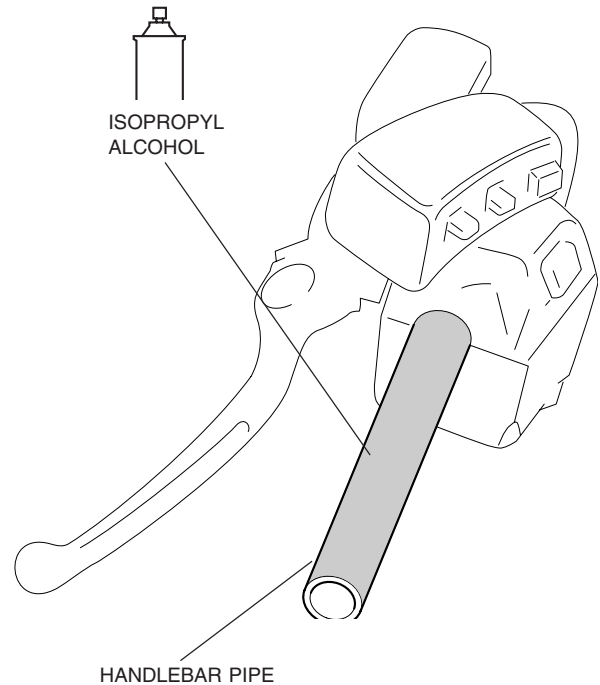

- Remove the right grip from the handlebar pipe as described in the Service Manual.

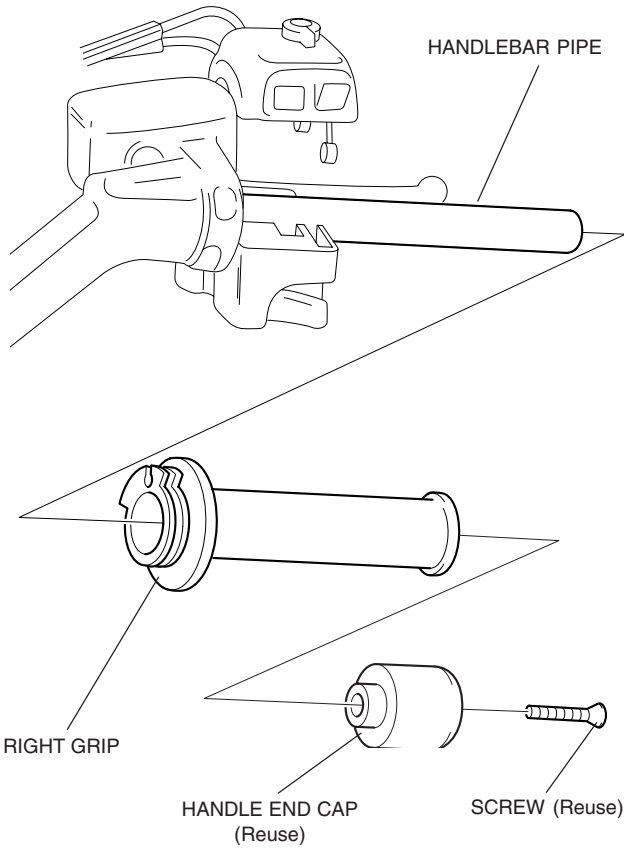

- Remove the throttle inner grip from the right grip.

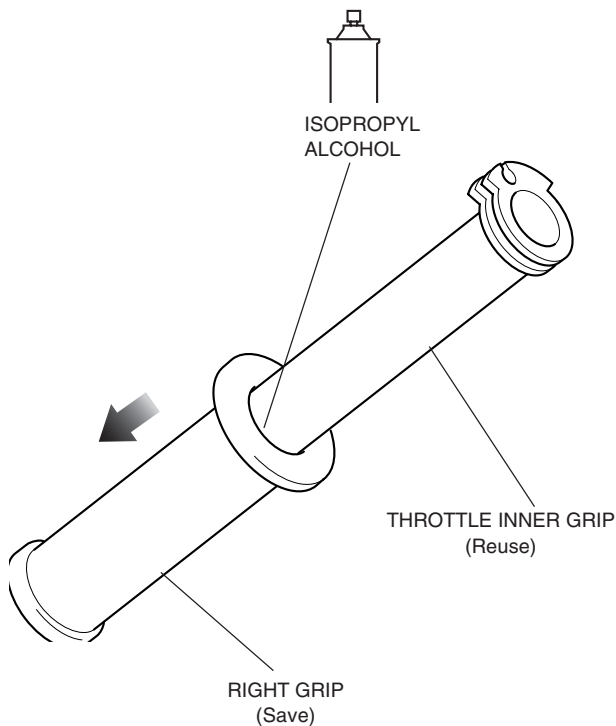

- Liberaly apply the Pro Honda Handgrip Cement to the inside of the left grip heater from the kit as shown.

NOTE

Read the Instructions of the steps 5 through 7 carefully before operation and complete the installation quickly before the adhesive agent cures. Use an assistant to steady the motorcycle while installing the grips.

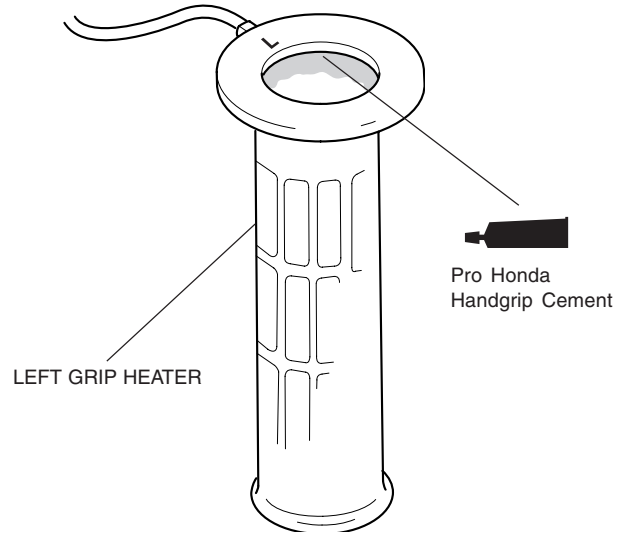

- Spray isopropyl alcohol over the inside of the grip heater and outside of the left handlebar pipe.
 - This is done to ease alignment between the heater and inner grip.**

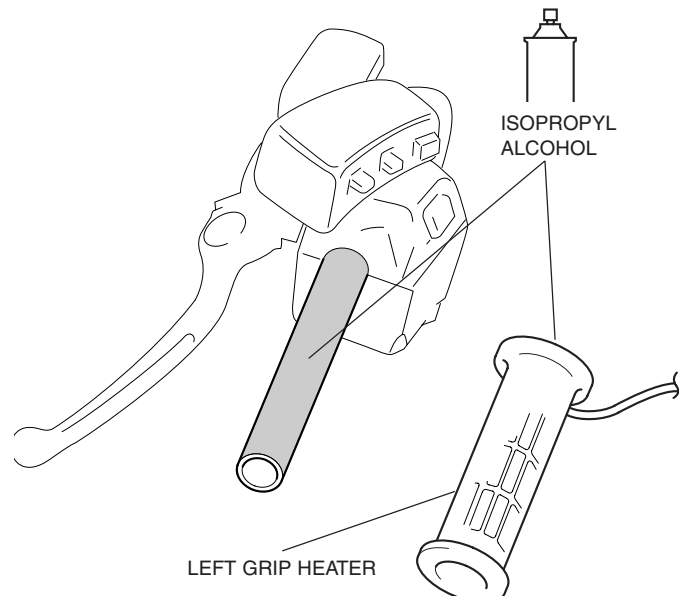

7. Slide the left grip heater onto the handlebar pipe as indicated.

- Wipe up excess adhesive at once.

NOTE

- Do not tap on the grip end with a hammer and do not twist the grip with force to insert the inner grip into the grip heater. It can cause damage to the grip heater wire.

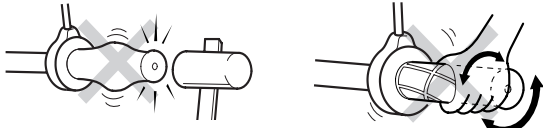

- If the grip gets stuck halfway during installation, apply isopropyl alcohol to the gap between the grip heater. Do not try to remove the heater grip using force or a screwdriver, etc. Damage to the grip heater wire can result.

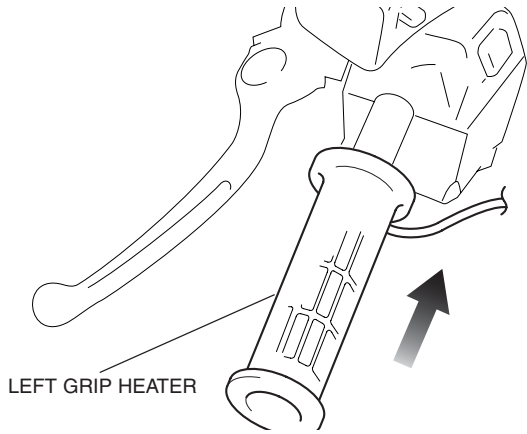

LEFT GRIP HEATER

8. Install the grip spacer as shown.

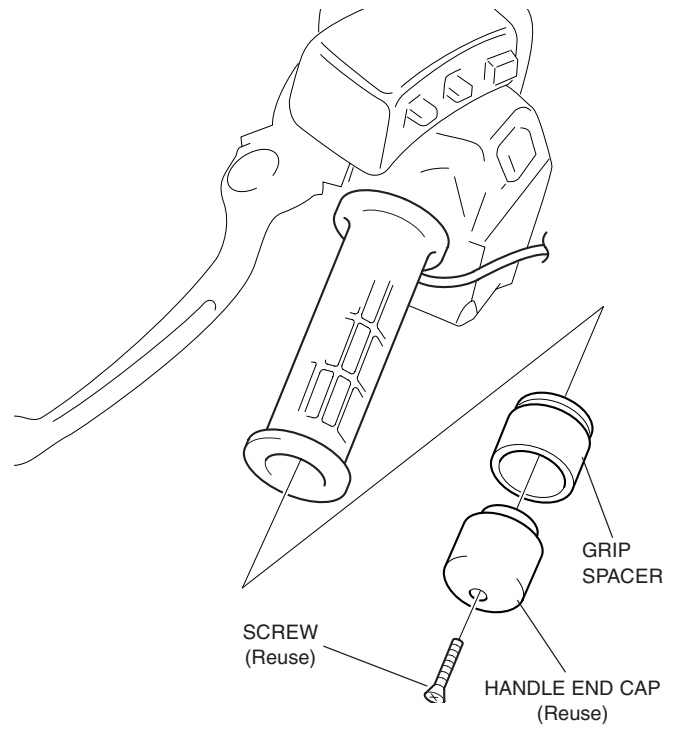

SCREW (Reuse)

GRIP SPACER

HANDLE END CAP (Reuse)

GRIP SPACER AS INSTALLED

- There should be no clearance between the handle end cap and grip spacer.

HANDLE END CAP

GRIP SPACER

RIGHT GRIP HEATER

INSTALLATION of LEFT GRIP HEATER

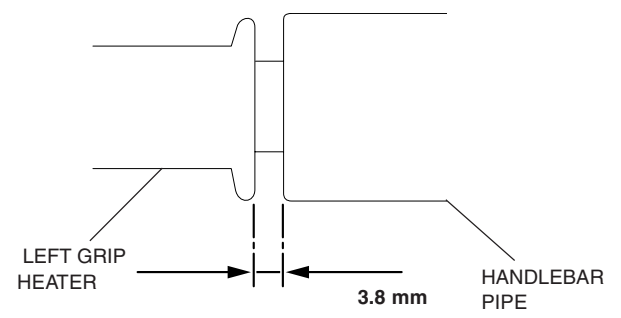

LEFT GRIP HEATER

3.8 mm

HANDLEBAR PIPE

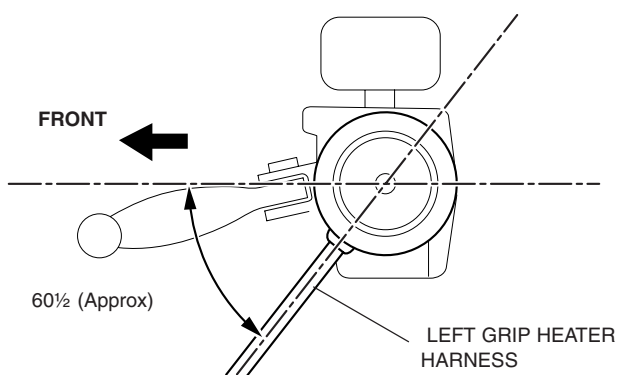

FRONT

60½ (Approx)

LEFT GRIP HEATER HARNESS

9. Using a scale and a marker, measure and mark the harnesses of the right grip heater as shown.

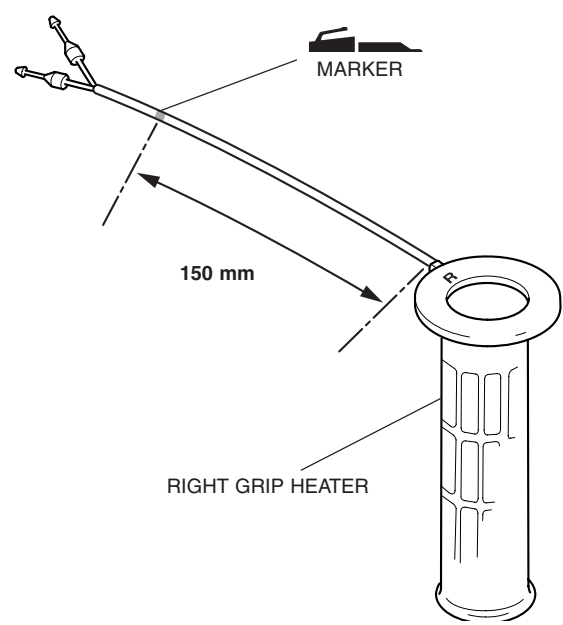

MARKER

150 mm

RIGHT GRIP HEATER

- Apply the Pro Honda Handgrip Cement to the outside of the throttle inner grip and spread it thinly all over the surface.

NOTE

Read the Instructions of the steps 10 through 12 carefully before operation and complete the installation quickly before the adhesive agent cures. Use an assistant to steady the motorcycle while installing the grips.

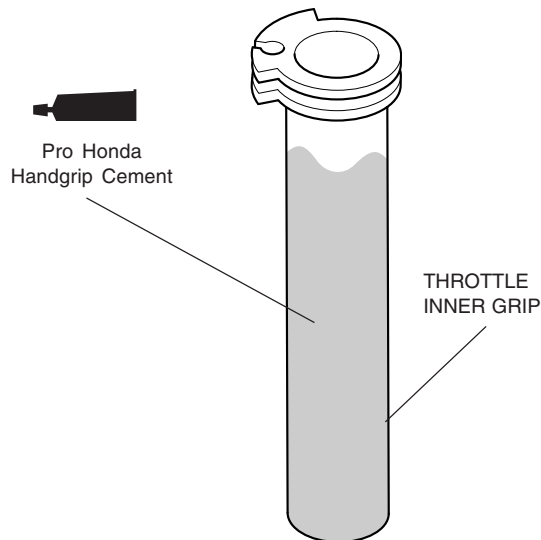

- Spray isopropyl alcohol over the inside of the right grip heater and outside of the throttle inner grip.
 - This is done to ease alignment between the grip heater and inner grip.**

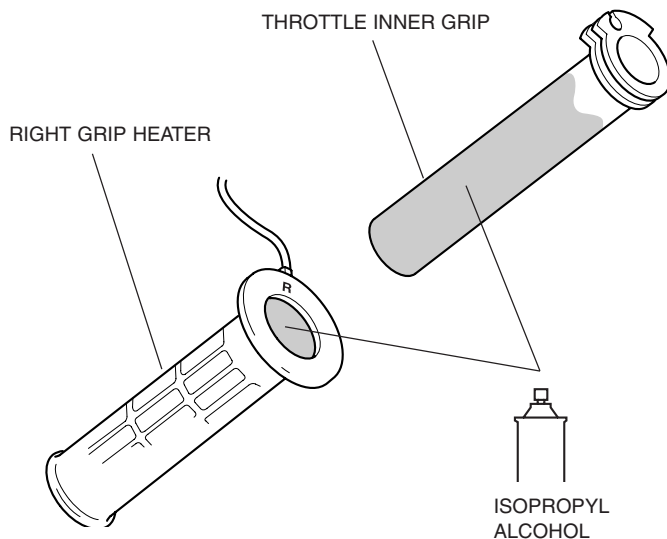

- Using the clearance gauge provided, slide the throttle inner grip into the right grip heater up to the edge of the clearance gauge. Install the right grip in the reverse order of removal.
 - Wipe up excess adhesive at once.**

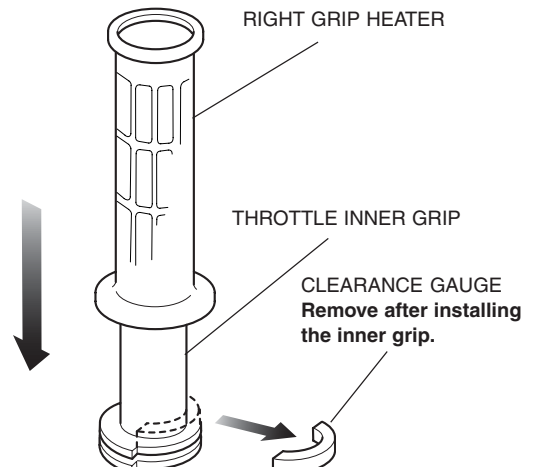

NOTE

- Do not tap on the grip end with a hammer and do not twist the grip with force to insert the inner grip into the grip heater. It can cause damage to the grip heater wire.

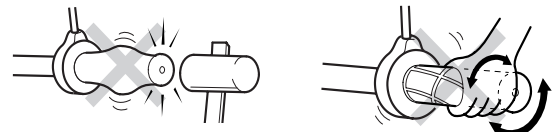

- If the grip gets stuck halfway during installation, apply isopropyl alcohol to the gap between the grip heater. Do not try to remove the heater grip using force or a screwdriver, etc. Damage to the grip heater wire can result.

- Obtain 5 mm of clearance between the right grip heater and throttle inner grip using the clearance gauge. Install the throttle inner grip so that the right grip heater harness is routed as shown when it is connected to the motorcycle.

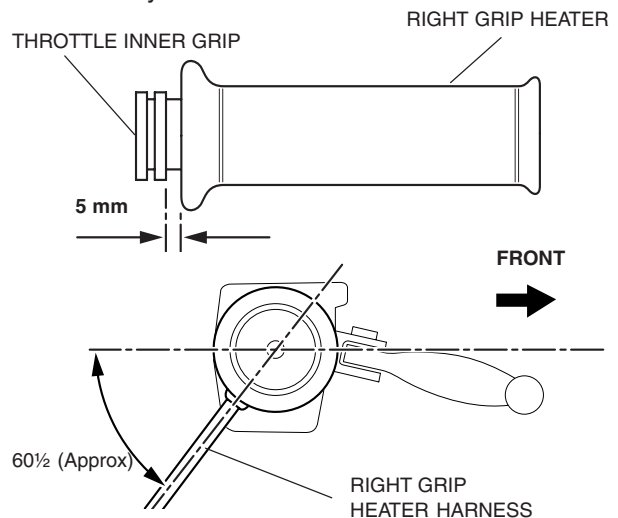

13. Install the grip spacer and handle end cap.

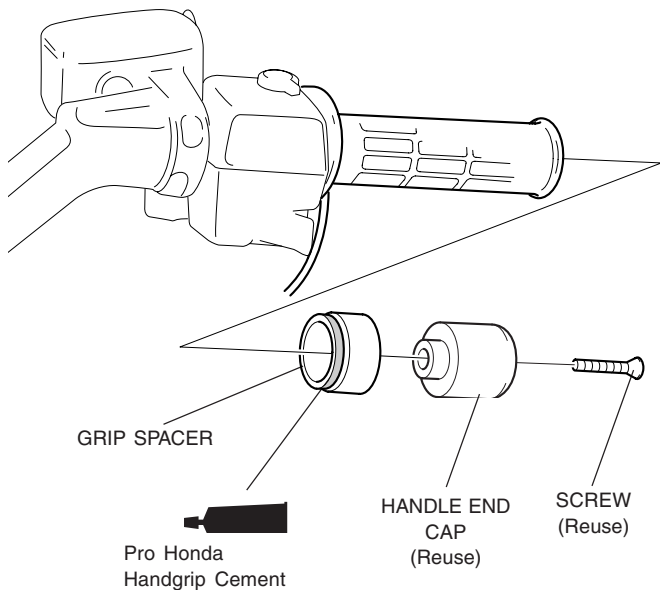

14. Open and close the throttle to check that it moves freely without binding.

15. Remove the left side cover and disconnect the negative terminal from the battery.

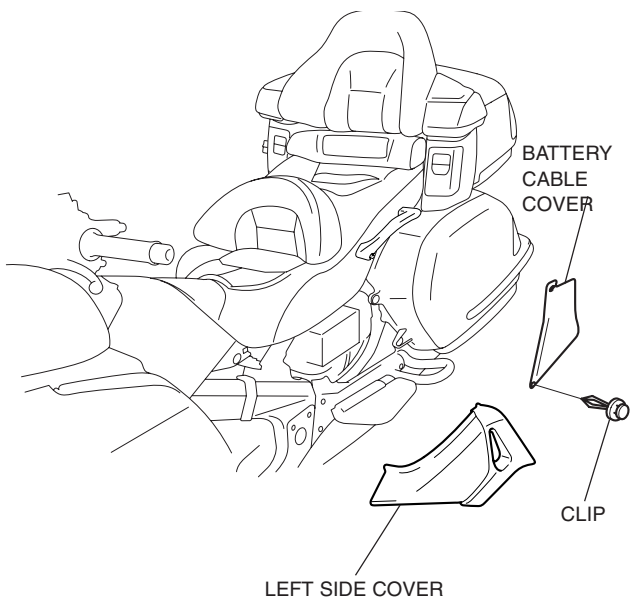

16. Remove the parts from the motorcycle as indicated in the Service Manual.

- Up to 02 year model -

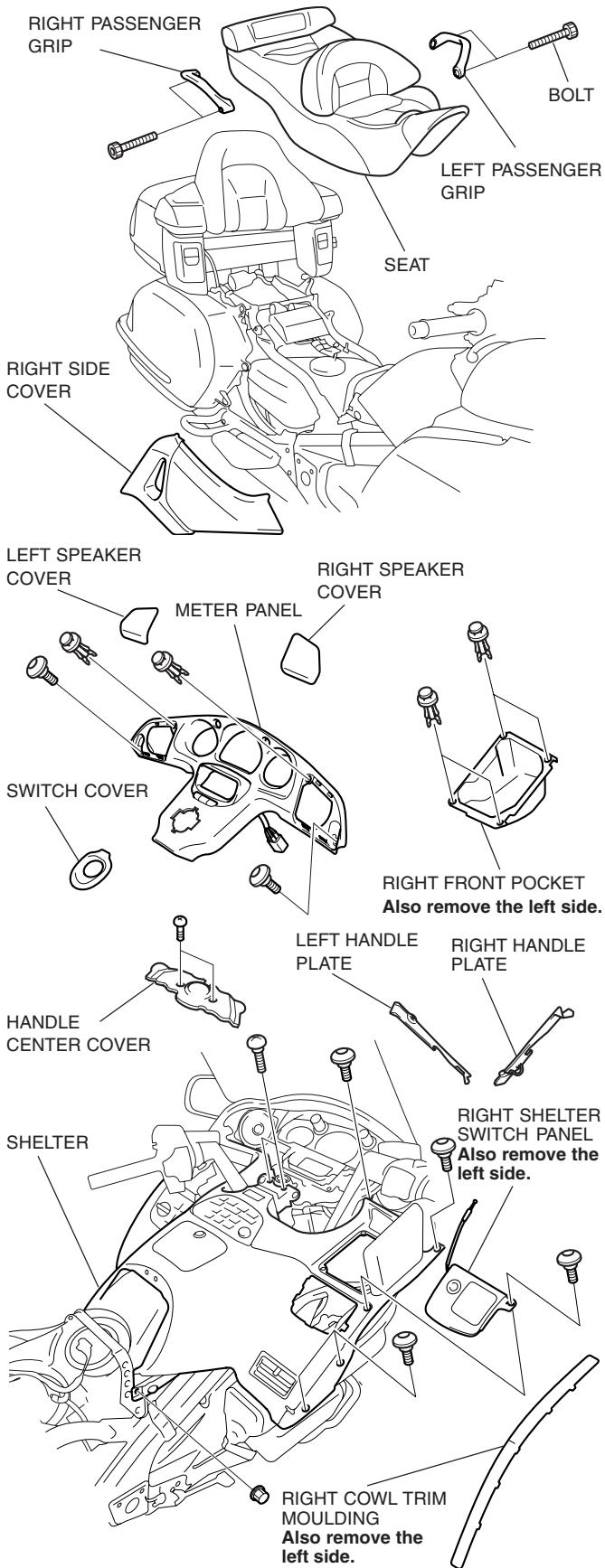

- From 03 to 05 year model -

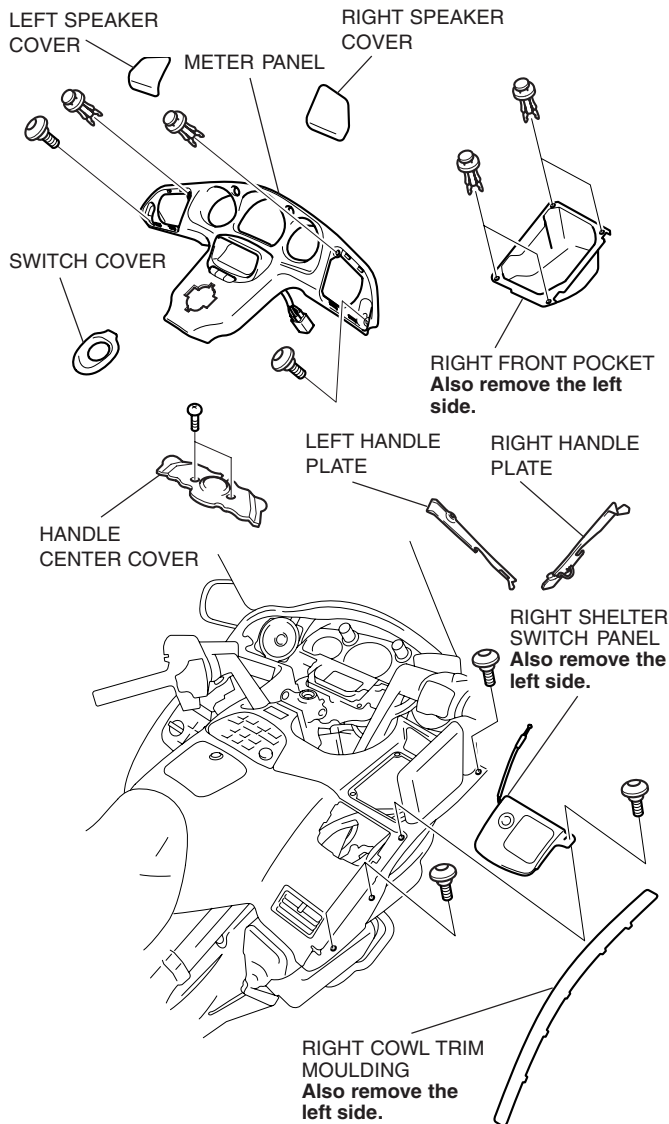

- From 06 year model -

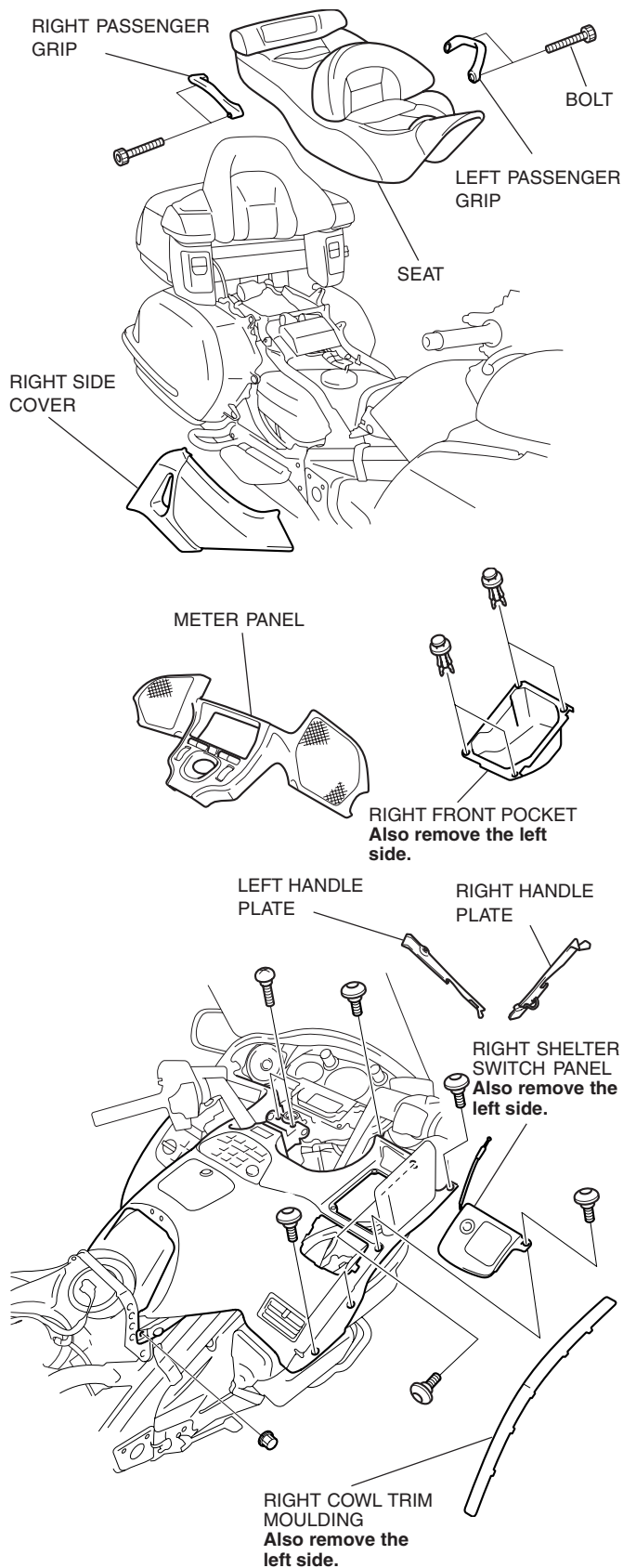

17. Locate the "x" mark on the back side of the right shelter switch panel. Drill a hole at the mark using an electric drill motor and 45 mm hole saw.
- Remove any burr after the hole has been opened.

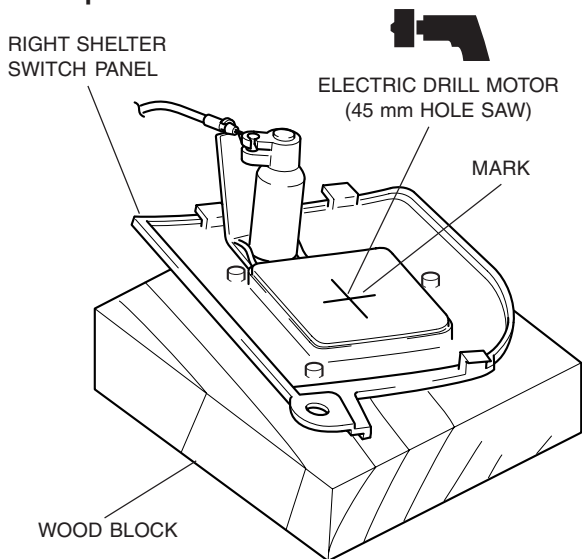

18. Remove the heater switch from the heater switch bracket.
- The procedures from the steps 18 through 27 shall be applied to vehicles up to 05 year model.

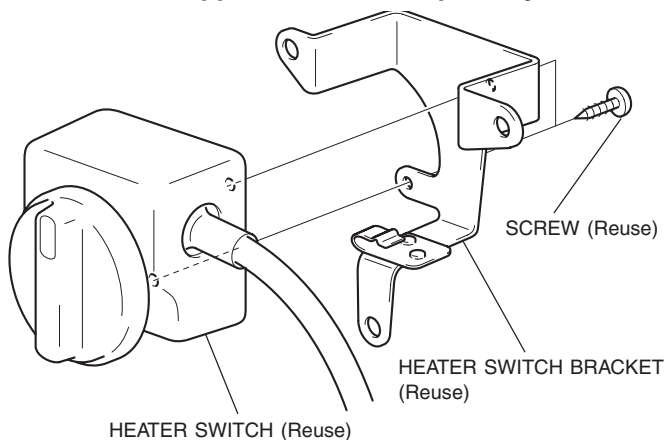

19. Install the heater switch bracket to the right shelter switch panel as shown.

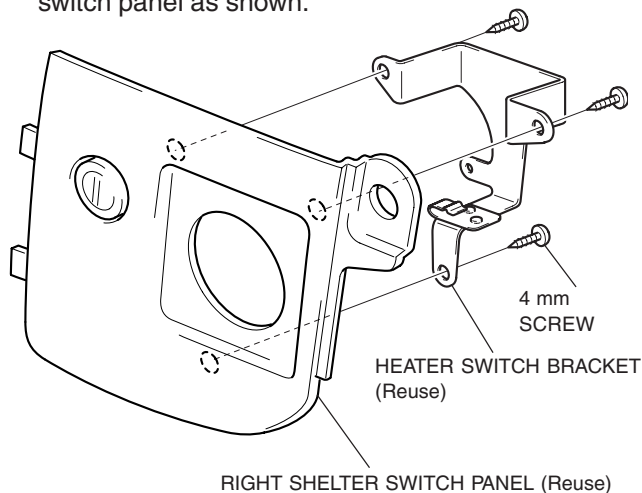

20. Disconnect the radiator breather hose as shown and cut it by the dimension shown in the figure.
- Before starting the work, cover the painted surfaces with shop towels or similar, as coolant may damage the painted surfaces if it sticks to them. If coolant should get onto any painted surfaces, wash it off immediately with water.
 - Perform the work only after the engine has cooled down sufficiently and the water temperature has dropped. After the work has been completed, tighten the hose band again.

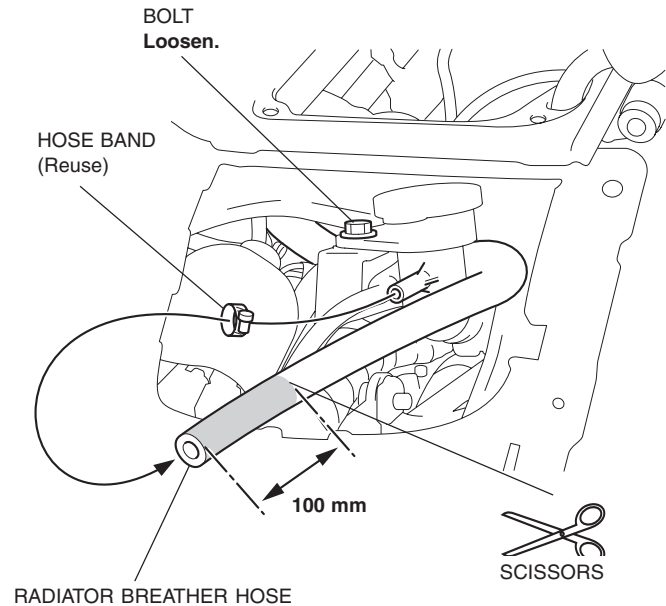

21. Mark the radiator breather hose with a felt-tip marker at the dimension shown in the figure.

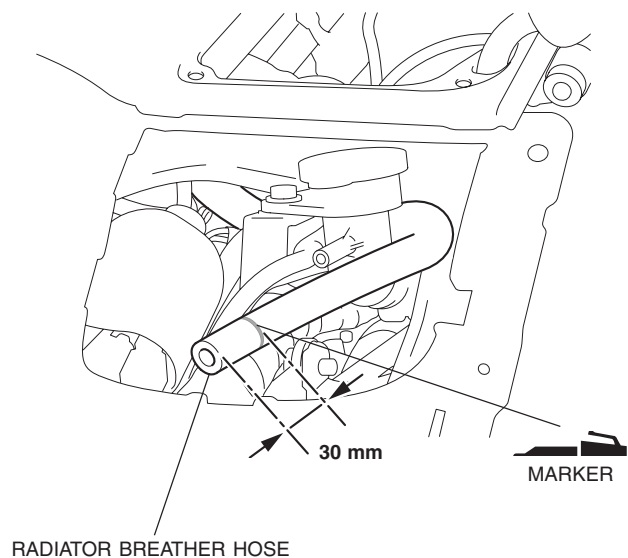

22. Route the radiator breather hose as shown.

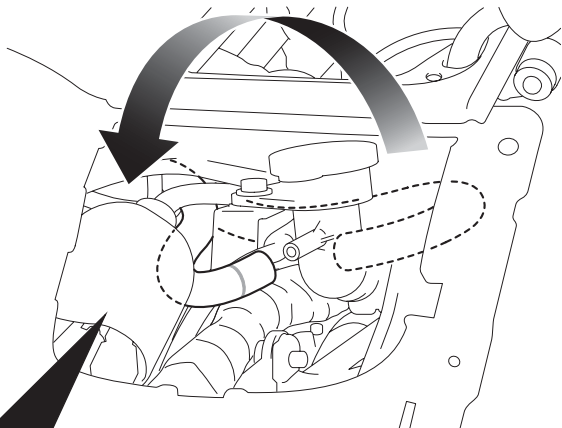

Top view

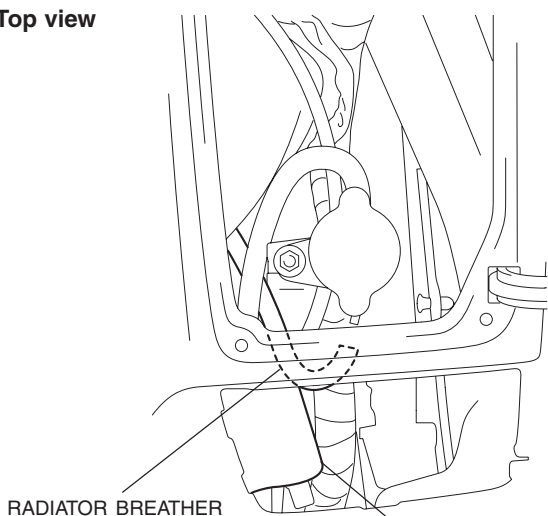

RADIATOR BREATHER HOSE
Pass underneath the harness boot.

HARNESS BOOT

23. Pass the radiator breather hose through the corrugated tube and fix the tube with tape.

RADIATOR BREATHER HOSE

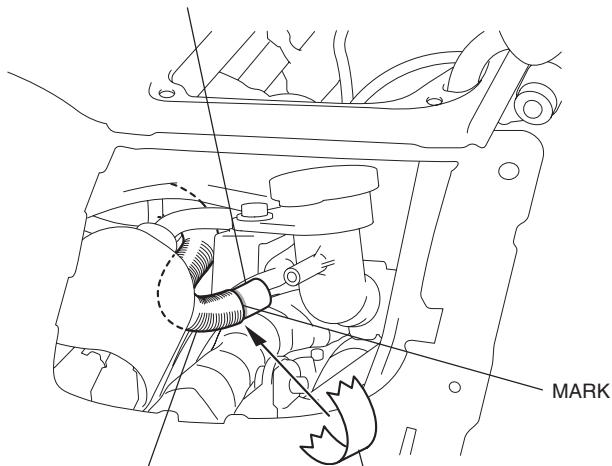

CORRUGATED TUBE
Slide onto the radiator breather hose.

MARK
TAPE
Fix the corrugated tube with tape to the radiator breather at the marked part.

24. Install the radiator breather hose in reverse order of the disconnection.

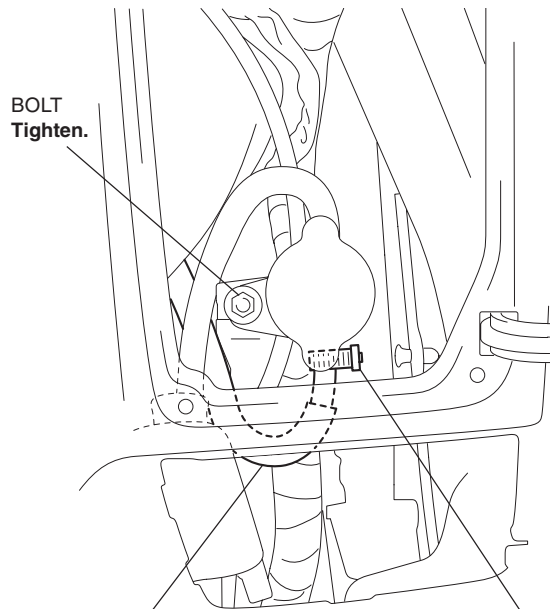

BOLT
Tighten.

RADIATOR BREATHER HOSE
passed through the CORRUGATED TUBE.

HOSE BAND (Reuse)

25. Install the right shelter switch panel provisionally and arrange so that there is no interference between the radiator breather hose and the key lock ring when the key is turned.

KEY LOCK RING PART

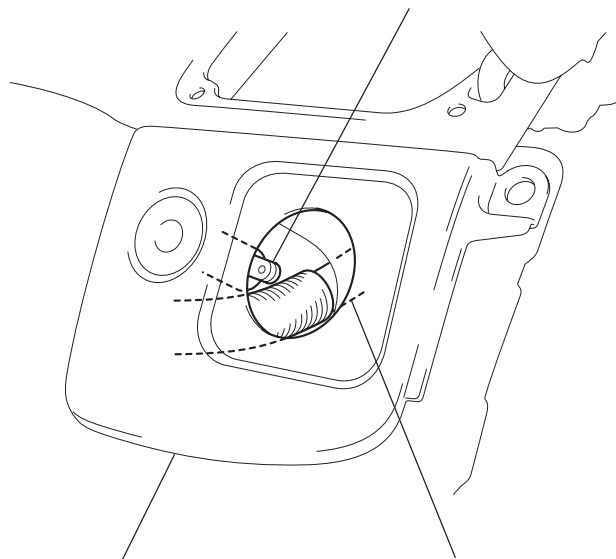

RIGHT SHELTER SWITCH PANEL

RADIATOR BREATHER HOSE
passed through the CORRUGATED TUBE.

26. Remove the right shelter switch panel and remove the heater switch bracket.

27. Install the heater switch bracket to the heater switch.

28. Install the heater switch on the right shelter switch panel using 4mm screws. Remove the paper backing from the switch plate and press it into place.

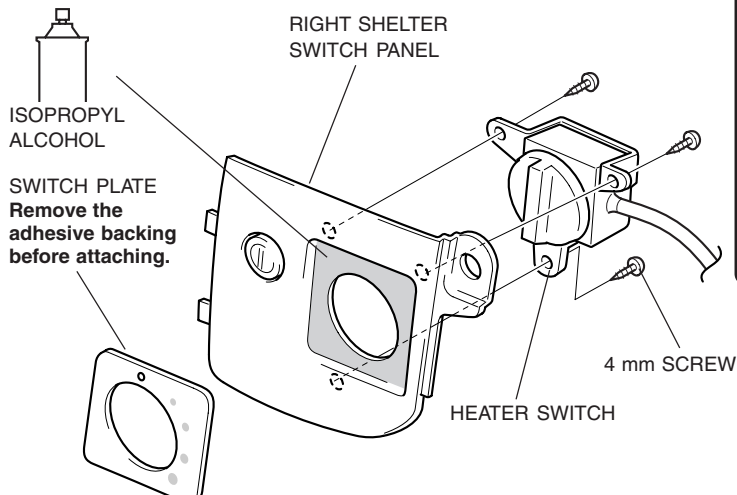

Align the end of the heater switch knob with the mark on the switch panel.

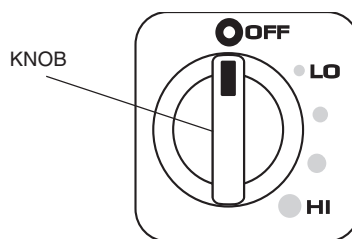

29. Route and connect the wire harnesses as shown.

- Up to 02 year model -

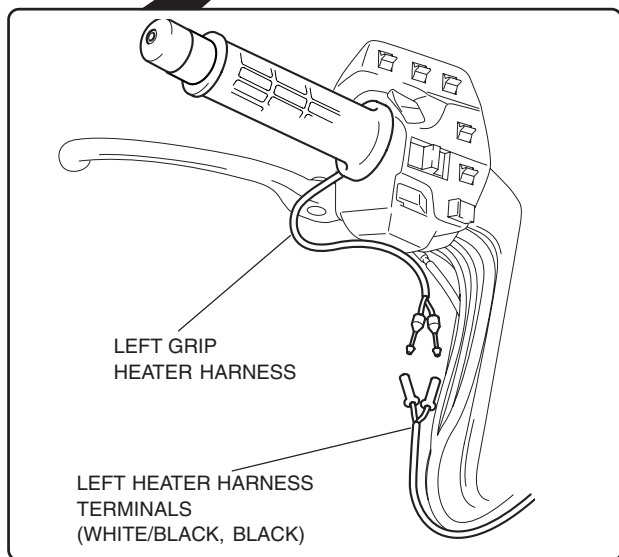
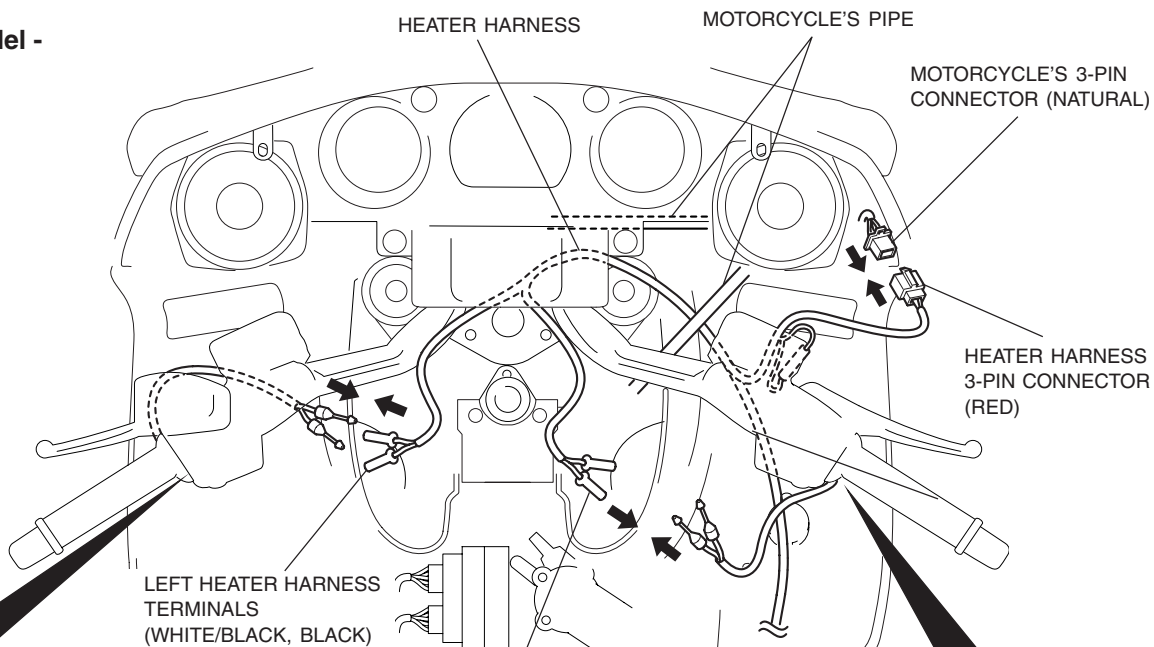

RIGHT HEATER HARNESS TERMINALS (RED, BLACK)

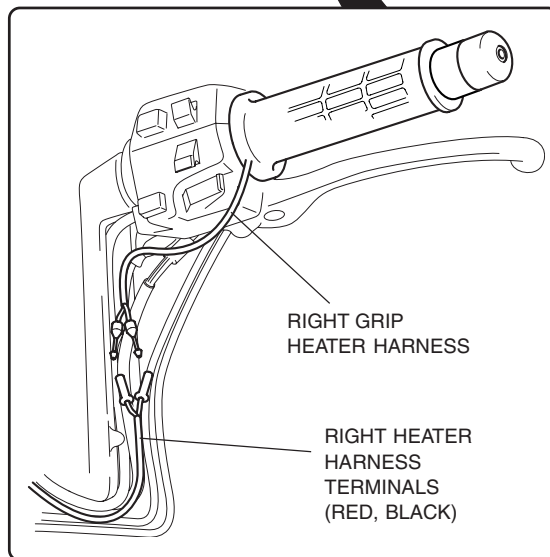

- From 03 to 05 year model -

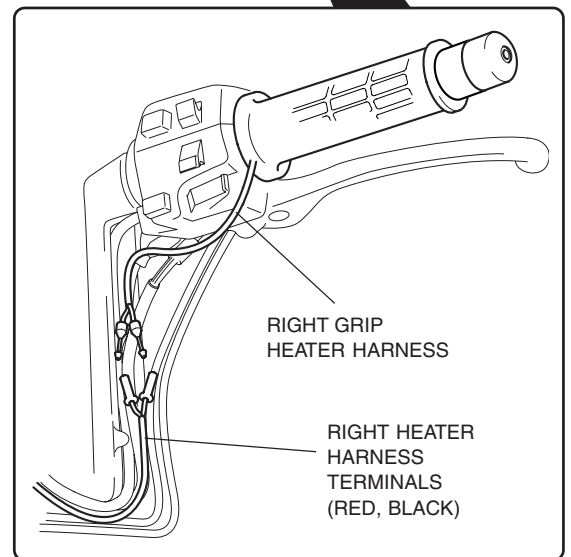
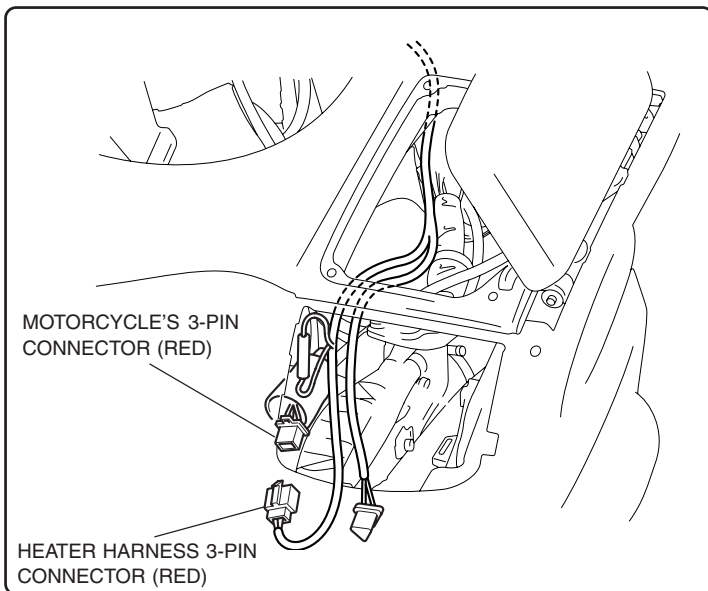
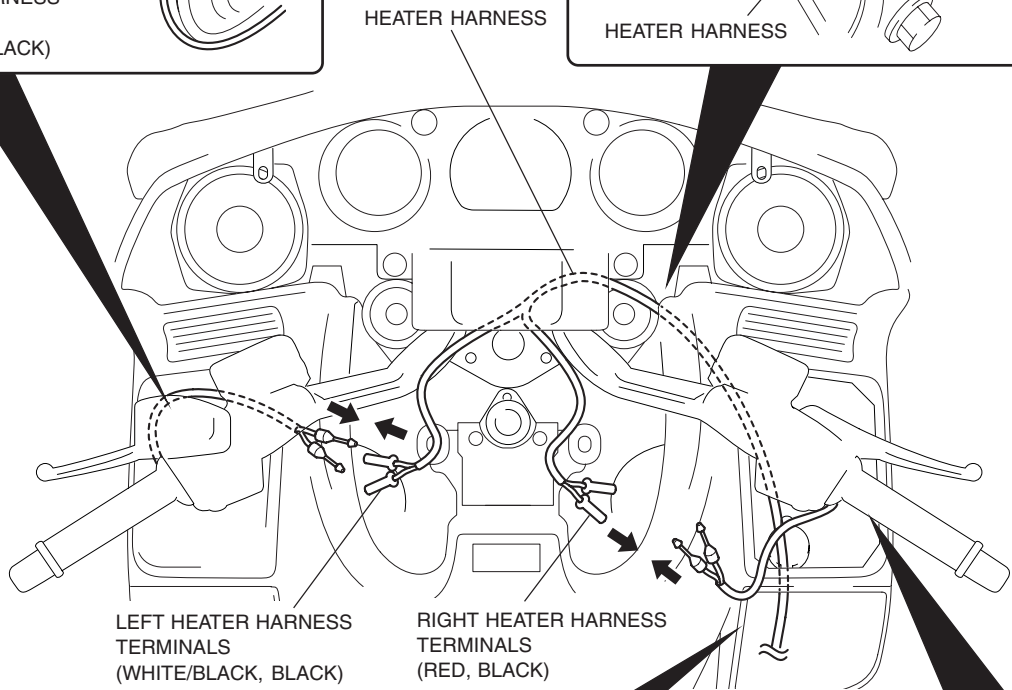
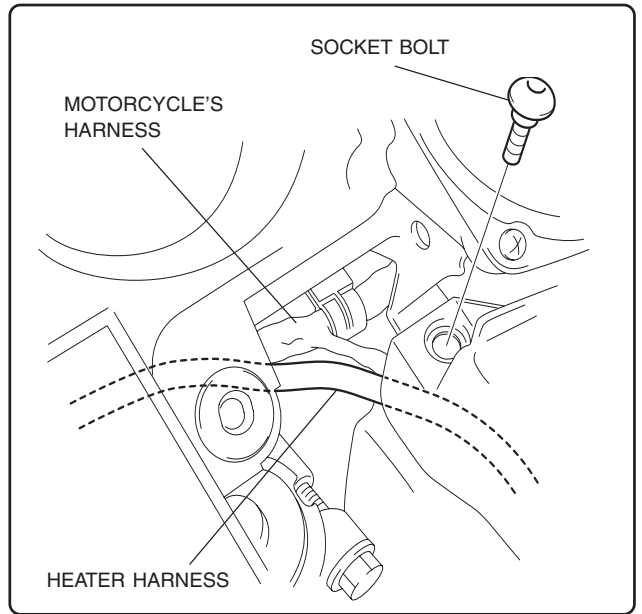
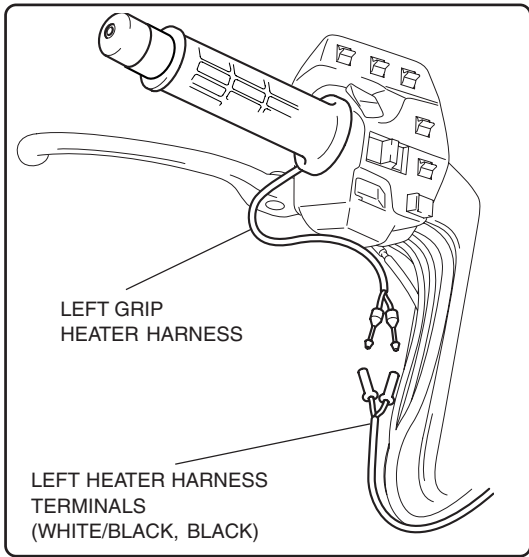

- From 06 year model -

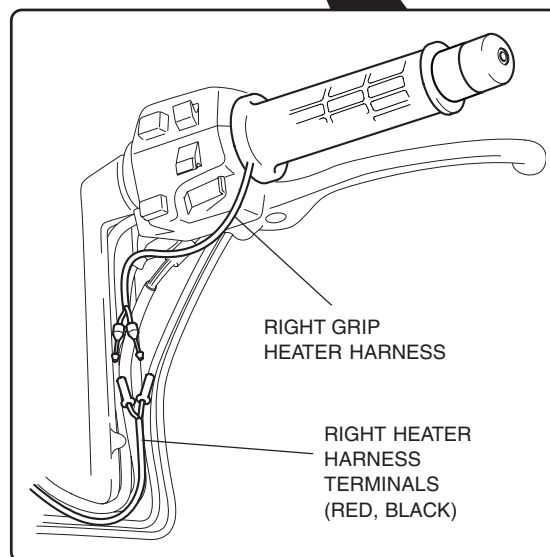
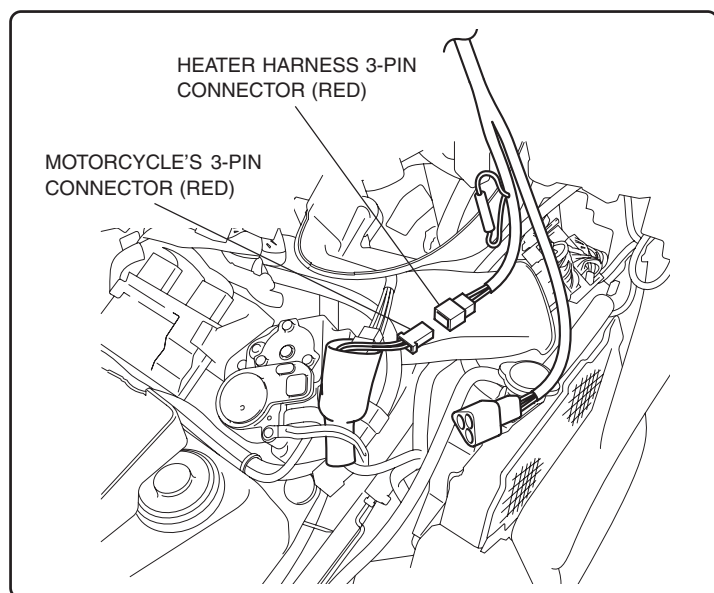
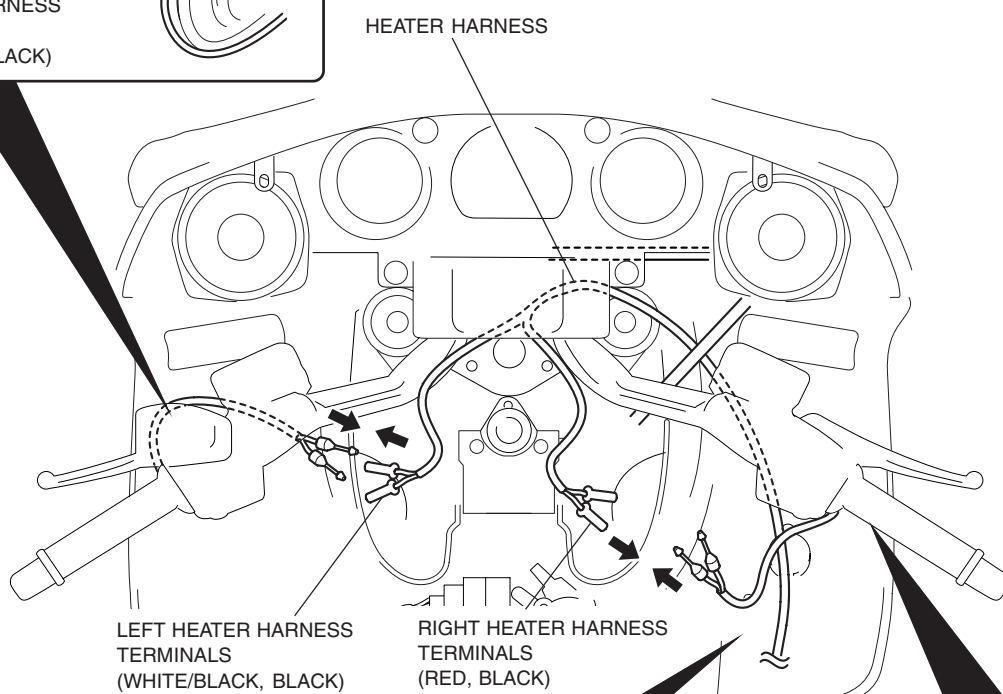
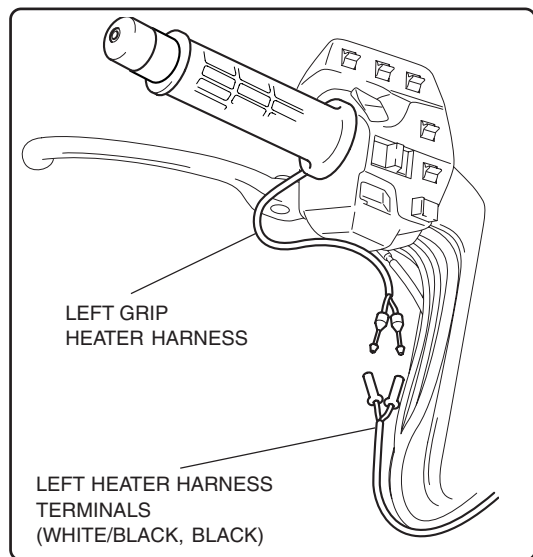

30. Secure the wire harnesses with the wire ties in the areas shown.
- Turn the handlebar to the extreme right and left to check that the wire harnesses are not pulled taut.
 - Push the grip heater harness into handle plate.

- Up to 02 year model -

After connecting, wrap an electrical tape around the terminals.

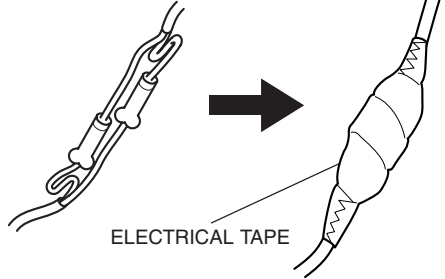

ELECTRICAL TAPE

WIRE TIES
Secure to the motorcycle's harness.

After squeezing the wire tie, check that the wire harness is not sagged or pulled taut by opening and closing the throttle several times.

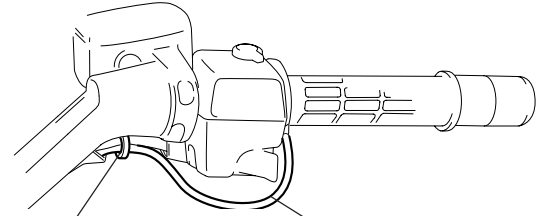

WIRE TIE
Secure to the motorcycle's harness at the marked location.

RIGHT GRIP HEATER HARNESS

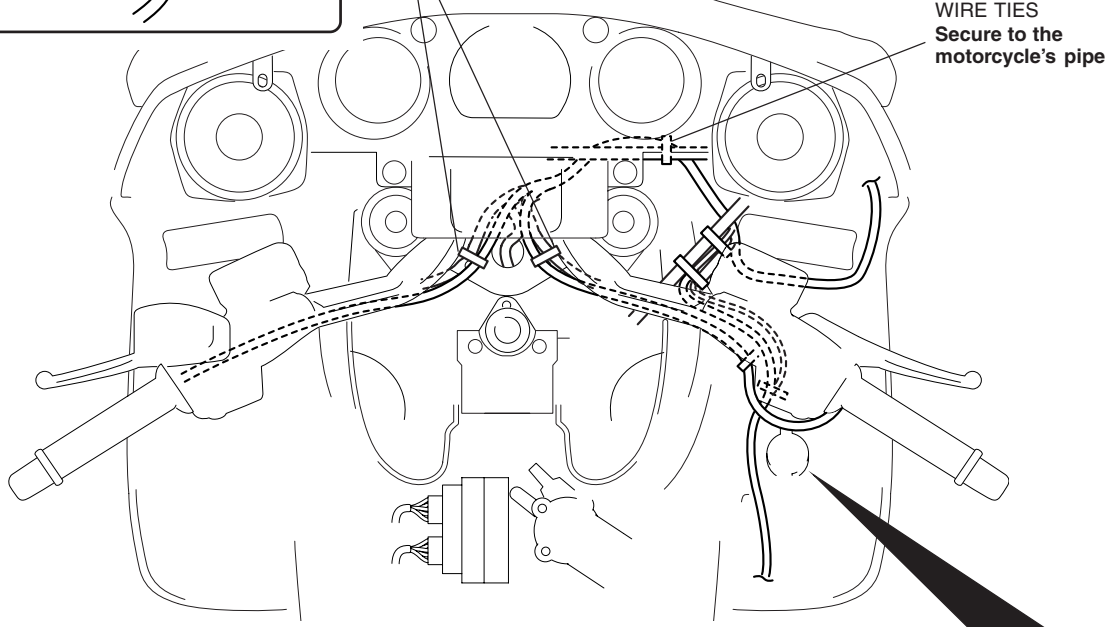

WIRE TIES
Secure to the motorcycle's pipe

Route the wire harness avoiding the radiator cap; then, secure the harness with the wire tie and install the right shelter switch panel.

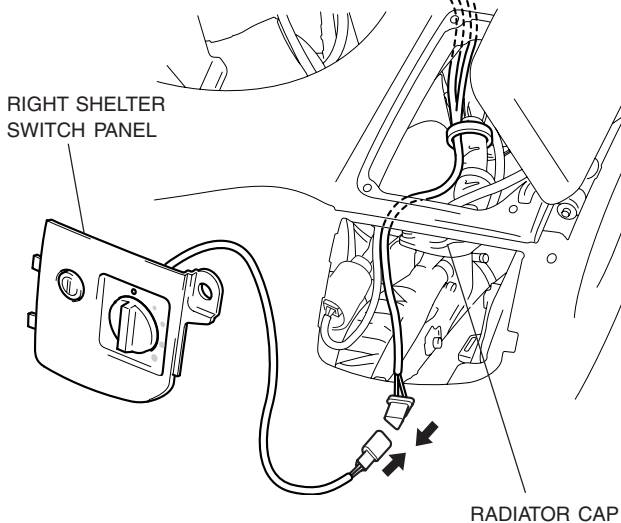

RIGHT SHELTER SWITCH PANEL

RADIATOR CAP

MOTORCYCLE'S HARNESS CLAMP
Secure to the motorcycle's pipe.

MOTORCYCLE'S PIPE

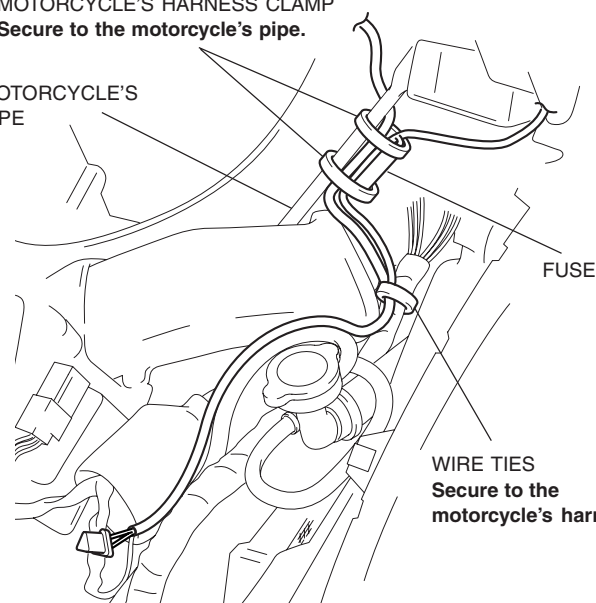

FUSE

WIRE TIES
Secure to the motorcycle's harness.

- From 03 to 05 year model -

After squeezing the wire tie, check that the wire harness is not sagged or pulled taut by opening and closing the throttle several times.

After connecting, wrap an electrical tape around the terminals.

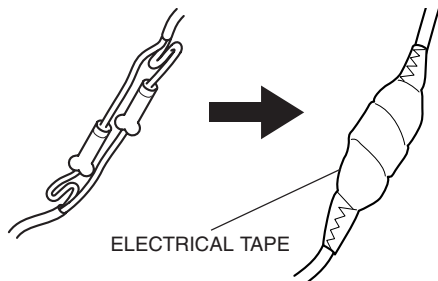

WIRE TIES
Secure to the motorcycle's harness.

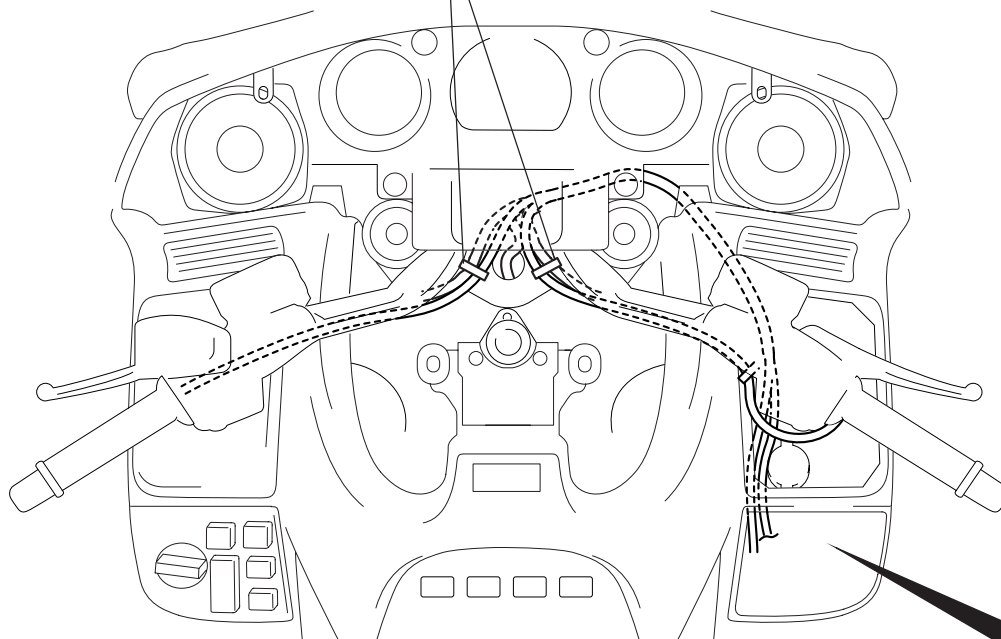
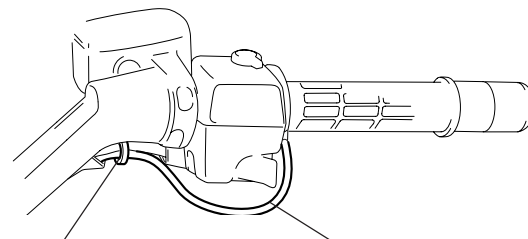

Route the wire harness avoiding the radiator cap; then, secure the harness with the wire tie and install the right shelter switch panel.

WIRE TIES
Secure to the motorcycle's harness.

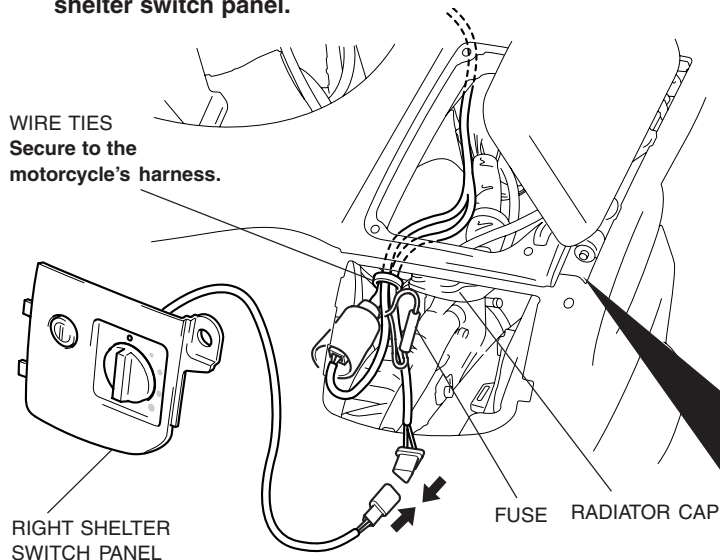

SPONGE TAPE
Fix the harness.

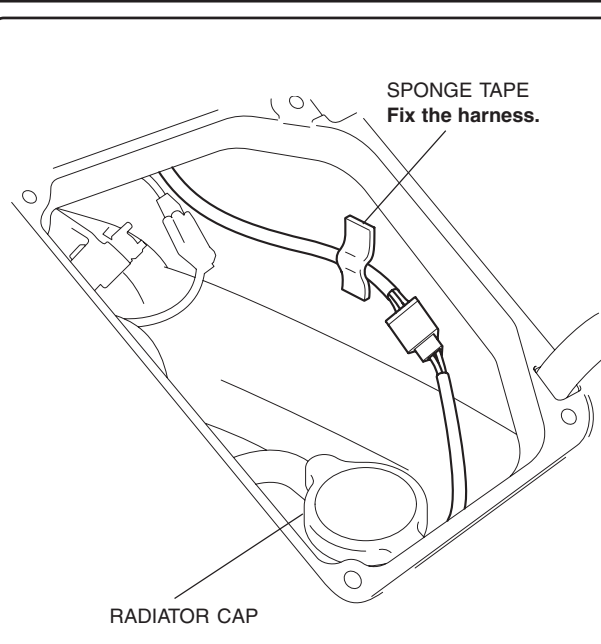

- From 06 year model -

After connecting, wrap an electrical tape around the terminals.

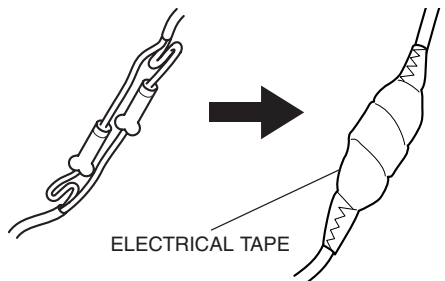

WIRE TIES
Secure to the motorcycle's harness.

After squeezing the wire tie, check that the wire harness is not sagged or pulled taut by opening and closing the throttle several times.

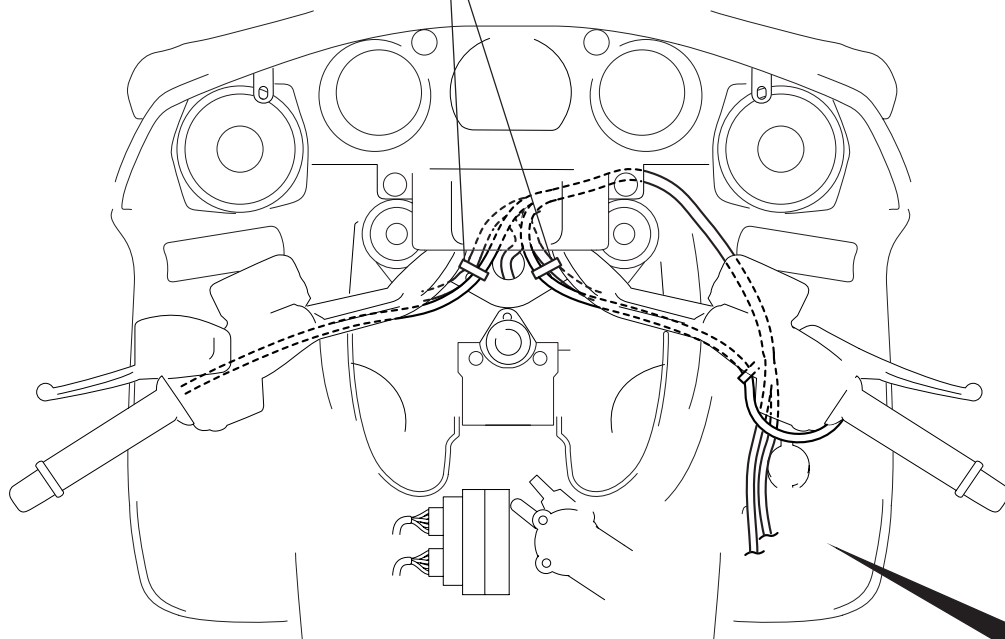
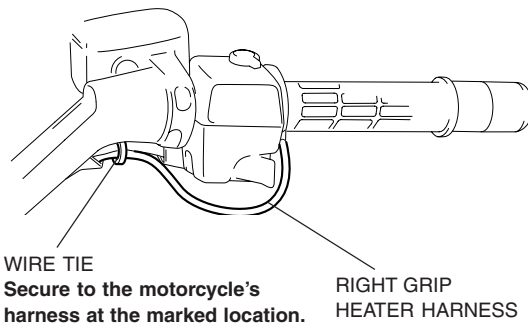

Route the wire harness avoiding the radiator cap; then, secure the harness with the wire tie and install the right shelter switch panel.

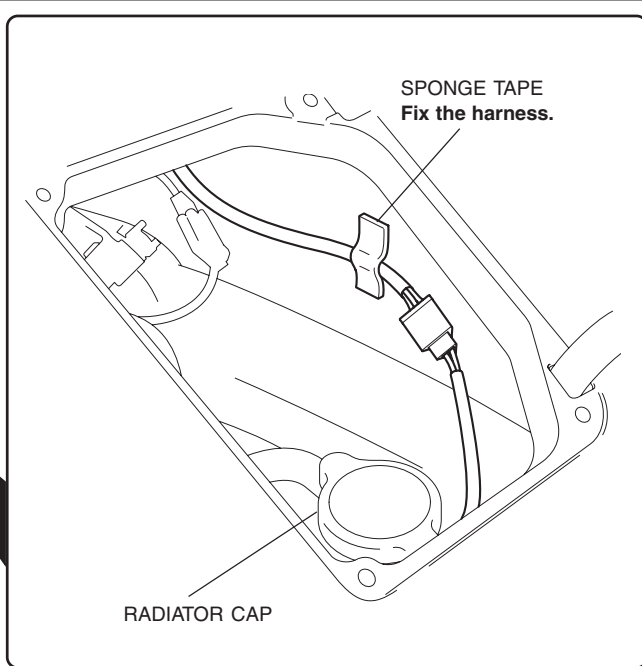
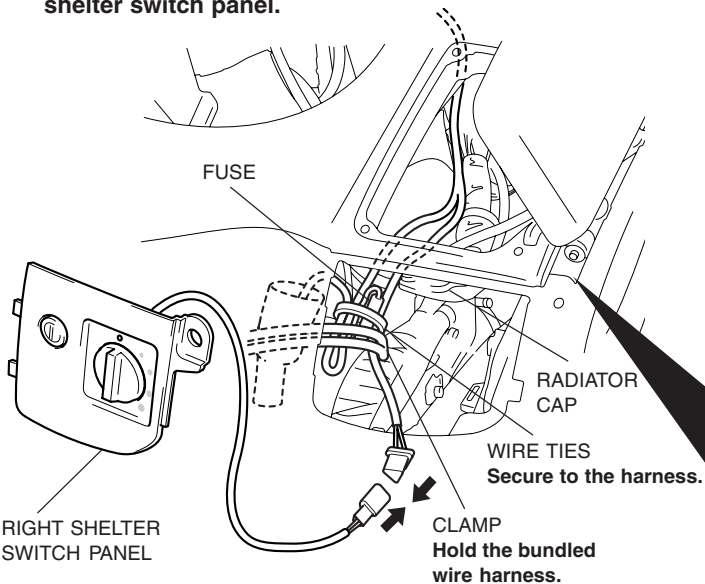

31. Reinstall all removed parts.
32. Reconnect the negative cable to the battery.
33. Check the following:
 - Operation of the grip heaters.
 - Smooth operation of the throttle without binding.
 - Operation of all lights.

OPERATION

- Do not operate the grip heater switch during driving.
- Wear gloves whenever operating the handle grip heater.
- Do not operate the handle grip heater with worn or torn surface rubber. Replace the handle grip heater with a new one.
- The grip heater is connected to the DC circuit from the battery. The grip heater is incorporated with the automatic switch that turns ON/OFF by detecting the voltage to prevent dead battery. Therefore, the switch can turn OFF automatically when the battery voltage drops, e.g. when the motorcycle comes to a halt or when running slowly. The switch turns ON automatically when the battery voltage rises and the motorcycle is running at a normal driving speed.
- Note that the heater temperature is proportional to the atmospheric temperature. Do not set the grip heater at "Hi" position when the atmospheric temperature is high (20½C or above).
- When the motorcycle is crawling along, the automatic switch may or may not turn ON according to the battery condition when the heater switch is turned ON.
- Use only the 5A fuse to replace the grip heater fuse.
- The battery is a consumable part and the grip heater does not operate when the battery runs down. Check the battery periodically and replace if necessary.

USER TROUBLESHOOTING

- Check the following if the grip heaters do not operate properly.
- If the grip heaters do not operate after following the troubleshooting procedures, contact your local Honda motorcycle dealer.

Symptom	Check
Grip heater does not operate at all or temperature cannot be adjusted properly.	<ol style="list-style-type: none"> 1. Is the engine running? 2. Is the heater switch between the Hi and Lo positions with the engine running? 3. Check by raising the engine speed.
Heater temperature is too low or too high.	<ol style="list-style-type: none"> 1. Is the heater temperature set between Hi and Lo? 2. Is the motorcycle frequently operated at idle or low speed? 3. If the temperature is too high, move the switch to the Lo position or turn the switch Off, or wear thick gloves.
Grip heater is partly warmed.	<ol style="list-style-type: none"> 1. This is not a problem. Heat is concentrated at the finger part.

DEALER TROUBLESHOOTING

- Stop the engine and turn the main switch OFF when you check the parts and circuits other than those of the grip heaters.

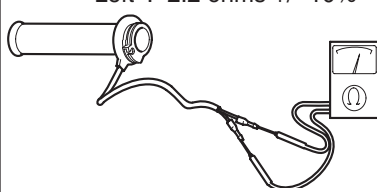
Symptom	Check
Grip heater does not operate; <ul style="list-style-type: none"> • Faulty grip heater • Faulty grip heater coil • Blown fuse • Open or short circuit in heater harness • Faulty heater switch 	<ol style="list-style-type: none"> 1. Check whether wires and cables (terminals and connectors) are connected securely. 2. Grip heater inspection Check for resistance between the terminals. ➔ Standard: Right: 2.2 ohms +/- 10% Left : 2.2 ohms +/- 10%  <ol style="list-style-type: none"> 3. Heater harness inspection: Check for continuity by referring to the wiring diagram. 4. If no abnormality is found after the above checks 1, 2, and 3, but the grip heater still does not operate properly, replace the heater switch with a new one. <ul style="list-style-type: none"> • It is hard to check the switch in ordinary inspection method (for continuity etc.) because it contains an IC circuit.