

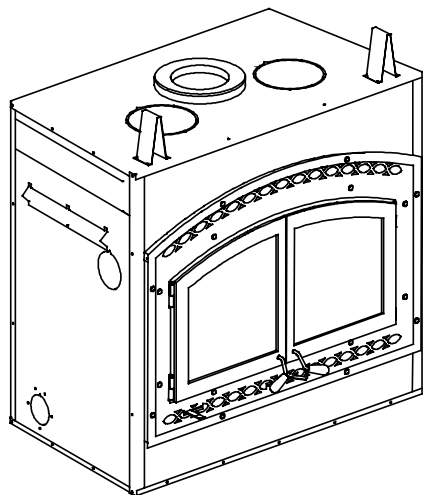

HEARTH PRODUCTS



RETAIN THESE INSTRUCTIONS FOR FUTURE REFERENCE

# INSTALLATION AND OPERATION INSTRUCTIONS

## MONTECITO ESTATE™

EPA Wood-Burning Fireplace  
P/N 850,038M REV. C 04/2007

DAVE LENNOX  
*signature*  
COLLECTION

### MODEL

### MONTEST

This installation manual will enable you to obtain a safe, efficient and dependable installation of your fireplace system. Please read and understand these instructions before beginning your installation.

Do not alter or modify the fireplace or its components under any circumstances. Any modification or alteration of the fireplace system, including but not limited to the fireplace, chimney components and accessories, may void the warranty, listings and approvals of this system and could result in an unsafe and potentially dangerous installation.

Lennox™ wood-burning fireplaces are designed for use as a supplemental heater. They are not intended for continuous use as a primary heat source.

### ⚠ WARNINGS



- Hot! Do not touch! The glass and surfaces of this appliance will be hot during operation and will retain heat for a while after shutting off the appliance. Severe burns may result.
- Carefully supervise children in the same room as appliance.

- If small children are present in the home, it is recommended that this appliance be fitted with a Firescreen kit. See *Page 20* for ordering information.

### ⚠ WARNINGS

- The fireplace cannot be operated without a door. Consult your dealer to select the correct door model.
- Important! To assure proper alignment of glass doors: Install this fireplace in a square and plumb condition, using shims as necessary at sides and/or bottom.
- Install the fireplace only as described in these instructions.



Listed to standards:  
ULC-S610 & UL-127  
Report No. 304-7213  
EPA Cert. No. 609

NATIONAL  
FIREPLACE  
INSTITUTE



www.nficertified.org

We recommend that our woodburning hearth products be installed and serviced by professionals who are certified in the U.S. by the National Fireplace Institute® (NFI) as NFI Woodburning Specialists or who are certified in Canada by Wood Energy Technical Training (WETT).



**IMPORTANT! GENERAL SAFETY PRECAUTIONS. READ AND UNDERSTAND THESE SAFETY RULES BEFORE YOUR FIRST FIRE.**

**! WARNING**

Never leave children unattended when there is a fire burning in the fireplace.

**! IMPORTANT**

When burning wood, use **SOLID NATURAL DRY WELL-SEASONED WOOD ONLY**. Hardwoods are recommended (soft woods tend to burn very quickly).

- **DO NOT** burn treated wood, charcoal, coal, trash, cardboard, driftwood, woods dipped in tar, Christmas tree greens, pitch, pine tar, creosote, chemical chimney cleaners, flame colorants, polystyrene packaging, wood products with synthetic binders (i.e. plywood). Plywood, lumber and other misc. materials can produce abnormally high temperatures, sputtering and smoking fires and may contain hazardous chemicals to treat insects and fungus.

- Burning unapproved fuels can produce excessive temperatures, beyond the design capabilities of the fireplace and may produce excess sparks or may contain hazardous chemicals. Burning unapproved fuels can result in a chimney fire, a house fire, personal injury, death or loss of property.

**! WARNING**

Never leave your fireplace unattended while it is burning.

**! WARNING**

To avoid the risk of damaging fireplace materials and increasing the risk of fire, do not use the fireplace to cook or warm food.

**! WARNING**

**NEVER** use gasoline, gasoline-type lantern fuel, kerosene, charcoal lighter fluid, naphtha, engine oil or similar liquids to start or “freshen up” a fire in this fireplace. Keep any flammable liquids a safe distance from the fireplace at all times.

**! WARNING**

The fireplace must be operated with the doors fully opened or fully closed. If the doors are left partly opened, smoke may be drawn into the room. Use optional firescreen when doors are fully opened.

**! WARNING**

Use care when selecting window treatments for windows located near the fireplace. Avoid using combustible flowing window treatments such as curtains on nearby windows that are of sufficient length to be blown in front of an open flame when the window is opened.

Keep any combustible furniture, materials or decorative pillows at least 48" (1219 mm) from the front fireplace opening.

**! WARNING**

This fireplace has **NOT** been tested with an unvented or vented gas log set. To reduce risk of fire or injury, do not install a gas log set into this fireplace.

**! WARNING**

Be careful adding wood fuel to the fire or handling fireplace tools such as shovels, tongs or pokers.

**! WARNING**

Never modify or alter your fireplace system in any way. To do so may create a potential fire hazard and void the Limited Warranty.

**! WARNING**

The bottom refractory can be cracked by excessive abuse such as tossing heavy logs onto the grate or gouging with fireplace tools. Exercise caution when adding wood to your fireplace.

**! WARNING**

Neither the manufacturer nor the seller warrants “smoke free” operation nor are we responsible for inadequate system draft caused by mechanical systems, general construction conditions, inadequate chimney heights, adverse wind conditions and/or unusual environmental factors or conditions beyond our control.

**! WARNING**

Always ensure that the air inlet to the fireplace is free from debris and any other obstructions that can block the entrance of air.

**! WARNING**

The Montecito Estate™ must be installed with an outside air kit, which is included with fireplace.

## CONGRATULATIONS!

In selecting this LENNOX wood-burning appliance you have chosen one of the finest fireplaces available. The Montecito Estate™ is a clean burning EPA certified fireplace that is designed to provide you dependable service as well as warmth and enjoyment for many years to come.

Please carefully read and follow all of the instructions found in this manual. Please pay special attention to the safety instructions provided in this manual. This information will be useful to you now and in years to come, so keep the manual handy and refer to it as needed.

### TABLE OF CONTENTS

Safety Rules.....	Page 2
Introduction.....	Page 3
Parts Required.....	Page 3
Optional Equipment.....	Page 3
Operating The Montecito Estate.....	Page 3
Fuel.....	Page 3
Combustion Control.....	Page 4
Refueling For Best Performance.....	Page 5
Smoking – Causes And Troubleshooting.....	Page 5
Important Cautions.....	Page 6
Maintaining Your Montecito Estate.....	Page 6
Creosote.....	Page 6
Chimney Maintenance.....	Page 6
Dealing With A Chimney Fire.....	Page 6
Finish Door Casing Care.....	Page 6
Refractory Replacement.....	Page 6
Door Installation.....	Page 7
Door Adjustment.....	Page 7
Glass Care - Replacement.....	Page 7
Glass Care - Cleaning.....	Page 7
Gasket Replacement.....	Page 7
Fireplace Installation.....	Page 8
Locating The Montecito Estate.....	Page 8
Hearth Extension Requirements.....	Page 8
Framing, Facing And Mantel.....	Page 8
Hot Air Ducting Installation.....	Page 10
Gravity Kit.....	Page 10
Outside Air Kit.....	Page 12
Chimney System.....	Page 13
Chimney Installation Notes.....	Page 13
Chimney Installation Instructions.....	Page 14
Offset Chimney Installation.....	Page 15
Angled Wall Radiation Shield.....	Page 18
Chimney Support Installation.....	Page 18
Chimney Chase And Multiple Terminations.....	Page 18
Masonry Application Instructions.....	Page 19
Installation Accessories.....	Page 20
Chimney Components Lists.....	Page 20
Replacement Parts.....	Page 23
Specifications.....	Page 23
Clearances.....	Page 23
Warranty.....	Page 24

### THE FIREPLACE INTRODUCTION

The Montecito Estate wood-burning fireplace is an energy efficient, heat circulating, closed combustion fireplace. You will receive a lifetime of comfort and enjoyment from your fireplace provided it is installed, maintained and operated properly.

- Please read these instructions and retain this manual for future reference.
- Before beginning the fireplace installation, consult the local authorities to obtain your building permit and check your local building codes. Install the fireplace only as described in these instructions and using only Lennox Hearth Products components.
- The Montecito Estate is not intended for use with a gas log set. Do not use a fireplace insert or any other product with this fireplace unless it is specified by Lennox for use with this appliance. Failure to follow these instructions will void the certification and the warranty of the fireplace and may result in an unsafe installation.
- These appliances are designed to provide supplemental heat to the immediate area only. Therefore, it is advisable to have an alternate heat source when installed in a dwelling.
- These appliances are not approved for Manufactured Home installations.

### PARTS REQUIRED

#### Fireplace model: MONTEST

- **7" diameter chimney** - Model Secure Temp S-2100+, Nova Temp HT6000+, Secure Temp GX (U.S. only) or ACBI manufactured by Security Chimneys International only, including:
  - Chimney lengths
  - Elbows (where necessary)
  - Associated components as per these installation instructions
- **Decorative Doors** - Required (Order Separately - See **Page 20**)
- **Front Facade kit** - Required (Order Separately - See **Page 20**)
- **UZY5 Blower** (included in the fireplace).
- **VRUW Blower Speed Control** (included)
- **Outside air kit (Included w/Fireplace)**

### OPTIONAL EQUIPMENT

- AC Chimney Adaptor (required if using AC Chimney)
- AC Chimney Outside Air Kit
- Gravity Venting System
- Rigid Firescreen

### OPTIONAL EQUIPMENT

#### Additional Equipment (optional)

- Gravity Venting System
- TUBINOX chimney (or PROJES SS), 7" diameter with adaptor for installation in a masonry chimney.

### OPERATING THE MONTECITO ESTATE

#### Fuel - USE SOLID NATURAL WOOD FUEL ONLY.

The Montecito Estate is designed to work best when fueled with dry seasoned natural wood only. Hardwoods are preferred to softwoods since the energy content of wood is relative to its density. Hardwoods will result in a longer burning fire and less frequent refueling. A moisture content of 15% to 20% (seasoned) is recommended. Wood that has been cut and split and let to dry under a cover for a period of one year will usually meet that criteria. Excessively wet wood will be difficult to burn and will result in lower efficiency, increased creosoting and deposits on the glass and in the chimney. Excessively dry wood will burn well but will also have higher emissions and shorter burning time.

Do not burn scrap or garbage, treated wood or wood such as driftwood from the ocean which has been exposed to salt or other chemicals. Salt or chemicals can corrode the firebox and chimney. Do not burn large amounts of paper, cardboard, Christmas tree branches or building construction materials. Intense firing with these materials may overheat the fireplace, causing damage to the unit, a fire or even possibly igniting a chimney fire if the chimney is creosoted.

#### First Fires

**Before using the fireplace make sure to remove the plastic wrapping and EPA label on the door. Remove any glue residue left by the label using mild soap.**

Make sure the doors are properly adjusted, thus avoiding color change to finish due to overheating.

The first five or six fires should be small fires of short duration (about 30 to 60 minutes). This will help cure the refractory bricks. The first fires may produce slight smoking and some odor due to curing of the paint and steel and the burning of any dust accumulated on the fireplace which will burn off at this time. It may set off a smoke alarm located in the same room. For this reason the room should be well ventilated for the first few fires.

### HEAT OUTPUT

The Montecito Estate is the largest member of the "Dave Lennox Signature Collection" of high efficiency fireplaces. The heat generated from its fire is more efficiently captured and distributed. In spite of the large amount of heat that the Montecito Estate can deliver, it should not replace the main source of heat in your home. This fireplace will bring extra warmth and ambiance to your home by distributing its heat as describe further in the manual.

## COMBUSTION CONTROLS

### Primary Air & Air Boost Controls

There is no flue damper in the Montecito Estate™. As is common with air tight appliance, the combustion air control sets the flow of air entering the firebox. This allows for a more precise control of the fire. The combustion air control is located below the door on the left side. The main source of air (primary air) entering the firebox can be diminished by moving the air combustion control from left to right. The primary air is fully opened when the air control is completely moved to the left. This air combustion control should be in the closed position when the fireplace is not in operation. This will minimize air leakage up the chimney.

The combustion air control should be opened before opening the doors to minimize the possibility of back draft coming into the room (**Figure 1-A**) More details are available in *Refueling For Best Performance* on **Page 5**.

### Time Delayed Air Boost System

The time delayed air-boost system register is located underneath the door handles. Placed in the fully opened position, a timer with a maximum duration of 2 hours is engaged. The register gradually reduces the amount of air injected, allowing for a better start of the fire, whatever the conditions (See sections *Building a Fire* and *Refueling For Best Performance* for proper sequence of operation). This allows you to start the fire, set the primary air control to the desired burn level and the fireplace will automatically adjust itself to that level once the fire is fully established (**Figure 1-B**).

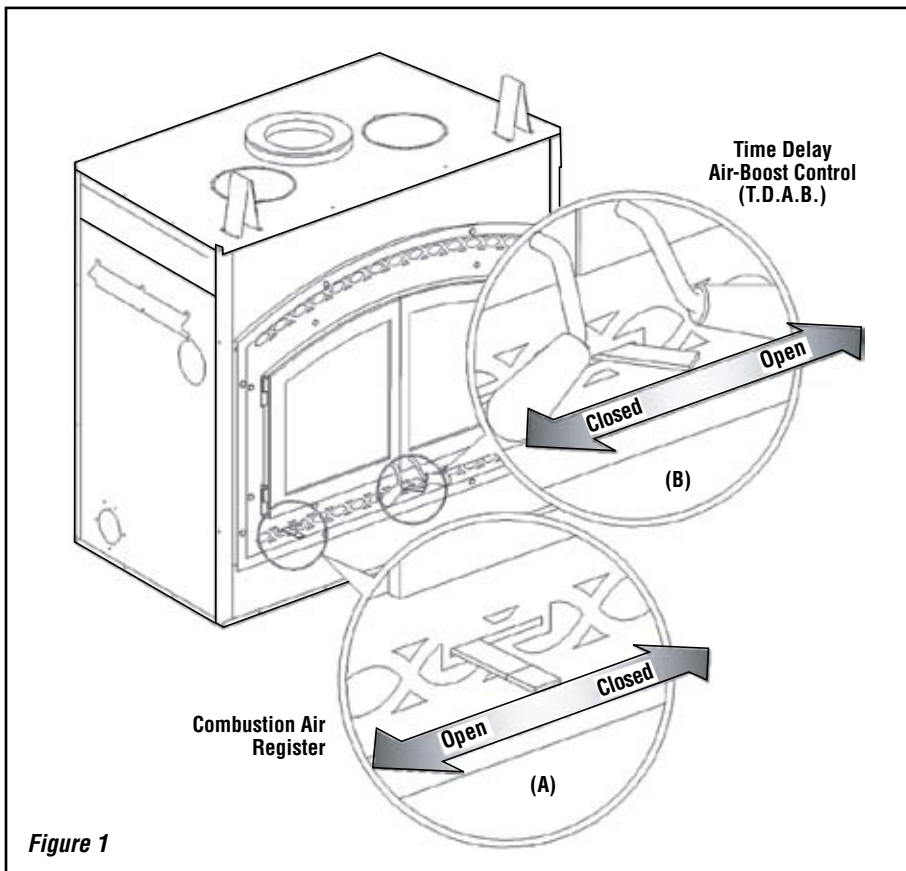

Figure 1

### Accelerated Combustion

The maximum heat output for the Montecito Estate is achieved by burning with the door closed and the combustion air opened and pulled out. Through this method, the Montecito Estate can produce up to 80,000 BTU of heat per hour.

However, it will be necessary to reload with wood every one or two hours. This is the least efficient method of burning the Montecito Estate .

Use caution when firing with the combustion air control wide open. Only burn cord wood in this manner. Small dry pieces of softwood and construction scraps will burn very intensely using this method and may damage the firebox.

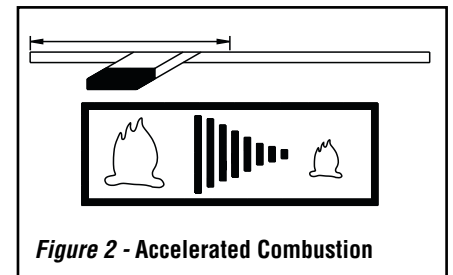

Figure 2 - Accelerated Combustion

### Medium Combustion

This is the recommended mode of operating the Montecito Estate and should be the one normally used since it will deposit the least amount of creosote on the glass and in the chimney. The combustion air control must be 3/4 closed. The precise setting will depend on many factors, including chimney length and the moisture content of the wood.

For instance, a long chimney will necessitate closing the damper more. To obtain the proper combustion, close the damper completely, then open it about 1/4" to 1/2". Three medium size pieces of cord wood-burning on a bed of hot coals will generate an approximate heat output will of 35,000 BTU per hour and the loading time will be about every 3-4 hours. Softwoods may be burned using this method but the combustion time will be substantially reduced.

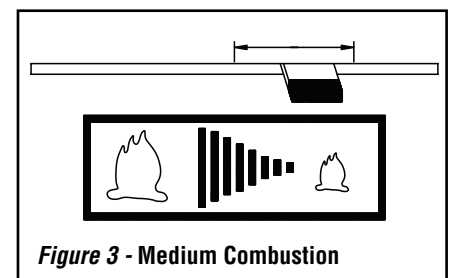
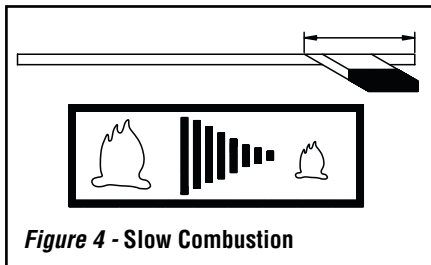

Figure 3 - Medium Combustion

## Slow Combustion

When the air combustion control is completely closed, the fireplace is in a slow combustion phase. If the hearth is hot enough, slow combustion will not extinguish the fire, but there will be a noticeable change in the flame pattern. The flames will be slow and may appear dirty if the wood is too wet (moisture content of 20% and more).

Do not allow the wood to burn without flame, since this will produce excessive creosote in the unit. Creosote may accumulate on the glass door. This method of burning should be used only after operating the Montecito Estate™ with the air control opened to produce a hot fire for about an hour or at medium pace for at least three (3) hours. Slow combustion can be used at night in order to reduce the heat output and to prolong the burn. The loading time will be between 6-8 hours and at this combustion rate, the level of BTU's is at its lowest.



## Building a Fire

- To start a fire, place several crumpled up balls of newspaper in the firebox. Place small dry pieces of kindling on top of the paper, criss-crossing the kindling so that there are air spaces in between. The kindling should be placed at the center of the firebox so as to allow for sufficient air circulation.
- Adjust the primary air control and start the time delayed air-boost system by pushing the register towards the right. Light the newspaper. Leave the doors partially opened to facilitate the start-up.
- Once kindling fire is well established, cord wood can be added. You may set the primary air control to the desired level (see *Primary Air Combustion Control* and *Air Boost Controls* section for proper operation of the air controls).
- Set the primary control to the desired burn level. The fireplace will automatically go to that level after the fire is fully established and the air boost is closed.

The unit will burn best with 2-3 pieces of cord wood spaced 1 to 2 inches apart and allowing air to get under the fuel. Criss-crossing or arranging the fuel so that air can get underneath will help the fire to get started easily. The unit should be operated with the air control fully open long enough to get the cord wood well ignited.

## REFUELING FOR BEST PERFORMANCE

To reload the Montecito Estate at the end of a combustion cycle, when no flame is visible and there are only ashes left:

- Completely open the air control level and the T.D.A.B. (Time Delay Air Boost) level. See *Figure 1*.
- Open the doors about 1" and wait 5 seconds until the air flow has stabilized. Then open the doors completely, put the logs in and close the doors.
- Set the air control to the desired burn level. The T.D.A.B will close by itself progressively.

To reload the Montecito Estate when the fireplace is still hot with a few visible flames:

- Open the air control completely. The T.D.A.B can be set to a lower setting in order to facilitate lighting.
- Open the doors about 1" and wait 5 seconds until the air flow has stabilized. Then open the doors completely, put the logs in and close the doors.
- Set the air control to the desired burn level.

## Notes:

- For spectacular fire and optimization of the fireplace efficiency, we recommend that the wood load be placed as far back as possible.*
- It may be necessary to turn off any blower(s) in operation during the refueling process in order to minimize smoking in the room. It is recommended to wait 15 to 30 minutes before turning the blower(s) back on to ensure successful rekindling.*

## SMOKING – CAUSES AND TROUBLESHOOTING

To reduce the likelihood of smoke coming into the room when opening the door, set the combustion air controls to the left ("Accelerated Combustion") before opening the door. Your fireplace has been designed and tested to provide smoke free operation.

As the fire burns, air goes up the chimney. This air must be replaced through the outside air duct. When operating the Montecito Estate, open a nearby window temporarily to check if there is adequate air supply replacement. Occasionally, there may be a small amount of smoking upon lighting the fire, until the chimney heats up but this should not last. If the fireplace continues to smoke it is probably for one of the following reasons:

### A. The doors are partially opened

When you open the doors, open them completely.

### B. Negative pressure in the house

### C. Fans operating (e.g.: range hood)

These fans draw air out of the house and may actually cause a negative pressure in the house. Turn off all fans and open a nearby window to determine if this is the cause of the problem.

### D. Wet wood

Wet or tarred wood will smoulder and smoke instead of burn properly.

### E. Dirty or blocked chimney

Check to make sure the chimney is clear and clean.

### F. Chimney not long enough

The minimum chimney height is 12 feet not including the fireplace height. The chimney must extend at least three (3) feet (915 mm) above its point of contact with the roof and at least two (2) feet (610 mm) higher than any roof or wall within ten (10) feet (3 m) of it. When installed with offsets, the minimum chimney height is 15 feet. Additional height will increase draft and will decrease the tendency to smoke.

### G. Poor chimney draft

With no fire, there should be sufficient draft to exhaust cigarette smoke introduced under the baffle. Chimneys installed against an outside wall without protection may generate back draft problems which will cause start-up problems. To prevent this, open a nearby window; roll up a piece of paper, light it and hold it in the upper part of the firebox to warm up the chimney. Wait until the draft is sufficient, then start the fire.

## IMPORTANT CAUTIONS

- A. Do not block the hot air vents to the fireplace as this will cause the fireplace to overheat.
- B. Never use gasoline, kerosene, charcoal lighter fluid or similar liquids to start or rekindle a fire in this fireplace. Keep all such liquids well away from the fireplace at all times.
- C. Do not burn coal. The sulphur in coal will corrode the firebox.
- D. Do not burn driftwood which has been in the ocean or salt water. The salt will corrode the firebox and chimney.
- E. Do not burn wood in the area in front of the grate.
- F. Do not abuse the unit by burning paper, or cardboard or construction material such as pressed wood, plywood or lumber. Wood protectors, metallic paper, coal, plastic, waste, sulphur and/or oil will damage the fireplace.
- G. Do not allow the wood to smoulder or burn without flame, since this will produce excessive creosote in the unit.

## MAINTAINING YOUR MONTECITO ESTATE

### Creosote

When wood is burned slowly without a flame, it produces tar and other organic vapors which combine with expelled moisture to form a black deposit called creosote which accumulates on the flue lining. When ignited, this creosote makes an extremely hot fire. If the creosote accumulation is large, a creosote fire in the chimney can damage the chimney and overheat the surrounding wood framing. Creosote formation in a chimney can be minimized by making sure there is always visible flame burning, avoid smoldering fires and by proper refueling techniques.

### Chimney Maintenance

Regular chimney inspection and maintenance combined with proper operation will prevent chimney fires. Keep your chimney clean. Do not allow more than 1/16" creosote build up in your chimney. The amount of creosote will depend on variables such as frequency of use and type of fire. We recommend that you:

- A. Initially inspect the chimney system weekly. From this, you will learn how often it will be necessary to clean your chimney.
- B. Have your chimney cleaned by a qualified chimney sweep. If you wish to clean it yourself, we recommend using a stiff plastic or non-metallic brush. If a metal brush is used, its size should be slightly smaller than the flue to avoid damaging the chimney. Do not use a brush that will scratch the stainless steel interior of the chimney.

- C. Do not expect chemical cleaners to keep your chimney clean. The rain cap can be removed for inspection and/or cleaning of the chimney.

### Dealing With a Chimney Fire

Regular chimney maintenance and inspection can prevent chimney fires. If you have a chimney fire, follow these steps:

1. **IMPORTANT:** Close the fireplace door and the combustion air controls; this will stifle the fire.
2. Alert your family of the possible danger.
3. If you require assistance, alert your fire department.
4. If possible, use a dry chemical fire extinguisher, baking soda or sand to control the fire. Do not use water as it may cause a dangerous steam explosion.
5. Ensure that sparks and hot embers coming out of the chimney are not igniting the roof.
6. Do not use the fireplace again until your chimney and fireplace have been inspected by a qualified chimney sweep or a fire department inspector.

## REFRACTORY REPLACEMENT

The intense heat of the fire will normally cause hairline cracks in the refractory brick. These cracks can be minimized by proper curing as described in section *First Fires*. They will not normally diminish the effectiveness of the refractory brick. If large cracks develop, then the refractory should be replaced. To replace the refractory bricks, follow these steps:

## DOOR FRAME FINISH CARE

Use a glass cleaner and a soft cloth to polish the casing. Do not use abrasives such as steel wool, steel pads or an abrasive polish for they may scratch the frame's finish.

## DISPOSING OF ASHES

Remove ashes only when the fire is out and the ashes are cold (24 to 48 hours after the fire is out).

## WARNING

**When cleaning the fireplace, the ashes should be placed in a metal container with a tight fitting lid. The closed container of ashes should be placed on a non-combustible floor or on the ground outside the house, pending final disposal. If the ashes are disposed of by burial in soil or otherwise locally dispersed, they should be retained in the closed container until all cinders have thoroughly cooled.**

1. Remove the side refractory brackets (6)
2. Remove the front refractory bricks (3)
3. Remove the bottom refractory brick (4)
4. Remove the left side refractory bricks (5)
5. Remove the right side refractory bricks (2)
6. Remove the back refractory brick (1)
7. Remove the deflectors (7) above the tubes (Can be removed without removing other bricks for chimney cleaning)

To install the new refractory bricks, follow the above steps in reverse.

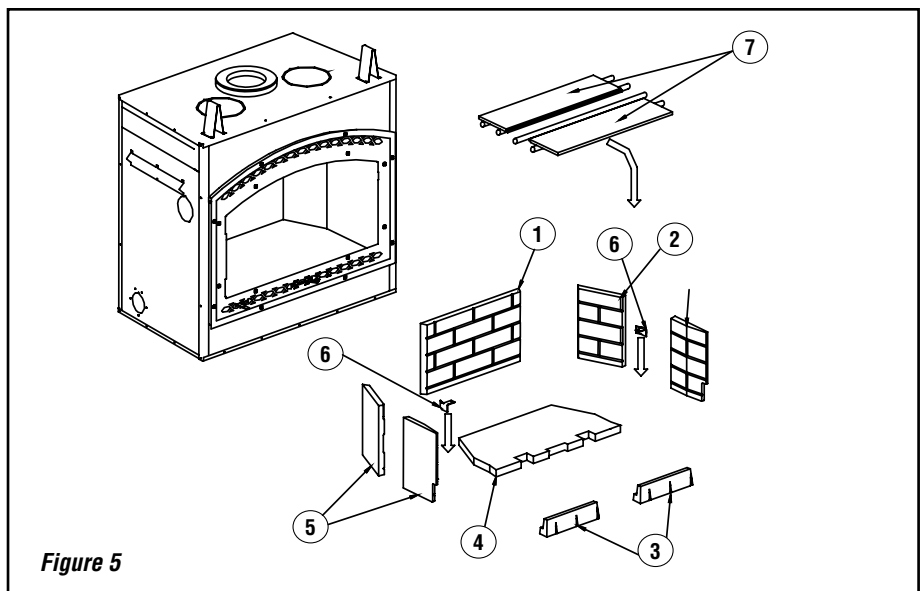

Figure 5

## DOOR INSTALLATION

The doors must be put in place only when the installation of the Montecito Estate™ is completed. All you have to do is fit the male part of the hinge, already on the door, to the female part, which is on the fireplace. To remove the doors, simply pull them up from the hinges. The door adjustment has been set at the factory. If the fit is still not perfect, you can adjust the door using the hinge screws (See *Figure 7-1*)

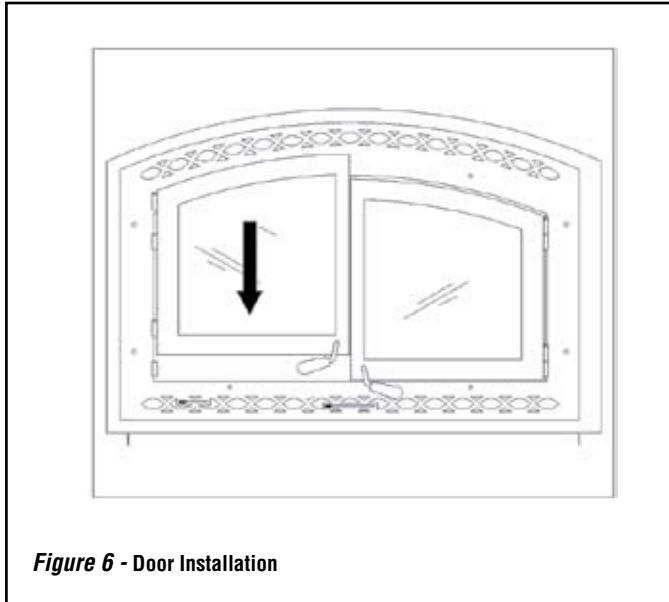

Figure 6 - Door Installation

## DOOR ADJUSTMENT

The doors may need to be adjusted to be completely airtight. The gaskets' air-tightness can be adjusted using the adjustment screw located on the right side of the fireplace facade (An Allen key #1/8 – not supplied - will be necessary for this adjustment) (see *Figure 7-2*).

### Checking Door Seal

A one-inch strip of paper may be used to perform a test of the integrity of the door seal. Close the door on the paper in at least eight points. It is normal to feel only a slight amount of friction. The door gasket does not need to be “tight” in all areas, since a small amount of leakage is not hazardous or detrimental to the performance of your fireplace.

## ⚠ WARNINGS

- Use only a Lennox Hearth Products glass doors, specifically designed for the Montecito Estate fireplace.
- The fireplace cannot be operated without a door. Consult your dealer to select the correct door model.
- Important! To assure proper alignment of glass doors: Install this fireplace in a square and plumb condition, using shims as necessary at sides and/or bottom.

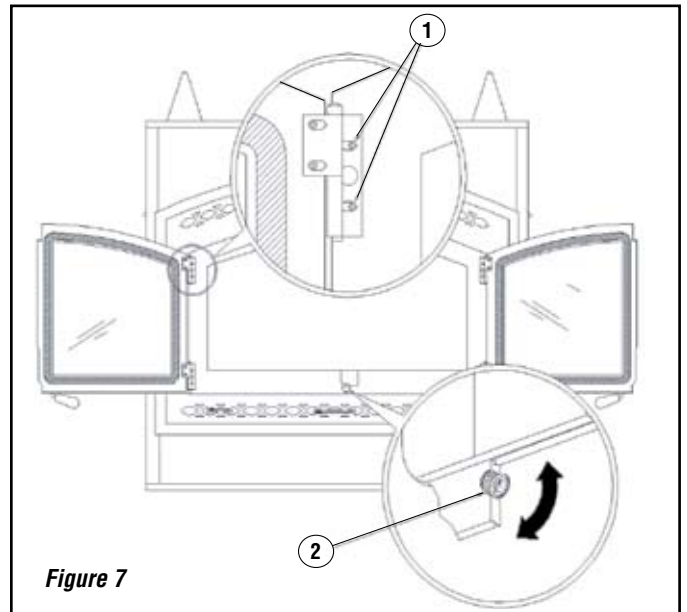

Figure 7

## GLASS CARE

### Glass Replacement

The glass used for the Montecito Estate is a high temperature ceramic glass (1,400° F). If the glass breaks or cracks, it must be replaced with an identical ceramic glass. Tempered glass or ordinary glass will not withstand the high temperatures of the Montecito Estate. Replacement glass should be purchased from a Security Chimneys International dealer (see “Replacement Parts” on *Page 22*).

Do not operate the unit with cracked or broken glass.

### Glass Cleaning

The Montecito Estate is designed to keep the glass clean under normal operating conditions. If the Montecito Estate is operated continuously with the combustion air controls closed, the glass will tend to get dirty unless the fuel, firebox and glass are maintained at hot temperatures (see section *Refueling For Best Performance*). To clean the glass, there are a number of specially designed cleaners to remove creosote. Your authorized Lennox Dealer can recommend a suitable cleaner. Regular household glass cleaners will not clean creosote. Do not use abrasives such as steel pads, steel wool or oven cleaner as they will scratch the glass.

### Gasket Replacement

Remove the doors from the unit (see section *Door Installation*) and lay them on a clean nonabrasive surface. To replace the gasket, first remove all of the old gasket and gasket cement. Make sure that the surface is totally clean before applying new cement (a high temperature silicone caulking rated at 500° F (260° C), is suitable) or adhesion problems may result. Apply gasket cement to the gasket channel and install the new gasket. This replacement part is available from your Lennox Dealer in the following dimensions:

Gasket	Part #	Length	Qty	Dimensions
Around the glass	PR-SR-1685C	61-3/4"	2	1" width x 3/16" thick
On the door frame	PR-SR-1825I	48-3/8"	2	3/4" diameter
Between the doors	PR-SR-1823J	17-5/8"	2	5/8" diameter

Table 1





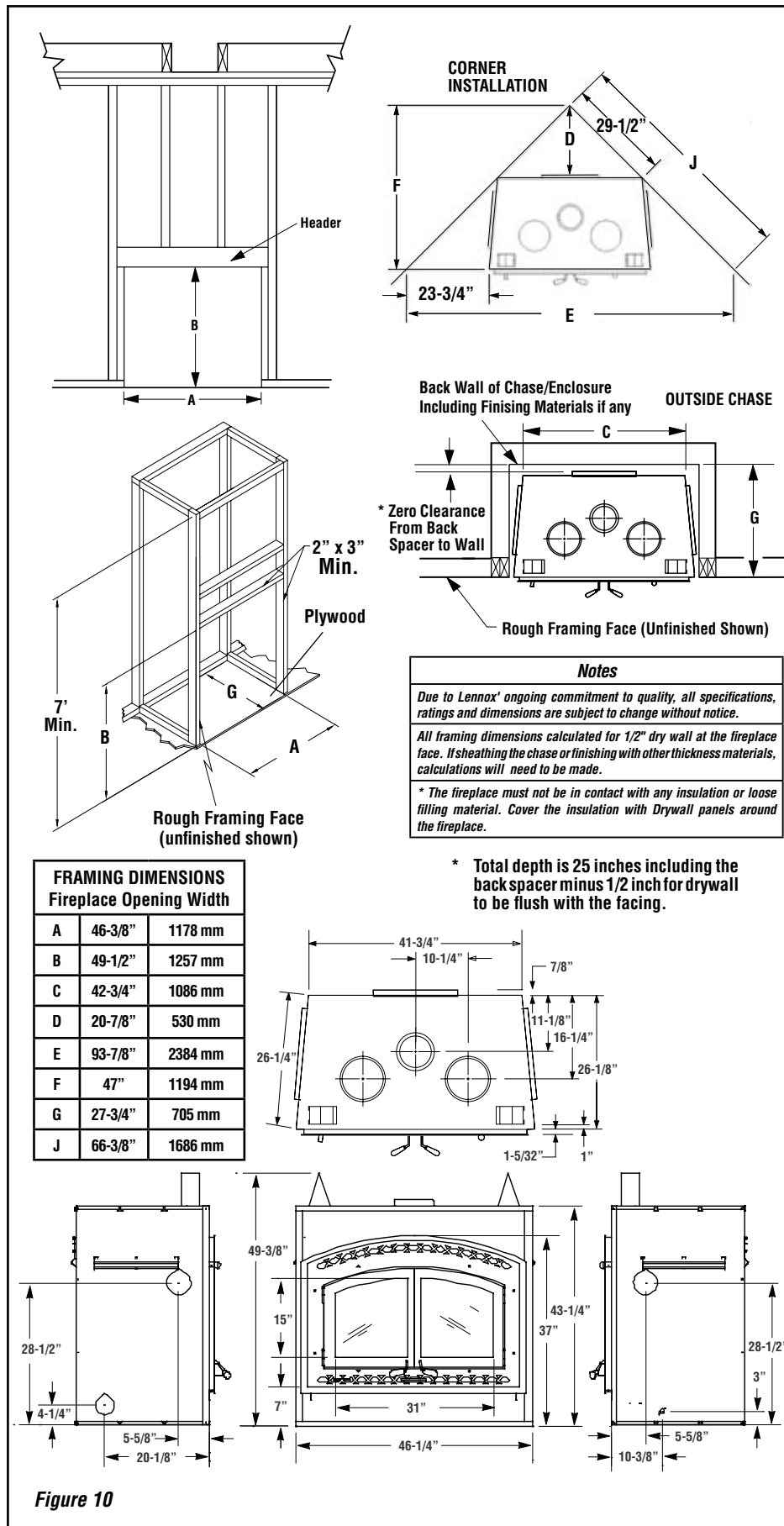

Figure 10

NOTE: DIAGRAMS & ILLUSTRATIONS ARE NOT TO SCALE.

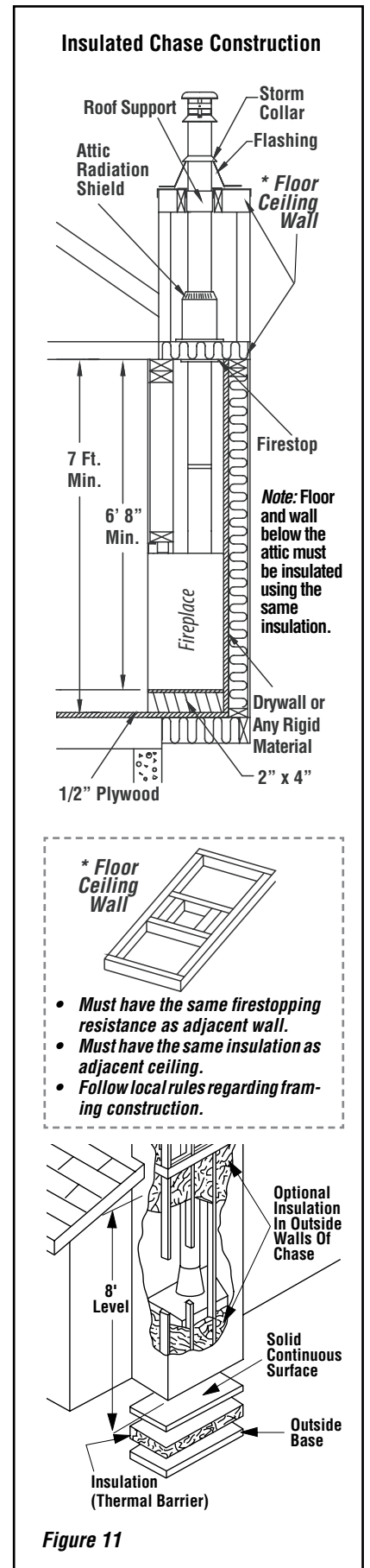

Figure 11

## FACING

### IMPORTANT

The facade must be removable once installed. The facade is designed to overlap any facing material installed on the front of the fireplace. If thicker material is installed, use the facade as a template and make sure it can be easily removed for servicing.

1. Combustible material must be installed flush with the fireplace. It may not project in front of and on the fireplace (i.e. the steel facade of the fireplace) (Figure 14).
2. Non-combustible materials such as brick, stone or ceramic tile may project in front of and onto the fireplace facing (Figure 13).

## MANTEL & FACING

The mantel must be installed at least 56" (1143 mm) above the base of the fireplace (Figure 13).

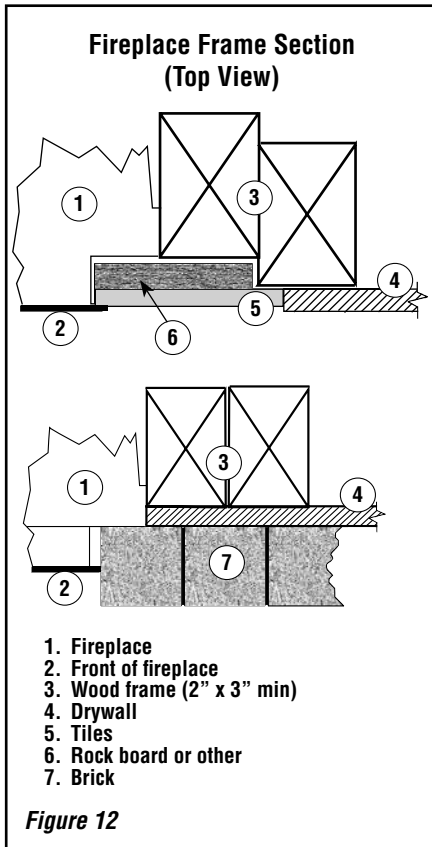

Figure 12

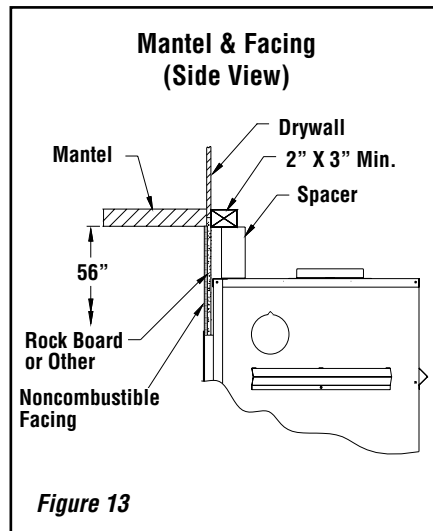

Figure 13

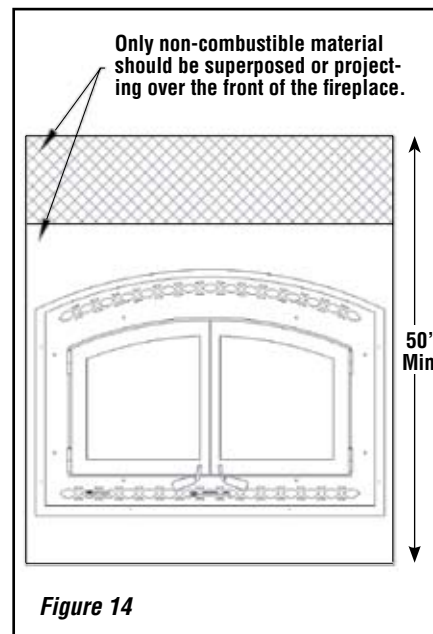

Figure 14

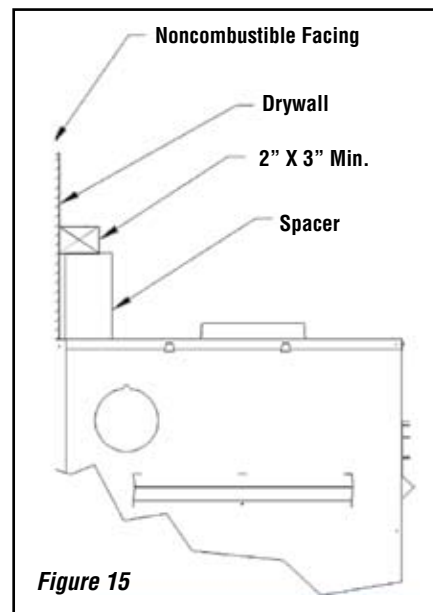

Figure 15

## Fireplace Blower

The fireplace comes equipped with a heat activated blower. It is located in the bottom of the fireplace, towards the back. It uses 120 V and must be connected to the main electrical circuit by a qualified electrician. For connection, use the electrical box supplied with the unit located on the bottom right corner of the fireplace.

If you wish to adjust the blower speed, the variable speed control (VRUW) provided must be installed in line with the wiring. Again, use a qualified electrician for installation.

If the blower requires servicing,

- 1- Remove the doors and decorative facade.
- 2- Remove the screw located below the blower motor that holds it to the back of fireplace.
- 3- Pull the blower out of the unit through the square hole located in the front bottom right corner.

## HOT AIR DUCTING INSTALLATION

The Montecito Estate™ is approved for use with a Gravity Kit:

### Gravity Kit

The gravity kit is designed for double hot air outlets and includes: (See Figure 16)

- 2 telescopic lengths 8" I.D.
- 2 90° elbows 8" I.D.
- 2 hot air outlet kits (grill and frames)
- 2 adaptors

See *Gravity Kit Accessories* on **Page 20**.

Only the blower available with the fireplace can be used with the gravity kit.

For safe installation, the gravity kit must meet the following requirements:

- Minimum height\*** 68" (1,727 mm)
- Maximum length** See **Figure 17**

\* The height of the louver must be measured from the base of the Montecito Estate to the middle point of the louver.

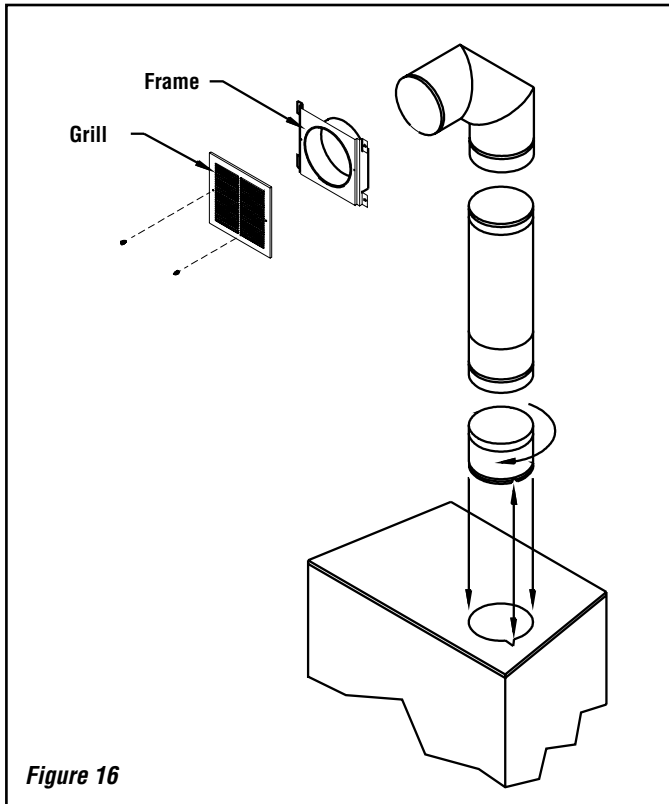

Figure 16

When installing the double outlet system, the hot air outlets can be installed in the same room as the fireplace, or one or both of the outlets can be installed in adjacent or upper rooms. Installing the ducts at different elevations will tend to exhaust more heat out of the higher outlet (Figure 17).

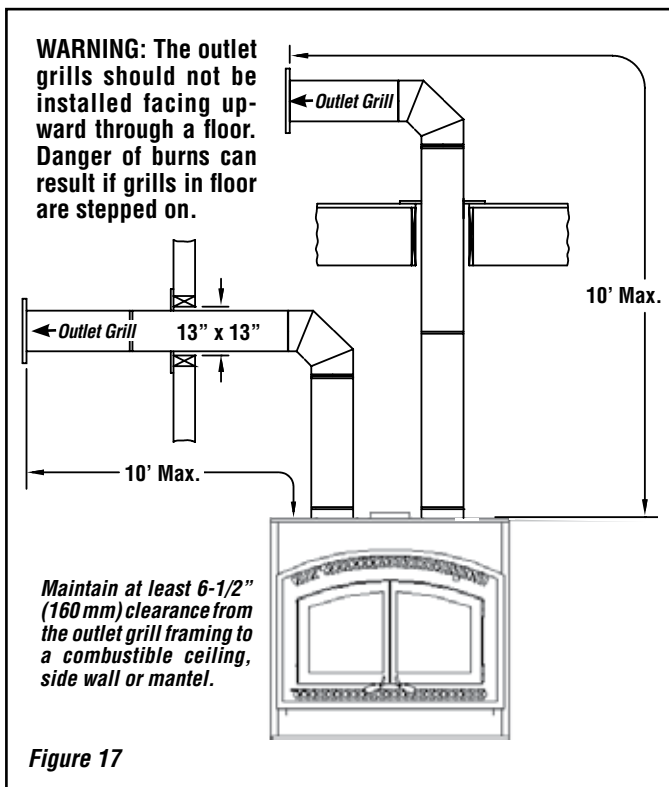

Figure 17

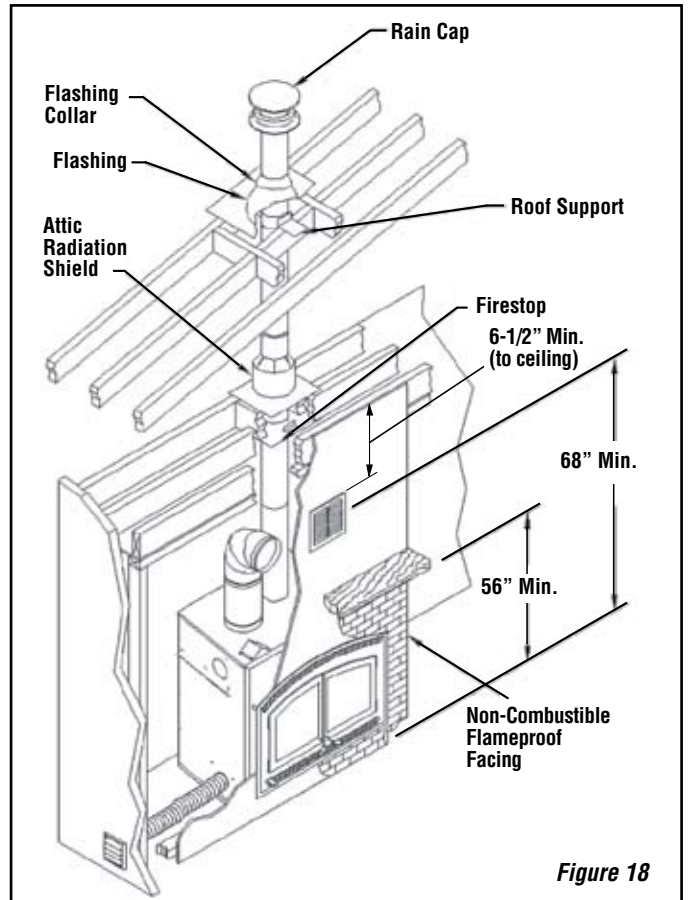

Figure 18

The duct system must be installed respecting the following:

1. Remove the plates closing up the 8" dia. holes on top of the fireplace. Then, cut the insulation in order to obtain two 8" dia. openings. Fix the adaptors on the fireplace openings by turning clockwise (Figure 16).
2. Maintain at least a 2" (50 mm) clearance between the ducts and any combustible material; the required hole size is 13" x 13" (330 mm x 330 mm).  
**Exception #1: For the grills, the framing can be 10-3/4" x 10-3/4" (275 mm x 275 mm) to provide the clearance as required by the integral spacers on the double outlet duct system.**
3. The maximum number of elbows in a run of duct is two.
4. Maintain at least 6-1/2" (160 mm) clearance from the outlet grill framing to a combustible ceiling, side wall or mantel.
5. When traversing a combustible wall or floor, a firestop must be installed at the wall or floor penetration. The hole size must be 13" x 13" (330 mm x 330 mm)
6. Do not connect the hot air ducts to a central heating system. Malfunction of the heating system's blower will cause the fireplace to overheat. A furnace duct is only single wall and not double wall as is required for the Montecito Estate™ hot air exhaust.
7. Use only Security Chimneys International grills and components as described in this manual. Other grills or registers may be too restrictive and may overheat the fireplace or ceiling.
8. Do not use insulated flexible ducts as they will overheat.
9. Do not use tees or any other components than the ones specifically listed here.
10. Never allow the ducting to pitch down as hot air will be trapped creating a fire hazard. Never route the ducting downwards.
11. The hot air outlet grills must be installed with the louvers pointing downwards in order to prevent overheating adjacent ceilings.

## OUTSIDE AIR KIT

It is mandatory to install an outside air connection to the Montecito Estate™. The following components are required and are included with the fireplace:

- Outside air kit (includes 40 inch flex that goes up to ten (10) feet long)
- 4" Adaptor for fireplace connection

### Outside Air Installation

The outside air assembly may be installed according to the following requirements:

- Duct length should be kept to a minimum. The maximum length of a 4" interior diameter (100 mm) insulated flexible duct is 20 feet (6.1 m). The duct can be extended to a maximum of 40 feet (12 m) using a 6" interior diameter (150 mm) insulated flexible duct (See note below).
- The air intake register must not be installed more than ten (10) feet (3050 mm) above the base of the fireplace.
- The fresh air must come from outside the house. The air intake must not draw air from the attic, basement or garage.
- The air intake should be installed where it is not likely to be blocked by snow or exposed to extreme wind and away from automobile exhaust fumes, gas meters and other vents.
- The duct and register may be installed above or below floor level.

Make a 4-1/4" (110 mm) hole in the outside wall of the house at the chosen location. From outside, place the outside air register in the hole (open side down) and fasten the register to the wall with screws as shown (see **Figure 19**). Slip the pipe into the insulated sleeve. Place the insulated pipe over the register tube and over the fireplace's outside air connector (see **Figure 20**). At each end, carefully pull back the insulation and plastic cover exposing the flexible pipe. Using the aluminium tape provided, wrap the tape around the joint between the flexible pipe and the air inlets. Carefully push the insulation and plastic cover back over the pipe. Using aluminium tape, fasten the plastic cover in place.

**NOTE:** We recommend not to exceed 20 feet of 4" flexible pipe. If you require a longer length we recommend that you use a 5" diameter flexible pipe for the complete run up to 30 feet and a 6" diameter pipe for a run of up to 40 feet.

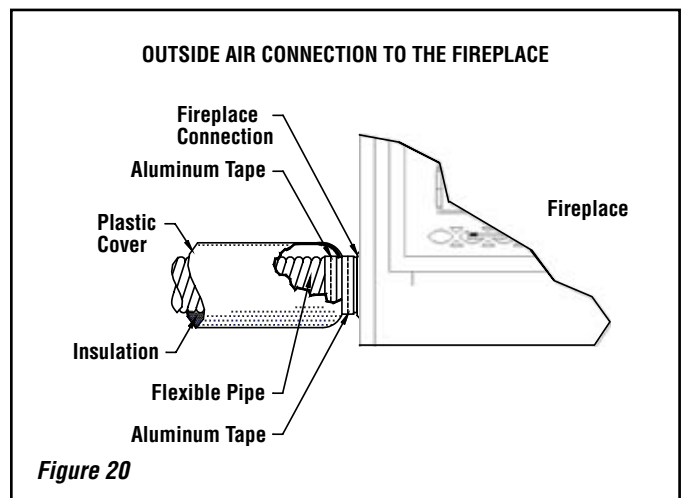
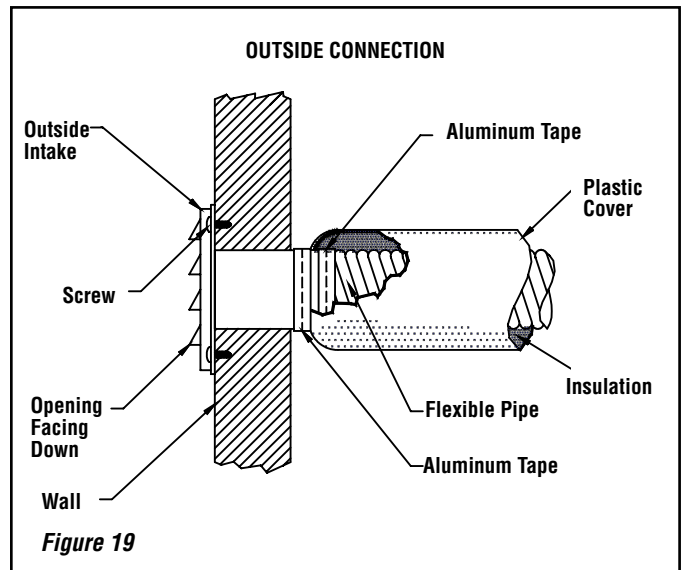

## THE CHIMNEY SYSTEM

### Chimney Installation Notes

1. If possible, install an interior chimney as it will provide better performance. In areas with continuous temperatures below 18°C (0°F), the use of an exterior chimney increases the likelihood of operating problems such as low draft, high rate of creosoting, and poor start-up characteristics. Exterior chimneys are also prone to down-drafting and flow reversal. Installations which are located on lower floors in the house, such as in a basement, in combination with an outside chimney, are especially prone to flow reversal.
2. The fireplace model MONTEST may be installed only with Security Chimneys International Ltd 7" dia. chimney systems model Secure Temp™ S2100+ / Nova Temp™ HT6000 / Secure Temp GX (U.S. only) or ACBI.
3. A chimney venting a fireplace shall not vent any other appliance.
4. The minimum chimney height is 12 feet (3.7 m) excluding the fireplace.
5. All chimney installations must include at least one support in order to be able to take any lateral load. The maximum chimney length that can be supported by the fireplace is nine (9) feet (2.75 m) for Secure Temp S2100+ / Nova Temp HT6000+ / Secure Temp GX and 26 feet (8m) for ACBI chimney. In altitude, add 18" (450 mm) to the chimney for every 2,000 feet (600 m) above sea level.
6. The chimney must extend at least three (3) feet (915 mm) above its point of contact with the roof and at least two (2) feet (610 mm) higher than any wall, roof or building within ten (10) feet (3 m) of it (**Figure 21**).
7. If the chimney extends higher than five (5) feet (1,500 mm) above its point of contact with the roof, it must be secured using a roof brace.
8. A rain cap must be installed on top of the chimney. Failure to install a rain cap may cause corrosion problems.
9. Cut and frame square holes in all floors, ceilings, and roof that the chimney will go through to provide a 2" (50 mm) clearance between the chimney and any combustible materials. Do not fill this 2" space with insulation or any other combustible material.
10. Portions of the chimney which may extend through accessible spaces must be enclosed to avoid contact with combustible materials or damage to the chimney.
11. When offsets are used, the pipe may not penetrate a ceiling or floor unless it is running vertical (no 30° offsets).

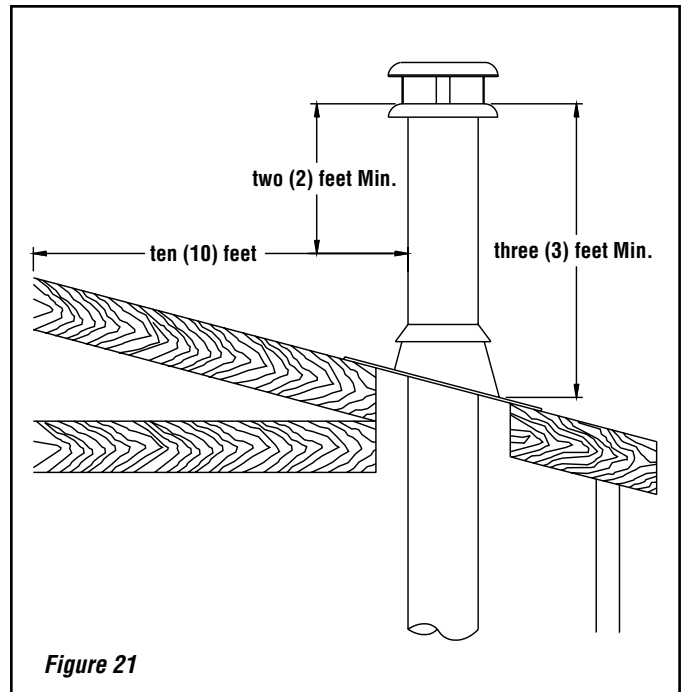

## CHIMNEY INSTALLATION INSTRUCTIONS

1. Cut and frame the holes in the ceiling, floor and roof where the chimney will pass (see **Figure 22**). Use a plumb bob to line up the center of the holes. The sizes are indicated in **Table 2** for the floor and ceiling holes and **Table 3** (Page 15) for the roof holes.

CHIMNEY MODEL	SQUARE HOLE SIZE OPENING
Secure Temp™ S2100+ Nova Temp™ HT6000+ Secure Temp GX	15 in (380 mm)
ACBI: Ceiling (1" clearance) Wall	15 in (380 mm) 17 in (432 mm)

*Note: See Table 3 for Sloped Roof Framing*  
**Table 2 - Flat Roof Framing**

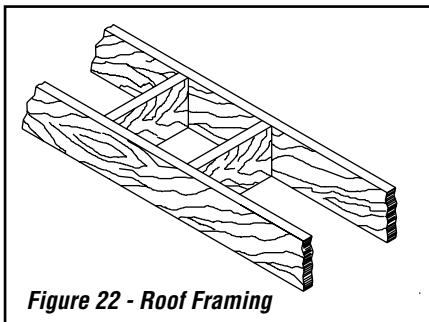

**Figure 22 - Roof Framing**

From below, install a firestop in each ceiling/floor separation through which the chimney will pass. At the attic level, install an attic radiation shield from above (**Figures 23a & 23b**).

2. For Secure Temp S2100+ / Nova Temp HT6000+ / Secure Temp GX chimneys, place the first chimney length on the fireplace. To lock it in place, turn 1/4 of a turn clockwise. With the ACBI chimney, you must use a starter section before installing the first chimney length (**Figure 24**). Continue installing chimney lengths making sure to lock each length in place.
3. Every time the chimney passes through a ceiling or a wall, install the appropriate firestop. When you reach the desired height, install the roof support (Refer to instructions included with the support). For an ACBI chimney use an universal support AC10SU.
4. Put the roof flashing in place and seal the joint between the roof and the flashing with roofing pitch (see **Figures 25 & 26**). For sloping roofs, place the flashing under the upper shingles and on top of the lower shingles. Nail the flashing to the roof, using roofing nails.
5. Place the storm collar over the flashing, and tighten it with the bolt supplied. Finally, seal the joint between the storm collar and the chimney, using silicone caulking.
6. Install the chimney cap.

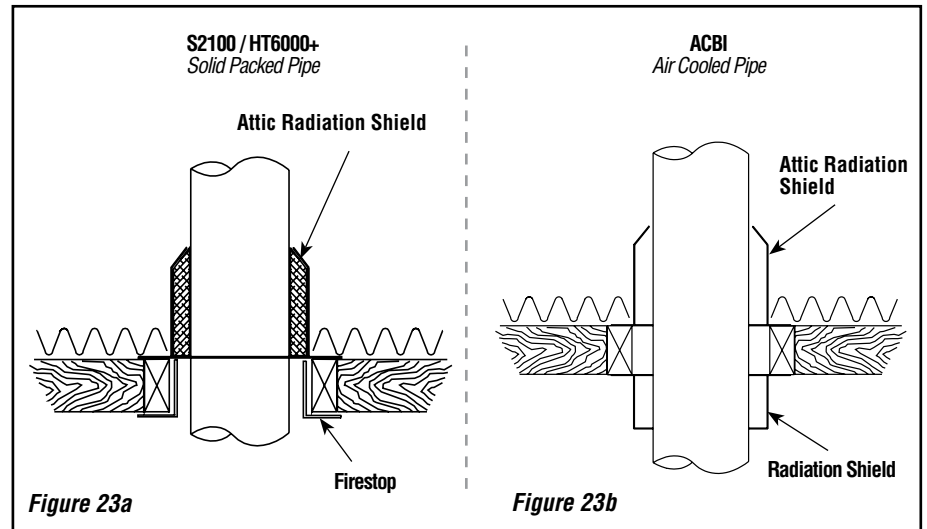
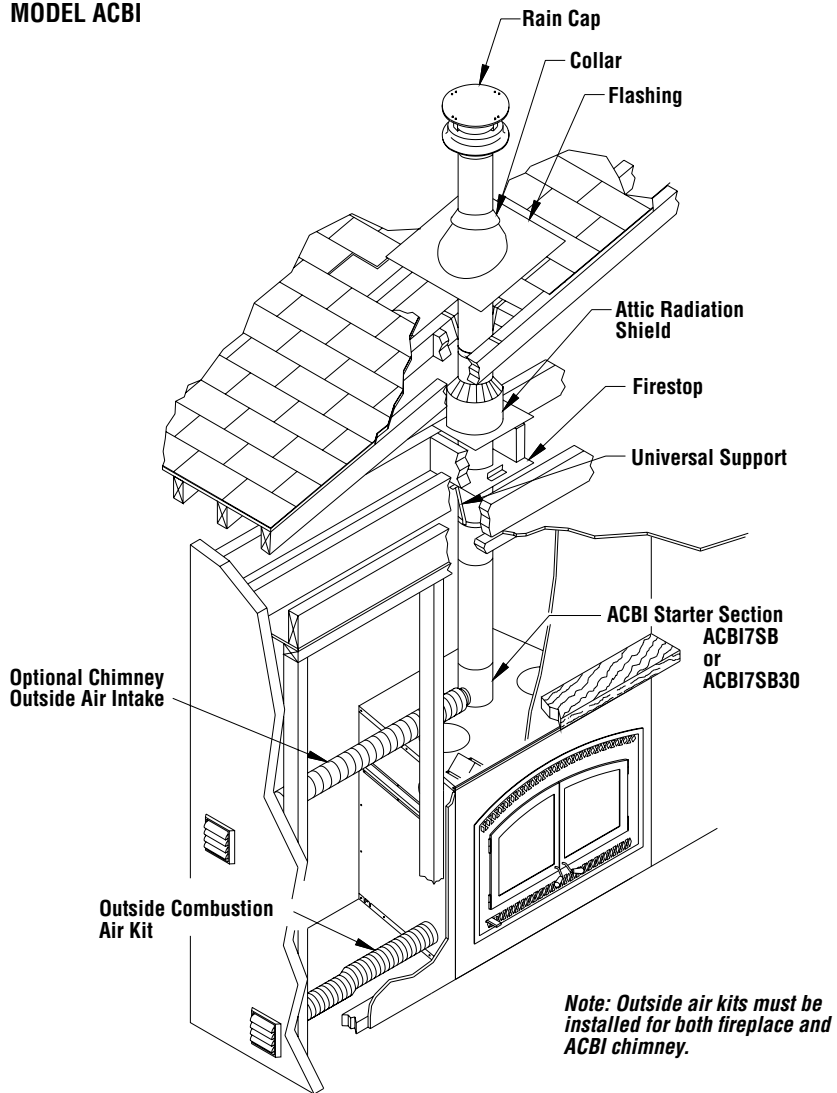

**Figure 23a**

**Figure 23b**

## CHIMNEY INSTALLATION

### MODEL ACBI



**Figure 24**

NOTE: DIAGRAMS & ILLUSTRATIONS ARE NOT TO SCALE.

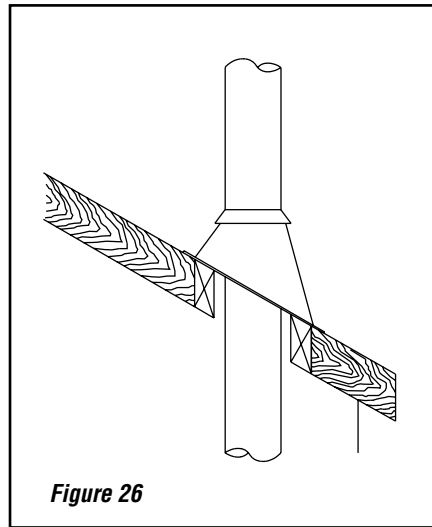
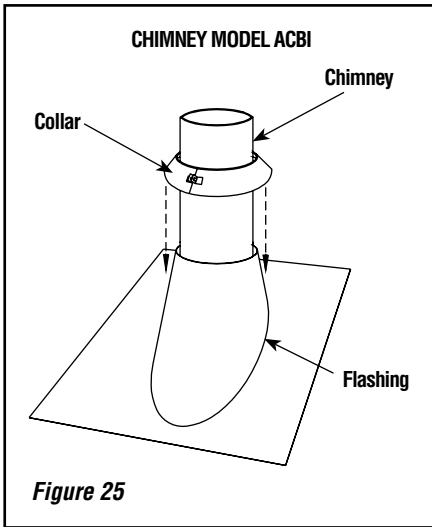

Roof Down Slope Hole Size		
DEGREE OF SLOPE	Secure Temp™ S2100+ Nova Temp™ HT6000+ Secure Temp GX	ACBI
Roof Pitch	7"	7"
0 *	15" (380 mm)	15" (380 mm)
2/12	15-3/8" (390 mm)	15-3/8" (390 mm)
4/12	16-1/8" (410 mm)	16-1/8" (410 mm)
6/12	16-7/8" (430 mm)	16-7/8" (430 mm)
8/12	18-1/4" (465 mm)	18-1/4" (465 mm)
10/12	19-5/8" (500 mm)	19-5/8" (500 mm)
12/12	21-3/8" (545 mm)	21-3/8" (545 mm)

**Table 3** \* Cross Slope Hole Size

### OFFSET CHIMNEY INSTALLATION

After reaching the location requiring the elbow, proceed as follows. The minimum chimney height when using elbows is:

Minimum Chimney Height When Using Elbows	
Fireplace Model	MONTEST
Chimney Model	Secure Temp S-2100+ / Nova Temp HT6000+ / Secure Temp GX / ACBI
Vertical Installation	3.66 m (12')
Two (2) Elbows	4.57 m (15')
Four (4) Elbows	5.18 m (17')

**Table 4**

**Note:** Must return to vertical before penetrating ceiling or floor.

After reaching the location requiring the elbow, proceed as follows:

#### Secure Temp S2100+ / Nova Temp HT6000+ / Secure Temp GX Chimneys

1. Install the first elbow; turn it in the required direction. Fasten it to the chimney with the three (3) 1/2" (12 mm) metal screws provided with the elbow.
2. Install the necessary chimney lengths to achieve the required offset. Lock the chimney lengths together: it is recommended to use three (3) 1/2" (12 mm) screws. If the offset length is made of two (2) chimney lengths or more, use an offset support halfway up the offset. If penetrating a wall, install a wall radiation shield (see **Figures 29 & 30**).
3. Use another elbow to turn the chimney vertically. Secure the elbow, using three (3) 1/2" (12 mm) screws (provided with the elbow).
4. Use a plumb bob to line up the center of the hole. Cut a hole for the chimney in the ceiling/floor. Frame this hole as described previously (refer to *Chimney Installation Instructions on Page 14*).
5. From below, install a firestop (See **Figure 23a**).
6. A support (XST+ or XSO+) must be used on the first 15' section (5 m).
7. Continue with the regular installation.

#### ACBI Chimney

1. Install the first elbow. Turn it in the required direction. To lock it in place, turn 1/8 of a turn. Fasten the straps attached to the elbow to the surrounding frame, using nails or drywall screws (**Figure 28**).
2. Install the necessary chimney lengths to achieve the required offset. Lock the chimney lengths together. If penetrating a wall, use a wall radiation shield.
3. Use another elbow to turn the chimney vertically. Lock it to the chimney. Fasten the straps attached to the elbow to the surrounding framing using nails or drywall screws.
4. Use a plumb bob to line up the center of the hole. Cut a hole for the chimney in the ceiling. Frame this hole as described previously.
5. From below, install a firestop (see **Figure 23b**).
6. Continue with the regular installation.

### Offset Dimensions

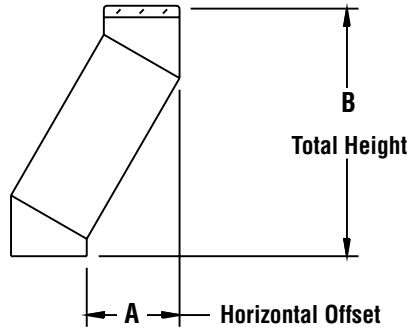

Chimney	Elbow	Offset & Height	Two Lengths Between Elbows									
			8"	12"	18"	24"	36"	8" & 36"	12" & 36"	18" & 36"	24" & 36"	36" & 36"
GX S2100+ HT6000+ 7"	15°	A	3" (76 mm)	4-1/4" (108 mm)	5-3/4" (146 mm)	7-1/4" (184 mm)	10-1/4" (260 mm)	12-1/4" (311 mm)	13-1/4" (337 mm)	14-3/4" (375 mm)	16-1/4" (413 mm)	19-1/2" (495 mm)
		B	20-3/4" (527 mm)	24-1/4" (616 mm)	29-1/2" (749 mm)	34-3/4" (883 mm)	45" (1143 mm)	51-1/4" (1302 mm)	54-3/4" (1391 mm)	60" (1524 mm)	65-1/4" (1657 mm)	75-1/2" (1918 mm)
	30°	A	7-1/2" (191 mm)	9-1/2" (241 mm)	12-1/2" (318 mm)	15-1/2" (394 mm)	21-1/2" (546 mm)	25" (635 mm)	27" (686 mm)	30" (762 mm)	33" (838 mm)	39" (991 mm)
		B	16-1/2" (419 mm)	20-1/4" (514 mm)	26-1/4" (667 mm)	32" (813 mm)	43-1/2" (1105 mm)	50-1/2" (1283 mm)	54-1/4" (1378 mm)	60" (1524 mm)	65-3/4" (1670 mm)	77-1/2" (1969 mm)
	45° Canada Only	A	10" (254 mm)	12-3/4" (324 mm)	17" (432 mm)	21-1/4" (540 mm)	29-3/4" (755 mm)	34-11/32" (872 mm)	37-5/32" (949 mm)	41-13/32" (1052 mm)	45-21/32" (1160 mm)	54-1/8" (1375 mm)
		B	17-9/16" (446 mm)	20-7/16" (519 mm)	24-5/8" (625 mm)	28-7/8" (733 mm)	37-3/8" (949 mm)	42" (1067 mm)	44-3/4" (1137 mm)	49" (1245 mm)	59-9/32" (1353 mm)	61-3/4" (1568 mm)

Chimney	Elbow	Offset & Height	One Length Between Elbows					Two Lengths Between Elbows				
			---	12"	18"	36"	48"	---	12" & 48"	18" & 48"	36" & 48"	48" & 48"
ACBI 7"	15°	A	---	5-1/2" (140 mm)	7" (178 mm)	11-1/2" (292 mm)	14-3/4" (375 mm)	---	17-1/2" (445 mm)	19" (483 mm)	23-5/8" (600 mm)	26-3/4" (679 mm)
		B	---	32-1/4" (819 mm)	38" (965 mm)	55-1/2" (1410 mm)	67" (1702 mm)	---	77-1/8" (1959 mm)	82-7/8" (2105 mm)	100-1/4" (2318 mm)	111-1/8" (2823 mm)
	30°	A	---	10-1/2" (267 mm)	13-1/2" (343 mm)	22-1/2" (543 mm)	28-1/2" (724 mm)	---	33-3/4" (857 mm)	36-3/4" (933 mm)	45-3/4" (1162 mm)	51-3/4" (1314 mm)
		B	---	30-1/8" (765 mm)	35-3/8" (899 mm)	51" (1295 mm)	61-3/8" (1559 mm)	---	70-1/2" (1791 mm)	75-5/8" (1921 mm)	91-1/4" (2318 mm)	101-5/8" (2581 mm)

Note: With the ACBI chimney, a starting length of 6" high must be used on top of the fireplace before installing.

Figure 27



### OFFSET CHIMNEY INSTALLATION

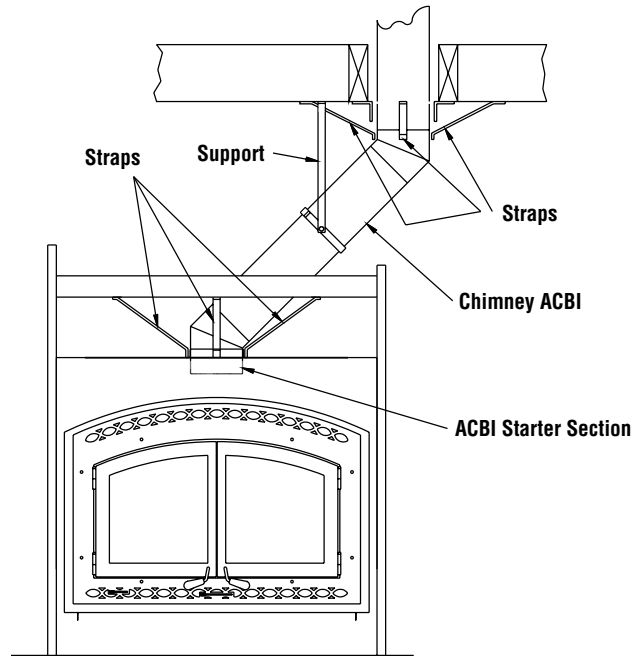
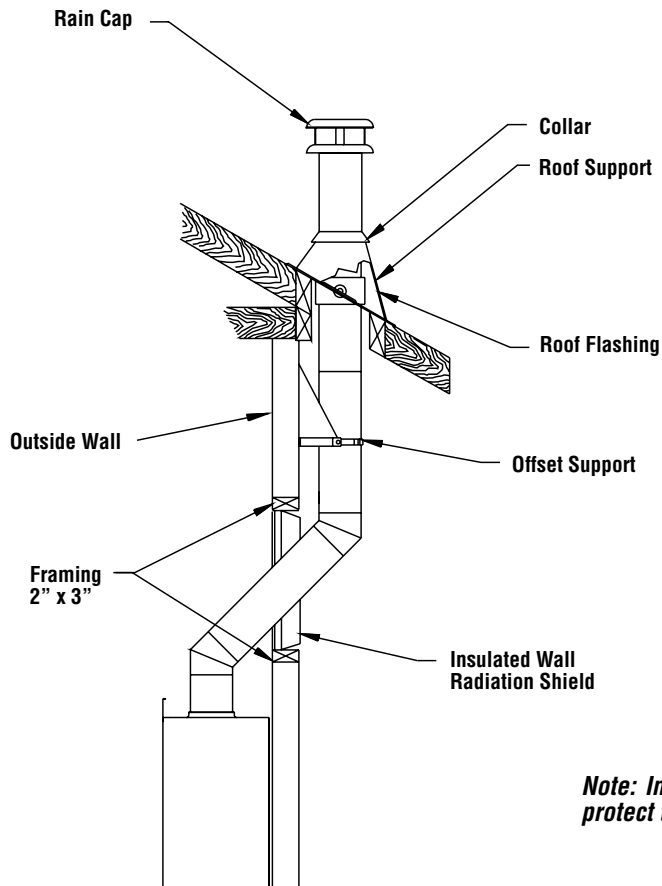

Figure 28

### OFFSET CHIMNEY INSTALLATION WITH WALL PENETRATION



*Note: In cold areas it is recommended to protect the chimney in a insulated chase.*

Figure 29

## ANGLED WALL RADIATION SHIELD (XRSMI30 and AC10RSMI30)

When traversing a combustible wall with the chimney at a 30° or 45° angle, an angled firestop or wall radiation shield must be installed. Only one is required.

**Note:** 45° angle for Canada only (XRSMI45).

In cold climate locations (climates where temperatures will fall below 32° F / 0° C), we recommend that you use the insulated wall radiation shield since it will maintain the home's thermal barrier.

XRSMI30 and AC10RSMI30 (XRSMI45 - Canada Only)		
Chimney Model (7" dia).	Angle	Hole Size
Secure Temp™ S2100+ Nova Temp™ HT6000+ Secure Temp GX (US only)	30°	15" x 38-1/4" (380 mm x 972 mm)
Secure Temp S2100+ Nova Temp HT6000+	45° Canada only	15" x 25-7/8" (380 mm x 657 mm)
ACBI	30°	17 x 42-1/2" (432 mm x 1080 mm)

**Table 5**

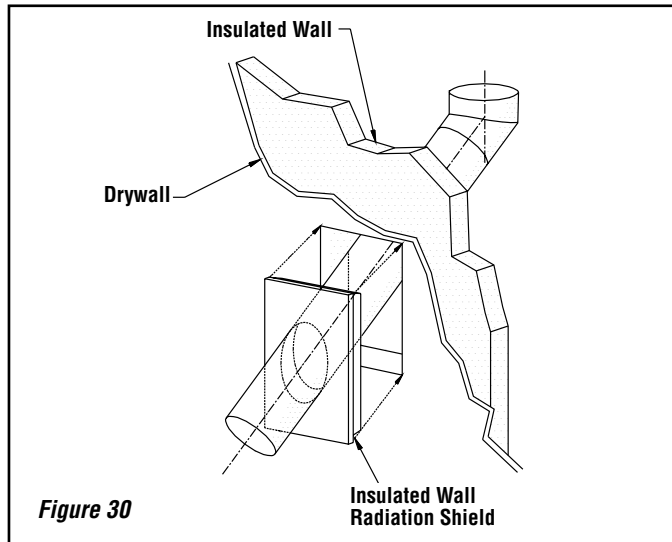

## CHIMNEY SUPPORT INSTALLATION

### Universal Roof Support

This support has three possible uses:

1. For Secure Temp S2100+ / Nova Temp HT6000+ / Secure Temp GX, it must be used on a roof to support the chimney.
2. It may be used on a floor, ceiling or roof above an offset to support the chimney above the offset.
3. It may be used on a floor, ceiling or roof as a supplementary support when the chimney height exceeds 15 feet (4.6 m).

**Table 6** gives maximum height of supported chimney.

**NOTE:** For the ACBI chimney, a support section (ACBI7SL) must be used every 30 feet (9m) or an universal support every 20 feet (6m) instead of the universal roof support (ST).

For roof support installation, refer to the instructions provided with the support.

### Universal Offset Support

This support is used to support the chimney above an offset. When the chimney offset is used to traverse a wall this support may be used on the wall to support the chimney. The maximum heights are given in **Table 6**. For offset support installation, refer to the instructions provided with the support.

CHIMNEY	MAXIMUM HEIGHT OF SUPPORTED CHIMNEY	
	Offset Support	Roof Support
Secure Temp S2100+ Nova Temp HT6000+ Secure Temp GX	16 feet (5.49 m).	18 feet (6.1 m).
ACBI	40 feet (12.19 m).	50 feet (15.20 m).

**Table 6**

## CHIMNEY CHASE AND MULTIPLE TERMINATIONS

For the purpose of this manual, a chimney chase is considered a part of the chimney system rather than part of a building. The termination must be placed a minimum of 18" (460 mm) above the chase.

For installations where more than one chimney is located in the same chase or within the same area, we suggest that their terminations be separated by at least 16" (410 mm) horizontally, and 18" (460 mm) vertically. This separation is to prevent smoke migrating from one chimney to another (see **Figure 31**).

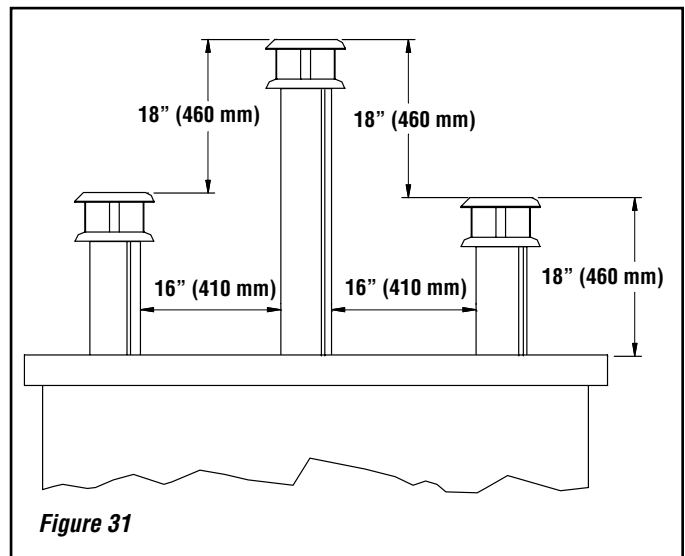

## INSTALLATION INSTRUCTIONS FOR MASONRY APPLICATION

**WARNING:** Before starting the installation, the masonry chimney must be inspected by a qualified chimney sweep.

The following requirements must be respected:

1. The chimney must be absolutely clear of any soot residue or creosote. Check for cracks, loose or missing bricks that could inhibit correct installation of the liner.
2. The clearance to combustible must be a minimum of 1" between the outside of the masonry and any wood framing or loose insulation.
3. The chimney must be built in accordance with the current building code.
4. No other appliance can be connected to the same chimney.
5. The clearances to combustible for the BISTMA30 connectors are 2" on the side and bottom and 16" at the top.
6. The connector parts are not necessary if the connection between the insulated length and the stainless steel liner is done within the masonry chimney.

### Installation:

The chimney must be relined with a stainless steel liner model TUBINOX or Projet SS of the same diameter as the outlet of the fireplace.

For connection at 30° angle, a special connector (BISTMA30) must be used to connect the liner to the insulated chimney.

**\* IMPORTANT NOTE - The use of a 45° connector (BISTMA) is approved for use in Canada ONLY. Installations in the USA must use the 30° connector (BISTMA30).**

### Follow these steps:

- 1- Position the fireplace in its location. Temporarily install the S2100+ elbow on the top of the fireplace and, using a level, mark with an oval the location where the flue liner will enter the masonry chimney.
- 2- In the middle of the oval, drill a hole in the masonry chimney at 30°.
- 3- Increase the size of the hole until a 30° TUBINOX liner elbow can be easily slipped through.
- 4- Slide the liner down from the top of the masonry chimney until you reach the hole level.
- 5- Slip through the hole a 30° liner elbow and connect it to the liner.
- 6- Add a small liner section to the liner elbow which will allow the liner to extend at least 12" (measured at the top of the liner) from the masonry chimney.
- 7- Seal the opening around the liner with high temperature refractory cement.
- 8- The next steps must be done in the following order:

### See typical installation illustrated below.

- A. Select the S2100+ length that will fit between the elbow and the liner so that it will slide at least 2" over the liner section (You may need to cut the liner for a better fit).
- B. Take that section and the BISTMA30 cover and slide it over the liner. Make sure you have enough opening to be able to install the S2100+ elbow without difficulty.
- C. Install the 30° elbow on the fireplace.
- D. Slide the length section back down on the elbow and twist lock the two together.
- E. Pull the cover down over the length and install the insulation pad over the liner; be careful to cover the liner completely.
- F. Slide back the cover over the insulation and fix it in place using the 3 metal screws supplied.

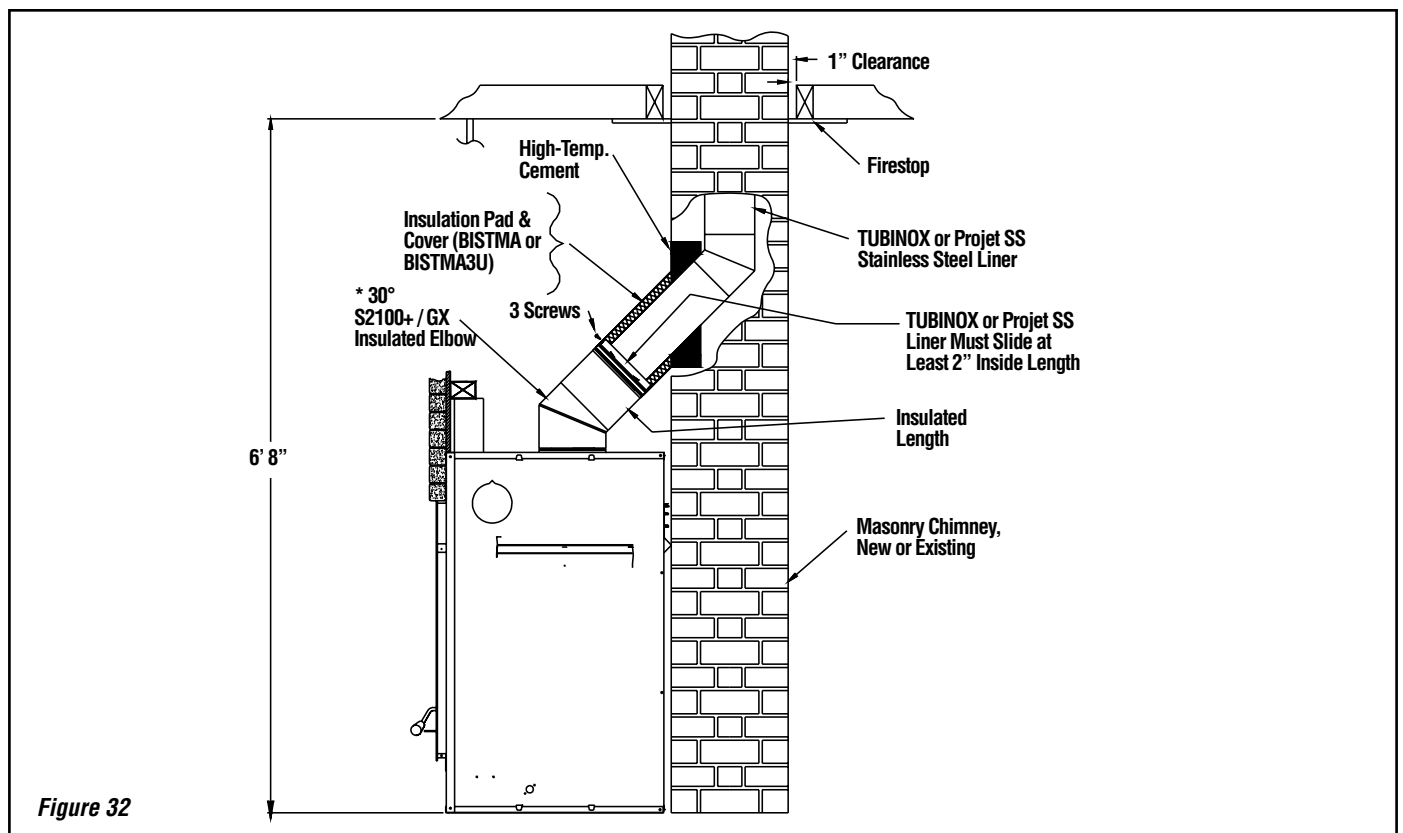

Figure 32

NOTE: DIAGRAMS & ILLUSTRATIONS ARE NOT TO SCALE.

## OPTIONAL INSTALLATION ACCESSORIES

Installation Accessories	
Description	Cat./Part No.
<b>Facades (Required - Order Separately)</b>	
Montecito Estate™ Facade Black, MEFBK	H4850
Montecito Estate Facade Brushed Nickel, MEFBN	H4851
Montecito Estate Facade Hammered Steel, MEFMC	H4852
<b>Doors - (Required - Order Separately)</b>	
Montecito Estate Doors Black, MECBK	H4853
Montecito Estate Doors Brushed Nickel, MECBN	H4854
Montecito Estate Doors Hammered Steel, MECMC	H4855
<b>Outside Air Kit (included with fireplace)</b>	
Outside Air Coupler To Connect Outside Air (UZI) To Fireplace, UZIAD	UZIAD
Outside Air Ducting - includes 4" insulated flex x 10' long, UZI	UZI
<b>Gravity Kit</b>	
<b>Gravity kit:</b> Complete double duct system includes: 2 elbows 90°, 2 telescopic lengths, 2 grill supports & 2 black grills, 2 fireplace adaptors.	7B30ZK-1
<b>Gravity Kit Accessories</b>	
Black Grill With Support (set of 2) , 7B30Z0	7B30Z0
Brass Grill (for 7B30ZK-1) (set of 2), 7B30ZGB	7B30ZGB
Elbow 90°, 8" dia. I.D., 7B26ZE90	7B26ZE90
Elbow 45°, 8" dia. I.D., 7B26ZE45	7B26ZE45
Telescopic length, 8" dia. I.D. (15" to 26"), 7B26ZLA	7B26ZLA
Adjustable length, 8" dia. I.D. (2" - 5"), 7B26ZL2A	7B26ZL2A
Length five (5) feet, 8KL5	8KL5
Length four (4) feet, 8KL4	8KL4
Length three (3) feet, 8KL3	8KL3
Length two (2) feet, 8KL2	8KL2
Length one (1) feet, 8KL1	8KL1
<b>Fireplace Kits</b>	
Rigid firescreen, BTZN	BTZN
Masonry Chimney Adaptor, 30°, BISTMA30 (for use with TUBINOX liner)	BISTMA30

**Fireplace Model MONTEST - Approved Venting Components manufactured by Security Chimneys International only.**

- **7" diameter chimney** - ACBI (air cooled), Secure Temp™ GX (U.S. only) and Secure Temp S-2100+ (or Nova Temp HT6000+).
- **7" diameter chimney for relining masonry chimneys** - TUBINOX chimney (or PROJET SS), 7" diameter with adaptor for installation in a masonry chimney.

## CHIMNEY - PARTS AND COMPONENTS LISTS

<b>Secure Temp GX - 2" Insulated Galvanized Chimney System (Recommended Insulated System)</b> <i>Galvanized (7" ID &amp; 11" OD) U.S.A. ONLY</i>	
Description	Cat./Part No.
<b>Lengths &amp; Misc. Chimney Components</b>	
Length 8", 7GXL8	7GXL8
Length 12", 7GXL12	7GXL12
Length 18", 7GXL18	7GXL18
Length 24", 7GXL24	7GXL24
Length 24" (stainless steel exterior flue), 7XL24	7XL24
Length 36", 7GXL36	7GXL36
Length 36" (stainless steel exterior flue), 7XL36	7XL36
Length 48", 7GXL48	7GXL48
Length 48" (stainless steel exterior flue), 7XL48	7XL48
15° Elbow, 7GXE15	7GXE15
30° Elbow, 7GXE30	7GXE30
Rain Termination Cap, 7CC (stainless steel)	7CC
Wall Band, XBM	XBM
<b>Supports</b>	
Offset Support, XSO	XSO
Roof / Floor support, XST	XST
Roof Brace, XBS2	XBS2
<b>Roof Flashings</b>	
Roof Flashing, Flat (includes spacer & collar), 7XF	7XF
Roof Flashing, Adjustable (5° to 30°) (includes spacer & collar), 7XFA	7XFA
Roof Flashing, Adjustable (30° to 45°) (includes spacer & collar), 7XFB	7XFB
Storm Collar (spacer included), 7XFC	7XFC
<b>Firestops &amp; Braces</b>	
Firestop, 7XBF	7XBF
Radiation shield, 7XRS	7XRS
Insulated attic radiation shield, 7XRSA	7XRSA
30° Insulated wall radiation shield, 7XRSMI30	7XRSMI30
Wall Band, XBM	XBM

**Notes:**

- ① Nova Temp™ HT6000+ is equivalent to S-2100+
- ② Chimney Adaptor (S-2100+ / HT6000+) for CANADA ONLY - If you want to install a S-2100+ / HT6000+ chimney, an adaptor is available (6UCA).
- ③ ACBI Chimney is NOT recommended at elevations above 4,000' - or in cold climates (climates where temperatures will fall below 32° F / 0° C). With the ACBI chimney, you must use a starter section before installing the first chimney length (ACBI7SB or ACBI7SB30).

## CHIMNEY - PARTS AND COMPONENTS LISTS

<b>ACBI Chimney*</b> (7" I.D., 13" O.D. AC - Air Cooled)	
<i>* AC Chimney is NOT recommended at elevations above 4,000 feet or in cold climates (climates where temperatures will fall below 32° F / 0° C).</i>	
Description	Cat./Part No.
<b>One of the following adaptors is required if installing an AC chimney system</b>	
Starter Section w/ air intake, 7" Dia., ACBI7SB	H3258
Offset Starter Section 30°, 7" Dia., ACBI7SB30	H3259
<b>The following outside air kit is required if installing an AC chimney system</b>	
Outside Air Kit (Chimney) (4" ID Flex X 10' Long, Insulation, Outside Register And Coupling), ACZI	H1967
<b>Lengths &amp; Misc. Chimney Components</b>	
12" Length, 7" Dia., ACBI7L12	H3252
18" Length, 7" Dia., ACBI7L18	H3253
36" Length, 7" Dia., ACBI7L36	H3254
48" Length, 7" Dia., ACBI7L48	H3255
15° Elbow, 7" Dia., ACBI7E15	H3256
30° Elbow, 7" Dia., ACBI7E30	H3257
Rain Termination Cap (regular), 7" Dia., ACBI7CPR	H3260
Spark Arrester Screen (universal spark arrester band), PE	PE
Wall Band, XBM	XBM
<b>Supports</b>	
Support section (10" long), ACBI7SL	H3263
Universal support, AC10SU	H3265
<b>Roof Flashings</b>	
Flat roof flashing (includes spacer & collar), ACBI7FR	H3275
Roof Flashing, Adjustable, 5° - 30° (includes spacer & collar), ACBI7FAR	H3276
Roof Flashing, Adjustable, 30° - 45° (includes spacer & collar), ACBI7FBR	H3277
<b>Misc.</b>	
Firestop, ACBI7BF	H3268
Radiation Shield, ACBI7RS	H3269
Attic Radiation Shield, ACBI7RSA	H3270
Telescopic Attic Radiation Shield, ACBI7RST	H3271
Insulated Wall Radiation Shield 30°, AC10RSMI30	H3272
Storm Collar, AC10FC	H3278

<b>TUBINOX LL Chimney Lining System</b> Rigid Stainless Steel Liner For Relining A Masonry Chimney, 7" Diameter <i>Listed to ULC-S635M, UL-1777 &amp; ULC-S640M at 2100° F</i>	
Description	Cat./Part No.
6" Length, 7" Dia., 7LL6	7LL6
12" Length, 7" Dia., 7LL12	7LL12
24" Length, 7" Dia., 7LL24	7LL24
36" Length, 7" Dia., 7LL36	7LL36
48" Length, 7" Dia., 7LL48	7LL48
Adjustable Length (7" to 11"), 7" Dia., 7L7A	7L7A
Split Base Tee, 7" Dia., 7LT	7LT
Tee Cap, 7" Dia., 7TCS	7TCS
Twist Lock Tee Cap, 7" Dia., 7LTC	7LTC
Elbow 30°, 7" Dia., 7LE30	7LE30
Elbow 45°, 7" Dia., 7LE45	7LE45
Elbow 90°, 7" Dia., 7LE90	7LE90
Rain Termination Cap (regular), 7" Dia., 7LCS	7LCS
Rain Termination Cap (deluxe), 7" Dia., 7LCC	7LCC
<b>Supports</b>	
Top Support, Part# 7LST	7LST
Support Assembly, 7LSA	7LSA
Interior Support, Part# 7LSB	7LSB
Adaptor Flexible Pipe (male), 7LAAM	7LAAM
Adaptor Flexible Pipe (female), 7LAAF	7LAAF
Stainless Steel Flex - five (5) feet Long, 7LLFLEX	7LLFLEX
Adj. Insulated Wall Radiation Shield 6" to 12", 7LRSMI	7LRSMI
<b>Adaptors to Masonry Chimney</b>	
Masonry Chimney Adaptor, 30°, BISTMA30 (for use with TUBINOX liner)	BISTMA30

## REPLACEMENT PARTS LIST

Montecito Estate™ - Replacement Parts	
Description	Cat./Part No.
Blower	UZY5
Blower Motor Speed Control	VRUW
Snap Disc, Blower	VTU
Baffle refractory (2 pieces) (top of firebox)	PR-ISO2205
Top Hearth Insulation	PR-ISO2521
Front Refractory Bricks	PR-SR2421
Back Refractory Brick	PR-SR2415
Right Side Refractory Bricks - Back	PR-SR2417
Right Side Refractory Bricks - Front	PR-SR2419
Left Side Refractory Bricks - Back	PR-SR2416
Left Side Refractory Bricks - Front	PR-SR2418
Bottom Refractory Brick	PR-SR2422
Wooden Door Handle	PR-SR1787
Bottom Door Lock	PR-SR2543
Top Door Lock	PR-SR2405
Hinge Assembly, Fireplace & Door	PR-SR1800T
Decorative Screw Caps, Black (2)	PR-SACBTFBK2
Decorative Screw Caps, Brushed Nickel (2)	PR-SACBTFBN2
Timer	PR-SR2425
Ceramic Glass Left	PR-SR2356G
Ceramic Glass Right	PR-SR2356D
Secondary Air Tube (4)	PR-SR2379
Log Retainers (2)	B2CH
Around the Glass Gasket (61-3/4")	PR-SR1685C
On the Door Frame Gasket (48-3/8")	PR-SR1823I
Between the Doors Gasket (17-5/8")	PR-SR1823J
Touch-up Paint, Black	90L73
Outside Air Coupler For AC Chimney 4" ID, UACZI	H3274
Outside Air Coupler To Connect Outside Air (UZI) To Fireplace, UZIAD	UZIAD

## SPECIFICATIONS

Cat. No.	Model
H4842	MONTEST

Product Reference Information	
Weight	450 lbs
Height	49-3/8"
Width	46-1/4"
Depth	27"
Firebox W x H x D measured in front	31" x 14-1/2" x 14"
Chimney weight - <b>Secure Temp GX (7" dia)</b>	9.5 lb/ft.
Chimney weight - ACBI	3.75 lb/ft.

## CLEARANCE TO COMBUSTIBLES

The following clearances meet the minimum requirements for a safe installation:

- **Side wall** (fireplace front): 24" (457 mm) measured from the fireplace side.
- **Ceiling:** 6' 8" (2,032 mm) measured from the base of the fireplace
- **Fireplace enclosure:**
  - Bottom: 0"
  - Side: 0"
  - Back: 0"
- **Top:** Do not fill the space above the fireplace with any material (Except the wood framing. See **Figure 10**)
- **Chimney:** 2" (50 mm), except for through ceiling application, ACBI chimney, 1" (25 mm) clearance.
- **Mantel:** 56" (1422 mm) measured from the base of the fireplace.

## NOTES

# Lennox Hearth Products Wood-Burning Fireplaces, Stoves and Inserts 20 Year Limited Warranty

## THE WARRANTY

Lennox Hearth Products ("LHP") warrants the components of this wood burning factory-built fireplace system, stove or insert manufactured by LHP (LHP System) to be free from defects in materials and workmanship at the time of manufacture.

## REMEDY AND EXCLUSIONS

The coverage of this Warranty is limited to all components of the fireplace system, stove or insert manufactured by LHP, with the exception of optional LHP tempered glass doors. A separate limited warranty is available from LHP for optional glass doors manufactured by LHP. Ceramic glass doors manufactured by LHP are warranted against thermal breakage only. LHP warrants the components of this factory-built system manufactured by LHP (LHP System) to be free from defects in materials and workmanship at the time of manufacture.

- (1) During the first five years of this Warranty, LHP will, at its option and except for the components listed in subparagraphs (a) through (f), below, provide replacement or repair components of the LHP System manufactured by LHP, at no charge, and will also pay for reasonable labor costs incurred in replacing or repairing such components. If repair or replacement is not commercially practicable, LHP will, at its option, refund the purchase price of the LHP Fireplace, Stove or Insert and LHP Chimney Components and Accessories. With respect to the components listed below, the remedies of this paragraph (1) are available only for the period of time indicated. Thereafter, however, until the expiration of 20 years from date of installation, LHP will, subject to the conditions of paragraph (3) below, provide replacements or repairs for those components at 50% off the then prevailing factory list prices for those components.
  - a. Cast iron, iron, or steel fuel grates are considered consumable accessories and therefore are not warranted, with the exception of defects in material or workmanship.
  - b. Fireplace screens, interior refractories, and side shields (metal or refractory) - two years from date of installation.
  - c. Electrical components, such as fan motors and blowers - one year from date of installation (light bulbs are excluded).
  - d. Certain model fireplaces are supplied with standard glass doors which are warranted 90 days from the date of installation for defects in material and workmanship. Replacement glass for fireplaces utilizing tempered glass will be supplied at no-charge during the terms of the 90 day limited warranty with the following exceptions:
    - Accidental glass breakage or damage to the glass door frame finishes incurred in transit, handling or operation either before, during or after installation.
  - e. Certain fireplaces, stoves and inserts are supplied with ceramic glass, which is warranted against thermal breakage only for 2 years from date of installation. LHP will assume no responsibility for glass replacement labor costs.
  - f. Certain fireplaces, stoves and inserts are supplied with catalysts, which are warranted for a period of six years. Warranty coverage for years three - six will be pro-rated from time of installation.
  - g. Air tubes, baffles and brick retainers - one year from date of installation.
  - h. By-pass damper assembly (catalytic models only) - five years from date of installation.
- (2) During the sixth through tenth year of the Warranty, LHP will, at its option, provide replacement or repair components at no-charge, except as is provided for the components listed in subparagraph (a) through (e) above. This coverage provides for parts only and does not include any labor.
- (3) During the eleventh through the twentieth year of the Warranty, LHP will, at its option, provide replacement or repair components at 50% off the then prevailing factory list prices for those components. This coverage only provides for the purchase of replacement or repair components at discount and does not include any labor.

This Warranty covers only parts, and in some instances labor (as provided in subparagraph (1) above). In no case shall LHP be responsible for materials, parts or construction which were not manufactured or supplied by LHP or for the labor necessary to install, repair, or remove such materials, parts or construction. All replacement or repair components will be shipped F.O.B. the nearest LHP factory.

## QUALIFICATIONS TO THE WARRANTY

The complete fireplace Warranty outlined above is further subject to the following qualifications:

- (1) The factory-built fireplace system, stove or insert manufactured by LHP (LHP System) must be installed in accordance with LHP installation instructions and local building codes. The Warranty on this LHP system manufactured by LHP covers only the component parts manufactured by LHP. The use of components manufactured by others with this LHP System could create serious safety hazards, may result in the denial of certification by recognized national safety listing agencies, and could be in violation of local building codes. This Warranty does not cover any damages occurring from the use of any components not manufactured or supplied by LHP. Any modifications to the system or the retro-fitting of any appliance to the system which alters the function or performance of the appliance will void this Warranty.
- (2) The factory-built fireplace system, stove or insert manufactured by LHP (LHP System) is subjected to normal use with fuels stated in the Home Owners Manual. Factory-built fireplace system includes burning such natural fireplace fuels as wood and natural or propane gas. Fuel products with abnormal burning characteristics, including but not limited to fuel such as driftwood, coal or plywood and wood products using a binder, may burn at excessive temperatures and may cause damage to the factory-built fireplace or may cause it to function improperly; stoves and inserts are approved for burning dry seasoned wood only.
- (3) Coverage of this Warranty is conditional upon use of an adequate fireplace grate on factory-built fireplaces only, when applicable. Coverage of this warranty for stoves and inserts is that these appliances are operated without the use of grates, irons or any other method to elevate the fire.
- (4) LHP is not responsible for inadequate fireplace, stove or insert system draft caused by air conditioning, heating, mechanical systems, or general construction conditions which may generate negative air pressure in the room in which the appliance is installed. Additionally LHP assumes no responsibility for smoking conditions caused by inadequate chimney heights from adjoining trees or building, adverse wind conditions or unusual environmental factors and conditions.

## LIMITATION ON LIABILITY

It is expressly agreed and understood that LHP's sole obligation and purchaser's exclusive remedy under this Warranty, under any other warranty, expressed or implied, otherwise, shall be limited to replacement, repair, or refund, as specified above.

In no event shall LHP be responsible for any incidental or consequential damages caused by defects in its products, whether such damage occurs or is discovered before or after replacement or repair, and whether or not such damage is caused by LHP's negligence. Some states do not allow the exclusion or limitation of incidental or consequential damages, so the above limitation or exclusion may not apply to you. The duration of any implied warranty with respect to this LHP fireplace is limited to the duration of the foregoing warranty. Some states do not allow limitations on how long an implied warranty lasts, so the above may not apply to you.

## INVESTIGATION OF CLAIMS AGAINST WARRANTY

LHP reserves the right to investigate any and all claims against this Warranty and to decide upon method of settlement.

## LHP IS NOT RESPONSIBLE FOR WORK DONE WITHOUT WRITTEN CONSENT

LHP shall in no event be responsible for any warranty work done without first obtaining LHP's written consent.

## DEALERS HAVE NO AUTHORITY TO ALTER THIS WARRANTY

LHP's employees and dealers have no authority to make any warranties nor to authorize any remedies in addition to or inconsistent with those stated above.

## HOW TO REGISTER A CLAIM AGAINST WARRANTY

In order for any claim under this Warranty to be valid, LHP must be notified of the claimed defect in writing to Lennox Hearth Products, attention Customer Service Department, 1110 West Taft Avenue, Orange, CA, 92865, as soon as reasonably possible after the defect is discovered. Claims against this Warranty in writing should include the date of installation, and a description of the defect.

## OTHER RIGHTS

This Warranty gives you specific legal rights, and you may have other rights which vary from state to state.

The manufacturer reserves the right to make changes at any time, without notice, in design, materials, specifications, prices and also to discontinue colors, styles and products. Consult your local distributor for fireplace code information.