



GE Healthcare

Technical Publication

**Direction 5305880-100
Revision 3**

**GE Healthcare
LOGIQ™ 100 PRO Service Manual**

Copyrighted© 1995-2008 by General Electric Co.
All Rights Reserved.



RELEASED UNDER
SECTION 552A

Your Notes:

RELEASED UNDER
SECTION 104

IMPORTANT PRECAUTIONS

LANGUAGE

WARNING

- THIS SERVICE MANUAL IS AVAILABLE IN ENGLISH ONLY.
- IF A CUSTOMER'S SERVICE PROVIDER REQUIRES A LANGUAGE OTHER THAN ENGLISH, IT IS THE CUSTOMER'S RESPONSIBILITY TO PROVIDE TRANSLATION SERVICES.
- DO NOT ATTEMPT TO SERVICE THE EQUIPMENT UNLESS THIS SERVICE MANUAL HAS BEEN CONSULTED AND IS UNDERSTOOD.
- FAILURE TO HEED THIS WARNING MAY RESULT IN INJURY TO THE SERVICE PROVIDER, OPERATOR OR PATIENT FROM ELECTRIC SHOCK, MECHANICAL OR OTHER HAZARDS.

AVERTISSEMENT

- CE MANUEL DE MAINTENANCE N'EST DISPONIBLE QU'EN ANGLAIS.
- SI LE TECHNICIEN DU CLIENT A BESOIN DE CE MANUEL DANS UNE AUTRE LANGUE QUE L'ANGLAIS, C'EST AU CLIENT QU'IL INCOMBE DE LE FAIRE TRADUIRE.
- NE PAS TENTER D'INTERVENTION SUR LES ÉQUIPEMENTS TANT QUE LE MANUEL SERVICE N'A PAS ÉTÉ CONSULTÉ ET COMPRIS.
- LE NON-RESPECT DE CET AVERTISSEMENT PEUT ENTRAÎNER CHEZ LE TECHNICIEN, L'OPÉRATEUR OU LE PATIENT DES BLESSURES DUES À DES DANGERS ÉLECTRIQUES, MÉCANIQUES OU AUTRES.

WARNUNG

- DIESES KUNDENDIENST-HANDBUCH EXISTIERT NUR IN ENGLISCHER SPRACHE.
- FALLS EIN FREMDER KUNDENDIENST EINE ANDERE SPRACHE BENÖTIGT, IST ES AUFGABE DES KUNDEN FÜR EINE ENTSPRECHENDE ÜBERSETZUNG ZU SORGEN.
- VERSUCHEN SIE NICHT, DAS GERÄT ZU REPARIEREN, BEVOR DIESES KUNDENDIENST-HANDBUCH NICHT ZU RATE GEZOGEN UND VERSTANDEN WURDE.
- WIRD DIESE WARNUNG NICHT BEACHTET, SO KANN ES ZU VERLETZUNGEN DES KUNDENDIENSTTECHNIKERS, DES BEDIENERS ODER DES PATIENTEN DURCH ELEKTRISCHE SCHLÄGE, MECHANISCHE ODER SONSTIGE GEFAHREN KOMMEN.

AVISO

- ESTE MANUAL DE SERVICIO SÓLO EXISTE EN INGLÉS.
- SI ALGÚN PROVEEDOR DE SERVICIOS AJENO A GEMS SOLICITA UN IDIOMA QUE NO SEA EL INGLÉS, ES RESPONSABILIDAD DEL CLIENTE OFRECER UN SERVICIO DE TRADUCCIÓN.
- NO SE DEBERÁ DAR SERVICIO TÉCNICO AL EQUIPO, SIN HABER CONSULTADO Y COMPRENDIDO ESTE MANUAL DE SERVICIO.
- LA NO OBSERVANCIA DEL PRESENTE AVISO PUEDE DAR LUGAR A QUE EL PROVEEDOR DE SERVICIOS, EL OPERADOR O EL PACIENTE SUFRAN LESIONES PROVOCADAS POR CAUSAS ELÉCTRICAS, MECÁNICAS O DE OTRA NATURALEZA.

ATENÇÃO

- ESTE MANUAL DE ASSISTÊNCIA TÉCNICA SÓ SE ENCONTRA DISPONÍVEL EM INGLÊS.
- SE QUALQUER OUTRO SERVIÇO DE ASSISTÊNCIA TÉCNICA, QUE NÃO A GEMS, SOLICITAR ESTES MANUAIS NOUTRO IDIOMA, É DA RESPONSABILIDADE DO CLIENTE FORNECER OS SERVIÇOS DE TRADUÇÃO.
- NÃO TENHA TENTADO REPARAR O EQUIPAMENTO SEM TER CONSULTADO E COMPRENDIDO ESTE MANUAL DE ASSISTÊNCIA TÉCNICA.
- O NÃO CUMPRIMENTO DESTA AVISO PODE POR EM PERIGO A SEGURANÇA DO TÉCNICO, OPERADOR OU PACIENTE DEVIDO A CHOQUES ELÉTRICOS, MECÂNICOS OU OUTROS.

AVVERTENZA

- IL PRESENTE MANUALE DI MANUTENZIONE È DISPONIBILE SOLTANTO IN INGLESE.
- SE UN ADDETTO ALLA MANUTENZIONE ESTERNO ALLA GEMS RICHIEDE IL MANUALE IN UNA LINGUA DIVERSA, IL CLIENTE È TENUTO A PROVVEDERE DIRETTAMENTE ALLA TRADUZIONE.
- SI PROCEDA ALLA MANUTENZIONE DELL'APPARECCHIATURA SOLO DOPO AVER CONSULTATO IL PRESENTE MANUALE ED AVERNE COMPRESO IL CONTENUTO.
- NON TENERE CONTO DELLA PRESENTE AVVERTENZA POTREBBE FAR COMPIERE OPERAZIONI DA CUI DERIVINO LESIONI ALL'ADDETTO ALLA MANUTENZIONE, ALL'UTILIZZATORE ED AL PAZIENTE PER FOLGORAZIONE ELETTRICA, PER URTI MECCANICI OD ALTRI RISCHI.

警告

このサービスマニュアルには英語版しかありません。
GEMS以外でサービスを担当される業者が英語以外の言語を要求される場合、翻訳作業はその業者の責任で行うものとさせていただきます。
このサービスマニュアルを熟読し理解せずに、装置のサービスを行わないで下さい。
この警告に従わない場合、サービスを担当される方、操作員あるいは患者さんが、感電や機械的又はその他の危険により負傷する可能性があります。

注意:

本维修手册仅存有英文本。
非 GEMS 公司的维修员要求非英文本的维修手册时，
客户需自行负责翻译。
未详细阅读和完全了解本手册之前，不得进行维修。
忽略本注意事项会对维修员，操作员或病人造成触电，机械伤害或其他伤害。

DAMAGE IN TRANSPORTATION

All packages should be closely examined at time of delivery. If damage is apparent write "Damage In Shipment" on ALL copies of the freight or express bill BEFORE delivery is accepted or "signed for" by a GE representative or hospital receiving agent. Whether noted or concealed, damage MUST be reported to the carrier immediately upon discovery, or in any event, within 14 days after receipt, and the contents and containers held for inspection by the carrier. A transportation company will not pay a claim for damage if an inspection is not requested within this 14 day period.

CERTIFIED ELECTRICAL CONTRACTOR STATEMENT - FOR USA ONLY

All electrical installations that are preliminary to positioning of the equipment at the site prepared for the equipment shall be performed by licensed electrical contractors. Other connections between peices of electrical equipment, calibrations and testing shall be performed by qualified GE Medical Systems personnel. In performing all electrical work on these products, GE will use its own specially trained filed engineers. All of GE's electrical work on these products will comply with the requirements of the applicable electrical codes.

The purchaser of GE equipment shall only utilize qualified personnel (i.e., GE's field engineer's, personnel of third party service companies with equivalent training, or licensed electricians) to perform electrical servicing on the equipment.

OMISSIONS & ERRORS

If there are any omissions, errors or suggestions for improving this documentation, please contact the GE Medical Systems Global Documentation Group with specific information listing the system type, manual title, part number, revision number, page number and suggestion details. Mail the information to : Service Documentation, 9900 Innovation Drive (RP-2123), Wauwatosa, WI 53226. , USA.

GE Medical Systems employees should use the iTrack System to report all documentation errors or omisions.

LEGAL NOTES

The contents of this publication may not be copied or duplicated in any form, in whole or in part, without prior written permission of GE Medical Systems.
GE Medical Systems may revise this publication from time to time without written notice.

TRADEMARKS

All products and their name brands are trademarks of their respective holders.

COPYRIGHTS

All Material Copyright© 1997-2007 by General Electric Inc. All Rights Reserved.

RELEASED UNDER
SECTION 104

Revision History

Revision	Date	Reason for change
1	JAN 26 2008	Preliminary Release.
2	APRIL 24 2008	Changes incorporated for correcting the SPR's raised against DOC0421436.
3	August 4 2008	Changes incorporated on contact details and added additional information based on service teams requirements.

RELEASED UNDER
SECTION 104

RELEASED UNDER
SECTION 104

Table Of Contents

Chapter Table Of Contents

Chapter 1 Introduction

Section 1-1 Overview	1-1
1-1-1 Overview	1-1
1-1-2 Purpose of Chapter 1	1-1
1-1-3 Purpose of Service Manual	1-1
1-1-4 Typical Users of the Basic Service Manual	1-2
1-1-5 LOGIQ™ 100 PRO Models Covered by this Manual	1-2
1-1-6 Purpose of Operator Manual(s)	1-2
Section 1-2 Safety	1-3
1-2-1 Warnings	1-3
Section 1-3 Important Conventions	1-4
1-3-1 Conventions Used in Book	1-4
1-3-2 Standard Hazard Icons	1-5
1-3-3 Product Icons	1-6
Section 1-4 Safety Considerations	1-10
1-4-1 Introduction	1-10
1-4-2 Human Safety	1-10
1-4-3 Mechanical Safety	1-11
1-4-4 Electrical Safety	1-11
1-4-5 Labels Locations	1-12
1-4-6 Dangerous Procedure Warnings	1-18
1-4-7 Lockout/Tagout Requirements (For USA Only)	1-18
1-4-8 Classification	1-18
Section 1-5 EMC, EMI, and ESD	1-19
1-5-1 Electromagnetic Compatibility (EMC)	1-19
1-5-2 CE Compliance	1-19
1-5-3 EMC Performance	1-19
1-5-4 Notice Upon Installation of Product	1-19
1-5-5 General Notice	1-20
1-5-6 Countermeasures against EMC related Issues	1-20
1-5-7 Notice on Service	1-20
1-5-8 Electrostatic Discharge (ESD) Prevention	1-21
Section 1-6 Customer Assistance	1-21
1-6-1 System Manufacturer	1-21
1-6-2 Contact Information	1-22

Chapter 2 Pre Installation

Section 2-1 Overview	2-1
2-1-1 Purpose of Chapter 2	2-1
Section 2-2 General Console Requirements	2-1
2-2-1 Console Environmental Requirements	2-1

Lighting 2	
2-2-2 Electrical Requirements	2-2
2-2-2-1 LOGIQ™ 100 PRO Power Requirements	2-2
2-2-2-2 Site Circuit Breaker	2-2
2-2-2-3 Site Power Outlets.....	2-2
2-2-2-4 Unit Power Plug.....	2-2
2-2-2-5 Power Stability Requirements	2-2
2-2-3 EMI Limitations 2-3	
2-2-4 Probes Environmental Requirements	2-4
2-2-5 Time and Manpower Requirements	2-5
2-2-6 Checklist for Installation	2-5
2-2-6-1 Checklist for Installation	2-5

Chapter 3 Installation

Section 3-1 Overview.....	3-1
3-1-1 Purpose of Chapter 3	3-1
3-1-2 Average Installation Time.....	3-1
3-1-3 Safety Reminders 3-2	
Section 3-2 Receiving and Unpacking the Equipment.....	3-3
Section 3-3 Preparing for Installation	3-5
3-3-1 Physical Inspection	3-5
3-3-1-1 Systems Voltage Settings	3-5
3-3-1-2 Video Formats	3-5
3-3-2 EMI Protection.....	3-5
Section 3-4 Assembling LOGIQ™ 100 PRO	3-5
3-4-1 Installation of the System.....	3-5
Section 3-5 Completing the Installation	3-6
3-5-1 Transducer Connection	3-6
3-5-2 Installation of Optional Accessories	3-7
3-5-3 Installation of Two Probe Adapter & LOGIQ a200 Probe Adapter (Optional) 3-9	
3-5-4 Installation of LOGIQ™ 100 PRO with Global or Modular Trolley 3-11	
3-5-5 Adjustment of Monitor Brightness & Contrast 3-17	
3-5-6 Adjustment of System Clock/Date, Hospital Name & OB Version	3-17
Section 3-6 System Configuration	3-17
3-6-1 System Specifications	3-17
3-6-1-1 Physical Dimensions	3-17
Front View 18	
3-6-1-3 Side View (Keyboard Closed)	3-19
3-6-1-4 Side View (Keyboard Open).....	3-19
3-6-1-5 Weight without Peripherals.....	3-20
3-6-2 Electrical Specifications	3-20
3-6-2-1 Power Supply	3-21
3-6-2-2 Facility Power Socket.....	3-21
3-6-2-3 Storage & Operation Requirements	3-21
3-6-3 Optional Peripherals.....	3-21
3-6-4 Peripherals Connections and Installation 3-23	
3-6-5 Video Specification 3-28	

Section 3-7 Paperwork	3-28
3-7-1 User Manual(s)	3-29
3-7-2 Product Locator Card.....	3-29

Chapter 4 Functional Checks

Section 4-1	Overview 4-1
4-1-1 Purpose of Chapter 4.....	4-1
Section 4-2 General Procedures	4-2
4-2-1 Power On/Boot Up.....	4-2
4-2-1-1 System Boot-UP/Shutdown	4-2
4-2-1-2 Lockout/Tagout Requirements (For USA/Europe).....	4-2
4-2-1-3 Power Up	4-2
Front Panel ON/OFF 3	
4-2-1-5 Power Shutdown.....	4-3
Section 4-3 Functional Check Procedures	4-4
4-3-1 Power Up Monitor Display (Convex Probe)	4-5
4-3-2 Basic Controls.....	4-6
Section 4-4 Diagnostics	4-9
4-4-1 Power On Diagnostics	4-9
4-4-2 Service Diagnostics	4-9
Section 4-5 Software Configuration Checks	4-10
Section 4-6 Peripheral Checks	4-10
Section 4-7 Patient contact tools	4-11
4-7-1 Probe/Connectors Check.....	4-11
Section 5-1 Overview	5-1
5-1-1 Purpose of Chapter 5.....	5-1
Section 5-2 General Information	5-2
Section 5-3 Block Diagram	5-3
5-3-1 DAVINCI Block Diagram.....	5-5
5-3-2 LOGIQ™ 100 PRO BLOCK DIAGRAM.....	5-6
5-3-3 PCB Nomenclature	5-7
Section 5-4 Wiring Diagrams	5-8
5-4-0-1 Power Distributor/Power Supply Wiring Diagram	5-8
Cable Assembly Diagrams 10	
Section 5-5 Functional Subsystems	5-12
5-5-1 Front End Board	5-12
5-5-2 Davinci Board	5-13
5-5-3 Peripherals.....	5-14
Section 5-6 Video Specifications	5-14
Section 5-7 Rear Panel Signal List	5-14

Chapter 6 Service Adjustments

Section 6-1 Overview	6-1
6-1-1 Service Adjustments Available in LOGIQ™ 100 PRO	6-1

Chapter 7 Diagnostics/Troubleshooting

Section 7-1 Overview.....	7-1
7-1-1 Purpose of Chapter 7	7-1
Section 7-2 Power On Diagnostics	7-3
7-2-1 DAVINCI Board Tests 7-4	
7-2-2 FEB Test for LOGIQ™ 100 PRO	7-7
7-2-3 Keyboard Tests 7-9	
7-2-4 Monitor Test 7-10	
7-2-5 Key Operation History	7-13
Section 7-3 Error Reporting.....	7-14
7-3-1 Error Reporting.....	7-14
Section 7-4 Troubleshooting	7-15

Chapter 8 Replacement Procedures

Section 8-1 Overview.....	8-1
8-1-1 Purpose of Chapter 8	8-1
Section 8-2 Top Cover.....	8-2
8-2-1 Disassembly/Assembly of Top Cover	8-2
Section 8-3 KEYBOARD	8-4
8-3-1 Detaching the Keyboard.....	8-4
8-3-2 Keyboard Disassembly/Assembly 8-6	
Optical Trackball Assembly 8	
Optical Trackball Assembly 9	
Section 8-4 FRONT PANEL/MONITOR	8-10
8-4-1 Disassembly/Assembly of Front Panel.....	8-10
8-4-2 Disassembly/Assembly of Monitor	8-12
Section 8-5 PCBs	8-14
8-5-1 Disassembly/Assembly of Davinci Board.....	8-14
8-5-2 Disassembly/Assembly of FEB for LOGIQ™ 100 PRO 8-18	
Section 8-6 Fan Assembly	8-20
8-6-1 Disassembly/Assembly of Fan	8-20
Section 8-7 Power Supply/Distributor PCB.....	8-21
8-7-1 Disassembly/Assembly of Power Supply/Distributor PCB	8-21
Section 8-8 Rear Panel	8-22
8-8-1 Disassembly/Assembly of Rear Panel	8-22
Section 8-9 HV Assembly.....	8-24
8-9-1 Disassembly/Assembly of HV Assembly.....	8-24
Section 8-10 Chassis.....	8-25
8-10-1 Disassembly/Assembly of Chassis.	8-25

Chapter 9 Replacement Parts

Section 9-1	Overview 9-1
9-1-1 Purpose of Chapter 9.....	9-1
9-1-2 MATERIAL LIST - Top Cover	9-3
9-1-3 MATERIAL LIST - KEYBOARD	9-4
9-1-4 MATERIAL LIST - KEYBOARD ASSEMBLY	9-5
9-1-5 MATERIAL LIST - FRONT PANEL.....	9-7
9-1-6 MATERIAL LIST - Monitor	9-8
9-1-7 MATERIAL LIST - DAVINCI	9-9

Chapter 10 Quality Assurance

Section 10-1 Overview	10-1
10-1-1 Purpose of Chapter 10.....	10-1
Section 10-2 Why do Periodic Maintenance	10-2
10-2-1 Keeping Records	10-2
10-2-2 Quality Assurance.....	10-2
Section 10-3 Periodic Maintenance Schedule	10-2
10-3-1 How often should PMs be performed?	10-2
Section 10-4 Tools Required	10-4
10-4-1 Standard GE Tool Kit.....	10-4
10-4-2 Special Tools, Supplies and Equipment	10-6
10-4-2-1 Specific Requirements for Periodic Maintenance	10-6
Section 10-5 System Periodic Maintenance	10-7
10-5-1 Preliminary Checks.....	10-7
10-5-2 Functional Checks (See Also Chapter 4).....	10-8
10-5-2-1 System Checks	10-8
Peripheral/Option Checks 9	
10-5-3 Input Power.....	10-9
10-5-3-1 Mains Cable Inspection.....	10-9
10-5-4 Cleaning.....	10-9
10-5-4-1 General Cleaning	10-9
10-5-5 Physical Inspection	10-10
10-5-6 Probe Maintenance.....	10-10
10-5-6-1 Probe Related Checks	10-10
10-5-6-2 Basic Probe Care	10-10
Basic Probe Cleaning 11	
Section 10-6 Electrical Safety Tests	10-11
10-6-1 Safety Test Overview.....	10-11
10-6-2 GEMS Leakage Current Limits	10-13
10-6-3 Outlet Test - Wiring Arrangement - USA & Canada	10-14
10-6-4 Grounding Continuity	10-15
10-6-4-1 Meter Procedure	10-15
10-6-5 Chassis Leakage Current Test	10-16
10-6-5-1 Definition	10-16
10-6-5-2 Generic Procedure	10-16
Dale 600 Meter Procedure 17	
Data Sheet for Chassis Source Leakage Current 18	

10-6-6	Probe Leakage Current Test	10-19
10-6-6-1	Definition.....	10-19
10-6-6-2	Generic Procedure for Leakage current	10-19
10-6-6-3	Meter Procedure Using Dale Meter to measure leakage current	10-19
	Meter Procedure using Probe Adapter to measure Probe isolation(Sink) Current	21
	Section 10-7 When There's Too Much Leakage Current.....	10-23

RELEASED UNDER E.O. 14176
SECTION 107

Chapter 1 Introduction

Section 1-1 Overview

1-1-1 Overview

The LOGIQ™ 100 PRO is a compact portable ultrasound scanner which is designed for OB/GYN, Abdomen, Urology and small part Scans using the convex, linear and micro-convex (Transvaginal) probes. High quality images can be obtained by the proper selection of scan control parameters. The diagnostic clarity is further enhanced by the different measurement and calculation packages available in the system.

1-1-2 Purpose of Chapter 1

This chapter describes important issues related to safely servicing this ultrasound machine. The service provider must read and understand all the information presented here before installing or servicing a unit.

CONTENTS IN CHAPTER 1

Section	Description	Page Number
1-1	Overview	1-1
1-3	Important Conventions	1-4
1-4	Safety Considerations	1-9
1-5	EMC, EMI, and ESD	1-18
1-6	Customer Assistance	1-20

Table 1-1 Contents in Chapter 1

1-1-3 Purpose of Service Manual

This Service Manual provides installation and service information for the LOGIQ™ 100 PRO Ultrasound Scanning System and contains the following chapters:

- 1.) **Chapter 1, Introduction:** Contains a content summary and warnings.
- 2.) **Chapter 2, Pre-Installation:** Contains any pre-installation requirements for the LOGIQ™ 100 PRO.
- 3.) **Chapter 3, Installation:** Contains installation procedure with installation checklist.
- 4.) **Chapter 4, Functional Checks:** Contains functional checks that must be performed as part of the installation, or as required during servicing and periodic maintenance.
- 5.) **Chapter 5, Theory:** Contains block diagrams and functional explanations of the electronics.
- 6.) **Chapter 6, Service Adjustments:** Contains instructions on how to make any available adjustments to the LOGIQ™ 100 PRO.
- 7.) **Chapter 7, Diagnostics/Troubleshooting:** Provides procedures for running and diagnostic or related routines for the LOGIQ™ 100 PRO.
- 8.) **Chapter 8, Replacement Procedures:** Provides disassembly procedures and reassembly procedures for all changeable FRU.

- 9.) **Chapter 9, Replacement Parts:** Contains a complete list of replacement parts for the LOGIQ™ 100 PRO.
- 10.) **Chapter 10, Quality Assurance:** Provides periodic maintenance procedures for the LOGIQ™ 100 PRO.

1-1-4 Typical Users of the Basic Service Manual

- Service Personnel (installation, maintenance, etc.).
- Hospital's Service Personnel
- Architects (Some parts of the Pre Installation Chapter)

1-1-5 LOGIQ™ 100 PRO Models Covered by this Manual

Hcat Number	Description	Comments
H41072LA,H41072LB, H41072LC,H41072LD, H41072LE,H41072LF, H41072LS	LOGIQ™ 100 PRO, 100V - 230V	

Table 1-2 LOGIQ™ 100 PRO Models Covered in this Manual

1-1-6 Purpose of Operator Manual(s)

The Operator Manual(s) should be fully read and understood before operating the LOGIQ™ 100 PRO and also kept near the unit for quick reference.

Section 1-2 Safety

1-2-1 Warnings



WARNING CAREFULLY READ ALL THE WARNINGS BELOW

- 1.) The operator manual should be read and understood before operating the LOGIQ™ 100 PRO and kept nearby for quick reference.
- 2.) Although the ultrasound energy transmitted from the LOGIQ™ 100 PRO transducer is within AIUM/NEMA standards, unnecessary exposure should be avoided. Only trained personnel should operate the LOGIQ™ 100 PRO.
- 3.) To prevent electric shock, the LOGIQ™ 100 PRO should be connected to a properly grounded power receptacle. Do not use a three prong to two prong adapter. This defeats safety grounding/
- 4.) Probes are fragile, Please handle with care.
- 5.) Concerning outside markings, refer to Figure 1-2 through 1-3.
- 6.) For the cleaning, disinfection, and sterilization, refer to Probe section in LOGIQ™ 100 PRO User Manual and Caution Sheet supplied with each probe.



NOTICE This medical equipment is approved, in terms of the prevention of radio wave interference, to be used in hospitals, clinics and other institutions which are environmentally qualified. The use of this equipment in an inappropriate environment may cause some electronic interference to radios and televisions around the equipment. Proper handling of this equipment is required in order to avoid such trouble according to the operator and service manuals. This equipment can be used in residential areas only under the supervision of physicians and qualified technicians.



CAUTION Improper performance possibility. Do not use the following devices near this equipment. Cellular phone, radio transceiver, mobile radio transmitter, radio-controlled toy, etc. Use of these devices near this equipment could cause this equipment to perform outside the published specifications. Keep power to these devices turned off when near this equipment.

Section 1-3 Important Conventions

1-3-1 Conventions Used in Book

Model Designations.

This manual covers the LOGIQ™ 100 PRO scanners.
(See “LOGIQ™ 100 PRO Models Covered by this Manual” on page 1-2.)

Icons.

Pictures, or icons, are used wherever they will reinforce the printed message. The icons, labels and conventions used on the product and in the service information are described in this chapter.

Safety Precaution Messages.

Various levels of safety precaution messages may be found on the equipment and in the service information. The different levels of concern are identified by a flag word that precedes the precautionary message. Known or potential hazards are labeled in one of three ways:

 **DANGER** **DANGER IS USED TO INDICATE THE PRESENCE OF A HAZARD THAT WILL CAUSE SEVERE PERSONAL INJURY OR DEATH IF THE INSTRUCTIONS ARE IGNORED.**

 **WARNING** **WARNING IS USED TO INDICATE THE PRESENCE OF A HAZARD THAT CAN CAUSE SEVERE PERSONAL INJURY OR PROPERTY DAMAGE IF INSTRUCTIONS ARE IGNORED.**

 **CAUTION** **Caution is used to indicate the presence of a hazard that will or can cause minor personal injury and property damage if instructions are ignored.**

 **NOTICE** *Equipment Damage Possible*
Notice is used when a hazard is present that can cause property damage but has absolutely no personal injury risk.

NOTE: *Notes provide important information about an item or a procedure. Information contained in a NOTE can often save you time or effort.*

1-3-2 Standard Hazard Icons

Important information will always be preceded by the exclamation point contained within a triangle, as seen throughout this chapter. In addition to text, several different graphical icons (symbols) may be used to make you aware of specific types of hazards that could cause harm.







ELECTRICAL	MECHANICAL	RADIATION
		
LASER	HEAT	PINCH
 LASER LIGHT		

Table 1-3 Standard Hazard Icons

Other hazard icons make you aware of specific procedures that should be followed.

AVOID STATIC ELECTRICITY	TAG AND LOCK OUT	WEAR EYE PROTECTION
		 EYE PROTECTION

Table 1-4 Standard Icons Indicating a Special Procedure to be Used

1-3-3 Product Icons

The following table describes the purpose and location of safety labels and other important information provided on the equipment.



LABEL/SYMBOL	PURPOSE/MEANING	LOCATION
Identification and Rating Plate	Manufacturer's name and address Date of manufacture Model and serial numbers Electrical ratings	Rear of console near power inlet
Type/Class Label	Used to indicate the degree of safety or protection.	
IP Code (IPX8)	Indicates the degree of protection provided by the enclosure per IEC 529. IPX8 indicates drip proof.	Footswitch
	Equipment Type BF (man in the box symbol) IEC 878-02-03 indicates B Type equipment having a floating applied part.	Probe connectors and PCG connector
	Equipment Type CF (heart in the box symbol) IEC 878-02-05 indicates equipment having a floating applied part having a degree of protection suitable for direct cardiac contact.	ECG connector and surgical probes
Device Listing/Certification Labels	Laboratory logo or labels denoting conformance with industry safety standards such as UL or IEC.	Rear of console
CAUTION - This unit weighs...Special care must be used to avoid..."	This precaution is intended to prevent injury that may result if one person attempt to move the unit considerable distances or on an incline due to the weight of the unit.	On the console where easily seen during transport?
"DANGER - Risk of explosion used in..."	The system is not designed for use with flammable anesthetic gases.	Rear of console

Table 1-5 Product Icons

UNCLASSIFIED//FOR OFFICIAL USE ONLY
 RELEASED UNDER E.O. 13526







LABEL/SYMBOL	PURPOSE/MEANING	LOCATION
	"CAUTION" The equilateral triangle is usually used in combination with other symbols to advise or warn the user.	Various
	ATTENTION - Consult accompanying documents " is intended to alert the user to refer to the operator manual or other instructions when complete information cannot be provided on the label.	Various
	"CAUTION - Dangerous voltage" (the lightning flash with arrowhead in equilateral triangle) is used to indicate electric shock hazards.	Various
	"Mains OFF" Indicates the power off position of the mains power switch.	Rear of system adjacent to mains switch
	"OFF/Standby" Indicates the power off/standby position of the power switch. CAUTION This Power Switch DOES NOT ISOLATE Mains Supply	Adjacent to On-Off/Standby Switch
	"Mains ON" Indicates the power on position of the mains power switch. "ON" Indicates the power on position of the power switch. CAUTION This Power Switch DOES NOT ISOLATE Mains Supply	
	"Protective Earth" Indicates the protective earth (grounding) terminal.	

Table 1-5 Product Icons

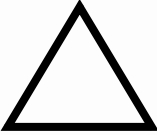



LABEL/SYMBOL	PURPOSE/MEANING	LOCATION
	<p>"Equipotentiality" Indicates the terminal to be used for connecting equipotential conductors when interconnecting (grounding) with other equipment.</p>	<p>Rear of console</p>
	<p>"Non-Ionizing Radiation" indicates that the system applies RF energy.</p>	<p>Rear of console near power inlet</p>
	<p>This symbol indicates that waste electrical and electronic equipment must not be disposed of as unsorted municipal waste and must be collected separately. Please contact an authorised representative for manufacturer for information concerning the decomposition of your requirement.</p>	<p>Rear Panel.</p>
	<p>Indicates the presence of hazardous substance(s) above the maximum concentration value. Maximum concentration values for electronic information products, as set by the People's Republic of China Electronic Industry Standard SJ/T11364-2006, include the hazardous substances of lead, mercury, hexavalent chromium, cadmium, polybrominated biphenyl (PBB), and polybrominated diphenyl ether (PBDE). "10" indicates the number of years during which the hazardous substance(s) will not leak or mutate so that the use of this product will not result in any severe environmental pollution, bodily injury, or damage to any assets.</p>	<p>Rear Panel.</p>

Table 1-5 Product Icons

LABEL/SYMBOL	PURPOSE/MEANING	LOCATION
	<p>No hazardous substance, above the maximum concentration value, are present. Maximum concentration values for electronic information products, as set by the People's Republic of China Electronic Industry Standard SJ/T11364-2006, include the hazardous substances of lead, mercury, hexavalent chromium, cadmium, polybrominated biphenyl (PBB), and polybrominated diphenyl ether (PDBE).</p>	<p>Rear Panel.</p>

Table 1-5 Product Icons

Section 1-4 Safety Considerations

1-4-1 Introduction

The following safety precautions must be observed during all phases of operation, service and repair of this equipment. Failure to comply with these precautions or with specific warnings elsewhere in this manual, violates safety standards of design, manufacture and intended use of the equipment.



WARNING CARE FULLY READ ALL THE WARNINGS LISTED BELOW.

- 1.) Read the LOGIQ™ 100 PRO Operator Manual thoroughly before operating the system and keep at hand for ready reference.
- 2.) Although the ultrasound energy transmitted from the LOGIQ™ 100 PRO transducer is within AIUM/NEMA standards, unnecessary exposure should be avoided. Only trained personnel should operate/service the LOGIQ™ 100 PRO.
- 3.) To avoid electrical shock, use only the supplied power cords and connect them to properly grounded power Sock et. Do not use a three pin to two pin adapter. This defeats the purpose of safety grounding. System should be operated within the voltage limits.
- 4.) Probes are fragile, please handle with care. **A damaged probe may cause an electrically hazardous condition when coupled to the human body.** A damaged probe will not produce a desirable image. A damaged probe has to be discarded. It cannot be repaired or reused. Do not allow the lens to come into contact with a sharp object or to be knocked against an object.
- 5.) Do not place liquids on or above the console. If the liquid spills, it may come in to contact with live parts and can cause an electric shock. This system contains no operator serviceable components. To prevent shock, do not remove any covers or panels. Should problems or malfunctions occur, unplug the power cord. Only qualified Service personnel should service the system. Accidentally coming in contact with the electrical circuits inside the housing could cause serious injury.
- 6.) Do not use Defibrillators when the LOGIQ™ 100 PRO is operated.
- 7.) Concerning outside markings, refer to ILLUSTRATION 1-1 .
- 8.) The LOGIQ™ 100 PRO system should not be placed on a soft surface, as it prevents proper air circulation. The vents for air circulation are on the bottom cover.

Note: This medical equipment is approved, in terms of the prevention of radio wave interference, to be used in hospitals, clinics and other institutions which are environmentally qualified. The use of this equipment in an inappropriate environment may cause some electronic interference to radios and television around the equipment. Proper handling of this equipment is required in order to avoid such trouble according to the operator and service manuals.

1-4-2 Human Safety

Operating personnel must not remove the system covers.

Service should be performed by authorized personnel only.

Only personnel who have participated in a LOGIQ™ 100 PRO Training Seminar are authorized to service the equipment.

1-4-3 Mechanical Safety

 **WARNING** **ULTRASOUND PROBES ARE HIGHLY SENSITIVE MEDICAL INSTRUMENTS THAT CAN EASILY BE DAMAGED BY IMPROPER HANDLING. USE CARE WHEN HANDLING AND PROTECT FROM DAMAGE WHEN NOT IN USE. DO NOT USE A DAMAGED OR DEFECTIVE PROBE. FAILURE TO FOLLOW THESE PRECAUTIONS CAN RESULT IN SERIOUS INJURY AND EQUIPMENT DAMAGE.**

 **WARNING** **NEVER USE A PROBE THAT HAS FALLEN TO THE FLOOR. EVEN IF IT LOOKS OK, IT MAY BE DAMAGED.**

 **CAUTION** Always lock the Control Console in its parking (locked) position before moving the scanner around.

 **CAUTION** The LOGIQ™ 100 PRO weights 10kg or more, depending on installed peripherals, (309 lbs, or more) when ready for use. Care must be used when moving it or replacing its parts. Failure to follow the precautions listed below could result in injury, uncontrolled motion and costly damage.

NOTE: Special care should be taken when transporting the unit in a vehicle:

- *Secure the unit in an upright position.*
- *Lock the wheels (brake)*
- *DO NOT use the Control Panel as an anchor point.*
- *Place the probes in their carrying case.*

1-4-4 Electrical Safety

To minimize shock hazard, the equipment chassis must be connected to an electrical ground. The system is equipped with a three-conductor AC power cable. This must be plugged into an approved electrical outlet with safety ground. If an extension cord is used with the system, make sure that the total current rating of the system does not exceed the extension cord rating.

The power outlet used for this equipment should not be shared with other types of equipment. Both the system power cable and the power connector meet international electrical standards.

1-4-5 Labels Locations

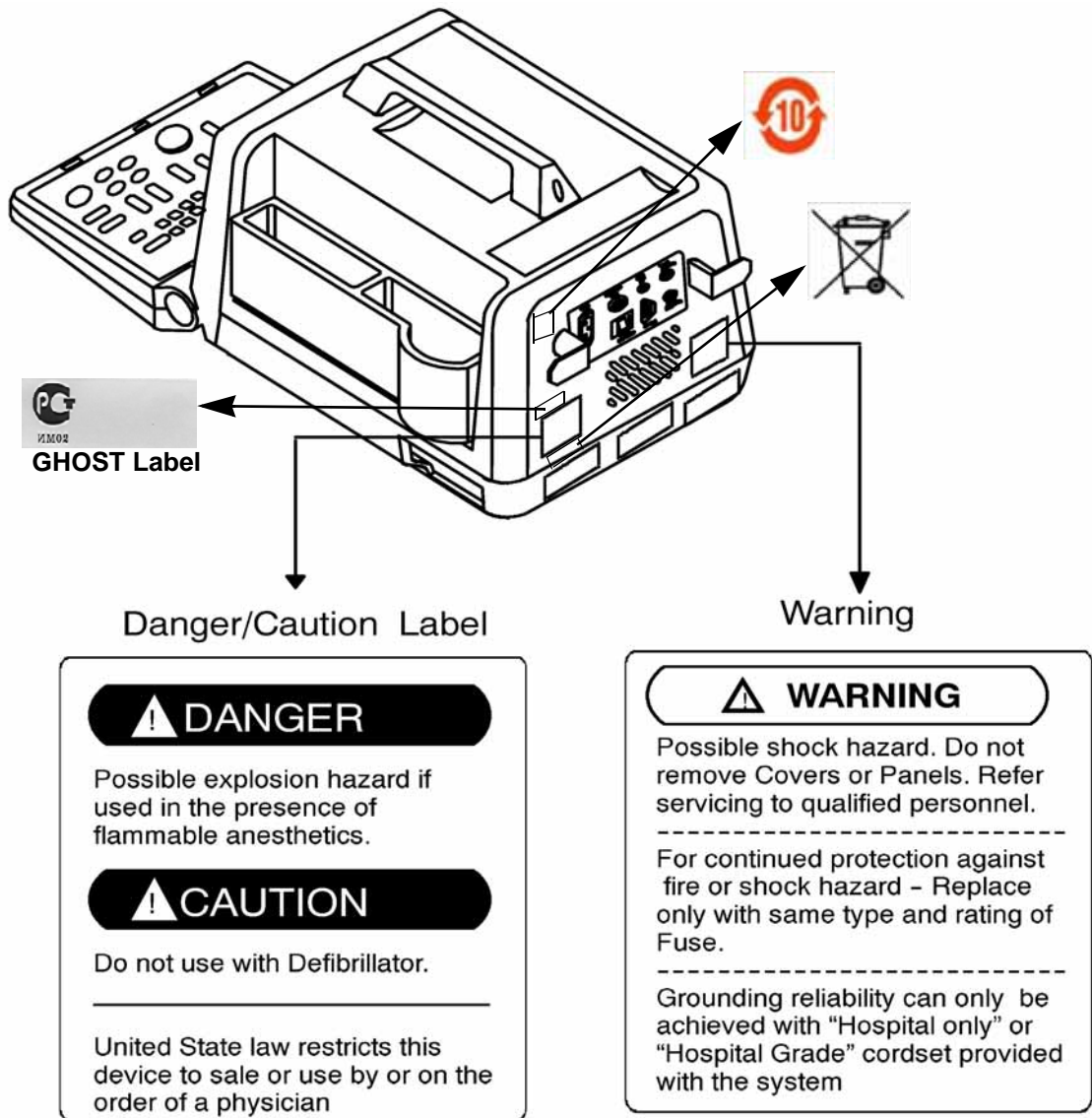

Figure 1-1 Warning Lables

1-3-5 Labels Locations (cont'd)

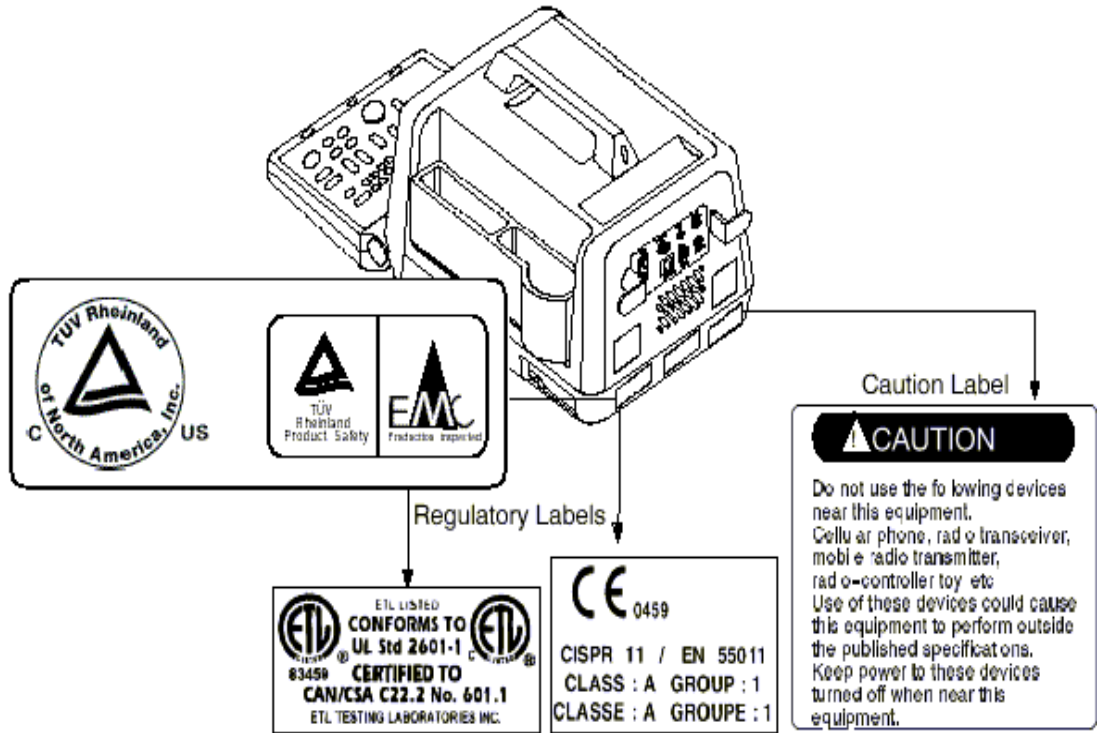

Figure 1-2 Warning Lables

1-3-5 Labels Locations (cont'd)

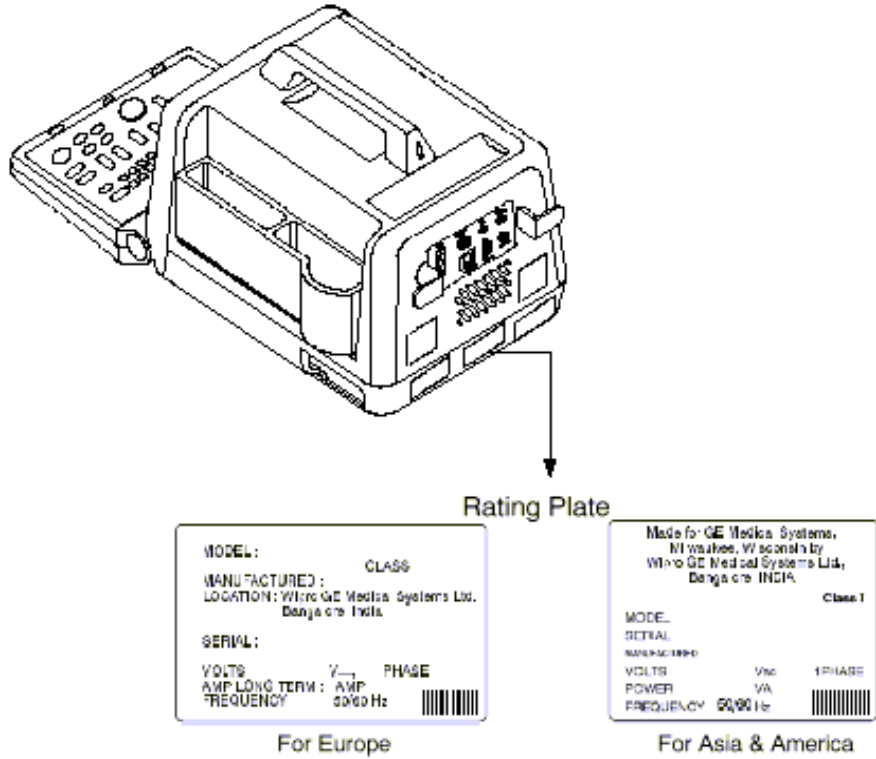

Figure 1-3 Warning Labels

1-3-5 Labels Locations (cont'd)

<p>⚠ WARNING</p> <p>Para la conexión segura de los cables, consulte el manual de usuario de este equipo.</p> <p>For continued protection against the shock hazard, replace only with same type and rating of fuse.</p> <p>Quando se substituir o fusível, use o mesmo tipo e corrente nominal.</p> <p>"Hospital grade" sockets provided with the system.</p>	<p>⚠ AVERTISSEMENT</p> <p>Pour la mise en service et la maintenance, consultez le manuel de l'utilisateur de cet équipement.</p> <p>Pour assurer une protection continue contre les risques de choc électrique, ne remplacez que par des fusibles de même type et de même courant nominal.</p> <p>La sécurité de la connexion à distance doit être assurée par la prise "hôpital" ou "grade hospital" sur le système.</p>	<p>⚠ AVISO</p> <p>Risco de Choque elétrico. Não retire os Tampões nem os Painéis de proteção. Os serviços devem ser feitos por pessoal qualificado.</p> <p>Para uma proteção contínua contra o risco de choque elétrico - substitua sempre o fusível por outro de mesmo tipo e com a mesma corrente.</p> <p>A segurança de conexão com tomada de alta tensão somente deve ser feita com o conjunto de tomadas "Hospital only" ou "Hospital grade" proporcionado com o sistema.</p>
<p>⚠ AVVERTENZA</p> <p>Per la connessione sicura e per la manutenzione, consultare il manuale dell'utente di questo apparecchio.</p> <p>Per prevenire ancora il pericolo di shock elettrico, sostituire i fusibili solo con fusibili dello stesso tipo e con la stessa corrente nominale.</p> <p>Il collegamento a terra può essere effettuato solo con i cavi "Hospital only" (o "ospedale") o "Hospital grade" forniti con il sistema.</p>	<p>⚠ AVISO</p> <p>Risco de descarga e electricidade. No retire as tampas ou os painéis de proteção de choque elétrico.</p> <p>Como a proteção contra as descargas e electricidade é contínua, use só fusíveis do mesmo tipo e corrente nominal.</p> <p>A segurança de la conexión a distancia debe ser asegurada con la toma "Solo hospital" o "Grade hospital" suministrada con el sistema.</p>	<p>⚠ WARNUNG</p> <p>Stromschlaggefahr. Hauben oder Abdeckungen nicht entfernen. Überarbeiten und die Wartung qualifiziertem Personal.</p> <p>Es seien die Sicherung für Stromschlag durch Schutz gegen Feuer oder Stromschlag nur durch den gleichen Typ mit dem gleichen Wert.</p> <p>Die zuverlässige Erdung ist nur mit dem Leitungs- "Hospital only" oder "Hospital grade" gemäß geliefert, dem mit dem System gelieferten wird.</p>
	<p>⚠ 警告</p> <p>電撃の危険あり。カバー（または箱蓋）を取り除かないこと。修理はサービスセンターに依頼すること。</p> <p>火災の危険あり。表示されたヒューズと交換のこと。</p> <p>この機器は「医用コンセント（Hマーク）」に接続したときのみ安全な電圧での動作が保証されます。</p>	

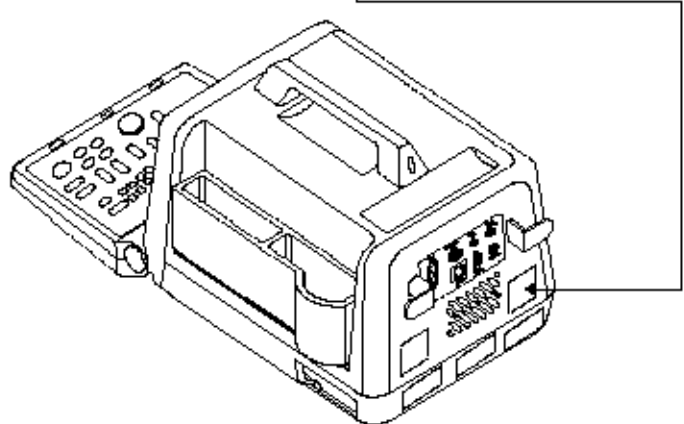

Figure 1-4 Warning Labels

RELEASED UNDER RECOP
 SEHCN



1-3-5 Labels Locations (cont'd)

<p>CAUTION</p> <p>Do not use the following devices near this equipment. Cellular phone, radio transceiver, mobile radio transmitter, radio-controller toy, etc. Use of these devices could cause this equipment to perform outside the published specifications. Keep power to these devices turned off when near this equipment.</p>	<p>ATTENZIONE</p> <p>Non usare i seguenti apparecchi in prossimità di questa apparecchiatura: cellulari, ricetrasmittitore radio, trasmettore radio mobile, giocattoli radiocomandati ecc. L'uso di questi apparecchi potrebbe modificare le specifiche dell'apparecchiatura. Mantenere gli apparecchi interferenti spenti, se in prossimità del sistema.</p>	<p>CUIDADO</p> <p>Não utilize os dispositivos seguintes perto deste equipamento: Telefone celular, radiotransceiver, radiotransmissor móvel, brinquedos de controle remoto, etc. O uso destes dispositivos pode levar o equipamento a ter um desempenho outro que aquele publicado. Desligue estes dispositivos quando estiverem perto deste equipamento.</p>
<p>ATTENTION</p> <p>Ne pas utiliser les appareils suivants à proximité de cet équipement : téléphones mobiles, émetteurs-récepteurs, appareils radiocommandés, etc., cela pouvant entraîner des performances différentes des spécifications annoncées. Maintenir les appareils de ce type hors tension lorsqu'ils se trouvent à proximité du système.</p>	<p>VORSICHT</p> <p>Verwenden Sie folgende Geräte nicht in der Nähe der Anlage: Funktelefon, Funkempfänger, mobiler Funksender, funkgesteuertes Spielzeug usw. Bei Gebrauch dieser Geräte arbeitet die Anlage evtl. nicht entsprechend der veröffentlichten Angaben. Belassen Sie diese Geräte in der Nähe der Anlage ausgeschaltet.</p>	<p>CUIDADO</p> <p>Teléfonos celulares, receptores de radio, juguetes controlados por transmisores de radio móviles, etc. El uso de estos dispositivos puede hacer que el equipo funcione fuera de las especificaciones publicadas. Mantenga apagados dichos dispositivos cuando estén cerca del sistema.</p>

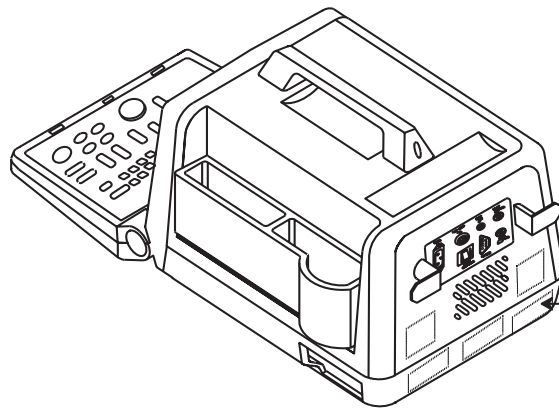

Figure 1-5 Warning Labels

RELEASED UNDER DISCOVERY
 SECTION 1-3-5

1-3-5 Labels Locations (cont'd)

<p>⚠ DANGER Possible explosion hazard if used in the presence of flammable anesthetics.</p> <p>⚠ CAUTION Do not use with Defibrillator. United States law restricts this device to sale or use by or on the order of a physician.</p> <p>⚠ DANGER Risque d'explosion. Ne pas employer en présence d'anesthésiques inflammables.</p> <p>⚠ ATTENTION Ne pas faire fonctionner avec un défibrillateur.</p>	<p>⚠ PELIGRO Riesgo de explosión. No emplear en presencia de anestésicos inflamables.</p> <p>⚠ ATENCION No hacer funcionar con un desfibrilador.</p> <p>⚠ PERIGO Possível explosão se usado na presença de anestésicos inflamáveis.</p> <p>⚠ ATENÇÃO Não use com desfibrilador.</p> <p>⚠ 危険 爆発の危険あり。引火性麻酔剤のある場所では使用しないこと。</p> <p>⚠ 注意 除細動器との併用はしないこと。</p>	<p>⚠ PERICOLO Possibilità di esplosione se il sistema è usato in presenza di gas anestetici infiammabili.</p> <p>⚠ ATTENZIONE Non fare funzionare con un defibrillatore.</p> <p>⚠ VORSICHT Explosionsgefahr! Nicht in Gegenwart brennbarer Narkosegase verwenden.</p> <p>⚠ ACHTUNG Nicht zusammen mit einem Defibrillator betreiben.</p>
--	---	--

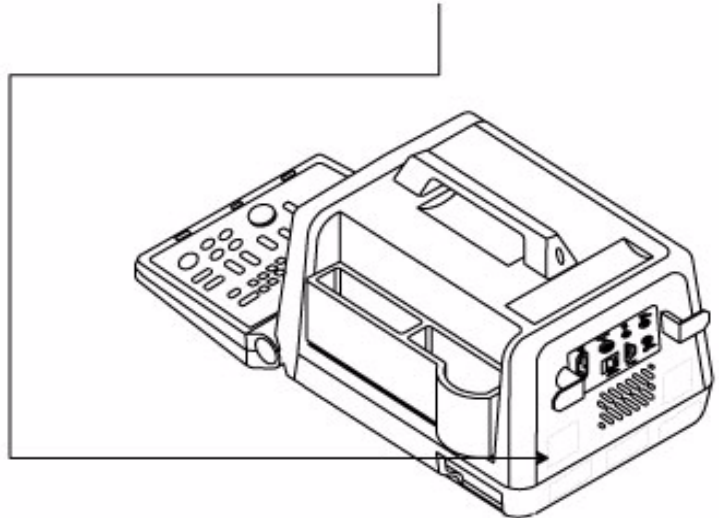

Figure 1-6 Warning Lables

1-4-6 Dangerous Procedure Warnings

Warnings, such as the example below, precede potentially dangerous procedures throughout this manual. Instructions contained in the warnings must be followed.



DANGER

DANGEROUS VOLTAGES, CAPABLE OF CAUSING DEATH, ARE PRESENT IN THIS EQUIPMENT. USE EXTREME CAUTION WHEN HANDLING, TESTING AND ADJUSTING.



WARNING

EXPLOSION WARNING: DO NOT OPERATE THE EQUIPMENT IN AN EXPLOSIVE ATMOSPHERE. OPERATION OF ANY ELECTRICAL EQUIPMENT IN SUCH AN ENVIRONMENT CONSTITUTES A DEFINITE SAFETY HAZARD.



WARNING

DO NOT SUBSTITUTE PARTS OR MODIFY EQUIPMENT: BECAUSE OF THE DANGER OF INTERDICTING ADDITIONAL HAZARDS, DO NOT INSTALL SUBSTITUTE PARTS OR PERFORM ANY UNAUTHORIZED MODIFICATION OF THE EQUIPMENT.

1-4-7 Lockout/Tagout Requirements (For USA Only)

Follow OSHA Lockout/Tagout requirements by ensuring you are in total control of the plug.

1-4-8 Classification

Type of protection against electric shock: Class I EQUIPMENT *1

Degree of protection against electric shock: Type BF EQUIPMENT**2

1.) *Class I EQUIPMENT

EQUIPMENT in which protection against electric shock does not rely on BASIC INSULATION only, but which includes an additional safety precaution in that means are provided for the connection of the EQUIPMENT to the protective earth conductor in the fixed wiring of the installation in such a way that ACCESSIBLE METAL PARTS cannot become LIVE in the event of a failure of the BASIC INSULATION.

2.) **Type BF EQUIPMENT*

Type B EQUIPMENT with a F-TYPE isolated applied part providing a degree of protection against electric shock to such a degree that the allowable PATIENT LEAKAGE CURRENT under SINGLE FAULT CONDITIONS is not exceeded when 1.1 times the highest rated MAINS VOLTAGE is applied between the APPLIED PART and earth.

Section 1-5 EMC, EMI, and ESD

1-5-1 Electromagnetic Compatibility (EMC)

Electromagnetic compatibility describes a level of performance of a device within its electromagnetic environment. This environment consists of the device itself and its surroundings including other equipment, power sources and persons with which the device must interface. Inadequate compatibility results when a susceptible device fails to perform as intended due to interference from its environment or when the device produces unacceptable levels of emission to its environment. This interference is often referred to as radio-frequency or electromagnetic interference (RFI/EMI) and can be radiated through space or conducted over interconnecting power of signal cables. In addition to electromagnetic energy, EMC also includes possible effects from electrical fields, magnetic fields, electrostatic discharge and disturbances in the electrical power supply.

1-5-2 CE Compliance

The LOGIQ™ 100 PRO unit conforms to all applicable conducted and radiated emission limits and to immunity from electrostatic discharge, radiated and conducted RF fields, magnetic fields and power line transient requirements.

Applicable standards are: 47CFR Part 18, IEC 601–1–2, and 806–13.

For CE Compliance, it is critical that all covers, screws, shielding, gaskets, mesh, clamps, are in good condition, installed tightly without skew or stress. Proper installation following all comments noted in this service manual is required in order to achieve full EMC performance.

1-5-3 EMC Performance

All types of electronic equipment may characteristically cause electromagnetic interference with other equipment, either through air or connecting cables. The term EMC (Electromagnetic Compatibility) indicates capability of the equipment, which curbs electromagnetic influence from other equipment and at the same time does not affect other equipment with similar electromagnetic radiation from itself.

This product is designed to fully comply with the EN60601-1-2 (IEC601-1-2), in Medical electrical equipment EMC regulations.

Proper installation following this service manual is required in order to achieve the full EMC performance of the product.

The product must be installed as stipulated in 1-4-4, Notice upon Installation of Product.

In case of issues related to EMC, please follow procedures stated in 1-4-6, Countermeasures against EMC-related Issues.

1-5-4 Notice Upon Installation of Product

- 1.) Use either power supply cords provided by GEMS or ones approved by GEMS. Products equipped with power source plug should be plugged into the fixed power socket which has the protective grounding conductor
- 2.) Connect a three-pin plug to a three-pin socket without using a three-pin-to-two-pin converter.
- 3.) Keep the equipment as far as possible from other electronic equipment.
- 4.) Be sure to use the only cables provided by GEMS or ones approved by Wipro GE. Install the unit/peripherals as per the installation procedure provided in Chapter 3 - INSTALLATION. The layout of the LOGIQ™ 100 PRO & other peripherals should be as per installation procedures described in Chapter 3 - INSTALLATION.

1-5-5 General Notice

- 1.) Designation of Peripheral Equipment Connectable to this Product. The peripheral which conforms to EN60601-1-2 (IEC601-1-2), can be connected up to the LOGIQ™ 100 PRO without compromising its EMC performance. Failure to comply with the above instruction may result in poor EMC performance of the product.
- 2.) **Notice against User Modification:** Do not modify this product. Unilateral user modification may cause degradation in EMC performance. Modification of the product includes:
 - a.) Changes in cables (length, material, wiring etc.)
 - b.) Changes in system installation/layout
 - c.) Changes in system configuration/components
 - d.) Changes in means of fixing system/parts (cover open/close, cover screwing)
- 3.) Operate the system with all covers closed. If you open any cover for some reason, be sure to shut it before starting/ resuming operation. Operating the system with any cover open may affect EMC performance.

1-5-6 Countermeasures against EMC related Issues

Generally it is very difficult to handle with issues related to EMC. It is time consuming and expensive. General counter measures for Electromagnetic interference with other equipment

- 1.) Electromagnetic interference may be reduced by positioning other equipment far away from the system.
- 2.) Electromagnetic interference may be reduced by changing the relative location (installation angle) of the system and other equipment.
- 3.) Electromagnetic interference may be reduced by changing wiring locations of power/signal cables of other equipment.
- 4.) Electromagnetic influence may be reduced by altering the path of power supply for other equipment.

1-5-7 Notice on Service

Ensure all screws are tight after servicing. Loose screws may cause degradation in EMC performance.



CAUTION

Do not use the following devices near the LOGIQ™ 100 PRO system. Devices which intrinsically transmit radio waves such as cellular phone, radio transceiver, mobile radio transmitter radio-controlled toy, etc. Use of these devices could cause the LOGIQ™ 100 PRO system to perform outside the published specifications. Keep power to these devices turned OFF when near the system. Medical staff in charge of the LOGIQ™ 100 PRO system is required to instruct technicians, patients and other people who may be around the system to fully comply with the above regulation

1-5-8 Electrostatic Discharge (ESD) Prevention

DO NOT TOUCH ANY BOARDS WITH INTEGRATED CIRCUITS PRIOR TO TAKING THE NECESSARY ESD PRECAUTIONS:



WARNING

- 1.) *Always connect yourself, via an arm-wrist strap, to the advised esd connection point located on the rear of the scanner (to the right of the power connector).*
- 2.) *Follow general guide lined for handling of electrostatic sensitive equipment.*

Section 1-6 Customer Assistance

This system is not repairable by the customer. If this equipment does not work as indicated in the Operator's Manual, please contact your service support center. If the service engineer needs additional information to repair this equipment, please contact any relevant addresses given below:

1-6-1 System Manufacturer

WIPRO GE HEALTHCARE - INDIA
WIPRO GE HEALTHCARE PVT., LTD. ULTRASOUND GROUP. PLOT # 4, KADUGODI INDUSTRIAL AREA, SADARAMANGALA, BANGALORE 560067, INDIA TEL: (91) 80-2845-2923 FAX:(91) 80-2845-2924 Ultrasound Tech Support - India : +(91) 1800114567

Table 1-6 System Manufacturer

1-6-2 Contact Information

Location	Phone Number
USA/CANADA: GE Medical systems Ultrasound Service Engineering, 4855 W. Electric Avenue Milwaukee, WI 53219 Customer Answer Center	TEL: 1 800-437-1171 1-800-682-5327 1-262-524-5698 FAX: +1- 414-647-4125
LATIN AMERICA: GE Medical systems Ultrasound Service Engineering 4855 W. Electric Avenue Milwaukee, WI 53219 Customer Answer Center	TEL: (1) 262-524-5300 TEL: (1) 262-524-5698 FAX: +1- 414-647-4125
ASIA(Singapore/Japan): GE Ultrasound Asia (Singapore) Service Department - Ultrasound 298 Tiong Bahru Road #15-01/06 Central Plaza Singapore 169730 Ultrasound Tech Support - JAPAN	TEL: 65-291 8528 (81) 426-48-2950 FAX: 65-272-3997 FAX: (81) 426-482902 +(81) 426482944
ASIA(China/India/Korea/SEA): Ultrasound Tech Support - CHINA Ultrasound Tech Support - INDIA Ultrasound Tech Support - KOREA Ultrasound Tech Support - SEA	+(86) 8008108188 +(91) 1800114567 +(82) 262013585 +(65) 62773444
EUROPE: GE Ultraschall Deutschland GmbH & Co. KG BeethovenstraBe 239 Postfach 11 05 60, D-42665 Solingen Germany	TEL:+49 212 2802 208 +49 212 2802 207 FAX: (49) 212.28.02.431
Ultrasound Tech Support - ANZ	+(61) 1800647855

Table 1-1 Service Contact Information

UNCLASSIFIED//FOR OFFICIAL USE ONLY

Chapter 2 Pre Installation

Section 2-1 Overview

2-1-1 Purpose of Chapter 2

This chapter provides the information required to plan and prepare for the installation of a LOGIQ™ 100 PRO. Included are descriptions of the facility and electrical needs to be met by the purchaser of the unit. A checklist is also provided at the end of this section to help determine whether the proper planning and preparation is accomplished before the actual equipment installation is scheduled.

CONTENTS IN CHAPTER 2

Section	Description	Page Number
2-1	Overview	2-1
2-2	General Console Requirements	2-1

Table 2-1 Contents in Chapter 2

Section 2-2 General Console Requirements

2-2-1 Console Environmental Requirements

Operating temperature:	10 to 40 °C
Storage temperature:	-10 to 60 °C
Humidity:	30% to 75% rH non-condensing

Table 2-2 Environmental Specifications for LOGIQ™ 100 PRO Scanners

2-2-1-1 Lighting

Bright light is needed for system installation, updates and repairs. However, operator and patient comfort may be optimized if the room light is subdued and indirect. Therefore a combination lighting system (dim/bright) is recommended. Keep in mind that lighting controls and dimmers can be a source of EMI which could degrade image quality. These controls should be selected to minimize possible interference.

2-2-2 Electrical Requirements

2-2-2-1 LOGIQ™ 100 PRO Power Requirements

Electrical Specifications for LOGIQ™ 100 PRO.

GE Healthcare Hcat number	Voltage	Tolerances	Current	Frequency
H41072LA,H41072LB, H41072LC,H41072LD, H41072LE,H41072LF, H41072LS	100-230 VAC	±10%	0.9 -1.8 A Max.	50-60 Hz

Table 2-3 Electrical Specifications for LOGIQ™ 100 PRO

2-2-2-2 Site Circuit Breaker

It is recommended that the branch circuit breaker for the machine be readily accessible.



CAUTION

POWER OUTAGE MAY OCCUR. The LOGIQ™ 100 PRO requires a dedicated single branch circuit. To avoid circuit overload and possible loss of critical care equipment, make sure you DO NOT have any other equipment operating on the same circuit.

2-2-2-3 Site Power Outlets

A dedicated AC power outlet must be within reach of the unit without extension cords. Other outlets adequate for the external peripherals, medical and test equipment needed to support this unit must also be present within 1 m (3.2 ft.) of the unit. Electrical installation must meet all current local, state, and national electrical codes.

2-2-2-4 Unit Power Plug

If the unit arrives without a power plug, or with the wrong plug, you must contact your GE dealer or the installation engineer must supply what is locally required.

2-2-2-5 Power Stability Requirements

Voltage drop-out

Max 10 ms.

Power Transients

(All applications)

Less than 25% of nominal peak voltage for less than 1 millisecond for any type of transient, including line frequency, synchronous, asynchronous, or aperiodic transients.

2-2-3 EMI Limitations

Ultrasound machines are susceptible to Electromagnetic Interference (EMI) from radio frequencies, magnetic fields, and transients in the air or wiring. They also generate EMI. The LOGIQ™ 100 PRO complies with limits as stated on the EMC label. However there is no guarantee that interference will not occur in a particular installation.

Possible EMI sources should be identified before the unit is installed.

Electrical and electronic equipment may produce EMI unintentionally as the result of a defect. These sources include:

- medical lasers,
- scanners,
- cauterizing guns,
- computers,
- monitors,
- fans,
- gel warmers,
- microwave ovens,
- light dimmers
- portable phones.

The presence of a broadcast station or broadcast van may also cause interference. See Table 2-4 for EMI Prevention tips.

2-2-3 EMI Limitations (cont'd).

EMI Rule	Details
Be aware of RF sources	Keep the unit at least 5 meters or 15 feet away from other EMI sources. Special shielding may be required to eliminate interference problems caused by high frequency, high powered radio or video broadcast signals.
Ground the unit	Poor grounding is the most likely reason a unit will have noisy images. Check grounding of the power cord and power outlet.
Replace all screws, RF gaskets, covers, cores	After you finish repairing or updating the system, replace all covers and tighten all screws. Any cable with an external connection requires a magnet wrap at each end. Install the shield over the front of card cage. Loose or missing covers or RF gaskets allow radio frequencies to interfere with the ultrasound signals.
Replace broken RF gaskets	If more than 20% or a pair of the fingers on an RF gasket are broken, replace the gasket. Do not turn on the unit until any loose metallic part is removed.
Do not place labels where RF gaskets touch metal	Never place a label where RF gaskets meet the unit. Otherwise, the gap created will permit RF leakage. Or, if a label has been found in such a position, move the label.
Use GE specified harnesses and peripherals	The interconnect cables are grounded and require ferrite beads and other shielding. Also, cable length, material, and routing are all important; do not change from what is specified.
Take care with cellular phones	Cellular phones may transmit a 5 V/m signal; that could cause image artifacts.
Properly dress peripheral cables	Do not allow cables to lie across the top of the card cage or hang out of the peripheral bays. Loop the excess length for peripheral cables inside the peripheral bays. Attach the monitor cables to the frame.

Table 2-4 EMI Prevention/abatement

2-2-4 Probes Environmental Requirements

	ELECTRONIC	PAMPTE
Operation:	10 to 40 °C	5 to 42.7 °C
Storage:	-20 to 50 °C	-20 to 50 °C
Temperatures in degrees C, conversion to degrees F = °C*(9/5) + 32)		

Table 2-5 Operation and Storage Temperatures for Probes.

 **NOTICE: SYSTEMS AND ELECTRONIC PROBES ARE DESIGNED FOR STORAGE TEMPERATURES OF -20 TO + 50 deg C. WHEN EXPOSED TO LARGE TEMPERATURE VARIATIONS, THE PRODUCT SHOULD BE KEPT IN ROOM TEMPERATURE FOR 10 HOURS BEFORE USE.**

2-2-5 Time and Manpower Requirements

Site preparation takes time. Begin Pre installation checks as soon as possible, if possible, six weeks before delivery, to allow enough time to make any changes.

2-2-6 Checklist for Installation

2-2-6-1 Checklist for Installation

Procedures	Paragraph	Initials
Observe Warnings	Section 3-1-3	
Unpack LOGIQ™ 100 PRO	Section 3-2	
Assemble LOGIQ™ 100 PRO	Section 3-4	
Perform Functional Checks	Chapter 4-3	
Perform Electrical Safety Tests	Chapter 10-6	

Table 2-6 Checklist for Installation

Your Notes:

RELEAS
SECTION

Chapter 3 Installation

Section 3-1 Overview

3-1-1 Purpose of Chapter 3

This chapter contains information needed to install the unit. Included are references to a procedure that describes how to receive and unpack the equipment and how to file a damage or loss claim. How to prepare the facility and unit of the actual installation, and how to check and test the unit, probes, and external peripherals for electrical safety are included in this procedure. Also included in this section are guidelines for transporting the unit to a new site.

CONTENTS IN CHAPTER 3

Table 3-1 Contents in Chapter 3

Section	Description	Page Number
3-1	Overview	3-1
3-2	Receiving and Unpacking the Equipment	3-3
3-3	Preparing for Installation	3-5
3-5	Completing the Installation	3-6
3-6	System Configuration	3-17
3-7	Paperwork	3-28

3-1-2 Average Installation Time

Description	Average Installation Time	Comments
Unpacking the scanner	20 Minutes	
Scanner wo/options	40 Minutes	Dependant on the configuration that is required

Table 3-2 Average Installation Time

3-1-3 Safety Reminders



DANGER

WHEN USING ANY TEST INSTRUMENT THAT IS CAPABLE OF OPENING THE AC GROUND LINE (I.E., METER'S GROUND SWITCH IS OPEN), DON'T TOUCH THE UNIT!



CAUTION

If the unit is very cold or hot, do not turn on its power until it has had a chance to acclimate to its operating environment.



CAUTION

To prevent electrical shock, connect the unit to a properly grounded power outlet. Do not use a three to two prong adapter. This defeats safety grounding.



CAUTION

Do NOT wear the ESD wrist strap when you work on live circuits and more than 30 V peak is present.



CAUTION

Do not use a 20 Amp to 15 Amp adapter on the 120 Vac unit's power cord. This unit requires a dedicated 20 A circuit and can have a 15A plug if the on board peripherals do not cause the unit to draw more than 14.0 amps.



CAUTION

Do not operate this unit unless all board covers and frame panels are securely in place. System performance and cooling require this.



CAUTION

OPERATOR MANUAL(S)

The User Manual(s) should be fully read and understood before operating the LOGIQ™ 100 PRO and kept near the unit for quick reference.



ACOUSTIC OUTPUT HAZARD

Although the ultrasound energy transmitted from the LOGIQ™ 100 PRO probe is within AIUM/NEMA standards, avoid unnecessary exposure. Ultrasound energy can produce heat and mechanical damage.

Section 3-2 Receiving and Unpacking the Equipment

Please read that procedure before packing/unpacking the LOGIQ™ 100 PRO.

We strongly advise you to store the LOGIQ™ 100 PRO packing material in undamaged condition in case of future transportation.

- 1.) Cut the two straps wrapped around the box. Refer Figure 3-1.
- 2.) Remove the adhesive tape. Refer Figure 3-1
- 3.) Open the carton flaps. Refer Figure 3-2.
- 4.) Remove the Operator Manual, Service Manual, Gel Bottle, Power Cord and other accessories kept on either side of the equipment. Refer Figure 3-3.
- 5.) Lift the system (wrapped with stretch film) out of the box along with the packaging buffers. Refer Figure 3-2
- 6.) Slide the packaging buffers out to free the system.
- 7.) Remove the stretch film which is wrapped around the system. Refer Figure 3-2

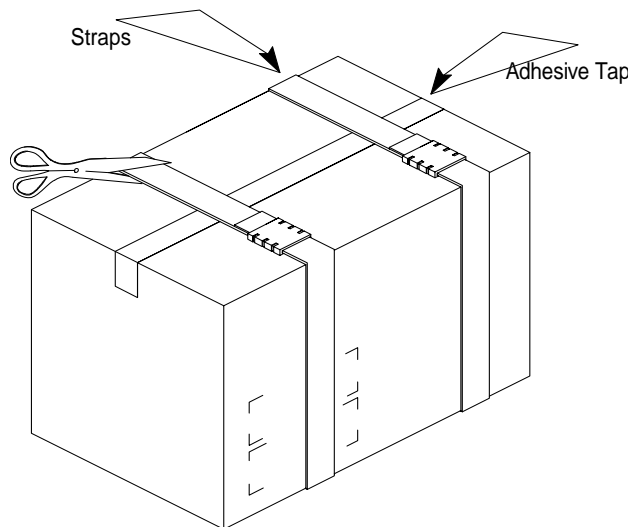

Figure 3-1 Unpacking LOGIQ™ 100 PRO

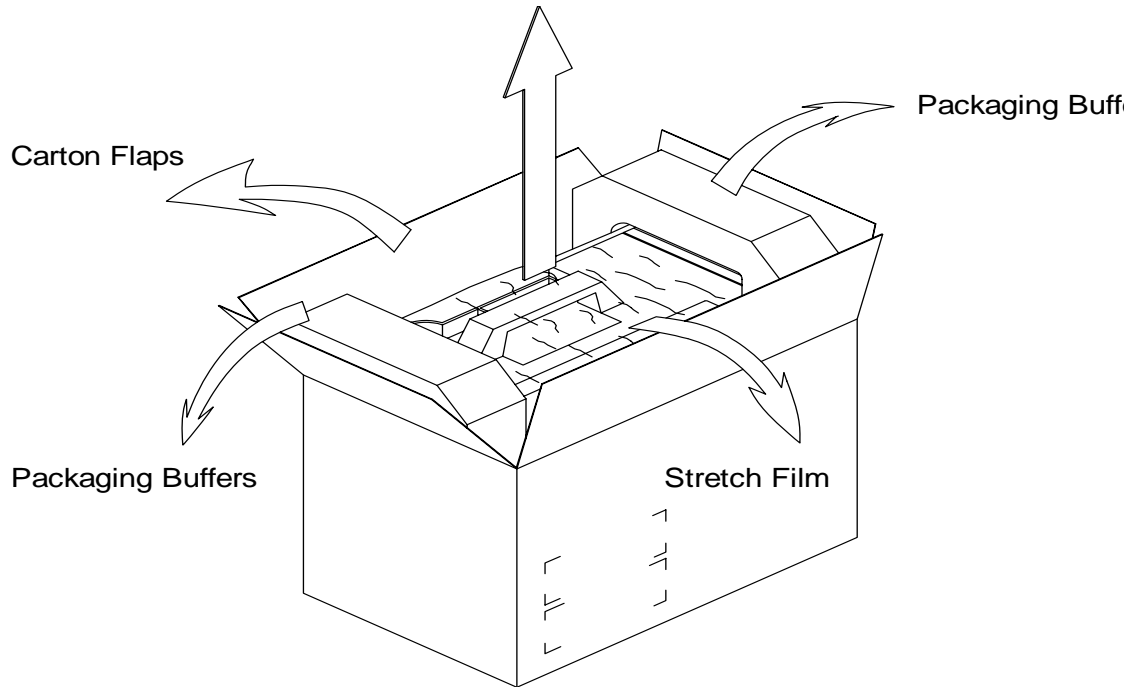

Figure 3-2 Unpacking LOGIQ™ 100 PRO

Note: The Service Manual, Operator Manual, Advanced Reference Manual, Gel Bottle and Power Cord are wrapped in bubble sheet and are kept along the sides of the corrugated carton box. Refer Illustration below for details

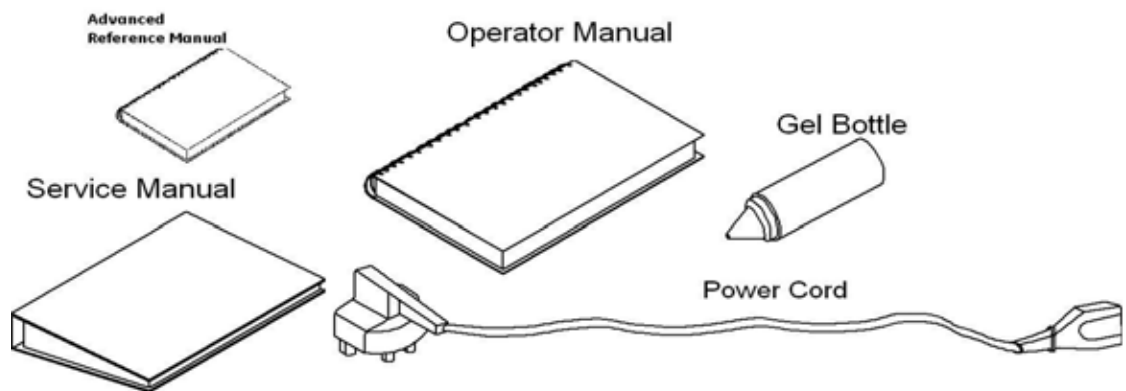

Figure 3-3 Unpacking LOGIQ™ 100 PRO

RELEASED UNDER E.O. 13526
SECTION 1.4

Section 3-3 Preparing for Installation

3-3-1 Physical Inspection

3-3-1-1 Systems Voltage Settings

- Verify that the scanner is set to the correct voltage.
The Voltage settings for the LOGIQ™ 100 PRO Scanner is found on a label on the rear of the system.



WARNING

CONNECTING A LOGIQ™ 100 PRO SCANNER TO THE WRONG VOLTAGE LEVEL WILL MOST LIKELY DESTROY THE SCANNER.

3-3-1-2 Video Formats

Check that the video format is set to the locally used video standard, NTSC or PAL.

3-3-2 EMI Protection

This unit has been designed to minimize the effects of Electro Magnetic Interference (EMI). Many of the covers, shields, and screws are provided primarily to protect the system from image artifacts caused by this interference. For this reason, it is imperative that all covers and hardware are installed and secured before the unit is put into operation.

Section 3-4 Assembling LOGIQ™ 100 PRO



CAUTION

It is strongly recommended that the equipment should be installed on an even and hard surface to provide proper cooling, as the vents for air circulation are on the bottom cover.

3-4-1 Installation of the System

- 1.) Locate, remove and unpack the probes located in the separate container.
- 2.) Make sure that system power is OFF before connecting or disconnecting the probe.
- 3.) Secure the probe to the receptacle as follows. Refer to Fig 3-4
 - a.) Ensure probe `twist lock' lever points towards the top of the probe connector.
 - a.) Install probe connector on the receptacle guide pin until it touches the receptacle mating surface.
 - a.) Twist the probe connector `twist lock' lever in the clockwise direction to lock it in place (Twist the lever anticlockwise direction to disconnect the probe).
- 4.) Connect the LOGIQ™ 100 PRO Power cable's female part to the power connector located on the rear panel and the male part to a hospital grade power socket of a proper voltage. Never use a three-to-two pin adapter; this defeats the purpose of safety ground.
- 5.) Unlock the keyboard by pressing the lock release on top of the system.



CAUTION

Do not move or lift the unit, holding the keyboard alone.

Assembling LOGIQ™ 100 PRO (Contd.,)

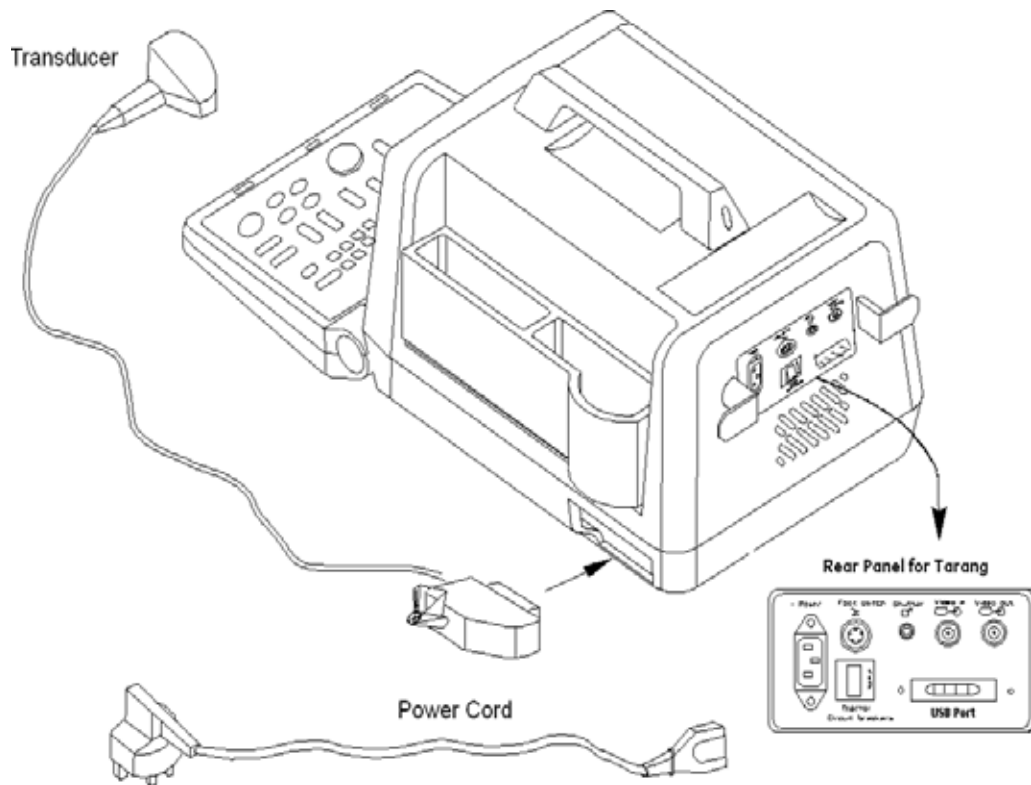

Figure 3-4 Assembling LOGIQ™ 100 PRO

Section 3-5 Completing the Installation

3-5-1 Transducer Connection

- 1.) Connect a transducer to transducer receptacle as follows, Refer to fig 3-4
 - A.) Ensure that the transducer twist lock lever points towards the top of the probe connector.
 - B.) Insert the transducer connector on the receptacle guide pin until it touches the receptacle mating surface.
 - C.) Twist the transducer twist lock lever in the clockwise direction to lock it in place. Twist the lever in anti clockwise direction to disconnect the transducer.

Note: It is not necessary to turn OFF power to connect or disconnect a transducer.

- 2.) Connect the main power cable to a hospital grade power receptacle with the proper rated voltage. Never use a three-to-two prong adapter; this defeats the safety ground.

3.5.1.1 System Software Installation through USB Thumbdrive:

- 1.) Switch OFF the LOGIQ™ 100 PRO unit. Connect the USB thumb drive to the USB port provided in the rear panel.
- 2.) Switch ON the unit and wait till the system boots up completely and the B mode image is seen.
- 3.) Now Switch OFF the LOGIQ™ 100 PRO unit and switch ON again.
- 4.) The system should display the latest version of software that was loaded through the USB.

The USB thumb drive would have the latest software in it, which would be sent by the Manufacturer before software upgrade.

Whenever Upgrade of LOGIQ™ 100 PRO is done at field, Please ensure patient data back up is done before upgrading the machine.

Do not remove the USB thumb drive when the image is getting transferred.

3-5-2 Installation of Optional Accessories

- 1.) Unpack the foot switch and connect it to the connector on the rear panel. (Refer Figure 3-5)
- 2.) Connect the VCR to a suitable power outlet. Using the BNC to BNC cable connect the Video Out on the rear panel of LOGIQ™ 100 PRO to the Video IN of the VCR.
- 3.) Connect the Video Graphic Printer (VGP) to a suitable power outlet. Using the BNC to BNC cable connect the Video Out on the rear panel of LOGIQ™ 100 PRO to the Video IN of the VGP. Connect the shutter cable from the VGP printer to the rear panel of the Logiq 100 PRO.
- 4.) The images and report pages of the Logiq 100 PRO can be printed on HP Laser jet printer (Model HP1020) through the USB port provided on the rear panel. Images can be transferred to a PC using USB Thumb drive.

Note: The LOGIQ™ 100 PRO has only one Video Out connection Therefore either a VGP or a VCR only can be connected at a time

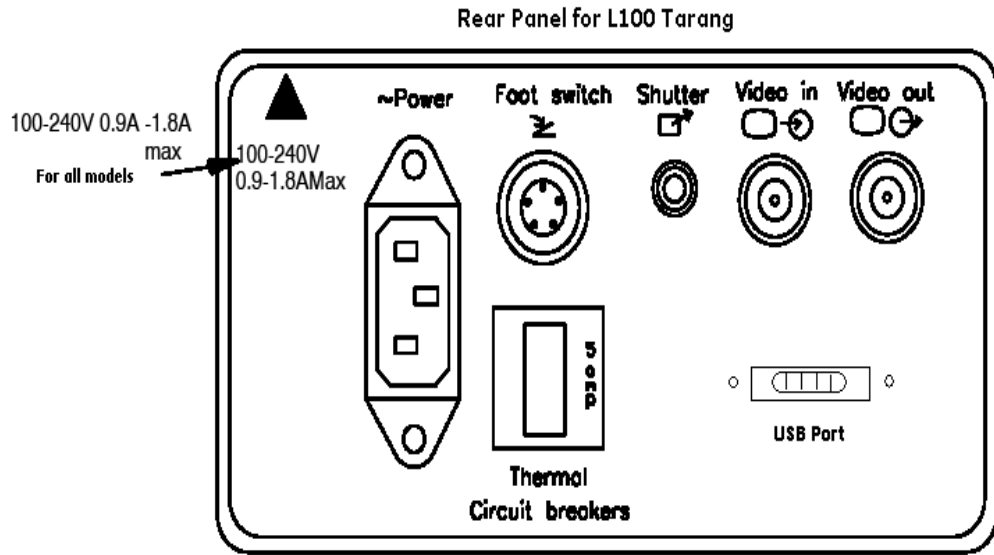

Figure 3-5 Installation of Accessories

3-5-3 Installation of Two Probe Adapter & LOGIQ α200 Probe Adapter (Optional)

- 1.) Remove the adhesive tape to open the flaps of two probe port or LOGIQ α 200 Probe Adapter box
- 2.) Remove the PU Foams inside the two probe port or LOGIQ α 200 Probe Adapter box (Refer Figure 3-6)
- 3.) Take out the two probe port or LOGIQ α 200 Probe Adapter (Refer Figure 3-6)

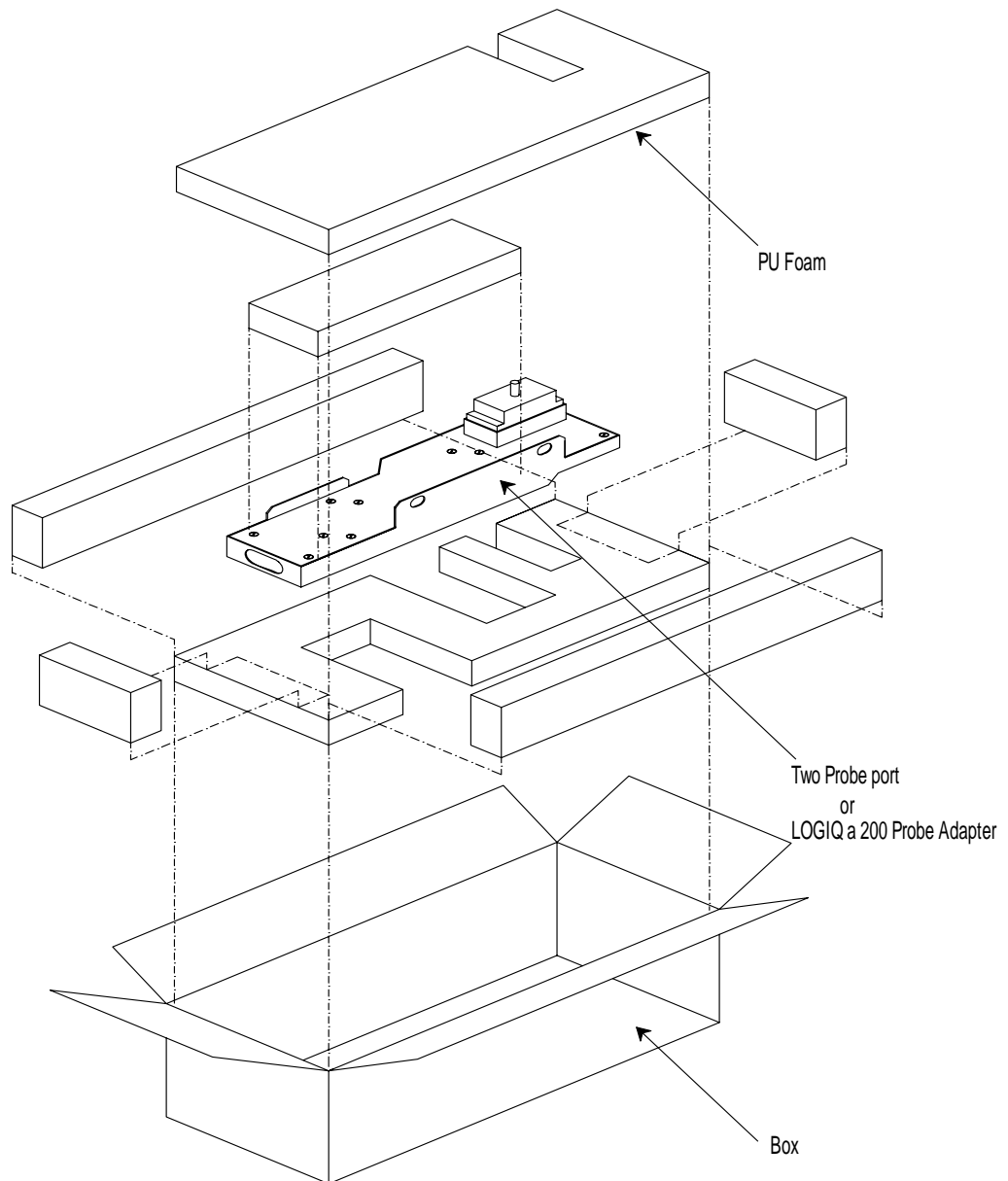

Figure 3-6 Unpacking Two Probe Adapter or LOGIQ α200 Probe Adapter

Note: *The two probe port or LOGIQ α 200 Probe Adapter can be connected to or disconnected from the system at any time regardless of whether the system is powered ON or OFF.*

Installation of Two Probe Adapter & LOGIQ α200 Probe Adapter (Optional) (contd.,)

- 4.) Ensure that no probe is connected to the system. If connected remove it first.
- 5.) Remove the probe holder by lifting it vertically up
- 6.) Make sure that the two probe port or LOGIQ α 200 Probe Adapter lock points to the 12 o'clock position.
- 7.) Align the Two Probe Port or LOGIQ α 200 Probe Adapter Connector with the System Probe Port and carefully push it in.
- 8.) Align the slots on the upper flange to its counterparts on the top cover of the system.
- 9.) Turn the Two Probe Port or LOGIQ a 200 Lock to the 3 o'clock position to secure the Two Probe Port or LOGIQ a 200 Probe Adapter to the system.
- 10.) Carefully replace the probe holder to its place and press firmly till the projections at the bottom fit into the slots in the upper flange and the system.

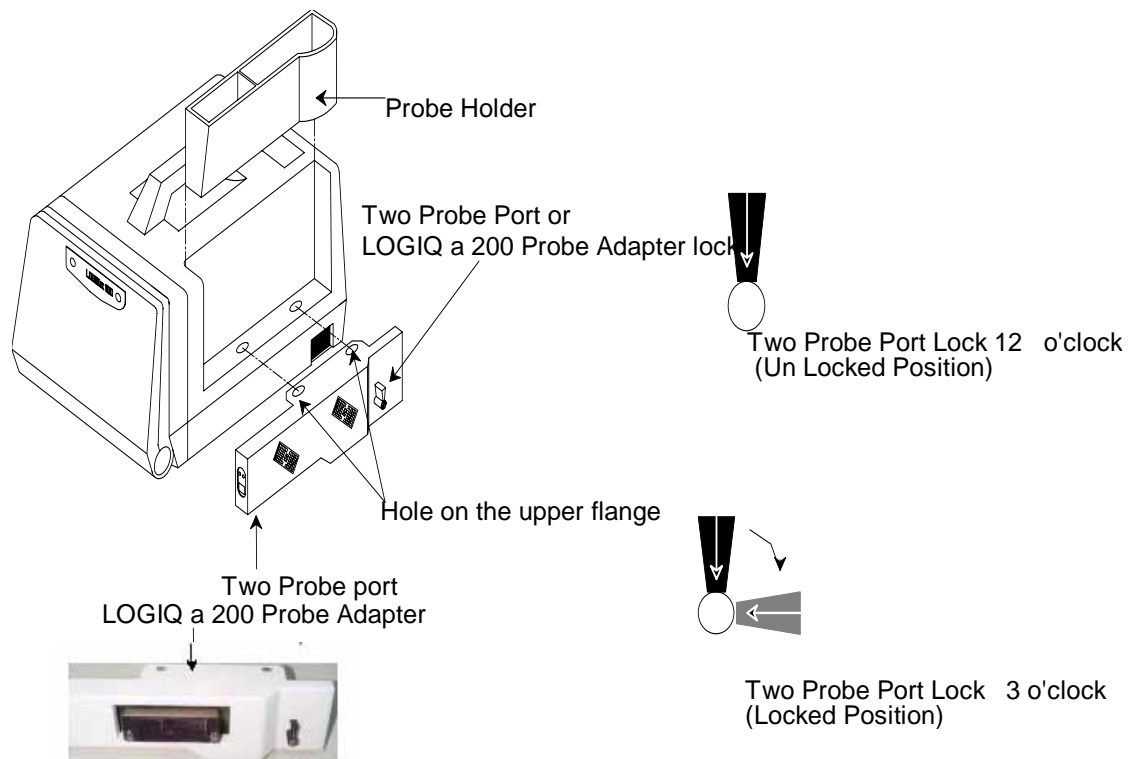

Figure 3-7 Installing Two Probe Port or LOGIQ 200 Probe Adapter

3-5-4 Installation of LOGIQ™ 100 PRO with Global or Modular Trolley

Note: LOGIQ™ 100 PRO has two types of Trolleys, the Global Trolley and the Modular Trolley. The Global Trolley comes in the assembled form and the Modular Trolley comes in a modular form which needs assembly at field.

- 1.) Unpack the global trolley packed in a wooden box by opening the top cover, refer Figure 3-8 (trolley which is inside the box is seen in the diagram).

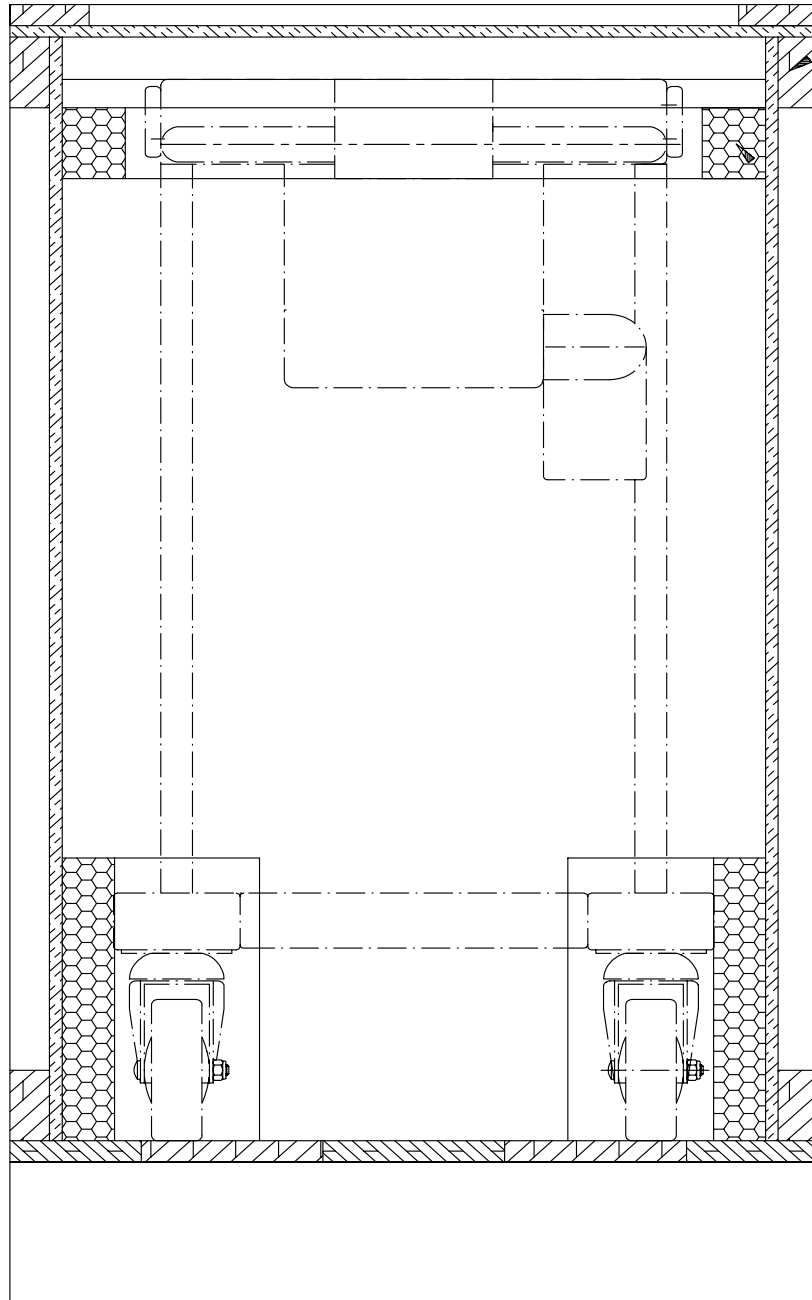

Figure 3-8 Global Trolley Unpacking

Installation of LOGIQ™ 100 PRO with Global or Modular Trolley (Contd.,)

- 2.) Unpack the Modular Trolley packed in a box by opening the top cover, refer Figure 3-8

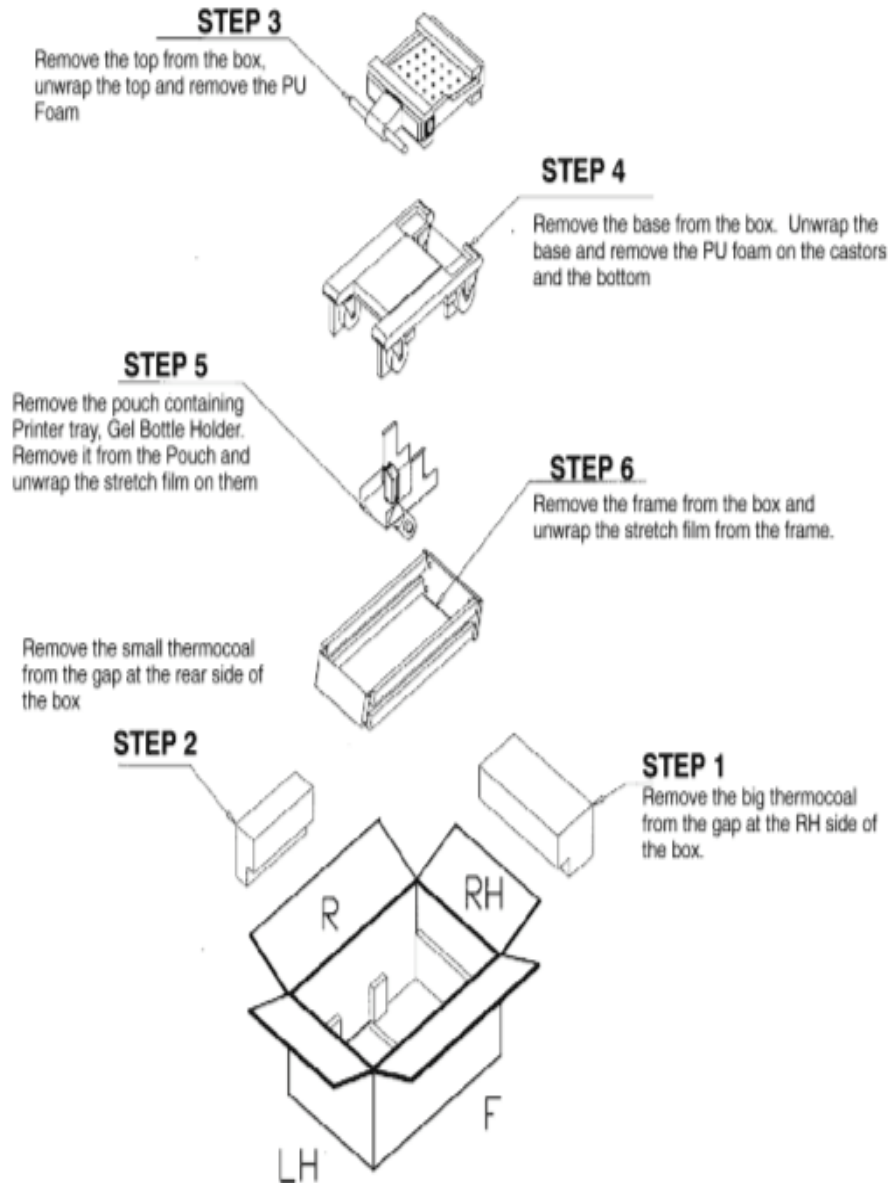

Figure 3-9 Modular Trolley Unpacking

Installation of LOGIQ™ 100 PRO with Global or Modular Trolley (Contd.,)

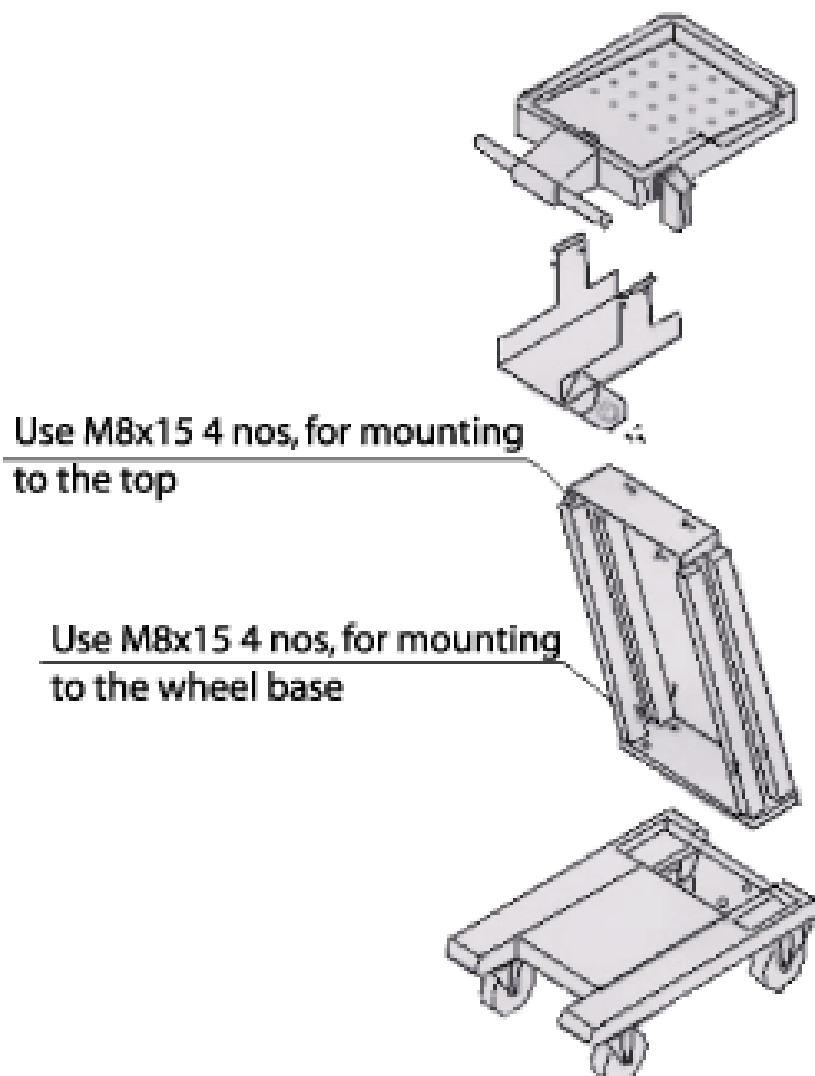

Figure 3-10 Modular Trolley Assembly

Installation of LOGIQ™ 100 PRO with Global or Modular Trolley (Contd.,)

- 3.) Remove two M4X10 screws from the base of LOGIQ™ 100 PRO and fix lock plate. Refer Figure 3-11
- 4.) Place the unit with lock plate fixed on Trolley, ensure that lock plate gets into the projection on the trolley. Refer Figure 3-11

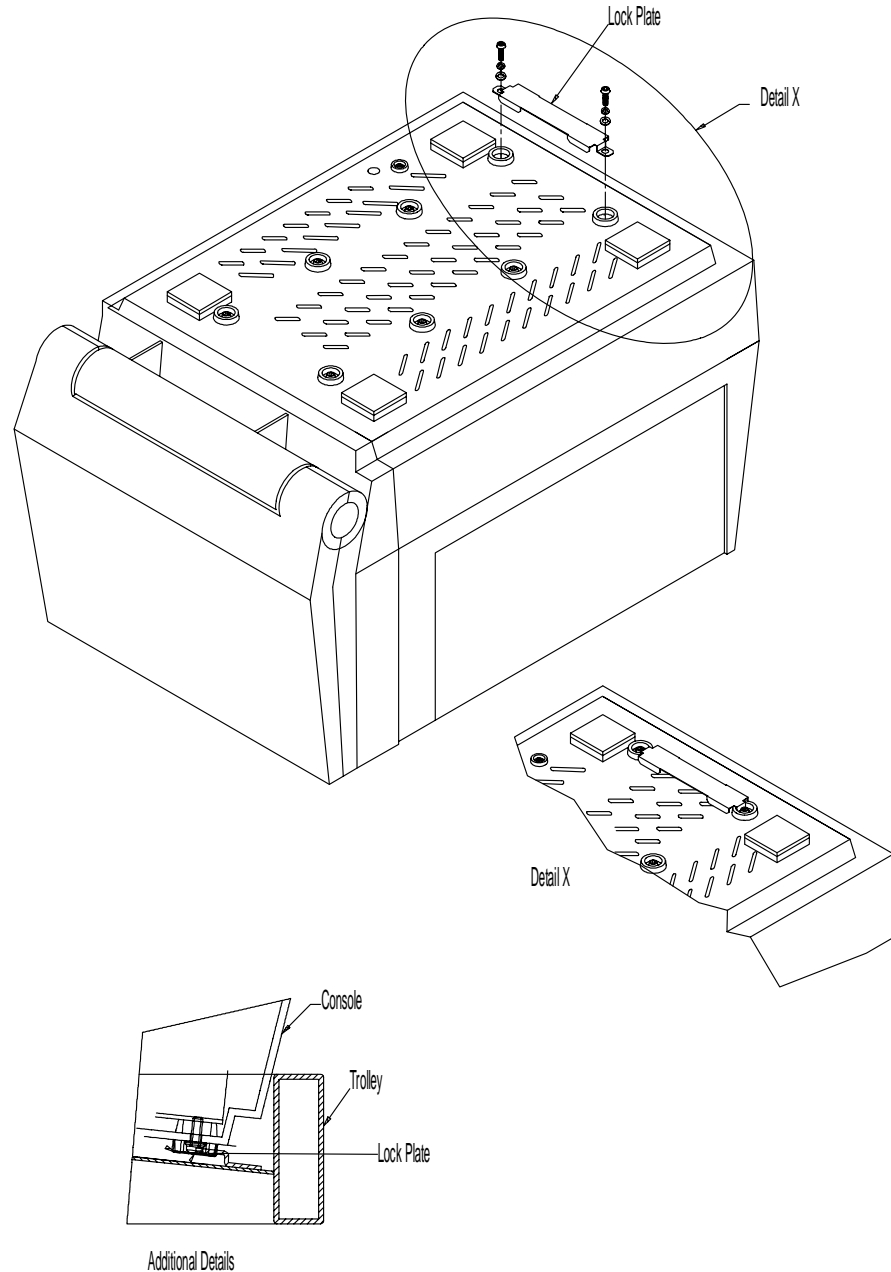

Figure 3-11 Installation of Trolley

Installation of LOGIQ™ 100 PRO with Global or Modular Trolley (Contd.,)

- 5.) Take the belt (provided in the kit) over the unit and lock it. Refer Figure 3-12
- 6.) Release the Keyboard by pressing the lock release and make it rest on the handle. Refer Figure 3-12
- 7.) Insert the VGP inside the Printer Tray and fix from the bottom using M3X12 screw. Refer Figure 3-12

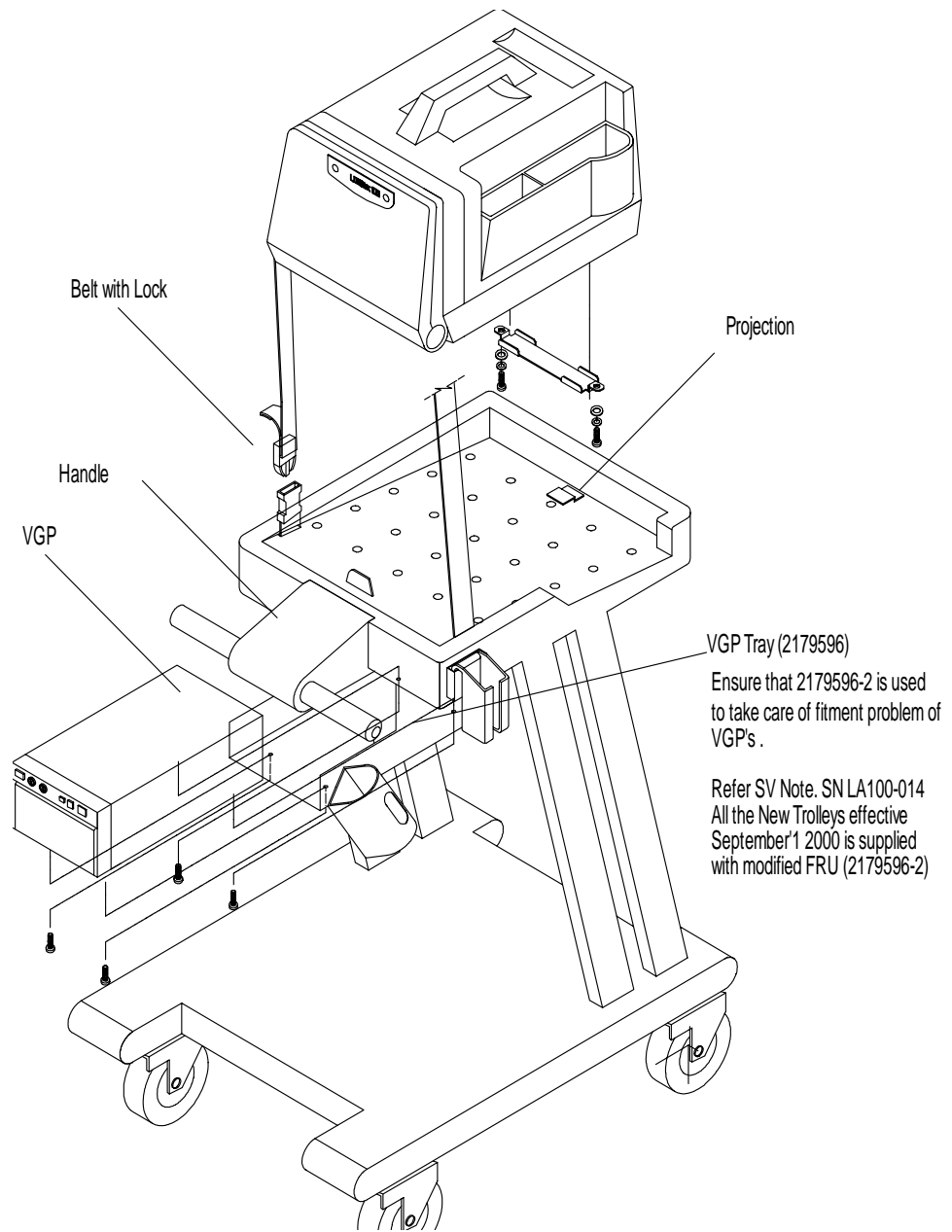

Figure 3-12 Installation of LOGIQ™ 100 PRO with the Trolley

Installation of LOGIQ™ 100 PRO with Global or Modular Trolley (Contd.,)

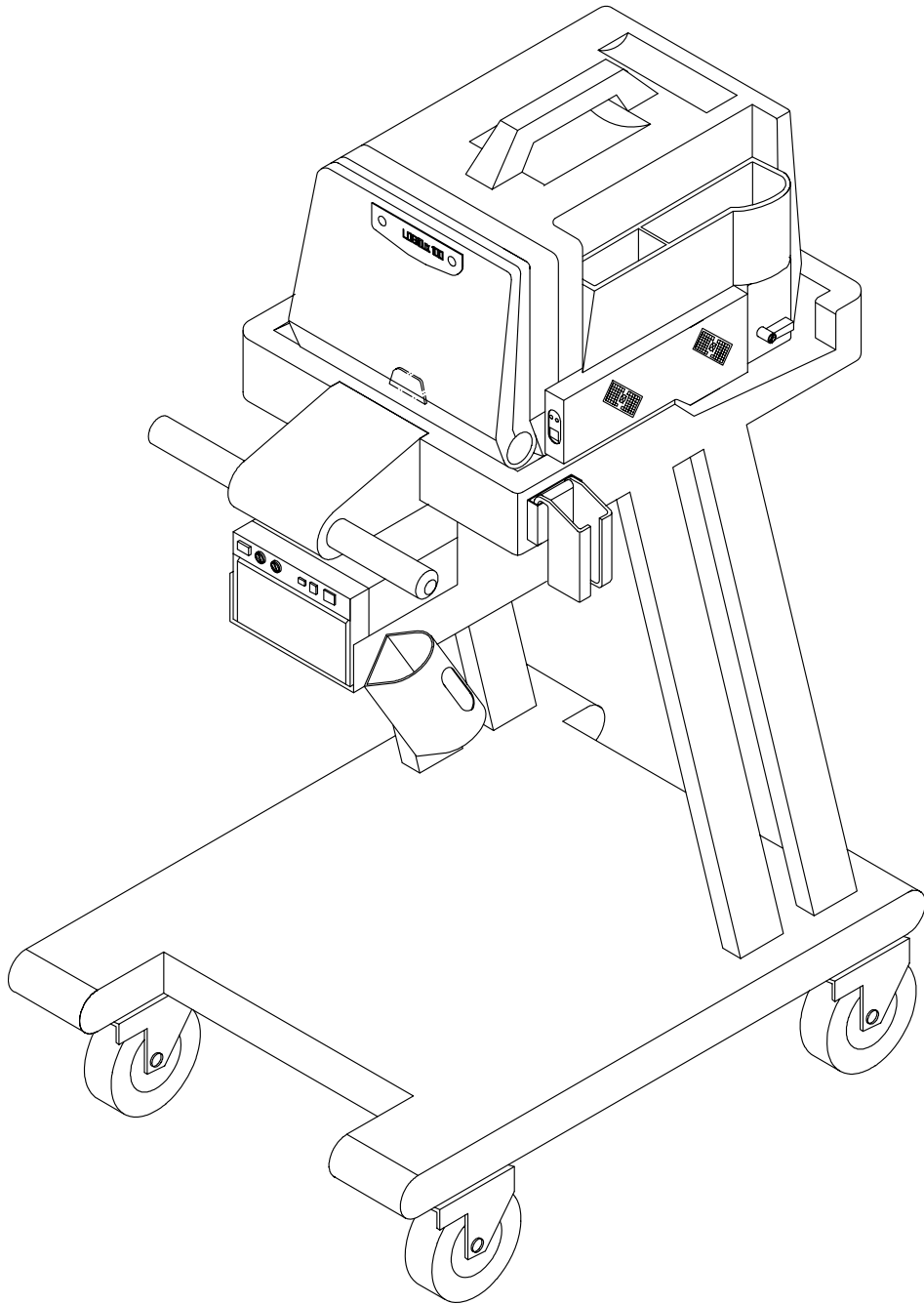

Figure 3-13 Installation of LOGIQ™ 100 PRO with Global or Modular Trolley

3-5-5 Adjustment of Monitor Brightness & Contrast

Turn ON the Machine and then adjust the monitor contrast and brightness. Monitor contrast and brightness should be adjusted according to the lighting in the room. For Monitor brightness and contrast adjustment refer to the appropriate section in the User Manual.

3-5-6 Adjustment of System Clock/Date, Hospital Name & OB Version

Press CTRL-S-1 ENTER, an 'Installation Setup window appears'. Set the system Clock/Date, Hospital Name and OB Version. These settings can be modified by using the CONTROL-S-1 key if required. Refer Section Control Keys of the User Manual for more details



CAUTION Functional checks in Chapter 4, to be carried out before handing over the system to the customer

Section 3-6 System Configuration

3-6-1 System Specifications

3-6-1-1 Physical Dimensions

The physical dimensions of the LOGIQ™ 100 PRO unit are summarized in Table 3-2.

Height	Width	Depth	Unit
28.9	30.24	42.06	cm

Table 3-3 Physical Dimensions of LOGIQ™ 100 PRO

3-6-1-2 Front View

WEIGHT : 9.00 Kgs

NOTE
LENGTH: mm(inches)
ABERRATION: "5%

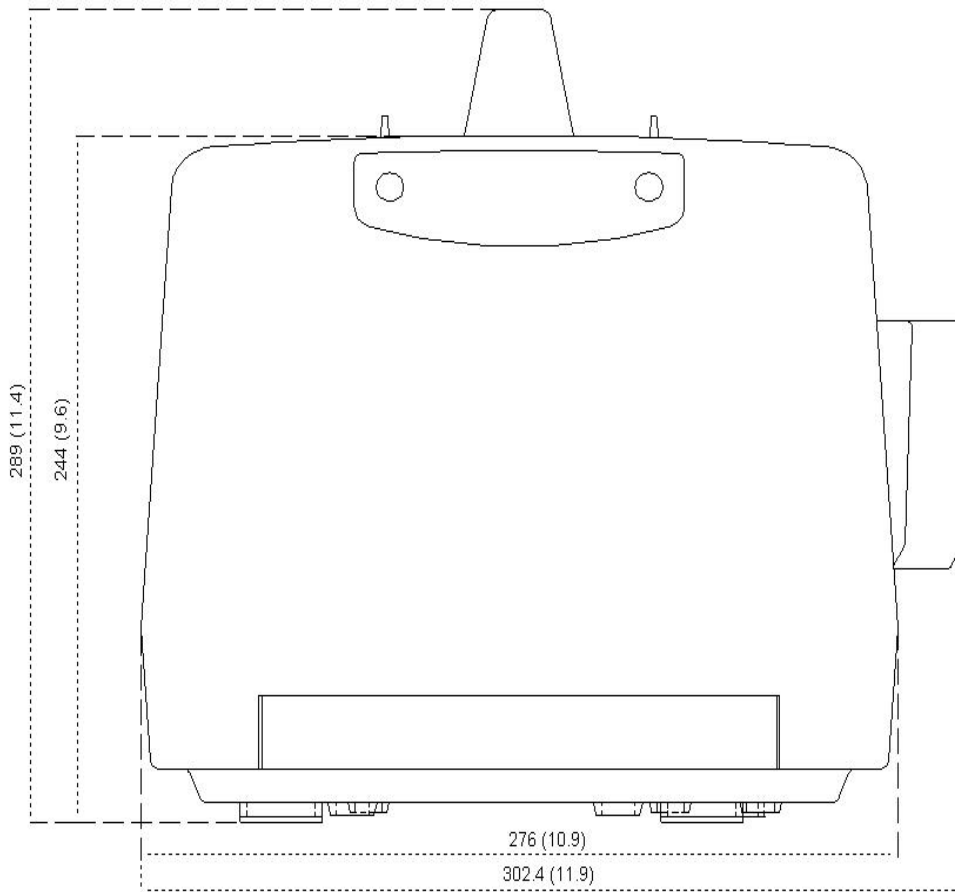

Figure 3-14 Front View

RELEASED UNDER E.O. 13526
SECTION 1.4

3-6-1-3 Side View (Keyboard Closed)

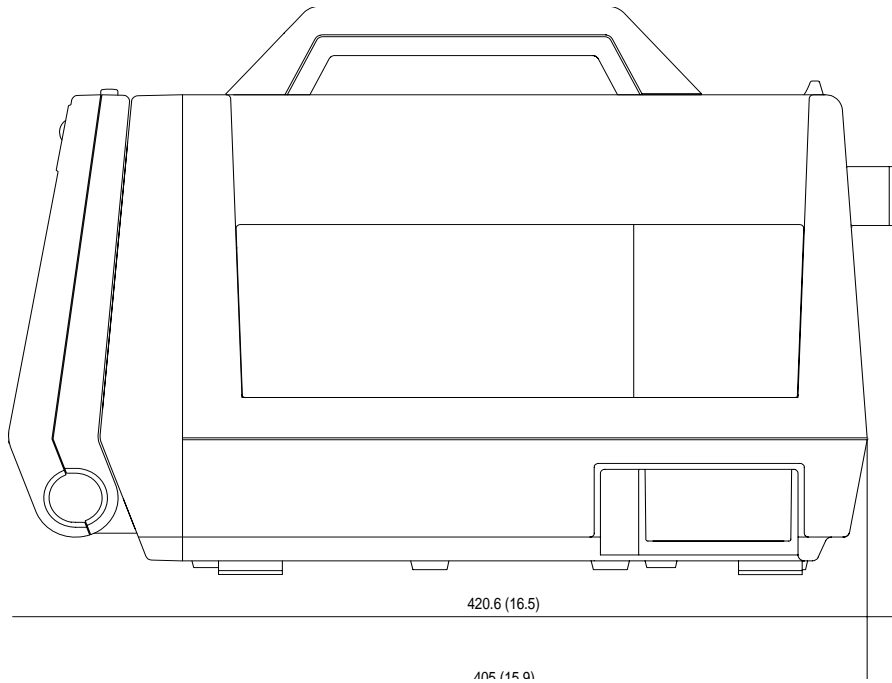

Figure 3-15 Side View (Keyboard Closed)

3-6-1-4 Side View (Keyboard Open)

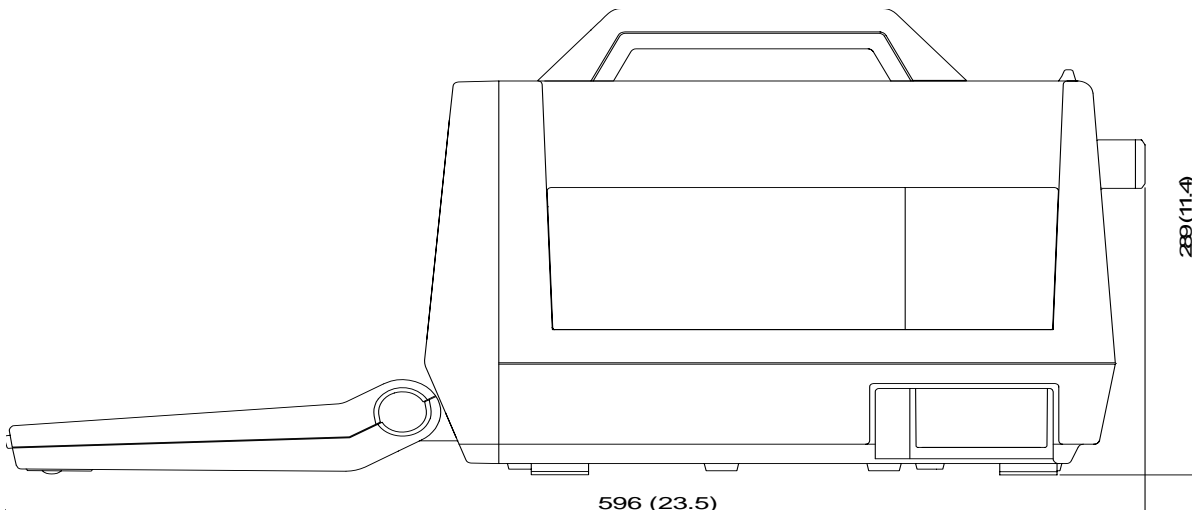
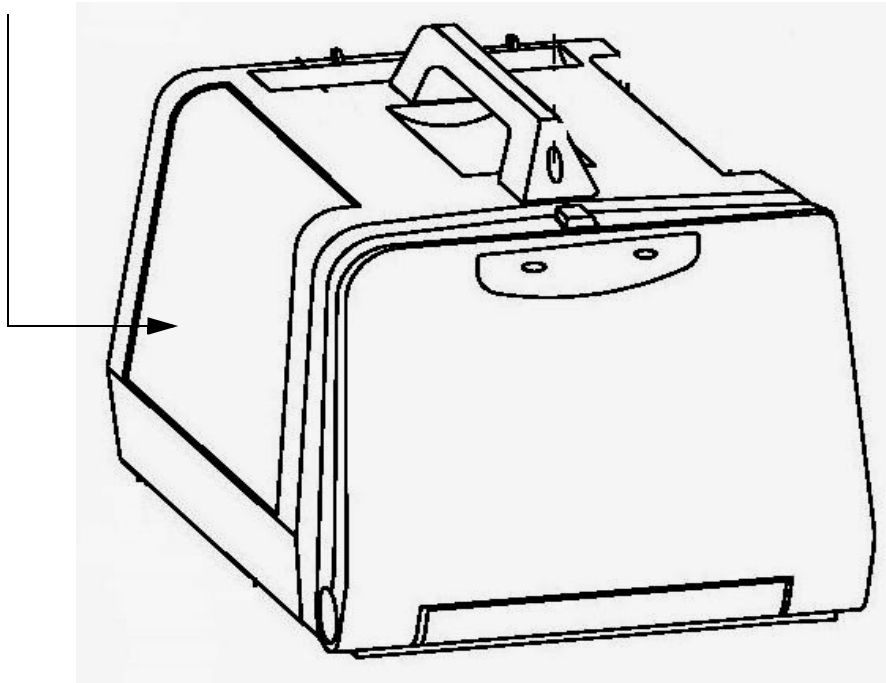

Figure 3-16 Side View (Keyboard Open)

SIDE VIEW



3-6-1-5 Weight without Peripherals

The Weight of LOGIQ™ 100 PRO without peripherals

Model	Weight [kg]
LOGIQ™ 100 PRO	9.00

Table 3-4 Weight of LOGIQ™ 100 PRO

3-6-2 Electrical Specifications

Electrical Specifications for LOGIQ™ 100 PRO.

GEMS HCAT NUMBER	Voltage	Tolerance s	Current	Frequency
H41072LA,H41072LB, H41072LC,H41072LD, H41072LE,H41072LF, H41072LS	100-230 VAC	±10%	0.9 -1.8 A Max.	50-60 Hz

Table 3-5 Electrical Specifications for LOGIQ™ 100 PRO

3-6-2-1 Power Supply

The Following Power Line requirement should be monitored one week before Installation. We recommend that a Drantex model 605-3 Power line Monitor with options 101 to be used

Table 3-6

Parameter	Limits	
Voltage Range	USA, JAPAN Europe	100-115VAC ± 10% (90-127VAC) 200-240VAC ± 10% (198-264VAC)
Power	USA, JAPAN Europe	MAX 145VA MAX 175VA
Line Frequency	All Applications	50/60Hz ± 2Hz
Power Transients	Less than 25% of nominal peak voltage for less than 1 millisecond for any type of transient, including line frequency, synchronous, asynchronous or periodic transients	
Decaying Oscillation	Less than 15% of Peak Voltage for less than 1 millisecond	

3-6-2-2 Facility Power Socket

A separate power outlet with a 5 amp circuit breaker for 120/220 VAC is recommended. The specific power receptacle used depends on the country's power line standards.

This receptacle should have International Electro technical Commission (IEC) approval, or equivalent

3-6-2-3 Storage & Operation Requirements

The LOGIQ™ 100 PRO is shipped in a single container excluding probes. Shipping weight is approximately 12 kgs. Table 3-7 Table provides a summary of temperature, atmospheric pressure, and humidity tolerances for shipping, installation and operation:

Table 3-7 Storage & Operation Requirements

Parameter	Storage	Operation
Temperature (Deg.C)	-10 to 60	10-40
Atmospheric Pressure (hPa)	700 to 1060	700 to 1060
Humidity (%) Non- Condensing	30 to 90	35 to 75

3-6-3 Optional Peripherals

LOGIQ™ 100 PRO peripherals and accessories can be properly connected using the connectors on the rear panel of the LOGIQ™ 100 PRO system.

External Optional Peripherals

- VCR (Sony SVO-9500MD)
- VGP (Sony UP-895MD/MDW and UPD-897MDW)
- Printing through Laser Jet Printer with HP LaserJet 1020 Plus.
- Images can be transferred to memory stick from the image archive.

Printing should not be done while live scanning patients. Also, the Printer cable should not be attached to the LOGIQ™ 100 PRO during the scan.

For Europe Only: All devices connected to the LOGIQ™ 100 PRO must be CE Marked.

Located on the panel are video input & output connectors, footswitch connector, shutter connector, power connector & control connections for Video Graphic Printer and USB Port for the LOGIQ™ 100 PRO.

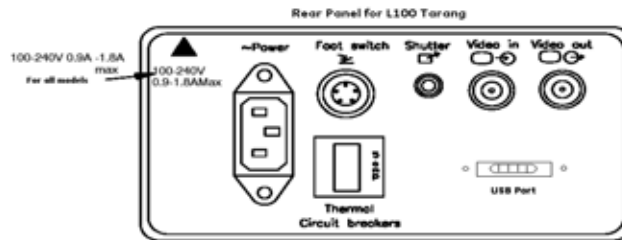

Figure 3-17 Optional Peripherals

The Thumb Drive/Memory Stick (Model TS512MJF150), HP Laser Jet printer(HP1020), Sony VGP Printer(Model UP-D897MD/ UP-897MD) can be connected through the USB slot provided in the rear panel.

3-6-4 Peripherals Connections and Installation

3.6.4.1 FootSwitch Connection

The footswitch which is the remote **FREEZE** device is connected to the rear panel of the system. this extra **FREEZE** switch is provided to enhance flexibility to freeze images when the system is not within reach of the user.



Figure 3-18 Foot switch connection to rear panel

Pin Assignment of Foot Switch Connector

Pin No.	Signal
1	Foot Switch
2	GND
3	GND
4	GND
5	GND

Figure 3-19 Foot Switch Connector (Round 5-pin connector)

Installation of the Foot switch:

- 1.) Switch ON the LOGIQ™ 100 PRO unit.
- 2.) Connect the footswitch cable to the Footswitch slot provided in the rear panel.
- 3.) Press foot switch to check its functionality.
- 4.) By pressing the foot switch pedal the image in the screen should freeze.

3.6.4.2 Video Graphic Printer (VGP)

Connect the Video Graphic printer (with USB A to USB B cable) to the USB port located on the rear panel of the system.

Model: (Sony UP-D897MD or UP-897MD)



Figure 3-20 Connection of USB cable to Printer

Installation of VGP:

- 1.) Place the SONY Digital Printer on the fixture.
- 2.) Fix one end of power cable and USB cable to the printer.
- 3.) Fix the other end of USB cable to the USB slot provided in the rear panel and power cable to the Power socket.
- 4.) Switch ON the LOGIQ™ 100 PRO and VGP printer.
- 5.) Press the Recall button on the keyboard to view the stored images.
- 6.) Press Record button on the keyboard and check if the selected image matches with the VGP print out.

3.6.4.3 Pin Assignment of Mini Jack controlling VGP

Pin No.	Signal	
1	Shutter	
2	Signal GND	

Figure 3-21 Shutter Connector

3.6.4.4 Video Cassette Recorder

Connect the VCR Sony SVO-9500MD (H4120SR) for NTSC and Sony SVO 9500MDP(E11801AA) for PAL System to the Video IN socket in the rear panel. Press the "EXT. VIDEO" button on the keyboard to enable an external video signal on the system monitor. SVHS tape should be used for recording.

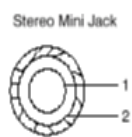

Figure 3-22 VCR connection to Rear panel

Installation of VCR:

- 1.) Connect the SONY VCR
- 2.) Switch on the VCR and the LOGIQ™ 100 PRO unit.
- 3.) Press the Record key to record the image.
- 4.) Press the External video key on the keyboard to enable external video(i.e VCR Playback)to be viewed on the LOGIQ™ 100 PRO system monitor.

3.6.4.5 Laser jet printer

Connect the HP1020 Laser jet printer to the USB port provided in the rear panel of the system.This enables you to take paper printout of the images and report pages.The LOGIQ™ 100 PRO supports printing in A4 size papers in the HP laser Jet 1020Series with standard USB cable.



Figure 3-23 Printer connection to Rear panel

Installation of Laser Jet Printer:

- 1.) Switch ON on the LOGIQ™ 100 PRO unit.
- 2.) Connect the USB cable from the printer to the USB port provided in the rear panel of LOGIQ™ 100 PRO unit.
- 3.) To Print images/Report pages, Press Shift+ Record.

3.6.4.6 USB MEMORY STICK

This module serves as an interface which enables users to transfer images from LOGIQ™ 100 PRO to USB memory stick. LOGIQ™ 100 PRO in JPEG format. This can be further uploaded to any PC having windows operating system and USB port support.



Figure 3-24 USB Memory Stick connection to Rear Panel

Installation of USB Memory Stick:

- 1.) Connect the USB Memory stick to the USB port provided in the rear panel of LOGIQ™ 100 PRO unit.
- 2.) Press the recall key. From the main menu Press 4 to enter the multiple selection menu.
- 3.) To transfer the images to a Memory stick move the trackball to the images that you want to transfer and press 3. To transfer all images available in the archive press 2 to select images and 3 to transfer images to Memory stick.

Please ensure that the USB Memory stick has to be connected before attempting to transfer images to USB Memory stick. If USB is not connected to the LOGIQ™ 100 PRO system, the system will prompt "USB not connected".

Do not remove the USB Memory stick when the image is getting transferred.

Note : USB hard disk drive may/may not be recognized by the system.

3.6.4.7 Available probes for LOGIQ™ 100 PRO

See in Specifications in the LOGIQ™ 100 PRO User manual for probes and intended use.

Probe Type	Part No.	Catalog No.	Freq in MHz
C36	2268634	H41252CF	3.5
C55	2107925	H45252CE	5.0
E72	2274908	H41252ME	6.5
L76	2274906	H41252HP	7.5
C31	2175994	H45252CS	3.5
*CZB	2152422	H45202CZ	6.5
*LB	P9601AQ	H46022LB	3.5

Table 3-8 Available Probes

* This Probes are available only for LOGIQ™ 100 PRO with LOGIQ 200 Probe Adapter.

Use only approved probes, peripherals or accessories.

3-6-5 Video Specification

Video specifications may be needed to be able to connect laser cameras to the LOGIQ™ 100 PRO.

General			
SL	Parameter	NTSC	PAL
1	Total Number of Horizontal Lines	525[Frame]	625[Frame]
2	Vertical Field Frequency	60[Hz]	50[Hz]
3	Horizontal Scanning Frequency	15.734[kHz]	15.625[KHz]
4	Vertical Scanning Method	Interlaced	Interlaced
5	Sync Input	Composite	Composite
6	Pixel Clock	12.272715[MHz]	12.25[MHz]
7	Display width and Height [pixel * line]	608 X 464	608 X 472
Horizontal Timing & Video Amplitude			
SL	Parameter	NTSC	PAL
1	Total H-Line Time	63.556[micro sec.]	64.00[micro sec.]
2	H-Sync Pulse Width	4.725[micro sec.]	4.68[micro sec.]
3	Back Porch	4.725[micro sec.]	4.68[micro sec.]
4	Total Active H-line time	52.64[micro sec.]	52.07[micro sec.]
5	Front Porch	1.46[micro sec.]	1.49[micro sec.]
6	Video Amplitude (back porch to peak)	0.7Vpp	0.7Vpp
7	Sync Amplitude (back porch to peak)	0.3Vpp	0.3Vpp
Vertical Timing			
SL	Parameter	NTSC	PAL
1	Total V-Line Time	262.5[H]	312.5[H]
2	V-Sync Pulse Width	1st Field 3[lines]	1st Field 2.5[lines]
		2nd Field 3[lines]	2nd Field 2.5[lines]
3	V-front porch	1st Field 7.5[lines]	1st Field 6.25[lines]
		2nd Field 7.5[lines]	2nd Field 6.25[lines]
4	V-Blanking	1st Filed 30.5[lines]	1st Filed 32[lines]
		2nd Field 30.5[lines]	2nd Field 32[lines]

Section 3-7 Paperwork

Note: During and after installation, the documentation (i.e. User Manuals, Installation Manuals...) for the peripheral units must be kept as part of the original system documentation. This will ensure that all relevant safety and user informations are available during the operation and service of the complete system.

3-7-1 User Manual(s)

Check that the correct User Manual(s), per software (sw) revision, for the system is included.

3-7-2 Product Locator Card

Fill out proper customer information on the Product Locator Installation Card. Refer to Illustration below. Mail this Installation Card "Product Locator" to the address corresponding to your pole.

Note: The Product Locator Installation Card shown in Figure 3-25 may not be same as the Product Locator card actually provided.

Mailing Address: GE Medical Systems
 Product Locator File
 P.O. Box 414
 Milwaukee, WI
 53201-0414

DESCRIPTION	FDA	MODEL	REV	SERIAL NO.
-------------	-----	-------	-----	------------

PREPARE FOR ORDERS THAT DO NOT HAVE A LOCATOR INSTALLATION REPORT

DIS.-COUNTRY/ROOM	EMPLOYEE NO.
-------------------	--------------

SYSTEM ID NUMBER

INSTALLATION

CUSTOMER NO.

DESTINATION NAME AND ADDRESS

ZIP CODE

Figure 3-25 Product Locator Card

RELEASED UNDER
SECTION 552

Chapter 4 Functional Checks

Section 4-1 Overview

4-1-1 Purpose of Chapter 4

This chapter provides procedures for quickly checking major functions of the LOGIQ™ 100 PRO scanner, diagnostics by using the built-in service software, and power supply adjustments. For remaining functional checks please refer to the LOGIQ™ 100 PRO Operator's Manual.

CONTENTS IN CHAPTER 4

Section	Description	Page Number
4-1	Overview	4-1
4-2	General Procedures	4-2
4-3	Functional Check Procedures	4-4
4-4	Diagnostics	4-9
4-5	Software Configuration Checks	4-10
4-6	Peripheral Checks	4-10
4-7	Patient contact tools	4-11

Table 4-1 Contents in chapter 4

Section 4-2 General Procedures

4-2-1 Power On/Boot Up

Note: After turning off the system, wait at least ten seconds before turning it on again. The system may not be able to boot if power is recycled too quickly.



CAUTION SYSTEM REQUIRES ALL COVERS

Operate this unit only when all board covers and frame panels are securely in place. The covers are required for safe operation, good system performance and cooling purposes.

4-2-1-1 System Boot-UP/Shutdown

Purpose: This is a description on how to Shut Down/Power-UP the system.

4-2-1-2 Lockout/Tagout Requirements (For USA/Europe)

Follow OSHA Lockout/Tagout requirements by ensuring you are in total control of the plug.

4-2-1-3 Power Up

- 1.) Connect the Power Cable at the rear of the System.
- 2.) Connect the Power cable to an appropriate mains power outlet .

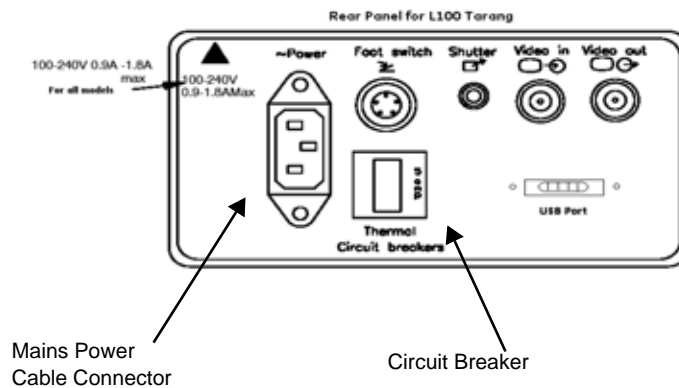

Figure 4-1 Mains Circuit Breaker and Mains Power Cable

4-2-1-4 Front Panel ON/OFF

Press the Front Panel ON/OFF key once. to Switch ON/OFF

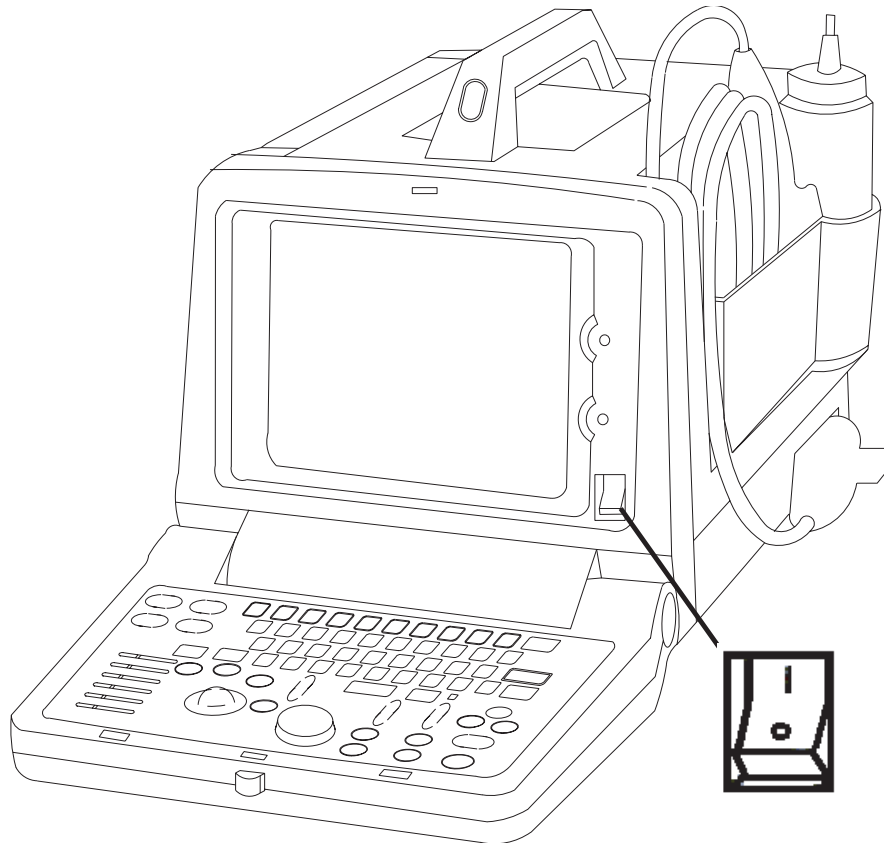

Figure 4-2 ON/OFF key on Front Panel

When power is applied to the Scanner, Power is distributed to the Fan, Control panel, Monitor, Internal and External I/O's, Boards & Peripherals. Back End Processor starts and its software code is distributed to initiate the scanner.

Power Up Display Comes Up. Refer figure 4-3.

4-2-1-5 Power Shutdown

- 1.) Switch OFF the ON/OFF at the Front of the system.
- 2.) Disconnect the Mains Power Cable if needed.

Section 4-3 Functional Check Procedures

To perform these tests, you will need a convex or a linear probe. These procedures should be performed during installation. These procedures are also used as basic checks to use when service of the system is required.

Turn "ON" the LOGIQ™ 100 PRO system. The 2 LEDs, External Video and Freeze blink and go off. The Monitor displays the following. Refer figure 4-3 for details.

- 1.) B-Mode Image appears
- 2.) Gray Scale Display
- 3.) Horizontal Scale Marker
- 4.) Vertical Scale Marker
- 5.) Hospital Name (If previously entered)
- 6.) Date
- 7.) Time
- 8.) Probe Type
- 9.) Focus Marker on vertical scale
- 10.) Depth (150mm)*
- 11.) Gain (G54) *
- 12.) Dynamic Range (D54) *
- 13.) Frequency **.

* Points 10-12 form a continuous code in the lower left hand corner of the monitor and they are factory default values.

** Only for C36 Probe.

4-3-1 Power Up Monitor Display (Convex Probe)

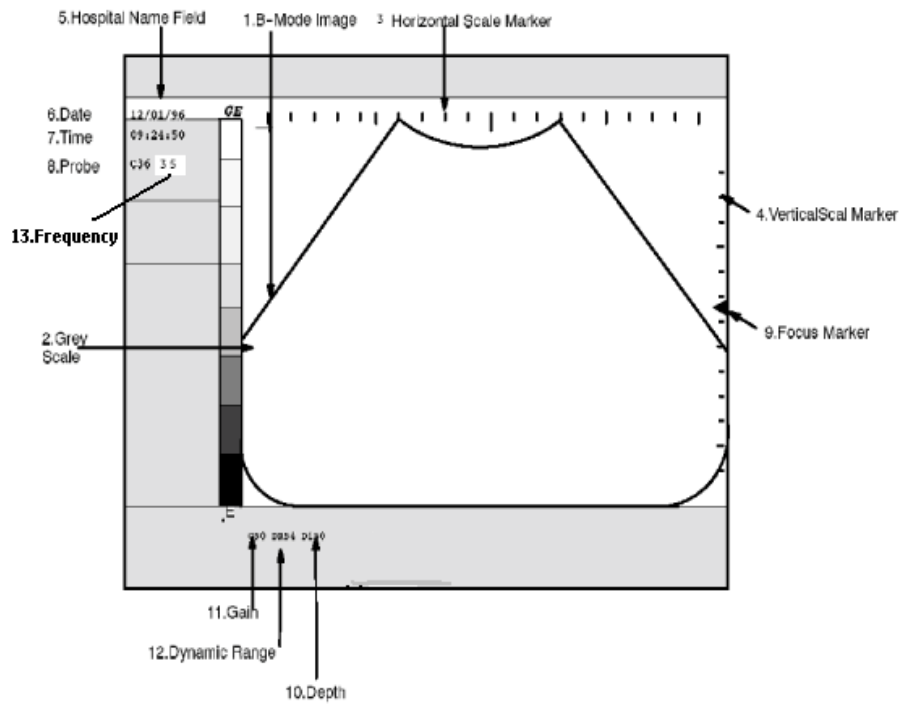

Figure 4-3 Power Up Monitor Display (Convex Probe)

4-3-2 Basic Controls

Table 4-2 describes basic controls which helps in checking the LOGIQ™ 100 PRO during installation.

Connect the sector or convex transducer to connector on the right side of the base.

TASK	Expected Result
Turn `ON' Power Switch	B-Mode screen as in figure 4-3 should appear
Press New Patient Key	A pop-up window appears. Enter Patient Name/ID. It presets the system
Press ID/Name	A pop-up window appears. Enter Patient Name/ID. It does not preset the system.
Press Dyn Range Up/Down	Image grows softer and harder depending on position.
Rotate Gain Knob	Image grows lighter and darker with rotation.
Press Reverse	The image will be displayed Left/Right
Press Reverse a second time	The image will be displayed Right/Left.
Press SHIFT + Reverse	The image will be displayed Top/Bottom
Press SHIFT+ Reverse a second time	The image will be displayed Bottom/Top
Press M key	B/M Mode with M-line cursor appears. (Use trackball to move the M-line cursor). Refer Figure 4-4
Roll Trackball	The M-Line cursor should follow the trackball movement and the real-time image varies on the M-Mode display.
Press M key a second time	Only M-Mode image appears on the screen. Press B Mode Key to exit M-Mode.
Press Freeze key	The image will freeze.
Press ATO	ATO, Automatic Tissue Optimization, optimizes the image based upon a specified Region Of Interest (ROI) or anatomy within the display. ATO Gray scale map is available only in B-Mode.
Press Freeze and Zoom	Zoom is used to magnify an image. The magnification factor for zoom is fixed at 2.0. The system adjusts all imaging parameters accordingly.
Roll Trackball	To select the ROI for Zoom Zoom feature is available in the freeze mode only.

Table 4-2 Basic Controls

TASK	Expected Result
<p>CINE (Press Freeze and Rotate B/M Gain/ Cine Scroll)</p> <p>Cine Menu:</p> <p>Press 1 (Start Frame)</p> <p>Press 2 (End Frame)</p> <p>Press 3 (Cine Loop)</p> <p>Press 4 (Cine Gauge)</p>	<p>The Cine Gauge, menu and the Cine frame number appears at the bottom of the display. Rotate the Cine Scroll dial to move through the images in Cine Memory. Cine frame number is displayed on the left side of the screen. Move the Cursor by rotating the Cine Scroll dial to the frame you want and press 1 again to select the Start frame. Move the Cursor by rotating the Cine Scroll dial to the frame you want and press 2 again to select the End frame. Enters into Cine loop within the selected Start & End frames. To toggle between the Cine Gauge display</p>
<p>Flash Memory (Image storage)</p> <p>Freeze the image Press Store</p> <p>Press Recall</p>	<p>Comment column appears at the bottom of the display. Enter the comment in that and press Store again to Store the image.</p> <p>Image Archive screen appears with option menu at the bottom. Select the image using the trackball (Use Dynamic Range to page up/down in the Image Archive screen). Press 1 to View the selected image. Press 2 to Clear the selected image. Press 3 to Clear All the stored images. Press 4 to Sort the images by name or date. To Exit Image Archive, press Clear. Unfreeze to exit from the freezed image.</p>
<p>TGC</p>	<p>The TGC is used to adjust the Gain at a specific depth. Slide the control to the right or left to increase or decrease gain.</p>

Table 4-2 Basic Controls

Refer User Manual for the Remaining Operations

Basic Controls (Continued)

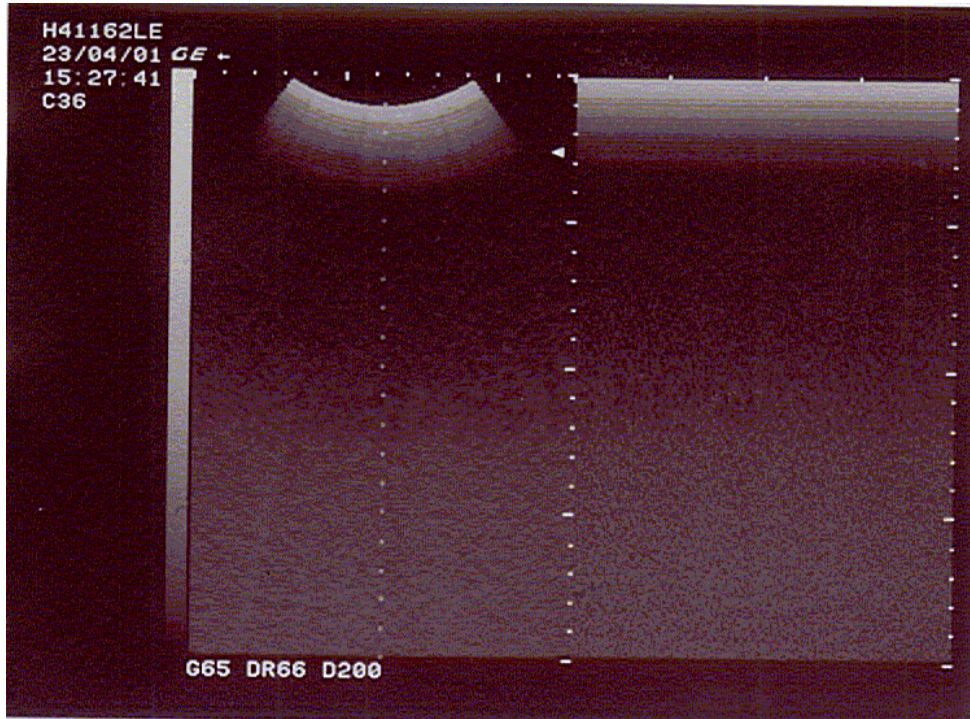

Figure 4-4 B/M Mode Display

RELEASSED UNDER SECTION 504

Section 4-4 Diagnostics

The LOGIQ™ 100 PRO System service diagnostics comprises of:

- 1.) Self test or power on diagnostics
- 2.) Service diagnostic tools

The self test or power on diagnostics are run every time the system is booted. The service diagnostic tools include test procedures for testing the system at PCB level as well as block level. The diagnostic tools provides a pop-up menu to enable selection of various tests to test various blocks on the system.

4-4-1 Power On Diagnostics

The power on diagnostics or self tests are run every time the system is booted. This self tests include testing the validity of the system software through EPROM checksum test and testing the system RAM. It checks whether the keyboard and the trackball are properly interfaced to the system. It also initiates the self test of analog subsystem. The two LED's and the beeper are used to indicate error conditions.

Note: Power on Diagnostics works only when the system is in application (imaging) mode and not while on service diagnostics.

4-4-2 Service Diagnostics

For More Details on Service Diagnostic refer Chapter 7.

PCB	LED Location	Function
FEB	LED - Location on FEB D65	This LED indicates the scan lines,the DSP is scanning.The LED glows when the cursor is moved in the B/M mode
FEB	LED - Location on FEB D66	This LED indicates the probe connect signal is good.This indicates the FEB is Good
FEB	LED - Location on FEB D67	This LED indicates the B mode signal is given to the display.The intensity of this LED is more during B mode.
FEB	LED - Location on FEB D68	This LED indicates the M mode signal is given to the display.This LED glows during M and B/M mode,the intensity of this LED is less during B/M mode
DAVINCI	LED - Location on Davinci CPU D12	This LED is ON during Acoustic Frame measurement switching.This also indicates the communication between the DSP and the Davinci CPU FPGA
DAVINCI	LED - Location on Davinci CPU D11	This LED indicates the Video Sync is happening.This indicates the video frame output from the Davinci CPU to the monitor is ok.
DAVINCI	LED - Location on Davinci CPU D10	This LED indicates the KEY press on the keyboard.It glows intermittantly when there is a key pressed.
DAVINCI	LED - Location on Davinci CPU D09	This LED indicates the USB connection to the Rearpanel.When a USB device or Pen drive is connected, the LED glows to indicate it is to the Davinci CPU.(USB output of the Davinci is Good)

Section 4-5 Software Configuration Checks

Step	Check	Expected Result(s)	If Not Remedy
1.	Check Date and Time setting	Date and Time are correct	Adjust the Date and Time setting
2.	Check that Location (Hospital Name) is correct	Location Name is correct	Re-enter the correct Location Name

Table 4-3 Software Configuration Checks

Section 4-6 Peripheral Checks

Check that peripherals work as described below..

Step	Check	Expected Result(s)	If Not Remedy
1.	Press Freeze Key	To stop image acquisition.	
2.	Press RECORD Key on the Control panel	The image displayed on the screen is printed on B&W Video Graphic Printer.	
3.	Press SHIFT + RECORD Key on the Control Panel.	To image or report page displayed on the screen is printed on the Laser Jet Printer connected to the USB Port of the System.	
4.	Press SHIFT + RECORD Key on the Control Panel.	To print the displayed image on the screen to the USB B&W Video Graphic Printer.	
5.	Press EXTERNAL VIDEO Key on the Control Panel	Enables an External Video Input Playback on the LOGIQ™ 100 PRO monitor. Press once again to return to the scan mode	

Table 4-4 Peripheral checks

Section 4-7 Patient contact tools

4-7-1 Probe/Connectors Check

Take the probes and check them as described below.:

Step	Check	Expected Result(s)	If Not Remedy
1.	To test each delivered Probe, Connect it to the System	It will display the probe name on the screen	
2.	Hold the probe connector horizontally with the cable pointing Sideways. Turn the connector locking handle to the Vertical position. Align the connector with the probe port and carefully push into place. Rotate the locking handle to the full Horizontal position to lock in place. Position the probe cable so that it is not resting on the floor CAUTION: Do not allow the probe head to hang freely. Impact to the probe head may result in irreparable damage.	To connect a probe:	
3.	Rotate the lock handle counter-clockwise to the Vertical position to unlock the connector. Remove the connector from the port Ensure that the probe head is clean before placing the probe in its storage case.	To disconnect probes: <i>The probes that are not connected to the unit should be stored in their storage case.</i>	
4.	To test the Two Probe Adapter, Connect it to the System	To connect to the probe port	
5.	Hold the Two Probe Port connector horizontally Turn the connector locking handle to the Vertical position. Align the connector with the probe port and carefully push into place. Rotate the locking handle to the full Horizontal position to lock in place.	To connect a probe:	
6.	Two Probes can be Switched by pressing the Key on the Two Probe Port	The LED toggles to indicate the probe change & a click is also heard to indicate change over The system initializes the new probe & the image from the newly selected probe is displayed in the B-Mode	
7.	Presetting Parameters to a Probe, Select the desired probe & adjust the desired parameters Press CTRL + W + Enter	The Parameters selected will be set as Default Values	
8.	To test the LOGIQ PROBE ADAPTER, connect it to the system	Connect the Adapter to the Port	

Table 4-5 Probe and connectors check

Step	Check	Expected Result(s)	If Not Remedy
9.	Hold the probe connector horizontally with the cable pointing Sideways. Turn the connector locking handle to the Vertical position. Align the connector with the probe port and carefully push into place. Rotate the locking handle to the full Horizontal position to lock in place. Position the probe cable so that it is not resting on the floor CAUTION: Do not allow the probe head to hang freely. Impact to the probe head may result in irreparable damage.	It will display the Probe name on the Screen	

Table 4-5 Probe and connectors check

 **WARNING** Probes can be connected at any time, whether the unit is on or off

 **WARNING** *Do NOT touch the patient and any of the connectors on the ultrasound unit simultaneously, including ultrasound probe connectors.*

RELEASED UNDER DISCOVERY
 SECTION 104

Section 5-1 Overview

5-1-1 Purpose of Chapter 5

This chapter explains LOGIQ™ 100 PRO's system concepts, component arrangement, and subsystem function. It also describes the Power Distribution System (PDS) and probes.

CONTENTS IN CHAPTER 5

Section	Description	Page Number
5-1	Overview	5-1
5-2	General Information	5-2
5-3	Block Diagram	5-3
5-4	Wiring Diagrams	5-8
5-5	Functional Subsystems	5-12
5-6	Video Specifications	5-14
5-7	Rear Panel Signal List	5-14

Table 4-6 Contents in Chapter 5

Section 5-2 General Information

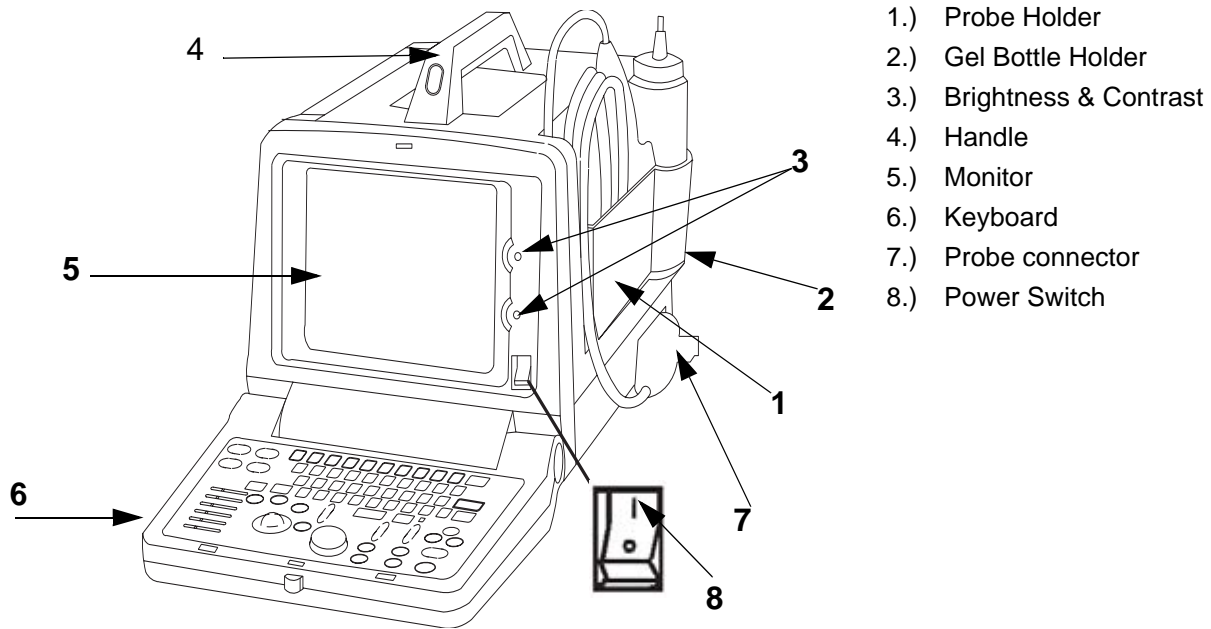

Figure 4-5 LOGIQ™ 100 PRO Major Components

- LOGIQ™ 100 PRO is a portable ultrasound imaging scanner. It also has provisions for analog input sources like The system can be used for:
 - B-Mode Black and White imaging
 - M-Mode Black and White imaging
 - Combinations of the above
- LOGIQ™ 100 PRO is a digital beam forming system and can handle up to 16 channel,64 element by use of multiplexing.
- Signal flow from the Probe Connector to the Front End, then to the Mid Processors and Da Vinci CPU and finally to the monitor and peripherals.
- System configuration is stored on EPROM and all necessary software is loaded when powered up.

Section 5-3 Block Diagram

Block Diagram

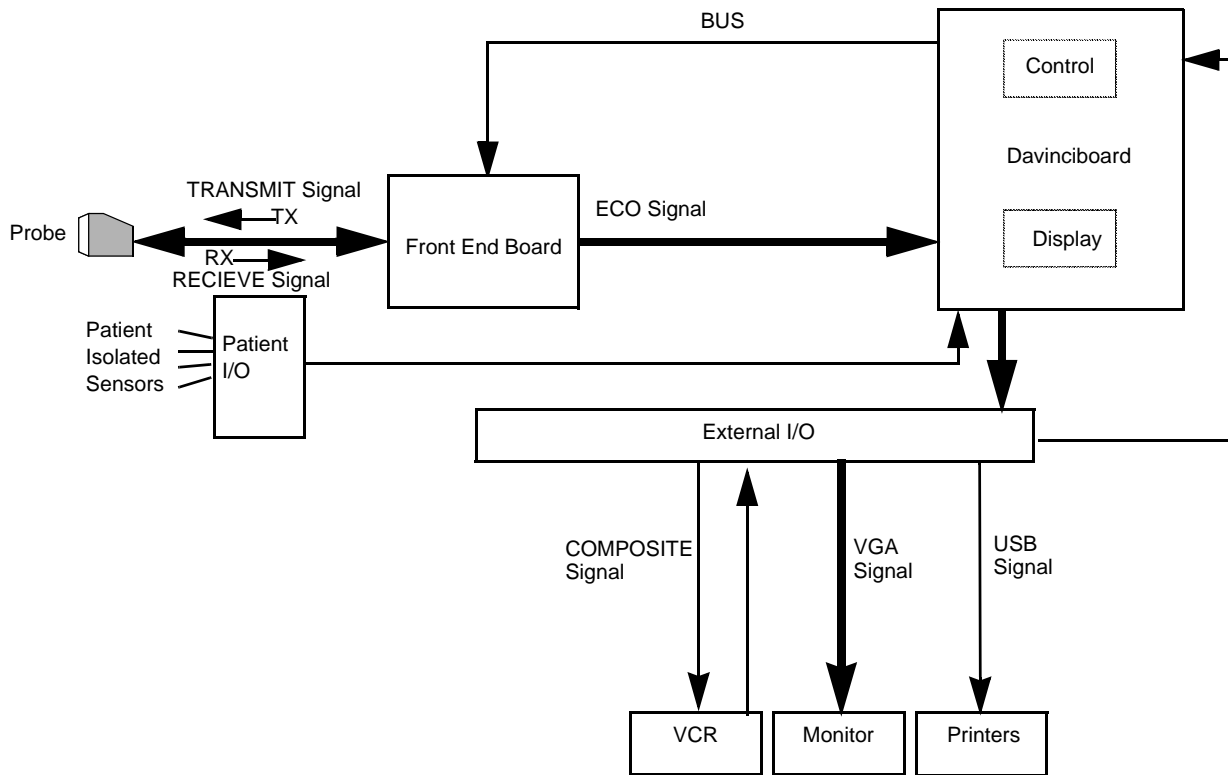

Figure 4-6 Block Diagram, LOGIQ™ 100 PRO (General)
 Dip Switch settings in DAVINCI Board

DIP 1	DIP 2	MODE
1	0	Normal mode
0	1	Service mode

Table 4-7

DIP 3	MODE
0	NTSC
1	PAL

Table 4-8 NTSC & PAL settings



FEB Block Diagram.

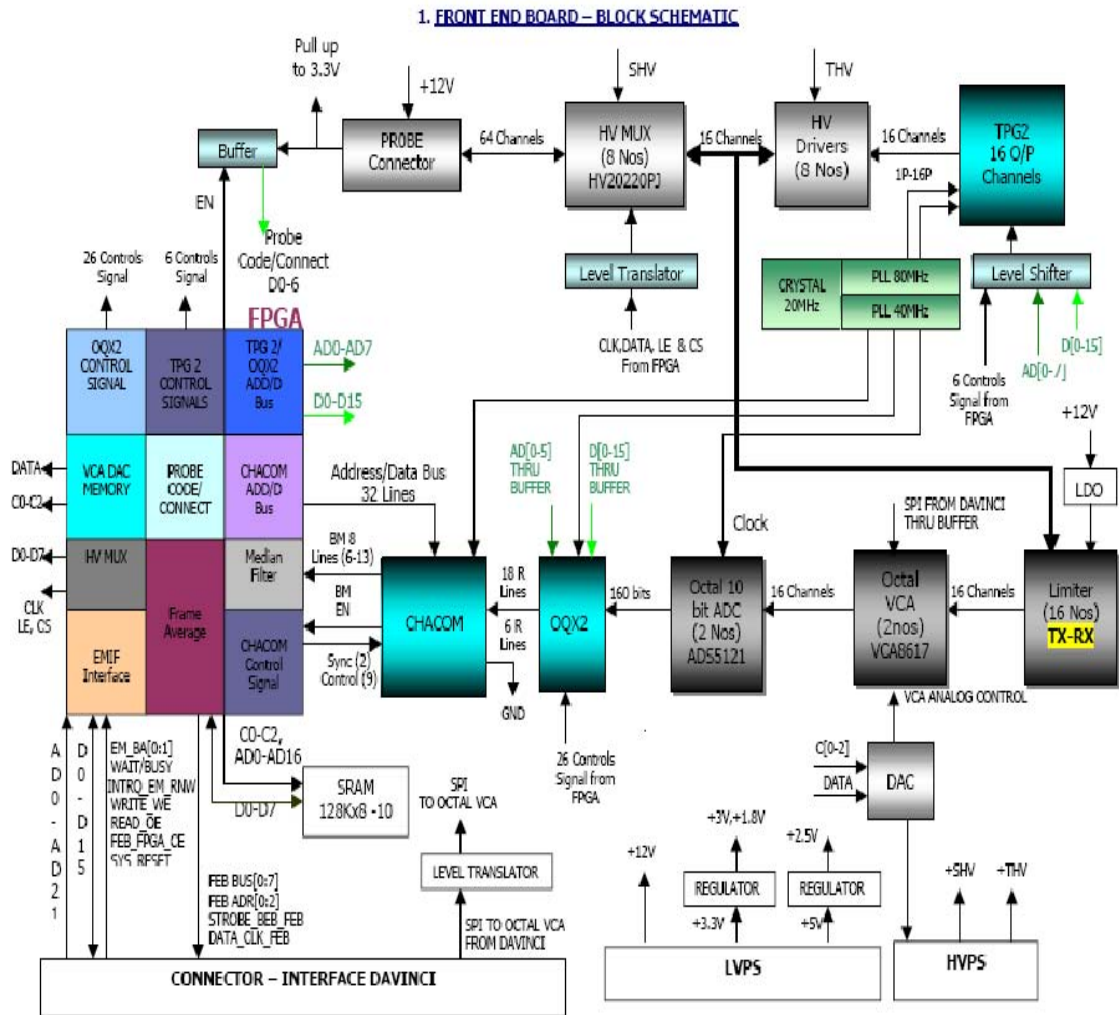

Figure 4-7 Block Diagram of FEB LOGIQ™ 100 PRO

UNCLASSIFIED//FOR OFFICIAL USE ONLY
 RELEASED UNDER E.O. 13526

5-3-1 DAVINCI Block Diagram.

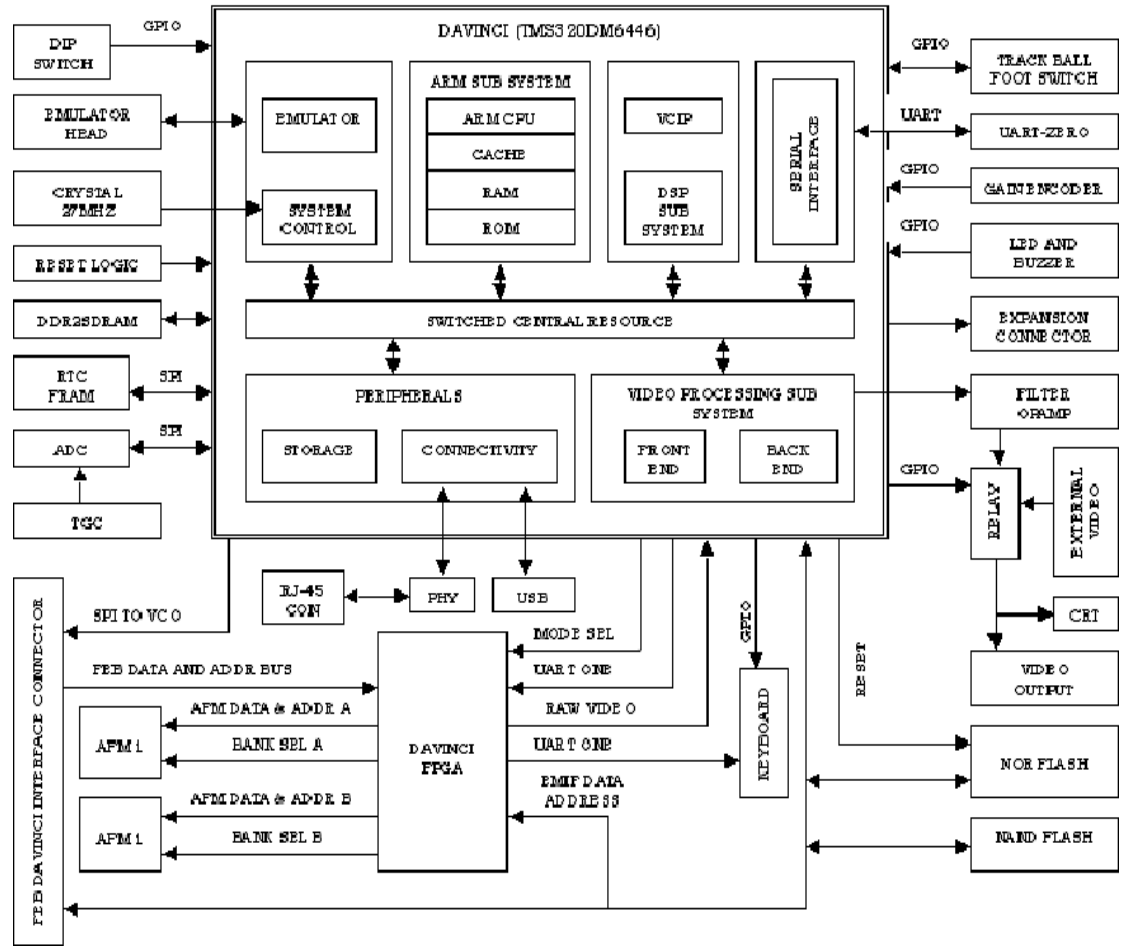
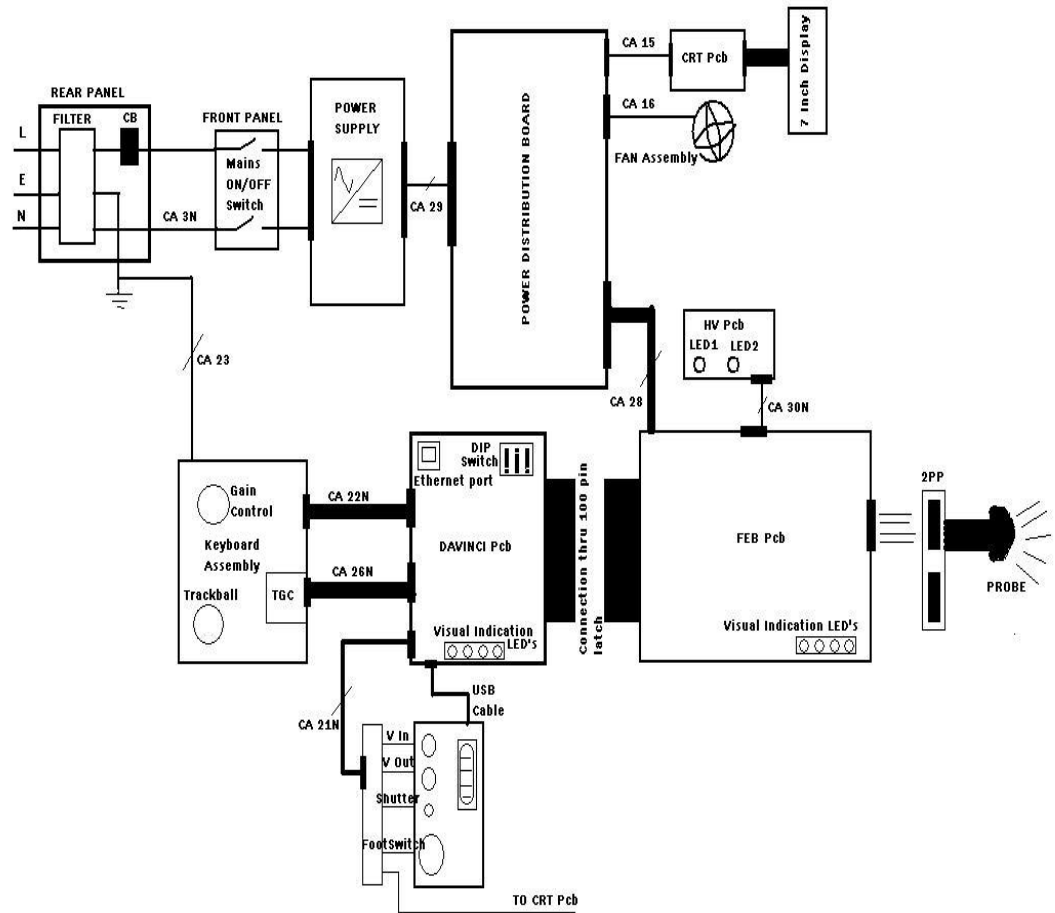

Figure 4-8 Block Diagram of Davinci board LOGIQ™ 100 PRO

5-3-2 LOGIQ™ 100 PRO BLOCK DIAGRAM.



RELEASSED UNDER CRICOP
SECTION 5-3

5-3-3 PCB Nomenclature

The following table lists the Circuit boards on LOGIQ™ 100 PRO system.

Board Abbrv	Description	Remarks
Davinci	Davinci Board	For LOGIQ™ 100 PRO (All S/W Versions)
KBD	Keyboard	For LOGIQ™ 100 PRO (All S/W Versions)
FEB	Front End Board	For LOGIQ™ 100 PRO (All S/W Versions)
PDB	Power Distributor PCB	For LOGIQ™ 100 PRO (All S/W Versions)
HVPS	High Voltage Power Supply	For LOGIQ™ 100 PRO (All S/W Versions)

Table 4-9

Section 5-4 Wiring Diagrams

5-4-0-1 Power Distributor/Power Supply Wiring Diagram

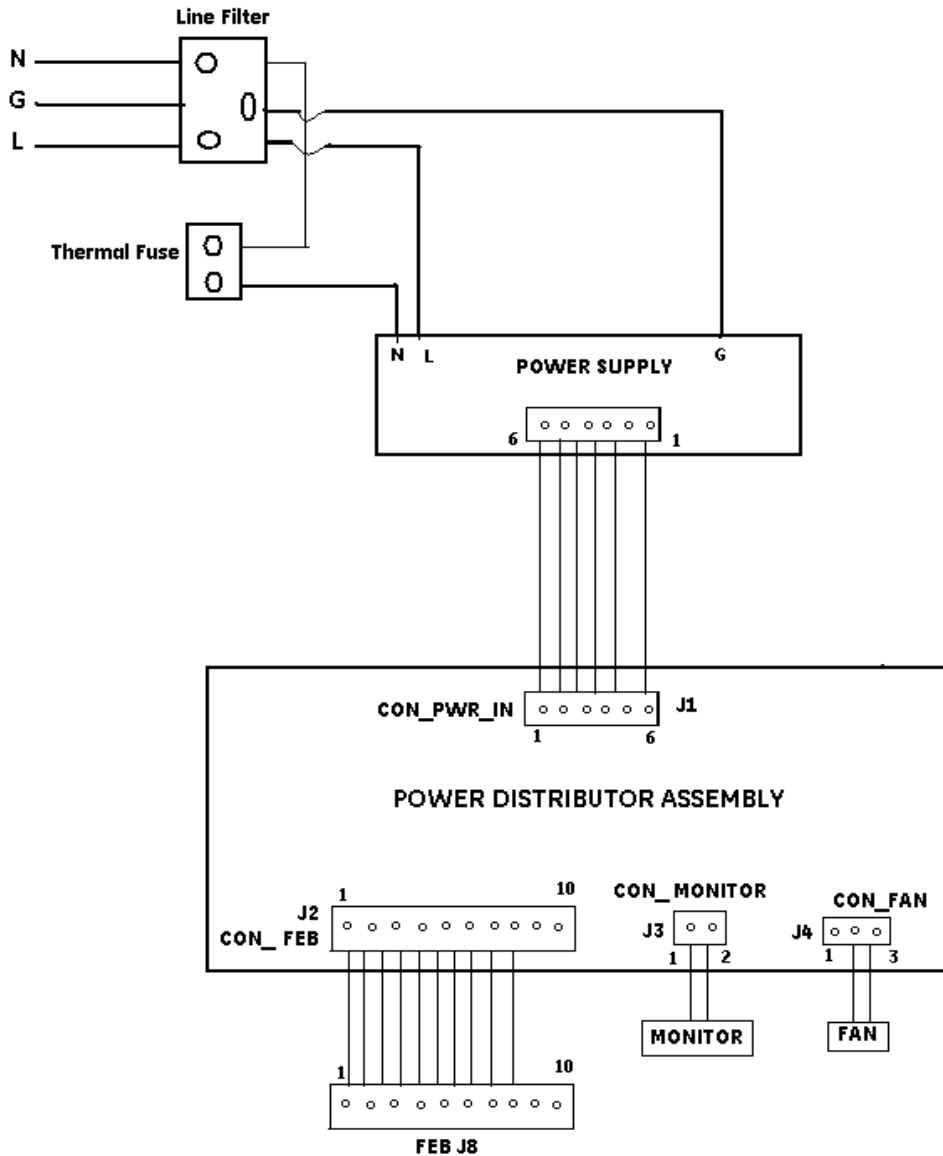

Figure 4-9 Power Distributor/Power Supply Wiring Diagram for LOGIQ™ 100 PRO.

RELEASSED UNDER
SECTION 5-4

Table 4-10 Power Distributor Connector Voltages for LOGIQ™ 100 PRO .

Connector J1 Input to PDB	Connector J2 Output	Connector J3 Output	Connector J4 Output	Power Supply Connector Output
Pin 1 - +5V in	Pin 1 - +5VD	Pin 1 - +12VD	Pin 1 - NC	Pin 1 - +5V
Pin 2 - +3.3V in	Pin 2 - Gnd	Pin 2 - Gnd	Pin 2 - +12VD	Pin 2 - +3.3V
Pin 3 - +3.3V in	Pin 3 - +3.3VD		Pin 3 - Gnd	Pin 3 - +3.3V
Pin 4 - Gnd	Pin 4 - +3.3VD			Pin 4 - Gnd
Pin 5 - Gnd	Pin 5 - Gnd			Pin 5 - Gnd
Pin 6 - +12V in	Pin 6 - Gnd			Pin 6 - +12V
	Pin 7 - +12VD			
	Pin 8 - Gnd			
	Pin 9 - -12VD			
	Pin 10 - Gnd			

Table 4-11 Power Distributor Input and Output Voltages of LOGIQ™ 100 PRO .

TEST point Locations on the FEB.

Location for Testing HV on FEB	Specification
FEB Test Point 90.	65 Vdc +/- 3Vdc.
FEB Test Point 91.	80 Vdc +/- 3 vdc.
FEB Test Point 62, 65 and 73.	12 Vdc +/- .3 vdc.
FEB Test Point 63, 67 and 70.	5 V dc +/- .3 vdc.
FEB Test Point 110.	-12V dc +/- .3 vdc.
FEB Test Point 60 and 61.	3.3 V dc +/- .03 vdc.

Table 4-12 Voltage Test points on the FEB.

NOTE : The Test point information is provided on the Base of the console, which is visible after opening the top cover.

5-4-0-2 Cable Assembly Diagrams

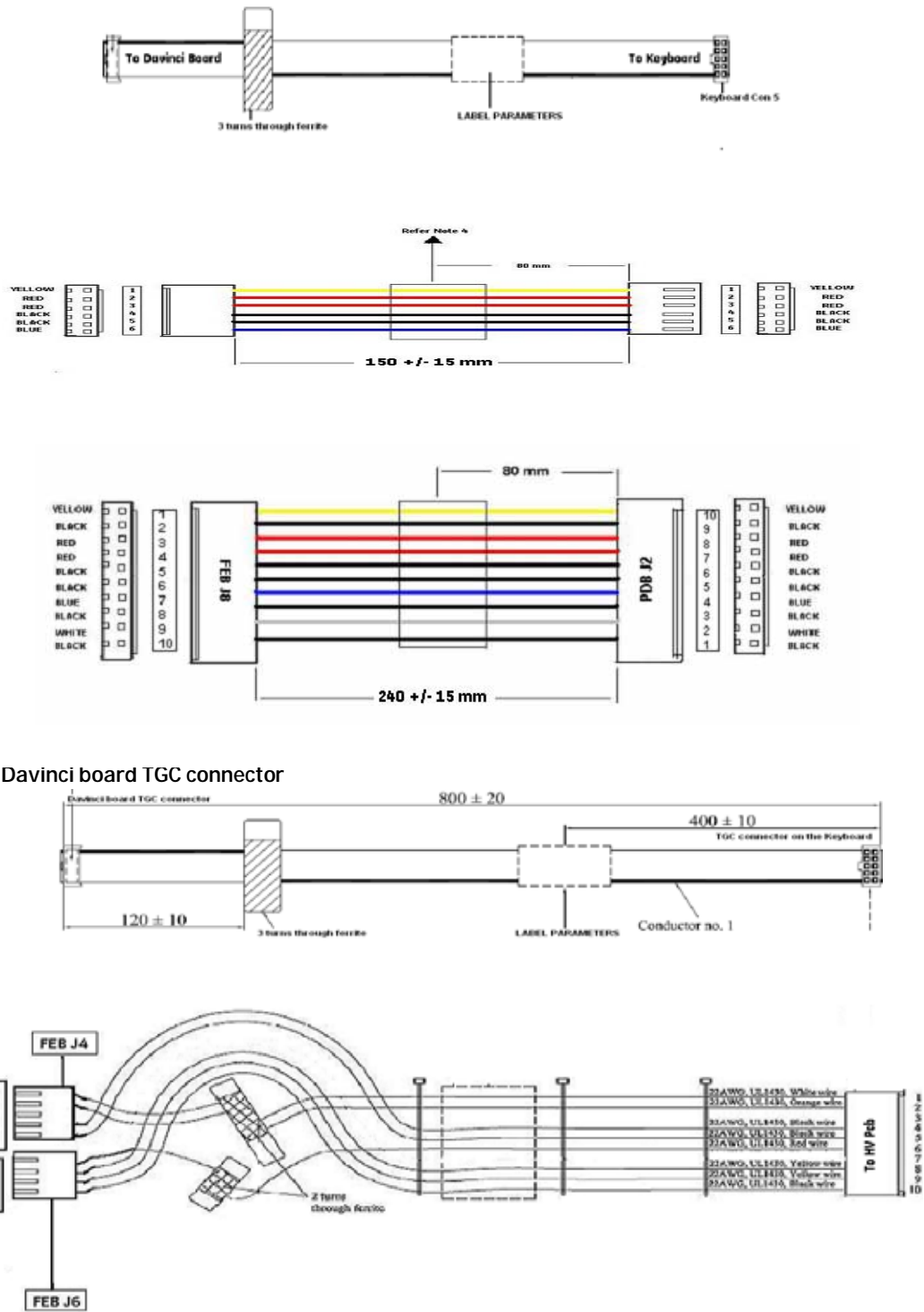

Figure 4-10 Cable Assembly Wiring Diagram

Cable Assembly Diagrams (Continued)

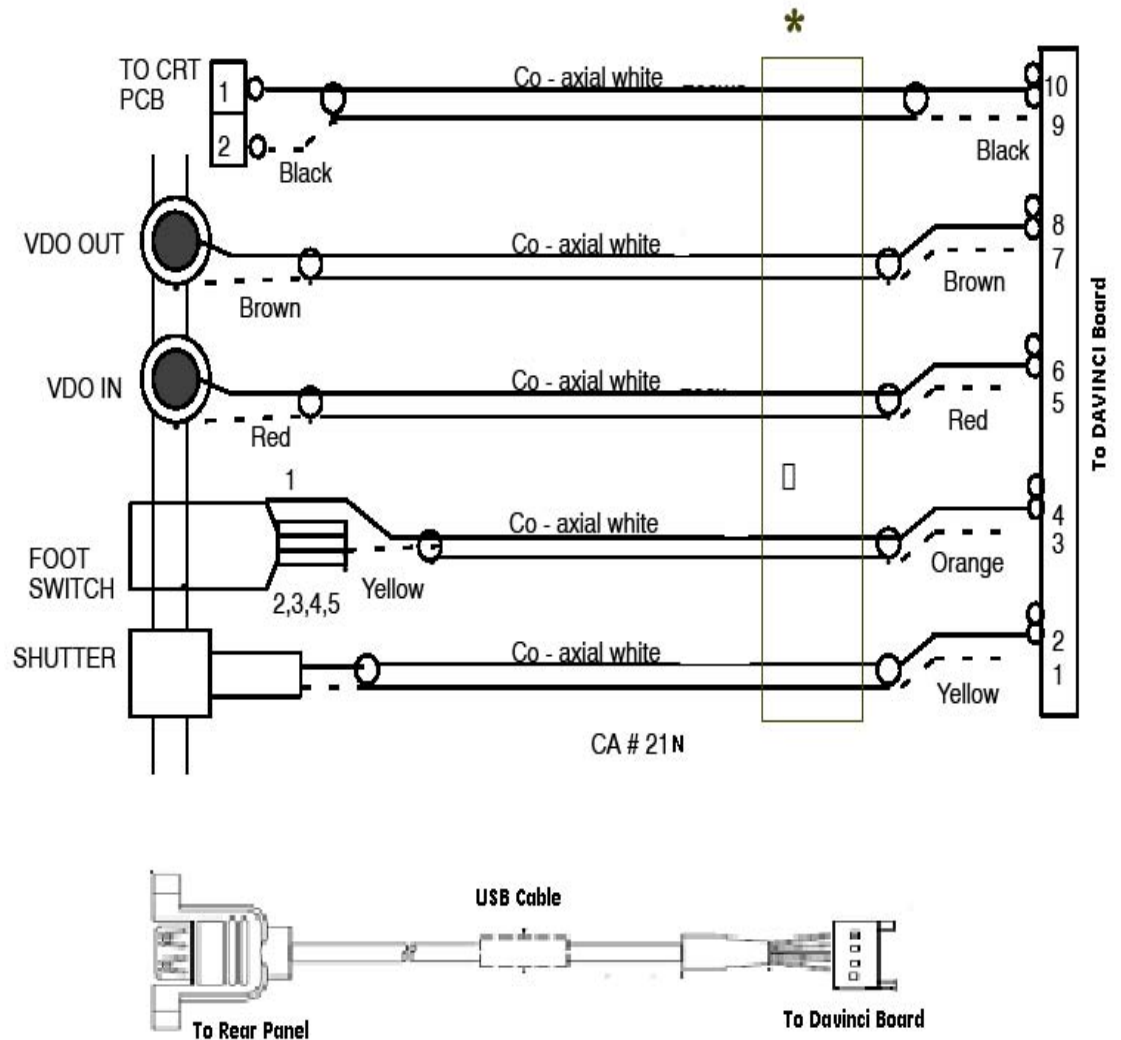

Figure 4-10

* Ferrite Core Over which wires wound 2 Turns

RELEASED UNDER E.O. 13526

Section 5-5 Functional Subsystems

5-5-1 Front End Board

The Front End Board generates the strong transmit bursts, transmitted by the probes as ultrasound into the body. It also receives weak ultrasound echoes from blood cells and body structure, amplifies the signals and converts them to an 8 bit digital signal. FEB supports 16 channels Beamformer. The beamformed data is passed through CHACOM ASIC and subsequently passed through Frame Averaging filter and Mean filter. The Output of FEB is fed to the Davinci CPU PWA through a board-to-board connector. This connector also provides power to the Davinci CPU PWA Board.

5-5-2 Davinci Board

The Davinci CPU board uses TMS320DM6446 chip that contains an ARM Processor, DSP and Video processors into a single chip.

The Major functionalities & corresponding implementation is described below.

- 1) System Memory - 256MB DDR2 Memory.
- 2) Program Storage – 16 Megabytes of NOR Flash is used to store the Boot loader code, Kernel, and Application software.
- 3) Image Storage – 64 Megabytes of NAND Flash is used to store the User Images. It is also used to store a part of Application software and operating system code.
- 4) Keyboard interface (Ultrasound keyboard I/f, PS 2 trackball interface, Gain Controller interface). Ultrasound Keyboard is interfaced to Davinci CPU PWA. The serial communication occurs at 9600-baud rate.

Optical Trackball TB_CLK and TB_DATA pins are connected to Davinci CPU PWA. Trackball supports Ps2 standard.
- GAIN Encoder - GAIN_CCW and GAIN_CW pins of the gain encoder are connected to the GPIO pins of Davinci CPU.
- 5) On Screen Display (OSD), Video Out and Monitor Display - The DAVINCI CPU generates the OSD along with the image in NTSC or PAL video output format (standard) to the Video Out and Monitor connector.
- 6) USB port interface - The Davinci CPU PWA provides one USB 2.0 Host connector. This port is used to interface Thermal Printer, DeskJet printer as well as to transfer the image to Memory stick in JPEG format.
- 7) NTSC and PAL setting - A Dipswitch is provided to select NTSC or PAL standard. This switch is available on Davinci CPU PWA.
- 8) Real Time Clock (RTC) - RTC chip is provided on Davinci CPU PWA that acts as a timekeeper i.e. it maintains the system clock and date.

5-5-3 Peripherals

VCR, Black & White Video Graphic Printer and HP Laser Jet Printer 1020 can be connected to the scanner. For more details on recommended peripherals refer Chapter 3.

Section 5-6 Video Specifications

Refer to Section 3-6-5 for more details about the Video Specifications.

Section 5-7 Rear Panel Signal List

Refer to Section 3-6-4 for more details about the rear panel signal list.

RELEASED UNDER
SECTION 552

RELEAS
SECTION

Chapter 6 Service Adjustments

Section 6-1 Overview

6-1-1 Service Adjustments Available in LOGIQ™ 100 PRO

The LOGIQ™ 100 PRO does not contain service adjustable parts. In case of failure of any module like the Power Supply, HV pcb it is recommended to replace the power supply unit instead of trying to adjust the potentiometer or replacing the fuse.

No Service Adjustments.



WARNING DO NOT ADJUST CRT POTENTIOMETERS.



WARNING Whenever Upgrade of LOGIQ™ 100 PRO is done at field, Please ensure patient data back up is done before upgrading the machine.

Your Notes:

RELEASED UNDER
SECTION 552

Chapter 7 Diagnostics/Troubleshooting

Section 7-1 Overview

7-1-1 Purpose of Chapter 7

This section describes how to setup and run the tools and software that help maintain image quality and system operation. Very basic host, system and board level diagnostics are run whenever power is applied. Some Service Tools may be run at the application level.

The LOGIQ™ 100 PRO System service diagnostics comprises of:

- 1.) Self test or power on diagnostics
- 2.) Service diagnostic tools

The self test or power on diagnostics are run every time the system is booted. The service diagnostic tools include test procedures for testing the system at PCB level as well as block level. The diagnostic tools provides a pop-up menu to enable selection of various tests to test various blocks on the system.

CONTENTS IN CHAPTER 7

Section	Description	Page Number
7-1	Overview	7-1
7-2	Power On Diagnostics	7-3
	Service Diagnostics	7-3
7-2-1	Davinci Board Test.	7-4
7-2-2	FEB Test for LOGIQ™ 100 PRO	7-7
7-2-3	Keyboard Tests	7-9
7-2-4	Monitor Test	7-10
7-2-5	Key Operation History	7-13
7-3	Error Reporting	7-14
7-4	Troubleshooting	7-15

Table 7-1 Contents in Chapter 7

LED Indications and functions of PCB's

PCB	LED Location	Function
FEB	LED - Location on FEB D65	This LED indicates the scan lines,the DSP is scanning.The LED glows when the cursor is moved in the B/M mode
FEB	LED - Location on FEB D66	This LED indicates the probe connect signal is good.This indicates the FEB is Good
FEB	LED - Location on FEB D67	This LED indicates the B mode signal is given to the display.The intensity of this LED is more during B mode.
FEB	LED - Location on FEB D68	This LED indicates the M mode signal is given to the display.This LED glows during M and B/M mode,the intensity of this LED is less during B/M mode
DAVINCI	LED - Location on Davinci CPU D12	This LED is ON during Acoustic Frame measurement switching.This also indicates the communication between the DSP and the Davinci CPU FPGA
DAVINCI	LED - Location on Davinci CPU D11	This LED indicates the Video Sync is happening.This indicates the video frame output from the Davinci CPU to the monitor is ok.
DAVINCI	LED - Location on Davinci CPU D10	This LED indicates the KEY press on the keyboard.It glows intermittantly when there is a key pressed.
DAVINCI	LED - Location on Davinci CPU D09	This LED indicates the USB connection to the Rearpanel.When a USB device or Pen drive is connected, the LED glows to indicate it is to the Davinci CPU.(USB output of the Davinci is Good)

Table 7-2 LED Indications

LED's on FEB.



LED's on DAVINCI.



UNCLASSIFIED//FOR OFFICIAL USE ONLY
 RELEASED UNDER E.O. 13526

Section 7-2 Power On Diagnostics

The power on diagnostics or self tests are run every time the system is booted. This self tests include testing the validity of the system software through EPROM checksum test and testing the system RAM. It checks whether the keyboard and the trackball are properly interfaced to the system. It also initiates the self test of analog subsystem. The two LED's on the keyboard (Freeze & Ext. Video) and the beeper are used to indicate error conditions.

Note: Power on Diagnostics works only when the system is in application (imaging) mode and not while on service diagnostics.

Service Diagnostics

Check the S/W Version of your System prior to start of the service diagnostics. The S/W version can be known during the power up Sequence.



Press (CTRL +! + S + Enter)

keys on the keyboard to enter the service diagnostics. In response, a pop-up menu appears as shown in Table 7-1

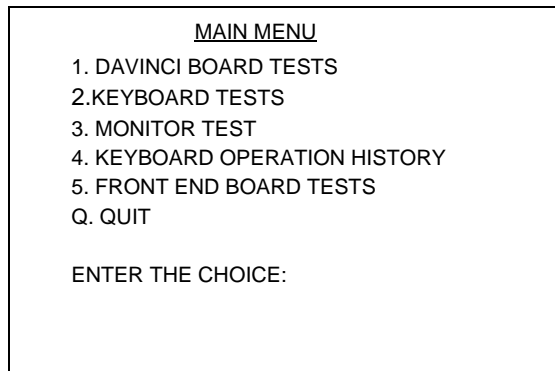

Figure 7-1 Main Menu For LOGIQ™ 100 PRO

Note: Option Q (Quit) can be used to come out of the diagnostic and enter the application mode.

7-2-1 DAVINCI Board Tests

When this test is selected the following screen will appear.

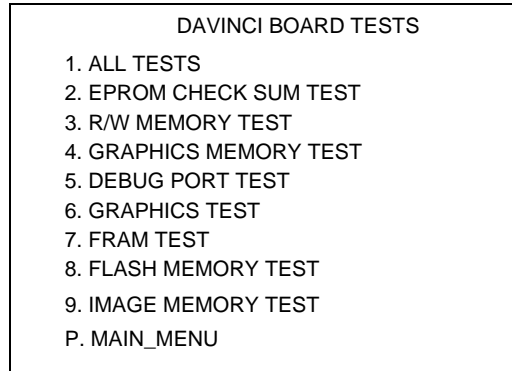

Figure 7-2 DAVINCI Board Tests

All Tests

This option is used to run all tests in the menu. Once all the tests are completed, press any key to exit.

EPROM Checksum Test

The validity of the software residing in the EPROM on the DAVINCI Board is tested by performing the Checksum test. The word Checksum of the program is computed and its one's compliment is stored in the EPROM as the last word. In this test the contents of the memory are added word wise and the computed sum is compared against zero. If the resulting sum is non-zero the test is reported to have failed.

Read/Write Memory Test

The Read/Write memory on the DAVINCI Board is tested by filling the memory with test patterns and reading them back and validating the read data. If any of the memory byte does not contain the expected data it is declared as faulty.

Graphics Memory Test

The overlay or the graphics memory is tested in the same way as Read/Write memory.

Debug Port Test

Internal Loop Back Test - In this test the port is programmed for internal loop back mode so that a byte transmitted can be received back.

DAVINCI Board Tests (Contd.,)

Graphics Test

The pattern shown below is displayed on the monitor when this test is enabled.

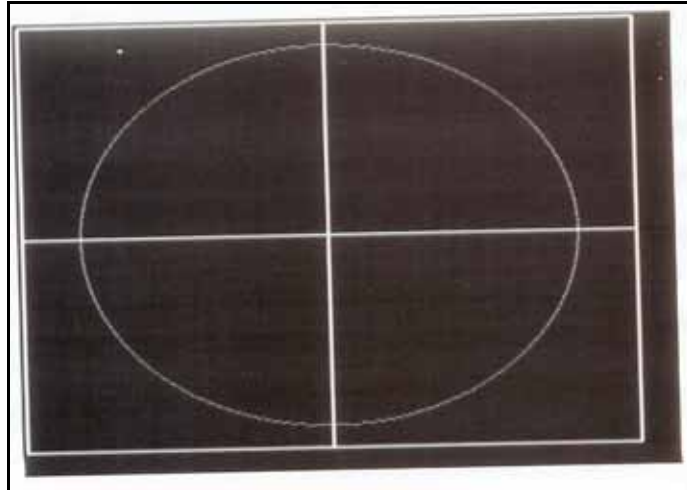

Figure 7-3 Graphics Test

Press any key to exit the Graphics Test

FRAM Test

When this test is selected the following will appear

```
TESTING NAND AND NOR FLASH

      NAND FLASH
MANUFACTURER      ID      0x20
MANUFACTURER      NAME      ST Micro
NUMBER OF BLOCKS      4096
NUMBER OF BAD BLOCKS      0
USABLE MEMORY      (IN BYTES)      67108864

      NOR FLASH
MANUFACTURER      ID      0x1
MANUFACTURER      NAME      AMD AM29LV256M

CHECKSUM TEST PASSED
PRESS ANY KEY TO QUIT
```

Figure 7-4 FRAM TEST

Note: WRITING SUCCESSFUL and READING SUCCESSFUL indicate FRAM test is Passed.

DAVINCI Board Tests (Contd.,)

Flash Memory Test

The Following Menu is Displayed

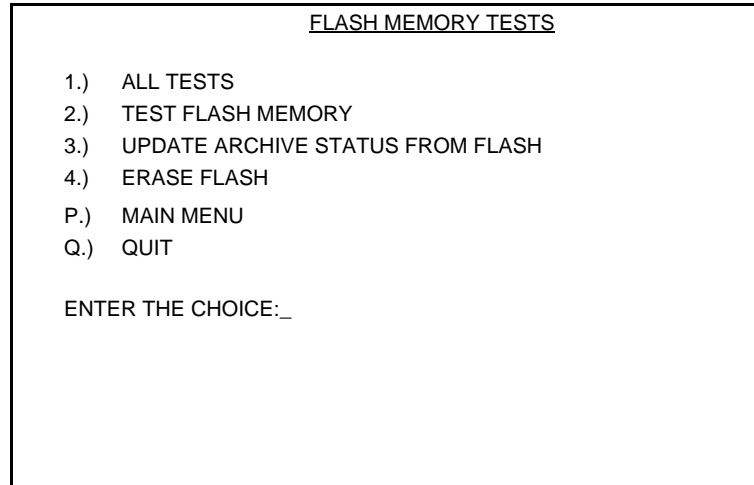

Figure 7-5 FLASH MEMORY TESTS

All Tests

This option is used to run all tests in the menu.

Test Flash memory banks

This test programs one image location in each bank and reads them back. This is done to check the functionality of all Image_select and Bank_select signals. The failure in any bank is indicated by the error message "FAILED". Else the message "OK" is displayed.

Update archive status from flash

The Davinci soft ware stores and keeps updating status information on all available flash image slots.

This status info is stored in the FRAM. When we run this option. The Davinci will check the Flash and update its status stored in FRAM.

Note: This option must be run during the following instance without fail

A.) Take a back up of the archive before the system is upgraded to a higher version of software.

DAVINCI Board Tests (Contd.,)

Erase Flash memory

When this option is run all the images stored in the flash is erased.

Main Menu

This option is used to return to the main menu.

Quit

This option is used to come out of the diagnostic and enter the application mode.

Image memory tests:

The image memory is tested in the same way as the memories on the CPU board

Cine memory test

All the Cine frames have been tested one by one by writing 4 test patterns and then reading the same.

Main menu

This option is used to return to the main menu

Quit

This option is used to come out of the diagnostic mode and enter the application mode.

7-2-2 FEB Test for LOGIQ™ 100 PRO

When self test for the FEB is selected, the DPRAM on the FEB Board will be written on and read back. Read data is checked for validity. This will prove the communication between FEB & Davinci boards.

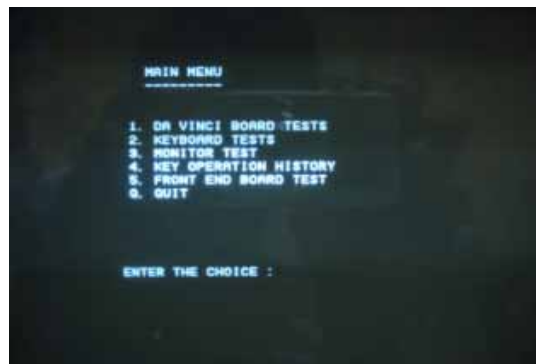

All Tests

This option is used to run all tests in the menu. Once all the tests are completed, press any key to exit.

Observe the FEB test pattern on the screen.

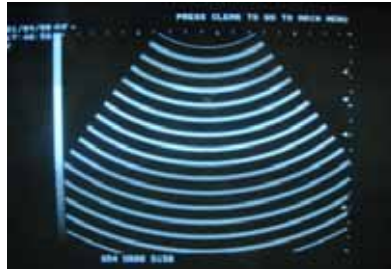

Change the modes to B/B, B/M and M modes and check for the proper display of the FEB Test pattern.

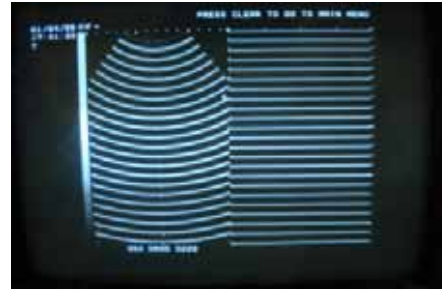
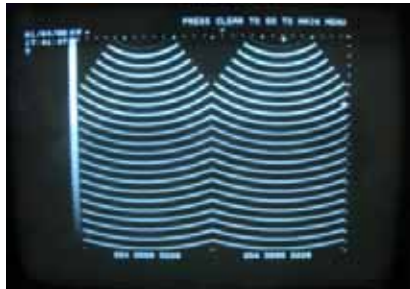

To exit from this mode press CLEAR on the keyboard.

7-2-3 Keyboard Tests

When this Option is selected following Menu appears

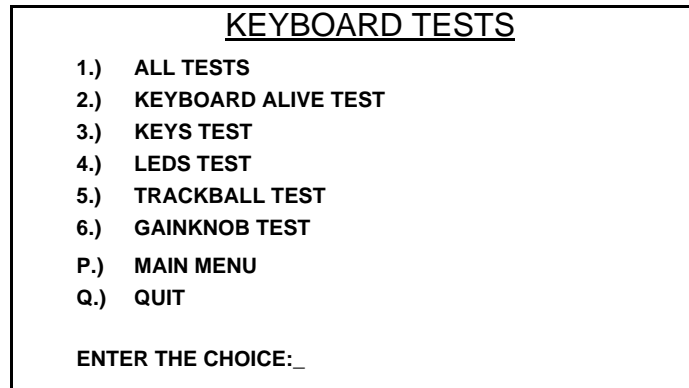

Figure 7-6 Keyboard Tests

All Tests

This option is used to run all tests in the menu.

Keyboard Alive Test

In this test, keyboard alive condition is tested by interacting with the keyboard firmware directly. This test is done to check the communication with the Davinci.

Keys Test

In this test, all the keys in the keyboard can be tested. The user is prompted to press the keys on the keyboard and the pressed keys are highlighted on the screen. (This is a toggle operation).

Note: During Keys Test Press "Ext. Video" at the last. Pressing "Ext. Video" key interrupts the test and return to main keyboard Tests Menu.

LEDS Test

During this test *FREEZE* field and *EXTERNAL VIDEO* field will be displayed on the monitor. The *FREEZE* and *EXTERNAL VIDEO* LEDs blink for a while sequentially and the corresponding field gets highlighted.

Trackball Test

A cursor is displayed on the monitor and the user can move the trackball and move the cursor over the screen.

Gain Knob Test

In this test, the user can check for the operation of the gain knob. The current gain value is displayed on the screen.

Main Menu

This option is used to return to the main menu.

Quit

This option is used to come out of the diagnostic and enter the application mode.

7-2-4 Monitor Test

The following test patterns are displayed on the monitor when this test is enabled. Please match the patterns displayed on your monitor with the given patterns figures 7-7 to 7-13. The Gain Knob is used for selection of patterns 1-10. To exit out of any pattern and return to the main menu, press *EXTERNAL VIDEO*.

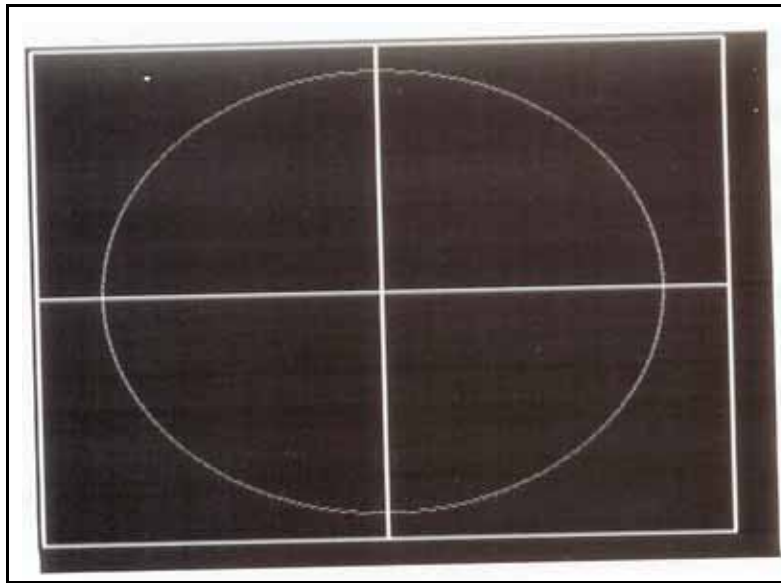

Figure 7-7 Monitor Test

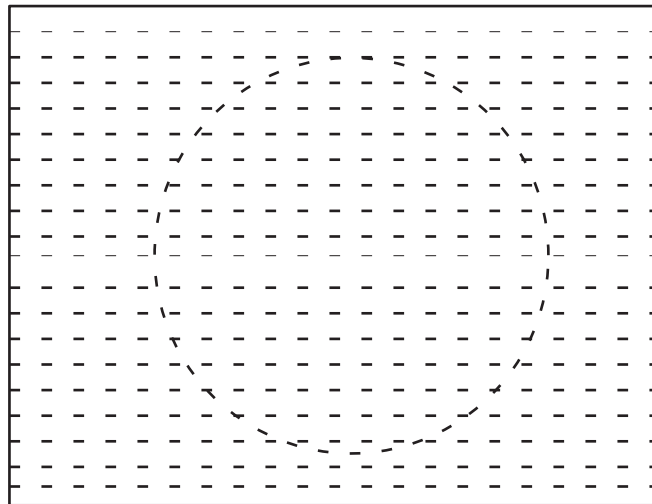

Figure 7-8 Monitor Test

Monitor Test (Contd.,)

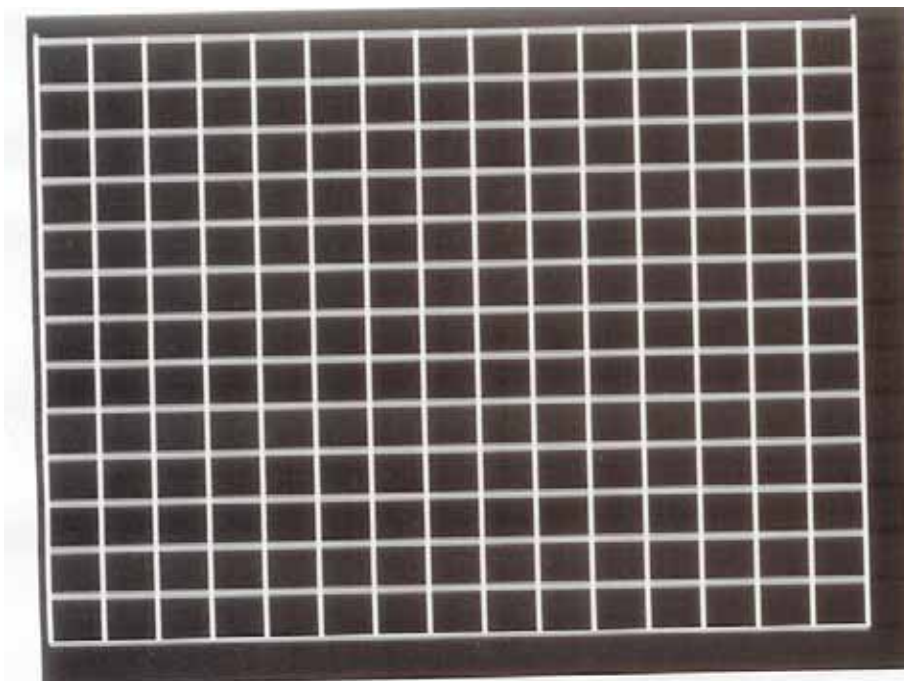

Figure 7-9 Monitor Test

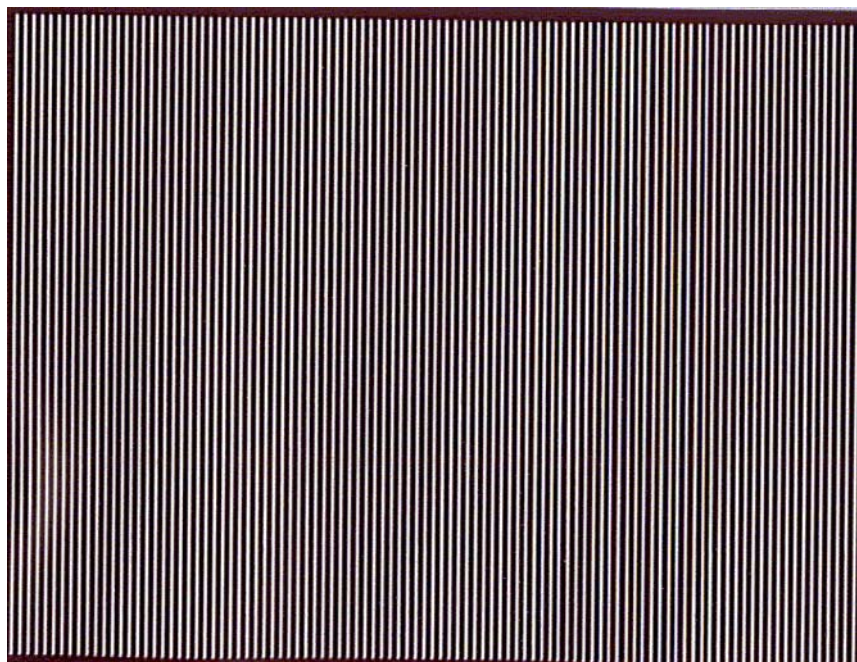

Figure 7-10 Monitor Test

Monitor Test (Contd.,)

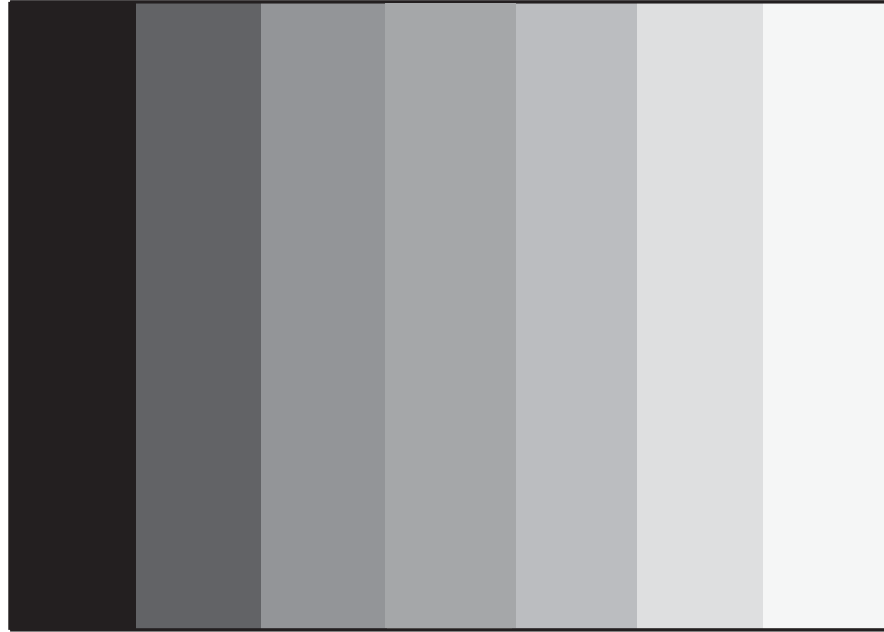

Figure 7-11 Monitor Test

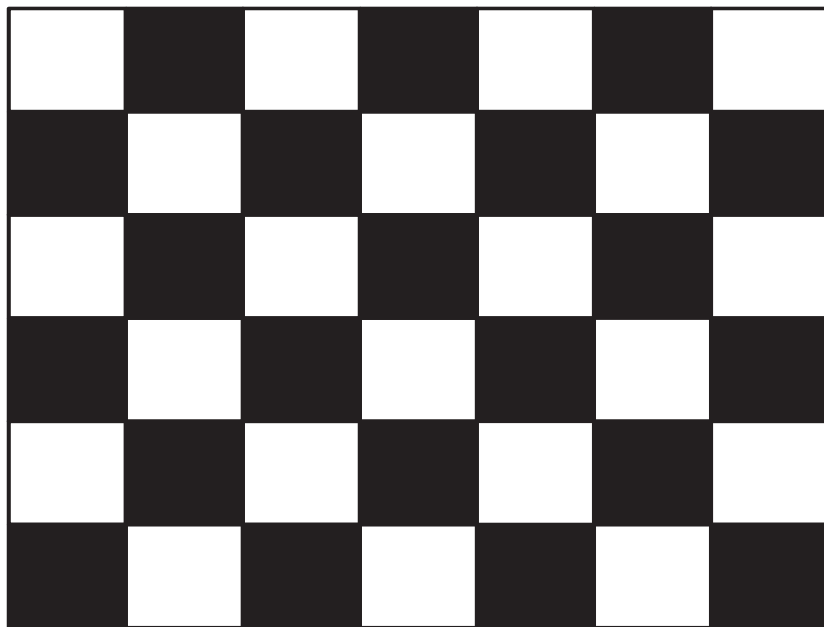

Figure 7-12 Monitor Test

Monitor Test (Contd.,)

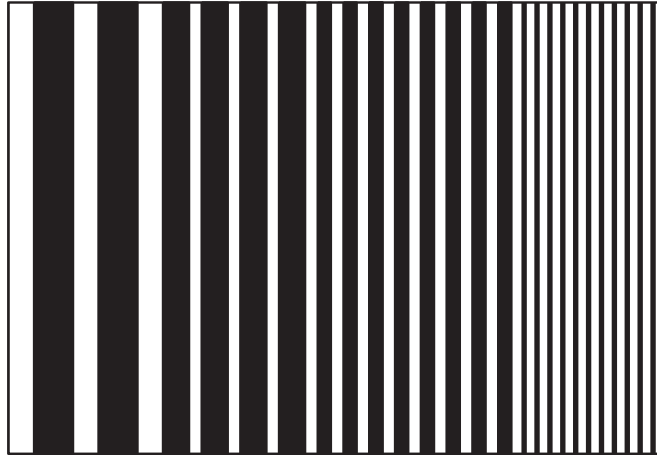

Figure 7-13 Monitor Test

Note: The patterns in 7-7 to 7-10 are written on the overlay where as the pattern in 7-11 to 7-13 is written on the image memory.

7-7 to 7-9 are also available in reverse video

7-2-5 Key Operation History

When this option is selected from the Main Menu the following appears indicating a maximum of 32 keys last activated. The history of keys used is stored even after powered off.

KEY OPERATION HISTORY	
KEY OPERATED	KEY OPERATED
1.	17.
2.	18.
3.	19.
4.	20.
5.	21.
6.	22.
7.	23.
8.	24.
9.	25.
10.	26.
11.	27.
12.	28.
13.	29.
14.	30.
15.	31.
16.	32.

PRESS EXT_VIDEO TO QUIT

Figure 7-14 Key Operation History

Section 7-3 Error Reporting

7-3-1 Error Reporting

The following are the error messages available:

Errors	Remarks
"THE KEYBOARD SUBSYSTEM FAILED TO RESPOND"	This Message is displayed during the diagnostics of the Keyboard. When the keyboard firmware is not alive, this message is displayed.
"KEYBOARD NOT CONNECTED"	If the keyboard is not connected then this message is displayed during system boot up.
"TRACKBALL INTERFACE ERROR"	This message is displayed during system boot up and the trackball interface to keyboard is not proper.
"NO TRACKBALL ACKNOWLEDGEMENT"	This message is displayed during system boot up and keyboard connection is not there.
"PLEASE POWER OFF AND RESTART THE SYSTEM! "	This message is displayed when the system boots up in the normal mode and any error which needs the system to be restarted comes up.
"PRINTER IS BUSY"	This message comes up when shift + record is pressed without connecting the printer. Only for LOGIQ™ 100 PRO
"PRINTER ERROR"	This message comes up when an error occurs in the printing process.
"PRINTING ABORTED"	This message is displayed during Printing & due to printer error. Only for LOGIQ™ 100 PRO
"WARNING: THIS WILL ERASE ALL IMAGES! 1:YES 2:NO"	This message is displayed when the '3 '(Clear ALL) is pressed after going to the recall screen. Only for LOGIQ™ 100 PRO.
"ARCHIVE FULL "	This message is displayed when the store key is pressed while the archive(USB) is full. Only for LOGIQ™ 100 PRO.
"USB IS NOT READY"	This message is displayed when shift + store is pressed without connecting the USB. Only for LOGIQ™ 100 PRO.
"USB TRANSFER ERROR"	This message is displayed when some error occurs in the USB transfer process. Only for LOGIQ™ 100 PRO.

Table 7-3 Error Messages

Section 7-4 Troubleshooting

The following table is provided to help the service engineer during corrective maintenance.

TROUBLESHOOTING

Problem Faced	Cause	Solution
No Display, total black out	No AC Power Circuit Breaker tripping Brightness/Contrast knobs may be at end limit No video signal to the monitor Monitor may be defective Power Supply to the Monitor may be bad (12 Volts) Davinci or FEB may be defective.	Ensure power cable is ok and there is power at the wall outlet Power Supply or PCB may be loading. Replace the defective power supply or the PCB Turn the knobs to the suitable position Ensure video cable connection from the Davinci to the monitor pcb is intact Feed an external video signal to confirm Set right the same Replace the same
"No trackball Acknowledgement" or "Trackball Interface error" - Error message	Trackball or the cable maybe defective Keyboard or Davinci or interface cable may be defective	Replace appropriately. Contact your local service representative for further information on this. Replace appropriately
"Keyboard not connected" - Error message	Keyboard to Davinci interface cable may be defective. Keyboard may be defective. If the EXT Video LED and the FREZZE LED are glowing simultaneously during Boot Up then the keyboard may be defective.	Replace the same Replace the same Replace the same
"No System Mode Acknowledgement" - Error message	Davinci interface may not be proper	Replace FEB or Davinci pcb
No Text	Davinci may be defective	Replace the Davinci
No Echoes otherwise system is ok	HV Power Supply maybe defective, Connection of the CA 30N may be loose. FEB maybe defective. During some boot ups the DSP application may not be fully loaded.	Check for the cable assembly 30N. Replace the HV Power Supply Replace the FEB If this problem appears reboot the system.
System does not respond to Gain variation	Cable interfacing Davinci and KBD maybe defective. Davinci or FEB maybe defective If overlay updated then Davinci is good Gain Encoder may be defective	Replace the same Replace appropriately Replace Keyboard Assembly
Garbled Text Display	Davinci overlay problem	Replace Davinci

Table 7-4 Trouble Shooting

Problem Faced	Cause	Solution
System Resets intermittently	3.3 Volt power supply may be less.	a. First check for the 3.3V DC supply to the CPU board & ensure Proper Voltage. b. If the voltage is not at required level, Proceed to check if the power supply is a problem or the Davinci board. c. If the voltage is ok then check for the connection between the Davinci board and FEB. d. If still not working relplace the boards appropriately.
Display shrinks and/or shakes	Problem maybe with monitor or power supply to the monitor	Replace appropriately
Image blooming	If only image area (Problem maybe with HV Power supply or FEB. If problem is with full monitor display	Replace appropriately Replace the monitor
Ring artefacts on the monitor in the near field in Air scan.	Due to pickup signal when the probe is connected in air scan.	Connect the probe and scan to check the ring artifacts on an organ.
Low Frequency moving artefacts	AC line interference	Change the AC input , Check for proper grounding.
Video-In/Video Out not working	Connection on the rear panel not ok Davinci maybe defective	Set right the same Replace the same
Foot switch not working	Connection on the rear panel not ok Davinci maybe defective	Set right the same Replace the same
Remote Control not working	Rear panel or Davinci maybe defective Connection on the rear panel not OK	Replace appropriately Replace appropriately
"Image Archive Full" message not appearing. But the archive is full and image cannot be stored.	The memory size allocated for Image storage is full due to uneven size of the stored images.	Transfer all the archived images to memory stick from the recall menu. Go to service diagnostics and Erase Flash Memory in the Davinci Test menu.

Table 7-4 Trouble Shooting

RELEASED UNDER E.O. 13526
 SECTION 1.4

Machine Not Booting

Machine Not Booting

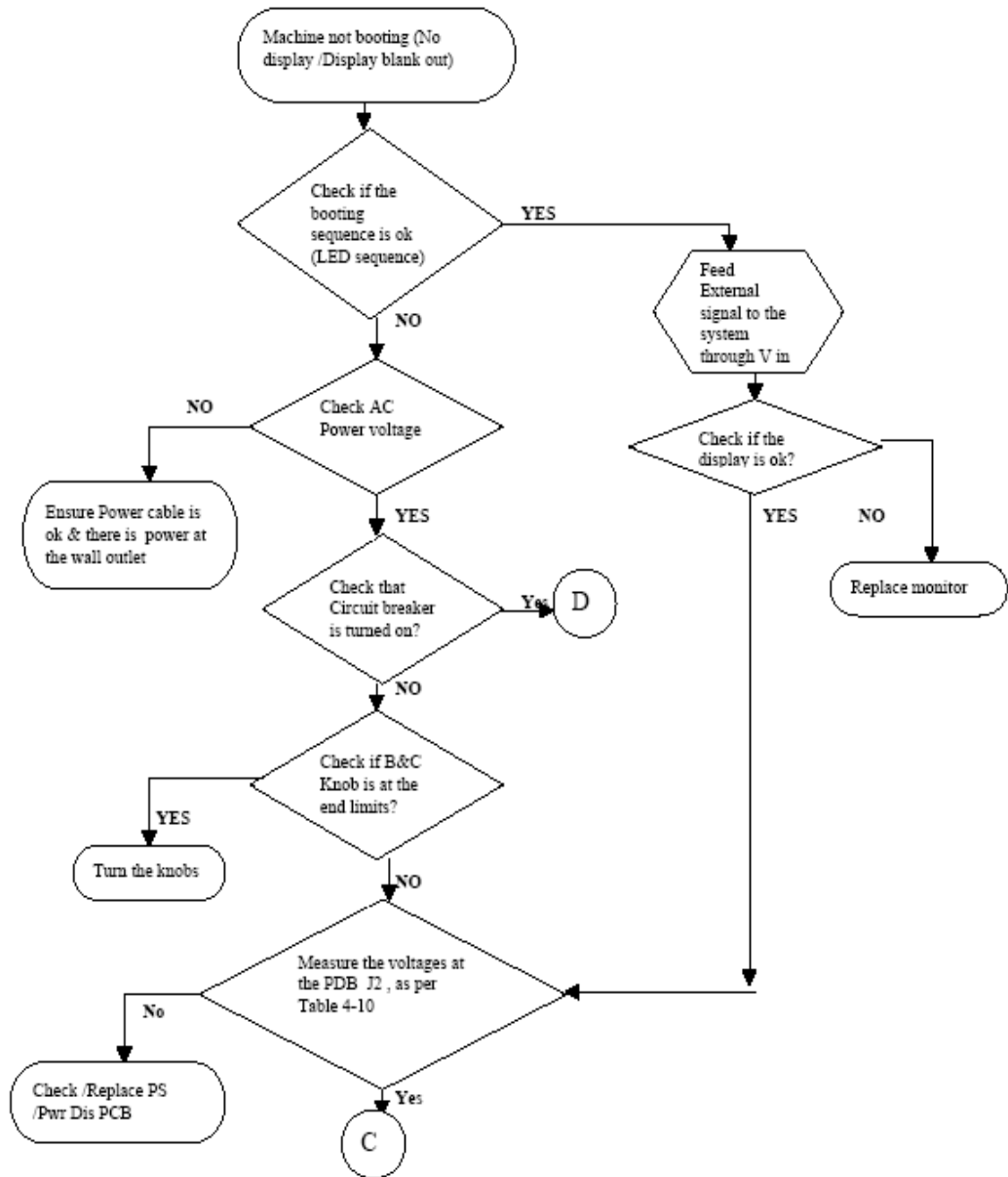

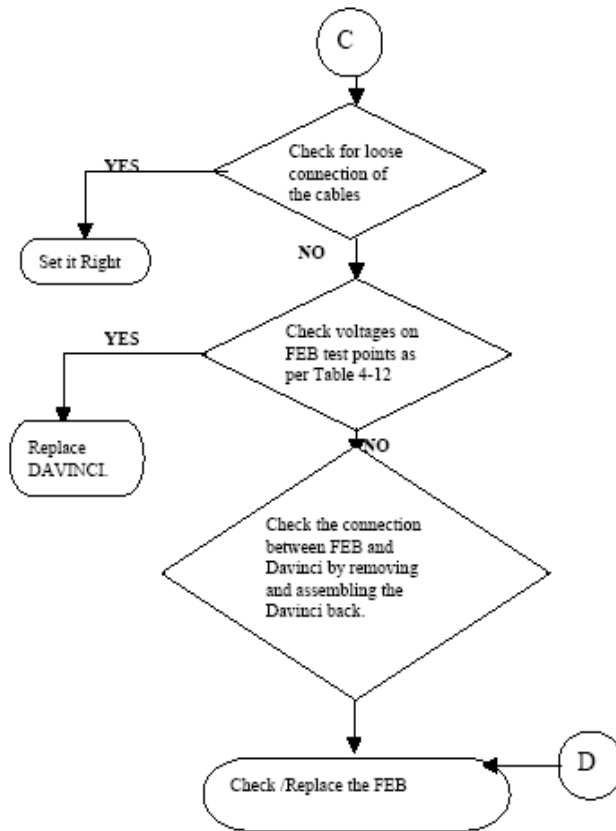

RELEASSED UNDER CRECOPI SECTION

Machine Resets Intermittently

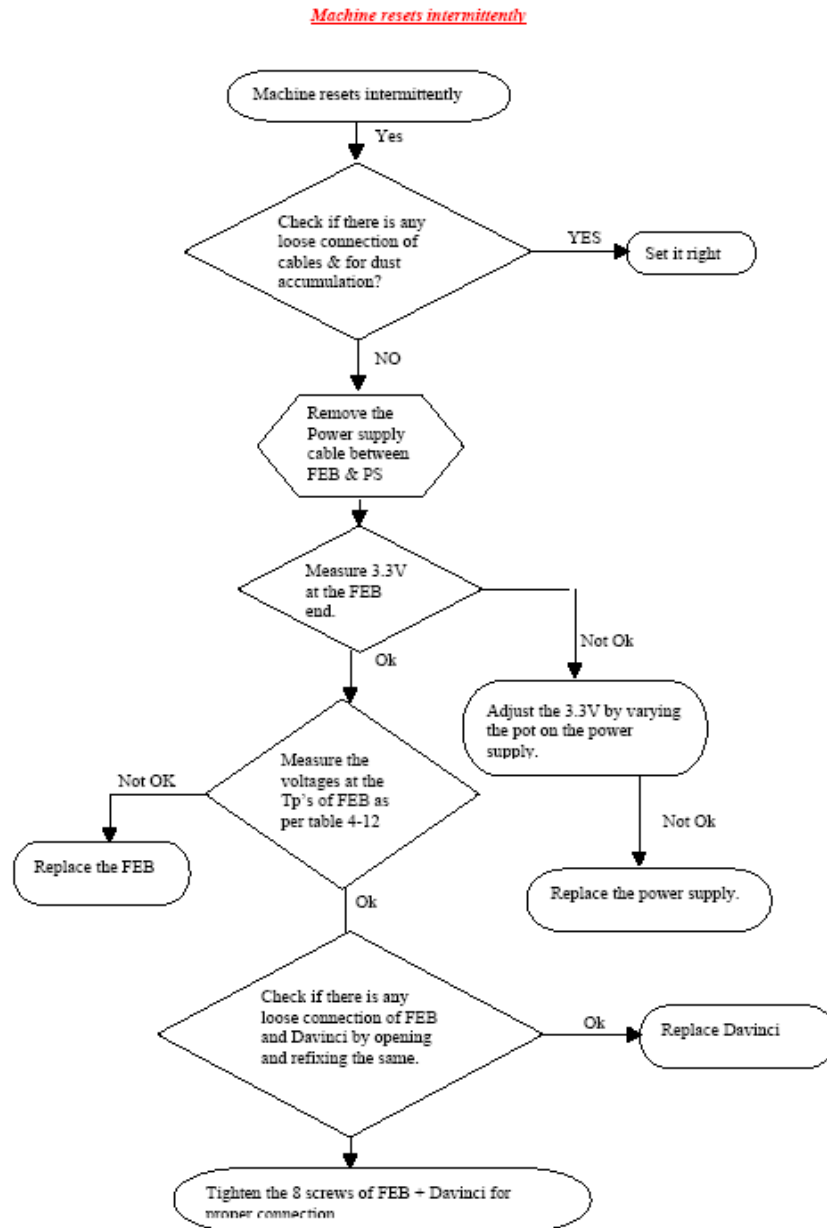

Junk Image in the Scan Area

Junk Image within scan image area.

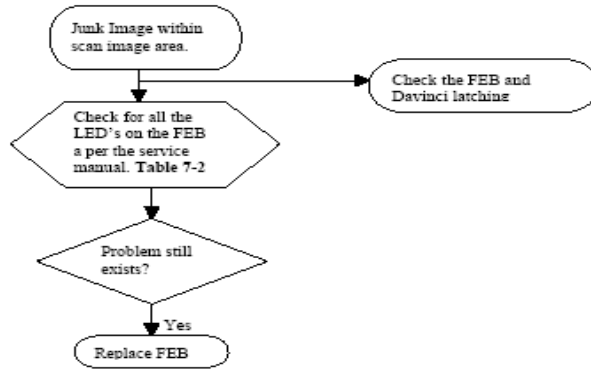

Language and Date not getting updated.

Language Date not getting updated

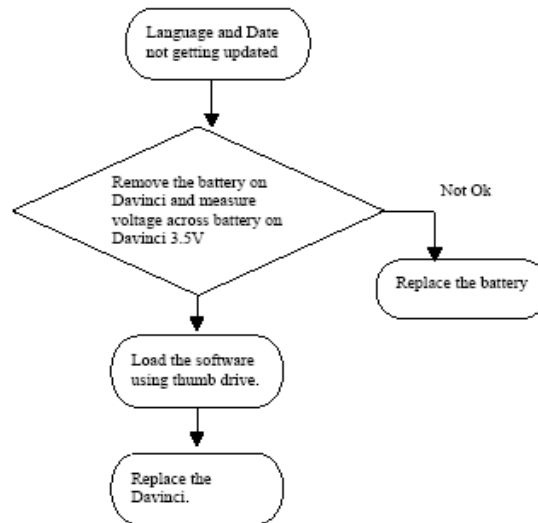

No Scan Image, Probe is firing.

No Scan Image(Probe is Firing)

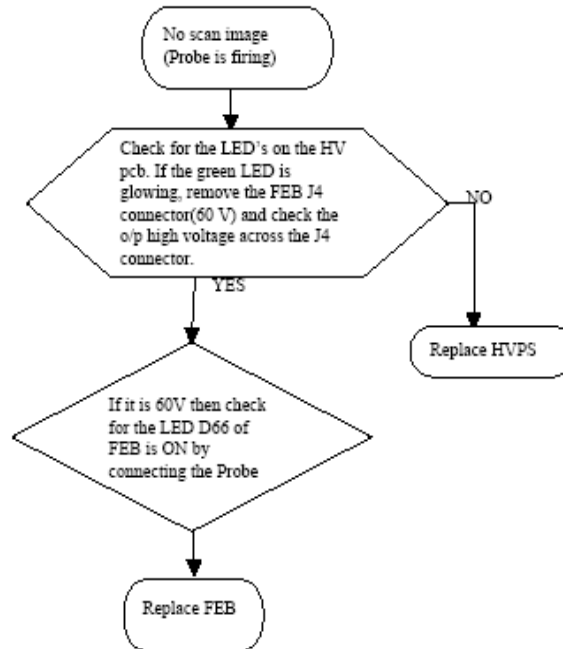

Your Notes:

RELEASED UNDER
SECTION 552

Chapter 8 Replacement Procedures

Section 8-1 Overview

8-1-1 Purpose of Chapter 8

This chapter holds replacement procedures for the following modules/subsystems.

CONTENTS IN CHAPTER 8

Section	Description	Page Number
8-1	Overview	8-1
8-2	Top Cover (FRU 101)	8-2
8-3	KEYBOARD (FRU 201)	8-4
8-4	FRONT PANEL/MONITOR (FRU 401/501)	8-10
8-5	PCBs	8-14
8-5-1	Disassembly/Assembly of Davinci Board. (FRU 601/603/604/1433)	8-14
8-5-2	Disassembly/Assembly of FEB for LOGIQ™ 100 PRO (FRU 703)	8-18
8-6	Fan Assembly (FRU 901)	8-20
8-7	Power Supply/Distributor PCB (FRU 801/802)	8-21
8-8	Rear Panel (FRU 1001)	8-21
8-9	HV Assembly (FRU 1101)	8-24
8-10	Chassis (FRU 1201)	8-25

Table 8-1 Contents in Chapter 8

Section 8-2 Top Cover

8-2-1 Disassembly/Assembly of Top Cover

Follow the steps below and refer Figure 8-1, For FRU Details refer 9-1-2

- 1.) Always Shut Down the System when disassembling the TOP COVER
- 2.) Disconnect the power cord from the mains and remove from the system.
- 3.) Remove Probe, which is at the right side of the base.
- 4.) Remove the probe holder.
- 5.) Remove two screws (a,b) at the side of the probe holder.
- 6.) Move the unit to the edge of the table and remove two screws (e,f) from the bottom of the unit.
- 7.) Remove the handle cap by pulling upward and remove the handle screws (c,d).
- 8.) Slide the top cover backward by holding the handle.
- 9.) For assembly follow the reverse order.

Service Manual Section	Functional Test/ Diagnostic Test	Debrief Script
4-2-1	Power ON/ Boot up	Service manual direction 5305880-100, Section 8-2-1. Equipment passed all required tests and is ready for use.
4-2-1	Power OFF/ Shut down	
4-3	Functional Checks	

Table 8-2 Functional tests

Disassembly/Assembly (Cont'd.)

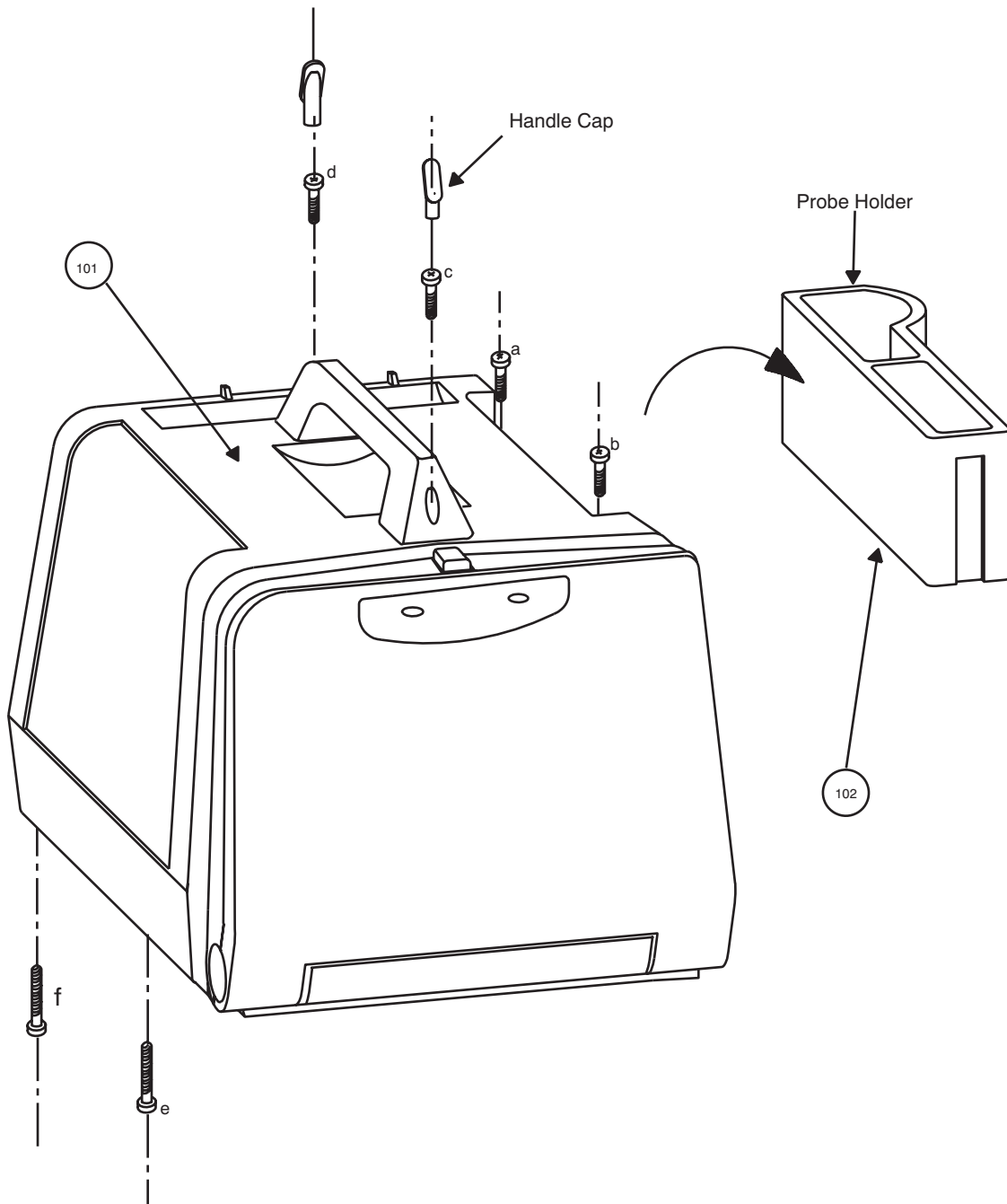

Figure 8-1 Disassembly/Assembly of Top Cover

Section 8-3KEYBOARD

8-3-1 Detaching the Keyboard

Follow the steps below and refer Figure 8-2. For FRU Details refer 9-1-3

- 1.) Remove Front Panel. Refer 8-4-1.
- 2.) Remove 14-pin connector from the Davinci.
- 3.) Remove the black ground cable coming from the keyboard along with the 14 pin flat cable connected to the chassis.
- 4.) Remove the TGC connector from the Davinci.
- 5.) Place a rubber mat below the unit and tilt the unit upward. Remove two screws (a,b) from the bottom hinge of the keyboard and remove the bottom hinge cover refer Figure 8-2.
- 6.) Press the lock release and turn the keyboard 90°. Move the keyboard downward and carefully pull out the cable with the connector.
- 7.) Remove the 2 ring bushes refer Figure 8-2.
- 8.) For assembly follow the reverse order.

Service Manual Section	Functional Test/ Diagnostic Test	Debrief Script
4-2-1	Power ON/ Boot up	Service manual direction 5305880-100, Section 8-3-1. Equipment passed all required tests and is ready for use.
4-2-1	Power OFF/ Shut down	
4-3	Functional Checks	
7-2-3	Keyboard Diagnostics tests	

Table 8-3 Functional tests

Detaching the Keyboard (Cont'd.)

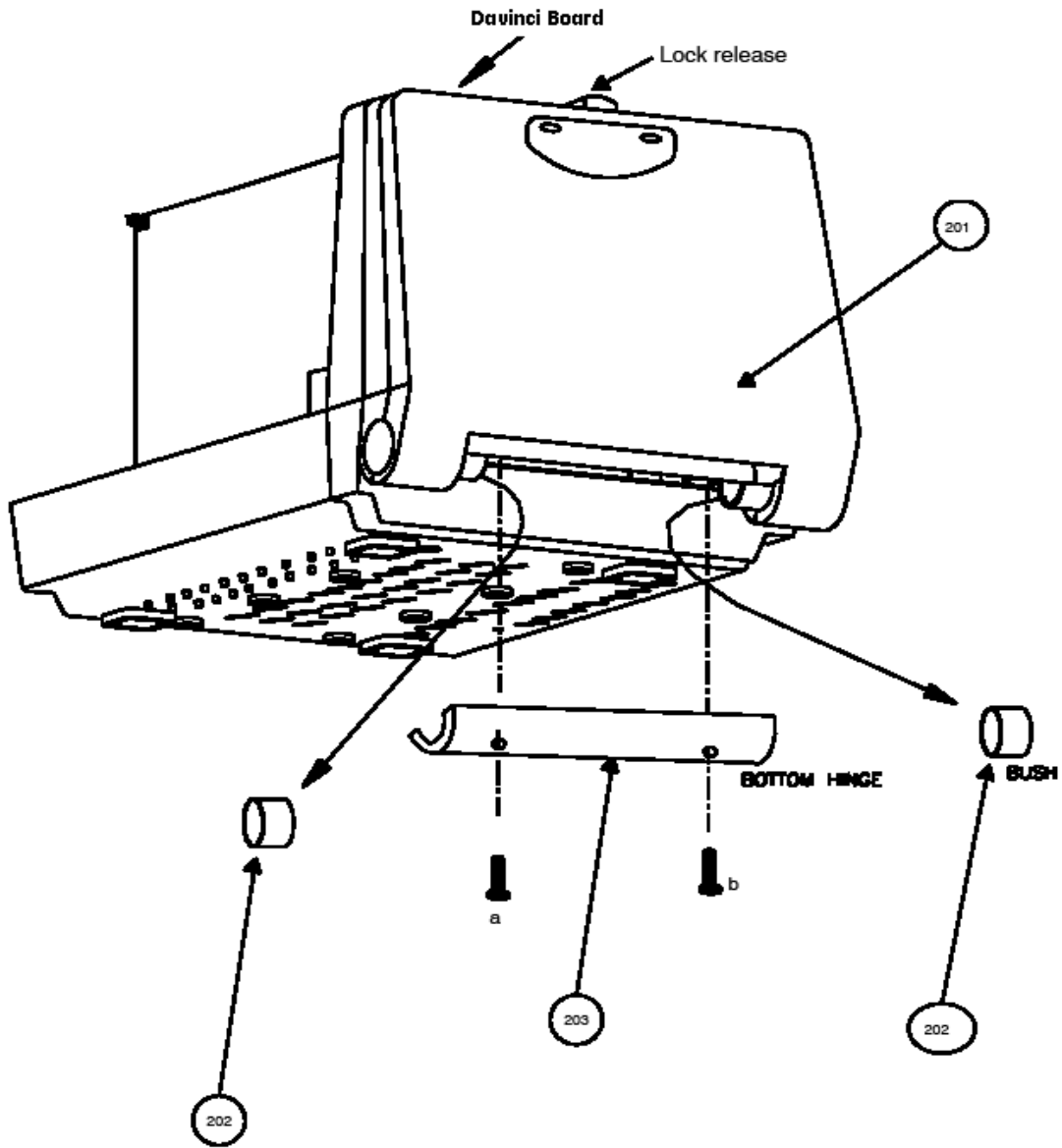

Figure 8-2 Detaching the Keyboard

8-3-2 Keyboard Disassembly/Assembly

Follow steps below and refer Figure 8-3 . For FRU Details refer 9-1-4

- 1.) Remove Top Cover. Refer 8-2.
- 2.) Detach the keyboard. Refer 8-3-1.
- 3.) Remove the spacer pad (refer FRU NO. 308 in the 8-7) which is near the lock release.
- 4.) Remove four screws a,b,c,d (b, is not visible in diagram).
- 5.) Remove keyboard top with PCB assembly.
- 6.) Remove the eight fixing screws (e to l) on the base plate.
- 7.) Remove the Gain knob (use allen key for M2.6 grub screw)
- 8.) Remove trackball mounting by removing two screws (man) and take out the trackball.
- 9.) Remove the TGC connector from the Davinci Board (for LOGIQ™ 100 PRO).
- 10.) Remove Gain Encoder connector.
- 11.) Remove the two screws (o,p) holding the Gain Encoder Unit.
- 12.) Remove eleven screws (q x 11 Nos.) holding the keyboard PCB to the base plate to separate the keyboard PCB.
- 13.) For assembly follow the reverse order.

Note: When assembling the PCB to the base plate, M3x6 screws **only** should be used because a wrong screw used will pierce the key sheet.

Service Manual Section	Functional Test/ Diagnostic Test	Debrief Script
4-2-1	Power ON/ Boot up	Service manual direction 5305880-100, Section 8-3-2.Equipment passed all required tests and is ready for use.
4-2-1	Power OFF/ Shut down	
4-3	Functional Checks	
7-2-3	Key board Diagnostics tests	

Table 8-4 Functional tests

Keyboard Assembly/Disassembly (Cont'd.)

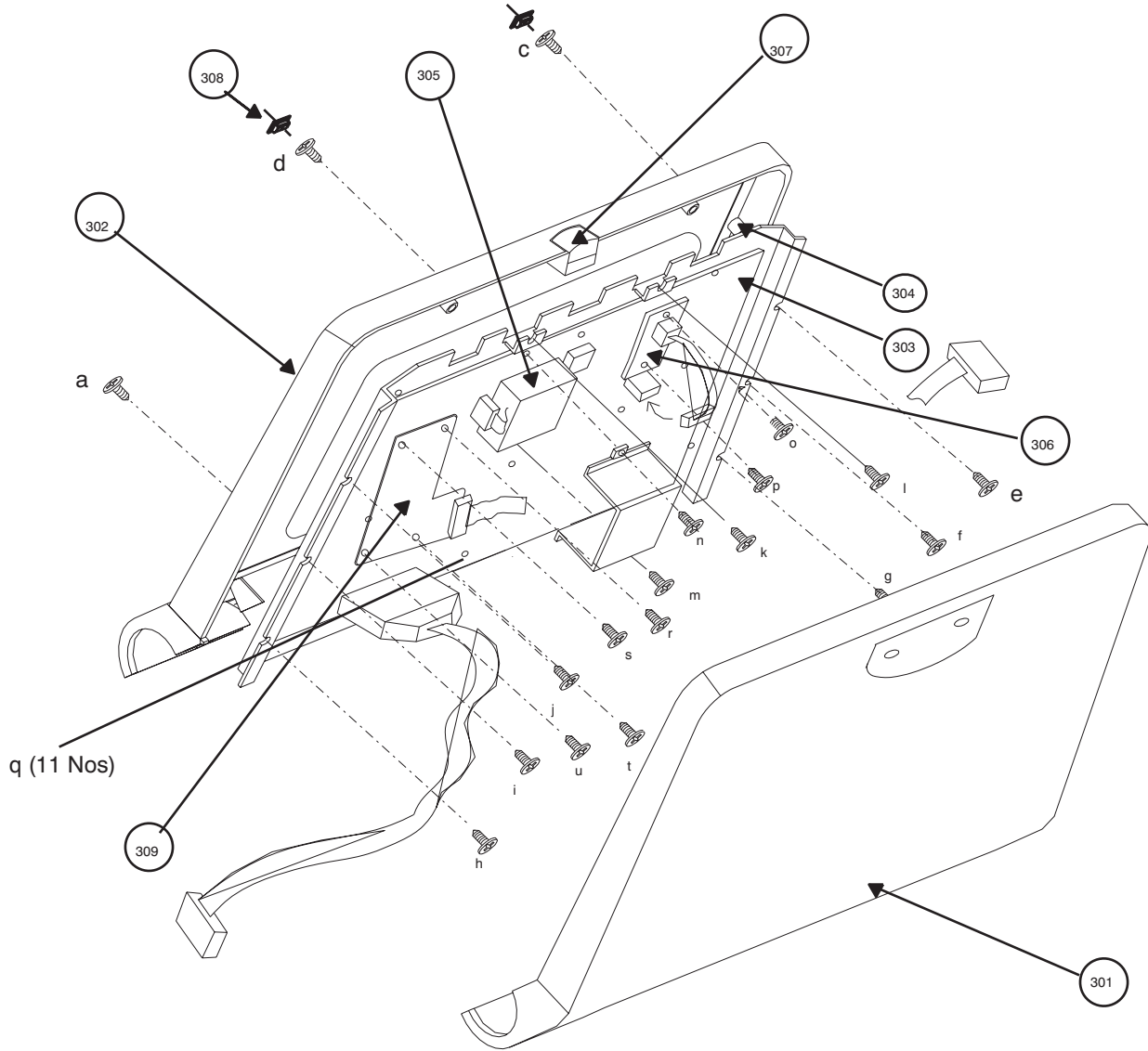

Figure 8-3 Keyboard Disassembly

8-3-2-1 Optical Trackball Assembly

Procedure for LOGIQ™ 100 PRO

- 1.) Assemble TB Base Pad 2230750 (x). Refer Figure 8-4
- 2.) Assemble Optical Trackball PCB Assembly 2224019 (y) refer Figure 8-4
- 3.) Ensure that Trackball alignment is OK on the Key sheet.
- 4.) Assemble Trackball bracket assembly 22244032 (z) refer Figure 8-4
- 5.) Fix screws a,b & c at the location A,B & C in keyboard base plate.
- 6.) Fix the FPC cable 2139504 (D) as shown in Figure 8-4
- 7.) For assembly the keyboard PCB follow the reverse order of Section 8-3-2.

Note:

*When assembling the PCB to the base plate, M3x6 screws **only** should be used because a wrong screw used will pierce the key sheet.*

- 8.) For initializing the Optical Trackball Select Alps Trackball from the Trackball Selection Menu in Service Diagnostics

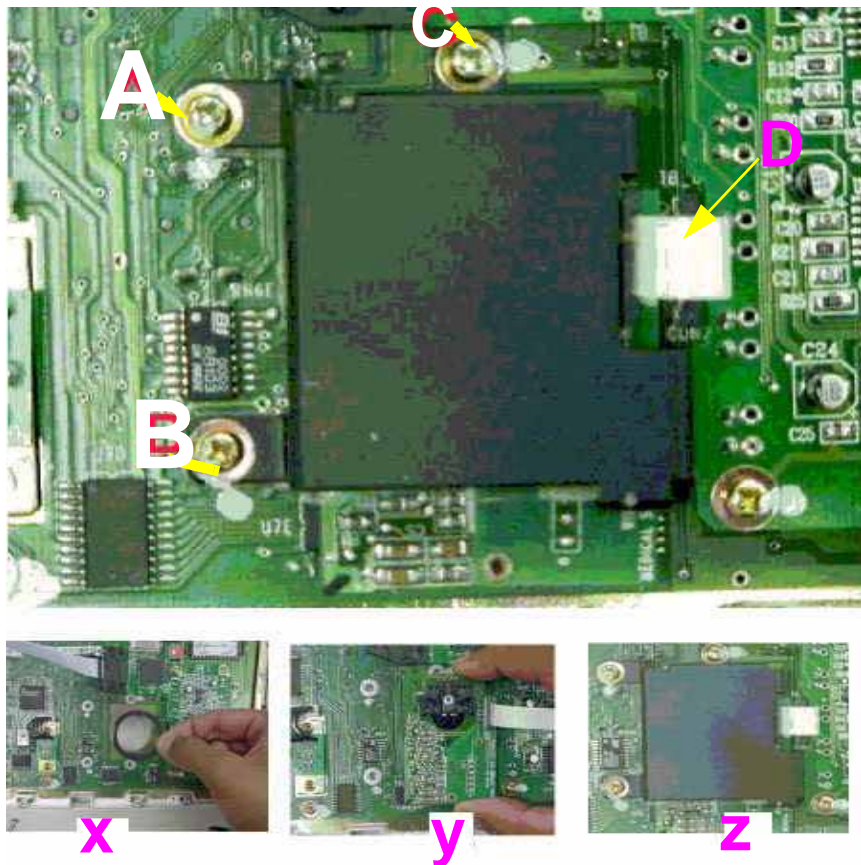

Figure 8-4 Optical Trackball Assembly

8-3-2-2 Optical Trackball Assembly

Procedure for LOGIQ™ 100 PRO

Assemble TB Base Pad 2 2222115. Refer Figure 8-5

- 9.) Assemble Optical Trackball PCB Assembly 2224019 refer Figure 8-5
- 10.) Ensure that Trackball alignment is OK on the Key sheet.
- 11.) Assemble Trackball bracket assembly 2224020 refer Figure 8-5
- 12.) Fix screws a, b & c at the location a, b & c in keyboard base plate.
- 13.) Fix the FPC cable 2139504 (C) as shown in Figure 8-5
- 14.) For assembly the keyboard PCB follow the reverse order of Section 8-3-2.

Note: When assembling the PCB to the base plate, M3x6 screws **only** should be used because a wrong screw used will pierce the key sheet.

- 15.) For initializing the Optical Trackball Select Alps Trackball from the Trackball Selection Menu in Service Diagnostics

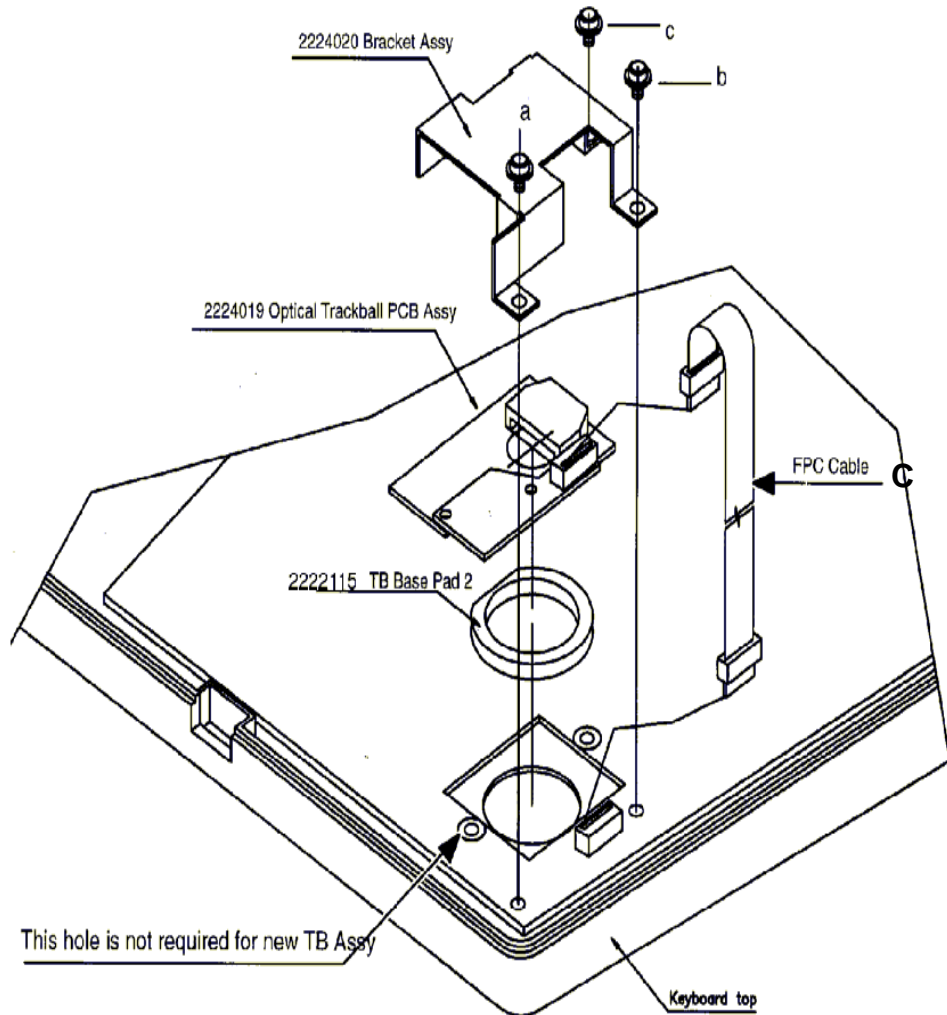

Figure 8-5 Optical Trackball Assembly for LOGIQ™ 100 PRO

Section 8-4 FRONT PANEL/MONITOR

8-4-1 Disassembly/Assembly of Front Panel

Follow steps below and refer Figure 8-6 For FRU Details refer 9-1-5

- 1.) Remove Top Cover. Refer 8-2
- 2.) Lock the Keyboard before removing the front panel.
- 3.) Remove the keyboard connector from the Davinci Board.
- 4.) Remove the black ground cable coming from the keyboard .
- 5.) Remove Brightness and Contrast connector from the Brightness and Contrast PCB. (Refer Detail 2 in the 8-11)
- 6.) Remove two screws (e,f) and detach the bottom hinge of the keyboard.
- 7.) Remove two screws (a,b) from the base along the rib.
- 8.) Remove two screws (c,d) from the support plate on the chassis.
- 9.) Disconnect the connector coming from the POWER ON Switch.
- 10.) Slide the front panel and keyboard sub-assembly together.
- 11.) For assembly follow the reverse order.

Table 8-5 Functional tests

Service Manual Section	Functional Test/ Diagnostic Test	Debrief Script
4-2-1	Power ON/ Boot up	Service manual direction 5305880-100, Section 8-4-1.Equipment passed all required tests and is ready for use.
4-2-1	Power OFF/ Shut down	
4-3	Functional Checks	
7-2	Diagnostics tests	

Disassembly / Assembly of Front Panel (Cont'd.)

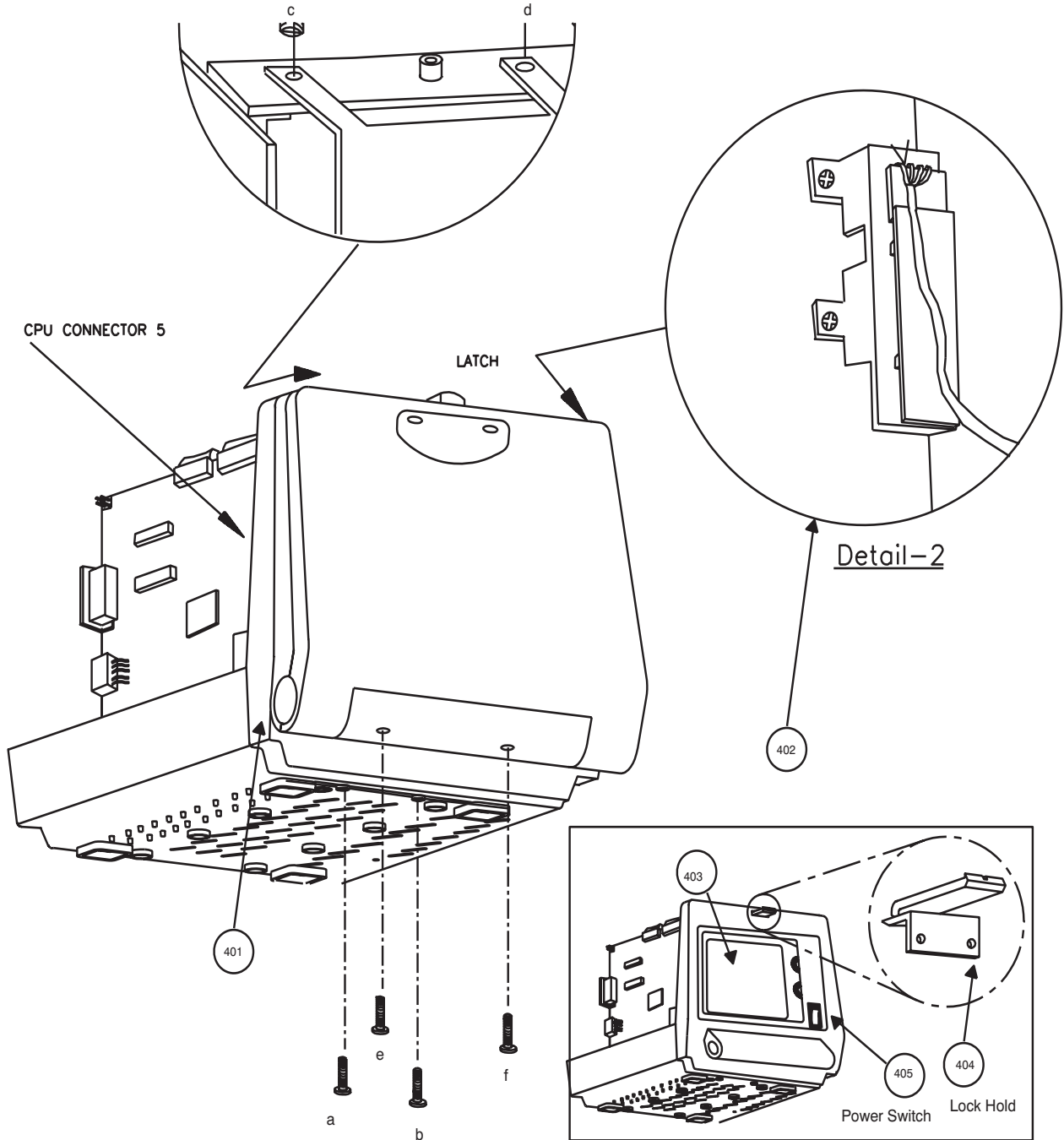

Figure 8-6 Assembly & Disassembly of Front Panel.

8-4-2 Disassembly/Assembly of Monitor

Follow steps below and refer Figure 8-7. For FRU Details refer 9-1-6

- 1.) Remove Top Cover. Refer 8-2
- 2.) Remove Front Panel. Refer 8-4-1
- 3.) Disconnect the communication cables between the Analog and Digital circuits.
- 4.) Remove Shield Plate.
- 5.) Remove the communication cable - VIDEO IN (b), Brightness/Contrast (i,j) and the power cable (a) on the CRT PCB.
- 6.) Remove the 2 screws (c,d) holding the CRT drive PCB to the chassis.
- 7.) Remove 4 screws (e,f,g,h) holding the CRT Assy connected to the chassis.
- 8.) Move the CRT forward along with CRT driver PCB assembly.
- 9.) For assembly follow the reverse order.

Note: Ensure that the monitor switch (all the four) near Fly Back Transformer is set to PAL side in case of PAL systems and to NTSC side in case of NTSC systems.

Note: If CRT fails replace along with PCB

Table 8-6 Functional tests

Service Manual Section	Functional Test/ Diagnostic Test	Debrief Script
4-2-1	Power ON/ Boot up	Service manual direction 5305880-100, Section 8-4-2. Equipment passed all required tests and is ready for use.
4-2-1	Power OFF/ Shut down	
4-3	Functional Checks	
7-2-4	Diagnostics tests	

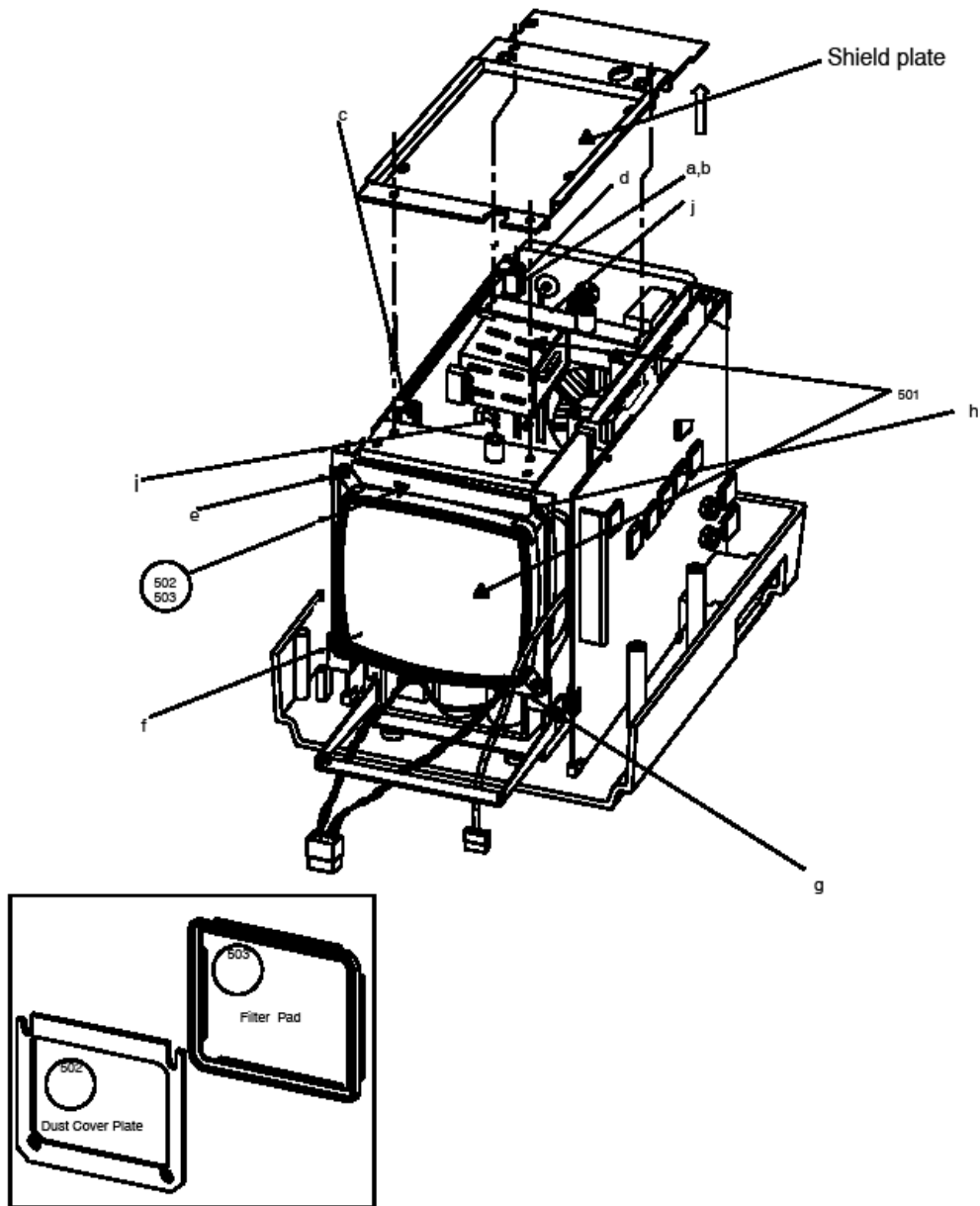

Figure 8-7 Disassembly/Assembly of Monitor

Section 8-5 PCBs

8-5-1 Disassembly/Assembly of Davinci Board.

Follow steps below and refer

- 1.) Remove Top Cover. Refer 8-2. For FRU Details refer 9-1-7 to 9-1-9
- 2.) For disassembling both Davinci Board and FEB Board together, remove all communications and power cables from the Davinci board and FEB board.
- 3.) Remove two screws to detach the PCB Assembly from the chassis.
- 4.) Pull the Davinci and FEB boards upward.
- 5.) For Davinci Board only, remove four screws (four from the Davinci board) and detach the Davinci board separately from the flush connector on the FEB.
- 6.) For assembly follow the reverse order.

Table 8-7 Functional tests

Service Manual Section	Functional Test/ Diagnostic Test	Debrief Script
4-2-1	Power ON/ Boot up	Service manual direction 5305880-100, Section 8-5-1. Equipment passed all required tests and is ready for use.
4-2-1	Power OFF/ Shut down	
4-3	Functional Checks	
4-5	Software configuration check	
7-2	Diagnostics tests	

Disassembly/Assembly of Davinci Board.

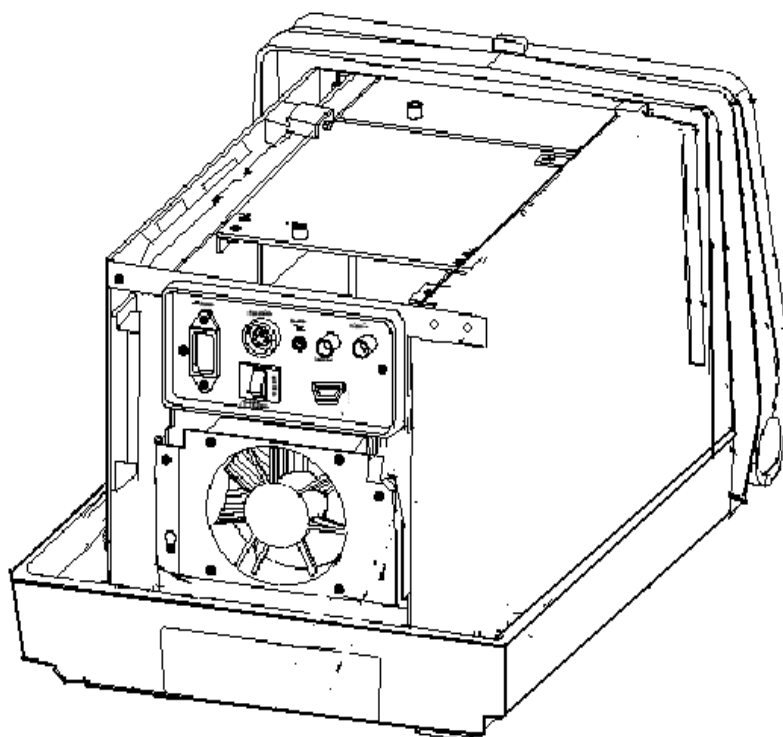

Figure 8-8 Disassembly/Assembly of Davinci Board.

Disassembly/Assembly of Davinci Board(Cont'd).

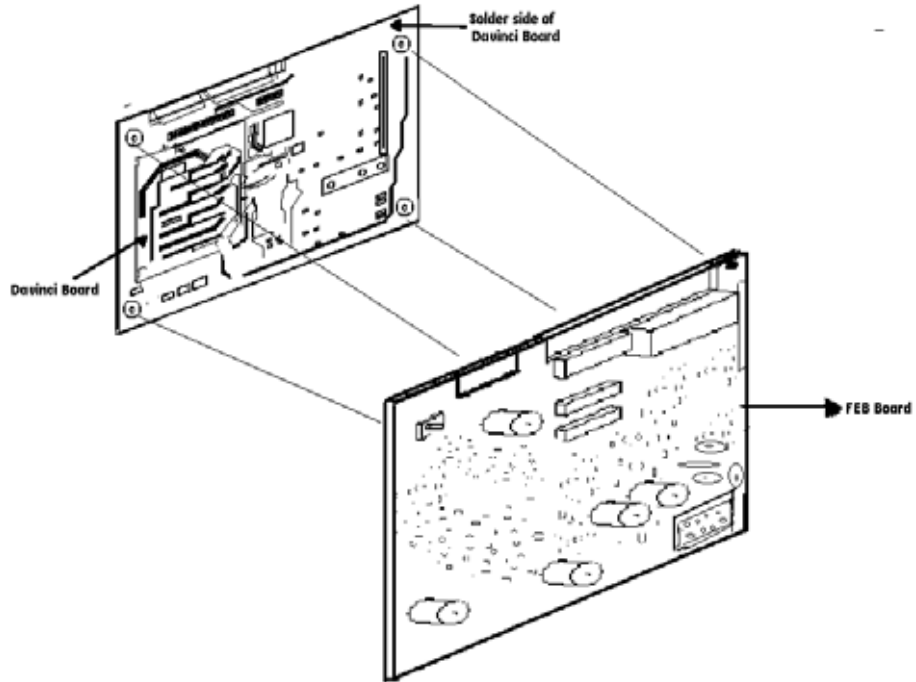

Figure 8-9 Davinci Board Disassembly

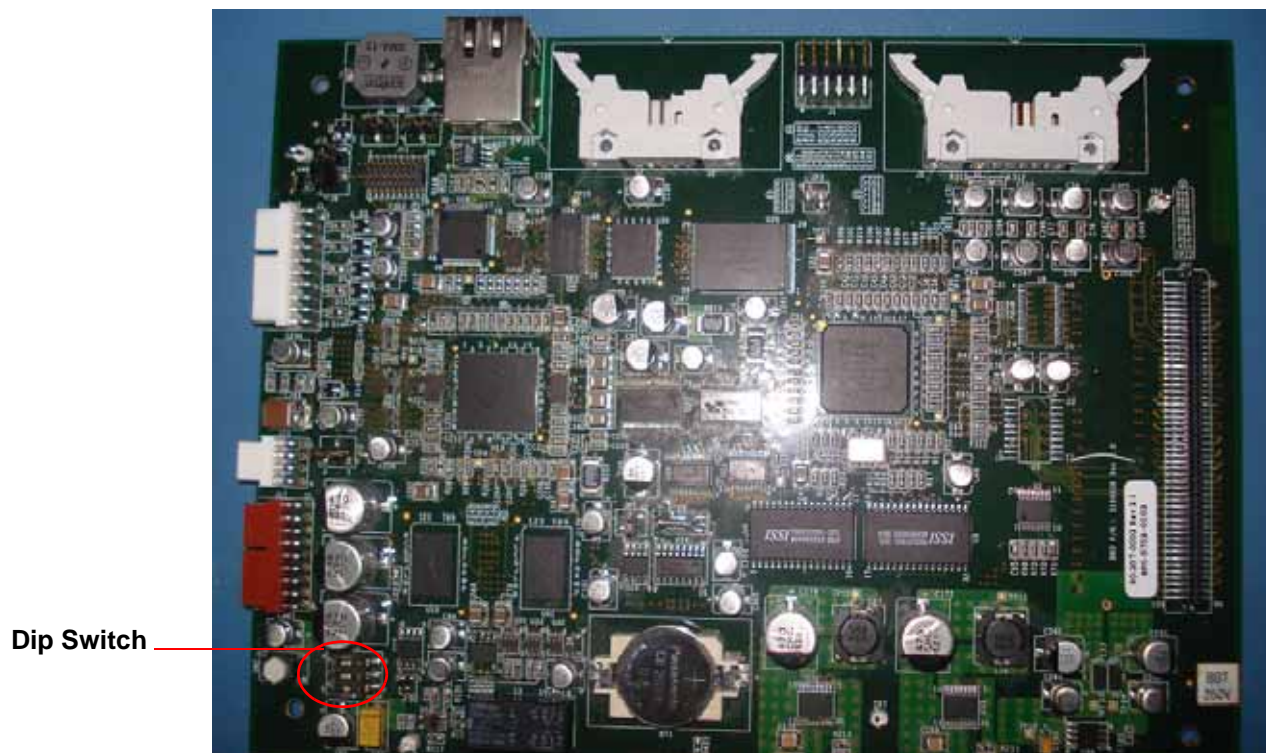

Figure 8-10 Davinci board Dip Switch Setting for NTSC & PAL

8-5-2 Disassembly/Assembly of FEB for LOGIQ™ 100 PRO

Follow steps and refer

- 1.) Remove Top Cover. Refer 8-2. For FRU Details refer 9-1-10
- 2.) Remove the screw fixing the FEB PCB to the Rear panel bracket.
- 3.) Remove four screws (a,b,c,d) from the probe connector.
- 4.) Remove one screw which is fixing FEB to the chassis in the front.
- 5.) Disconnect the two flat cables interfacing Davinci and Keyboard.
- 6.) Remove all cables connected to the FEB and Davinci board on the rear of the system.
- 7.) Hold the FEB and pull upward.
- 8.) Remove four screws fixed on the Davinci board to mate the Davinci and the FEB.
- 9.) Remove the Davinci board from the FEB Flush type connector slowly.
- 10.) For assembly follow the reverse order.

Service Manual Section	Functional Test/ Diagnostic Test	Debrief Script
4-2-1	Power ON/ Boot up	Service manual direction 5305880-100, Section 8-5-2. Equipment passed all required tests and is ready for use.
4-2-1	Power OFF/ Shut down	
4-3	Functional Checks	
4-5	Software configuration checks	
7-2-2	Diagnostics tests	

Table 8-8 Functional tests

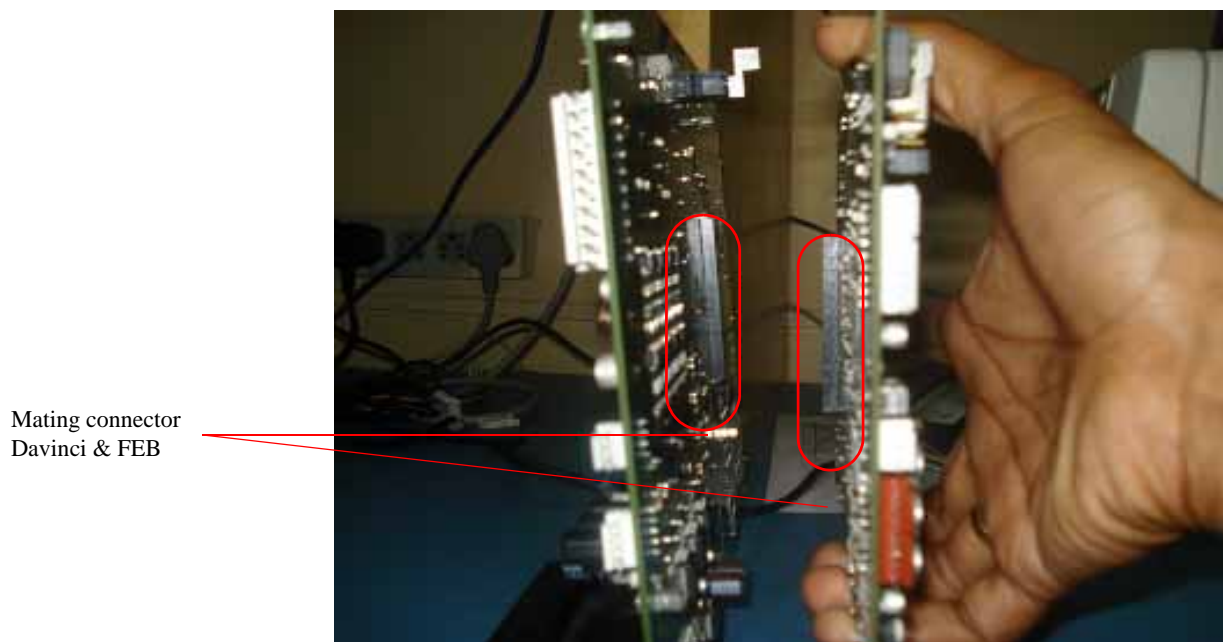

Figure 8-11 Disassembly/Assembly of FEB

Section 8-6 Fan Assembly

8-6-1 Disassembly/Assembly of Fan

Follow steps below and refer Figure 8-12. For FRU Details refer

- 1.) Remove Top Cover. Refer 8-2.
- 2.) Remove 2 screws (a,d) and loosen screws b,c from the chassis.
- 3.) Remove the connector (e) on the power distributor board which is connected to the fan.
- 4.) Remove Fan assembly from the unit.
- 5.) For assembly follow the reverse order.

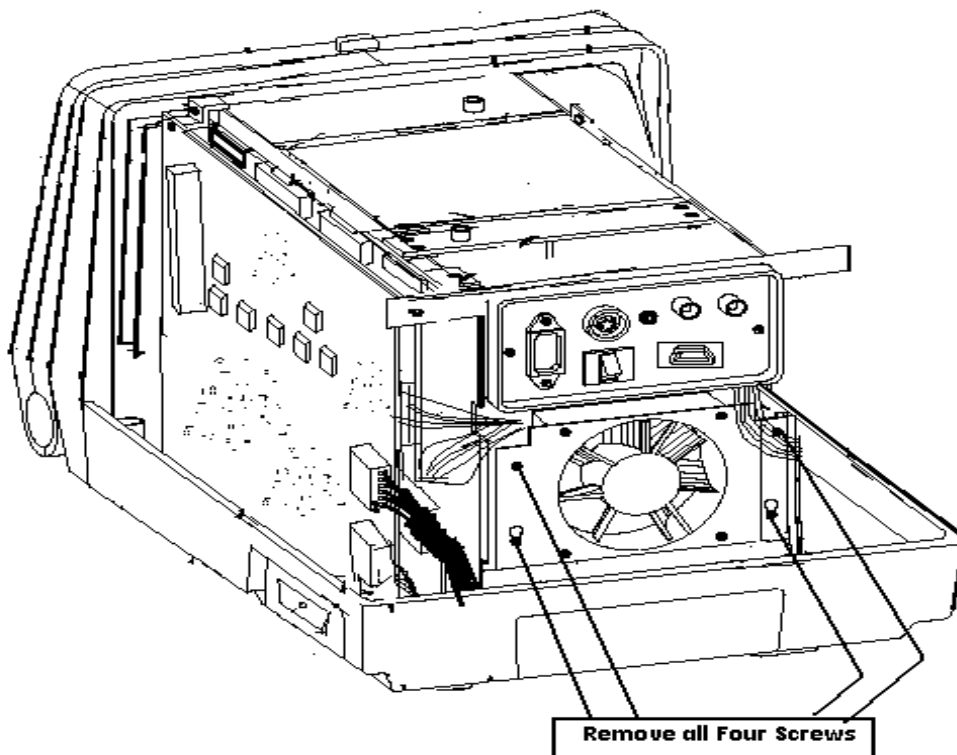

Figure 8-12 Disassembly/Assembly of Fan

Service Manual Section	Functional Test/ Diagnostic Test	Debrief Script
4-2-1	Power ON/ Boot up	Service manual direction 5305880-100, Section 8-6-1. Equipment passed all required tests and is ready for use.
4-2-1	Power OFF/ Shut down	
4-3	Functional Checks	

Table 8-9 Functional tests

Section 8-7 Power Supply/Distributor PCB

8-7-1 Disassembly/Assembly of Power Supply/Distributor PCB

Follow steps below and refer 8-13

- 1.) Remove Top Cover. Refer 8-2. For FRU Details refer
- 2.) Remove Front Panel. Refer 8-4-1
- 3.) Remove dust filter (m).
- 4.) Remove two screws (e,f) holding the power supply unit to the chassis.
- 5.) Remove four screws (c,d,g,h) to remove cross member.
- 6.) Remove the fan. Refer 8-6-1.
- 7.) Remove all connections on the Power Supply Distributor.
- 8.) Remove screws (a,b) holding the Power Supply to the chassis.
- 9.) Remove two screws (i,k) and loose the other two screws (j,l) and remove the dust filter plate.
- 10.) Slide the power supply forward (CRT may have to be lifted up to remove the power supply)
- 11.) Remove six screws holding the Power Supply Distributor PCB to the power supply rear bracket. (not shown in figure)
- 12.) Remove the Power Distributor PCB upward after disconnecting the cable connector between power supply and power distributor pcb.

13.) For assembly follow the reverse order.

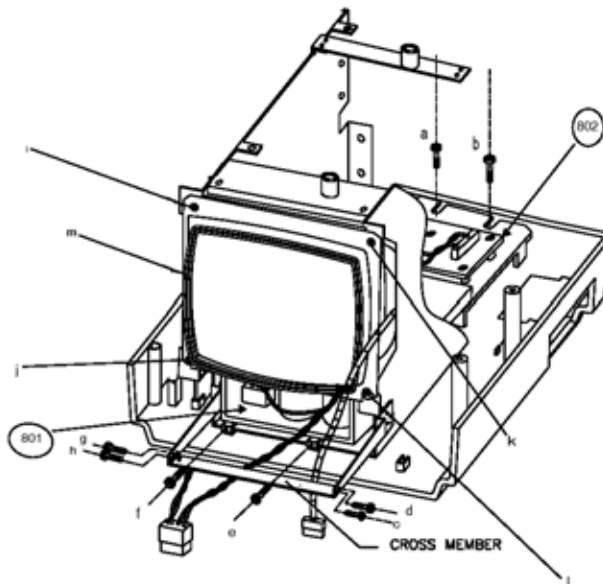

Figure 8-13 Disassembly/Assembly of Power Supply/Distributor PCB

Service Manual Section	Functional Test/ Diagnostic Test	Debrief Script
4-2-1	Power ON/ Boot up	Service manual direction 5305880-100, Section 8-7-1. Equipment passed all required tests and is ready for use.
4-2-1	Power OFF/ Shut down	
4-3	Functional Checks	
4-5	Software configuration check	
7-2	Diagnostics tests	

Table 8-10 Functional Tests

Section 8-8 Rear Panel

8-8-1 Disassembly/Assembly of Rear Panel

Follow steps below and refer 8-14

- 1.) Remove Top Cover. Refer 8-2. For FRU Details refer
- 2.) Remove Noise filter by removing screws (c,d) then disconnect the power cables from the noise filter.
- 3.) Remove all five screws indicated in the fig below from the rear panel.
- 4.) Remove the connectors from the Davinci board, FEB and CRT PCB.

- 5.) Remove the connections to the circuit breaker.
- 6.) Remove the rear panel from the chassis.
- 7.) For assembly follow the reverse order.

Table 8-11 Functional tests

Service Manual Section	Functional Test/ Diagnostic Test	Debrief Script
4-2-1	Power ON/ Boot up	Service manual direction 5305880-100, Section 8-8-1. Equipment passed all required tests and is ready for use.
4-2-1	Power OFF/ Shut down	
4-3	Functional Checks	
4-6	Peripheral checks	

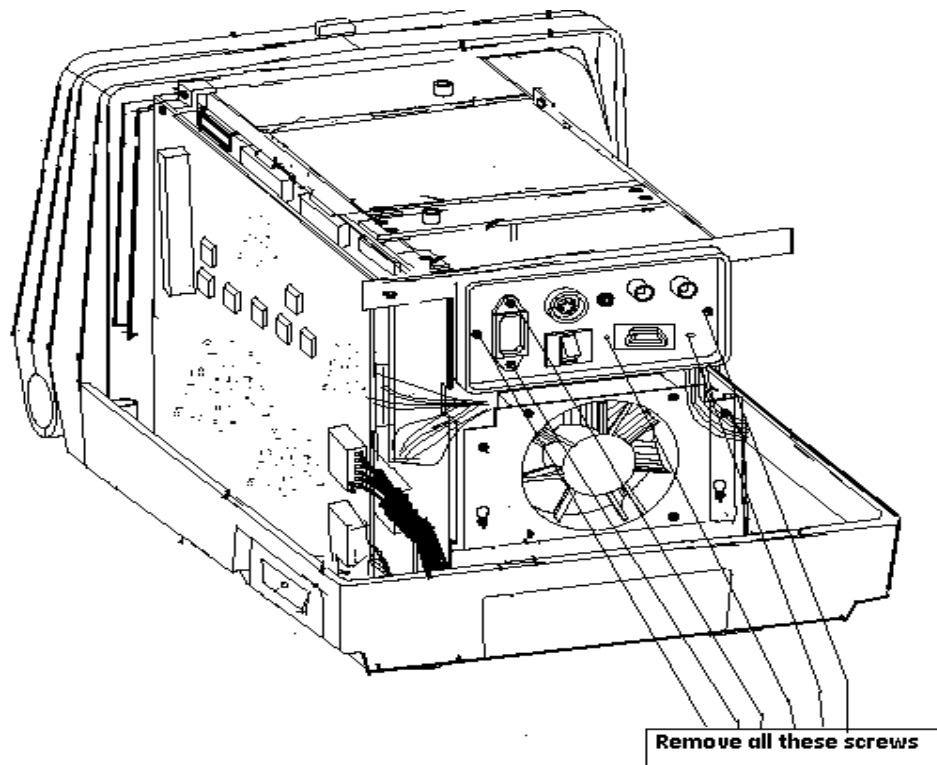

Figure 8-14 Disassembly/Assembly of Rear Panel

Section 8-9 HV Assembly

8-9-1 Disassembly/Assembly of HV Assembly

Follow steps below and refer 8-15

- 1.) Remove Top Cover. Refer.8-2. For FRU Details refer
- 2.) Remove the Shield Plate.
- 3.) Remove the cable to the HV Power Supply.
- 4.) Remove 2 screws on the clamp.
- 5.) Pull the HV PCB upward (cable has to be removed).
- 6.) For assembly follow the reverse order.

Table 8-12 Functional tests

Service Manual Section	Functional Test/ Diagnostic Test	Debrief Script
4-2-1	Power ON/ Boot up	Service manual direction 5305880-100, Section 8-9-1.Equipment passed all required tests and is ready for use.
4-2-1	Power OFF/ Shut down	
4-3	Functional Checks	

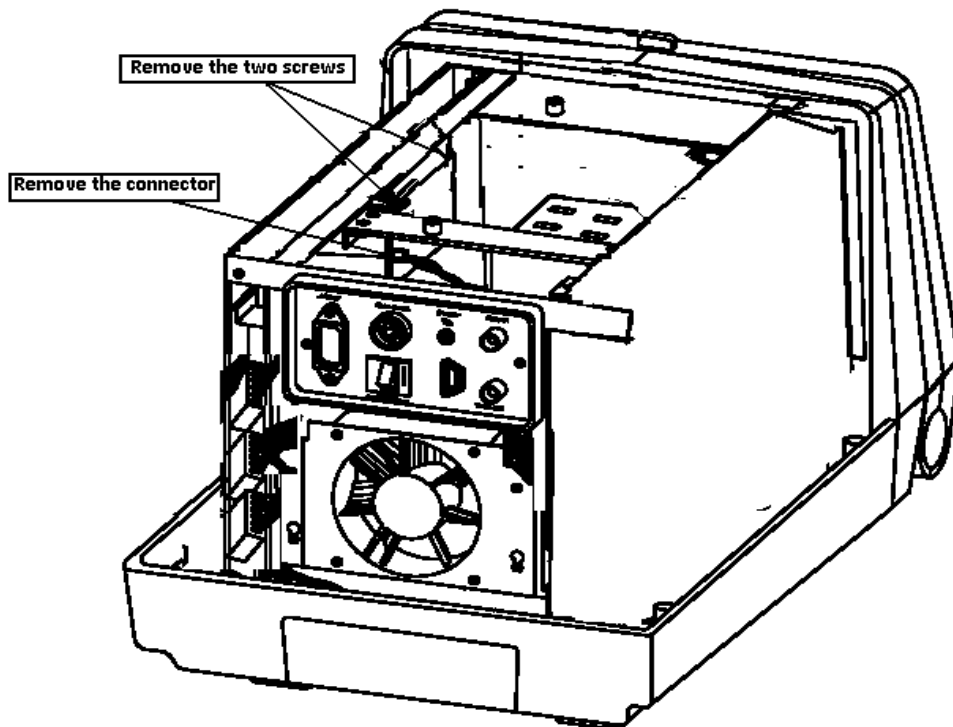

Figure 8-15 Disassembly/Assembly of HV Assembly
 Section 8-9 - HV Assembly

Section 8-10 Chassis

8-10-1 Disassembly/Assembly of Chassis.

Follow steps below and refer 8-16

1. Remove Top Cover. Refer 8-2. For FRU Details refer 9-1-12
2. Remove Front Panel. Refer 8-4-1
3. Remove Monitor Assembly. Refer 8-4-2
4. Remove PCBs. Refer 8-5
5. Remove the fan. Refer 8-6.
6. Remove the rear panel. Refer 8-8
7. Remove Power Supply. Refer 8-7-1
8. Remove HV Power Supply. Refer 8-9
9. Remove the chassis by removing eight screws (a,b,c,d,e,f,g,h) on the base.
10. For assembly follow the reverse order.

Table 8-13 Functional tests

Service Manual Section	Functional Test/ Diagnostic Test	Debrief Script
4-2-1	Power ON/ Boot up	Service manual direction 5305880-100, Section 8-10-1. Equipment passed all required tests and is ready for use.
4-2-1	Power OFF/ Shut down	
4-3	Functional Checks	
7-2	Diagnostics tests	
4-5	Software Configuration checks	
4-6	Peripheral checks	

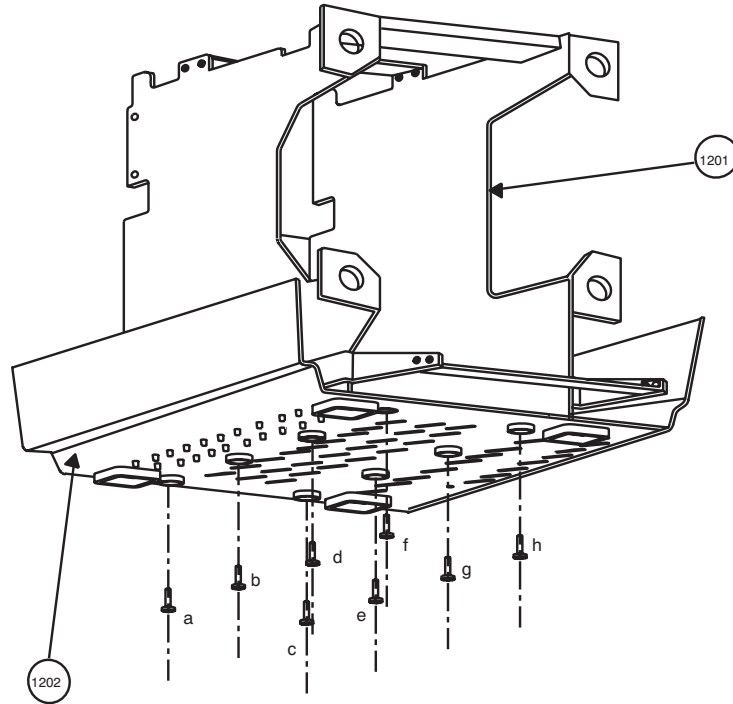

Figure 8-16 Disassembly/Assembly of Chassis

RELEASABLE COPY
SECTION 8-10

Chapter 9 Replacement Parts

Section 9-1 Overview

9-1-1 Purpose of Chapter 9

This chapter gives you an overview of Spare Parts for LOGIQ™ 100 PRO.

CONTENTS IN CHAPTER 9

Section	Description	Page Number
9-1	Overview	9-1
9-1-2	MATERIAL LIST - Top Cover	9-3
9-1-3	MATERIAL LIST - KEYBOARD	9-4
9-1-4	MATERIAL LIST - KEYBOARD ASSEMBLY	9-5
9-1-5	MATERIAL LIST - FRONT PANEL	9-7
9-1-6	MATERIAL LIST - Monitor	9-8
9-1-7	MATERIAL LIST - Davinci Board	9-9
9-1-8	MATERIAL LIST - FEB	9-10
9-1-9	9-1-9 MATERIAL LIST - Power Supply/Distributor PCB	9-11
9-1-10	9-1-10 MATERIAL LIST - Rear Panel	9-12
9-1-11	9-1-11 MATERIAL LIST - HV Power Supply Assembly	9-13
9-1-12	9-1-12 MATERIAL LIST - Cable Assembly	9-14

Table 9-1 Contents in chapter 9

MATERIAL LIST - LOGIQ™ 100 PRO

Part Name	Part No.	QTY.										Description
Operator Console Assembly	5304117	1										100-230VAC, 50/60Hz, PAL, GEMS-A.
	5304414		1									100-230VAC, 50/60Hz, PAL, GEMS-A/AM.
	5304240			1								100-230VAC, 50/60Hz, NTSC, GEMS-A/AM.
	5304248				1							100-230VAC, 50/60Hz, NTSC, GEMS-A/AM.
	5304441					1						100-230VAC, 50/60Hz, PAL, GEMS-E.
	5304596							1				110VAC, 50/60Hz, NTSC, GEMS-A.
	5306834								1			100-230VAC, 50/60Hz, PAL, GEMS-Russia
Power Cord (Indian Type)	2139759	1										100/230VAC, 50/60Hz
Power Cord (American Type)	2148714			1				1				100/115VAC, 50/60Hz
Power Cord (European Type)	2148713		1		1	1			1			100/230VAC, 50/60Hz
Probe Pad	2150887	6	6	6	6	6	6	6	6			
Aquasonic Gel	2139760	1	1	1	1	1	1	1	1			
Mini Plug Cable	P9509BC	1	1	1	1	1	1	1	1			
BNC Cable	P9509BD	1	1	1	1	1	1	1	1			
Foot Switch (Option)	2152089-2	1	1	1	1	1	1	1	1			H41062A
Mobile Trolley (option)	2196004	1	1	1	1	1	1	1	1			H41052LA
Modular Trolley (Option)	2240994	1	1	1	1	1	1	1	1			H41052LC
Two Probe Port (Option)	2208220	1	1	1	1	1	1	1	1			H41072A
E72 Probe Holder (Option)	2184039	1	1	1	1	1	1	1	1			H41042A
HP Laser jet Printers (Option)	5305335	1	1	1	1	1	1	1	1			HP Laser jet with USB Cable.
1020 only.												H41002LK
LOGIQ 200 Probe Adapter (Option)	2246444	1	1	1	1	1	1	1	1			H41192LA
H41072LA	INDIA											
H41072LB	CHINA, ANZ, SE-ASIA, MEXICO											
H41072LC	TAIWAN											
H41072LD	CHILE, KOREA											
H41072LE	EUROPE											
H41072LF	LA											
H41072LS												

RELEASED UNDER CRICOP SECTION 9-1



9-1-2 MATERIAL LIST - Top Cover

OPERATOR CONSOLE ASSY

5304117,5304414,5304240,5304248,5304441,5304596,5306834.

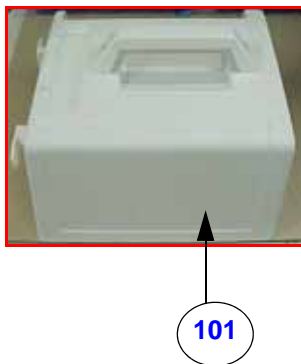

Figure 9-1 Top Cover

Table 9-1 Top Cover

Item	Part Name	Part No.	Description	Qty
101	Top Cover Assembly	5318780	LOGIQ™ 100 PRO	1

9-1-3 MATERIAL LIST - KEYBOARD

OPERATOR CONSOLE ASSY

5304117,5304414,5304240,5304248,5304441,5304596,5306834.

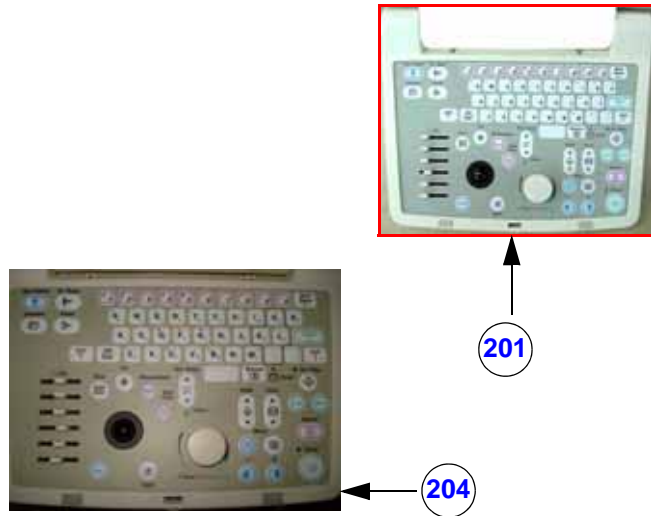

Figure 9-2 Keyboard

Table 9-2 Keyboard

Item	Part Name	Part No.	Description	Qty
201	Keyboard Assembly	5305699	LOGIQ™ 100 PRO	1
204	Keyboard assembly for L100 Pro_ Russia	5307742	LOGIQ™ 100 PRO	1

RELEASED UNDER E.O. 13526
 SECTION 1.4

9-1-4 MATERIAL LIST - KEYBOARD ASSEMBLY

OPERATOR CONSOLE ASSY

5304117,5304414,5304240,5304248,5304441,5304596,5306834.

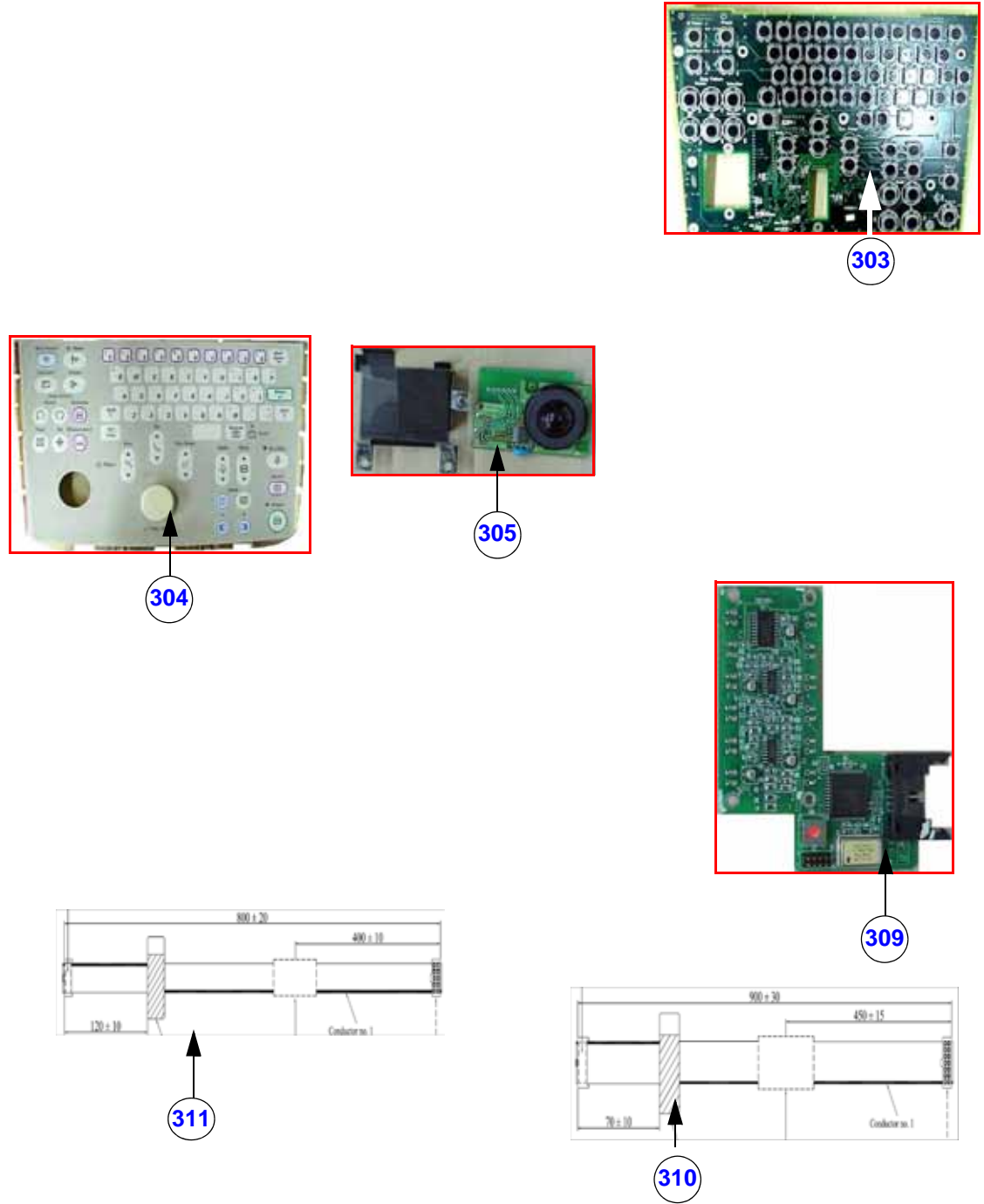

Figure 9-3 Keyboard Assy

Table 9-3 Keyboard Assembly

Item	Part Name	Part No.	Description	Qty
303	Keyboard PCB	5131077	LOGIQ™ 100 PRO	1
304	Keysheet With Base Plate	5135264	LOGIQ™ 100 PRO	1
305	Trackball Assembly	5133534	Includes bracket, screws, FPC cable & instruction. (Optical Trackball)	1
309	TGC Assembly	5304587	LOGIQ™ 100 PRO	1
310	Cable Assy 22N	5268899	Davinci keyboard interface cable	1
311	Cable Assy 26N	5264931	TGC - Davinci interface cable	1

UNCLASSIFIED//FOR OFFICIAL USE ONLY

9-1-5 MATERIAL LIST - FRONT PANEL

OPERATOR CONSOLE ASSY

5304117,5304414,5304240,5304248,5304441,5304596,5306834.

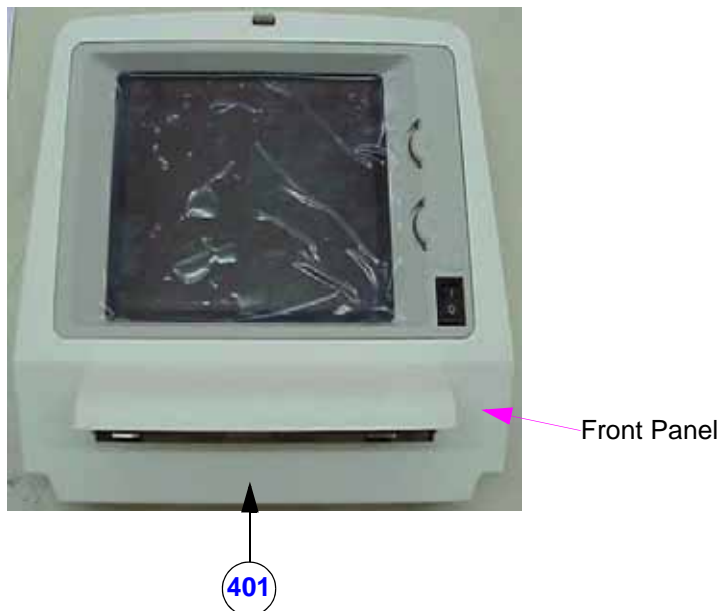

Figure 9-4 Front Panel

Table 9-4 Front Panel

Item	Part Name	Part No.	Description	Qty
401	Front Panel Assembly	2337067	LOGIQ™ 100 PRO	1

9-1-6 MATERIAL LIST - Monitor

OPERATOR CONSOLE ASSY

5304117,5304414,5304240,5304248,5304441,5304596,5306834.

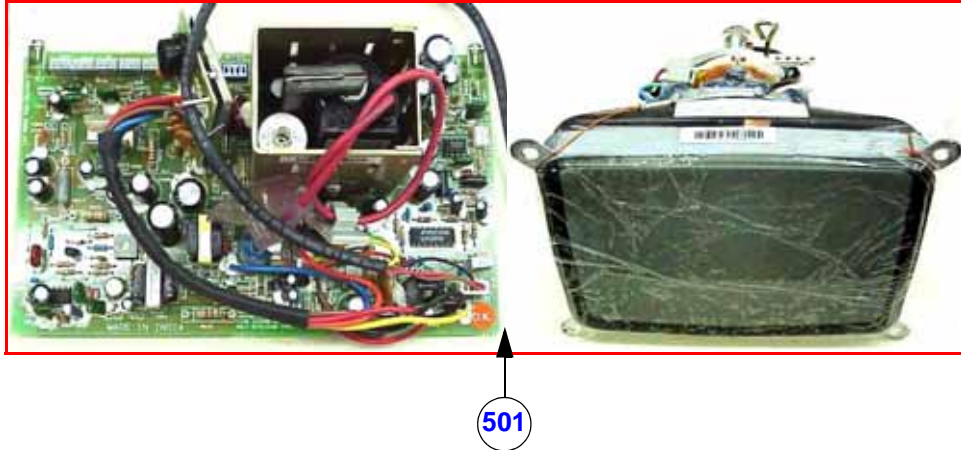

Figure 9-5 Monitor

Table 9-5 Monitor

Item	Part Name	Part No.	Description	Qty
501	Monitor Assembly (CRT+PCB) with Cable Assy 15 - PAL/NTSC	2139789-3	LOGIQ™ 100 PRO	1

UNCLASSIFIED//FOR OFFICIAL USE ONLY
 RELEASED UNDER E.O. 13526

9-1-7 MATERIAL LIST - DAVINCI

OPERATOR CONSOLE ASSY

5304117,5304414,5304240,5304248,5304441,5304596,5306834.

601
 ↓



Figure 9-6 Davinci Board

Table 9-6 Davinci

Item	Part Name	Part No.	Description	Qty
601	Davinci Assy (PAL/NTSC)	5212995	LOGIQ™ 100 PRO	1

- 1.) Davinci is common for PAL & NTSC, Only dip switch setting has to be changed for the required type.

9-1-8 Material List - FEB

OPERATOR CONSOLE ASSY

5304117,5304414,5304240,5304248,5304441,5304596,5306834.

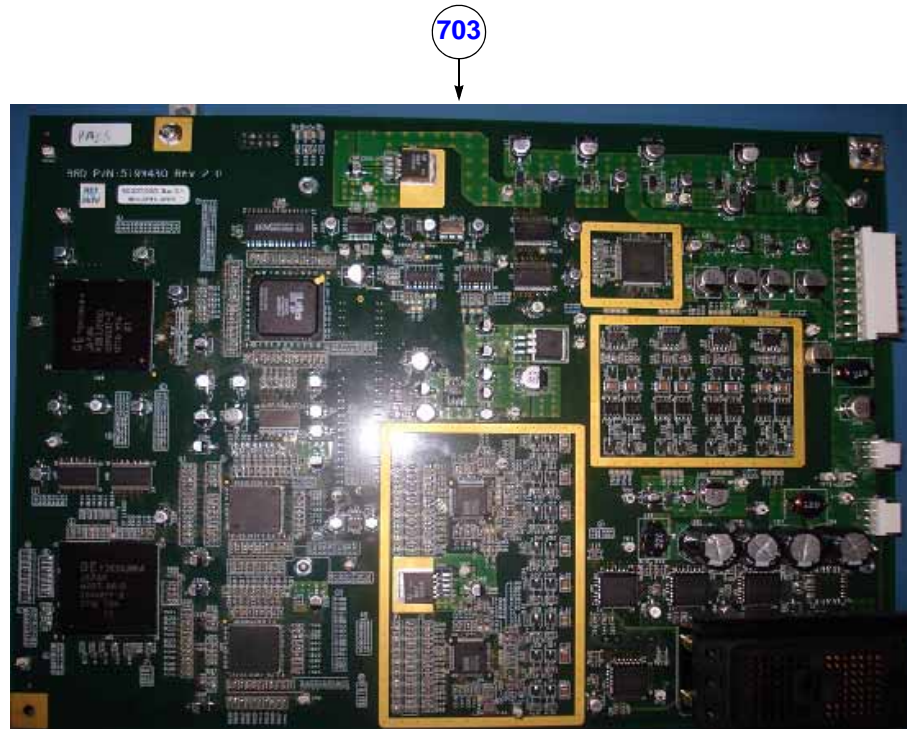

Figure 9-7 FEB Assembly

Table 9-7

Item	Part Name	Part No.	Description	Qty
703	FEB Assy	5199849	LOGIQ™ 100 PRO	1
704	FEB+DAVINCI Assy	5308177	LOGIQ™ 100 PRO	1

Davinci board

FEB



9-1-9 MATERIAL LIST - Power Supply/Distributor PCB

OPERATOR CONSOLE ASSY
 5304117,5304414,5304240,5304248,5304441,5304596,5306834.

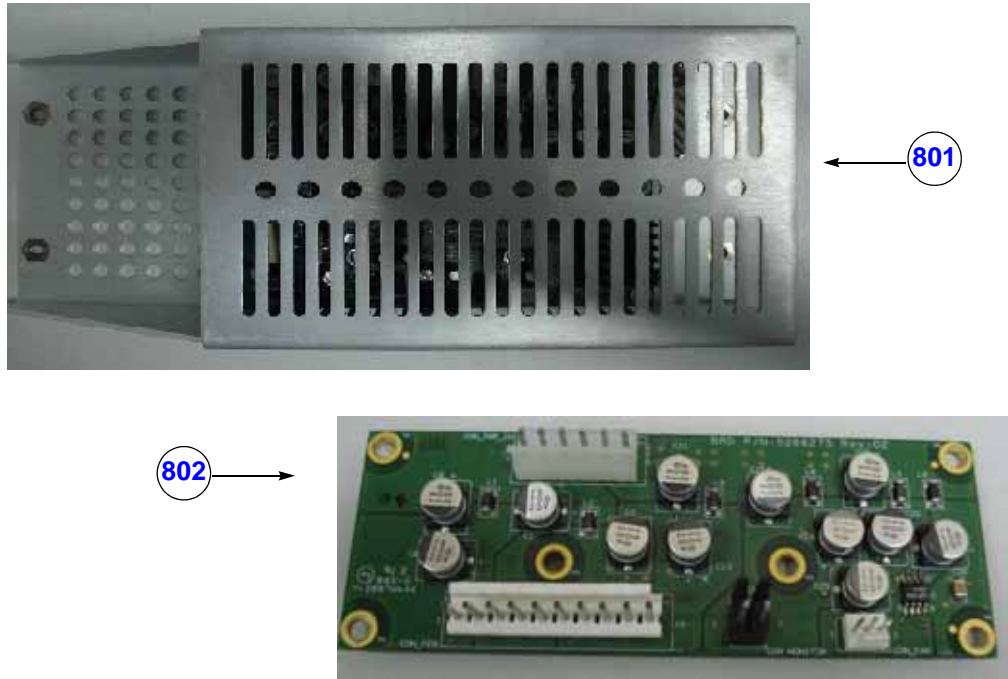

Figure 9-8 Power Supply/Distributor PCB

Table 9-8 Power Supply/Distributor PCB

Item	Part Name	Part No.	Description	Qty
801	Condor power supply assembly	5310660	LOGIQ™ 100 PRO	1
802	Power Distributor Assembly	5198818	LOGIQ™ 100 PRO	1

Note: Replace Cable Assy 28N (5267859) & Cable Assy 29N (5265017) when replacing Power Distributor PCB Assembly for the LOGIQ™ 100 PRO.

9-1-10 MATERIAL LIST - Rear Panel

OPERATOR CONSOLE ASSY

5304117,5304414,5304240,5304248,5304441,5304596,5306834.



Figure 9-9 Rear Panel Assembly

Table 9-9 Rear Panel Assy

Item	Part Name	Part No.	Description	Qty
901	Rear panel Assembly	5305191	LOGIQ™ 100 PRO	1
902	FAN Assembly	2139798	LOGIQ™ 100 PRO	1



RELEASED UNDER E.O. 13526
 SECTION 1.4

9-1-11 MATERIAL LIST - HV Power Supply Assembly

OPERATOR CONSOLE ASSY

5304117,5304414,5304240,5304248,5304441,5304596,5306834.



Figure 9-10 HV Power Supply Assembly

Table 9-10 HV Power Supply Assembly

Item	Part Name	Part No.	Description	Qty
1001	HV Power Supply Assembly	2300757	LOGIQ™ 100 PRO	1

9-1-12 MATERIAL LIST - Cable Assembly

OPERATOR CONSOLE ASSY

5304117,5304414,5304240,5304248,5304441,5304596,5306834.

FRU No.	PART NAME	PART NO.	QTY	FRU	DESCRIPTION
1301	LOGIQ™ 100 PRO Cable Set	5308178	1	1	For LOGIQ™ 100 PRO

Table 9-2 Cable Assembly for LOGIQ™ 100 PRO

LOGIQ™ 100 PRO Cable Set comprises of:

Part Name	Part Number	QTY.	Description
Cable Assy 3N	5268930	1	Cable used for interfacing mains power, low voltage power supply, noise filter and power switch Contains, apart from cable, Core Support Clamp and associated Screws and Nuts
USB Cable Assy	5269617	1	Davinci - Rear Panel USB Port cable for LOGIQ™ 100 PRO.
Cable Assy 28N	5267859	1	Power Distributor (PDB) to FEB
Cable Assy 29N	5265017	1	Power Supply to Power Distributor (PDB)
Cable Assy 30N	5273256	1	FEB to HV Power Supply

Table 9-3 Cable Set for LOGIQ™ 100 PRO.

List of PROBES

Probe Type	Part No.	Catalog No.
C36	2268634	H41252CF
C55	2107925	H45252CE
E72	2274908	H41252ME
L76	2274906	H41252HP
C31	2175994	H45252CS
*CZB	2152422	H45202CZ
*LB	P9601AQ	H46022LB

*To be used along with L200 probe Adapter.

Notes:

RELEASED UNDER
SECTION 552

Chapter 10 Quality Assurance

Section 10-1 Overview

10-1-1 Purpose of Chapter 10

This chapter describes Quality Assurance & Periodic Maintenance (PM) on the scanner and its peripherals. These PM procedures are intended to maintain the quality of the ultrasound systems performance. Read this chapter completely and familiarize yourself with the procedures before starting a PM.

CONTENTS IN CHAPTER 10

Section	Description	Page Number
10-1	Overview	10-1
10-2	Why do Periodic Maintenance	10-2
10-3	Periodic Maintenance Schedule	10-2
10-4	Tools Required	10-4
10-5	System Periodic Maintenance	10-7
10-6	Electrical Safety Tests	10-11
10-7	When There's Too Much Leakage Current...	10-23
	PM Inspection Certificate	10-29

Table 10-1 Contents in Chapter 10

Practice good ESD prevention. Wear an anti-static strap when handling electronic parts and even when disconnecting/connecting cables.

THERE ARE SEVERAL PLACES ON THE REAR PANEL THAT ARE DANGEROUS. BE SURE TO DISCONNECT THE SYSTEM POWER PLUG AND OPEN THE MAIN CIRCUIT BREAKER BEFORE YOU REMOVE ANY PARTS. BE CAUTIOUS WHENEVER POWER IS STILL ON AND COVERS ARE REMOVED.

Do not pull out or insert circuit boards while power is ON.

Do not operate this unit unless all board covers and frame panels are securely in place. System performance and cooling require this.

Section 10-2 Why do Periodic Maintenance

10-2-1 Keeping Records

It is good business practice that ultrasound facilities maintain records of periodic and corrective maintenance. The Ultrasound Periodic Maintenance Inspection Certificate provides the customer with documentation that the ultrasound scanner is maintained on a periodic basis.

A copy of the Ultrasound Periodic Maintenance Inspection Certificate should be kept in the same room or near the scanner.

10-2-2 Quality Assurance

In order to gain accreditation from organizations such as the American College of Radiology (USA), it is the customer's responsibility to have a quality assurance program in place for each scanner. The program must be directed by a medical physicist, the supervising radiologist/physician or appropriate designee.

Routine quality control testing must occur regularly. The same tests are performed during each period so that changes can be monitored over time and effective corrective action can be taken. Testing results, corrective action and the effects of corrective action must be documented and maintained on the site.

Your GE service representative can help you with establishing, performing and maintaining records for a quality assurance program.

Section 10-3 Periodic Maintenance Schedule

10-3-1 How often should PMs be performed?

The Periodic Maintenance Schedule specifies how often your LOGIQ™ 100 PRO should be serviced and what items need attention. It is the customer's responsibility to ensure the LOGIQ™ 100 PRO periodic maintenance is performed as scheduled in order to retain its high level of safety, dependability and performance.

Your GE Service Representative knows your LOGIQ™ 100 PRO best and can provide competent, efficient service. Please contact us for further information and to schedule GE Medical Systems Ultrasound to perform this service for you.

The services and intervals shown in the maintenance schedule assumes that you use your LOGIQ™ 100 PRO for an average patient load (10-12 per day).

If conditions exist which exceed typical usage and patient load, then it is recommended to increase the periodic maintenance frequencies.

Service at Indicated Time	Daily	Weekly	Monthly	Annually	Notes
Clean Probes	●*				* or before each use
Clean Probe Holders	●				
Inspect AC Mains Cable			●		Mobile Unit Check Weekly
Inspect Cables and Connectors			●		
Clean Console			●		
Clean Monitor and Touch Panel			●		
Check Control Panel Movement			●		Mobile Unit Check Daily
Console Leakage Current Checks				●	also after corrective maintenance or as required by your facilities QA program
Peripheral Leakage Current Checks				●	also after corrective maintenance or as required by your facilities QA program
Surface Probe Leakage Current Checks				●	also after corrective maintenance or as required by your facilities QA program
Endocavity Probe Leakage Current Checks					Twice Annually
Transesophageal Probe Leakage Current Checks					As Prescribed in probe manual
Surgical Probe Leakage Current Checks					As Prescribed in probe manual
Measurement Accuracy Checks				●	also after corrective maintenance or as required by your facilities QA program
Probe/Phantom Checks				●	also after corrective maintenance or as required by your facilities QA program

Table 10-2 Periodic Maintenance Schedule

Section 10-4 Tools Required

10-4-1 Standard GE Tool Kit

The following is a description of the "Standard" GE tool kit in the USA. Not all tools are required for PMs.

Tool ID	Description	Tool ID	Description
9-45358	Pliers Retaining Ring	9-XL9971MM	Xcelite-hex Blade 1.27mm
9-4078	Scribe	9-XL9972MM	Xcelite-hex Blade 1.5mm
9-44572	Wrench Open End 3/8 - 7/16	9-XL9973MM	Xcelite-hex Blade 2 mm
9-44579	Wrench Open End 1/2 - 9/16	9-XL9974MM	Xcelite-hex Blade 2.5mm
9-44579	Wrench Open End 1/2 - 9/16	9-XL9975MM	Xcelite-hex Blade 3mm
9-45385	Pliers, Arc Joint 7 inch	9-XL9976MM	Xcelite-hex Blade 4mm
9-45378	Pliers, Slip Joint	9-XL9977MM	Xcelite-hex Blade 5mm
9-4518	Pliers, Long Nose, Miniature	9-XL991CM	Handle
9-4518	Pliers, Long Nose, Miniature	C2356E	Screw starter - Kedman Quick Wedge
9-44776	Ignition Wrench Set, 10 pc.	BLBO	Box - 18 Compartment
9-44601	Wrench, Adj., 4 inch	DWL4283T	Box - 5 Compartment
9-4151	Screwdriver, Blade, Stubby	9-41322	Pickup Tool, Claw type
9-41421	Screwdriver, Blade, Pocket clip	9-6757	6 pc Needle File Set
9-41594	Screwdriver, Blade 1/8 in. x 4 in.	9-9487	Utility Knife
9-41581	Screwdriver, Blade 3/16 in. x 4 in.	9-45341	Pliers Vice Grip 10 inch
9-39451	20' Steel Tape, locking Spring load	9-3001	Xacto Pen Knife
9-GH807	Ratchet, Offset, Slotted	9-HT62002	Solder Aid, Fork and Hook
68-412	Ratchet, Offset, Phillips	9-4099	Mirror, Round, Telescoping
9-GH130	Tapered Reamer	9-GH3001	Steel Rule Decimal 6 inch
9-41584	Screwdriver, slotted 1/4 in.X 6 in.	9-GH300ME	Steel Rule Metric 6 inch
9-4118	Screwdriver, Phillips #2, Stubby	9-XL9920	Xcelite-hex Blade.050 inch
9-41293	Screwdriver, Phillips #0	9-XL9921	Xcelite-hex Blade 1/16 inch
9-41294	Screwdriver, Phillips #1	9-XL9922	Xcelite-hex Blade 5/16 inch
9-41295	Screwdriver, Phillips #2	9-XL9923	Xcelite-hex Blade 3/32 inch
9-46677	Hex Keys, 20 pc., Metric	9-XL9924	Xcelite-hex Blade 1/8 inch
9-34701	1/4 in. Standard.Socket set (19 pc)	9-XL9925	Xcelite-hex Blade 5/32 inch
9-43499	1/2 inch Socket 1/4 inch drive	9-XL9926	Xcelite-hex Blade 3/16 inch

Table 10-3 Overview of GE-1 Tool Kit Contents

Tool ID	Description	Tool ID	Description
9-4355	Flex Spinner	9-XL99764	Xcelite-hex Blade 7/64
9-43523	Breaker	9-XL99964	Xcelite-hex Blade 9/64
9-43531	6 inch Ext.	9-XLM60	Mini-screwdriver kit
9-65283	Case 8.5 in. x 4.5 in. x 2 in. Deep	9-45072	Pliers 6 inch Diagonal
9-46696	Hex Keys	9-XL100X	Wire Stripper/Cutter 5 inch - 100X
9-39829	Torpedo Level, Magnetic	9-XL87CG	Pliers - very fine needle nose-87CG
9-38461	Hammer, Ball Peen, 4 oz	9-WEWDT-07	Weller-Soldering-Replacement Tip(1)
9-4280	Universal Joint 1/4 inch	9-WS175-E	Wiss - Surgical Scissors
9-WEW60P3	Weller - Soldering Iron, 3 wire	KH174	Hemostat 5 inch Straight
9-WECT5B6	Weller - Soldering Iron Tip	KH175	Hemostat 5 inch curved
9-WEWDP12	Weller - Desoldering Pump	9-Z9480121	Alignment tool (red)
93383	Flashlight Mini-Mag Lite (AAA Bat.)		
9-GH408	Tweezers		
21576	Brush - Bristle		
9-4516	Pliers 4 1/4 inch Diagonal		

Table 10-3 Overview of GE-1 Tool Kit Contents (Continued)

GE-2 Sears Kit (#99034)			
Tool ID	Description	Tool ID	Description
9-45381	Pliers, Arc Joint 9 1/2 inch	9-44067	Socket 1 1/16 in. for 1/2 in. drive
9-45092	Pliers, Linesman 8 1/2 inch	9-42679	Socket 10MM Hex for 1/2 in. drive (2273333)
9-42882	Punch, Pin 3/32 inch	9-44262	Extension 10 inch for 1/2 in. drive (2273405)
9-42884	Punch, Pin 5/32 inch	9-4258	3/8 inch to 1/2 inch Adapter
9-42886	Punch, Pin 1/4 inch	9-34374	3/8 inch Metric Socket Set - 12 PT
9-42973	Cold Chisel 1/2 inch	9-44311	16mm Socket 12 pt.
9-GH77	Center Punch Automatic	9-33485	Metal Socket Tray
9-GH890	File Handle, Adj.	9-33484	Metal Socket Tray
9-31276	File, Round, Bastard 8 inch	9-33484	Metal Socket Tray
9-31277	File, Half Round, Bastard 8 inch	9-52068	Tap and Drill Set
9-31263	File, Flat Mill 8 inch	9-52722	#6 Tap

Table 10-4 Overview of GE-2 Tool Kit Contents

GE-2 Sears Kit (#99034)			
Tool ID	Description	Tool ID	Description
21045C	Close Quarter Saw	9-52723	#8 Tap
9-44604	Wrench, Adj 10 inch		High Speed Drill Set
9-41587	Screwdriver 5/16 inch x 8 inch		#36 Drill
9-41586	Screwdriver, Stubby 5/16 inch		#29 Drill
9-GH19512	Countersink 1/2 inch	9-44046	3/8 inch Socket Set
9-44741	12 PC Combination Wrench Set		

Table 10-4 Overview of GE-2 Tool Kit Contents (Continued)

10-4-2 Special Tools, Supplies and Equipment

10-4-2-1 Specific Requirements for Periodic Maintenance

See Chapter 7

Tool	Part Number	Comments
Digital Volt Meter (DVM)		
Electric Safety Analyzer DALE 600	46-285652G1	For 120V Unit
Electric Safety Analyzer DALE 600E	46-328406G2	For 220V Units
Leakage Current Ultrasound Kit	2113015	For 120V and 220V Units
Anti Static Kit	46-194427P231 46-194427P279 46-194427P369 46-194427P373 46-194427P370	Kit includes anti-static mat, wrist strap and cables for 200 to 240 V system 3M #2204 Large adjustable wrist strap 3M #2214 Small adjustable wrist strap 3M #3051 conductive ground cord
Anti Static Vacuum Cleaner	46-194427P278 46-194427P279	120V 230V
Safety Analyzer	46-285652G1	DALE 600 KIT (or equivalent) for electrical tests
SVHS VCR Cassette	E7010GG E7010GF	60 minute 120 minute
SVHS VCR Head Cleaner		See VCR user manual for requirements
B/W Printer Cleaning Sheet		See printer user manual for requirements
Disposable Gloves		

Table 10-5 Overview of Requirements for Periodic Maintenance

Section 10-5 System Periodic Maintenance

10-5-1 Preliminary Checks

The preliminary checks take about 15 minutes to perform. Refer to the system user documentation whenever necessary.

Step	Item	Description
1	Ask & Listen	Ask the customer if they have any problems or questions about the equipment.
2	Paperwork	Fill in the top of the Periodic Maintenance (PM) Inspection Certificate. Note all probes and system options.
3	Power up	Turn the system power on and verify that all fans and peripherals turn on. Watch the displays during power up to verify that no warning or error messages are displayed.
4	Probes	Verify that the system properly recognizes all probes.
5	Displays	Verify proper display on the monitor.
6	Presets	Take printout of all customer presets as a backup.

Table 10-6 System Preliminary Checks

10-5-2 Functional Checks (See Also Chapter 4)

The functional checks take about 30 minutes to perform. Refer to the system user documentation whenever necessary.

10-5-2-1 System Checks

Step	Description
B-Mode	Verify basic B-Mode (2D) operation. Check the basic system controls that affect this mode of operation.
M-Mode	Verify basic M-Mode operation. Check the basic system controls that affect this mode of operation.
System Diagnostic	Perform the Automatic Tests, <i>see section 7-2 on page 7-3</i> , to verify that all boards function according to specifications.
Control Panel Test	Perform the Control Panel Test Procedure, <i>see section 7-2-3 on page 7-9</i> , to verify that all keyboard controls are OK. This is performed by the internal PC (backend processor) which does a normal keyboard run through.
Monitor	Verify basic Monitor display functions. Refer to Chapter 3 of the User Manual.
Measurements	Use the measurement controls to verify distance and area calculation accuracy. Refer to the User Manual, Chapter 18, for measurement accuracy specifications.

Table 10-7 System Functional Checks

10-5-2-2 Peripheral/Option Checks

If any peripherals or options are not part of the system configuration, the check can be omitted. Refer to the User Manual for a list of approved peripherals/options.

Step	Item	Description
1	VCR	Verify record/playback capabilities of the VCR. Clean heads and covers if necessary.
2	VGP Printer	Verify hardcopy output of the video graphic printer. Clean heads and covers if necessary.
3	B/W Printer	Verify hardcopy output of the B/W printer. Clean heads and covers if necessary.
4	Footswitch	Verify that the footswitch is functioning as programmed. Clean as necessary.

Table 10-8 GE Approved Peripheral/Hardware Option Functional Checks

10-5-3 Input Power

10-5-3-1 Mains Cable Inspection

Step	Item	Description
1	Unplug Cord	Disconnect the mains cable from the wall and system.
2	Inspect	Inspect it and its connectors for damage of any kinds.
3	Verify	Verify that the LINE, NEUTRAL and GROUND wires are properly attached to the terminals, and that no strands may cause a short circuit.
4	Verify	Inlet connector retainer is functional.

Table 10-9 Mains Cable Inspection

10-5-4 Cleaning

10-5-4-1 General Cleaning

Step	Item	Description
1	Console	Use a fluid detergent in warm water on a soft, damp cloth to carefully wipe the entire system. Be careful not to get the cloth too wet so that moisture does not enter the console.
2	Probe Holder	Clean probe holders. (they may need to be soaked to remove excess gel).

Table 10-10 General Cleaning

10-5-5 Physical Inspection

Step	Item	Description
1	Labeling	Verify that all system labeling is present and in readable condition.
2	Scratches & Dents	Inspect the console for dents, scratches or cracks.
3	Control Panel	Inspect keyboard and control panel. Note any damaged or missing items.
4	Control Panel Movement	Verify ease of control panel (Operator I/O Panel) movement in all acceptable directions. Ensure that it latches in position as required.
5	Cables & Connectors	Check all internal cable harnesses and connectors for wear and secure connector seating. Pay special attention to footswitch assembly and probe strain or bend reliefs.
6	Shielding & Covers	Check to ensure that all EMI shielding, internal covers, air flow panels and screws are in place. Missing covers and hardware could cause EMI/RFI problems while scanning.
7	External I/O	Check all connectors for damage and verify that the labeling is good.

Table 10-11 Physical Checks

10-5-6 Probe Maintenance

10-5-6-1 Probe Related Checks

Step	Item	Description
1	Probe Holder	Clean probe holders. (they may need to be soaked to remove excess gel).
2	Probes	Thoroughly check the system probe connectors and remove dust from inside the connector sockets if necessary. Visually check for bent, damaged or missing pins

Table 10-12 Probe Related Checks

10-5-6-2 Basic Probe Care

The system user manuals and various probe handling cards provide a complete description of probe care, maintenance, cleaning and disinfection. Ensure that you are completely familiar with the proper care of GE probes.

Ultrasound probes can be easily damaged by improper handling. See the User Manual and probe care cards for more details. Failure to follow these precautions can result in serious injury and equipment damage. Failure to properly handle or maintain a probe may also void its warranty.

Any evidence of wear indicates the probe cannot be used.

Do a visual check of the probe pins and system sockets before plugging in a probe.

TEE and Interoperative probes often have special considerations and individual probe user manuals. For TEE and Interoperative probes also refer to their separate user manuals.

10-5-6-3 Basic Probe Cleaning

Refer to the User's Manual for details on probe cleaning.

To help protect yourself from blood borne diseases, wear approved disposable gloves. These are made of nitrile derived from vegetable starch to prevent allergic latex reactions.

Failure to follow the prescribed cleaning or disinfection procedures will void the probe's warranty. DO NOT soak or wipe the lens with any product not listed in the User Manual. Doing so could result in irreparable damage to the probe. Follow care instructions that came with the probe. Disinfect a defective probe before you return it. Be sure to tag the probe as being disinfected.

Section 10-6 Electrical Safety Tests

10-6-1 Safety Test Overview

The electrical safety tests in this section are based on and conform to NFPA 99 (For USA) and IEC 60601-1 Medical Equipment Safety Standards. They are intended for the electrical safety evaluation of cord-connected, electrically operated, patient care equipment. If additional information is needed, refer to the NFPA 99 (For USA) and IEC 60601-1 documents.

THE USER MUST ENSURE THAT THE SAFETY INSPECTIONS ARE PERFORMED AT LEAST EVERY 12 MONTHS ACCORDING TO THE REQUIREMENTS OF THE PATIENT SAFETY STANDARD IEC-EN 60601-1. ONLY TRAINED PERSONS ARE ALLOWED TO PERFORM THE SAFETY INSPECTIONS MENTIONED ABOVE.

To avoid electrical shock, the unit under test must not be connected to other electrical equipment. Remove all interconnecting cables and wires. The unit under test must not be contacted by users or patients while performing these tests.

Possible risk of infection. Do not handle soiled or contaminated probes and other components that have been in patient contact. Follow appropriate cleaning and disinfecting procedures before handling the equipment.

Test the system, peripherals and probes for leakage current. Excessive leakage current can cause injury or death in sensitive patients. High leakage current can also indicate degradation of insulation and a potential for electrical failure. Do not use probes or equipment having excessive leakage current.

To minimize the risk that a probe may shock someone the customer should:

- Not use a probe that is cracked or damaged in any way
- Check probe leakage current:
 - * once a year on surface probes
 - * twice a year on endocavitary probes
 - * whenever probe damage is suspected

10-6-2 GEMS Leakage Current Limits

The following limits are summarized for NFPA 99 (For USA) and IEC 60601-1 Medical Equipment Safety Standards. These limits are GEMS standards and in some cases are lower than the above standards listed.

Country	Normal Condition	Open Ground	Reverse Polarity	Open Neutral
USA	N/A	0.3 mA	0.3 mA	N/A
Other	0.1 mA	0.5 mA	0.5 mA	0.5 mA

Table 10-13 Chassis Leakage Current Limits—Accessible Metal Surfaces

Country	Normal Condition	Open Ground	Reverse Polarity	Open Neutral	*Mains Applied
USA	0.05 mA	0.05 mA	0.05 mA	0.05 mA	N/A
Other	0.1 mA	0.5 mA	0.5 mA	0.5 mA	5.0 mA

Table 10-14 Type BF Applied Part Leakage Current Limits - Non-Conductive (Floating) Surface and Cavity Probes

Country	Normal Condition	Open Ground	Reverse Polarity	Open Neutral	*Mains Applied
USA	0.01 mA	0.05mA	0.05 mA	N/A	0.025 mA
Other	0.01 mA	0.05 mA	0.05 mA	0.05 mA	0.05 mA

Table 10-15 Type CF Applied Part Leakage Current Limits - Surgical Probes and ECG Connections

**Mains Applied refers to the sink leakage test where mains (supply) voltage is applied to the part to determine the amount of current that will pass (or sink) to ground if a patient contacted mains voltage.*

The following tests are performed at the factory and should be performed at the site. These tests are: grounding continuity, chassis leakage current, probe leakage current, and ECG leakage current. All measurements are made with an electrical safety analyzer Model 600/600E built by Dale Technology Corporation or equivalent device.

10-6-3 Outlet Test - Wiring Arrangement - USA & Canada

Test all outlets in the area for proper grounding and wiring arrangement by plugging in the neon outlet tester and noting the combination of lights that are illuminated. Any problems found should be reported to the hospital immediately and the receptacle should not be used.

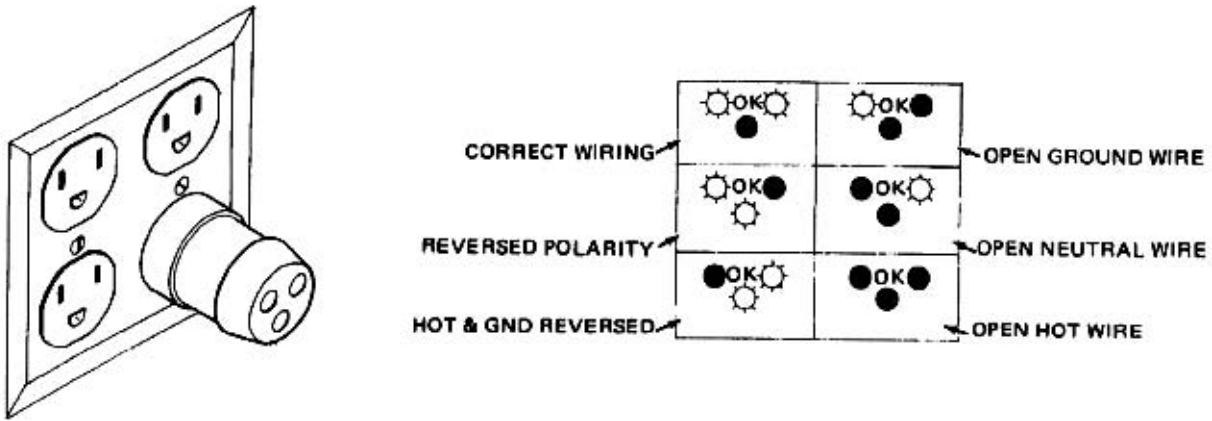

Figure 10-1 Typical Alternate Outlet Tester

The Dale 600 has self-contained lamps designed for testing the outlet wiring arrangement. Plug the Dale 600 into each outlet to be tested comparing the lamp status.

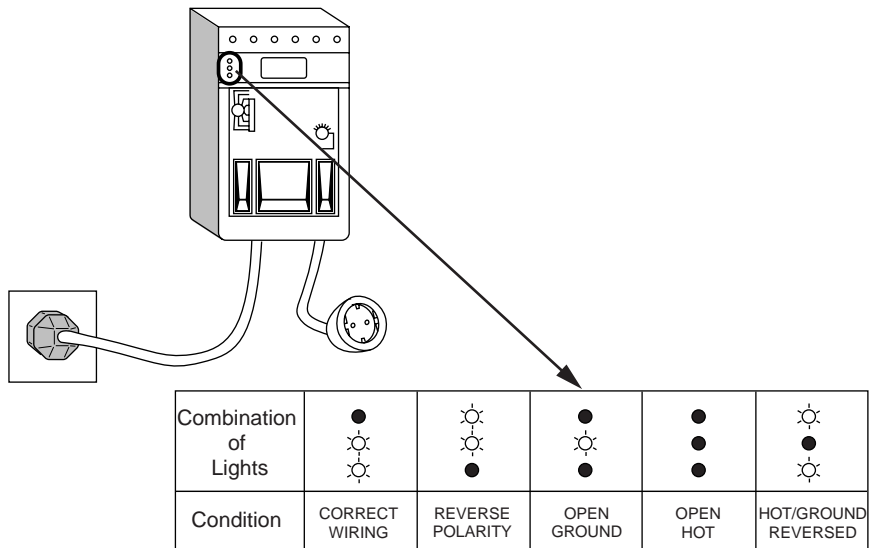

Figure 10-2 Dale 600 Outlet Test

Note: No outlet tester can detect the condition where the Neutral (grounded supply) conductor and the Grounding (protective earth) conductor are reversed. If later tests indicate high leakage currents, this should be suspected as a possible cause and the outlet wiring should be visually inspected.

10-6-4 Grounding Continuity

Electric Shock Hazard. The patient must not be contacted to the equipment during this test

Measure the resistance from the third pin of the attachment plug to the exposed metal parts of the case. The ground wire resistance should be less than **0.2** ohms. Reference the procedure in the IEC 601-1.1.

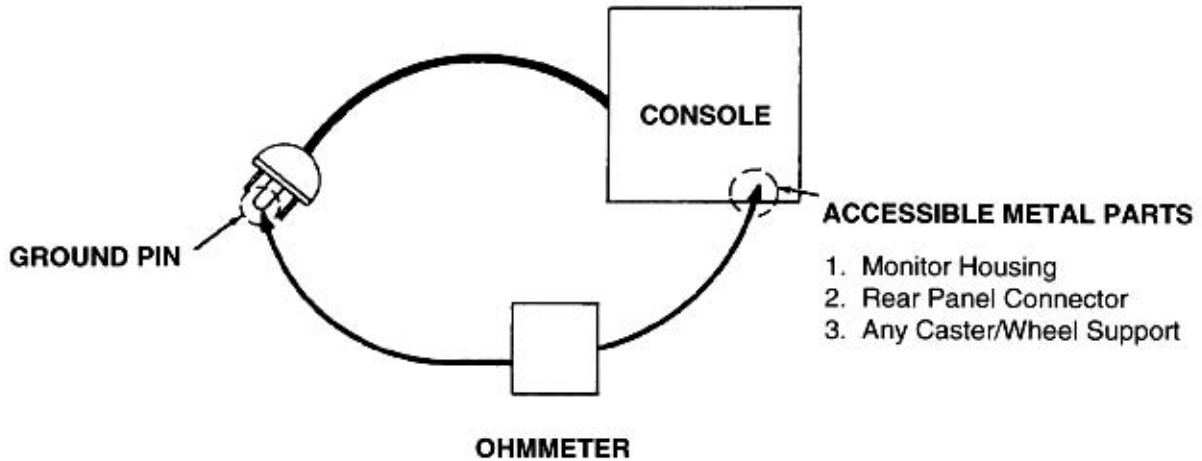

Figure 10-3 Ground Continuity Test

10-6-4-1 Meter Procedure

Follow these steps to test the ground wire resistance.

- 1.) Turn the LOGIQ™ 100 PRO unit OFF.
- 2.) Plug the unit into the meter, and the meter into the tested AC wall outlet.
- 3.) Plug the black chassis cable into the meter's "CHASSIS" connector and attach the black chassis cable clamp to an exposed metal part of the LOGIQ™ 100 PRO unit.
- 4.) Set the meter's "FUNCTION" switch to the RESISTANCE position.
- 5.) Set the meter's "POLARITY" switch to the OFF (center) position.
- 6.) Measure and record the ground wire resistance.

10-6-5 Chassis Leakage Current Test

10-6-5-1 Definition

This test measures the current that would flow in a grounded person who touched accessible metal parts of the bedside station if the ground wire should break. The test verifies the isolation of the power line from the chassis. The meter is connected from accessible metal parts of the case to ground. Measurements should be made with the unit On and Off, with the power line polarity Normal and Reversed. Record the highest reading.

Electric Shock Hazard. When the meter's ground switch is OPEN, don't touch the unit!

Equipment damage possibility. Never switch the Polarity and the status of Neutral when the unit is powered ON. Be sure to turn the unit power OFF before switching them using the POLARITY switch and/or the NEUTRAL switch. Otherwise, the unit may be damaged.

10-6-5-2 Generic Procedure

The test verifies the isolation of the power line from the chassis. The testing meter is connected from accessible metal parts of the case to ground. Measurements should be made with the unit ON and OFF, with the power line polarity Normal and Reversed. Record the highest reading of current.

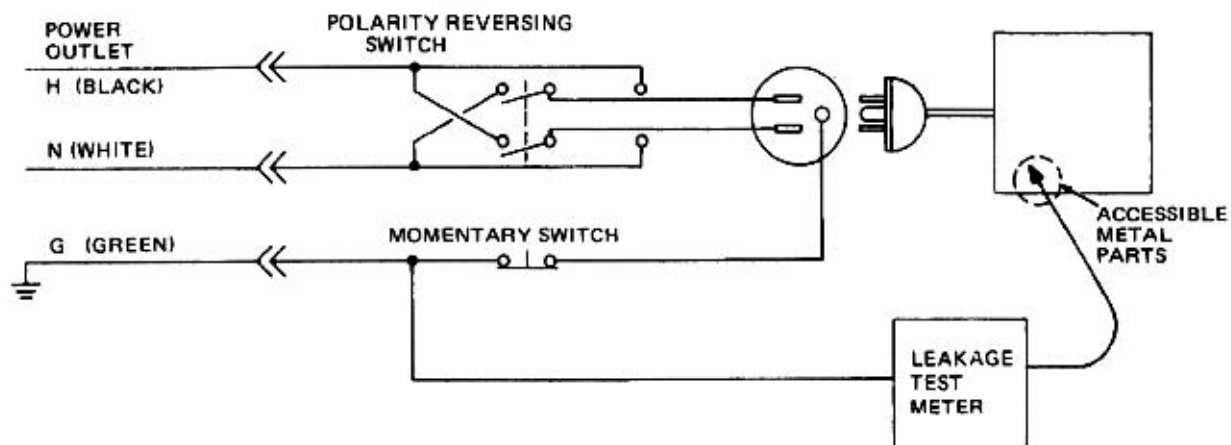

Figure 10-4 Set Up for Chassis Source Leakage Current, IEC 601-1 Clause 19 - Continuous Leakage Currents and Patient, Auxiliary Currents

When using the Microguard or a similar test instrument, its power plug may be inserted into the wall outlet and the equipment under test is plugged into the receptacle on the panel of the meter. This places the meter in the grounding conductor and the current flowing from the case to ground will be indicated in any of the current ranges. The maximum allowable limit for chassis source leakage is shown in Table 10-13.

10-6-5-3 Dale 600 Meter Procedure

When measuring system chassis currents with the Dale 600, always use the CHASSIS selection of the external/chassis function switch. This requires the ground clip lead and changing the meters switches in accordance with the IEC 601-1.1. Refer to the Dale 600 Instruction Manual for meter self-test and operation. Record the highest leakage current measured. Follow these steps to test the unit for leakage current.

- 1.) Turn the LOGIQ™ 100 PRO unit OFF.
- 2.) Plug the unit into the meter, and the meter into the tested AC wall outlet
- 3.) Plug the black chassis cable into the meter's "CHASSIS" connector and attach the black chassis cable clamp to an exposed metal part of the LOGIQ™ 100 PRO.
- 4.) Set the tester's "FUNCTION" switch to CHASSIS position.

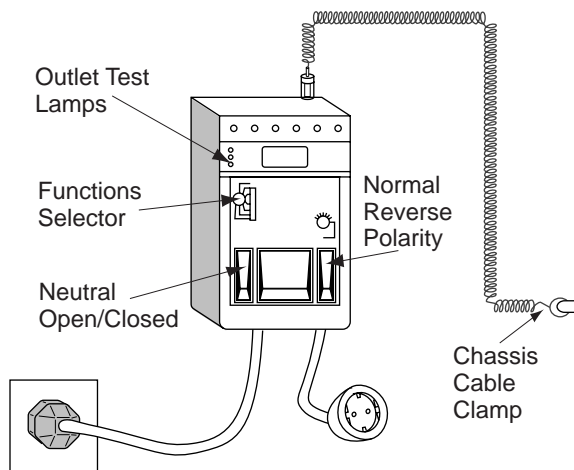

Figure 10-5 Ground and Chassis Leakage Current Test

- 5.) Follow the test conditions described for respective test points shown in Table 10-16.

TEST	CONDITION
1	Mounting screw for probe receptacle
2	Wheel support
3	Mounting screw for peripheral plugged into unit
4	Mounting screw for other peripheral powered by unit

Table 10-16 Chassis Leakage Current Test Condition

- 6.) Keep a record of the results with other hard copies of PM data kept on site.

10-6-5-4 Data Sheet for Chassis Source Leakage Current

The test passes when all readings measure less than the value shown in Table 10-13. Record all data on the PM Inspection Certificate.

Unit Power	Tester Polarity Switch	Tester Neutral or Ground Switch	Test 1 Probe Connector Screw	Test 2 Rear Panel	Optional Test 4	Optional Test 5
Enter Name of tested peripheral here:						
ON	NORM	OPEN				
ON	NORM	CLOSED				
ON	REV	OPEN				
ON	REV	CLOSED				
OFF	NORM	OPEN				
OFF	NORM	CLOSED				
OFF	REV	OPEN				
OFF	REV	CLOSED				

Table 10-17 Typical Data Sheet for Chassis Source Leakage Current

UNCLASSIFIED//FOR OFFICIAL USE ONLY
 SECTION 10-6

10-6-6 Probe Leakage Current Test

10-6-6-1 Definition

This test measures the current that would flow to ground from any of the probes through a patient who is being scanned and becomes grounded by touching some other grounded surface.

10-6-6-2 Generic Procedure for Leakage current

Measurements should be made with the ground open and closed, with power line polarity normal and reversed, and with the unit Off and On. For each combination, the probe must be active to find the worst case condition.

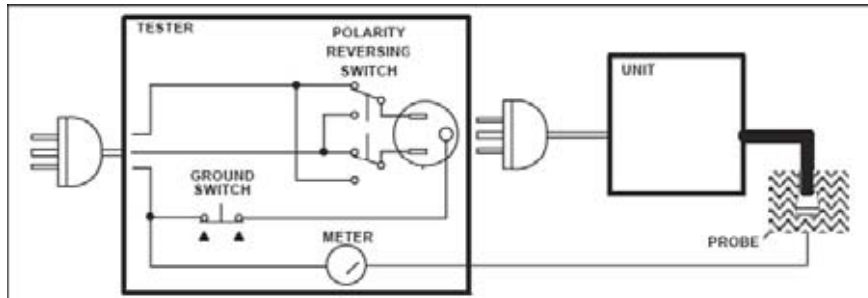

Figure 10-6 Set Up for Probe Leakage Current

Note: Each probe will have some amount of leakage current, dependent on its design. Small variations in probe leakage currents are normal from probe to probe. Other variations will result from differences in line voltage and test lead placement.

10-6-6-3 Meter Procedure Using Dale Meter to measure leakage current

The ultrasound probe's imaging area is immersed in a saline solution along with a grounding probe from the test meter to complete the current path. The Saline solution is a mixture of water and salt. The salt adds a free ion to the water, making it conductive. Normal saline solution is 0.9% salt or 1/2 gram salt per 1 liter of water. If saline is not available, a mixture of 1 quart of water with one or more grams of table salt, mixed thoroughly, will substitute.

Follow these steps to test each probe for leakage current.

- 1.) Turn the LOGIQ™ 100 PRO unit OFF.
- 2.) Plug the unit's mains powercord into the test meter, and plug the test meter into the tested AC wall outlet.
- 3.) Plug the saline probe into the test meter's "CHASSIS" connector.
- 4.) Set the test meter's "Function" switch to "CHASSIS".
- 5.) Connect the probe to be tested to the LOGIQ™ 100 PRO unit.
- 6.) Put the saline probe and the probe's face (imaging area of the probe) into the saline bath.



CAUTION

To avoid probe damage and possible electric shock, do not immerse probes into any liquid beyond the level indicated in the probe users manual. Do not touch the probe, conductive liquid or any part of the unit under test while the LIFT GROUND switch is depressed.

- 7.) Power ON the LOGIQ™ 100 PRO unit.
- 8.) Depress the LIFT GROUND rocker switch and record the highest current reading.
- 9.) Follow the test conditions described in Table 10-18 for every probe.
- 10.) Keep a record of the results with other hand copies of Planned Maintenance data.

10-6-6-4 Meter Procedure using Probe Adapter to measure Probe isolation(Sink) Current

The Dale 600/600E provides a method for testing probes independently from the system. The meter utilizes a probe adapter to apply a test potential commonly to all connector pins.

The probe's imaging area is immersed in a saline solution along with a grounding probe from the meter to complete the current path. Saline solution is a mixture of water and salt. The salt adds a free ion to the water, making it conductive. Normal saline solution is 0.9% salt or 1/2 gram salt per 1 litre of water. If saline is not available, a mixture of 1 quart of water with one or more grams of table salt, mixed thoroughly, will substitute.

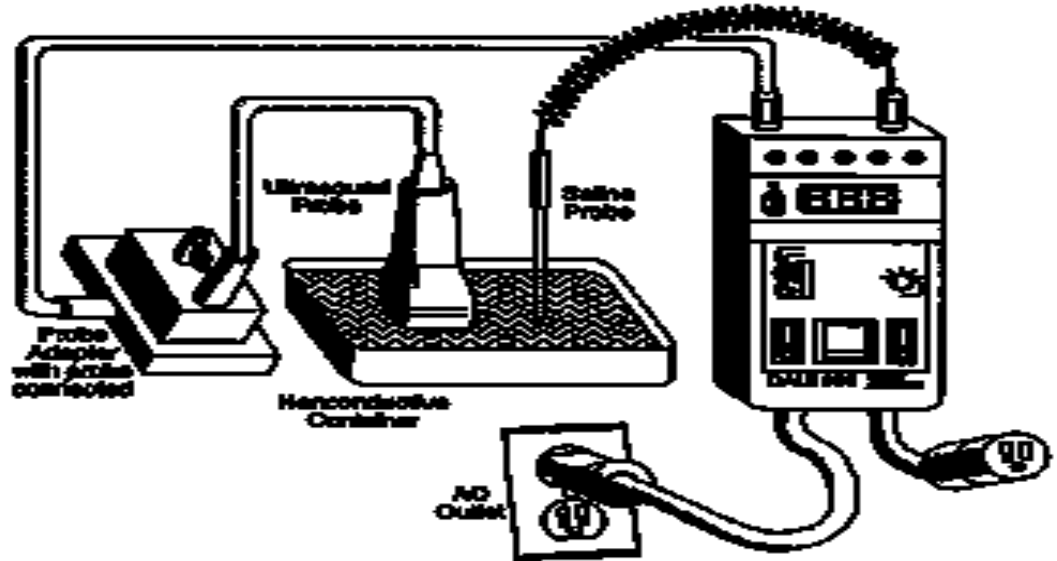

Fig 10-7 Probe Source Leakage Current Test

Follow these steps to test each probe for leakage current.

- 1.) Turn the LOGIQ™ 100 PRO unit OFF.
- 2.) Plug the unit's mains powercord into the test meter, and the meter into the tested AC wall outlet.
- 3.) Connect the probe to be tested with the meter's appropriate adapter.
- 4.) Plug the saline probe into the test meter's "CHASSIS" connector.
- 5.) Plug the probe adapter into the test meter's connector marked "EXTERNAL".
- 6.) Set the meter's "FUNCTION" switch to EXTERNAL position.
- 7.) Put the saline probe and the probe's face(imaging area of the probe) into the saline bath.



CAUTION

To avoid probe damage and possible electric shock, do not immerse probes into any liquid beyond the level indicated in the probe users manual. Do not touch the probe, conductive liquid or any part of the unit under test while the LIFT GROUNDswitch is depressed.

- 8.) Have unit power ON for the first part; turn it OFF for the second half.
- 9.) Depress the ISO TEST (Dale 600) or Mains on Applied Parts(MAP) (DALE 601) ROCKER SWITCH and record the highest current reading.
- 10.) Follow the test conditions described in Table 10-18 for every probe.
- 11.) Keep a record of the results with other hand copies of Planned Maintenance data.

10.6.6.5 Data sheet for Probe Source Leakage Current

The test passes when all readings measure less than the values shown in Table 10-14 and Table 10-15. Record all data on the Planned Maintenance Inspection Certificate.

Equipment damage possibility. Never switch the Polarity and the status of Neutral when the unit is powered ON. Be sure to turn the unit power OFF before switching them using the POLARITY switch and/or the NEUTRAL switch. Otherwise, the unit may be damaged

Probe Tested:			
Unit Power	Tester Power Polarity Switch	Tester GROUND or NEUTRAL Switch	Measurement
ON	NORM	OPEN	
ON	NORM	CLOSED	
ON	REV	OPEN	
ON	REV	CLOSED	
OFF	NORM	OPEN	
OFF	NORM	CLOSED	
OFF	REV	OPEN	
OFF	REV	CLOSED	

Table 10-18 Typical Data Sheet For Probe Source Leakage Current

Section 10-7 When There's Too Much Leakage Current...

CHASSIS FAILS

Check the ground on the power cord and plug for continuity. Ensure the ground is not broken, frayed, or intermittent. Replace any defective part.

Tighten all grounds. Ensure star washers are under all ground studs.

Inspect wiring for bad crimps, poor connections, or damage.

Test the wall outlet; verify it is grounded and is free of other wiring abnormalities. Notify the user or owner to correct any deviations. As a work around, check the other outlets to see if they could be used instead.

No outlet tester can detect the condition where the white neutral wire and the green grounding wire are reversed. If later tests indicate high leakage currents, this should be suspected as a possible cause and the outlet wiring should be visually inspected.

PROBE FAILS

Test the probe in another connector to isolate if the fault lies with the probe or the scanner.

Each probe will have some amount of leakage, dependent on its design. Small variations in probe leakage currents are normal from probe to probe. Other variations will result from differences in line voltage and test lead placement. The maximum allowable leakage current for body surface contact probe differs from inter-cavity probe. Be sure to enter the correct probe type in the appropriate space on the check list.

If excessive leakage current is slot dependent, inspect the system connector for bent pins, poor connections, and ground continuity.

If the problem remains with the probe, replace the probe.

PERIPHERAL FAILS

Tighten all grounds. Ensure star washers are under all ground studs.

Inspect wiring for bad crimps, poor connections, or damage.

STILL FAILS

If all else fails, begin isolation by removing the probes, external peripherals, then the on board ones, one at a time while monitoring the leakage current measurement.

NEW UNIT

If the leakage current measurement tests fail on a new unit and if situation can not be corrected, submit a Safety Failure Report to document the system problem. Remove unit from operation.

PM INSPECTION CERTIFICATE

Customer Name:		System ID:	Dispatch Number / Date Performed:	Warranty/Contract/HBS
System Type		Model Number:	Serial Number:	Manufacture Date:
Probe 1:	Frequency:	Scan Format*:	Model Number:	Serial Number:
Probe 2:	Frequency:	Scan Format*:	Model Number:	Serial Number:
Probe 3:	Frequency:	Scan Format*:	Model Number:	Serial Number:
Probe 4:	Frequency:	Scan Format*:	Model Number:	Serial Number:
Probe 5:	Frequency:	Scan Format*:	Model Number:	Serial Number:
Probe 6:	Frequency:	Scan Format*:	Model Number:	Serial Number:
Probe 7:	Frequency:	Scan Format*:	Model Number:	Serial Number:
Probe 8:	Frequency:	Scan Format*:	Model Number:	Serial Number:
Probe 9:	Frequency:	Scan Format*:	Model Number:	Serial Number:

* Scan Format: Phased Array, Linear Array, Curved Array, Mechanical Array or Other

**FUNCTIONAL CHECKS
 CLEANING**

**PHYSICAL INSPECTION AND
 CLEANING**

Functional Check (if applicable)	OK? or N/A
B-Mode Function	
M-Mode Function	
Control Panel	
Monitor	
Applicable Software Options	
Applicable Hardware Options	
Measurement Accuracy	
GE Approved Peripherals	

Physical Inspection and Cleaning (if applicable)	Inspect	Clean
Console		
Monitor		
Cables and Connectors		
GE Approved Peripherals (VCR, VGP)		
Probe Holders		
External I/O		

COMMENTS:

ELECTRICAL SAFETY

Electrical Test Performed	Max Value Allowed	Value Measured	OK?	Comments
Outlet (correct ground & wiring config.)				
System Ground Continuity				
Chassis Source Leakage Current - Probe				
Patient Lead Source Leakage (Lead to Ground)				
Patient Lead Source Leakage (Lead to Lead)				
Patient Lead Source Leakage (Isolation)				
Peripheral 1 Leakage Current				
Peripheral 1 Ground Continuity				
Peripheral 2 Leakage Current				
Peripheral 2 Ground Continuity				
Peripheral 3 Leakage Current				
Peripheral 3 Ground Continuity				

PROBES

Probe Number (from previous page)	Max Value Allowed	Max Value Measured	OK?	Comments
Probe 1:				
Probe 2:				
Probe 3:				
Probe 4:				
Probe 5:				
Probe 6:				
Probe 7:				
Probe 8:				
Probe 9:				

Final Check. All system covers are in place. System scans with all probes as expected.

Accepted by: _____

Your Notes: