



SECTION 4

Operating and Service Adjustments



4.1 SERVICE CHECK LIST

1. Unplug power cord.
2. Remove covers.
3. Check all screws for tightness.
4. Check infeed rollers for wear and operation. Replace if required.
5. Clean infeed rollers.
6. Check operation of separator roller mechanism, including increment stop.
7. Check separator roller for wear. Adjust or replace if required.
8. Check separator roller mechanism for tightness.
9. Check all feed rollers and wheels for wear. Replace if required.
10. Clean all feed rollers and wheels.
11. Clean pressure rollers.
12. Lubricate 8 needle roller bearings on pressure roller journals using light machine oil (remove drive pulley & roller gears on drive side of machine to gain access).
13. Check gear drive train for wear. Lubricate.
14. Check diverter mechanism for smooth operation. Ensure all diverters are aligned.
15. Check diverter solenoid is actuating correctly, and also releasing.
16. Check side guide operation and alignment.
17. Clean all sensors with air duster or air compressor.
18. Check security of PCB connectors.
19. Check security of power cord plug.
20. Switch on machine.
21. Check and test all sensor settings.
22. Feed through paper to check unit function.
23. Check correct function of output conveyor.
24. Check cover microswitch operation.
25. Switch off main machine.
26. Refit covers.
27. Clean unit as required.

Note: rubber rollers and wheels should be cleaned using only Roller Restorer Fluid, except for pickup roller which must be cleaned using only a water damped cloth. Pressure rollers should be cleaned using Isopropyl Alcohol, or alcohol based cleaner.

4.2 SERVICING AND ADJUSTMENTS

4.2.1 SEPARATOR ROLLER

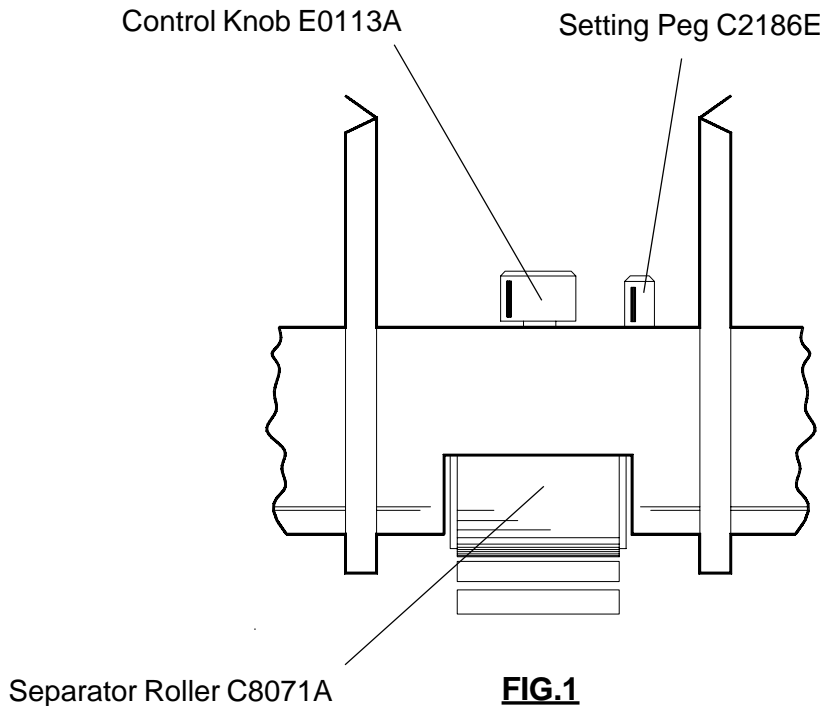

The separator roller is set via the control knob (see Fig.1 above) to allow only one form through at a time. As the roller wears, a flat occurs across the face. This is corrected by lifting setting peg and rotating the roller one stop to clear the worn section. When all stop positions have been used, the roller must be replaced.

To replace the roller, remove the separator unit complete with feed wheel shaft. The adjacent sensor shaft will have to be slackened and moved to allow withdrawal of the separator assembly. Exercise great care to avoid straining the wires. Strip the assembly to remove the roller ([exploded view, section 5.4 may assist](#)). Note that the roller pivot shaft is in two halves, held together with a set screw.

After reassembly, ensure that the hold-point sensor is correctly adjusted - [see section 4.3.1, 'Adjustment of Sensors'](#).



4.2.2 DIVERTER ADJUSTMENT

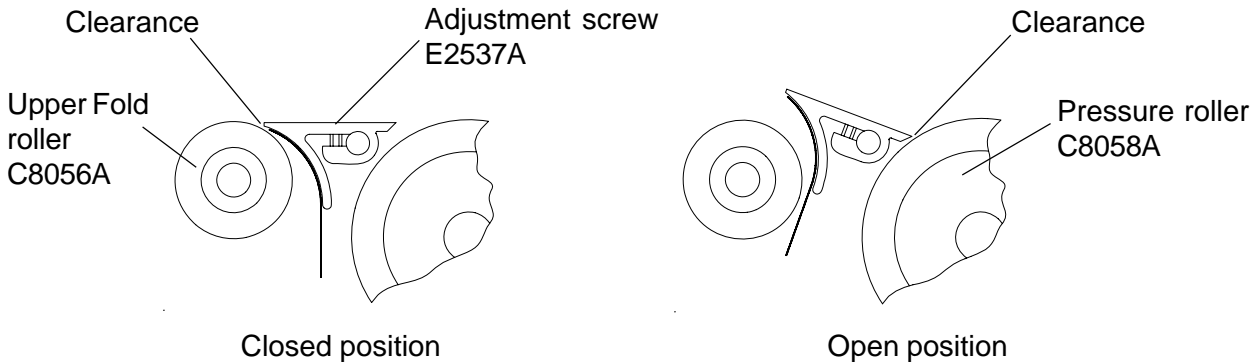

FIG. 2

The diverters should be adjusted to meet the conditions shown in Fig.2 above. A clearance of .005" (.13mm) must exist between the leading tip of diverter and upper fold roller when closed, and between trailing tip and pressure roller when open. All diverters must be in line on the shaft.

To adjust the diverters proceed as follows:

1. Move the solenoid bracket fully forward.
2. Slacken the diverter screws to adjust the solenoid lever to approx. 10° past right angle to the solenoid centre line, with the diverter tips just touching the roller in their closed position (see Fig. 3 below).
3. Turn in a piece of paper by hand so that it passes under the diverters.
4. Slide the solenoid bracket back (so opening the diverters) until it just touches the paper at the tips in the closed position (see Fig. 2 above).
5. Slide the solenoid on its bracket to the setting shown in Fig. 3.
6. Open the diverters to check clearance in the open position (see Fig. 2 above).

Note: if a diverter screw is replaced for any reason, the threads must be greased using a general purpose grease.

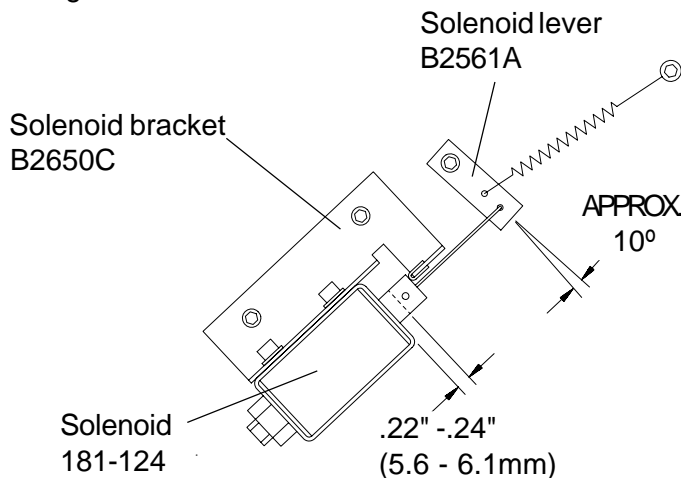

FIG. 3

4.2.3 PRESSURE ROLLER GAP

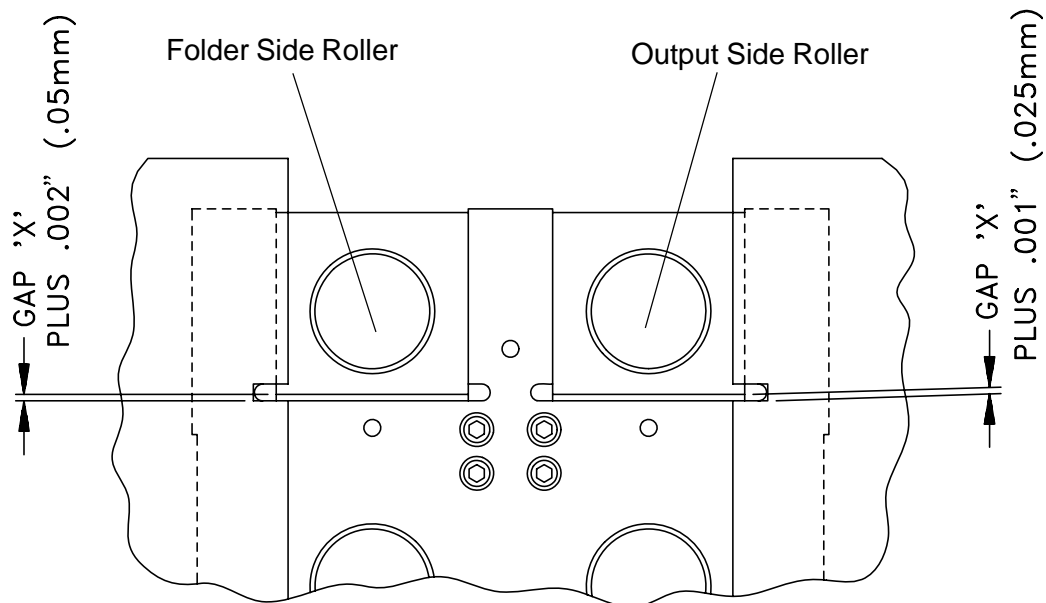

FIG. 4

The pressure rollers are factory set and should not normally require attention. However, should this be necessary for any reason, proceed as described .

Referring to [Fig.4 above](#), the proximity of the upper and lower pressure rollers should be set as follows:

1. Remove clamping pressure beams, or loosen the M10 set screws and locknuts to relieve spring tension on pressure rollers. Also remove the bearing retainers on both sides of the machine.
2. Remove any existing shims at gap 'X' (i.e.. The interface between upper and lower bearing housings) so that the upper rollers are contacting those below, with no tension applied.
3. Using feeler gauges, measure the distance at gap 'X'.
4. Fit shims in the interface at gap 'X' equal to measured gap + .002" (.05mm) on the folder side, and equal to gap 'X' + .001" (.025mm) on the output side. This applies to both LH and RH sides of the machine. Shims are available in sizes .004", .005" and .006" (.1mm, .13mm and .15mm). The lugs on the shims are located in the cut-outs within the aluminium roller housing.
5. Re-fit the bearing retainers and the pressure beams.

The pressure roller spring tension must now be set, as described in [section 4.2.4 on the next page](#).

4.2.4 PRESSURE ROLLER TENSION

The upper pressure rollers are tensioned by clamping down onto a stack of 12 disc springs (E0210A) located in each counterbored hole in the four bearing housings for the upper rollers. A Spring Peg C2414A is located through the springs for the set screws to bear upon. The disc springs are arranged as illustrated in Fig.5 below.

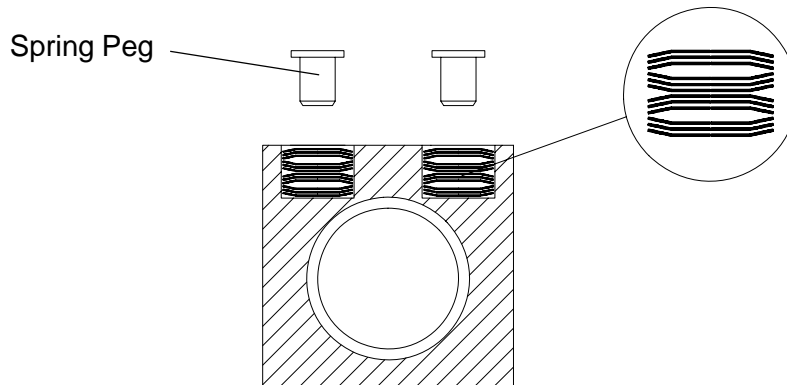

FIG.5

Tension is adjusted via the M10 set screws acting on the disc springs. Initially, the screws are set by turning downwards until contact is just made with the springs, then adding a further 1/2 turn. Tighten the locknuts, then start the machine and run several forms through to confirm that they are correctly sealed. If not, each of the sets screws must be tightened down by a further 1/8th turn at a time until effective form sealing is achieved. Ensure that all locknuts are retightened afterwards.

MCP pressure sensitive test paper should be run through the machine to check that pressure is equally exerted on both sides. If the test paper is darker on one side, then the roller pressure should be reduced on that side. Back off the screws on that side 1/8th turn at a time until the test paper shows a consistent shade.

Important: Incorrect setting of the pressure rollers can cause the motor speed to fluctuate and can result in error 'SE-2' occurring. If so, remove the white mains cover at the out put end, open the rectangular inspection plate on top of the speed controller box and check if LED1 is ON: if it is, an overcurrent condition is occurring, indicating the rollers are possibly over-tensioned and should be reset as described above. If the setting is correct, look for other causes of motor stall.

4.2.5 CLUTCH REMOVAL AND AIR GAP

The main drive clutch consists of a clutch body with a magnetically controlled core and a clutch plate attached to the drive gear. When the clutch is activated, the core is magnetically latched to the body and the drive gear rotates with it.

To remove the clutch, disconnect the cable from the PCB, slacken the two grub/cap head screws in the collar and slide the clutch body off the shaft. The clutch plate is attached to the gear using screws and is supplied as part of the clutch. When refitting, it is important to maintain the correct air gap between the clutch body and plate, which must be set to .004" as shown in Fig. 6 below. To set the gap, shims are fitted between the clutch body and plate; these are available in .002" and .010" thicknesses – see section 5.7 for part numbers. If adjustment is required, remove the clutch body, fit shims as needed and refit the body.

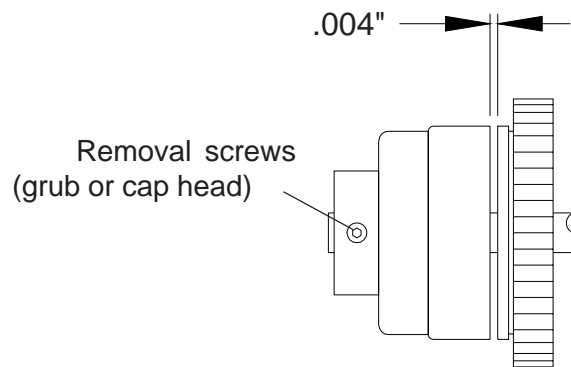

FIG. 6

4.2.6 INFEEED RETRICTOR ADJUSTMENT

The restrictor is located under the infeed tray and acts as a friction clutch to prevent shaft overrun. It comprises a spring-tensioned collar acting against a nylon restrictor plate. The spring is braced against another collar locked to the shaft with a grub screw. The collar against the restrictor plate has no screw fitted and is free to move on the shaft and press against the plate.

The factory setting for the restrictor gap is as shown in Fig. 10 below. If documents are overrunning due to inertia, check this gap and adjust if necessary by slackening the collar screw shown. Access can be gained by removing the 2 screws of the underpanel below the tray and lowering the panel downwards. Ensure the screw is tightened when adjustment is complete and replace the panel.

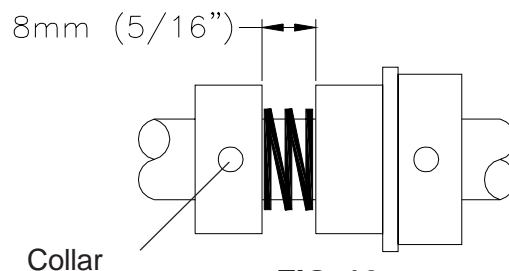

FIG. 10



4.3 ELECTRONICS AND SOFTWARE

4.3.1 ADJUSTMENT OF SENSORS

All voltage adjustments to be made with respect to TP10 (0v) on the CPU PCB.

Connector J1 - Slotted Disc Sensor

Adjust VR8 to give 0.3v (clear) between TP1 and 0v.

Now turn sensor disc to blocked position

Confirm >4.0v (blocked) between TP1 and 0v

Connector J2 - Hold Point Sensor

Adjust VR1 to give 0.3v (clear) between TP2 and 0v.

Now put 20 lbs bond (80gsm) paper between sensors to block fully.

Confirm >4.0v (blocked) between TP2 and 0v

Connector J3 - Folder Output Sensor

Adjust VR2 to give 0.3v (clear) between TP3 and 0v.

Now put 20 lbs bond (80gsm) paper between sensors to block fully.

Confirm >4.0v (blocked) between TP3 and 0v

Connector J4 - Divert Sensor

Adjust VR3 to give 0.3v (clear) between TP4 and 0v.

Now put 20 lbs bond (80gsm) paper between sensors to block fully.

Confirm >4.0v (blocked) between TP4 and 0v

Connector J5 - Output Sensor

Adjust VR4 to give 0.3v (clear) between TP5 and 0v.

Now put 20 lbs bond (80gsm) paper between sensors to block fully.

Confirm >4.0v (blocked) between TP5 and 0v

Connector J7 - Folder Input Sensor

Adjust VR5 to give 0.3v (clear) between TP7 and 0v.

Now put 20 lbs bond (80gsm) paper between sensors to block fully.

Confirm >4.0v (blocked) between TP7 and 0v

Connector J9 - Doubles Detector

LED (D12) only

Put 4 thicknesses of 20 lbs bond (80gsm) paper between the sensors and hold down with pressure wheel. Turn VR6 clockwise until D12 just comes on. Alternatively, if D1 is already on, turn VR6 anticlockwise until D12 goes off, then clockwise until it comes on.

Ensure that both doubles-detector and folder input sensors are blocked with paper.

Note: to adjust the doubles Detector, test 3 of the Engineer Service Mode must be entered. This is fully described in [section 4.3.3](#)



Sensor adjustments can be confirmed via LEDBAR1 on the CPU PCB. With voltage low (sensor clear) the relevant LED will light. With voltage high (sensor blocked) the relevant LED will not light. The relevant LED's are as follows:-

LEDBAR1	LED1	Form Length Sensor
	LED2	Hold Point Sensor
	LED3	Folder Output Sensor
	LED4	Divert Sensor
	LED5	Output Sensor
	LED6	Service Plug In
	LED7	Folder Input Sensor
	LED8	Spare
	LED9	Cover 1
	LED10	Cover 2

Similarly, the operation of various machine functions can be checked via LEDBAR2. The relevant LED will light when voltage is applied to the items indicated, even if those items fail to activate for any reason. The relevant LED's are:

LEDBAR2	LED1	Feed Roller clutch
	LED2	Brake (not fitted)
	LED3	Diverter Solenoid
	LED4	N/A
	LED5	N/A
	LED6	N/A
	LED7	Motor in forward (drive) direction
	LED8	Motor on
	LED9	N/A
	LED10	N/A

4.3.2 SETTING OF DIP SWITCH

The DIP switch (S1) on the CPU board may set for the following:

- Switch 1 - ON = Auto-calibrate on power up/hopper empty (Default OFF)
- Switch 2 - ON = Stop machine after 2 consecutive doubles (Default OFF)
- Switch 3 - Not for use (OFF at all times)
- Switch 4 - Not for use (OFF at all times)

See Fig. 7, Section 4.3.4 for position of DIP switch on CPU PCB.



4.3.3 ENGINEER SERVICE MODE

ENTERING ENGINEER SERVICE MODE

1. Switch machine off at power switch.
2. Set DIP switch S1 switch 3 to ON.
3. Switch machine on.
4. The following key sequence must be executed while the display is showing "HELLO", and steps 5 to 7 must be completed within two seconds.
5. Press STOP and JOG FORWARD keys simultaneously.
6. Press RESET OUT count key.
7. Press RESET IN count key.
8. The message "Eng Ser" will appear on the display if the above key sequence has been entered correctly and within 2 seconds.
9. Pressing the JOG FORWARD key steps through the engineer service facilities described below.

ENGINEER SERVICE FACILITIES

1. Software version. This is the EPROM version fitted.
Display shows "VER N-NN".
2. Hour count. This is the total number of hours the machine has been run since production.
Display shows the hour count to one tenth hour resolution:

"HourHHHH.H"
3. Total document count. This is the total number of documents processed since production.
Display shows ten digit count "NNNNN NNNNN".
4. Test 1 - Lamp test.
Display shows "TEST 1". Press GO key to execute test 1.
This test flashes every led on the control panel. Exited by pressing the STOP key (returns to "TEST 1" display).
5. Test 2 - Control panel test.
Display shows "TEST 2". Press GO key to execute test 2.
This test acknowledges each key press with appropriate message. Exited by pressing STOP and SETUP keys simultaneously (returns to "TEST 2" display).



- 6. Test 3 - Mechanism test.
Displays shows "TEST 3". Press GO key to execute test 3.
This test exercises the mechanical parts of the machine other tests can't reach. Also, doubles detector sensor test is carried out in while in test 3. Press GO key to execute test 3, STOP and SETUP keys to exit test 3 (returns to "TEST 3" display).

6.1 Motor Test & Speed Setting

- > GO/STOP keys turn motor on/off.
- > -/+ keys change motor speed.
- > JOG FORWARD/JOG REVERSE set motor direction FORWARD/REVERSE but only actioned with the motor stopped.
- > RESET IN key display the speed of the rollers in rpm. This display will be over-ridden if another key is pressed. Set machine speed using VR3 & VR6 on PSU PCB as shown below:

Using + button, select Speed 9. Set max. top speed using VR3 to read 225 ± 1 on display.

Using - button, select Speed 0. Set min. low speed using VR6 to read 200 ± 1 on display.

Re-check max. top speed and set again if it has altered. **Fig. 8 in section 4.3.4** shows the positions of the pots on the PSU PCB.

- > Cover switches should prevent motor from running when open.

6.2 Clutch Test

- > SETUP key pulses the clutch for approx 200 millisecs.
- > HANDFEED key toggles the clutch ON/OFF.

6.3 Divert Test

- > RESET OUT key toggles divert solenoid ON/OFF.

EXITING ENGINEER SERVICE MODE

Press STOP and SETUP keys simultaneously to exit.



4.3.4 PHYSICAL LAYOUTS OF PCBs

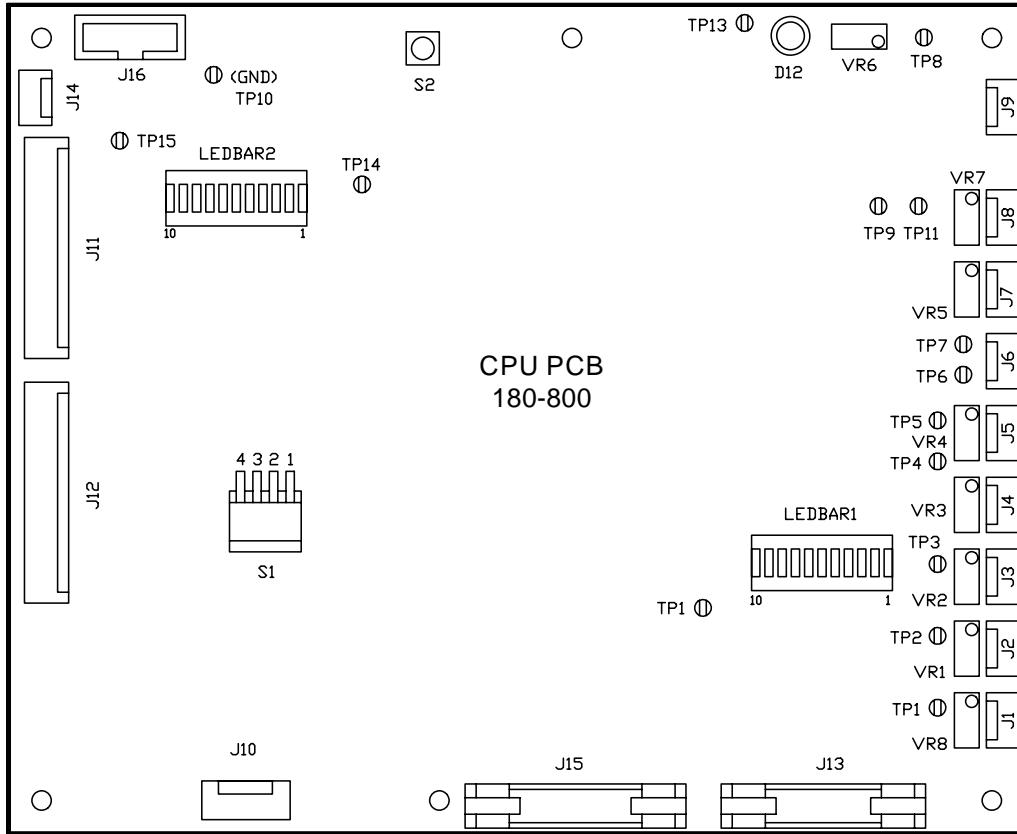

FIG. 7

For circuit diagrams and component items lists of all circuit boards, refer to **section 6** of this manual.

Refer to Fig.8 below for physical layout of Speed Control/PSU PCB

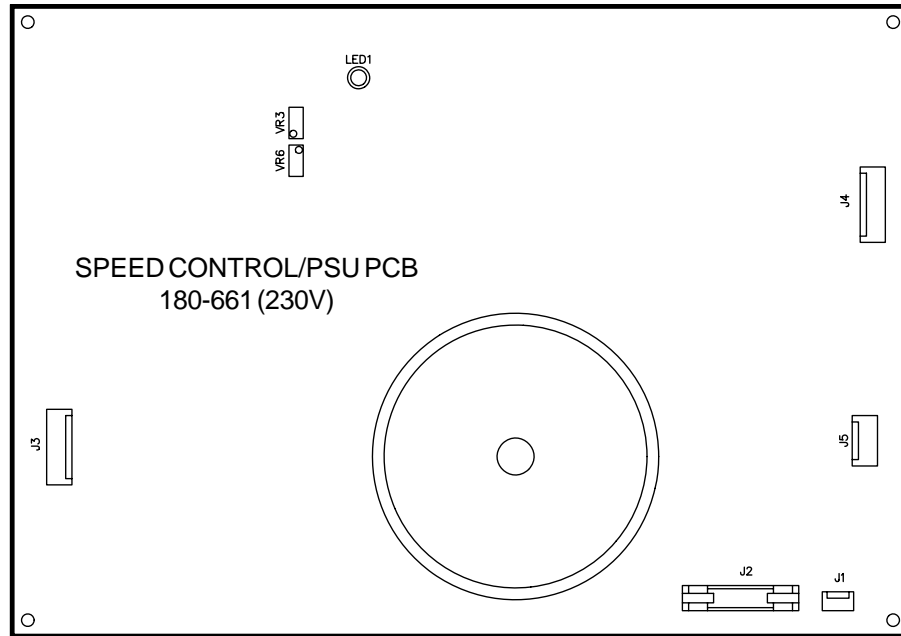

FIG. 8

Refer to Fig.9 below for physical layout of Control Panel PCB

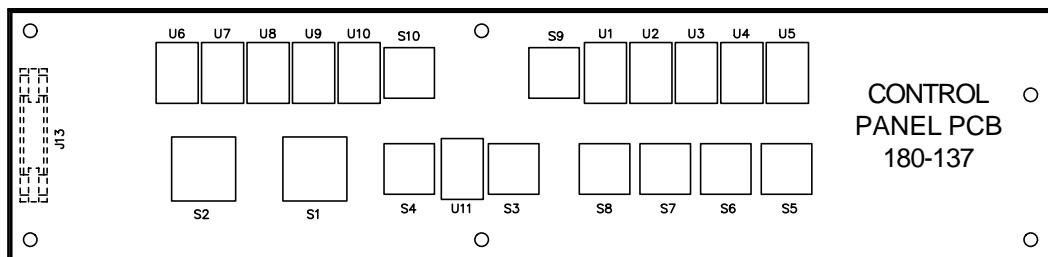

FIG. 9



4.3.5 RECOMMENDED SPARES (MECHANICAL)

Shown below are mechanical spare parts recommended to be held by Service Agents. Note that some items are voltage specific.

Quantities indicated are for every 5 machines (up to).

PART NUMBER	DESCRIPTION	QTY
179-050	PM63/50 195V MOTOR (230V MACHINES)	1
181-111	CLUTCH, LENZE TYPE	1
181-124	SOLENOID DUAL LS/SS	1
B0053A	ANTI-STATIC BRUSH	1
B1421A	OUTFEED GUIDE, UPPER	1
C0037A	THRUST WASHER	8
C8071A	SEPARATOR ROLLER	1
C7167A	PRESSURE BEAM, LH	1
C7168A	PRESSURE BEAM, RH	1
C2412A	FEED WHEEL CORE, 12mm BORE	6
C8139A	FEED ROLLER	9
C2413A	FEED WHEEL CORE, 18mm BORE	2
C8051A	PICK-UP ROLLER	2
C2411A	FEED WHEEL CORE, 8mm BORE	6
C8056A	UPPER FOLD ROLLER	3
C8057A	LOWER FOLD ROLLER	2
A0177A	PRESSURE ROLLER ASSEMBLY	4
E1000A	17mm BALL BEARING	2
E1001A	15mm BALL BEARING	1
E1029A	12mm x 18mm x 16mm ROLLER CLUTCH	4
E1030A	8mm x 12mm x 12mm ROLLER CLUTCH	4
E1038A	8mm x 12mm x 12mm PL. OILITE	2
E1039A	8mm BALL BEARING	2
E1054A	12mm BALL BEARING	11
D0017A	FEED WHEEL TYRE	14



Recommended Spares (Mechanical) contd.

PART NUMBER	DESCRIPTION	QTY
F4084A	FOLD GEAR, 20T	2
F5032A	54.5M 450 x 25 100T BELT	2
G0043A	SOLENOID LINK	1
G1024A	RETURN SPRING	2
G1025A	PRESSURE SPRING	4
G1053A	FOLD ROLLER SPRING	8
G1054A	HOLDER SPRING	4
G4005A	"T" BEARING HOUSING	10
G6091A	SHIM (.004")	12
G6092A	SHIM (.005")	6
G6093A	SHIM (.006")	6
F4095A	PINION	1
G5014A	BELT, 892.5 x 25mm	4
D0005A	JOGGLER TYRE	4
E0210A	DISC SPRING	96
C2414A	SPRING PEG	8



4.3.6 RECOMMENDED SPARES (ELECTRICAL)

Shown below are electrical spare parts recommended to be held by Service Agents. Note that some items are voltage specific.

Quantities indicated are for every 5 machines (up to).

PART NUMBER	DESCRIPTION	QTY
180-800	CPU PCB	1
180-661	SPEED CONTROL/PSU PCB (220V)	1
180-137	CONTROL PANEL PCB	1
180-664	AC MOTOR SWITCH PCB	1
123-326	PROGRAMMED EPROM, 27C128 P.S.	1
123-021	PROGRAMMED PAL, 16L8 P.S.	1
182-765	16-WAY RIBBON CABLE ASSEMBLY	1
182-165	14-WAY RIBBON CABLE ASSEMBLY	1
168-318	MAINS INPUT UNIT/FILTER	1
131-8330	STOP SWITCH, N/C	1
117-231	PHOTO DIODE ASSY. TIL 143	1
182-417	WIRED MAGNETIC REED SWITCH ASSY.	1
131-806	MAGNET FOR REED SWITCH	1
162-210	MAINS LEAD, 10A MOULDED, 2.5m (220V)	1
135-103	FUSE, 20mm 3.15A (220V)	20