

Instruction 106-6067  
9-11-09

Copyright © 2008  
by S&S® Cycle, Inc.

All rights reserved.  
Printed in the U.S.A.

# S&S® Cycle, Inc.

14025 Cty Hwy G, PO Box 215  
Viola, Wisconsin 54664  
Phone: 608-627-1497 • Fax: 608-627-1488  
Technical Service Phone: 608-627-TECH (8324)  
Technical Service Email: [sstech@sscycycle.com](mailto:sstech@sscycycle.com)  
Website: [www.sscycycle.com](http://www.sscycycle.com)



## Installation Instructions for S&S® Standard and Easy Start Gear Drive Camshafts for 2007-up Big Twin and 2006-up Harley Davidson® Dyna®

### DISCLAIMER:

S&S parts are designed for high performance, closed course, racing applications and are intended for the very experienced rider only. The installation of S&S parts may void or adversely effect your factory warranty. In addition such installation and use may violate certain federal, state, and local laws, rules and ordinances as well as other laws when used on motor vehicles used on public highways, especially in states where pollution laws may apply. Always check federal, state, and local laws before modifying your motorcycle. It is the sole and exclusive responsibility of the user to determine the suitability of the product for his or her use, and the user shall assume all legal, personal injury risk and liability and all other obligations, duties, and risks associated therewith.

The words Harley®, Harley-Davidson®, H-D®, Sportster®, Evolution®, and all H-D part numbers and model designations are used in reference only. S&S Cycle is not associated with Harley-Davidson, Inc.

### SAFE INSTALLATION AND OPERATION RULES:

Before installing your new S&S part it is your responsibility to read and follow the installation and maintenance procedures in these instructions and follow the basic rules below for your personal safety.

- Gasoline is extremely flammable and explosive under certain conditions and toxic when breathed. Do not smoke. Perform installation in a well ventilated area away from open flames or sparks.
- If motorcycle has been running, wait until engine and exhaust pipes have cooled down to avoid getting burned before performing any installation steps.
- Before performing any installation steps disconnect battery to eliminate potential sparks and inadvertent engagement of starter while working on electrical components.
- Read instructions thoroughly and carefully so all procedures are completely understood before performing any installation steps. Contact S&S with any questions you may have if any steps are unclear or any abnormalities occur during installation or operation of motorcycle with a S&S part on it.
- Consult an appropriate service manual for your motorcycle for correct disassembly and reassembly procedures for any parts that need to be removed to facilitate installation.
- Use good judgment when performing installation and operating motorcycle. Good judgment begins with a clear head. Don't let alcohol, drugs or fatigue impair your judgment. Start installation when you are fresh.
- Be sure all federal, state and local laws are obeyed with the installation.
- For optimum performance and safety and to minimize potential damage to carb or other components, use all mounting hardware that is provided and follow all installation instructions.
- Motorcycle exhaust fumes are toxic and poisonous and must not be breathed. Run motorcycle in a well ventilated area where fumes can dissipate.

### IMPORTANT NOTICE:

Statements in this instruction sheet preceded by the following words are of special significance.



WARNING

Means there is the possibility of injury to yourself or others.



CAUTION

Means there is the possibility of damage to the part or motorcycle.

NOTE

Other information of particular importance has been placed in italic type.

S&S recommends you take special notice of these items.

### WARRANTY:

All S&S parts are guaranteed to the original purchaser to be free of manufacturing defects in materials and workmanship for a period of twelve (12) months from the date of purchase. Merchandise that fails to conform to these conditions will be repaired or replaced at S&S's option if the parts are returned to us by the purchaser within the 12 month warranty period or within 10 days thereafter.

In the event warranty service is required, the original purchaser must call or write S&S immediately with the problem. Some problems can be rectified by a telephone call and need no further course of action.

A part that is suspect of being defective must not be replaced by a Dealer without prior authorization from S&S. If it is deemed necessary for S&S to make an evaluation to determine whether the part was defective, a return authorization number must be obtained from S&S. The parts must be packaged properly so as to not cause further damage and be returned prepaid to S&S with a copy of the original invoice of purchase and a detailed letter outlining the nature of the problem, how the part was used and the circumstances at the time of failure. If after an evaluation has been made by S&S and the part was found to be defective, repair, replacement or refund will be granted.

### ADDITIONAL WARRANTY PROVISIONS:

- (1) S&S shall have no obligation in the event an S&S part is modified by any other person or organization.
- (2) S&S shall have no obligation if an S&S part becomes defective in whole or in part as a result of improper installation, improper maintenance, improper use, abnormal operation, or any other misuse or mistreatment of the S&S part.
- (3) S&S shall not be liable for any consequential or incidental damages resulting from the failure of an S&S part, the breach of any warranties, the failure to deliver, delay in delivery, delivery in non-conforming condition, or for any other breach of contract or duty between S&S and a customer.
- (4) S&S parts are designed exclusively for use in Harley-Davidson® and other American v-twin motorcycles. S&S shall have no warranty or liability obligation if an S&S part is used in any other application.

Cam Name	Lobe	Timing		Duration	Lift	Centerline	TDC Lift
		Open	Close				
510G	Int	20°	38°	238°	0.510"	99.0°	0.187"
	Exh	36°	4°	252°		106.0°	0.178"
551 (E)	Int	17°	19°	216°	0.550"	91°	0.178"
	Exh	41°	17°	238°		102°	0.170"
570 (E)	Int	20°	40°	240°	0.570"	100°	0.187"
	Exh	55°	20°	255°		107.5°	0.179"
583 (E)	Int	5°	18°	203°	0.583"	96.5°	0.113"
	Exh	58°	24°	262°		107°	0.206"
585 (E)	Int	20°	45°	245°	0.585"	102.5°	0.186"
	Exh	60°	20°	260°		110°	0.179"
625 (E)	Int	20°	55°	255°	0.625"	107.5°	0.189"
	Exh	60°	20°	260°		110°	0.184"
640 (E)	Int	25°	60°	265°	0.640"	107.5°	0.228"
	Exh	65°	25°	270°		110°	0.214"

**Chart 1**

## INTRODUCTION

The S&S® cam gear drive offers many advantages over the original cam drive system:

- Reduced maintenance. There are no chain guides or shoes to wear or replace and no debris from wearing guides or shoe in you engine.
- Consistent cam timing. Cam gears are keyed with a light press fit.
- Eliminating the chains and tensioners eliminates excessive side loading of the cam support plate bearing surface.
- Critical sprocket alignment is unnecessary.
- Maintained accurate valve timing when using high performance valve springs with higher spring forces.
- Higher cam lifts can be used without decreasing cam base circle. Gear driven cams rotate in opposite direction from the chain driven cams. Lobes on the front and rear cams never point towards each other, allowing increased lobe height.

## NOTES

- 2004-up stock valve springs will handle camshafts with lift up to 0.585". If a camshaft with higher lift is installed, high performance valve springs capable of handling a greater lift must be used.
- A cam with over 0.585" of lift will cause interference between the valve spring top collar and the valve seal with stock cylinder heads.
- Piston to valve clearance will need to be confirmed when using a cam with over 0.585" of lift. Clearance should be at least 0.060" intake and .080" exhaust.
- Valve to valve clearance will need to be confirmed when using a cam over 0.585" lift. Clearance should be a minimum of 0.060".

## COMPATIBILITY NOTES:

- S&S Cam Gear Drive is not compatible with camshafts designed for the stock style chain cam drive. S&S Cam Gear Drive must be used with S&S gear drive style camshafts.
- 2006-Up gear driven camshafts kits 510G, 551G, 570G, 583G and 585G are compatible with stock 2006-Up valve springs. Due to the change in lift from the cams, new pushrods are required during installation. S&S adjustable pushrod kit 93-5095 is recommended for engines with stock length cylinders. Longer pushrods are available for engines with longer than stock cylinders. See the S&S Catalog for pushrods.
- S&S camshaft installation Kit 106-6068 is strongly recommended when installing S&S cam gear drive. This kit includes hardware, gaskets and bearings required for cam installation, this kit does not include oil pump o-rings.

## OVERVIEW OF EASY START CAMSHAFTS (IF EQUIPPED):

S&S® has developed a unique product to assist starting with a compression release cam. The premise is simple: at cranking speeds a spring loaded decompression lever holds the exhaust valve open slightly. Once the engine fires and exceeds 750 RPM, centrifugal force takes over and sends the lever to a retracted position, allowing the engine to run normally.

## Important Notes Regarding Easy Start Camshafts:

- 1- Expect a 40-60% drop in cranking compression when using these cams.
- 2- Cranking compression numbers are no longer a valid health check of the engine. We recommend performing a leak down test.
- 3- S&S does not recommend the use of travel limiters (HL2T kits) in the tappets when you install these cams.
- 4- S&S recommends that you install new lifters when installing new cams.

- 5- If any service work is performed and the lifters are not replaced, the lifters must be installed in the original position and orientation.
- 6- If the lifters have been disassembled or bled down for any purpose, the starter may have difficulty with the initial start. Although the decompression lobe lifts the lifter body, the lifter is not pumped up and it will not lift the exhaust valve. You may need to remove the spark plugs and crank the engine to get oil pressure to the lifters.
- 7- There is no service required with these cams. If you ever have the cams out for any reason, inspect the mechanism for wear and verify that the lever operates smoothly.



Picture 1 - Easy Start Gear Drive Cams

**⚠ CAUTION**

All S&S gear drive cam shafts except for the 551G, 583G, 510G, 570G and 585G require that the stock valve springs be replaced with high lift spring kits. Some high lift spring kits require clearance checks and many require cylinder head modifications to prevent contact between top color and valve seal, and to achieve correct installed height. See the instructions with your spring kit for exact specifications.

**DISASSEMBLY**

**⚠ CAUTION**

Cutting the pushrods with a saw may result in metal chips entering the engine and causing extensive damage which will not be covered under warranty.

**⚠ WARNING**

Cutting pushrods without relieving valve spring force on the pushrods may result in injury.

- 1- Remove pushrods.
  - a- Remove pushrod cover clips with a small screwdriver and compress pushrod covers to expose pushrods. Lift rear tire of motorcycle with a suitable jack. Rotate the engine until one of the cylinders is on "top dead center compression stroke" (TDCC). TDCC can be found by rolling the rear tire forward while watching or feeling the pushrods move through their travel. When BOTH pushrods are at the lowest point of their travel and the piston for that cylinder is at TDC, the engine is at TDCC. Rotate the pushrods to ensure there is no load on them. If the pushrods will not rotate freely by hand, either the engine is not on TDCC, or the lifters need to bleed down. It may be necessary to let the lifters bleed down for a few minutes before the pushrods will rotate freely.
  - b- If S&S adjustable pushrods will be used for re-assembly, the stock pushrods may be cut to remove them at this time. When cutting pushrods, S&S recommends a bolt cutter be used as it is the cleanest method. Be sure to only cut the pushrods that are not loaded and rotate freely by hand.

- c- If stock one piece pushrods are to be re-used, remove the gas tank and rocker box covers. Remove the rocker arm support by first removing the two smaller bolts which hold the breather cover in place. Next break loose the four bolts holding the rocker arm support plate in place with an alternating pattern. Remove the four rocker arm support plate bolts, and then the rocker arm support assembly. The pushrods may now be removed by sliding them up into the head slightly and then pulling the bottom of the pushrod towards you. Mark the original pushrod location as it is removed to ensure it is replaced in its original position. The intake pushrod is shorter than the exhaust pushrod. Interchanging the intake and exhaust pushrods upon reassembly, will cause the intake valve to stay open on the compression stroke and the engine will not run.
- d- Rotate the engine so the other cylinder is on TDC compression and repeat the above procedure.

2- Remove cam cover and gasket. Secure lifters with a tool made from a large binder clip spring. **See Picture 2 and 3** below.

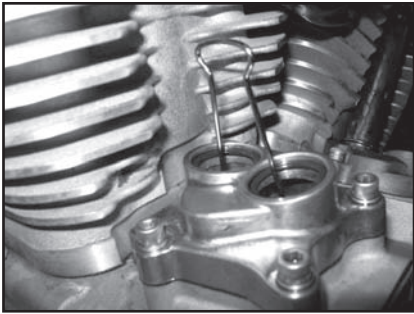

**Picture 2**

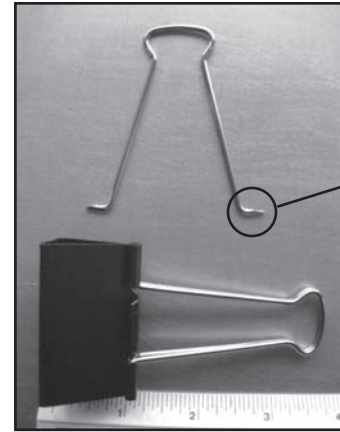

**Picture 3**

- 3- Rotate rear wheel to align timing marks on the primary cam chain.
- 4- Remove the primary chain tensioner by removing the two retaining bolts and install sprocket locking tool.
- 5- Remove the crank sprocket bolt and flat washer.
- 6- Remove rear cam sprocket bolt and flat washer.
- 7- Remove sprocket locking tool.
- 8- Gently pry off crank sprocket and rear cam sprocket.

**Cam Support Plate and Cam Removal**

- 1- Gradually loosen and remove the four oil pump bolts/washers according to the sequence shown in **Picture 4** below.
- 2- Gradually loosen and remove the six support plate bolts/washers according to the sequence shown in **Picture 4** below.

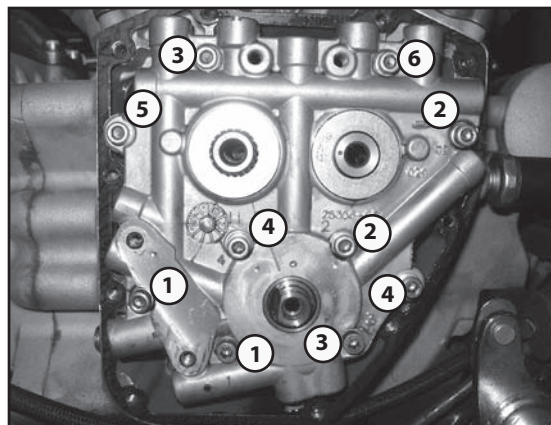

**Picture 4**

- 3- Remove spacer from rear cam, this spacer is thicker than the front spacer.
- 4- Remove cam plate and cams from engine.
- 5- Remove retaining ring and spacer from front cam. This spacer is 0.100" thick.
- 6- Remove the secondary cam chain tensioner.
- 7- Remove the cams and cam chain.



**CAUTION**

Using existing needle bearings may cause engine or cam damage due to increased tolerances from wear and higher loading of cams. Always replace cam bearings with the ones provided in this kit or another source.

**2- Installing the Cam Gear Drive**

**CAUTION**

Check pinion shaft runout. Indicate end of pinion shaft at cam support plate bushing surface and rotate engine; reading must be .003" or less total indicated runout (TIR). If reading is greater than .003" TIR the crankshaft must be repaired or replaced to correct excess runout before installing gear drive cams. Failure to correct excess runout may lead to engine damage not covered under S&S warranty.

- A- Install new needle bearings provided with the S&S® Camshaft installation kit 106-6068 or with bearings from another source. Cam bearings must be Torrington B-168 full complement bearing or equivalent.
- B- Install the new hydraulic block off plates where the front and rear chain tensioners were located, tighten fasteners to 100-120 in lbs. See **Picture 5 & 6** below.

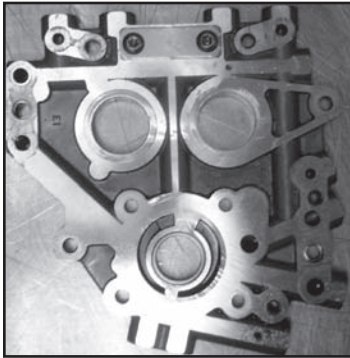

**Picture 5**

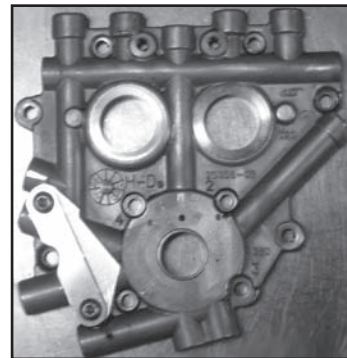

**Picture 6**

- C- When using 551G, 583G, 585G, 625G, or 640G camshafts clearance between the pinion bearing boss and the rear cam lobe must be checked. See **Picture 7 & 8** below. Remove just enough material to provide .030" of clearance between the top of the cam lobe and the pinion bearing boss when the camshafts are rotated in the inner needle bearing. Also check clearances between the cam lobe and the tappet guide bosses. To avoid contamination of the engine with chips, we recommend that all holes in the gear case be taped off with duct tape and that the gear case be thoroughly cleaned with parts cleaner or solvent after clearancing is performed.

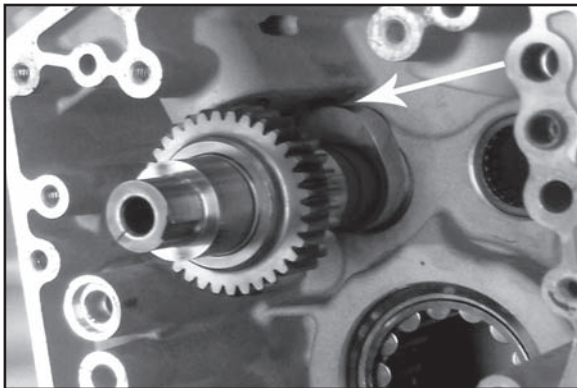

**Picture 7**



**Picture 8**

- D- Apply assembly lube to the bearing bore of the support plate and the outer races of the cam and the decompression lever, if equipped. Slide the S&S® front cam into place.
- E- Install the .110" washer on the other side of the support plate over the front cam.
- F- Install a new loaded retaining ring onto the end of the front cam to secure it in place.

**NOTE:** Before reinstalling the cam support plate make sure the oil pump o-rings are in good condition and remain in place during following procedure. Replace worn or damaged o-rings if necessary.

- G- Apply a thin layer of assembly lube to the rear cam journal, lobe surfaces, inner bearing surfaces and decompression lever, if equipped.
- H- Slide the rear cam into place aligning the two timing marks on the back of the cam gears. **See Picture 9a** below.
- I- Align the camshafts with the needle bearings in the case and carefully slide the support plate over the crankcase dowels. **See Picture 10.**

**NOTE:** The support plate assembly should slide into place without resistance. If resistance is encountered, determine the cause and correct the problem before proceeding. Do not force the support plate into position. The camshafts must be installed into the cam support plate before installation. Failure to do so could result in damage to the cam support plate and bearing surface.

- J- Recheck the cam timing by visually inspecting the timing marks on the front of the camshafts. **See Picture 9** below.

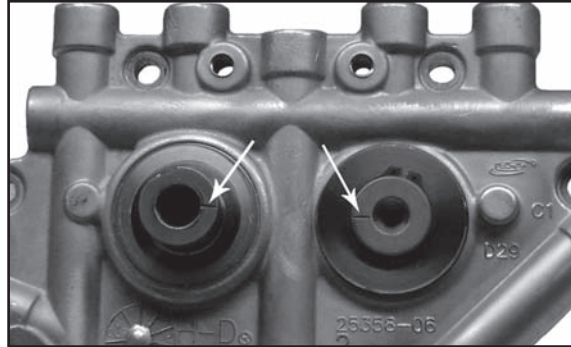

Picture 9

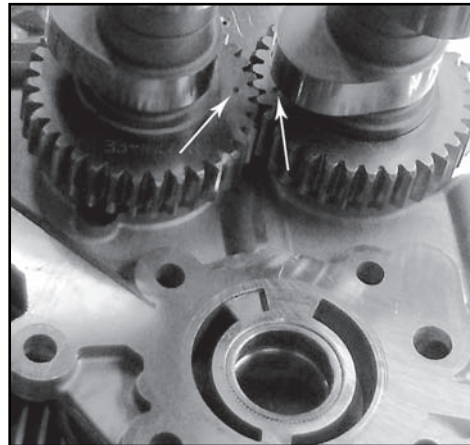

Picture 9a

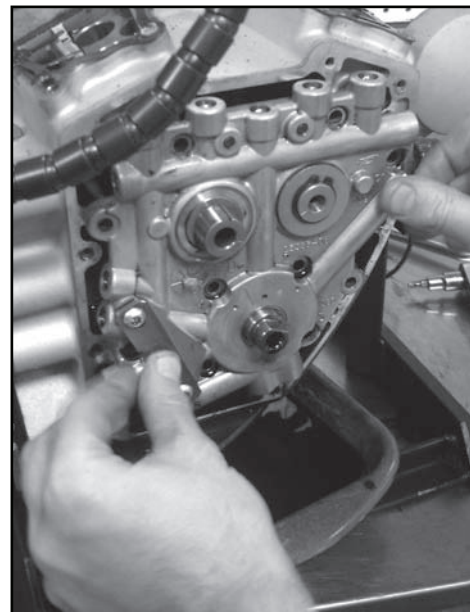

Picture 10

**CAUTION**

**Support plate screws that pass through alignment dowels can be easily stripped (See Picture 4, page 4) when applying maximum 120 in-lbs torque as recommended by Harley-Davidson®.**

- K- Loosely install the support plate screws with a drop of threadlock 242 or 243 (blue). Alternately tighten the screws to 95 in-lbs. torque following the sequence shown. **See Picture 4, Page 4.**
- L- Install the oil pump screws into locations in **Picture 4, Page 4** with a drop of threadlock 242 or 243 (blue). Screw them into the oil pump until they bottom out and then back them off ¼ turn. Rotate the crankshaft allowing the pump to find its center and alternately tighten the screws in order to 45 in-lbs. Torque the screws to 95 in-lbs and then rotate the crankshaft again checking for any binding in the oil pump gears.
- M- Check the inner camshaft gears for proper backlash. Due to the manufacturing tolerances of the cam support plate camshaft alignment may cause the inner gears to bind or become too loose. Check the rear cam for endplay by moving the camshaft in and out of the cam support plate while rotating the cam in several positions 360°. There should be no binding in any position when rotated. If binding does occur replace the rear inner cam gear with a undersized inner gear (PN 33-4277). Too much backlash between gears can cause excessive wear and valve train noise use the oversized inner gear (PN 33-4278) to decrease backlash. Over and undersized inner gears are not supplied with this kit.

**NOTE:** Crankshaft and Outer cam drive gears have a light press fit on their respective shafts. Start gears squarely on their shafts and use their mounting bolts to pull them all the way into position.

- N- Place the crankshaft gear on the crankshaft with the timing mark outward. Apply a drop of red threadlock 262, 271, or 272 to threads of 5/16-18 x 3/4" Grade 8 crankshaft gear bolt provided in kit (PN 33-5240) or obtain one from another source. Apply a drop of clean 20W-50 engine oil under the bolt flange. Using the washer removed in disassembly, install the crankshaft gear bolt and tighten to 25 ft-lbs torque.
- O- If necessary place the transmission in high gear and turn the rear wheel to rotate the engine until the timing mark on the crankshaft gear is able to be aligned with the outer cam gear timing mark.
- P- Place the .188 x 150 x .57 key into the rear cam shaft keyway. Position the outer drive gear on the rear camshaft with the timing mark facing outward. Rotate the drive gear and camshafts until the drive gear and crankshaft gear timing marks are aligned. **See Picture 11** below.

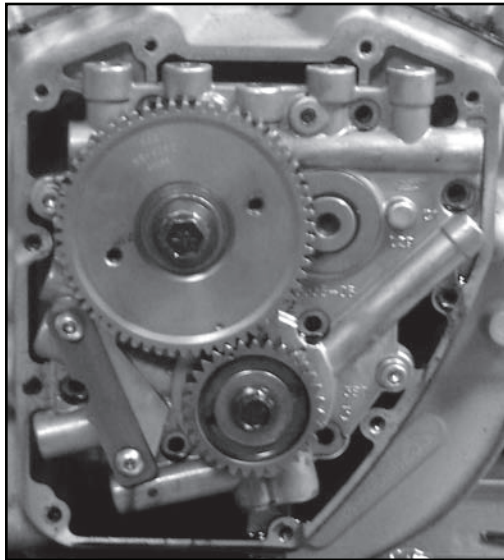

**Picture 11**

- Q- Ensure that the gear is properly aligned with the timing mark on the crank gear and the key on the rear camshaft. Start the outer drive gear by hand and use the screw and washer, 50-0132 and 50-7056, provided in the installation kit to drive the outer gear onto the rear camshaft.
- R- Apply a drop of red threadlock 262, 272 or 271 to the threads of the 3/8"-24 x 1.75" Grade 8 cam drive gear screw. Apply a drop of clean 20W-50 engine oil under the bolt flange. Using the thick washer provided, install the cam drive gear bolt and tighten to 34 ft-lbs torque.

**NOTE:** The axial thrust of the rear cam is controlled by the inner gear collar and the outer gear collar. Check the outer gear to make sure that it is fully seated against the rear cam shoulder. Failure to fully seat the outer gear will cause needle bearing and cam support plate damage.

- S- To check backlash in the outer drive gear set, rotate the 62 teeth cam drive gear back and forth while keeping the pinion gear locked in one place with the engine. The minimal required backlash for the gear set should be between .0005" and .001" and no more than .002" for cold gears. Both gear sets should roll freely with no radial or axial binding. When checking backlash the gear mesh shows less than .0005" of backlash then a smaller crankshaft gear size ( PN 33-4160X) should be used. Gear sets with less than .0005" of backlash may whine when run and can cause tooth wear, excessive heat generation with gear failure, resulting in engine damage. Gear backlash greater than .002" can cause excessive gear noise or clicking caused by the reversing of the forces applied by the lifter springs onto the cams, use the oversized crankshaft gear (PN 33-4160Z) for this situation.

**NOTE:** Cam drive gears are slightly larger than the stock drive sprockets and need to be checked for interference with the cam cover before proceeding.

- T- Press a small amount of kneadable clay or putty on the cam cover mounting boss shown. **See Figure 1** below. Carefully hold the cover and cover gasket in the position against the crankcase. Install mounting bolts (4) near the corners of the cover finger tight. Push or tap the cam cover towards the engine.

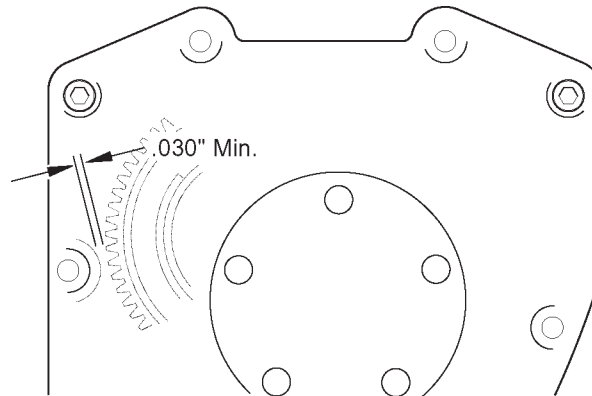

Figure 1

- U- Carefully remove the cam cover. Determine the cover to gear clearance by measuring the impression left in the clay by the gear at its thinnest point. Clearance should be .030" or more. If clearance is less than .030", or if the cover contacts the gear, remove only enough material from the cam cover to obtain the correct clearance. Repeat Steps T and U if necessary.

**CAUTION**

**Be careful not to grind too deeply and break through to the outside of the cam cover. Damage to the cam cover caused by removing too much material is not covered under warranty.**

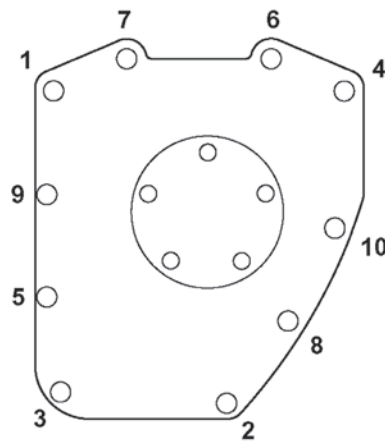

Figure 2

- V- Use a new cam cover gasket and install the cam cover. Tighten the cover bolts 90-120 in-lbs torque in sequence shown. **See Figure 2** above.
- W- Remove clips to release lifters. If necessary, place transmission in high gear and turn rear wheel to rotate engine until both lifters of front cylinder are at lowest point on camshaft. The engine is now at TDC of compression stroke for front piston. If equipped with compression releases, you must use extra care when adjusting pushrods. Because the decompression lobe is near TDC, it is possible to adjust the pushrod while the tappet is on the lobe if it is not exactly at TDC. This will cause incorrect exhaust pushrod adjustment. To verify correct position, you can rotate the engine in the forward direction and feel for the exhaust tappet to slightly lift ( about .030") and set back down on base circle. This is the proper point to adjust the pushrods.
- X- Loosen locknuts on adjustable pushrods and turn adjusters to make all rods as short as possible.
- Y- Longer S&S® pushrods are for exhaust valves, and shorter ones are for intake. Pass one long and one short pushrod through assembled pushrod covers. Place pushrod and cover assemblies through lifter cover. Inner tappet hole is for intake pushrod, and outer tappet hole is for exhaust pushrod. While holding a new gasket under lifter cover, install push rod, pushrod cover, lifter cover, and gasket as an assembly on crankcase. Tighten lifter cover screws to 95 in-lbs. torque.



**NOTE:**

- If using unmodified original tappets, perform steps 3-A thru 3-D to adjust pushrods, see below. If S&S HL2T kit has been installed in tappets, proceed to steps 4-A thru 4-F. See below.
- S&S does not recommend installing an HL2T kit in the lifters when using compression release camshafts.

**3- Pushrod Adjustment Procedure - For Unmodified Stock Tappets, and S&S Tappets without HL2T Kit**

- A- Turn adjuster screw to lengthen exhaust pushrod until pushrod has no vertical movement but still rotates with light finger pressure. Extend pushrod by rotating adjuster screw an additional 21 flats and secure adjuster screw with locknut.
- B- Repeat step 3A for intake pushrod.
- C- Lifters should bleed down in 5-10 minutes, allowing pushrods to be rotated with light finger pressure. Extend pushrod covers and install cover clips.

 **CAUTION**

**Rotating engine before lifters have bled down may damage pushrods and other components not covered under warranty.**

- D- Rotate engine until it is at TDC of compression stroke for rear piston (following procedure outlined above). Repeat steps 3A-C for rear pushrods.

**4- Pushrod Adjustment Procedure - For Tappets With HL2T Kit Installed**

- A- Bring piston to TDC on compression stroke in cylinder to be adjusted. Normally both tappets will be at their lowest point of travel.
- B- Extend pushrod adjustment, collapsing lifter until piston assembly is in contact with HL2T spacer and pushrod is tight. If tappets contain oil, as when pushrods are readjusted after engine has been run, or if all oil was not removed during HL2T installation, extend pushrod adjustment until valve is open (about five additional turns of adjusting screw). Allow 5 minutes for hydraulic unit to bleed down. If pushrod can be turned with fingers after bleeding down, lifter is not completely collapsed, and this step must be repeated.

**NOTE:** Perform this operation on one cylinder at a time. Do not turn engine until pushrod adjustment is complete.

 **CAUTION**

**Turning engine while valve is held off the seat could result in valve to valve or valve to piston contact and serious valve train damage.**

- C- Loosen pushrod adjustment until pushrod can be rotated with the fingers with slight drag. Pushrod now has zero lash.

**NOTES:**

- Shortening pushrod adjuster an additional six flats or one full turn from zero lash often results in quieter pushrod operation. This provides additional travel for the hydraulic piston assembly, which can improve the ability of the hydraulic unit to maintain zero lash under normal operating conditions.
- Harley-Davidson® Twin Cam 88® lifters require HL2T Kit 33-5339 for 1986 and later engines.

- D- Tighten lock nut and recheck pushrod adjustment to insure that it is still correct.
- E- Follow the same procedure for all four pushrods.
- F- Replace any remaining parts removed to facilitate gear drive cams installation. Check engine oil level. Start engine and check for leaks.

**NOTES:**

- After a few hundred miles it is a good idea to recheck pushrod adjustment in a new engine as valve train may tighten up due to gasket compression and valve seat wear.
- Upon initial start up after modification, HL2T equipped lifters may be somewhat noisy for 10-20 miles. If lifters are still noisy after 20 miles it is recommended that pushrods be adjusted ½ turn looser.

**Special notes on operation of motorcycle with compression release camshafts:**

- The engine idle should be set at 1000-1100 RPM.
- If your bike is carbureted, the starting routine may be slightly different, allow yourself time to experiment to find the best method.
- When the engine is turned off, you may hear a slight click. This is the decompression lever resetting, and is normal. Occasionally this may be quite loud but is still normal and does no harm.
- If you allow engine speed to go below 900 RPM, you may hear clicking as the decompression lever starts engaging. Your engine may stall if this happens. If this happens frequently, the idle speed should be adjusted higher.
- If the lifters have been disassembled or bled down for any purpose, the starter may have difficulty with the initial start. Although the decompression lobe lifts the lifter body, the lifter is not pumped up and it will not lift the exhaust valve. You may need to remove the spark plugs and crank the engine to get the oil pressure to the lifters.

**S&S® GEAR DRIVE CAM REPLACEMENT PARTS FOR 2007-UP BIG TWIN AND 2006-UP HARLEY-DAVIDSON® DYNA®**

1-	Pinion Gear.....	<b>33-4160</b>	17-	Cam Installation Kit.....	<b>106-6068</b>
	Pinion Gear, Undersized .....	<b>33-4160-X</b>		(Includes #3, 4, 5, 6, 8, 9, 12, 16)	
	Pinion Gear, Oversized .....	<b>33-4160-Z</b>	18-	Outer Cam Drive Gear Kit .....	<b>33-4268</b>
2-	Outer Cam Gear .....	<b>33-4269</b>		(Includes #1, 2, 7, 11, 15)	
3-	Side Plate .....	<b>33-4264</b>	19-	Cam Gear Kit .....	<b>33-4285</b>
4-	Top Plate .....	<b>33-4265</b>		(Includes #1, 2, 7, 11, 13, 14, 15)	
5-	Screw HHC 5/16-18 x 3/4" .....	<b>50-0100</b>	20-	Outer Gear Hardware Pack.....	<b>33-4271-P</b>
6-	Screw BHTS 1/4-20 x 3/4" .....	<b>50-0288-S</b>		(Includes # 7, 11, 15)	
7-	Washer, Flat 3/8" x 1 1/8" x .225" .....	<b>50-7056</b>	21-	Camshafts 510G .....	<b>33-5251</b>
8-	Thrust Washer, .110".....	<b>50-1103</b>		(Includes 13, 14)	
9-	Retaining Ring, Bowed #78 .....	<b>50-8286-S</b>		Camshafts 570G .....	<b>33-5252</b>
10-	Key, Woodruff .125 x .5 .....	<b>50-8223-S</b>		Camshafts 585G .....	<b>33-5253</b>
11-	Key, .188 x .150 x .57 (5 Pack) .....	<b>06-1348</b>		Camshafts 625G .....	<b>33-5254</b>
12-	Gasket, Cam Cover (10 Pack).....	<b>31-2032-S</b>		Camshafts 640G .....	<b>33-5255</b>
13-	Front Inner Gear .....	<b>33-4273</b>	22-	Camshaft 510G Kit.....	<b>33-5246</b>
14-	Rear Inner Gear .....	<b>33-4274</b>		(Includes 10,13,14)	
	Rear Inner Gear, Undersized .....	<b>33-4277</b>		Camshaft 570G Kit.....	<b>33-5247</b>
	Rear Inner Gear, Oversized.....	<b>33-4278</b>		Camshaft 585G Kit.....	<b>33-5248</b>
15-	Screw SHCS 3/8-24 x 1 3/4" .....	<b>50-0132</b>		Camshaft 625G Kit.....	<b>33-5249</b>
16-	Needle Bearing (2 Pack).....	<b>31-4499</b>		Camshaft 640G Kit.....	<b>33-5250</b>

