



# INSTRUCTIONS

-J03437

REV. 8-17-2004

Kit Number 69285-05

## CHROME AUXILIARY LAMP KIT

### General

This auxiliary lamp kit fits:

- All 1993 and later FXDWG models.
- 1984 and later FXST, FXSTB and FXSTC models.

#### NOTE

Auxiliary / fog lamps are not included in this kit. The desired style of lamp must be purchased separately. HDI (International) motorcycles should only use approved fog lamps.

See the Service Parts illustration on the last page of these instructions for kit contents.

This kit is **not** compatible with Handlebar Reservoir Cover Sets 46098-98 or 56099-98, due to the location of the switch.

Models with turn signals mounted on the upper or lower triple clamp will also require Front Directional Relocation Kit (Part No. 68603-01), available separately at any Harley-Davidson Dealer:

#### CAUTION

It is possible to overload your motorcycle's charging system by adding too many electrical accessories. If your combined electrical accessories operating at any one time consume more electrical current than your vehicle's charging system can produce, the electrical consumption can discharge the battery and cause vehicle electrical system damage. See a Harley-Davidson Dealer for advice about the amount of current consumed by additional electrical accessories, or for necessary wiring changes. (00211b)

#### NOTE

These lamps require 2.9 amps of available current from the motorcycle's electrical system.

#### WARNING

The rider's safety depends upon the correct installation of this kit. Use the appropriate service manual procedures. If the procedure is not within your capabilities or you do not have the correct tools, have a Harley-Davidson dealer perform the installation. Improper installation of this kit could result in death or serious injury. (00333a)

#### NOTE

A service manual for your model motorcycle is available from any Harley-Davidson Dealer.

### Installation

#### WARNING

To prevent accidental vehicle start-up, which could cause death or serious injury, disconnect negative (-) battery cable before proceeding. (00048a)

#### WARNING

Disconnect negative (-) battery cable first. If positive (+) cable should contact ground with negative (-) cable connected, the resulting sparks can cause a battery explosion, which could result in death or serious injury. (00049a)

1. Refer to the service manual and follow the instructions given to remove the seat and disconnect the battery cables, negative cable first.

#### WARNING

Stop the engine when refueling or servicing the fuel system. Do not smoke or allow open flame or sparks near gasoline. Gasoline is extremely flammable and highly explosive, which could result in death or serious injury. (00002a)

2. Remove the fuel tank. See FUEL TANK – REMOVAL in the applicable service manual.
3. See Figure 1. The mounting brackets (1) and clamps (2) are side-specific. Select the right-hand or left-hand bracket and clamp, and install on the fork tube using two button-head screws (3) from the kit.

#### NOTE

Tighten the outer screw first.

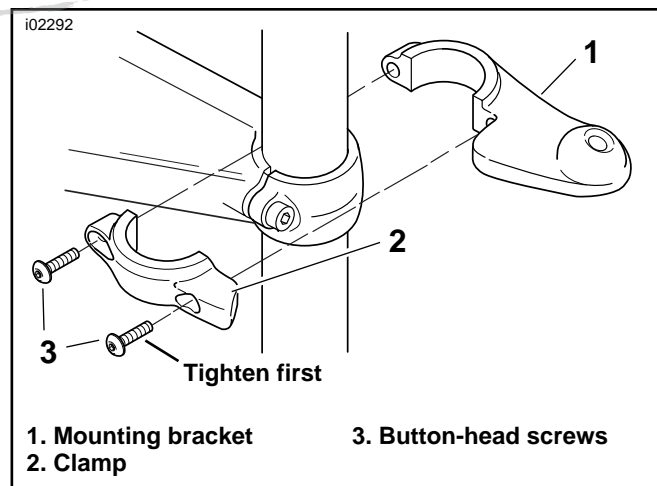

Figure 1. Install the Mounting Bracket on the Fork Tube (Right-Hand Side Shown)

4. Tighten the screws to 70-80 in-lbs (8-9 Nm).
5. See Figure 2. Route the lamp wire (1) through the hole in the mounting bracket (2), and secure the lamp (3) to the bracket using a clamp block (4), lockwasher (5) and retainer (6) from the kit.

Tighten the retainer to 16-18 ft-lbs (22-24 Nm).

6. See Service Parts illustration. Locate the outer trim ring (24), inner nesting ring (27), screw (25), and nut (26).
7. See Figure 3. Place the inner nesting ring on the bulb. Connect the black wire to the bulb spade terminal next to the bulb indexing tab (1) on the bulb. Install the gray wire on the remaining spade terminal.
8. Attached the bulb and nesting ring using the trim ring, screw and nut identified in step 6.
9. Slide the conduit (7) from the kit over the lamp wire.
10. Repeat Steps 3 through 9 for the opposite side.

### CAUTION

When routing wires along the frame backbone, make sure the wires are clear of moving parts, heat sources and pinch points, to avoid possible short circuits.

### NOTE

See Figure 4 for wiring harness component identification.

11. See Figure 5. Install the wiring harness. Place the relay (1) in the opening in the seat pan, and route the long leg of the harness (3) along the frame backbone.
12. **All 2003 and earlier models:** Cut the connector from the white power lead, and replace it with the ring terminal supplied in the kit. Connect the white wire with the ring terminal to the copper stud (BAT) terminal of the main circuit breaker.
- All 2004 and later models:** Connect the white wire with connector to the "B+" connector on the harness.
13. Connect the black ground wire (2) with the ring terminal to the ground stud under the seat, or at any good electrical ground point. Secure the kit harness to the adjacent harnesses with cable straps (Item 16) from the kit.

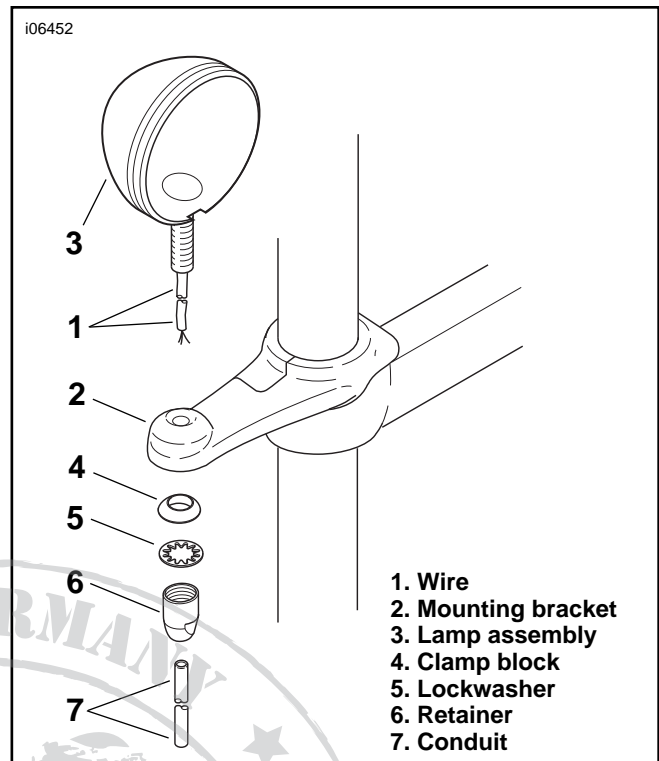

Figure 2. Install the Lamps (Right-Hand Side Shown)

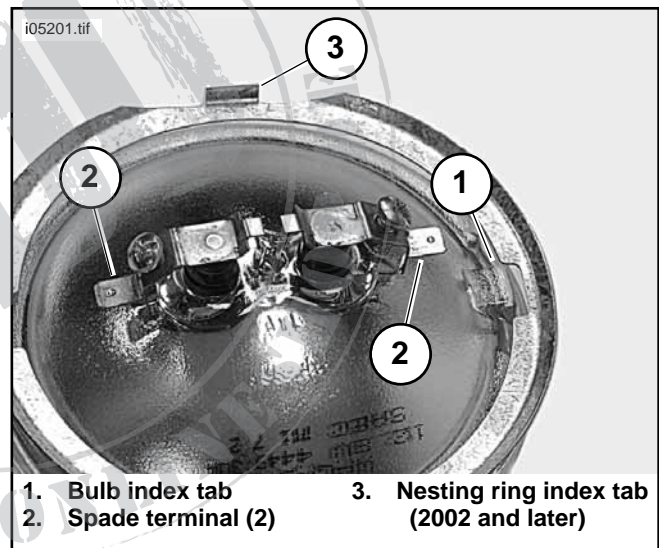

Figure 3. Auxiliary Lamp Bulb Terminals

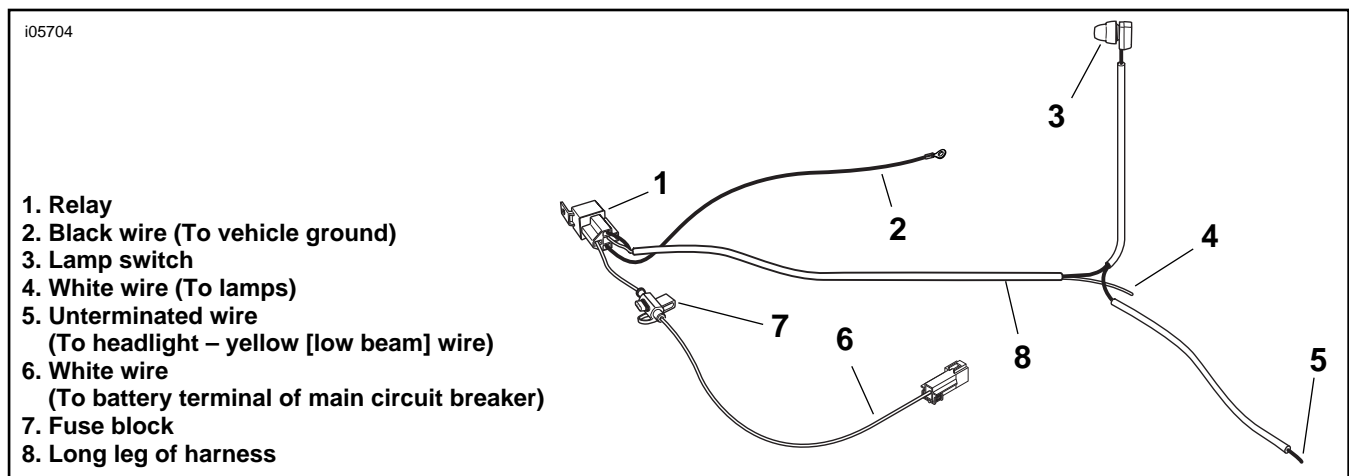

Figure 4. Wiring Harness Component Identification

## CAUTION

When routing wires through the front fork, make sure the wires are clear of moving parts, to avoid pinching and possible short circuits.

14. See Figure 4. Route the harness past the steering head, and route the lamp switch (3) leg of the harness along the left side of the handlebar to the clutch control.
15. See the Service Parts illustration. Obtain the switch mounting bracket (Item 19) from the kit. Unscrew the boot from the lamp switch, and install the switch into the bracket. Replace the boot on the switch.

### NOTE

If the boot becomes worn or damaged, or is lost, replace the boot to prevent moisture from entering the switch. See the Service Parts illustration (Item 11).

16. See Figure 6. Remove the lower screw (1) and washer from the clutch control clamp, and install the lamp switch and bracket assembly (2). Install the screw and washer and tighten to 60-80 **in-lbs** (7-9 Nm).

**For International Applications:** Place the fog lamp switch label (3) on the clutch control clamp.

17. See the Service Parts illustration. Secure the lamp switch leg of the harness to the handlebar using the wire harness retainers (Item 18) as needed. Snap the retainers into the holes in the handlebar.
18. Remove the headlamp assembly. See HEADLAMP-REMOVAL instructions for the correct model in the service manual.

### NOTE

When wired as follows, the auxiliary lamps can only be operated while the main headlamp is on low beam. This conforms to many state and local laws.

19. See Figure 7. Route the unterminated wire (1) from the switch through the grommet into the headlight housing. Splice it to the yellow (low beam) wire (2) using the Scotchlok® electrical connector (Item 14) from the kit.

### NOTE

To route the wire through the grommet, push a hooked piece of wire through the grommet from the inside of the headlamp housing. Soap the toggle switch wire and pull it back through the grommet with the hooked wire.

In some applications the wire from the kit harness may not fit through the headlight housing grommet. If this is the case, splice the black wire to the yellow wire outside the headlight housing, then tape the connector to shield it from moisture.

20. Install the headlamp assembly. See HEADLAMP – INSTALLATION instructions for the correct model in the service manual.

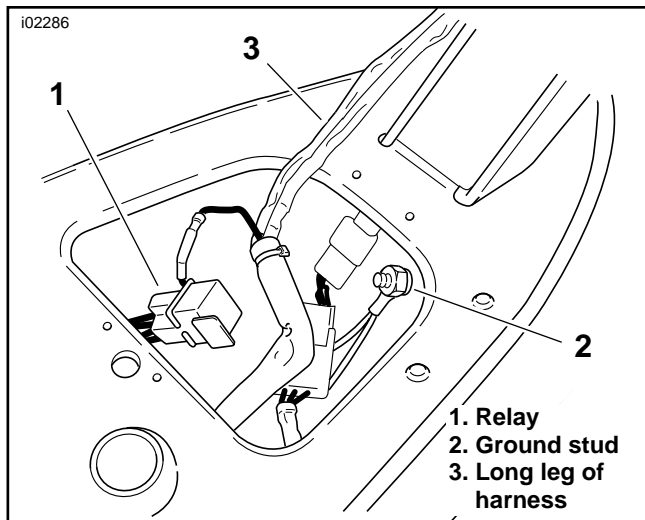

Figure 5. Install the Wiring Harness (FXDWG Shown)

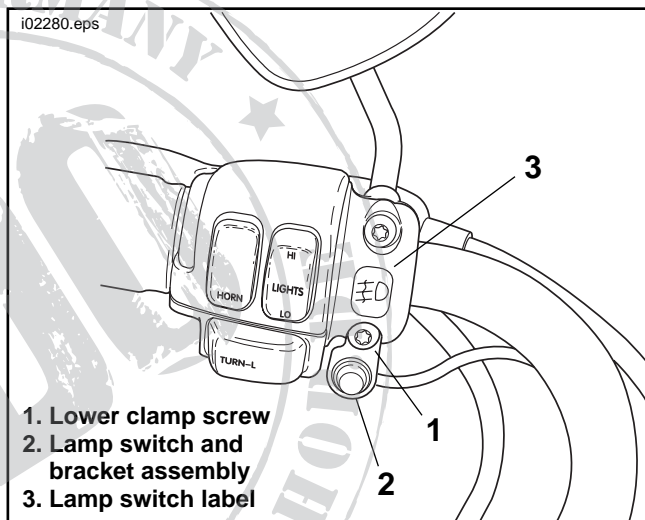

Figure 6. Install the Lamp Switch on the Clutch Control Clamp (1996 and Later Shown)

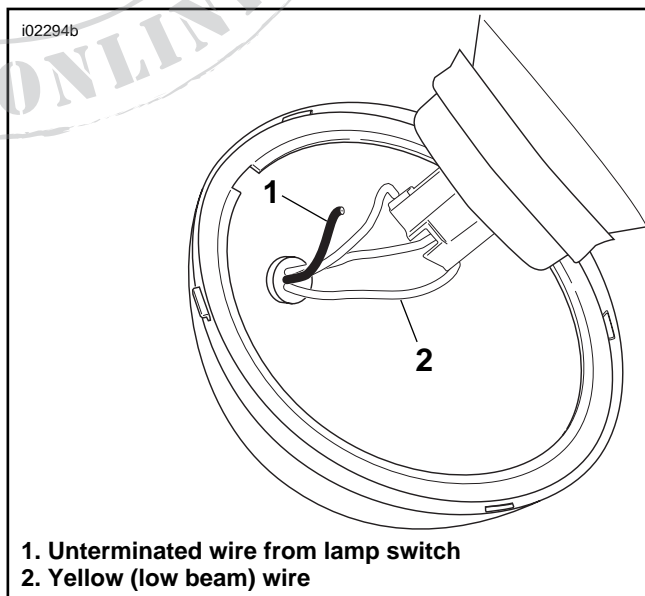

Figure 7. Splice the Unterminated Wire from the Switch to the Headlight Yellow (Low Beam) Wire

21. See Figures 8 and 9, and the SEALED BUTT SPLICE CONNECTORS section of the service manual. Slide the heat-shrink tubing (1) over the white wire (2) from the kit harness, and crimp the electrical connector (3) to the wire with a Crimp Tool, Part No. H-D 38125-8.
22. Bring both lamp wires (4) to the connector. Trim the wires, allowing approximately 1 inch (25 mm) of the wire to extend past the butt splice connector. Trim the conduit (5) approximately 1-1/2 in. (38 mm) back from the end of the wire.
23. Remove approximately 3/8 in. (10 mm) of insulation from the end of the lamp wires.
24. Insert the ends of both lamp wires (4) into the electrical connector (3) and crimp the wires to the connector with the crimp tool.

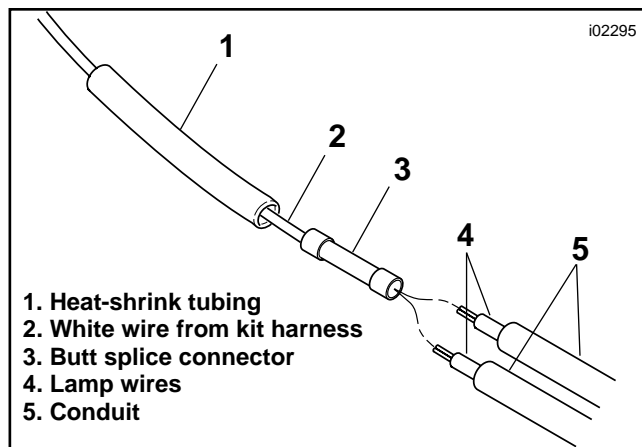

Figure 8. Connect the Lamp Wires to the Kit Harness

**WARNING**

Be sure to follow manufacturer's instructions when using the UltraTorch UT-100 or any other radiant heating device. Failure to follow manufacturer's instructions can cause a fire, which could result in death or serious injury. (00335a)

**NOTE**

Protect the heat-shrink tubing from the heat source while applying heat to the electrical connector.

25. Slide the heat-shrink tubing (1) away from the splice and using the UltraTorch UT-100 (H-D 39969), Robinair Heat Gun (H-D 25070) with Heatshrink Attachment (H-D 41183), or other suitable radiant heating device, heat the crimped splice to encapsulate the butt splice connection. Apply heat from the center of the crimp out to each end until the meltable sealant exudes out of both ends of the connector. Let the connector cool.
26. Slide the heat-shrink tubing back over the splice and using the same radiant heating device, heat the tubing to encapsulate the butt splice connection. Apply heat from the center of the tubing out to each end.

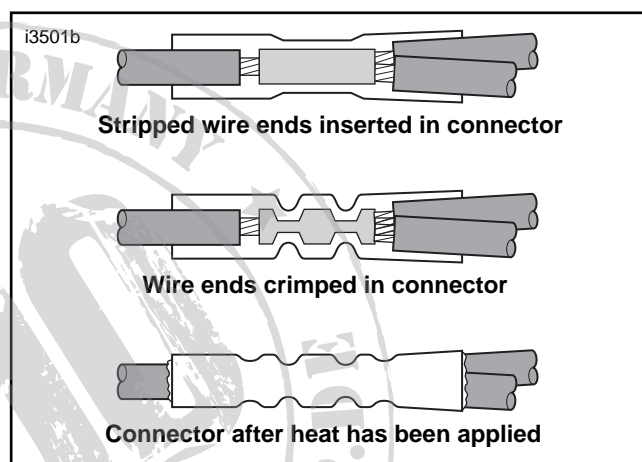

Figure 9. Installing Sealed Butt Splice Connectors

**CAUTION**

When securing the wires to the lower fork steering bracket, make sure the wires are clear of moving parts to avoid pinching and possible short circuits.

27. Secure the wires to the lower fork steering bracket using the adhesive-backed clips (Item 15) from the kit.

**WARNING**

Stop the engine when refueling or servicing the fuel system. Do not smoke or allow open flame or sparks near gasoline. Gasoline is extremely flammable and highly explosive, which could result in death or serious injury. (00002a)

**CAUTION**

Be sure that wiring harness does not get pinched between fuel tank and frame during tank installation.

28. Install the fuel tank. See FUEL TANK – INSTALLATION in the applicable service manual.

**WARNING**

Connect positive (+) battery cable first. If positive (+) cable should contact ground with negative (-) cable connected, the resulting sparks can cause a battery explosion, which could result in death or serious injury. (00068a)

29. Connect the battery cables, positive cable first.

**WARNING**

After installing seat, pull upward on front of seat to be sure it is in locked position. While riding, a loose seat can shift causing loss of control, which could result in death or serious injury. (00070a)

30. Refer to the service manual, and follow instructions to install the seat.

**WARNING**

Check for proper headlamp operation before riding motorcycle. The automatic headlamp feature provides increased visibility for riders. Be sure headlamp is on at all times during motorcycle operation. Low visibility of rider can result in death or serious injury.

31. Test headlamp high and low beams, and the auxiliary lamps for proper operation. Aim the auxiliary lamps and tighten the lamp mounting nuts.



# Service Parts

Part No. 69285-05

Date 8/04

## Chrome Auxiliary Lamp Kit

106450

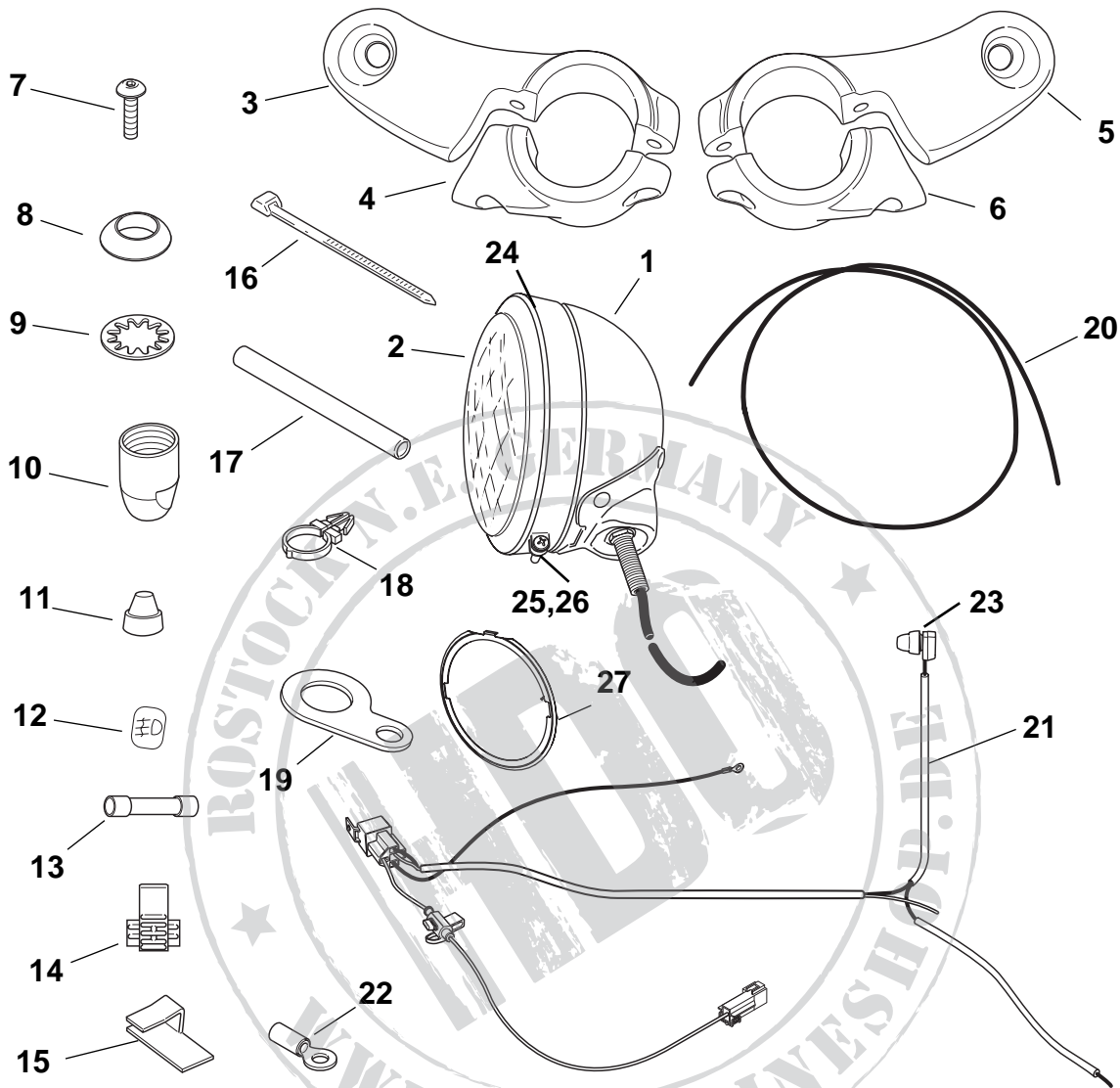

Item	Description	Part No.	Item	Description	Part No.
1	Passing lamp housing (2)	68276-02	14	Connector, electrical (Scotchlok®, blue)	70576-68
2	Sealed unit ( <i>purchased separately</i> )	reference only	15	Clip, adhesive-backed (4)	10102
3	Bracket, lamp mounting (right)	Not sold	16	Cable strap, 7.8 in. (198 mm) (12)	10181
4	Clamp, lamp mounting (right)	Not sold	17	Shrink tube	72266-94
5	Bracket, lamp mounting (left)	Not sold	18	Harness retainer (4)	70345-84
6	Clamp, lamp mounting (left)	Not sold	19	Bracket, switch mounting	Not sold
7	Screw, socket-head, 1/4-20 x 3/4 in., locking (4)	927A	20	Conduit, vinyl, 15 in. (38.1 cm) (2)	Not sold
8	Clamp block, auxiliary lamp (2)	68720-62	21	Wiring harness assembly	69104-04
9	Lockwasher, internal tooth, 3/8 in. (2)	7130W	22	Ring terminal	9858
10	Retainer, lamp mounting (2)	Not sold	23	Switch	70370-00
11	Boot, switch	67880-94	24	Trim ring	68725-62A
12	Label, lamp switch, HDI (international only)	68604-01	25	Screw	3514
13	Connector, pre-insulated, sealed, butt splice	70586-93	26	Nut	7606
			27	Inner nesting ring	68331-02