

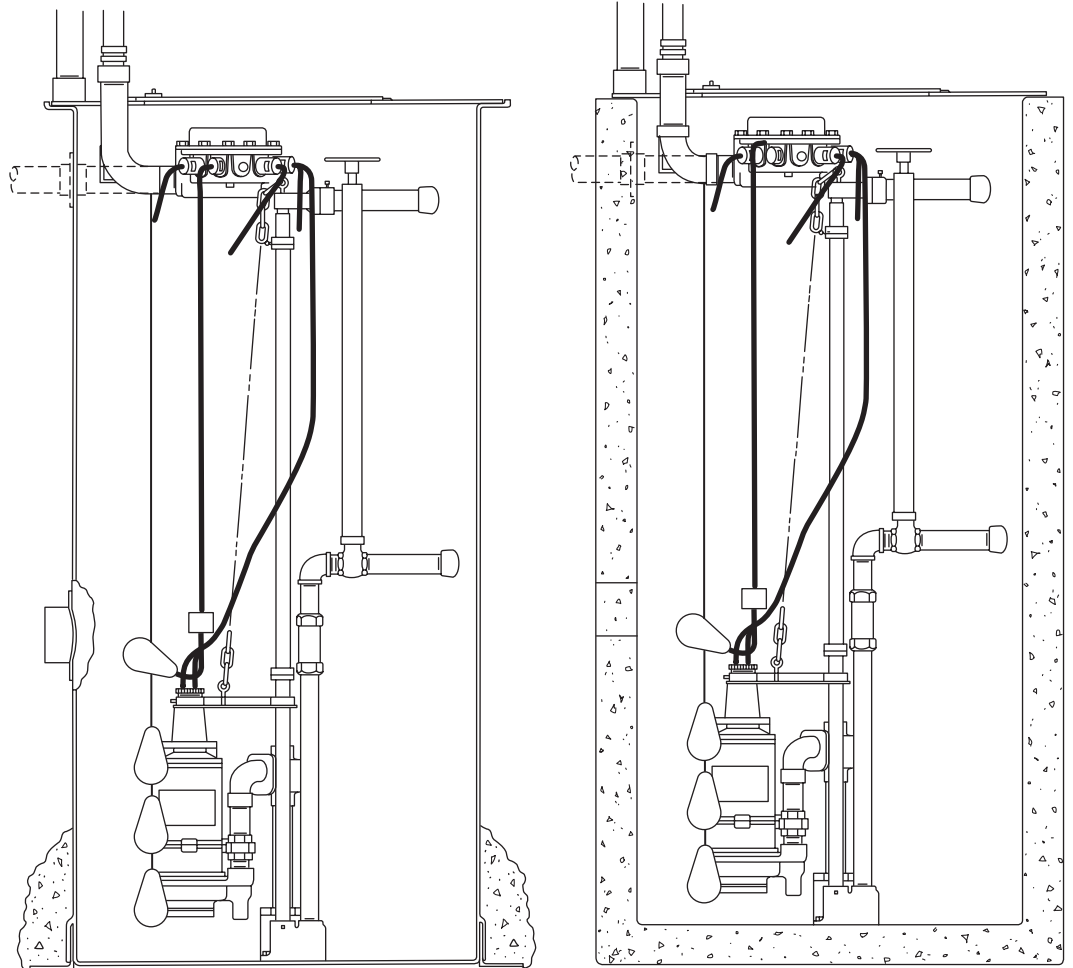

MYERS®



MODEL WG20 DUPLEX GRINDER PUMPS

INSTALLATION AND SERVICE MANUAL

For Myers WG20 Duplex Grinder Pumps with Lift-Out Rail System Installed in Fiberglass Basin at Factory as Complete System, or Rail Parts for Installing in Fiberglass or Concrete Basin by Customer.

NOTE! To the installer: Please make sure you provide this manual to the owner of the equipment or to the responsible party who maintains the system.

NOTE – When complete packaged system, including fiberglass basin, is supplied from factory all parts are mounted in basin except pump and level controls. Piping and guide plates for pumps are shipped in separate packages and must be ordered separately. Two packages are required for duplex system.

Level controls are to be ordered separately and must be mounted in basin. Controls are specified at time of order so proper brackets are mounted in basin for supporting controls. When mercury float controls are used, three are required. If optional alarm control is to be used, it must be specified at time of order so bracket can be mounted. Control box and pumps are ordered depending on voltage and phase and if NEMA 3R is required.

CALIFORNIA PROPOSITION 65 WARNING:

▲ WARNING This product and related accessories contain chemicals known to the State of California to cause cancer, birth defects or other reproductive harm.

STEPS TO INSTALL RAIL SYSTEM IN FIBERGLASS OR CONCRETE BASIN

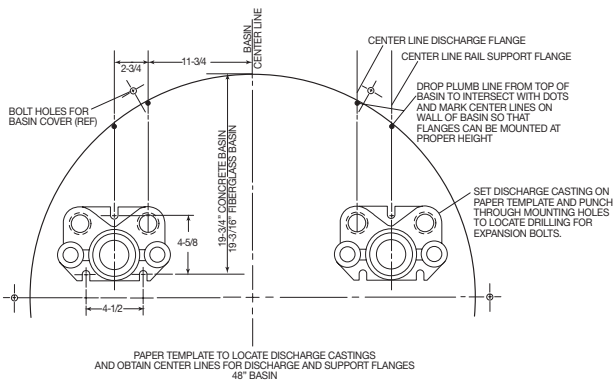

1. Unpack parts and check that all packages listed are available. Remove full size paper template to use in basin bottom to properly locate bolting for discharge cases and to locate vertical center lines for flanges. Drop plumb line from cover holes in basin rim to properly locate base castings.
2. Clean basin bottom thoroughly before placing in paper template. If basin is concrete, chip out any protruding rocks. Punch through paper for bolt hole location. Drop plumb line from top of basin for center line locations and mark center line on basin wall with chalk. If basin is fiberglass it must be mounted on level surface with walls plumb before marking. All parts should be installed in fiberglass basin before placing in ground.
3. If basin is concrete, holes must be drilled in basin bottom and side walls for mounting parts. Use machine bolt expansion sleeves 1-1/2" long 3/8" size. Use 5/8" carbide drill to drill holes. If basin is fiberglass, rubber seal washers are furnished for hold-down bolts.

4. Cut holes through concrete wall or fiberglass basin wall to locate discharge and support flanges. Pipes can be cemented into wall instead of using flanges if desired.
5. Bolt discharge cases to basin bottom. If basin is fiberglass, seal washers are furnished to seal bolt heads where bolts pass through basin bottom. Bolt all flanges in place. Do not tighten bolts completely tight at this stage as some adjustment may be necessary when rails are placed.
6. Install discharge piping from base casting to discharge flange. Be sure vertical piping is plumb so that it will not interfere with the rail guide pipes. Use slip coupling to join pipes.
7. Install 1" galv. pipe rails. Stainless steel or other corrosion resistant pipe may be used as long as the O.D. is same as 1" std. pipe, 1.315" O.D. In order to mount the rail support bracket it may be necessary to place the yoke in the rails, then push the support nipple through the yoke and screw into mounting flange. Bolts can be loosened in the flange to allow alignment if necessary. If pipe is cemented in, be sure all piping is in place and plumbed and blocked before final cementing.
8. Align 1" rails plumb by using a level in both directions on pipe. Adjust rail support yoke if necessary. Once rails are properly aligned, tighten all bolts in base castings and flanges.
9. Mount level control support brackets and install level controls on brackets and set SM25NO controls at proper levels.
10. If basin cover is used where control box is mounted directly on cover, attach aluminum connection box to 2" elbow supplied with cover before mounting cover to basin.
11. Place cover on basin and bolt in place. If basin is concrete, expansion sleeves must be installed at proper bolt locations.
12. Inlet flange must be mounted to basin at depth required to get gravity flow into basin. Flanges are available for 4", 6" or 8" pipe and more than one inlet can be used if required. Inlet hole is cut and flange is mounted in the field.

Cubic feet of concrete poured around basin to prevent flotation.

BASIN DIA.	CUBIC FEET OF CONCRETE REQUIRED PER FOOT OF BASIN DEPTH
24"	2
30"	3.5
36"	5
48"	8.5

Example – 24" dia. basin 8 ft. deep requires 2 x 8 = 16 cu. ft. of concrete to prevent flotation. If basin is installed in dry ground without surface water, 1/3 of above values may be used.

ASSEMBLING PIPING TO PUMP

Pump grinder plate and pump discharge piping is supplied with other rail parts.

1. Attach guide plate and piping to pump. Be sure piping is plumb, then tighten all set screws. Attach lifting chain to lifting eye with clevis supplied. Pumps can now be lowered into position with lifting chain. Retain power and control cords at surface as pump is lowered.

When pumps are in place, attach cords to connection box. Remove slack from wires so that they will hang vertical without tangling.

2. Connect level control cords to connection box as shown on wiring diagrams.
3. Install control box on cover and connect to cover with 2" conduit as shown.
4. Run wires to control box and connect to cords coming into connection box. Mark or trace each incoming wire so that it can be connected to proper cord.
5. **Do not pour sealing compound into fitting until pumps have been run, to be sure all connections are correct.**

NOTE – If control box is to be installed, off-set from basin. The CF-200 conduit flange must be installed in basin and connection box to be connected to flange before installing cover.

6. Install hold-down guides and 1/2" galv. hold-down pipe. Screw pipe into lower guide. Upper guides fasten to rails and hold-down pipe with set screws. The hold-down pipe is necessary to prevent hydraulic pressure from lifting pump from base seal casting. The hydraulic pressure keeps the pumps suspended when in operation so there is no side load on the rails and removal is easier when required.
7. Valve adapter and shut-off handles are connected with 1/2" galv. pipe and held with set screws. These shut-off stems are installed in 1-1/2" plastic pipe guides attached to valves.

STARTING SYSTEM

1. Open 1-1/4" bronze gate valves; turn counter-clockwise to open.
2. Set pump switches on Auto position and run water into sump until level controls starts one pump. Allow pump to operate until sump level drops, stopping pump.

IMPORTANT – Lower level control or weight should be set so that sump level drops to within 1" or 2" from bottom of pump before stopping pump.

3. Turn both pump switches to Off and fill sump until level is to override control, then turn both pump switches to Auto position. Both pumps should

come on and operate until sump level drops to the Off position.

4. Leave both pump switches to Off and fill sump until level is to override control, then turn both pump switches to Auto position. Both pumps should come on and operate until sump level drops to the Off position.
5. Leave both pump switches to Auto position and system is now ready for automatic operation.

IN CASE OF TROUBLE CHECK THE FOLLOWING:

Pumps will run but not deliver water.

1. Probably air lock. Start and stop pump several times. If this does not clear air turn both pumps to Off and run more water into sump 6" to 12" higher. If air still does not clear it may be necessary to raise hold-down pipe and lift pump so that lower seal fitting is out of the discharge case to release air.
2. Be sure shut-off valve is open in discharge line.
3. If pump is 3 phase be sure rotation is correct. Grinder impeller must rotate counterclockwise when looking at pump inlet. **Do not** put fingers near grinder impeller.

Pump seal fitting does not hold tight.

1. Probably cut or broken O-ring. Replace if necessary. Trash may be caught in seal flange. Lift pump and open shut-off valve to back flush discharge casting.

On installation where discharge line is not filled it may be necessary to lift pump until seal flange is out of discharge case, then run pump to flush casting.

For all other trouble problems with pump or control box refer to pump and control box instructions included with these items.

CAUTION – **Never work on pumps or controls unless power is turned off. If pump is remote from control box, disconnect wires to pumps to be certain power cannot be turned on when working on pumps. Never put fingers near grinder impeller when pump cord is connected.**

MYERS DUPLEX LIFT-OUT RAIL SYSTEM IN 36" OR 48" CONCRETE BASIN

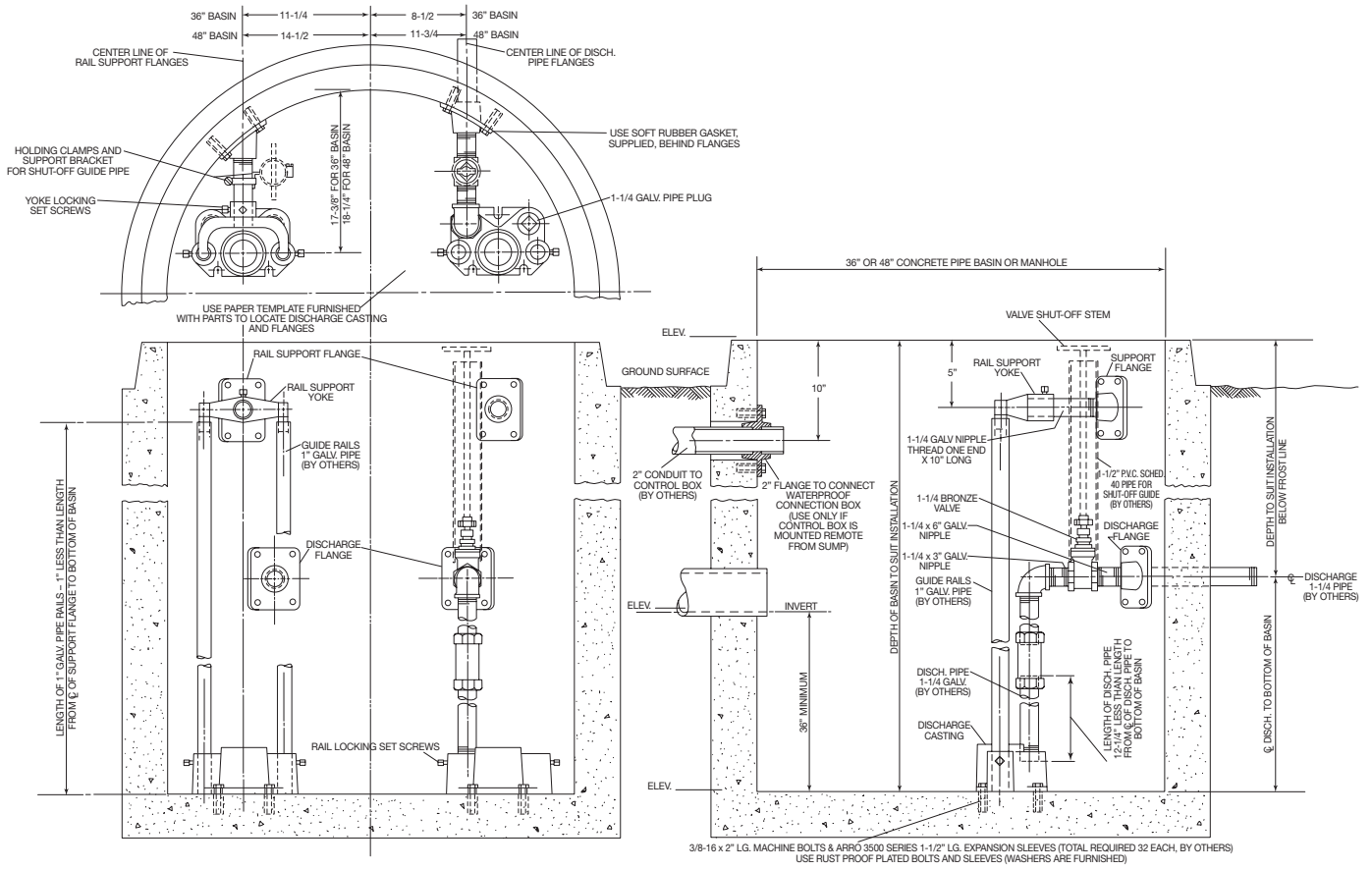

MYERS DUPLEX LIFT-OUT RAIL SYSTEM IN 36" OR 48" FIBERGLASS BASIN

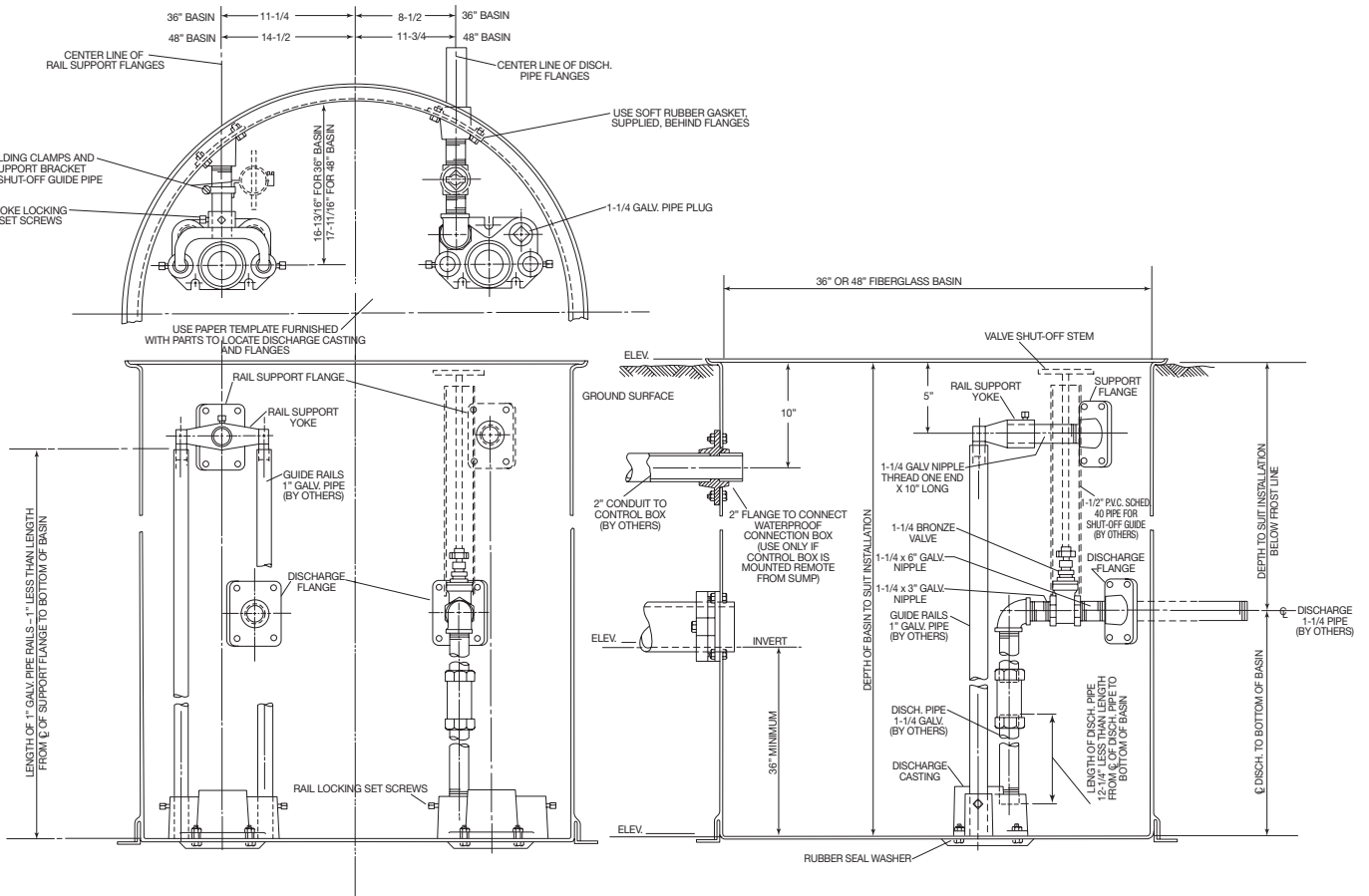

MYERS DUPLEX LIFT-OUT RAIL SYSTEM IN 36" OR 48" FIBERGLASS BASIN

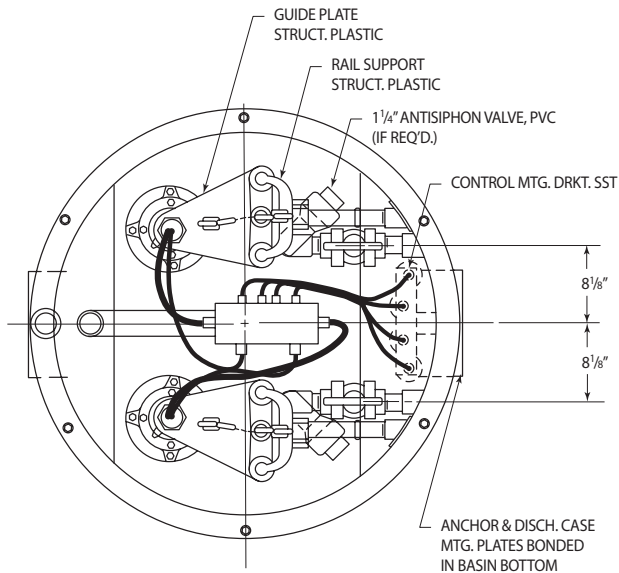
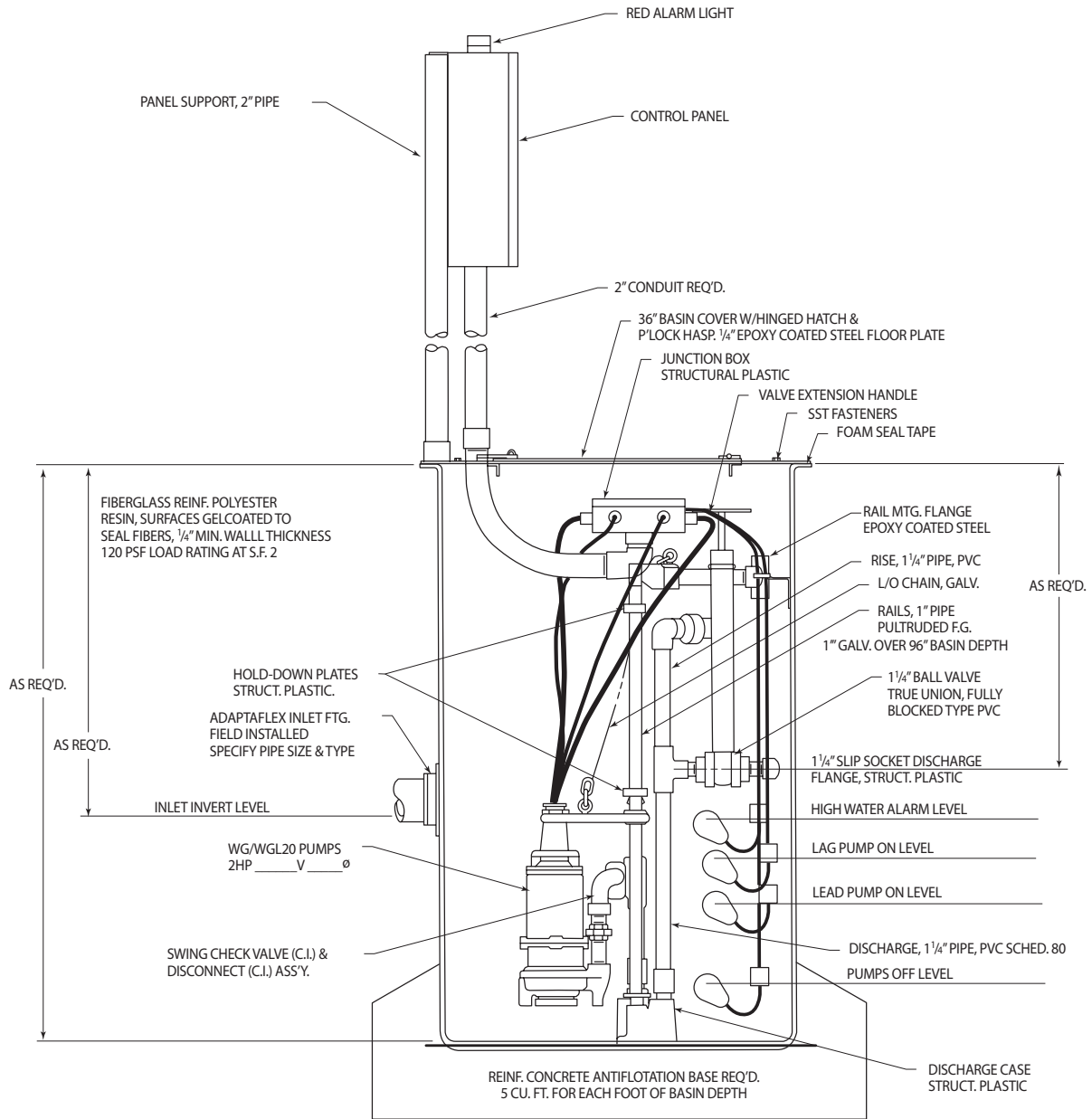

LIFT-OUT RAIL SYSTEM INSTALLED IN ON-SITE CONCRETE MANHOLE

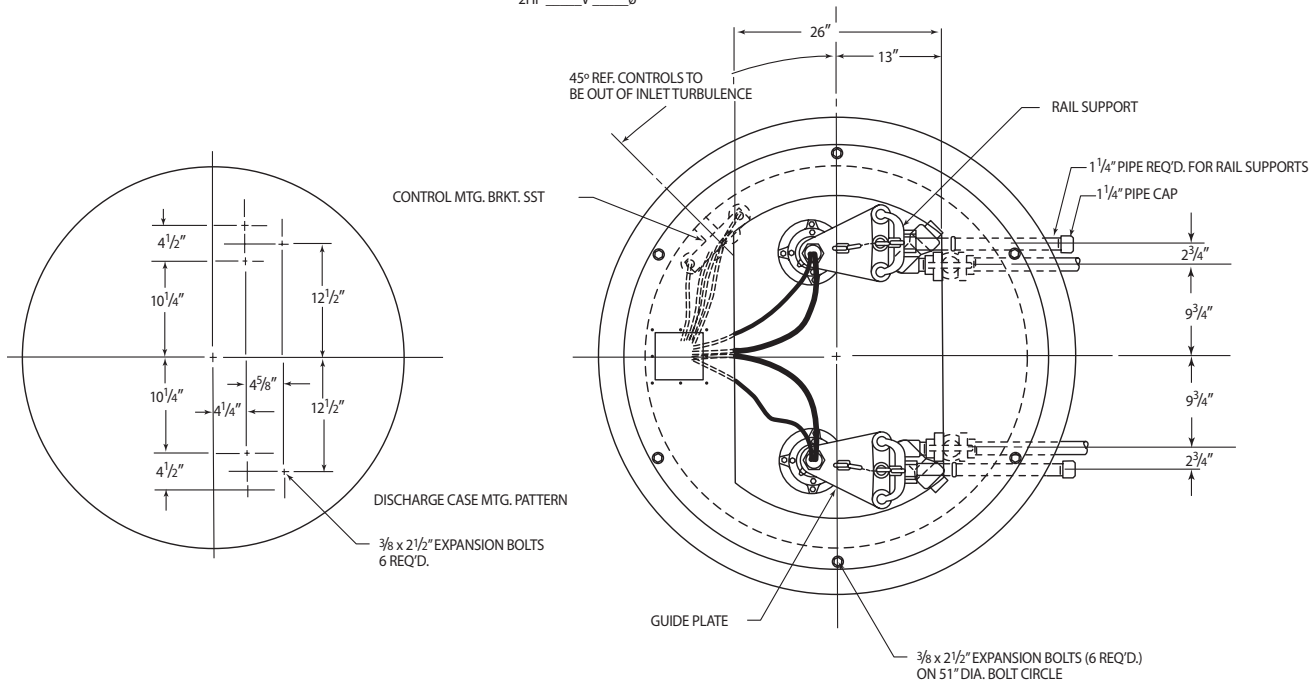
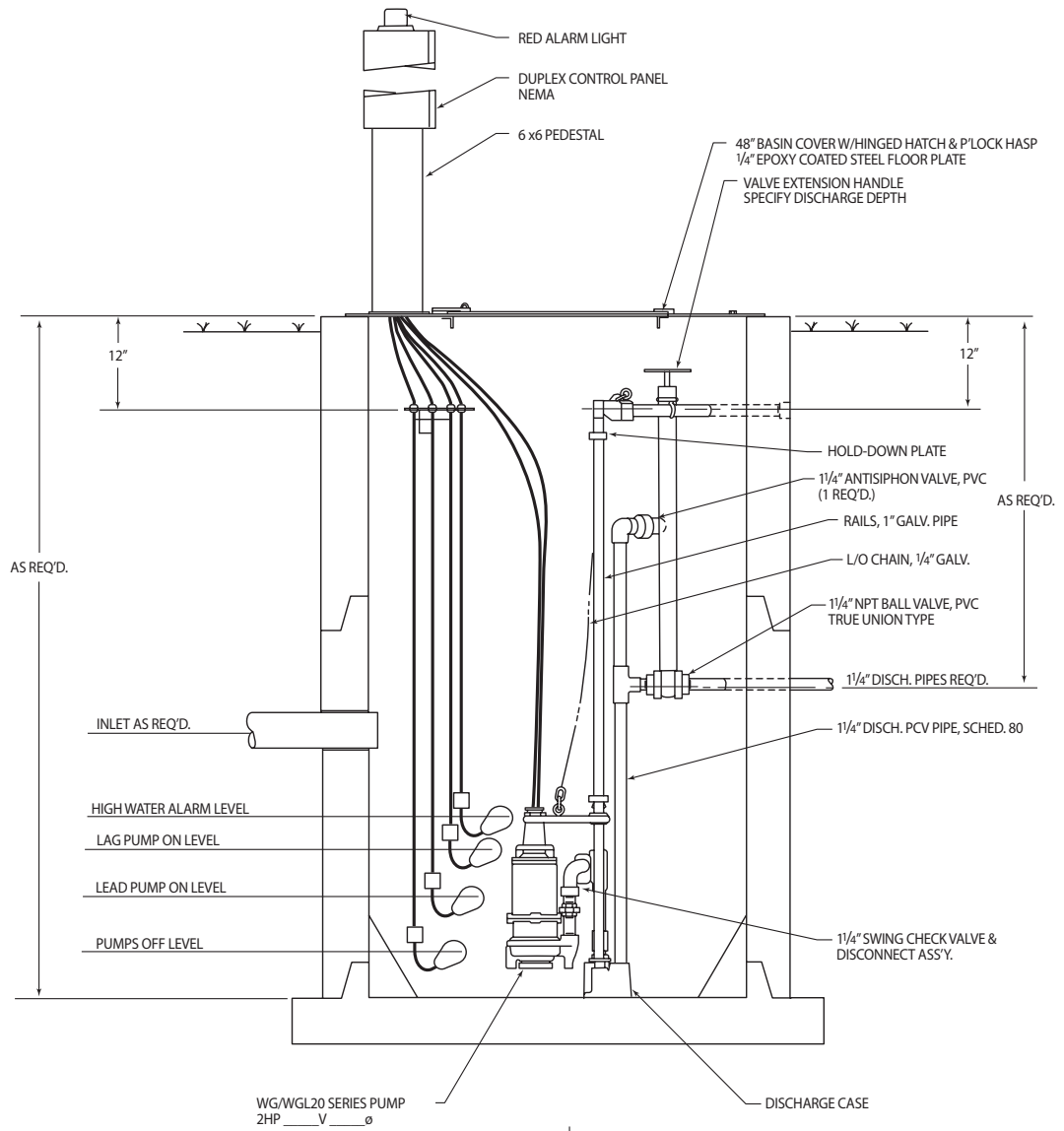

ASSEMBLING DISCHARGE PIPING AND RAIL GUIDES TO PUMP

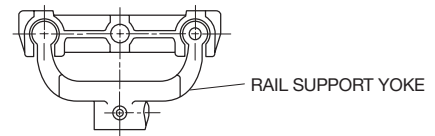

PIPING SETS AT ANGLE TO PUMP AS SHOWN

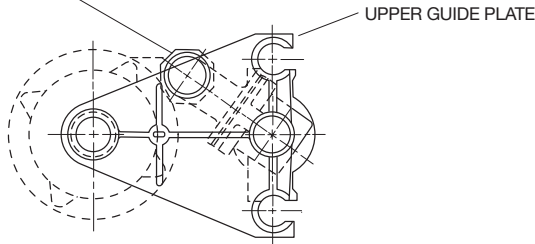

CONDUIT BUSHING
1 1/2" NIPPLE

UPPER GUIDE PLATE

STEPS TO CONNECT PIPING ASS'Y. AND RAIL GUIDES TO PUMP.

1. SCREW NIPPLE WITH HALF UNION INTO PUMP AND CONNECT TO PIPING. JUST TIGHTEN UNION SNUG.
2. SCREW 1 1/2" NIPPLE INTO CORD HOUSING CAP.
3. PLACE UPPER GUIDE PLATE OVER 1 1/2" NIPPLE AND TURN PLATE UNTIL 1" PIPE OPENING LINES WITH HOLE IN CHECK VALVE BODY.
4. INSERT 1" NIPPLE WITH CAP THROUGH EYE PLATE AND SCREW INTO VALVE BODY, TIGHTEN SET SCREWS IN GUIDE PLATE.
5. TIGHTEN UNION
6. IF LOWER RAIL GUIDE DOES NOT LINE WITH UPPER PLATE, TURN 1 1/2" DISCHARGE NIPPLE UNTIL GUIDE HOLES LINE UP.
7. SCREW CONDUIT BUSHING ONTO PUMP CORD NIPPLE.

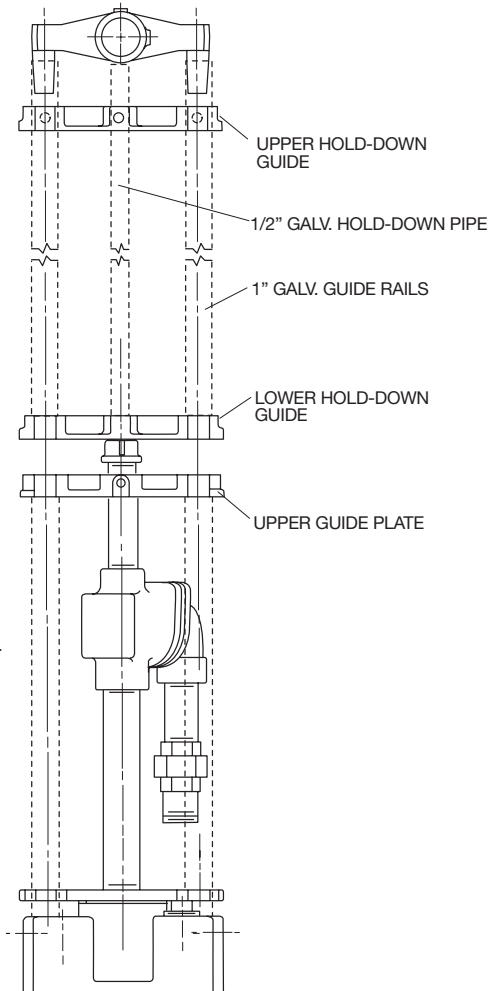
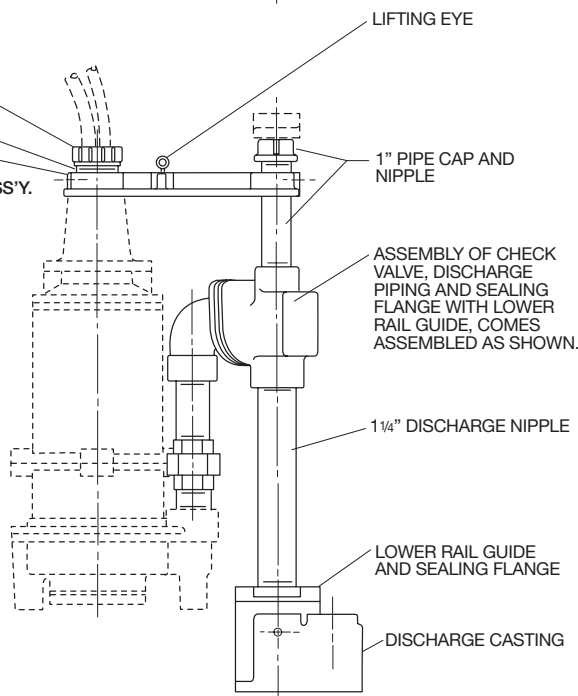

RWG & RWGX 125 RAIL SYSTEM PARTS LIST FOR 2HP GRINDER PUMPS

Ref. No.	Description	Qty.	Part Numbers	
			Standard RWG-125	Hazardous Location RWGX-125
1	BOLT EYE, GALV. 5/16-18 x 7/8 EYE	1	21929A001	21929A001
2	CLEVIS, CHAIN SHACKLE, GALV.	2	22417A001	22417A001
3	GUIDE, UPPER RAIL	1	22416B000	22416B000
4	SCREW, SET 3/8-16 UNC x 1, SQ. HD., SST	8	05057A030	05057A030
5	PLATE, TOP HOLD-DOWN	1	22415B001	22415B003
6	SCREW, CAP, HEX, SST, 3/8-16 x 1 LG.	2	19101A010	19101A010
7	SCREW, CAP, HEX, SST, 3/8-16 x 3/4 LG.	2	19101A003	19101A003
8	CHAIN	1	07741A012	07741A012
9	BOLT, EYE, GALV. 3/8-16 THD. x 1" EYE	1	21929A002	21929A002
10	PLATE, BOTTOM HOLD-DOWN	1	22415B000	22415B002
11	PLATE, UPPER GUIDE	1	22414C001	22414C002
12	VALVE, CHECK & FITTINGS	1	22412C000	22412C001
	SLEEVE, SEAL & GUIDE	1	22422C000	22422C001
	RING, O, 2-1/4 OD x 1-7/8 ID x 3/16	2	05876A036	05876A036
	PIPE, GALV. 1-1/4 x 10-1/2	1	05917A124	05917A124
	VALVE, CHECK 1-1/4	1	23076C002	23076C002
	PIPE, STEEL, GALV. 1-1/4 x 2	1	05917A051	05917A051
	UNION, PIPE	1	11387A008	11387A008
	PIPE, GALV. 1-1/4 x 3-3/4 LG.	1	05917A132	05917A132
	PIPE, GALV. 1 x 6	1	05427A052	05427A052
	CAP, PIPE, MALL GALV. 1"	1	05737A002	05737A002
13	CASE, DISCHARGE	1	22413D000	22413D000
14	PLUG, PIPE, GALV. 1-1/4 SQ. H.D.	2	05022A047	05022A047
	PIPE, GALV. 1-1/2 x 2-1/2	1	-	05347A026
	BUSHING, CONDUIT, 1-1/2 PIPE	1	-	21955A001
	PIPE, GALV. 1-1/4 x 4 TOE	1	07358A037	07358A037
	PIPE, GALV. 1-1/4 x 5 TOE	1	07358A040	07358A040
	PKG., DISCH. FLANGE CAT. DF 125-36	1	22428C010	22428C010

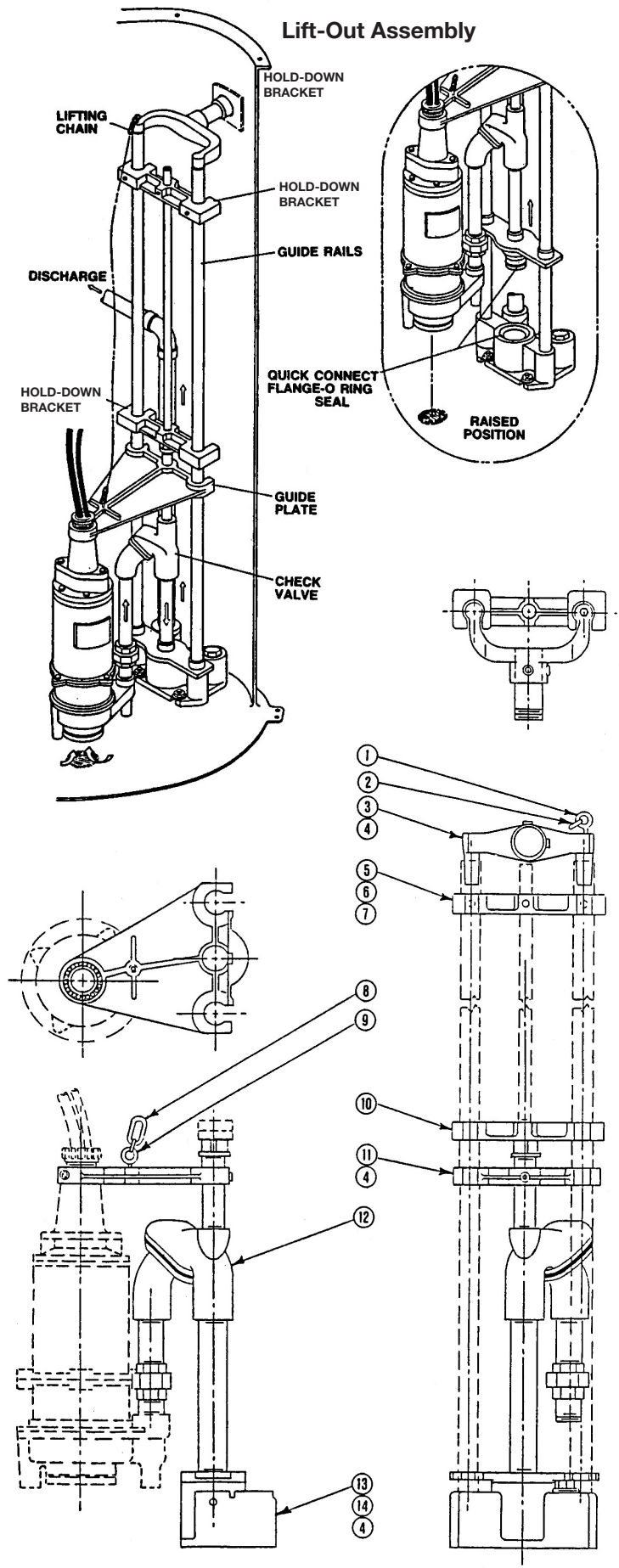

BOX CONNECTION, DUPLEX GRINDER SYSTEM ALC SWITCH AND FLC ALARM CONTROLS

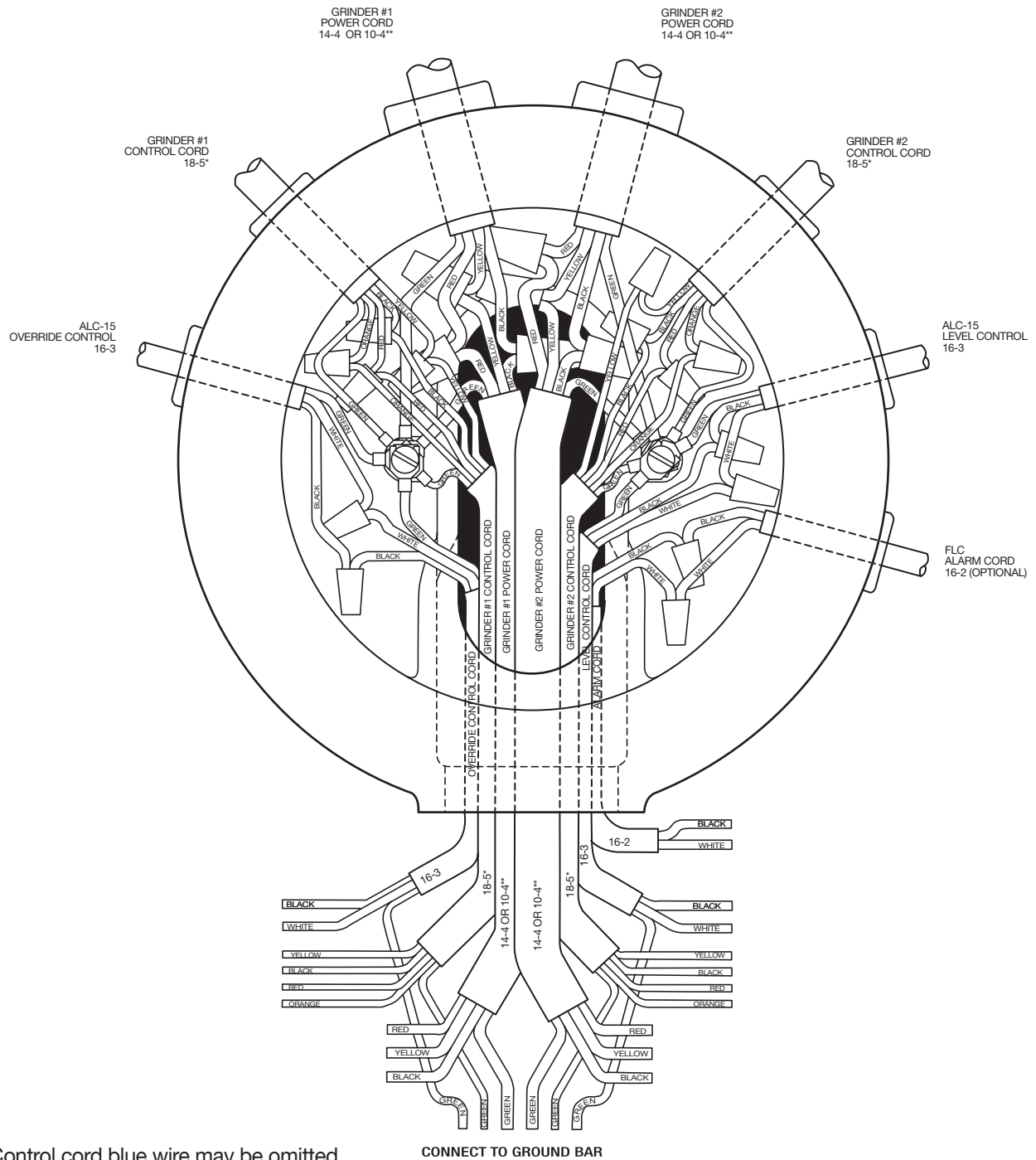

* Control cord blue wire may be omitted depending on production date of pump. If blue wire is used connect as shown, if not omit blue wire connections.

** Gauge depends on horsepower of pump.

CONNECTION BOX, DUPLEX GRINDER SYSTEM, FLCW 4 BALL CONTROL

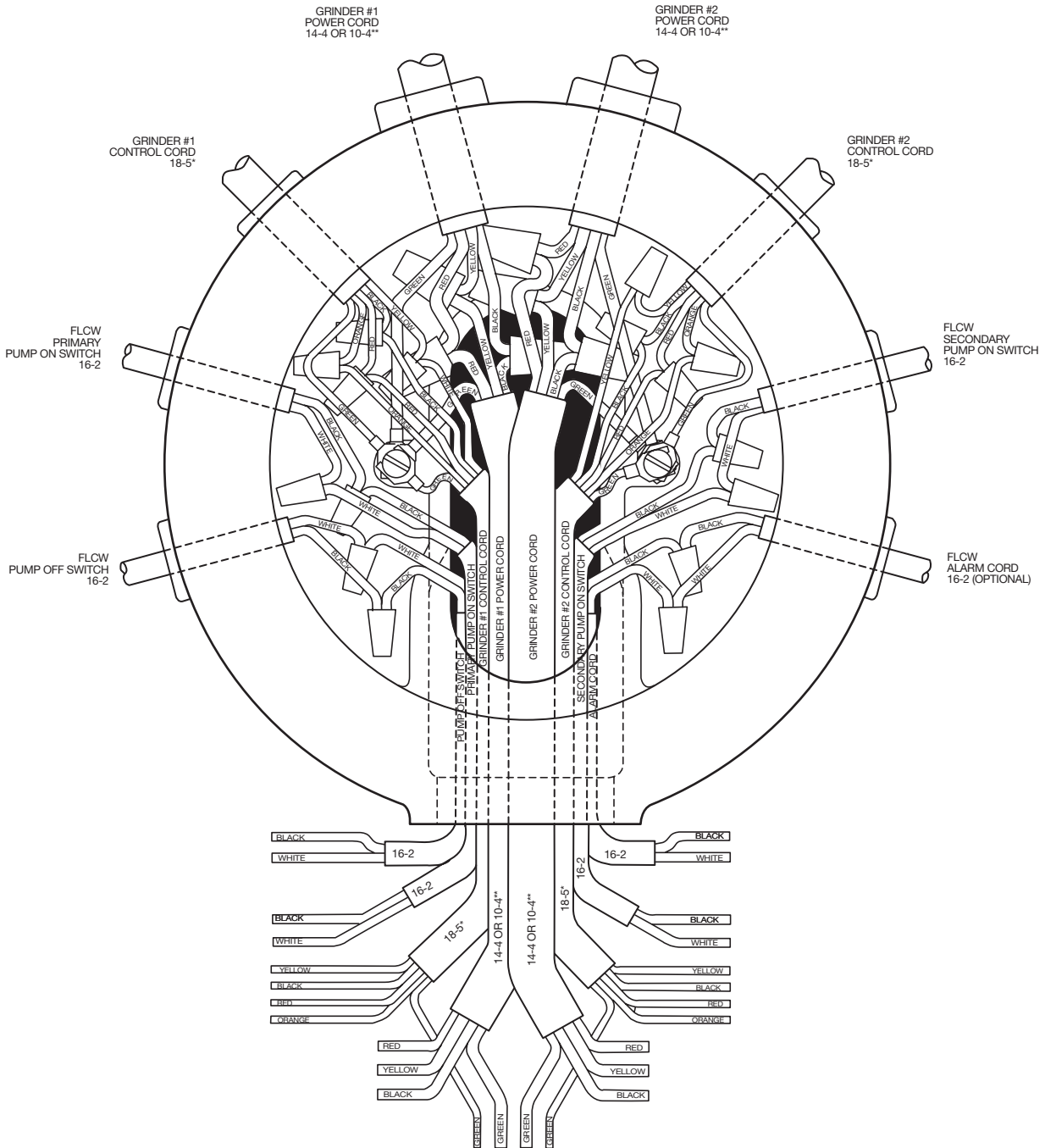

* Control cord blue wire may be omitted depending on production date of pump. If blue wire is used connect as shown, if not omit blue wire connections.

** Gauge depends on horsepower of pump.

STANDARD LIMITED WARRANTY

Pentair Myers® warrants its products against defects in material and workmanship for a period of 12 months from the date of shipment from Pentair Myers or 18 months from the manufacturing date, whichever occurs first – provided that such products are used in compliance with the requirements of the Pentair Myers catalog and technical manuals for use in pumping raw sewage, municipal wastewater or similar, abrasive-free, noncorrosive liquids.

During the warranty period and subject to the conditions set forth, Pentair Myers, at its discretion, will repair or replace to the original user, the parts that prove defective in materials and workmanship. Pentair Myers reserves the right to change or improve its products or any portions thereof without being obligated to provide such a change or improvement for prior sold and/or shipped units.

Start-up reports and electrical schematics may be required to support warranty claims. Submit at the time of start-up through the Pentair Myers website: <http://forms.pentairliterature.com/startupform/startupform.asp?type=m>. Warranty is effective only if Pentair Myers authorized control panels are used. All seal fail and heat sensing devices must be hooked up, functional and monitored or this warranty will be void. Pentair Myers will cover only the lower seal and labor thereof for all dual seal pumps. Under no circumstance will Pentair Myers be responsible for the cost of field labor, travel expenses, rented equipment, removal/reinstallation costs or freight expenses to and from the factory or an authorized Pentair Myers service facility.

This limited warranty will not apply: (a) to defects or malfunctions resulting from failure to properly install, operate or maintain the unit in accordance with the printed instructions provided; (b) to failures resulting from abuse, accident or negligence; (c) to normal maintenance services and parts used in connection with such service; (d) to units that are not installed in accordance with applicable local codes, ordinances and good trade practices; (e) if the unit is moved from its original installation location; (f) if unit is used for purposes other than for what it is designed and manufactured; (g) to any unit that has been repaired or altered by anyone other than Pentair Myers or an authorized Pentair Myers service provider; (h) to any unit that has been repaired using non factory specified/OEM parts.

Warranty Exclusions: PENTAIR MYERS MAKES NO EXPRESS OR IMPLIED WARRANTIES THAT EXTEND BEYOND THE DESCRIPTION ON THE FACE HEREOF. PENTAIR MYERS SPECIFICALLY DISCLAIMS THE IMPLIED WARRANTIES OF MERCHANTABILITY AND FITNESS FOR ANY PARTICULAR PURPOSE.

Liability Limitation: IN NO EVENT SHALL PENTAIR MYERS BE LIABLE OR RESPONSIBLE FOR CONSEQUENTIAL, INCIDENTAL OR SPECIAL DAMAGES RESULTING FROM OR RELATED IN ANY MANNER TO ANY PENTAIR MYERS PRODUCT OR PARTS THEREOF. PERSONAL INJURY AND/OR PROPERTY DAMAGE MAY RESULT FROM IMPROPER INSTALLATION. PENTAIR MYERS DISCLAIMS ALL LIABILITY, INCLUDING LIABILITY UNDER THIS WARRANTY, FOR IMPROPER INSTALLATION. PENTAIR MYERS RECOMMENDS INSTALLATION BY PROFESSIONALS.

Some states do not permit some or all of the above warranty limitations or the exclusion or limitation of incidental or consequential damages and therefore such limitations may not apply to you. No warranties or representations at any time made by any representatives of Pentair Myers shall vary or expand the provision hereof.



MYERS®

1101 MYERS PARKWAY
ASHLAND, OHIO, USA 44805
419-289-1144

490 PINEBUSH ROAD, UNIT #4
CAMBRIDGE, ONTARIO, CANADA N1T 0A5
800-363-PUMP

WWW.FEMYERS.COM

Warranty Rev. 12/13