

 Applies To: **See VEHICLES AFFECTED**
February 17, 2011

Chirp From the Timing Belt Area

(Supersedes 08-045, dated May 21, 2010, to revise the information marked by the black bars)

REVISION SUMMARY

Under REPAIR PROCEDURE, step 8, a note about inspecting the timing belt auto-tensioner was added.

SYMPTOM

There is a chirp coming from the lower timing belt area. The noise is most often noticed at idle, usually after the engine has warmed up.

PROBABLE CAUSE

The idler pulley mounting surface is tilted, causing the edge of the timing belt to rub against the side of the pulser flange on the drive pulley (gear).

VEHICLES AFFECTED

2005–07 Accord V6 – ALL

2008 Accord 2-Door V6 with A/T –

From VIN 1HGCS2...8A000001 thru
1HGCS2...8A005943

2008 Accord 4-Door V6 with A/T –

From VIN 1HGCP3...8A000001 thru
1HGCP3...8A032544

2008 Accord V6 M/T – ALL

2009 Accord V6 M/T –

From VIN 1HGCS2...9A000001 thru
1HGCS2...9A002647

2005–08 Odyssey – ALL

2009 Odyssey –

From VIN 5FNRL3...9B000001 thru
5FNRL3...9B057721

From VIN 5FNRL3...9B400001
5FNRL3...9B411326

2005–09 Pilot – ALL

2010 Pilot 2WD –

From VIN 5FNYP3...AB000001 thru
5FNYP3...AB002381

2010 Pilot 4WD –

From VIN 5FNYP4...AB000001 thru
5FNYP4...AB003614

2006–08 Ridgeline – ALL

2009 Ridgeline –

From VIN 2HJYK1...9H500001 thru
2HJYK1...9H503152

From VIN 5FPYK1...9B100001 thru
5FPYK1...9B104340

CORRECTIVE ACTION

Install a taper shim kit, and grind a deeper relief on the engine mount bracket if needed.

These 2007 Accord V6 vehicles also require water pump replacement:

2-Door with M/T –

From VIN 1HGCM8...7A002002 thru
1HGCM8...7A004104

2-Door with A/T –

From VIN 1HGCM8...7A002029 thru
1HGCM8...7A003983

4-Door with M/T –

From VIN 1HGCM6...7A037354 thru
1HGCM6...7A060259

4-Door with A/T –

From VIN 1HGCM6...7A034807 thru
1HGCM6...7A057992

PARTS INFORMATION

Taper Shim Kit:

2005 models: P/N 04148-RCA-305

2006–10 models:

P/N 04148-RCA-306

(Contains taper shim, timing belt, and timing belt drive pulley [gear]).

Water Pump (2007 Accord V6 only):

P/N 19200-RDM-A02

REQUIRED MATERIALS

Hondalock 1 (one container repairs about 10 vehicles):

P/N 08713-0001

WARRANTY CLAIM INFORMATION

The normal warranty applies.

OP#	Description	FRT
1110A2	With Water Pump: Install a taper shim kit and a water pump, and grind a relief on the engine mount bracket, if needed. Includes time to do the CKP Pattern Clear/Learn.	3.0
1110A3	Without Water Pump: Install a taper shim kit, and grind a relief on the engine mount bracket, if needed. Includes time to do the CKP Pattern Clear/Learn.	2.6

Failed Part: P/N 15100-RCA-A03

Defect Code: 07403

Symptom Code: 04201

Skill Level: Repair Technician

DIAGNOSIS

NOTE: If you are viewing this service bulletin on ISIS and your computer has sound, click on **Click to Play** to hear an example of the noise.



1. Remove the drive belt:
 - Refer to Section 4 of the appropriate service manual, or
 - Online, enter keywords **DRIVE BELT**, and select the appropriate engine's **Drive Belt Replacement** from the list.
2. Start the engine.

Do you still hear the noise?

Yes – Go to REPAIR PROCEDURE.

No – Reinstall the drive belt, then continue with normal troubleshooting procedures.

REPAIR PROCEDURE

NOTE: On certain 2007 Accord V6 vehicles, you will also be replacing the water pump (see **CORRECTIVE ACTION**). All other non-water pump replacement steps apply to all affected vehicles.

1. *Affected 2007 Accord V6 only:* Drain the engine coolant into a clean container, and save it for reuse:
 - Refer to page 10-6 of the *2003–07 Accord V6 Service Manual Supplement*, or
 - Online, enter keyword **COOLANT**, and select **Coolant Replacement (V6 engine)** from the list.
2. Set the engine to TDC (top dead center).
3. Remove the crankshaft pulley:
 - Refer to Section 6 of the appropriate service manual, or
 - Online, enter keyword **PULLEY**, and select **Crankshaft Pulley Removal and Installation** from the list.

4. Remove the timing belt covers:
 - Refer to Section 6 of the appropriate service manual, or,
 - Online, enter keywords **TIMING BELT**, and select **Timing Belt Removal** from the list.
5. Try to insert a 0.95 mm feeler gauge between the top edge of the timing belt idler pulley and the back of the side engine mount bracket overhanging the pulley. This measurement is used to determine if step 12 is required.

NOTE: Remove the feeler gauge from its holder to get a more accurate measurement.

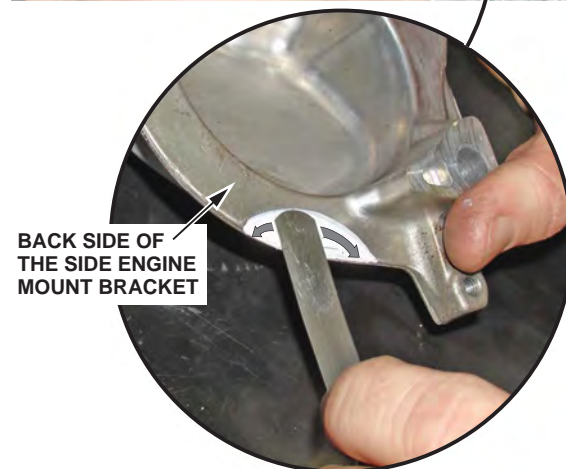
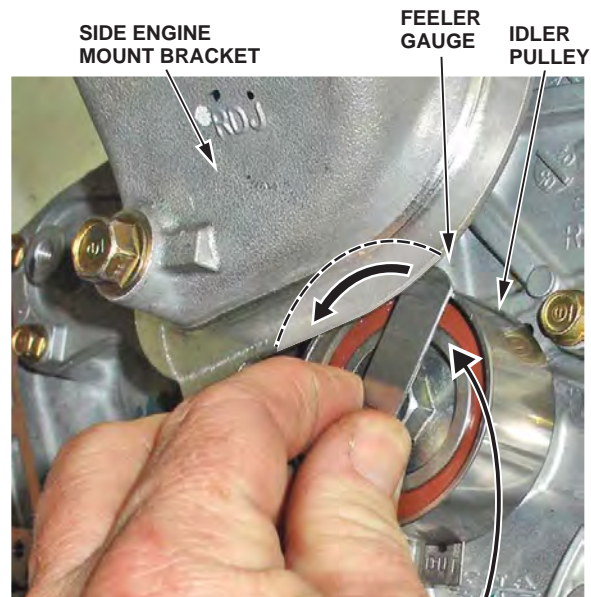

6. Unbolt the CKP (crankshaft position) sensor (if applicable), and set it aside. Do not disconnect the CKP harness connector.
7. Remove the engine mount bracket.

8. Remove the timing belt.

NOTE: Remove the timing belt auto-tensioner, and inspect the tip of the piston for signs of damage. Test the tensioner by pushing it down against a flat surface. The tensioner should not compress. Replace it if it is damaged or if it compresses.

GOOD TENSIONER

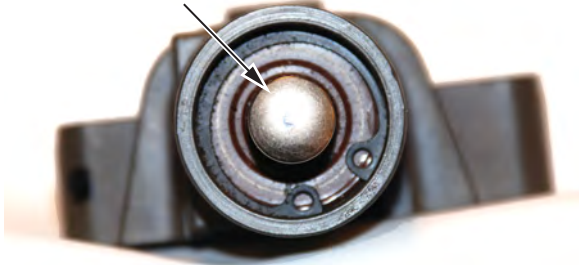

BAD TENSIONER

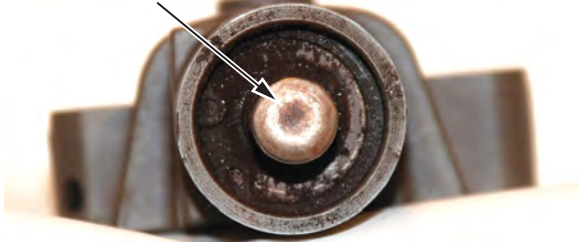

9. *Affected 2007 Accord V6 only:* Remove the timing belt adjuster.
10. *Affected 2007 Accord V6 only:* Remove the water pump.
11. Remove the timing belt idler pulley.

12. If the feeler gauge fit in step 5, go to step 13. If the feeler gauge did not fit in step 5, remove the side engine mount bracket. Using a die grinder with a 2-inch, 50-grit grinding disc (or equivalent) and the circular casting offset as a guide, grind the side engine mount bracket until the lip measures 2 mm thick with a caliper or a micrometer.

**BACK SIDE OF THE
SIDE ENGINE MOUNT BRACKET**



13. *Affected 2007 Accord V6 only:* Replace the water pump, and reuse the coolant you removed in step 1:
- Refer to page 10-5 of the *2003–07 Accord V6 Service Manual Supplement*, or
 - Online, enter keyword **WATER**, and select **Water Pump Replacement (V6 engine)** from the list.
14. *Affected 2007 Accord V6 only:* Reinstall the timing belt adjuster.

15. Place the idler pulley shim between the idler pulley and the oil pump housing, and loosely install the idler pulley bolt with Hondalock 1 applied to its threads. Make sure to follow the assembly instructions on the Hondalock 1 container.

NOTE: The shim tapers from left to right. The word "OUT" is painted in white and stamped into the tang of the shim, and should be readable when the shim is installed.

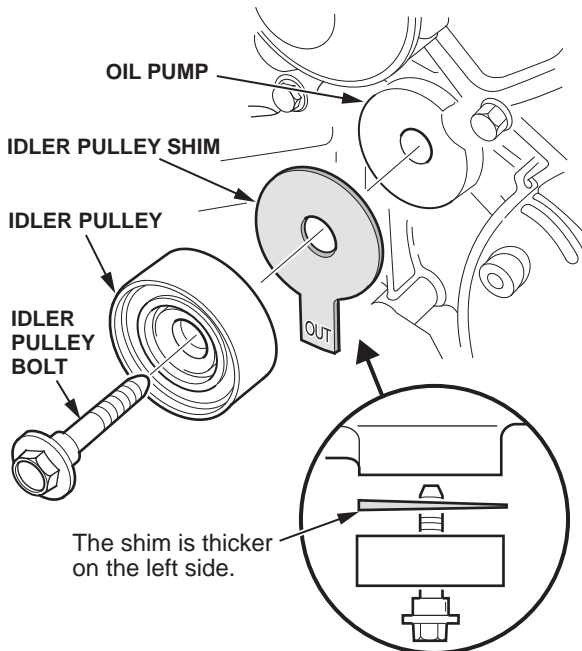

16. When tightening the idler pulley bolt, use the square end of a 1/4 inch drive ratchet extension to keep the shim's tab in the correct position. After you torque the idler pulley bolt to **44 N·m (33 lb-ft)**, bend the shim's tab slightly towards the oil pump housing to keep it away from the idler pulley.

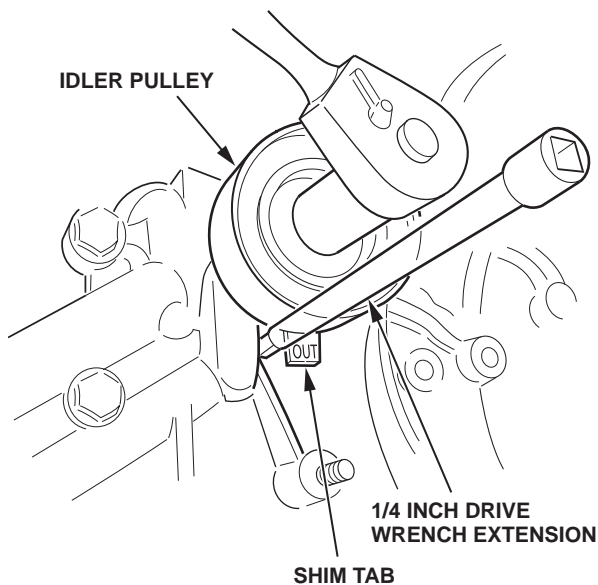

17. Install a new timing belt drive pulley (gear):

- Refer to Section 6 of the appropriate service manual, or
- Online, enter keywords **TIMING BELT**, and select **Timing Belt Drive Pulley Replacement** from the list.

18. Install a new timing belt:

NOTE: Use the (new belt) Timing Belt Replacement Procedure, not the (used belt) Timing Belt Installation Procedure.

- Refer to Section 6 of the appropriate service manual, or
- Online, enter keywords **TIMING BELT**, and select **Timing Belt Replacement** from the list.

19. Reinstall the CKP sensor (if applicable), and torque its bolt to **9.8 N·m (7.2 lb-ft)**.

20. Reassemble the remaining parts using the appropriate service manual procedures. If you replaced the water pump, make sure you bleed any air from the cooling system after refilling with the coolant you drained in step 1.

21. Do the CKP pattern clear/CKP pattern learn procedure. Go to the appropriate procedure below.

NOTE: If you don't do the CKP pattern clear/learn procedure, the ECM/PCM may detect misfire when there is none, and possibly set DTC(s) P0300 through P0306.

CKP Pattern Clear/Learn Procedure

2005–06 Odyssey

2005 Pilot

NOTE:

- The ECT must be at least 176 degrees F (80 degrees C).
- *2005 Pilot only:* Before doing this procedure, check "PULSER F/B LEARN" and "PULSER F/B LEARN (HIGH RPM)" in the DATA LIST with the HDS. If both values show N/A, this procedure is not needed.
- *2005 Pilot only:* If only "PULSER F/B LEARN (HIGH RPM)" shows N/A, skip steps 7 through 9.

1. With the engine stopped, clear the CKP pattern.
2. Turn the ignition switch to LOCK (0).
3. Turn the ignition switch to ON (II), and wait 30 seconds.
4. Test-drive the vehicle on a level road: decelerate with the throttle fully closed from an engine speed of 2,500 rpm to 1,000 rpm with the A/T in 2.
5. Stop the vehicle, but keep the engine running.
6. Check PULSER F/B LEARN in the DATA LIST with the HDS. If it is NOT COMPLETED, go to step 4. If it is COMPLETED, go to step 7.

7. Test-drive the vehicle on a level road: decelerate with the throttle fully closed from an engine speed of 5,000 rpm to 3,000 rpm with the A/T in 2.
8. Stop the vehicle, but keep the engine running.
9. Check the PULSER F/B LEARN (HIGH RPM) in the DATA LIST with the HDS. If it is NOT COMPLETED, go to step 7. If it is COMPLETED, go to step 10.
10. Turn the ignition switch to LOCK (0).
11. Turn the ignition switch to ON (II), and wait 30 seconds. The CKP learning procedure is complete.

2005–09 Accord

2007–09 Odyssey

2006–10 Pilot

2006–09 Ridgeline

1. Connect the HDS to the data link connector (DLC) located under the driver's side of the dashboard.
2. Turn the ignition switch to ON (II).
3. Make sure the HDS communicates with the ECM/PCM. If it does not, go to the DLC circuit troubleshooting.
4. Select CRANK PATTERN in the ADJUSTMENT MENU with the HDS.
5. Select CRANK PATTERN LEARNING with the HDS, and follow the screen prompts.