

# Troubleshooting Manual

## Inverter Split Wall mounted Type L-Series

### Heat pump:

Indoor unit: FTXN-LV

Outdoor unit: RXN-LV

---

# 1.0 Introduction

Inverter Air conditioning technology is today's solution for superior comfort, higher efficiency and better energy saving. Daikin Inverter included Residential, Light Commercial and Multi Split Unit.

INVERTER Y SINGLE SPLIT (Residential, Light Commercial)

- i) INDOORS
- ii) OUTDOORS

## 1.1 INVERTER Y SINGLE SPLIT

Residential (FTXN-LV & RXN-LV):

- High Quality & Efficiency Daikin DC Inverter compressor
- High Performance Daikin Inverter Controller
- 5-speed Step-less Fan operation
- BioPro IAQ.
- New Inverter-only Remote Control

Piping Length & Elevation

Model	Max. total piping length (m)	Max. height difference (m)	Pre-charge for up to piping length (m)	Additional charge (g/m)
RXN25LV1B	20	10	7.5	20
RXN30LV1B	20	10	7.5	20
RXN50LV1B	30	10	7.5	20
RXN60LV1B	30	10	7.5	20

Terminal Block for outdoor:

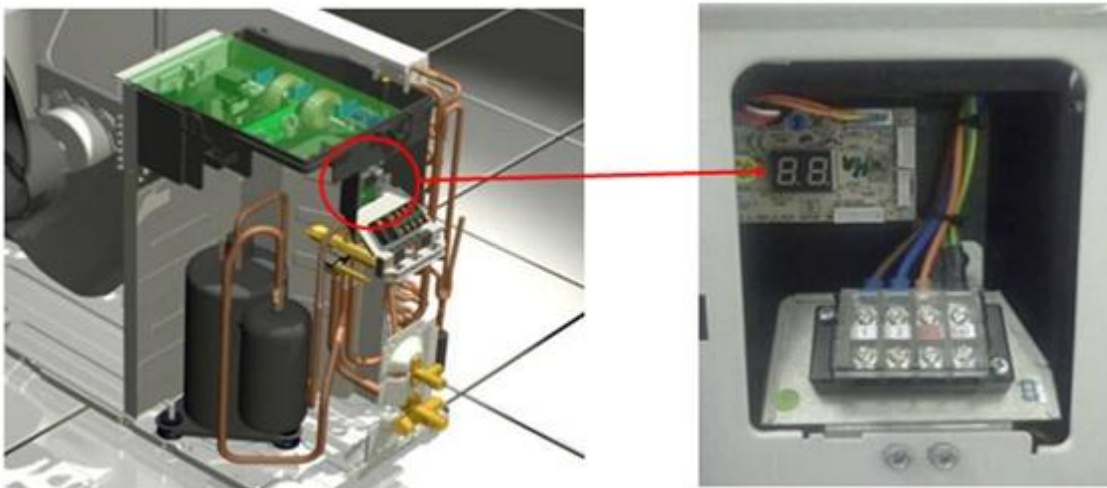

- Equipped with 7-segment display to improve serviceability. (Exclude for RXN25/30LV1B)
- To retrieve error code & running parameters.

Disable Auto Random Restart function:



Series I

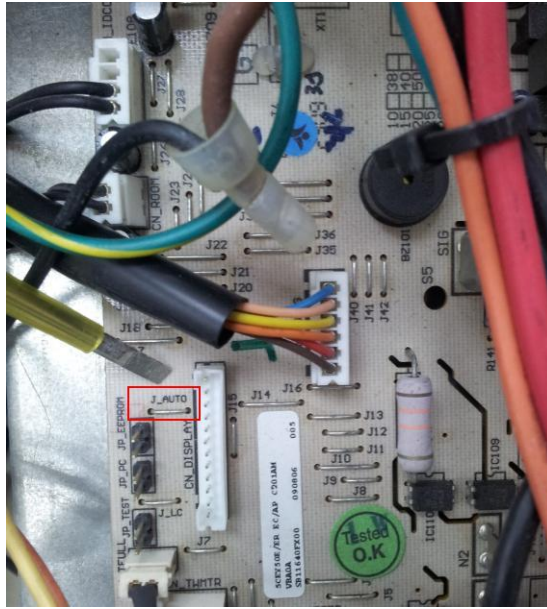

Series II

To disable the auto random restart function, kindly cut off the jumper J\_AUTO as highlighted in attachment.

Please be informed that after disable auto random restart, unit is not able to restart with last state memory after power resume from failure. Unit will revert to default setting as below:

Default setting

Unit: Off

Temperature: 24°C

Fan speed: High

Mode: Cooling

---

## 2.0 Algorithm and Control

### INDOOR BASIC FUNCTIONS

#### Residential and Light Commercial

- The system has 5 operating modes. The mode selection is done from indoor using handset.
- The operating modes are:
  - Cool
  - Heat
  - Fan
  - Auto
  - Dry

#### Cool Mode:

- When  $Tr \geq Ts - 1.5^{\circ}\text{C}$ 
  - Comp, Indoor Fan and Outdoor Fan ON.
- When  $Tr \leq Ts - 2^{\circ}\text{C}$ 
  - Compressor and Outdoor Fan OFF.
  - Indoor Fan remains ON.

Tr = Room Temperature

Ts = Set Temperature

When cooling load is too small and the room temperature still falling below compressor cut off point, compressor will stop.

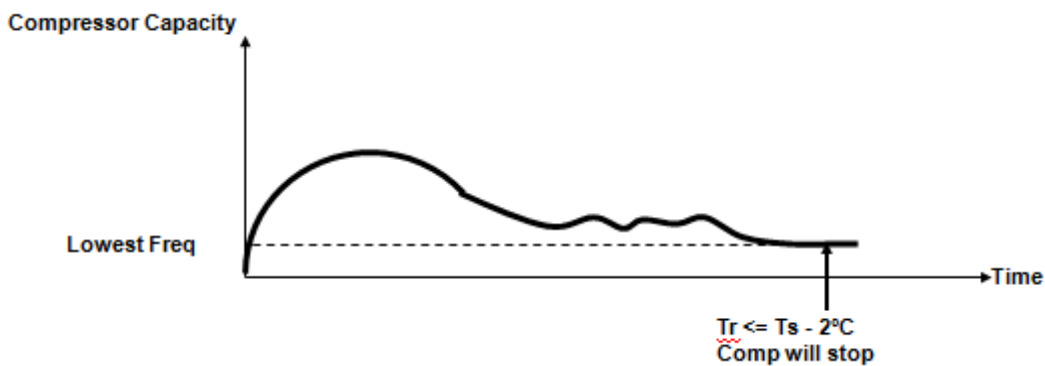

---

### Heat Mode:

- When  $T_s > T_r - 1.0^\circ\text{C}$ 
  - Comp, ID Fan and OD Fan ON.
- When  $T_r \geq T_s + 1.5^\circ\text{C}$ 
  - Compressor and Outdoor Fan OFF.
  - Indoor Fan off if indoor coil  $\leq 20^\circ\text{C}$ .

$T_r$  = Room Temperature

$T_s$  = Set Temperature

When heating load is too small, and the room temperature still rising above compressor cut off point, compressor will stop.

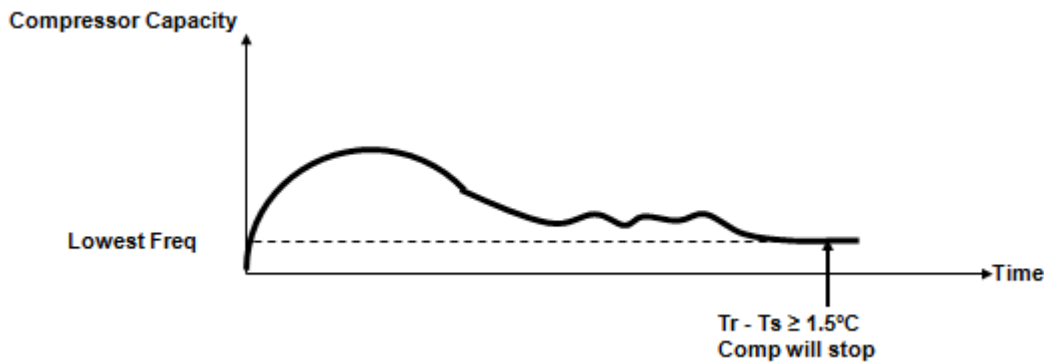

### FAN MODE

- Only High, Medium and Low fan speeds are allowed.
- When changing cool mode to fan mode, the compressor will stop and OD fan stops based on fan OFF control.
- Compressor only ON if the minimum stop time is  $> 3$  minutes and the user change back to cool mode.
- Fan speed will maintain same as during fan mode.

### AUTO MODE

- For heat pump only
- Mode switching point:
  - Heating  $\rightarrow$  Cooling
    - $T_r \geq T_s + 2.5$
  - Cooling  $\rightarrow$  Heating
    - $T_r \leq T_s - 2.5$
- During initial operation
  - Cooling operation:  $T_r > T_s$
  - Heating operation:  $T_r < T_s$

---

## ID-OD COMMUNICATION

- Master by outdoor unit.
- Indoor controller board will transmit signal to outdoor controller board every 0.5s. Outdoor unit will response to indoor once the valid data is received.

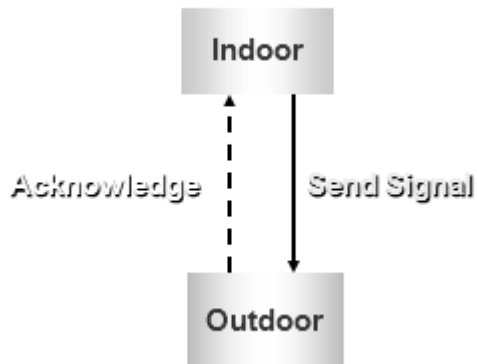

- If the data communication line between indoor and outdoor disrupted for 15s continuously, compressor will stop, OD fan stop with fan OFF timer. ID LED blinks error.
- If the communication resumes within 15s, error code is clear and compressor restarts after 3 minutes.
- If the communication does not resume after 15s, unit unable to restart and the error keep blinking.

## THERMISTORS IN RXN-LV

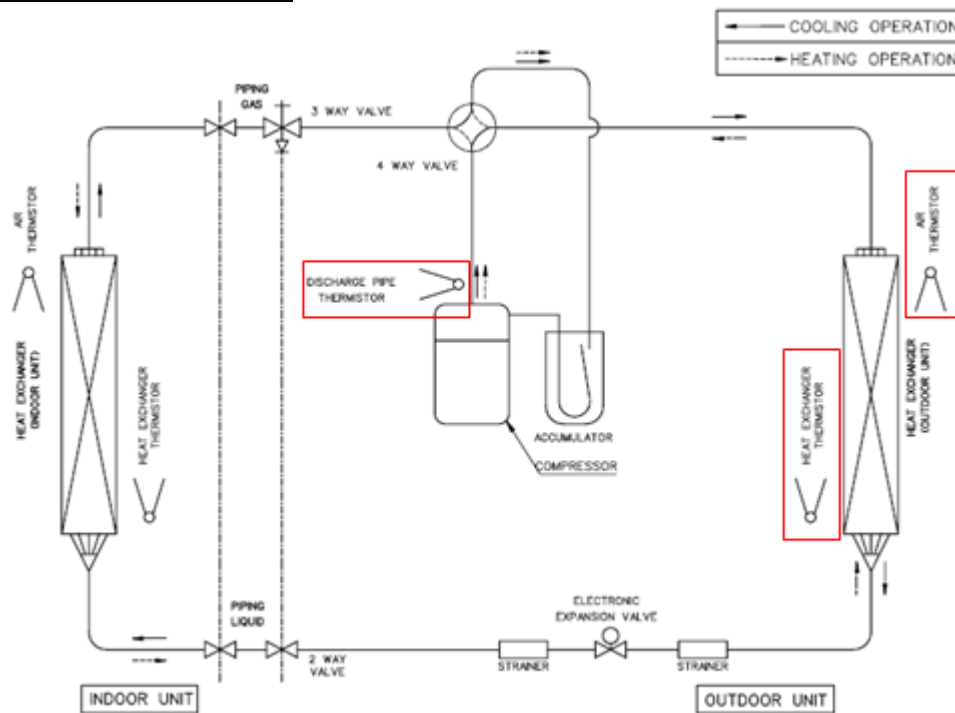

## FUNCTIONS OF THERMISTOR

Thermistor	Functions
Discharge pipe	Used for discharge superheat (SH) & EXV control. Also used for crankcase heater/ preheating control in Series 2 model.
Outdoor coil	Used for defrost control. Also used for inverter current protection control in Series II.
Outdoor air	Used for defrost & outdoor fan speed control. Also used for PMV, overall current protection & preheating operation control.
Heat sink	Used for capturing heat sink temperature.
Suction pipe	Used for EXV (SH) & suction pipe SH protection control in heating.
Gas pipe	Used for gas pipe isothermal control in cooling. EXV opening is controlled so that accurate cooling capacity is achieved in each room.
Liquid pipe	Used for sub-cooling control in heating. Actual sub-cooling will be calculated with liquid pipe & max. heat exchanger temperature among all rooms. EXV opening is then adjusted to reach the target sub-cooling.

---

### MINIMUM RUN CONTROL

To prevent frequent compressor ON/OFF & to allow pressure equalization

- The compressor will be on 3 minutes stand-by after turning OFF before it is allowed to turn ON.
- OD fan OFF delay to improve pressure equalization & to prevent refrigerant from entering into evaporator.

### AUTO RESTART

- Factory pre-set.
- Allow unit to automatically resume the same operating mode it was in before a power failure.

### 4-WAY VALVE CONTROL

- Change over switching is only carried out during operation.
- OFF delayed is applied when the coil switches from ON to OFF, i.e. A5LCY Series I - 45 second,

Operating mode	4-way valve is
Heat, except for defrost	ON
Cool Dry Defrost	OFF

### DEFROST CYCLE

During defrost	RXN-LV
Compressor	ON
4-way valve	OFF
EXV in operation room	Fixed opening
EXV in operation stop room	-
Outdoor fan	OFF
Indoor fan	OFF



---

## FTXN-LV and RXN-LV:

### DEFROST CONTROL

- Condition for entering defrost
  - Compressor minimum run time – 6 minutes OR
  - Compressor accumulated run time of 45 minutes if OD coil < 3°C.
  - When OD coil < 0°C AND OD coil < OD air - 10°C.
- Condition for terminating defrost
  - OD coil > 12°C or
  - Total defrost timer of 650 seconds.

### OUTDOOR FAN CONTROL

- Determine from
  - Compressor target rotation: higher fan speed with higher rotation.
  - Outdoor air temperature.
- Cool mode: Higher fan speed with higher outdoor air temperature.
- Heat mode: Higher fan speed with lower outdoor air temperature.
- When compressor stops, fan OFF delay 30 seconds is carried out

### INDOOR COIL FREEZE PREVENTION

- Only available in cooling mode.
- When the indoor coil temperature < 2°C, the compressor starts to drop the frequency.
- This protection will cut in when:
  - Indoor coil temperature < 0°C for more than 180s. Compressor will stop, OD fan stop after 30s and indoor fan can only run at lowest fan speed.
- The unit can only be restarted after 3 minutes.
- When the indoor coil temperature > 13°C, the compressor frequency will be reset based on the OD ambient, room and set temperature.

ROTATION REGULATING FUNCTIONS

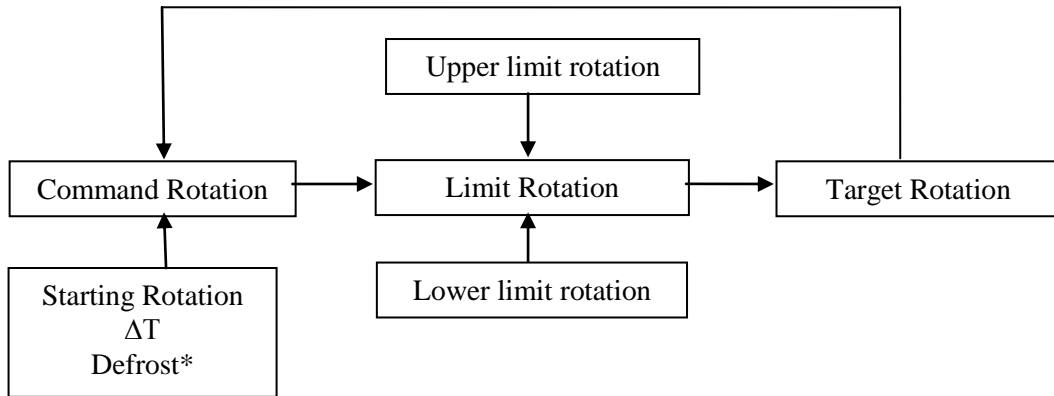

\* Defrost control for heat pump model only

STARTING ROTATION

STARTING CONTROL

- To avoid excessive oil discharge from compressor or to promote oil lubrication during startup.
- To prevent liquid flood back to the compressor.
- To limit starting current.
- When compressor starts to rotate from OFF to ON, compressor rotation is set to run gradually to each upper limit at a specific timer setting.

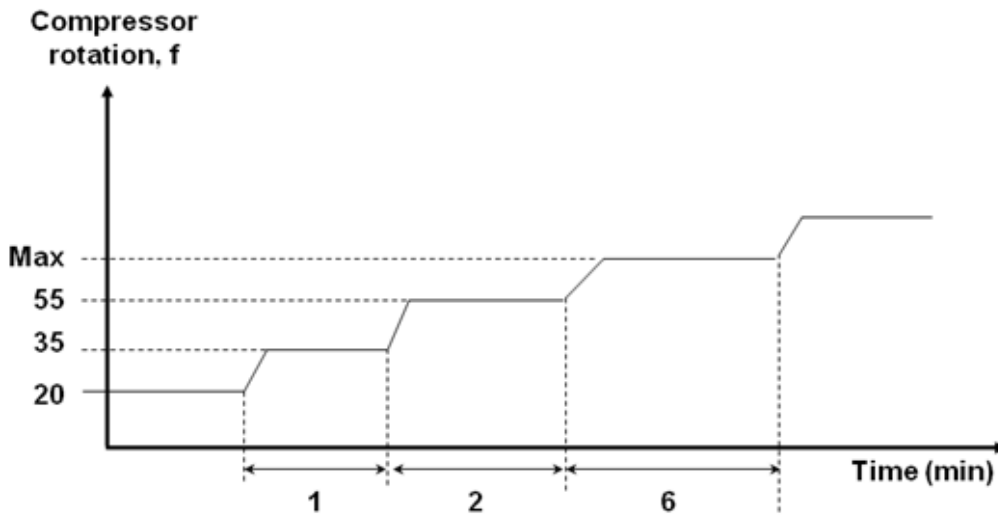

Model	Max. f
RXN25LV1B	68 Hz
RXN35LV1B	74 Hz
RXN50LV1B	90 Hz

---

RXN60LV1B	93 Hz
-----------	-------

## COMMAND ROTATION

- Cut in upon termination of Starting Control.
- Achieve capacity control by controlling the compressor rotation based on :
  - Temperature difference between set and room temperature,  $\Delta T$ .
  - Limit Rotation.
  - Defrost control.

## Fuzzy Control

- Based on temperature difference,  $\Delta T$ , current fan speed setting & current indoor operating mode at every 30 seconds interval.
- 

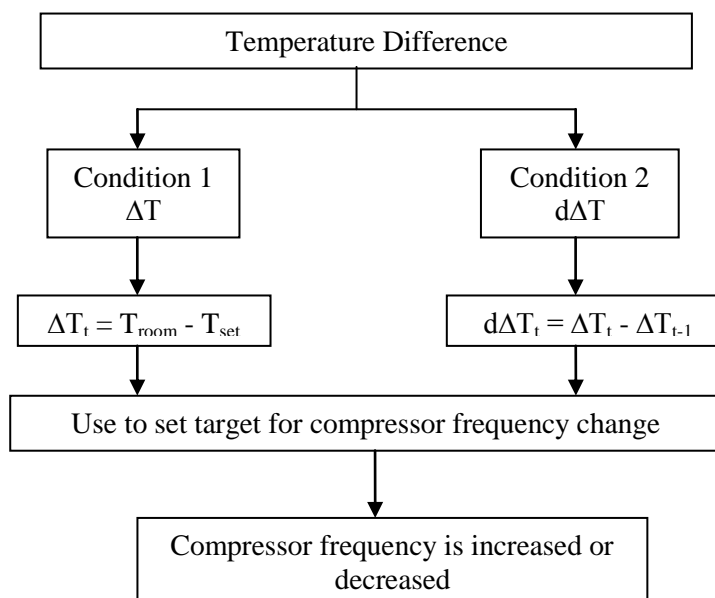

## LIMIT ROTATION

Determine from

- Upper limit rotation

A minimum value was determined among the upper limits rotation, i.e. protection controls.

- Lower limit rotation

A maximum value was determined among the lower limits rotation, i.e. protection controls.

Generally, compressor rotation is controlled within 4 zones: stop, drop, keep, up and reset subjected to a particular operating temperature/current/pressure.

Zone	Control
Stop	Compressor is stopped when a certain limit reaches the stop zone for abnormality correction.
Drop	Frequency will be dropped with a timer setting.
Keep	Frequency is maintained at lower/upper limit.
Up	Frequency will be increased with a timer setting.
Reset	Frequency lower/upper limit is canceled and returned to command rotation.

### HIGH PRESSURE PROTECTION

- To prevent high pressure in the system.
- Compressor operating frequency is adjusted based on upper limit of coil temperature (RXN-LV)

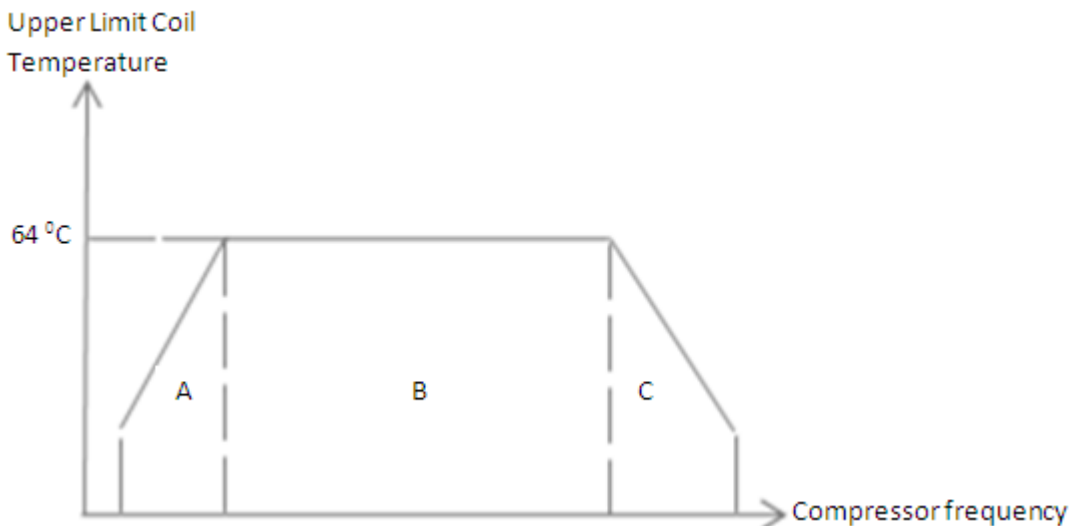

- The compressor frequency is adjusted based on coil temperature:
  - During cooling mode – outdoor coil temperature.
  - During heating mode – indoor coil temperature.
- This protection is activated when the coil temperature  $> 64^{\circ}\text{C}$ , the compressor stop and OD fan stop after 30s.
- The unit can only be restarted after 3 minutes.

### DISCHARGE PIPE TEMPERATURE CONTROL

- Used as a measure of the compressor's internal temperature.
- Compressor frequency is control to keep this temperature from going up further when it rises above a certain level.

#### **Discharge temperature**

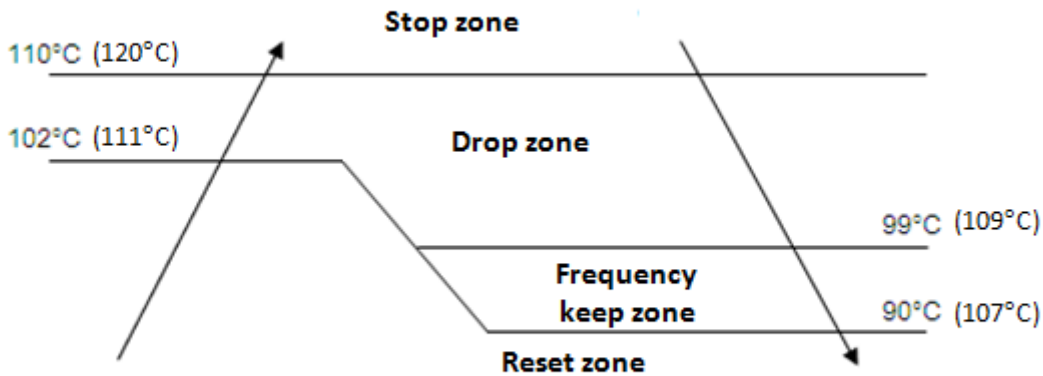

- If compressor discharge temperature  $> 102^{\circ}\text{C}$  ( $111^{\circ}\text{C}$ ) for the first time, this control starts and set the current frequency as upper limit. At the same time, running frequency start to reduce by 1 step and so on, until temperature falls between  $99^{\circ}\text{C}$  ( $109^{\circ}\text{C}$ ) and  $90^{\circ}\text{C}$  ( $107^{\circ}\text{C}$ ) – at the maintain zone.
- This protection is activated when the compressor discharge temperature  $> 110^{\circ}\text{C}$  ( $120^{\circ}\text{C}$ ). The compressor will stop and considered trip.
- If the compressor discharge temperature  $< 90^{\circ}\text{C}$  ( $107^{\circ}\text{C}$ ), the compressor frequency will be reset based on the OD ambient, set and room temperature.

## OVERALL CURRENT CONTROL

- To monitor the overall current and to restrict the compressor upper limit rotation in order to prevent circuit breakers from exceeding the rated capacity.
- Detected during compressor running.

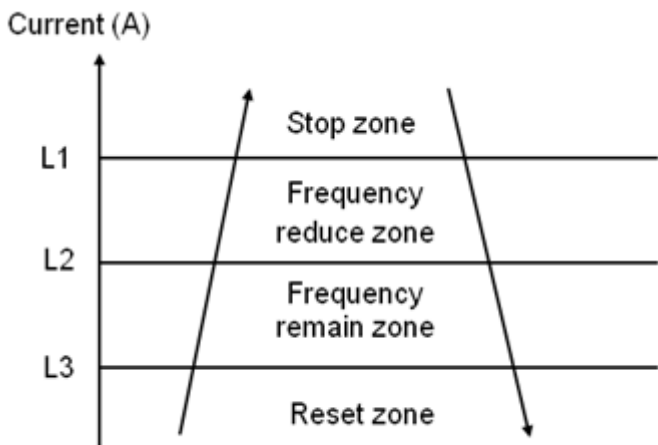

Model	L1
RXN50LV1B	12.0A
RXN60LV1B	12.0A

- When the input current for running compressor exceeds L2, running frequency will be reduced by 1 step. If current still exceeds L2, frequency will be reduced by another 1 step until total current falls between L2 and L3.
- This protection cut in when the input current exceeds L1 for 2 seconds –(RXN-LV ).Compressor will stop and it is considered total current overload.
- If input current <L3, the compressor frequency is reset based on the OD ambient, set and room temperature.

## OIL RECOVERY CONTROL

- When the compressor operates for certain duration at low frequency, the oil level in the compressor may become low due to incomplete oil return.
- To prevent damage to the compressor or compressor lock due to low oil lever.
- To promote refrigerant flow to carry the oil back to the compressor.

---

Entering condition:

- Compressor rotation < 35 Hz, at the end of a 20 minutes timer: set lower limit rotation to 35 Hz & EXV opening is fixed at current opening + 50 pulse. This control is reset when rotation > 35 Hz.

OR

- Compressor rotation > 35 Hz, for every 120 minutes: current rotation is remained & EXV is fixed at current opening + 50 pulse. This control is reset after 5 minutes.

### 3.0 Service Diagnosis

From indoor units

- When any error occurs, indoor LED display will keep blinking – green light:
- The blinking pattern not indicate error details
- The error details have to retrieve from handset in error code form.



LED blinks here

Indoor Wireless Handset: BRC52A61

Using wireless handset BRC52A61 to retrieve error code:



ON TIMER CANCEL



OFF TIMER CANCEL

1. Hold down ON TIMER CANCEL or OFF TIMER CANCEL for 5 seconds until “00” indication flashes on the handset temperature display section.
2. Then, press the same button repeatedly. A series of error code will appear until ID buzzer produces a long beep. The corresponding error code is indicated on the handset temperature display section.



3. ID unit buzzer will produce a long beep if the handset error code matched with unit error.
4. A short and two consecutive beeps is Not the unit error.
5. The code display will cancel itself if the button is not pressed for 1 minute.

### How to Retrieved Last State Error:

- 1) Remove battery from remote controller.
- 2) Replace battery again into remote controller.
- 3) Press Mode & ON/OFF buttons together.
- 4) The “00 “ will show at temperature section.
- 5) Press Mode button to 5:00
- 6) Press Power On. Unit LED blink two times
- 7) ON hold fan button till screen become normal display.



8) Repeat the normal step to retrieve error. (by using remote controller step. Holding TIMER CANCEL...)

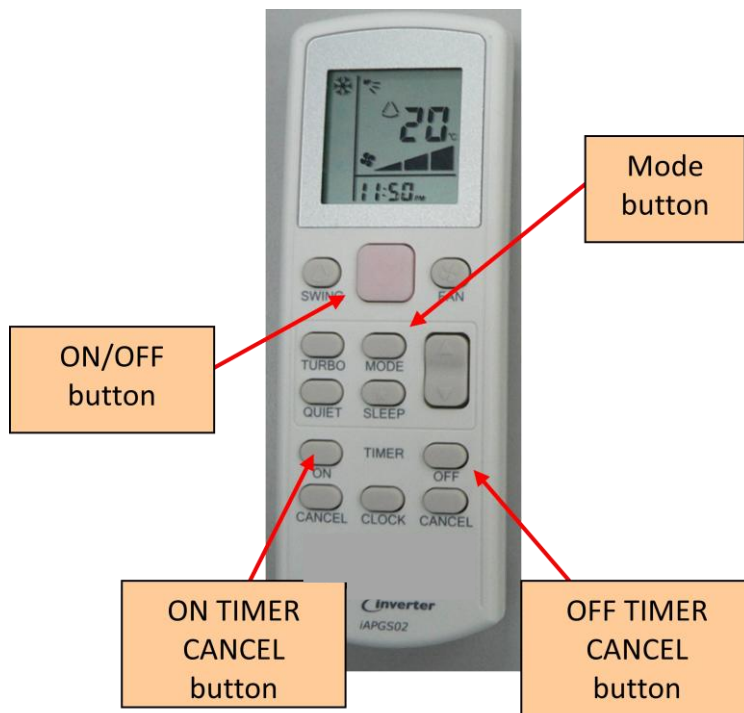

Using wired handset BRC51A61:

- The error will show at the LCD display.
- BRC51A61 can retrieve last state memory by :
- Press SLEEP & TIMER ACTIVE simultaneously for 5 seconds and the error will be flashed.

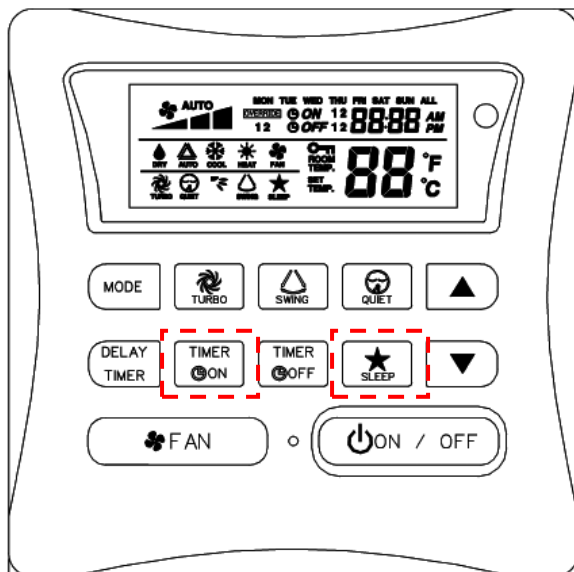

---

**Error code description for Y-series Inverter:**

No .	ERROR CODE	ERROR DESCRIPTION	RXN50,60 LV1B	RXN25,35LV1B
1	00	Normal	√	√
2	A1	INDOOR PCB ERROR	√	√
3	A3	DRAIN PUMP ABNORMAL	√	x
4	A5	ANTIFREEZE PROTECTION	√	√
5	A6	INDOOR FAN MOTOR ABNORMAL	√	√
6	A7	AIR SWING MOTOR LOCK	√	x
7	C4	INDOOR HEAT EXCHANGER THERMISTOR SHORT/OPEN	√	√
8	C9	INDOOR ROOM THERMISTOR SHORT/OPEN	√	√

9	E1	OUTDOOR PCB ERROR	x	√
10	E5	COMPRESSOR OVERLOAD	x	√
11	E6	COMPRESSOR LOCK /START-UP ERROR	√	√
12	E7	OUTDOOR FAN MOTOR LOCK	x	√
13	E8	AC INPUT OVER CURRENT	√	√
14	EA	4 WAY VALVE ERROR	x	√
15	F3	DISCHARGE PIPE OVERHEAT	√	√
16	F6	HEAT EXCHANGER OVERHEAT	√	√
17	H0	COMPRESSOR SENSOR SYSTEM ABNORMAL	x	√
18	H6	POSITION SENSOR ABNORMAL ( compressor )	√	√
19	H8	AC CURRENT SENSOR ERROR	√	√
20	H9	OUTDOOR AIR THERMISTOR SHORT/OPEN	√	√
21	J3	COMPRESSOR DISCHARGE PIPE THERMISTOR SHORT/OPEN/MISPLACED	√	√
22	J6	OUTDOOR HEAT EXCHANGER THERMISTOR SHORT/ OPEN	√	√
23	L3	ELECTRICAL BOX TEMPERATURE RISE ( compressor off )	x	√
24	L4	HEAT SINK OVERHEAT ( compressor on )	√	√
25	L5	IPM ERROR / IGBT ERROR ( output over current )	√	√
26	P4	HEAT SINK THERMISTOR SHORT / OPEN	√	√
27	U0	INSUFFICIENT GAS	√	√

28	U2	DC VOLTAGE OUT OF RANGE	√	√
29	U4	COMMUNICATION ERROR	√	√
30	UA	INSTALLATION ERROR	√	√

**Error Code:**

A1	
Description	Indoor unit PCB abnormality
Supposed Cause	1) Faulty indoor PCB 2) Faulty connector connection at indoor
Troubleshooting	<pre> graph TD     A[Turn off unit] --&gt; B[Check indoor PCB connector conditions (including PCB to terminal block and all PCB wire connector)]     B --&gt; C{Any sign of loose or abnormal}     C -- YES --&gt; D[Connect correctly and operate again]     C -- NO --&gt; E[Replace indoor PCB and operate again] </pre>

A3	
Description	Water Pump Error

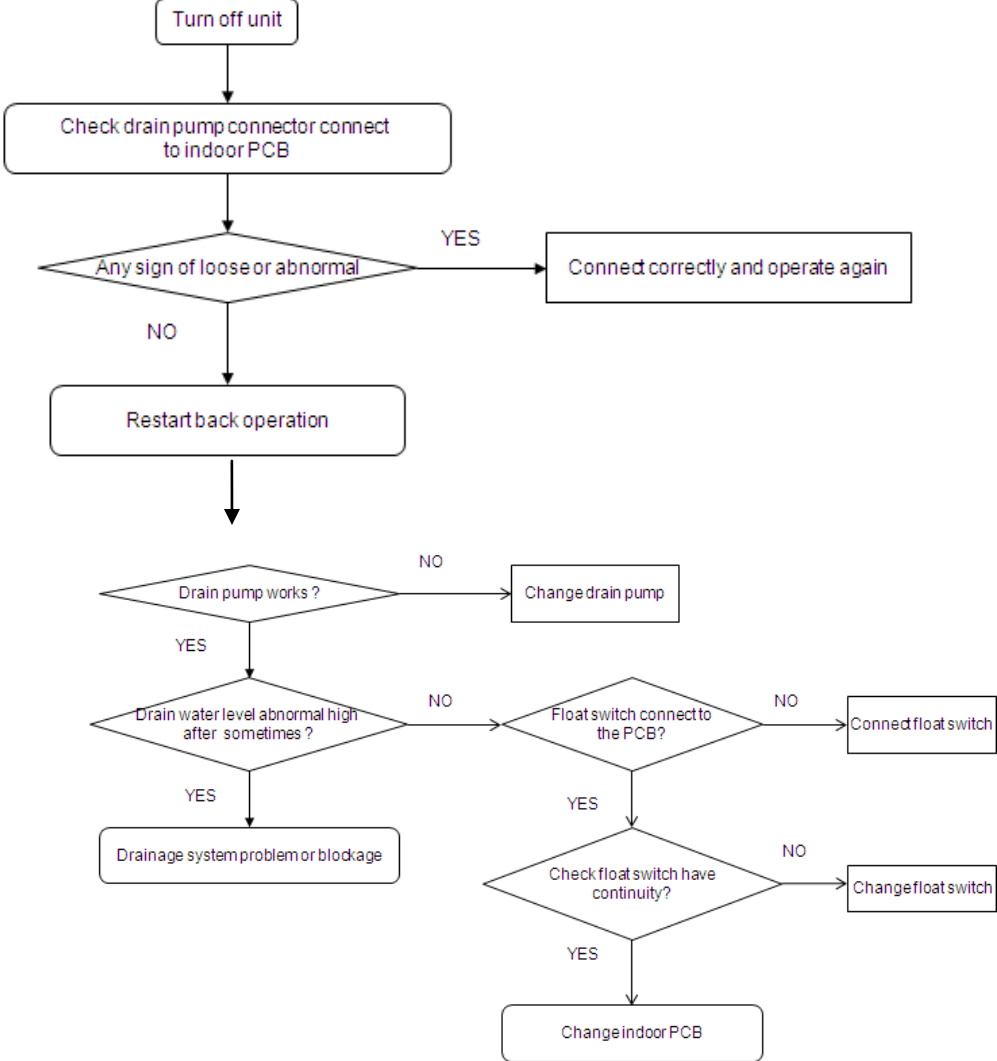
Supposed Cause	1.) Faulty drain pump or float switch 2.) Improper drain piping work or drain pipe blockage
Troubleshooting	 <pre> graph TD     A[Turn off unit] --&gt; B[Check drain pump connector connect to indoor PCB]     B --&gt; C{Any sign of loose or abnormal}     C -- YES --&gt; D[Connect correctly and operate again]     C -- NO --&gt; E[Restart back operation]     E --&gt; F{Drain pump works?}     F -- NO --&gt; G[Change drain pump]     F -- YES --&gt; H{Drain water level abnormal high after sometimes?}     H -- YES --&gt; I[Drainage system problem or blockage]     H -- NO --&gt; J{Float switch connect to the PCB?}     J -- NO --&gt; K[Connected float switch]     J -- YES --&gt; L{Check float switch have continuity?}     L -- NO --&gt; M[Change float switch]     L -- YES --&gt; N[Change indoor PCB]         </pre>

---

A5	
Description	Anti-freeze protection or High Pressure Control
Supposed Cause	1) Indoor air filter, heat exchanger block due to dust accumulation. 2) Indoor air short circuit. 3) Indoor coil thermistor faulty. 4) Indoor PCB faulty. 5) Fan blower dirty
Troubleshooting	

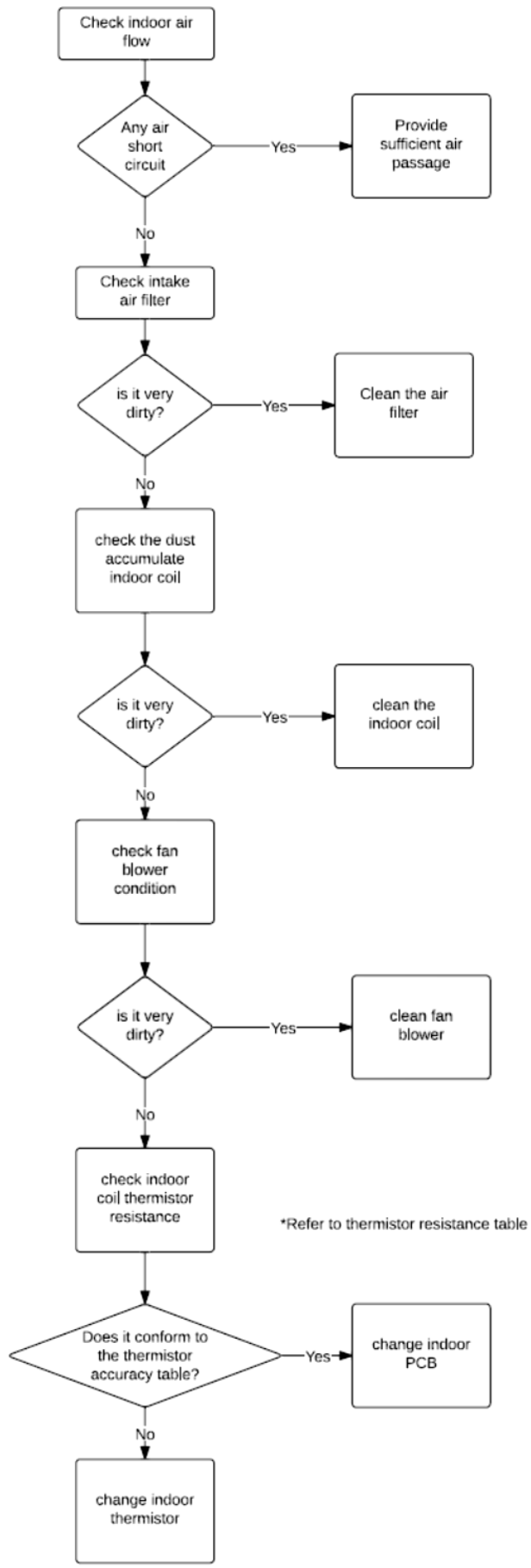





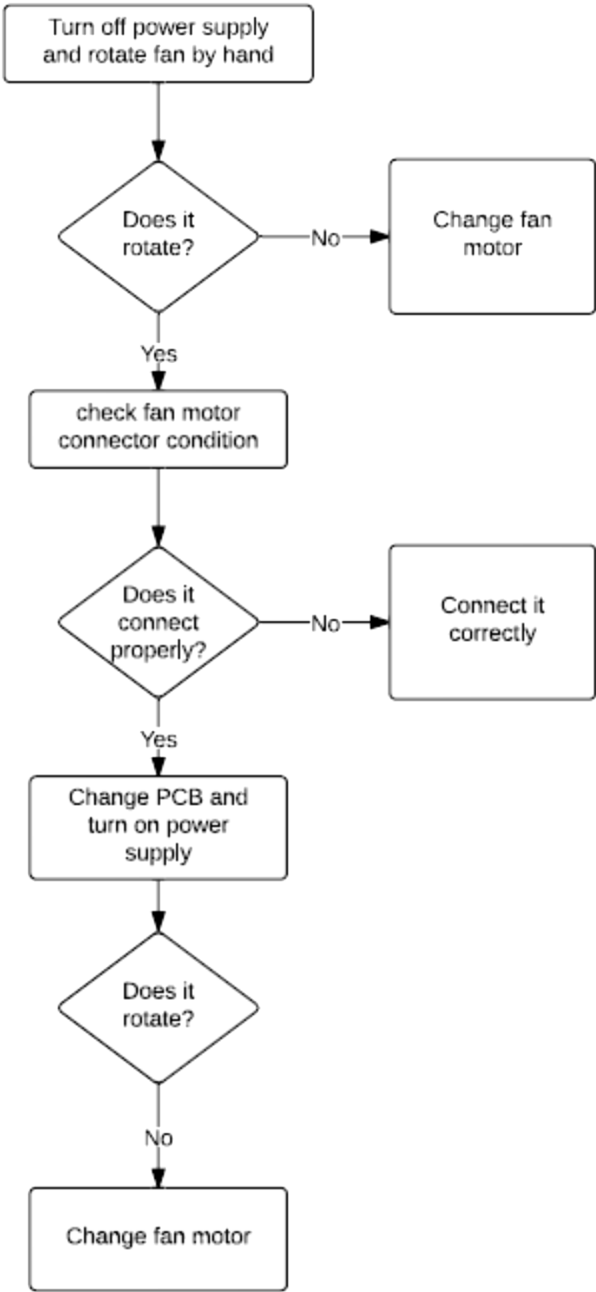

A6

Description	Fan Motor or Related Abnormality
Supposed Cause	1) Indoor fan motor winding short, or the motor lead wire broken 2) Indoor PCB faulty.
Troubleshooting	 <pre>                     graph TD                         Start[Turn off power supply and rotate fan by hand] --&gt; Q1{Does it rotate?}                         Q1 -- No --&gt; A1[Change fan motor]                         Q1 -- Yes --&gt; C1[check fan motor connector condition]                         C1 --&gt; Q2{Does it connect properly?}                         Q2 -- No --&gt; A2[Connect it correctly]                         Q2 -- Yes --&gt; C2[Change PCB and turn on power supply]                         C2 --&gt; Q3{Does it rotate?}                         Q3 -- No --&gt; A3[Change fan motor]                     </pre>

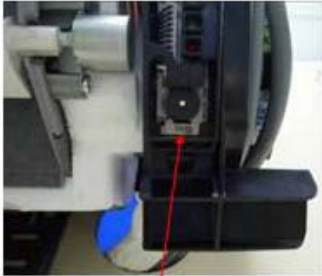
C4	
Description	Indoor Coil Thermistor short/ open
Supposed Cause	1) Thermistor , connector faulty 2) Indoor PCB faulty
Troubleshooting	<pre> graph TD     A[Check the thermistor connector condition] --&gt; B{Normal?}     B -- No --&gt; C[Correct the problem]     B -- Yes --&gt; D[Check thermistor resistance value]     D --&gt; E{Normal?}     E -- No --&gt; F[Replace thermistor]     E -- Yes --&gt; G[Replace PCB]           </pre>

C9	
Description	Indoor Room Thermistor Short /Open
Supposed Cause	1) Thermistor , connector faulty 2) Indoor PCB faulty
Troubleshooting	<pre> graph TD     A[Check the thermistor connector condition] --&gt; B{Normal?}     B -- No --&gt; C[Correct the problem]     B -- Yes --&gt; D[Check thermistor resistance value]     D --&gt; E{Normal?}     E -- No --&gt; F[Replace thermistor]     E -- Yes --&gt; G[Replace PCB]           </pre> <div style="display: flex; justify-content: space-around;"> <div style="text-align: center;">  <p>Air intake gap for room temperature sensing</p> </div> <div style="text-align: center;">  <p>RTH201</p> </div> </div> <p>Unit design with air opening at the front panel to allow sufficient space for air flow and measurement.</p>

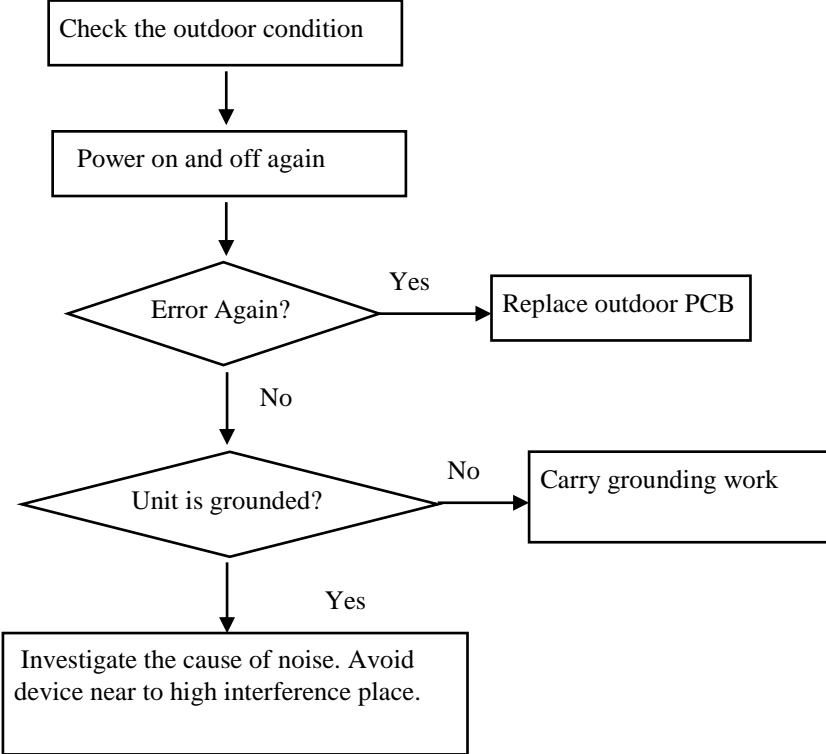

## E1

Description	Outdoor PCB error
Supposed Cause	<ol style="list-style-type: none"><li>1. Micro Controller program run-away due to external factor such as Noise, Momentary voltage drop, Momentary power failure.</li><li>2. Damage of EEPROM</li><li>3. Faulty outdoor unit PCB</li></ol>
Troubleshooting	 <pre>graph TD; A[Check the outdoor condition] --&gt; B[Power on and off again]; B --&gt; C{Error Again?}; C -- Yes --&gt; D[Replace outdoor PCB]; C -- No --&gt; E{Unit is grounded?}; E -- No --&gt; F[Carry grounding work]; E -- Yes --&gt; G[Investigate the cause of noise. Avoid device near to high interference place.];</pre>

E3

Description	High Pressure protection
Supposed Cause	1) faulty high pressure switch , connector or wire harness 2) Indoor filter, outdoor coil dirty. 3) Outdoor fan not running, unit overcharge, stop valve is closed.
Troubleshooting	<pre>           graph TD             A[Check the installation condition] --&gt; B{Stop valve open?}             B -- No --&gt; C[Open the stop valve]             B -- Yes --&gt; D{High pressure switch connect to outdoor PCB?}             D -- No --&gt; E[Conned correctly]             D -- Yes --&gt; F[Turn off unit. Wait for compressor stop 10 minutes]             F --&gt; G{Have continuity for high pressure switch?}             G -- No --&gt; H[Replace high pressure switch]             G -- Yes --&gt; I[Check the abnormal unit high pressure condition]             I --&gt; J{Have abnormal condition?}             J -- Yes --&gt; K[Correct the abnormal condition]             J -- No --&gt; L[Replace outdoor PCB]           </pre> <p># Refer how to check high pressure condition</p>

E4

Description	Low Pressure protection
Supposed Cause	1.) faulty high pressure switch , connector or wire harness 2.) Indoor filter, outdoor coil dirty. 3.) Outdoor fan not running, unit overcharge, stop valve is closed.
Troubleshooting	<pre> graph TD     D1{Stop valve open?} -- No --&gt; A1[Open the stop valve]     D1 -- Yes --&gt; D2{Low pressure switch connect to outdoor PCB?}     D2 -- No --&gt; A2[Connect correctly]     D2 -- Yes --&gt; B1[Measure the voltage between low pressure switch]     B1 --&gt; D3{Relation between Voltage and pressure follow the graph?}     D3 -- No --&gt; A3[Change the low pressure switch]     D3 -- Yes --&gt; D4{Is the refrigerant pressure abnormally low?}     D4 -- No --&gt; A4[Change the Outdoor PCB]     D4 -- Yes --&gt; A5[Correct refrigerant system (gas shortage, leakage or piping block)]       </pre>

E5	
Description	Compressor Overload detected through compressor OL
Supposed Cause	<ul style="list-style-type: none"> <li>- Refrigerant Shortage</li> <li>- 4 way valve malfunction</li> <li>- Outdoor unit PCB defective</li> <li>- Water mixed in the local piping</li> <li>- Electronic expansion valve defective</li> </ul>
Troubleshooting	<pre> graph TD     Start([Turn off unit. Disconnect Compressor wire hardness (U,V,W)]) --&gt; Step1[Check compressor winding resistance]     Step1 --- Note1[# Refer compressor resistance table]     Step1 --&gt; Step2{Resistance normal?}     Step2 -- No --&gt; Step3[Change compressor]     Step2 -- Yes --&gt; Step4[Conned back wire and turn on unit]     Step4 --&gt; Step5{Compressor stop without running?}     Step5 -- Yes --&gt; Step6[Change outdoor PCB]     Step5 -- No --&gt; Step7[Compressor run for sometimes. Check EXV, stop valve, refrigerant level, 4WV and water in the piping, installation condition]   </pre>

E6	
Description	Compressor lock
Supposed Cause	The system will be shut down if the error occurs 16 times. Compressor locked Compressor harness disconnect
Troubleshooting	<pre> graph TD     A[Turn off the power. Disconnect the harness U, V and W] --&gt; B[Check with the inverter checker]     B --&gt; C{Normal?}     C -- No --&gt; D[Correct the power supply]     C -- Yes --&gt; E[Turn off the power and reconnect the harness. Turn on the power again and get the system restarted]     E --&gt; F{Emergency stop without compressor running?}     F -- Yes --&gt; G[Replace the compressor]     F -- No --&gt; H{System shut down after errors repeated several times?}     H -- No --&gt; I[Check the EXV and replaced if required]     H -- Yes --&gt; J[Replace the compressor]           </pre>



## E7

Description	DC Fan Lock
Supposed Cause	-Fan motor breakdown -Harness or connector disconnected between fan motor and PCB or in poor contact
Troubleshooting	<pre>graph TD; Q1{Fan motor connector disconnected?} -- Yes --&gt; A1[Turn off the power and reconnect the connector]; Q1 -- No --&gt; Q2{Foreign matters in or around the fan?}; Q2 -- Yes --&gt; A2[Remove]; Q2 -- No --&gt; B1[Check the outdoor unit PCB rpm pulse input.]; B1 --&gt; Q3{Pulse signal inputted?}; Q3 -- No --&gt; A3[Replace the outdoor unit fan motor]; Q3 -- Yes --&gt; A4[Replace the outdoor unit PCB];</pre> <p>The flowchart outlines the troubleshooting steps for a DC Fan Lock error. It begins with a decision diamond: 'Fan motor connector disconnected?'. If 'Yes', the action is 'Turn off the power and reconnect the connector'. If 'No', it proceeds to another decision diamond: 'Foreign matters in or around the fan?'. If 'Yes', the action is 'Remove'. If 'No', the next step is a process box: 'Check the outdoor unit PCB rpm pulse input.'. This leads to a third decision diamond: 'Pulse signal inputted?'. If 'No', the action is 'Replace the outdoor unit fan motor'. If 'Yes', the final action is 'Replace the outdoor unit PCB'.</p>

E8

Description	Input Over Current Detection
Supposed Cause	<ul style="list-style-type: none"> <li>-over current due to compressor failure</li> <li>-over current due to defective outdoor unit PCB</li> <li>-over current due to defective power transistor</li> <li>-over current due to short-circuit</li> </ul>
Troubleshooting	<pre> graph TD     A[Measure the input current] --&gt; B{Input current flowing above its stop level?}     B -- No --&gt; C[Replace the outdoor unit]     B -- Yes --&gt; D[Check outdoor fan motor, outdoor ambient temperature, refrigerant charge level]     D --&gt; E{Any abnormal?}     E -- Yes --&gt; F[Refer to the type of abnormality and conduct proper service]     E -- No --&gt; G[Turn off the power and disconnect the harness U, V and W]     G --&gt; H[Check with the inverter checker]     H --&gt; I{Compressor faulty?}     I -- Yes --&gt; J[Change Compressor]     I -- No --&gt; K[Change outdoor Control Box]     </pre>

E9	
Description	EXV error
Supposed Cause	<ul style="list-style-type: none"> <li>- EXV faulty</li> <li>- EXV connected wrongly</li> </ul>
Troubleshooting	<pre> graph TD     Q1{Is the EXV connector connects correctly?} -- No --&gt; A[Reconnect]     Q1 -- Yes --&gt; Q2{Turn the power off and back on again. Any latching sound?}     Q2 -- Yes --&gt; B[Outdoor unit PCB is faulty]     Q2 -- No --&gt; C[EXV unit is faulty]           </pre>

EA	
Description	4 way valve error
Supposed Cause	<ul style="list-style-type: none"> <li>- Thermistor defective</li> <li>- Connector in poor contact</li> <li>- 4 way valve defective</li> <li>- Outdoor PCB defective</li> <li>- Insufficient gas</li> <li>- Foreign substance mixed in refrigerant</li> </ul>

Troubleshooting

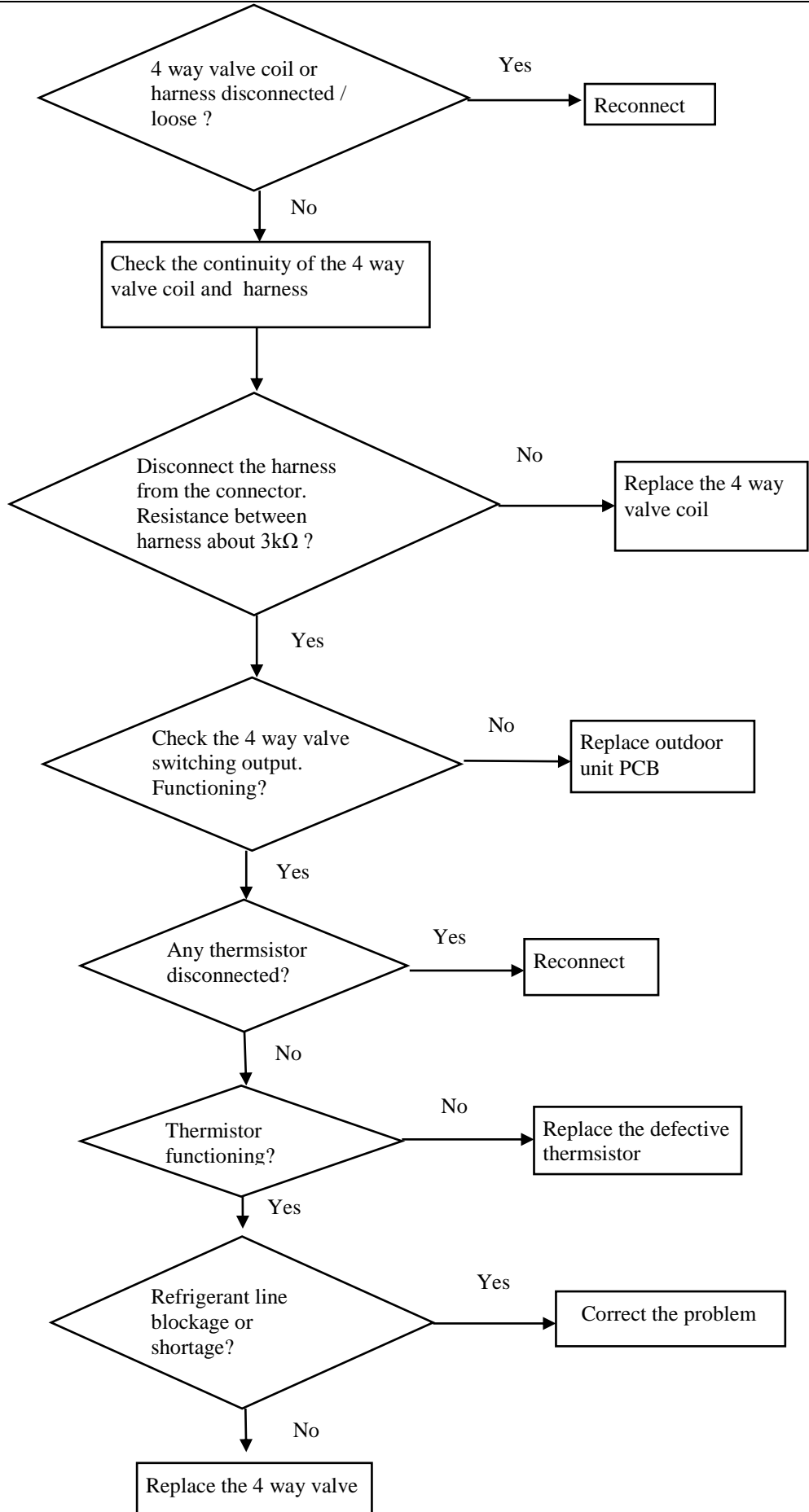

F3	
Description	Discharge pipe overheat
Supposed Cause	<ul style="list-style-type: none"> <li>- Refrigerant shortage</li> <li>- Four way valve malfunctioning</li> <li>- Discharge pipe thermistor defective</li> <li>- Outdoor PCB defective</li> <li>- Water mixed in the local piping</li> <li>- EXV defective</li> <li>- Stop Valve defective</li> </ul>
Troubleshooting	<pre> graph TD     A{Resistance value Normal?} -- Yes --&gt; B[Check refrigerant level, compressor, EXV &amp; stop valve.]     A -- No --&gt; C[Change discharge thermistor]   </pre>

F6	
Description	Heat exchanger overheat
Supposed Cause	<ul style="list-style-type: none"> <li>- The installation space is not large enough</li> <li>- Faulty outdoor unit fan</li> <li>- Faulty EXV</li> <li>- Faulty defrost thermistor</li> <li>- Faulty stop valve</li> <li>- Dirty heat exchanger</li> <li>- Unit overcharge</li> <li>- Working out of operating limit</li> </ul>

Troubleshooting

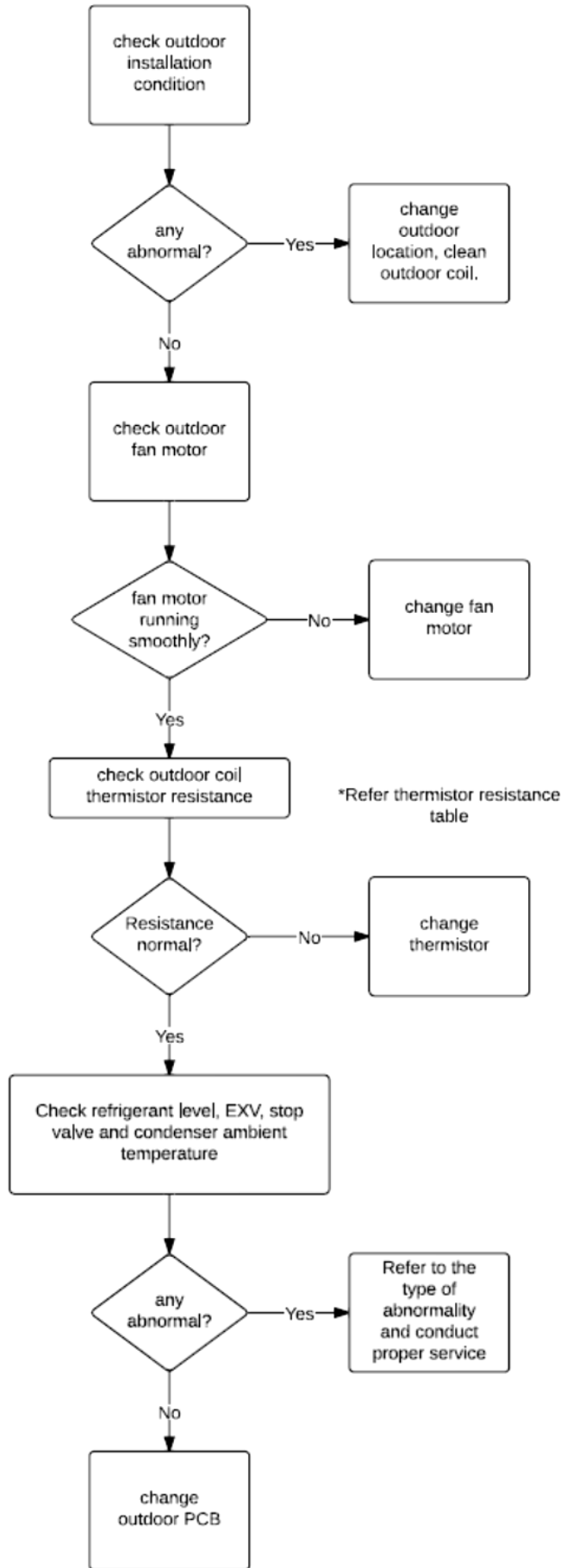

HO	
Description	Compressor sensor system error
Supposed Cause	<ul style="list-style-type: none"> <li>-Reactor disconnection</li> <li>-Compressor disconnection</li> <li>-Outdoor unit PCB defective</li> <li>-Compressor defective</li> </ul>
Troubleshooting	<pre> graph TD     A[Check reactor connection] --&gt; B{Any abnormal?}     B -- Yes --&gt; C[Connected back reactor]     B -- No --&gt; D[Check reactor resistance]     D --&gt; E[Check reactor resistance]     E --- F[# disconnect the reactor wire and measure resistance between terminal]     E --&gt; G{&lt;10 Ω?}     G -- No --&gt; H[Change reactor]     G -- Yes --&gt; I[Check compressor resistance]     I --&gt; J{&lt;10 Ω?}     J -- No --&gt; K[Change compressor]     J -- Yes --&gt; L[Change outdoor PCB] </pre>

H6	
Description	Compressor feedback detection error
Supposed Cause	<ul style="list-style-type: none"> <li>- Compressor relay cable disconnected</li> <li>- Compressor itself defective</li> <li>- Outdoor PCB defective</li> <li>- Stop valve closed</li> <li>- Input voltage out of specification</li> </ul>
Troubleshooting	<pre> graph TD     A[Check for short circuit] --&gt; B{Normal}     B -- No --&gt; C[Replace the outdoor unit PCB, outdoor unit fan]     B -- Yes --&gt; D[Check the electrolytic capacitor voltage]     D --&gt; E{Compressor harness connected as specified?}     E -- No --&gt; F[Reconnect as specified]     E -- Yes --&gt; G[Turn off the power. Disconnect the harness U, V and W]     G --&gt; H[Check with inverter checker]           </pre> <p>The flowchart details the following steps:</p> <ol style="list-style-type: none"> <li>Check for short circuit.</li> <li>Decision: Normal?             <ul style="list-style-type: none"> <li>If No: Replace the outdoor unit PCB, outdoor unit fan.</li> <li>If Yes: Proceed to step 3.</li> </ul> </li> <li>Check the electrolytic capacitor voltage.</li> <li>Decision: Compressor harness connected as specified?             <ul style="list-style-type: none"> <li>If No: Reconnect as specified.</li> <li>If Yes: Proceed to step 5.</li> </ul> </li> <li>Turn off the power. Disconnect the harness U, V and W.</li> <li>Check with inverter checker.</li> </ol>



H8

Description	AC current sensor error
Supposed Cause	<ul style="list-style-type: none"> <li>- Internal wiring broken</li> <li>- Outdoor unit PCB defective</li> </ul>
Troubleshooting	<pre> graph TD     A[Check compressor harness connection] --&gt; B{Connection correct?}     B -- No --&gt; C[Reconnect it correctly]     B -- Yes --&gt; D[Restart the system and check connector between main board and IPM board]     D --&gt; E{Does it connect properly?}     E -- No --&gt; F[Reconnect it properly]     E -- Yes --&gt; G[Change outdoor PCB]             </pre>

H9, J3, J5, J6, J7, J8, J9, P4	
Description	<p>Thermistor or related abnormality</p> <p>H9 : Outdoor air thermistor short/open            J3 : Compressor discharge pipe thermistor short/open            J5 : Suction pipe thermistor short/open            J6 : Outdoor heat exchanger thermistor short/open            J7 : Subcooling heat exchanger thermistor short/open            J8 : Liquid pipe thermistor short/open            J9 : Gas pipe thermistor short/open            P4 : Heat sink thermistor short/open</p>
Supposed Cause	<ul style="list-style-type: none"> <li>- Connector in poor contact</li> <li>- Thermistor defective</li> <li>- Outdoor PCB defective</li> <li>- Indoor PCB defective</li> </ul>
Troubleshooting	<pre> graph TD     A[Check connector for the thermistor with error] --&gt; B{Thermistor disconnected or loose?}     B -- Yes --&gt; C[Connected thermistor back]     B -- No --&gt; D[Check thermistor resistance]     D --&gt; E{Resistance value normal?}     E -- No --&gt; F[Change thermistor]     E -- Yes --&gt; G[Change outdoor PCB]     </pre> <p># Refer thermistor spec and the table.</p>

L3

Description	Outdoor control box overheat
Supposed Cause	<ul style="list-style-type: none"> <li>- Fin temperature rise due to defective outdoor unit fan</li> <li>- Fin temperature rise due to short circuit</li> <li>- Fin thermistor defective</li> <li>- Connector in poor contact</li> <li>- Outdoor unit PCB defective</li> </ul>
Troubleshooting	<pre> graph TD     Start([Turn off the unit and turn on back after 20 mins]) --&gt; Error{Error again?}     Error -- No --&gt; Fan[Check outdoor fan]     Error -- Yes --&gt; Resistor[Check heat sink thermistor resistance]     Fan --&gt; FanFunc{Outdoor fan functioning?}     FanFunc -- No --&gt; FanMotor[Change outdoor fan motor]     FanFunc -- Yes --&gt; Dirty{Heat sink dirty?}     Dirty -- No --&gt; Install[Check installation condition]     Dirty -- Yes --&gt; Clean[Clean the heat sink]     Resistor --&gt; ResNormal{Resistance normal?}     ResNormal -- No --&gt; ChangeThermistor[Change thermistor]     ResNormal -- Yes --&gt; Temp{Heat sink temperature &gt; 80°C?}     Temp -- No --&gt; ChangePCB[Change outdoor PCB]     Temp -- Yes --&gt; ChangeSink[Change heat sink or check outdoor fan condition]     </pre> <p># Refer thermistor spec and the table.</p>

L4

Description	Heat sink overheat
Supposed Cause	<ul style="list-style-type: none"> <li>- Fin temperature rise due to short circuit</li> <li>- Fin temperature rise due to defective outdoor unit fan</li> <li>- Fin thermistor defective</li> <li>- Connector in poor contact</li> <li>- Outdoor unit PCB defective</li> <li>- Silicon grease is not applied properly on the hat radiation fin after replacing outdoor unit PCB.</li> </ul>
Troubleshooting	<pre> graph TD     Start[Turn off the unit and turn on back after 20 minutes] --&gt; Error{Error again?}     Error -- Yes --&gt; CheckRes[Check heat sink thermistor resistance]     Error -- No --&gt; CheckFan[Check outdoor fan]     CheckRes --&gt; ResNormal{Resistance normal?}     ResNormal -- No --&gt; ChangeTherm[Change thermistor]     ResNormal -- Yes --&gt; TempCheck{Heat sink temperature &gt;83°C?}     TempCheck -- No --&gt; ChangePCB[Change outdoor PCB]     TempCheck -- Yes --&gt; CheckFan     CheckFan --&gt; FanFunc{Outdoor fan functioning?}     FanFunc -- No --&gt; ChangeMotor[Change outdoor fan motor]     FanFunc -- Yes --&gt; Dirty{Heat sink dirty?}     Dirty -- No --&gt; CheckInst[Check installation condition]     Dirty -- Yes --&gt; CleanSink[Clean the heat sink]     </pre>

<i>L5</i>	
Description	IPM error/IGBT error
Supposed Cause	<ul style="list-style-type: none"> <li>- Over current due to defective power transistor</li> <li>- Over current due to wrong internal wiring</li> <li>- Over current due to abnormal supply voltage</li> <li>- Over current due to defective PCB</li> <li>- Error detection due to defective PCB</li> <li>- Over- current due to closed stop valve</li> <li>- Over current due to compressor failure</li> <li>- Over current due to poor installation condition</li> <li>- Connection between main board and IPM board is not properly connect</li> </ul>
Troubleshooting	<pre> graph TD     A{Stop valve fully open?} -- No --&gt; B[Open stop valve]     A -- Yes --&gt; C[Turn off the unit and turn on back after 20 mins]     C --&gt; D{Error again?}     D -- No --&gt; E[Continue monitor for supply voltage, discharge, suction pressure, compressor overload, Check for silicon grease at IPM condition]     D -- Yes --&gt; F[Turn off the unit and disconnect compressor U,V,W wire]     F --&gt; G[Check compressor winding resistance]     G --&gt; H{Resistance normal?}     H -- No --&gt; I[Change compressor]     H -- Yes --&gt; J[Change the Outdoor PCB]     </pre>

<i>U0</i>	
Description	Insufficient gas
Supposed Cause	<ul style="list-style-type: none"> <li>- Refrigerant shortage</li> <li>- Refrigerant leakage</li> <li>- Stop valve closed</li> <li>- EXV defective</li> <li>- Discharge pipe thermistor defect</li> <li>- Indoor and outdoor unit coil thermistor not in actual location or defect</li> </ul>

Troubleshooting

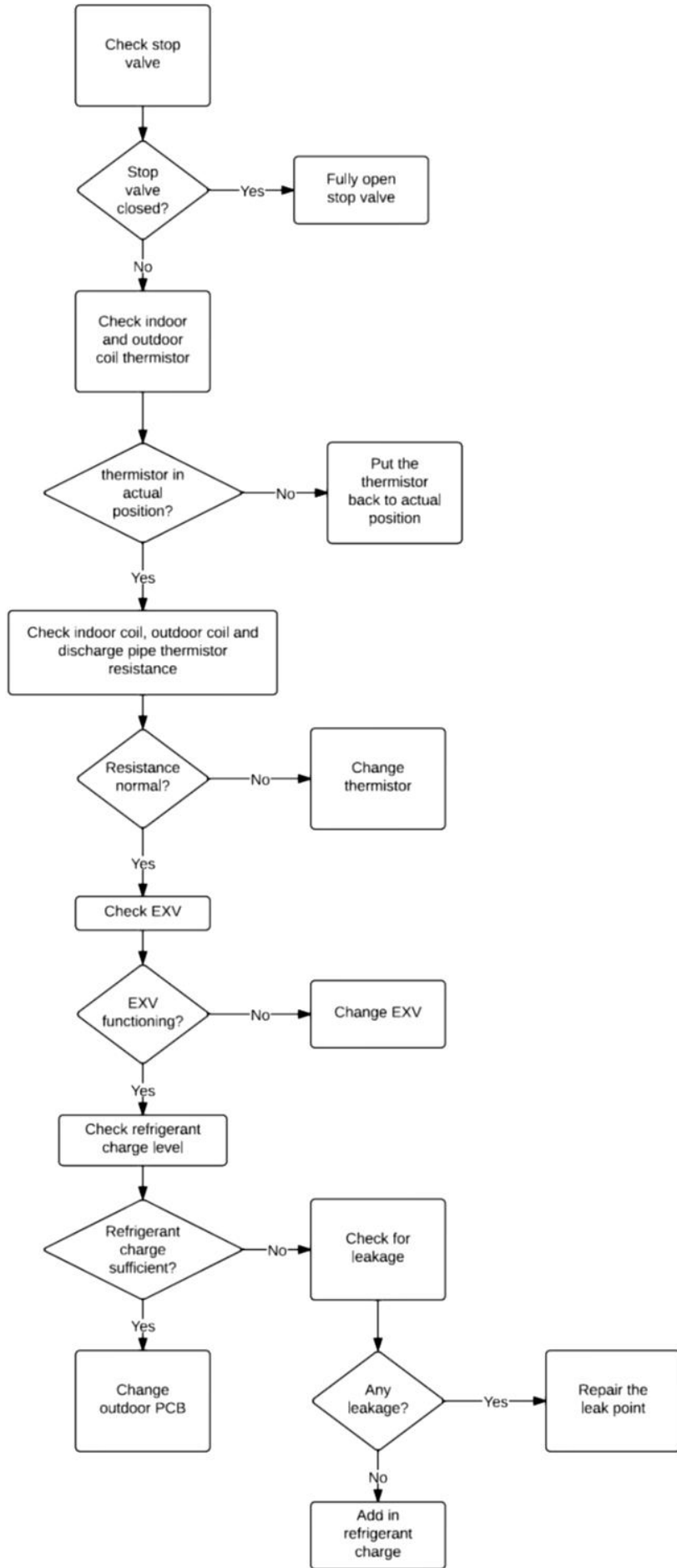

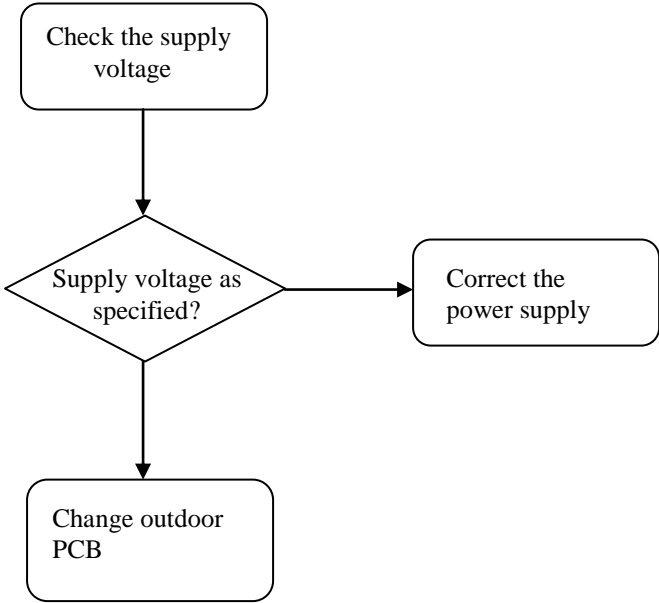
U2	
Description	DC voltage out of range
Supposed Cause	<ul style="list-style-type: none"> <li>- Supply voltage not as specified</li> <li>- DC voltage detection circuit defective</li> </ul>
Troubleshooting	<div style="text-align: center;">  <pre> graph TD     A[Check the supply voltage] --&gt; B{Supply voltage as specified?}     B --&gt; C[Correct the power supply]     B --&gt; D[Change outdoor PCB]           </pre> </div>

U4	
Description	Communication error (between indoor and outdoor)
Supposed Cause	<ul style="list-style-type: none"> <li>- Faulty outdoor unit PCB</li> <li>- Faulty indoor unit PCB</li> <li>- Indoor unit – outdoor unit signal transmission error due to wiring error.</li> <li>- Indoor unit – outdoor unit signal transmission error due to disturbed power supply waveform.</li> <li>- Indoor unit- Outdoor unit signal transmission error due to breaking of wire in the connection wires between the indoor and outdoor units.</li> </ul>
Troubleshooting	

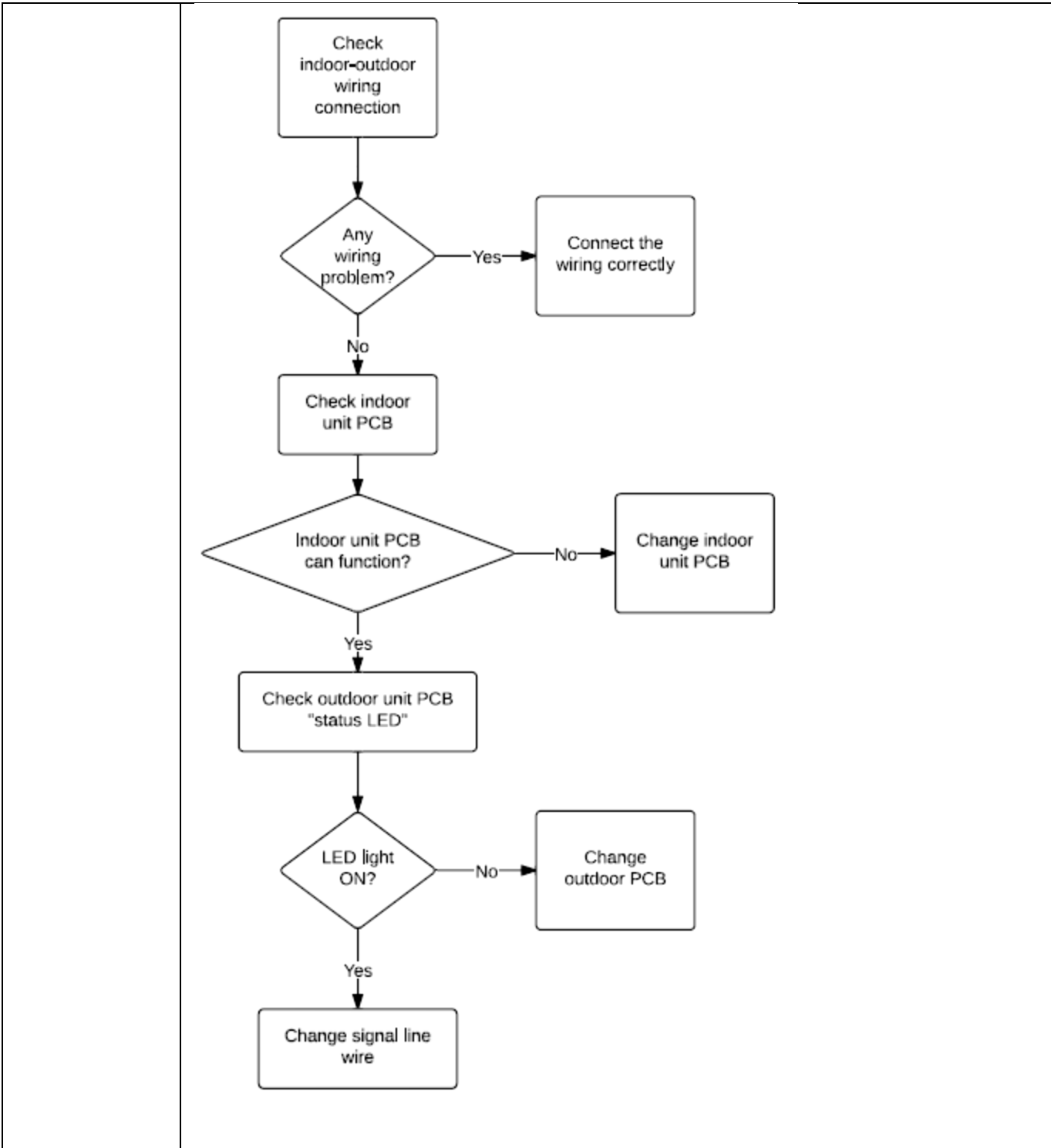



UA

Description	Communication error (outdoor PCB & IPM PCB)
Supposed Cause	<ul style="list-style-type: none"><li>- Wrong models interconnected</li><li>- Wrong indoor unit PCB mounted</li><li>- Indoor unit PCB defective</li><li>- Wrong outdoor unit PCB mounted or defective</li></ul>
Troubleshooting	<div style="text-align: center;"><div style="border: 1px solid black; padding: 5px; width: fit-content; margin: 0 auto;">Check the models number</div><div style="text-align: center; margin: 5px 0;">↓</div><div style="border: 1px solid black; padding: 5px; width: fit-content; margin: 0 auto;">Check the combination of the models</div></div>

## 4.0 Wiring Connection

FTXN 25/35 LV1B  
RXN 25/35 LV1B

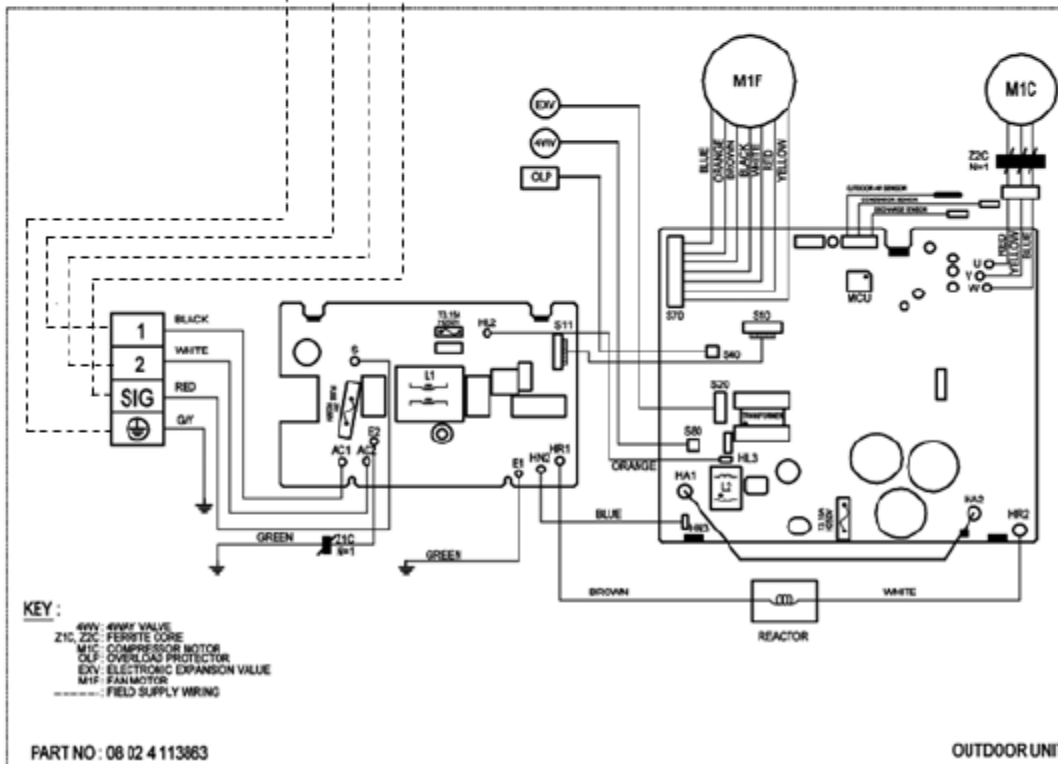
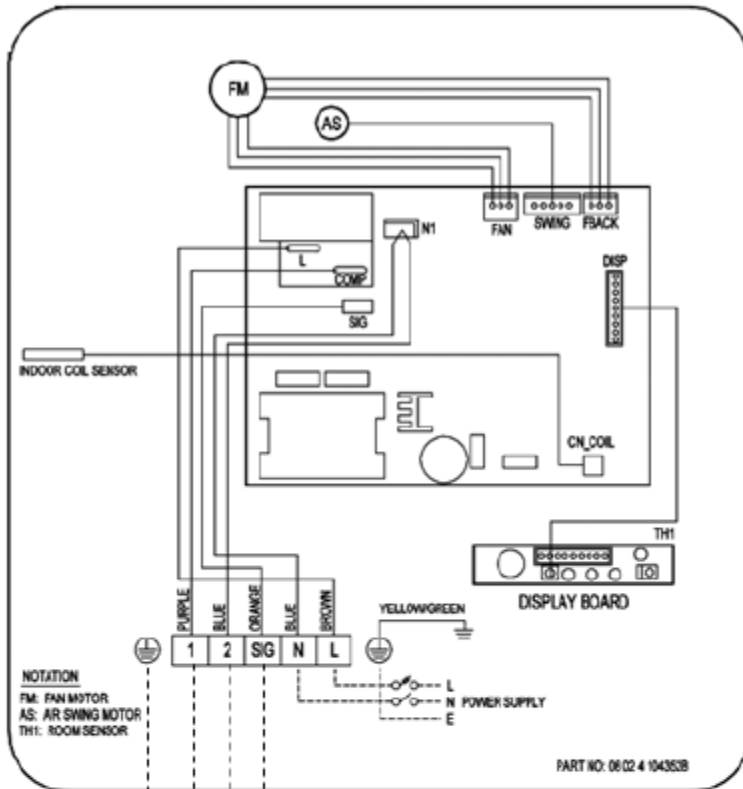

FTXN 50/60 LV1B  
RXN50/60 LV1B

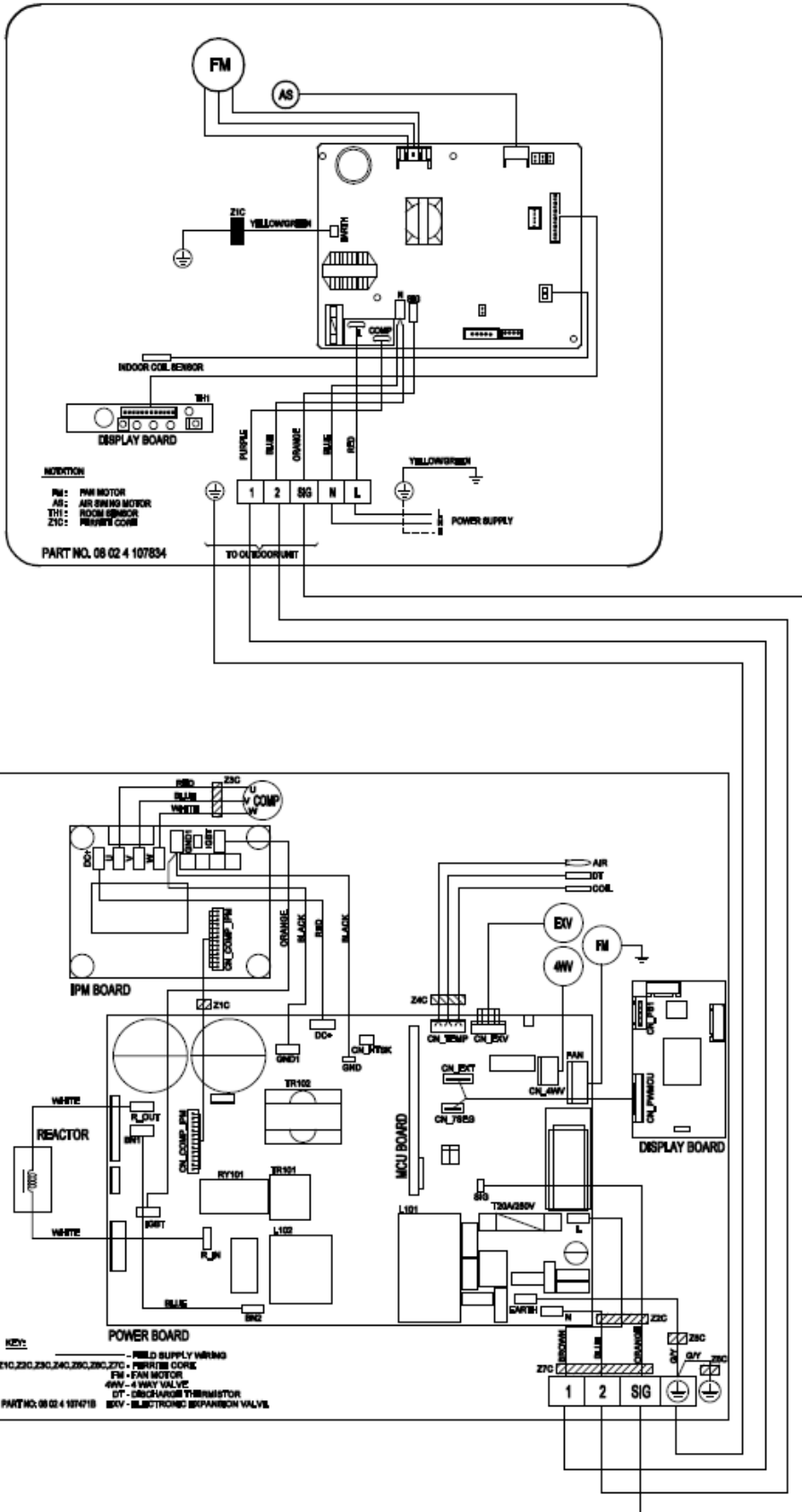

**Refrigerant Diagram:**

FTXN 25/35 LV1B

RXN 25/35 LV1B

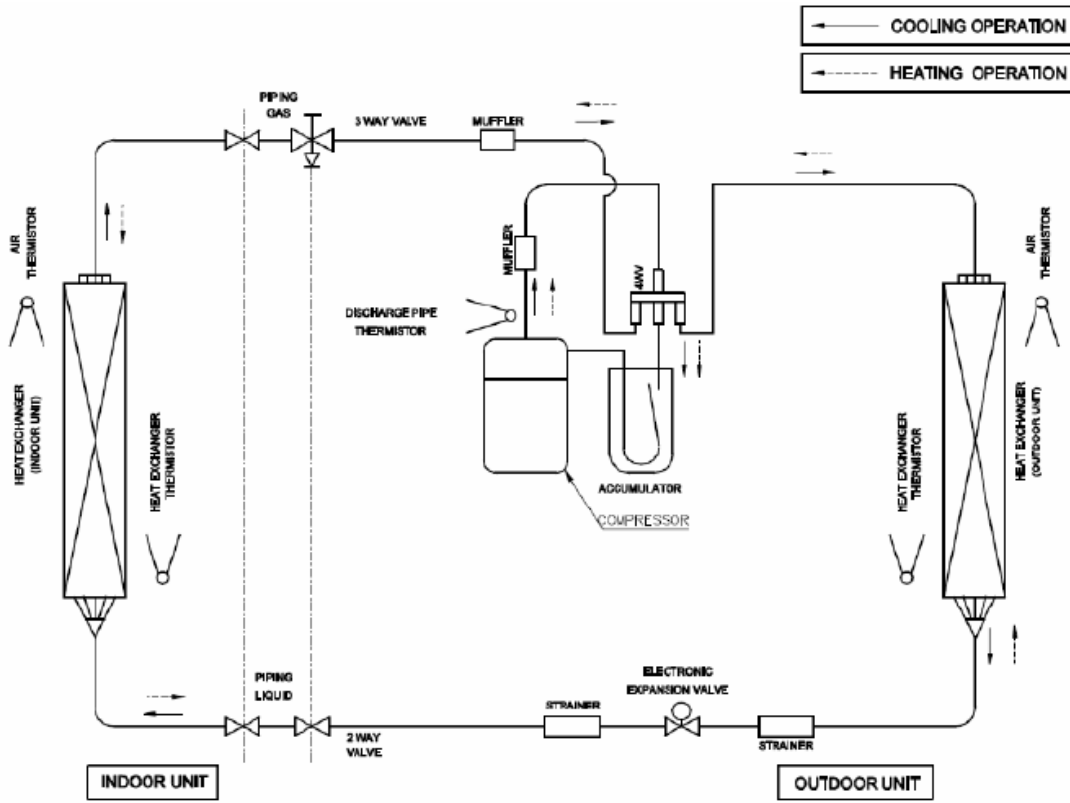

FTXN 50/60 LV1B

RXN50/60 LV1B

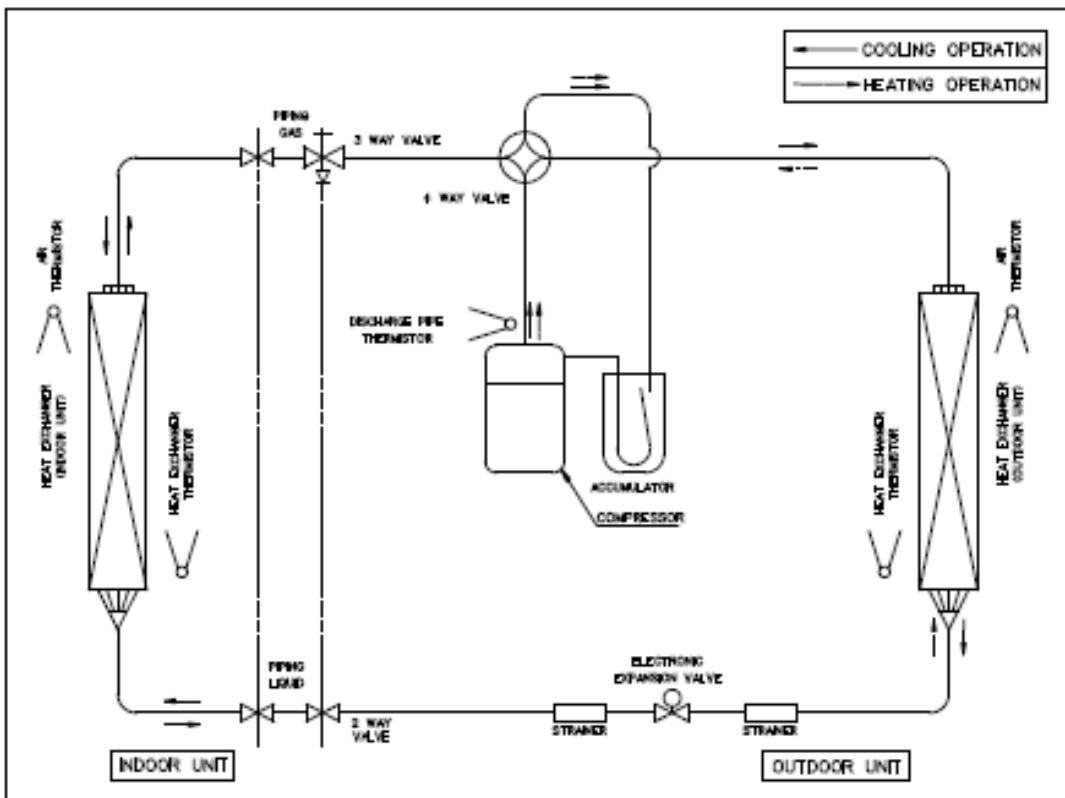

**Appendix:**

Resistance value when 25°C :

		RXN50/60 LV1B	RXN 25/35 LV1B
Indoor	WM	10K	10K
	CC,CK, CM	10K	-----
Outdoor		10K	20K

Table 1: Resistance R25 = 10K ohm

t°C	Rmin (kΩ)	Rnom (kΩ)	Rmax (kΩ)	t°C	Rmin (kΩ)	Rnom (kΩ)	Rmax (kΩ)
-10	4.42E+01	4.53E+01	4.65E+01	41	5.47E+00	5.56E+00	5.64E+00
-9	4.21E+01	4.32E+01	4.43E+01	42	5.28E+00	5.37E+00	5.45E+00
-8	4.02E+01	4.12E+01	4.22E+01	43	5.10E+00	5.18E+00	5.27E+00
-7	3.83E+01	3.92E+01	4.02E+01	44	4.92E+00	5.01E+00	5.09E+00
-6	3.66E+01	3.74E+01	3.83E+01	45	4.75E+00	4.84E+00	4.92E+00
-5	3.49E+01	3.57E+01	3.65E+01	46	4.59E+00	4.67E+00	4.76E+00
-4	3.33E+01	3.41E+01	3.49E+01	47	4.44E+00	4.52E+00	4.60E+00
-3	3.18E+01	3.26E+01	3.33E+01	48	4.29E+00	4.37E+00	4.42E+00
-2	3.04E+01	3.11E+01	3.18E+01	49	4.15E+00	4.22E+00	4.30E+00
-1	2.90E+01	2.97E+01	3.03E+01	50	4.01E+00	4.09E+00	4.16E+00
0	2.78E+01	2.84E+01	2.90E+01	51	3.88E+00	3.95E+00	4.03E+00
1	2.66E+01	2.71E+01	2.77E+01	52	3.75E+00	3.82E+00	3.90E+00
2	2.54E+01	2.59E+01	2.65E+01	53	3.63E+00	3.70E+00	3.77E+00
3	2.43E+01	2.48E+01	2.53E+01	54	3.51E+00	3.58E+00	3.65E+00
4	2.33E+01	2.37E+01	2.42E+01	55	3.40E+00	3.47E+00	3.54E+00
5	2.23E+01	2.27E+01	2.31E+01	56	3.29E+00	3.36E+00	3.43E+00
6	2.14E+01	2.18E+01	2.21E+01	57	3.18E+00	3.25E+00	3.32E+00
7	2.05E+01	2.08E+01	2.12E+01	58	3.08E+00	3.15E+00	3.22E+00
8	1.96E+01	2.00E+01	2.03E+01	59	2.98E+00	3.05E+00	3.12E+00
9	1.88E+01	1.91E+01	1.94E+01	60	2.89E+00	2.96E+00	3.01E+00
10	1.80E+01	1.83E+01	1.86E+01	61	2.80E+00	2.86E+00	2.93E+00
11	1.73E+01	1.76E+01	1.78E+01	62	2.71E+00	2.78E+00	2.84E+00
12	1.66E+01	1.69E+01	1.71E+01	63	2.63E+00	2.69E+00	2.75E+00
13	1.59E+01	1.62E+01	1.64E+01	64	2.55E+00	2.61E+00	2.67E+00
14	1.53E+01	1.55E+01	1.57E+01	65	2.47E+00	2.53E+00	2.59E+00
15	1.47E+01	1.49E+01	1.51E+01	66	2.40E+00	2.45E+00	2.51E+00
16	1.41E+01	1.43E+01	1.45E+01	67	2.32E+00	2.38E+00	2.44E+00
17	1.35E+01	1.37E+01	1.39E+01	68	2.25E+00	2.31E+00	2.37E+00
18	1.30E+01	1.32E+01	1.33E+01	69	2.19E+00	2.24E+00	2.30E+00
19	1.25E+01	1.27E+01	1.28E+01	70	2.12E+00	2.17E+00	2.23E+00
20	1.20E+01	1.22E+01	1.23E+01	71	2.06E+00	2.11E+00	2.17E+00
21	1.16E+01	1.17E+01	1.18E+01	72	2.00E+00	2.05E+00	2.10E+00
22	1.11E+01	1.12E+01	1.14E+01	73	1.94E+00	1.99E+00	2.04E+00
23	1.07E+01	1.08E+01	1.09E+01	74	1.88E+00	1.93E+00	1.98E+00
24	1.03E+01	1.04E+01	1.05E+01	75	1.83E+00	1.88E+00	1.93E+00
25	9.90E+00	1.00E+01	1.01E+01	76	1.77E+00	1.82E+00	1.87E+00
26	9.52E+00	9.62E+00	9.72E+00	77	1.72E+00	1.77E+00	1.82E+00
27	9.16E+00	9.26E+00	9.36E+00	78	1.67E+00	1.72E+00	1.77E+00
28	8.82E+00	8.92E+00	9.02E+00	79	1.63E+00	1.67E+00	1.72E+00
29	8.49E+00	8.59E+00	8.69E+00	80	1.58E+00	1.62E+00	1.67E+00
30	8.17E+00	8.27E+00	8.37E+00	81	1.53E+00	1.58E+00	1.62E+00
31	7.87E+00	7.97E+00	8.07E+00	82	1.49E+00	1.53E+00	1.58E+00
32	7.58E+00	7.68E+00	7.78E+00	83	1.45E+00	1.49E+00	1.54E+00
33	7.31E+00	7.40E+00	7.50E+00	84	1.41E+00	1.45E+00	1.49E+00
34	7.04E+00	7.14E+00	7.23E+00	85	1.37E+00	1.41E+00	1.45E+00
35	6.79E+00	6.88E+00	6.98E+00	86	1.33E+00	1.37E+00	1.41E+00
36	6.54E+00	6.64E+00	6.73E+00	87	1.30E+00	1.33E+00	1.38E+00
37	6.31E+00	6.40E+00	6.50E+00	88	1.26E+00	1.30E+00	1.34E+00
38	6.09E+00	6.18E+00	6.27E+00	89	1.23E+00	1.26E+00	1.30E+00
39	5.87E+00	5.96E+00	6.05E+00	90	1.19E+00	1.23E+00	1.27E+00
40	5.67E+00	5.75E+00	5.84E+00				

---

Table 2: Resistance R25 = 20K ohm

Temperature (°C)	Resistance value (kΩ)
-20	211.0
-15	150.0
-10	116.5
-5	88.0
0	67.2
5	51.9
10	40.0
15	31.8
20	25.0
25	20.0
30	16.0
35	13.0
40	10.6
45	8.7
50	7.2