



CLARITY ROCKER BOX COVERS



PRODUCT DESCRIPTION

2000-UP TWIN CAM MODELS: CLARITY ROCKER BOX COVERS

0177-2034

For questions pertaining to the installation of this product, please contact the Performance Machine technical department at 1-800-479-4037. This product is manufactured in the USA by Performance Machine LLC.

RSD CLARITY ROCKER BOX COVERS INSTALLATION

1. Turn your motorcycle off, place securely on a lift or side stand and disconnect the battery.
2. Remove the fuel tank. **Note:** refer to the HD service manual for additional instructions.
3. With the tank removed, remove the factory rocker box covers. Clean and inspect all sealing surfaces. **Note:** refer to the HD service manual for specific instructions.
WARNING: Do not use any harsh chemicals during cleaning!
4. Install the front rocker box cover gasket (9) and RSD rocker box (7) from the right side of the bike (exhaust side). **Disclaimer:** install slowly to avoid damage to the cover or the motorcycle.

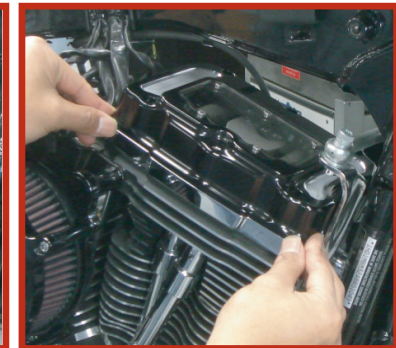

5. Once the RSD rocker box cover is in the correct position, insert the 6 supplied 5/16" bolts (1, 2, 3, 4) and washers (6) and torque to 15-18 ft-lbs using blue threadlocker. **Note:** Review page 2 diagram for proper bolt positions.



CAUTION:

CLARITY WINDOW IS PERMANENTLY INSTALLED AT THE FACTORY AND SHOULD NOT BE REMOVED OR SERVICED. IF REMOVAL IS NECESSARY CONTACT THE TECH DEPARTMENT FOR SPECIAL SERVICE INSTRUCTIONS. PERFORMANCE MACHINE THE MANUFACTURER IS NOT RESPONSIBLE FOR DAMAGE TO THE CLARITY WINDOW CAUSED BY IMPROPER SERVICE.



Clarity Rocker Box Covers

RSD CLARITY ROCKER BOX COVERS INSTALLATION (continued)

6. Install the rear rocker box cover gasket (9) and RSD rocker box (7) from the right side of the bike (exhaust side). **Disclaimer:** install slowly to avoid damage to the cover or the motorcycle.

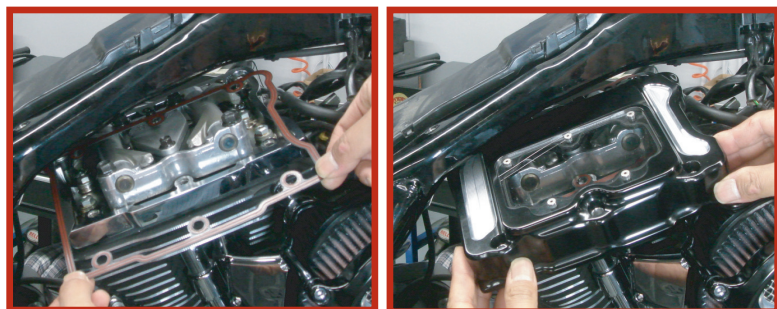

7. Once the RSD rocker box cover is in the correct position, insert the 6 supplied 5/16" bolts (1, 2, 3, 4) and washers (6) and torque to 15-18 ft-lbs using blue threadlocker. **Note:** Review the diagram to the right for proper bolt positions. **Tip:** On some models there is limited clearance on the rear cylinder so using a small hex driver and wrench will allow easier installation FIG A.

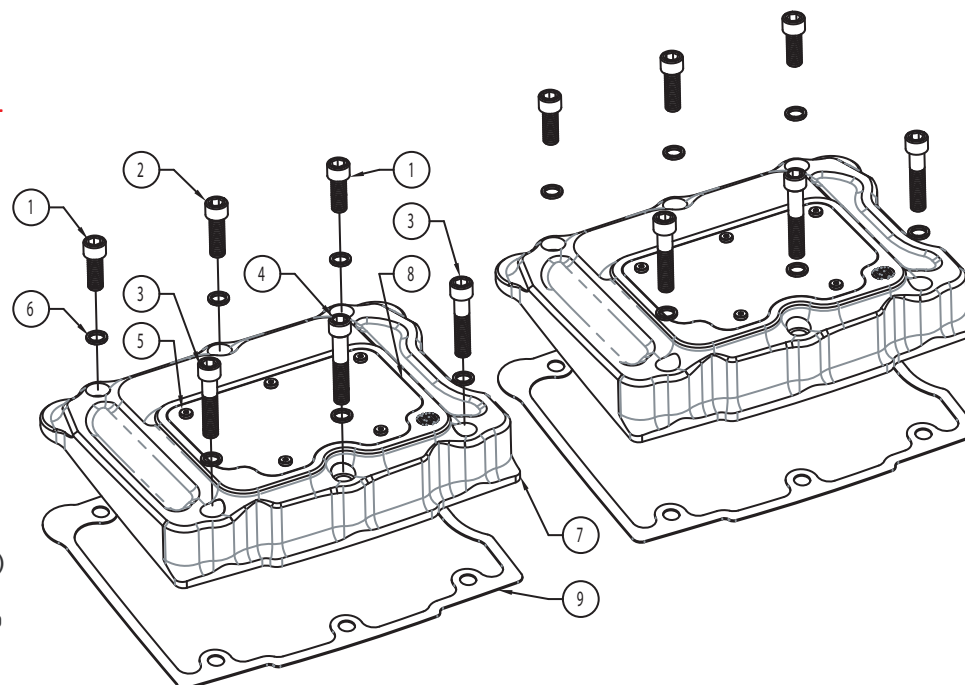
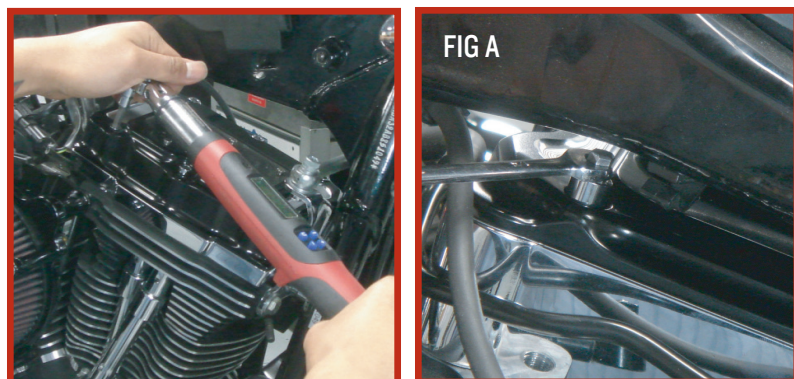

CAUTION:

CLARITY WINDOW IS PERMANENTLY INSTALLED AT THE FACTORY AND SHOULD NOT BE REMOVED OR SERVICED. IF REMOVAL IS NECESSARY CONTACT THE TECH DEPARTMENT FOR SPECIAL SERVICE INSTRUCTIONS. PERFORMANCE MACHINE THE MANUFACTURER IS NOT RESPONSIBLE FOR DAMAGE TO THE CLARITY WINDOW CAUSED BY IMPROPER SERVICE.

USE ONLY POLYCARBONATE APPROVED CLEANERS SUCH AS PLEXUS TO CLEAN YOUR CLARITY WINDOW. HARSH CHEMICALS MAY CAUSE DAMAGE.

NOTE: FOGGING MAY OCCUR ON THE INSIDE OF THE LEXAN WINDOWS DUE TO HUMIDITY CHANGES. IF FOGGING IS VISIBLE START THE MOTORCYCLE AND RUN UNTIL FOGGING DISAPPEARS.

ITEM NO.	DESCRIPTION	QTY.
1	SHCS 5/16-18 X 7/8	4
2	SHCS 5/16-18 X 1 - CHROME	2
3	SHCS 5/16-18 X 1-1/2 CHROME	4
4	SHCS 5/16-18 X 1-3/4, CHROME	2
5	SHCS LOW HEAD 8-32 X 1/2 W/VIBRA-TITE	10
6	WASHER .316 X .440 X .060, STAINLESS	12
7	RSD CLARITY, TWIN CAM ROCKER COVER BOX, 1999-UP	2
8	WINDOW, RSD CLARITY TWIN CAM ROCKER BOX COVER	2
9	GASKET, TWIN CAM ROCKER BOX COVER 1999-UP	2

8. Install the fuel tank and any other components that have been removed.

9. Hit the road!