



US008382019B2

(12) **United States Patent**
Romanovich et al.

(10) **Patent No.:** **US 8,382,019 B2**
(45) **Date of Patent:** **Feb. 26, 2013**

(54) **IN-RUSH CURRENT JAM PROOF SENSOR CONTROL**

4,378,717 A 4/1983 Schneider et al.
4,489,897 A 12/1984 Turner
4,495,456 A 1/1985 Vercillo et al.
4,497,478 A 2/1985 Reschenhofer
4,683,381 A 7/1987 Dufoug
(Continued)

(75) Inventors: **Dmitry Romanovich**, Wheaton, IL (US); **Michael Dale Jensen**, Wood Dale, IL (US)

FOREIGN PATENT DOCUMENTS

(73) Assignee: **Fellowes, Inc.**, Itasca, IL (US)

DE 3313232 10/1984
DE 8619856.4 10/1988

(*) Notice: Subject to any disclaimer, the term of this patent is extended or adjusted under 35 U.S.C. 154(b) by 316 days.

(Continued)

OTHER PUBLICATIONS

(21) Appl. No.: **12/772,722**

Complaint for Declaratory Judgment filed on Nov. 15, 2010 by *Royal Appliance Manufacturing Co., d/b/a/ TTI Floor Care North America and Techtronic Industries Co. Ltd.* against *Fellowes, Inc.*

(22) Filed: **May 3, 2010**

(Continued)

(65) **Prior Publication Data**

US 2011/0266379 A1 Nov. 3, 2011

Primary Examiner — Bena Miller

(51) **Int. Cl.**

B02C 4/32 (2006.01)
B02C 7/14 (2006.01)
B02C 9/04 (2006.01)

(74) *Attorney, Agent, or Firm* — Pillsbury Winthrop Shaw Pittman LLP

(52) **U.S. Cl.** **241/36; 241/100; 241/236**

(58) **Field of Classification Search** **241/33, 241/35, 36, 100, 236, 27, 30**

(57) **ABSTRACT**

See application file for complete search history.

A shredder and a method for monitoring a motor of a shredder comprises a housing having a throat for receiving an article and a shredder mechanism received in the housing for shredding the article, the mechanism including an electrically powered motor and cutter elements, and the motor being operable to drive the cutter elements in a shredding direction to shred articles. A current sensor for detecting current flowing through the motor and a controller coupled to the motor for controlling operation of the motor are also provided. The controller is also coupled to the current sensor and configured to detect at least an initial amount of current (or inrush current) supplied to the motor for each shredding event. Based on the inrush current, the controller sets a parameter (e.g., overload or thickness) to prevent overloading or stalling of the motor, such as caused by a jam or overheating.

(56) **References Cited**

U.S. PATENT DOCUMENTS

2,221,516 A 4/1937 Hathaway
3,619,537 A 11/1971 Hosokawa et al.
3,724,766 A 4/1973 Bosland
3,764,819 A 10/1973 Muller
3,785,230 A 1/1974 Lokey
3,829,850 A 8/1974 Guetersloh
3,947,734 A 3/1976 Fyler
4,192,467 A 3/1980 Hatanaka
4,352,980 A 10/1982 Hibari

22 Claims, 11 Drawing Sheets

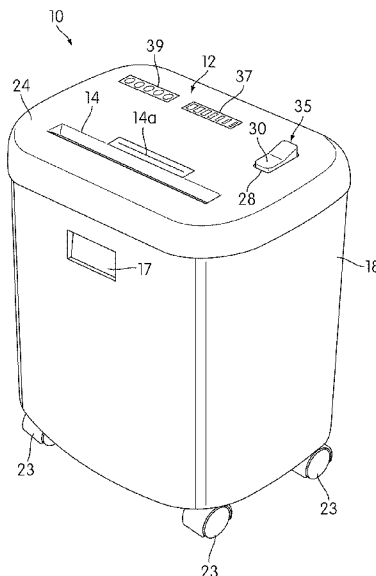

U.S. PATENT DOCUMENTS			FOREIGN PATENT DOCUMENTS		
4,707,704 A	11/1987	Allen	2004/0194594 A1	10/2004	Dils et al.
4,757,949 A	7/1988	Horton	2004/0226800 A1	11/2004	Pierga
4,814,632 A	3/1989	Glaeser	2005/0046651 A1	3/2005	Askren et al.
4,815,669 A	3/1989	Fujii	2005/0150986 A1	7/2005	Castronovo
4,842,205 A	6/1989	Araki	2005/0213106 A1	9/2005	Weijers et al.
4,889,291 A	12/1989	Goldhammer et al.	2006/0016919 A1	1/2006	Castronovo
4,890,797 A	1/1990	Fujii et al.	2006/0054725 A1	3/2006	Matlin
4,914,721 A	4/1990	Glaeser	2006/0091247 A1	5/2006	Matlin
5,017,972 A	5/1991	Daughton	2006/0243631 A1	11/2006	Duke
5,081,406 A	1/1992	Hughes et al.	2007/0007373 A1	1/2007	Matlin
5,139,205 A	8/1992	Gallagher et al.	2007/0025239 A1	2/2007	Jain et al.
5,166,679 A	11/1992	Vranish et al.	2007/0063082 A1	3/2007	Coleman
5,167,374 A	12/1992	Strohmeier	2007/0080252 A1	4/2007	Pierce
5,186,398 A	2/1993	Vigneau, Jr.	2007/0087942 A1	4/2007	Allen
5,198,777 A	3/1993	Masuda et al.	2007/0164135 A1	7/2007	Zhong
5,342,033 A	8/1994	Iwata	2007/0164138 A1	7/2007	Allen
5,345,138 A	9/1994	Mukaidono et al.	2007/0215728 A1	9/2007	Priester
5,353,468 A	10/1994	Yap	2007/0221767 A1	9/2007	Matlin
5,397,890 A	3/1995	Schueler et al.	2007/0246582 A1	10/2007	Aries et al.
5,409,171 A	4/1995	Stangenberg et al.	2007/0246586 A1	10/2007	Matlin et al.
5,415,355 A	5/1995	Gollwitzer	2008/0093487 A1	4/2008	Lee
5,429,313 A	7/1995	Schwellung	2008/0231261 A1	9/2008	Dengler et al.
5,453,644 A	9/1995	Yap	2009/0025239 A1	1/2009	Pan
5,494,229 A	2/1996	Rokos	2009/0032629 A1	2/2009	Aries et al.
5,539,322 A	7/1996	Zoughi et al.	2009/0090797 A1	4/2009	Matlin et al.
5,662,280 A	9/1997	Nishio et al.	2010/0051731 A1	3/2010	Matlin et al.
5,743,521 A	4/1998	Munakata et al.	2010/0084496 A1	4/2010	Matlin et al.
5,772,129 A	6/1998	Nishio et al.	2010/0102153 A1	4/2010	Matlin et al.
5,775,605 A	7/1998	Tsai	2010/0134805 A1	6/2010	Pan
5,823,529 A	10/1998	Mandel	2010/0170967 A1	7/2010	Jensen et al.
5,850,342 A	12/1998	Nakamura et al.	2010/0170969 A1	7/2010	Jensen et al.
5,850,588 A *	12/1998	Yoshikawa 399/327	2010/0176227 A1	7/2010	Davis et al.
5,871,162 A	2/1999	Rajewski	2010/0181398 A1	7/2010	Davis et al.
5,924,637 A	7/1999	Niederholtmeyer	2010/0213296 A1	8/2010	Sued et al.
D412,716 S	8/1999	Kroger	2010/0213297 A1	8/2010	Sued et al.
5,942,975 A	8/1999	Sorenson	2010/0213300 A1	8/2010	Matlin et al.
D414,198 S	9/1999	Iwata	2010/0243774 A1	9/2010	Hu et al.
5,988,542 A	11/1999	Henreckson	2010/0252661 A1	10/2010	Matlin et al.
6,065,696 A	5/2000	Tsai	2010/0252664 A1	10/2010	Matlin et al.
D426,805 S	6/2000	Iwata	2010/0270404 A1	10/2010	Chen
6,079,645 A	6/2000	Henreckson et al.	2010/0282879 A1	11/2010	Chen
6,116,528 A	9/2000	Schwellung	2010/0288861 A1	11/2010	Cai et al.
6,141,883 A	11/2000	Mitchell et al.	2010/0320297 A1	12/2010	Matlin et al.
6,265,682 B1	7/2001	Lee	2010/0320299 A1	12/2010	Matlin et al.
6,376,939 B1	4/2002	Suzuki et al.	2011/0272504 A1	11/2011	Matlin et al.
6,418,004 B1	7/2002	Mather et al.	2011/0272505 A1	11/2011	Matlin et al.
6,550,701 B1	4/2003	Chang	2011/0280642 A1	11/2011	Ikeda et al.
6,561,444 B1	5/2003	Yokomine et al.	2011/0297769 A1	12/2011	Matlin et al.
6,601,787 B1	8/2003	Langenecker	2011/0297770 A1	12/2011	Matlin et al.
6,655,943 B1	12/2003	Peterson			
6,666,959 B2	12/2003	Uzoh et al.	DE	4121330	1/1993
6,676,460 B1	1/2004	Motsenbocker	DE	4207292	1/1993
6,698,640 B2	3/2004	Hakozaki	DE	4237861	5/1994
6,724,324 B1	4/2004	Lambert	DE	4437348	4/1996
6,802,465 B1	10/2004	Norcott et al.	DE	19835093	2/1999
6,979,813 B2	12/2005	Avril	DE	202004000907	5/2005
6,983,903 B2	1/2006	Chang	DE	102006036136	1/2008
6,997,408 B2	2/2006	Watano	DE	202010001577 U1	11/2010
7,025,293 B2	4/2006	Matlin et al.	EP	268244	11/1987
7,040,559 B2	5/2006	Matlin	EP	0392867	10/1990
7,166,561 B2	1/2007	Allen	EP	562076	9/1992
7,210,867 B1	5/2007	Silverbrook	EP	524708	1/1997
7,213,780 B2	5/2007	Chen	EP	0792691	9/1997
7,311,276 B2	12/2007	Matlin et al.	EP	0818241	1/1998
7,520,452 B2	4/2009	Watano et al.	EP	856945	1/1998
7,624,938 B2	12/2009	Aries et al.	EP	855221	7/1998
7,631,822 B2	12/2009	Matlin et al.	EP	1177832	2/2002
7,631,823 B2	12/2009	Matlin et al.	EP	1195202	4/2002
7,631,824 B2	12/2009	Matlin et al.	EP	2180290	7/2008
7,635,102 B2	12/2009	Matlin et al.	EP	2022566	2/2009
7,661,614 B2	2/2010	Matlin et al.	GB	1199903	7/1970
7,663,769 B2	2/2010	Hayashihara et al.	GB	2171029	8/1986
7,712,689 B2	5/2010	Matlin et al.	GB	2209963	6/1989
2003/0016365 A1	1/2003	Liess et al.	GB	2440651	2/2008
2003/0042342 A1	3/2003	Kroger et al.	GB	2442942	4/2008
2004/0008122 A1	1/2004	Michael	GB	2451513	2/2009
2004/0069883 A1	4/2004	Watanabe et al.	JP	5311911	3/1978
2004/0159198 A1	8/2004	Peot et al.	JP	57-76734	1/1982

JP 57-070445 4/1982
 JP 57-070445 U 4/1982
 JP 58-223448 12/1983
 JP 59150554 8/1984
 JP 61-000702 1/1986
 JP 62183555 11/1987
 JP 63-173342 11/1988
 JP 2-277560 11/1990
 JP H2-303550 12/1990
 JP 04-157093 5/1992
 JP 04-0180852 6/1992
 JP 5-96198 4/1993
 JP H05-092144 4/1993
 JP 6-277548 10/1994
 JP 7-299377 11/1995
 JP 8-108088 4/1996
 JP 8-131861 5/1996
 JP 08-131962 5/1996
 JP 08-16434 6/1996
 JP 52-11691 1/1997
 JP 9-38513 2/1997
 JP 09075763 3/1997
 JP 09-150069 10/1997
 JP 9-262491 10/1997
 JP 10-048344 2/1998
 JP 11-216383 8/1999
 JP 11-304942 11/1999
 JP 2000346288 12/2000
 JP 2002-239405 8/2002
 JP 2002239405 8/2002
 JP 2004-321840 11/2004
 JP 2004321993 11/2004

WO 2005070553 8/2005
 WO 2006019985 2/2006
 WO 2006036370 4/2006
 WO 2007109753 9/2007
 WO 2007122364 11/2007
 WO 2007137761 12/2007

OTHER PUBLICATIONS

ACCO Rexel, Mainstream 1050/2150/2250/3150/3250 and 3350, 115V Machines Illustrated Parts Lists and Services Instructions, Mar. 25, 2002, Issue No. 4.
 ACCO Rexel, Decksides and Office 115V Machines Illustrated Parts Lists and Service Instructions, Aug. 18, 1999.
 ACCO Rexel, Decksides and Office 230V Machines Illustrated Parts Lists and Service Instructions, Aug. 1, 2000.
 GBC Shredmaster Service Manual, Part #6001054, referencing Models 2230S and 2250X Paper Shredders, Nov. 1997.
 The Stationary and Business Machines—Japan, “DS-4000 by Carl Jimuki K.K.”, Jun. 2003.
 The Stationary and Business Machines—Japan, “NSE-501CN by Nakabayashi K.K.”, Oct. 2004.
 International Search Report and Written Opinion for PCT/US2011/031922 dated Oct. 6, 2011.
 English Translation of Japanese Patent Application Publication No. 9-38513, published on Feb. 10, 1997.
 U.S. Appl. No. 60/613,750, filed Sep. 27, 2004, Pierce.
 U.S. Appl. No. 60/686,490, filed May 31, 2005, Pierce.
 U.S. Appl. No. 60/688,285, filed Jun. 7, 2005, Pierce.

* cited by examiner

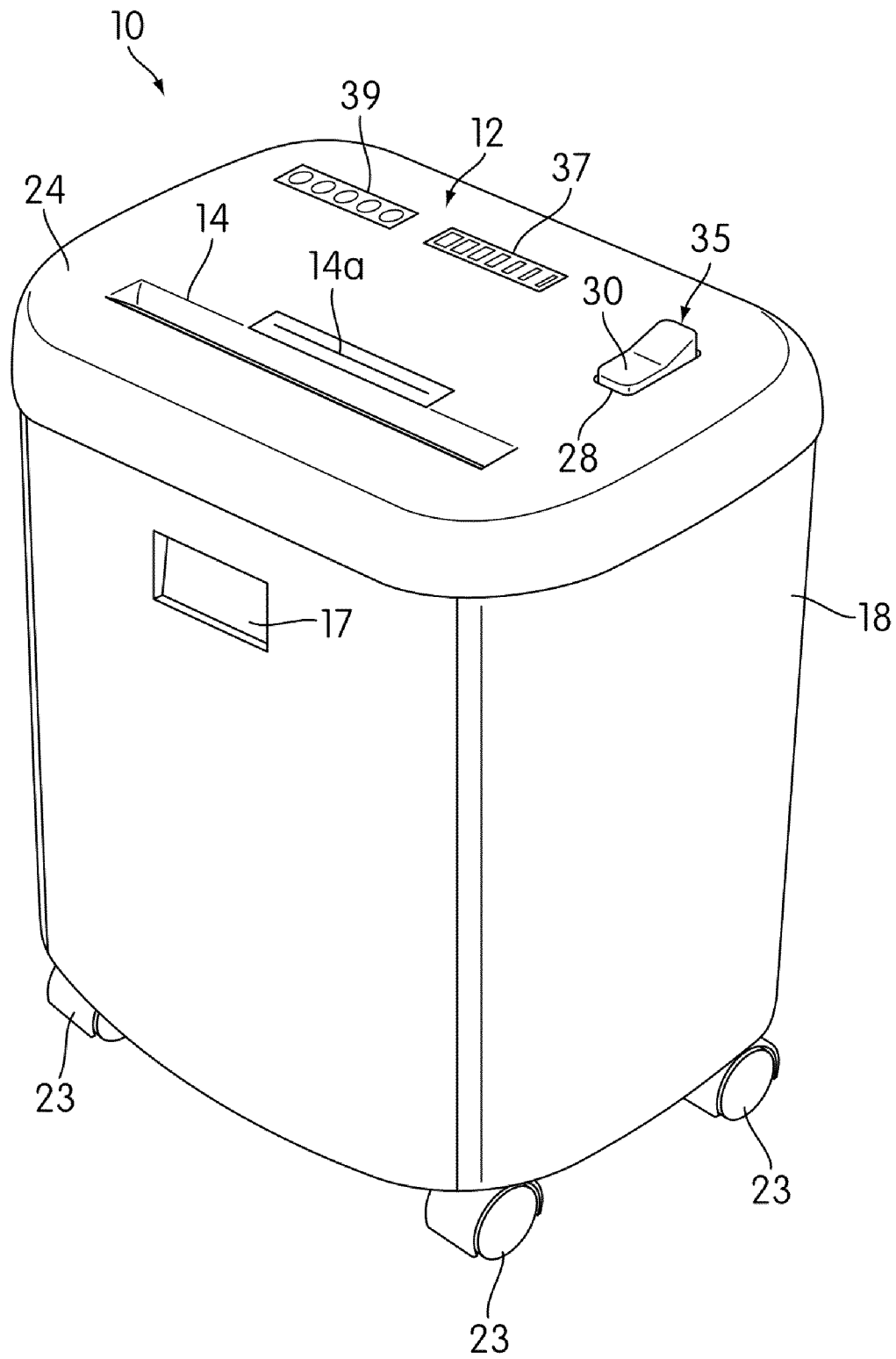

FIG. 1

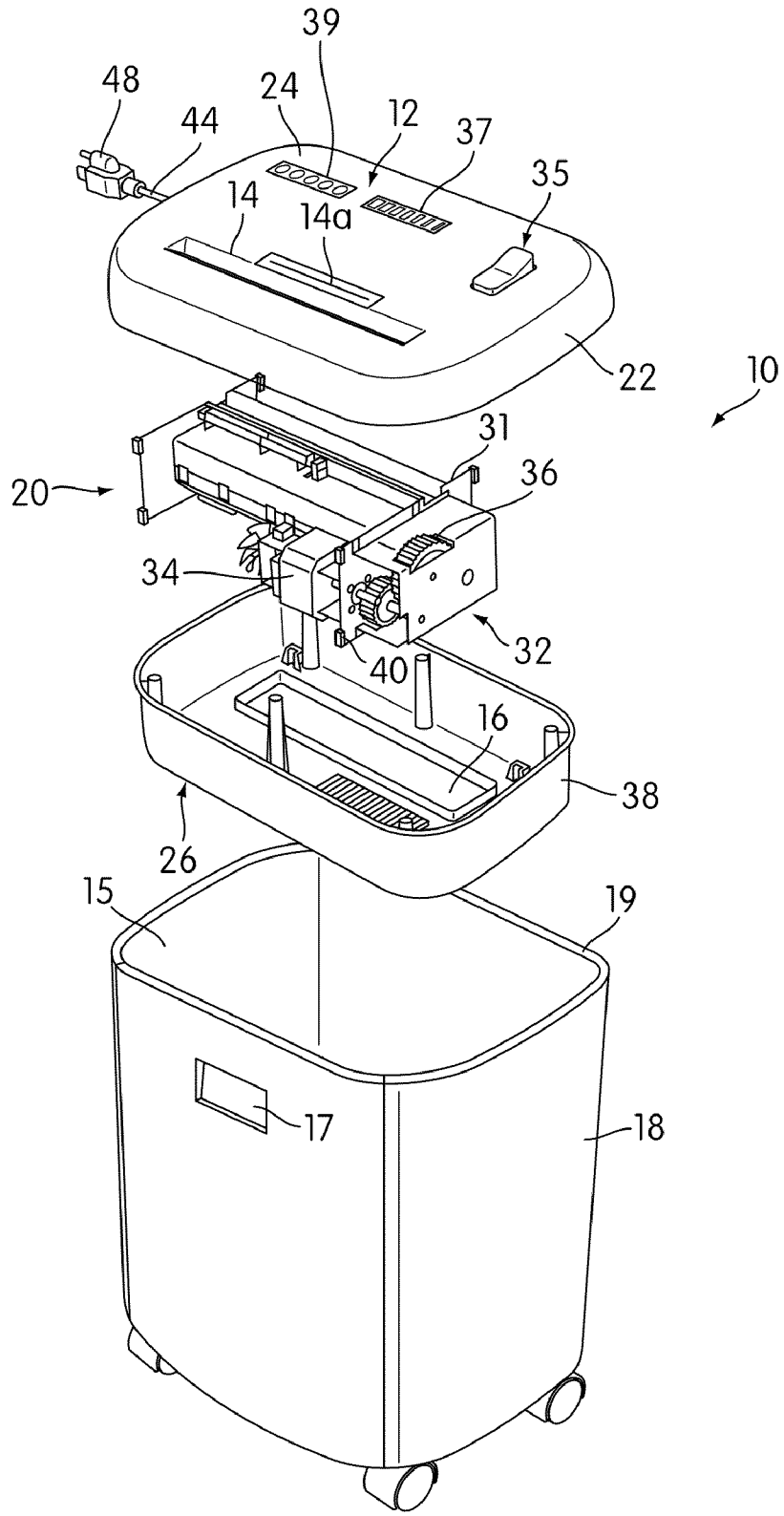

FIG. 2

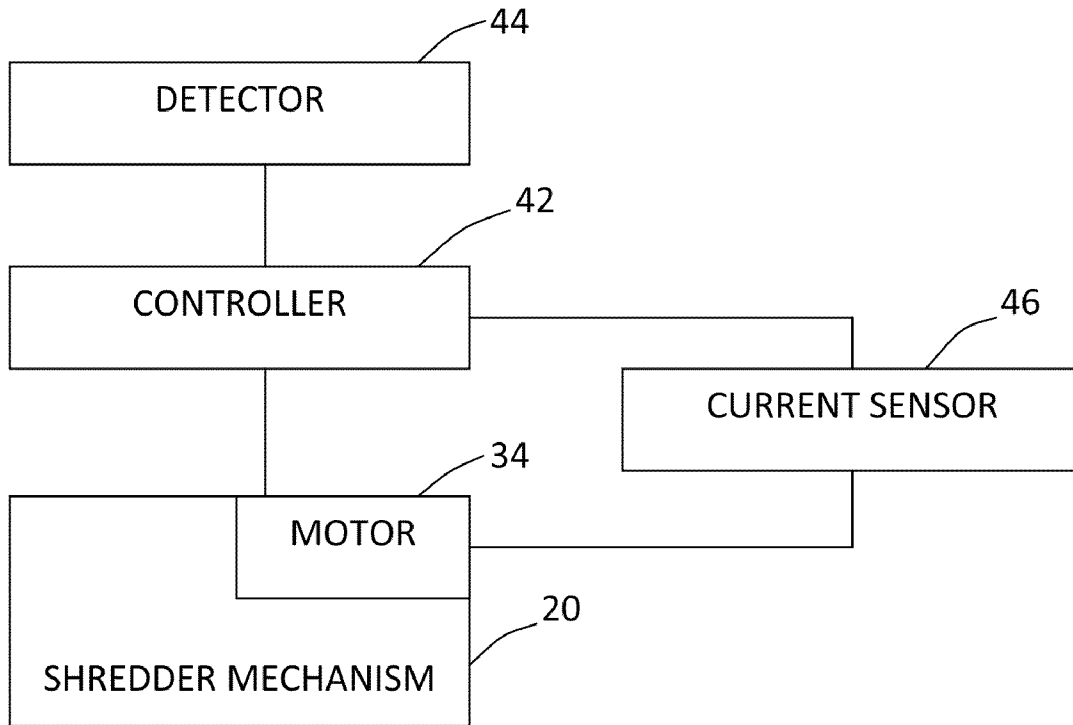

FIG. 3

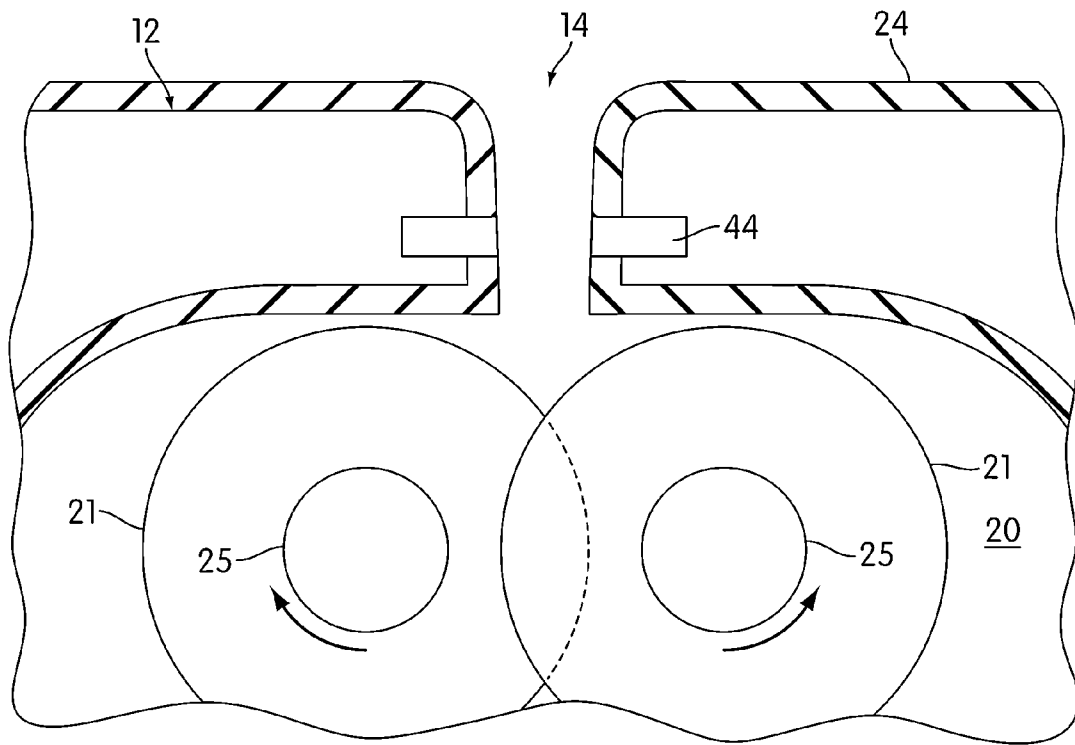

FIG. 4

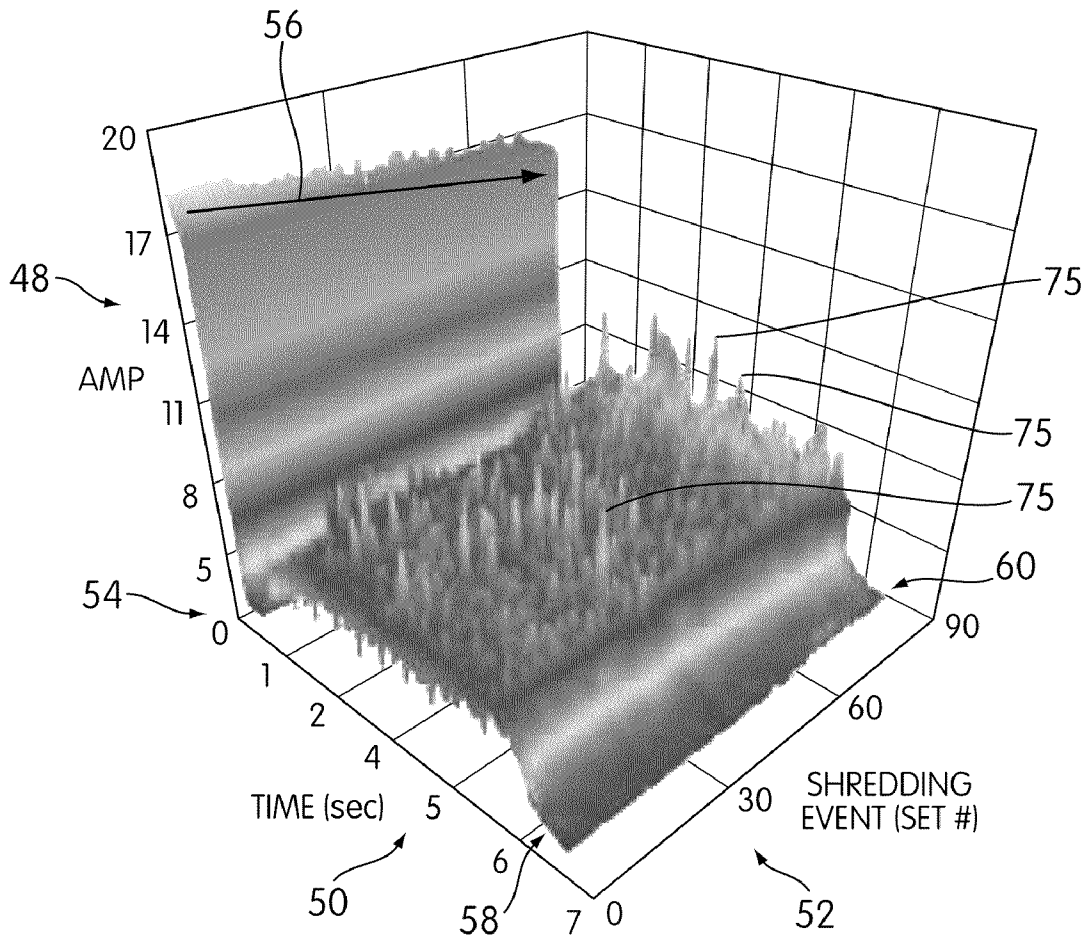

FIG. 5

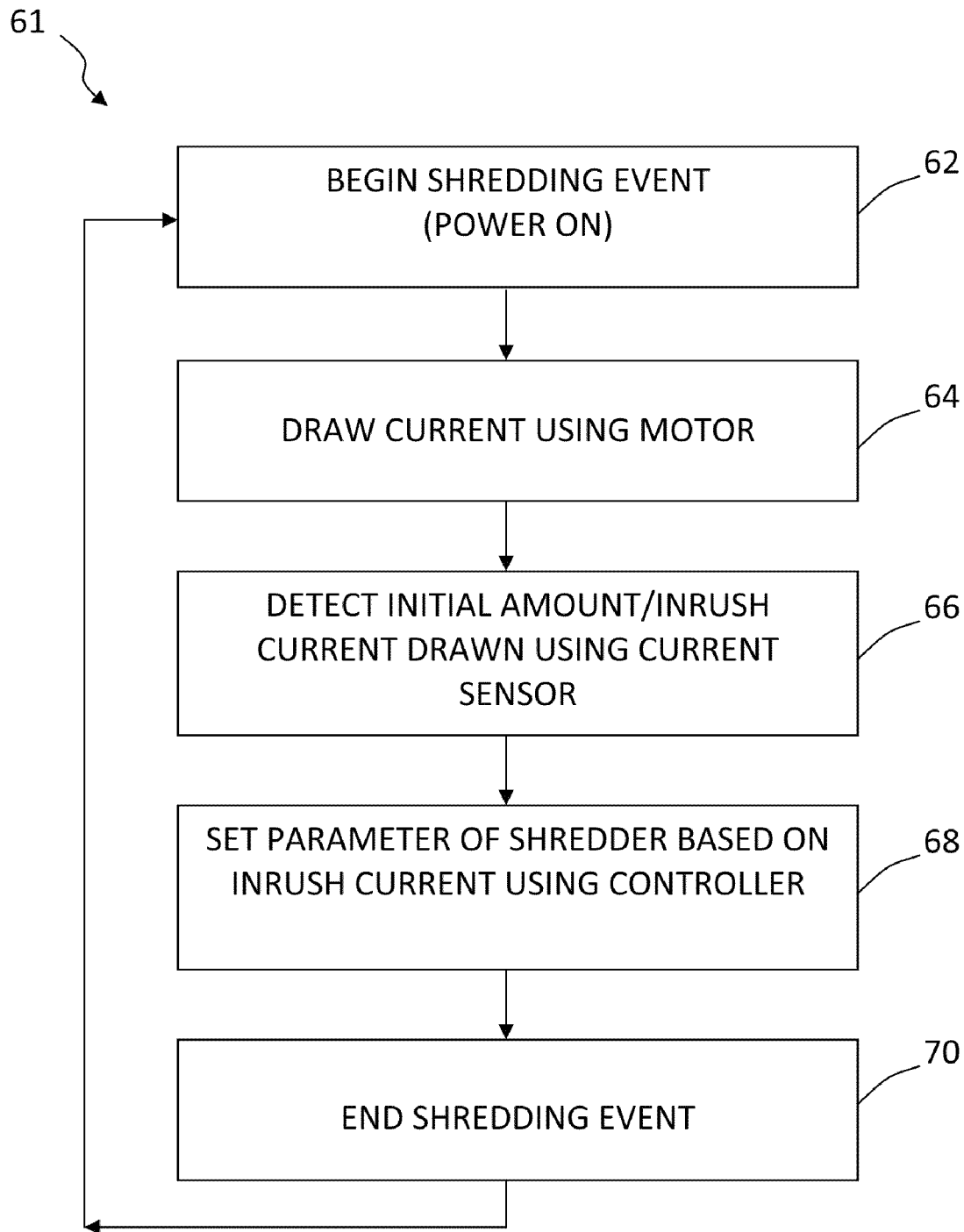

FIG. 6

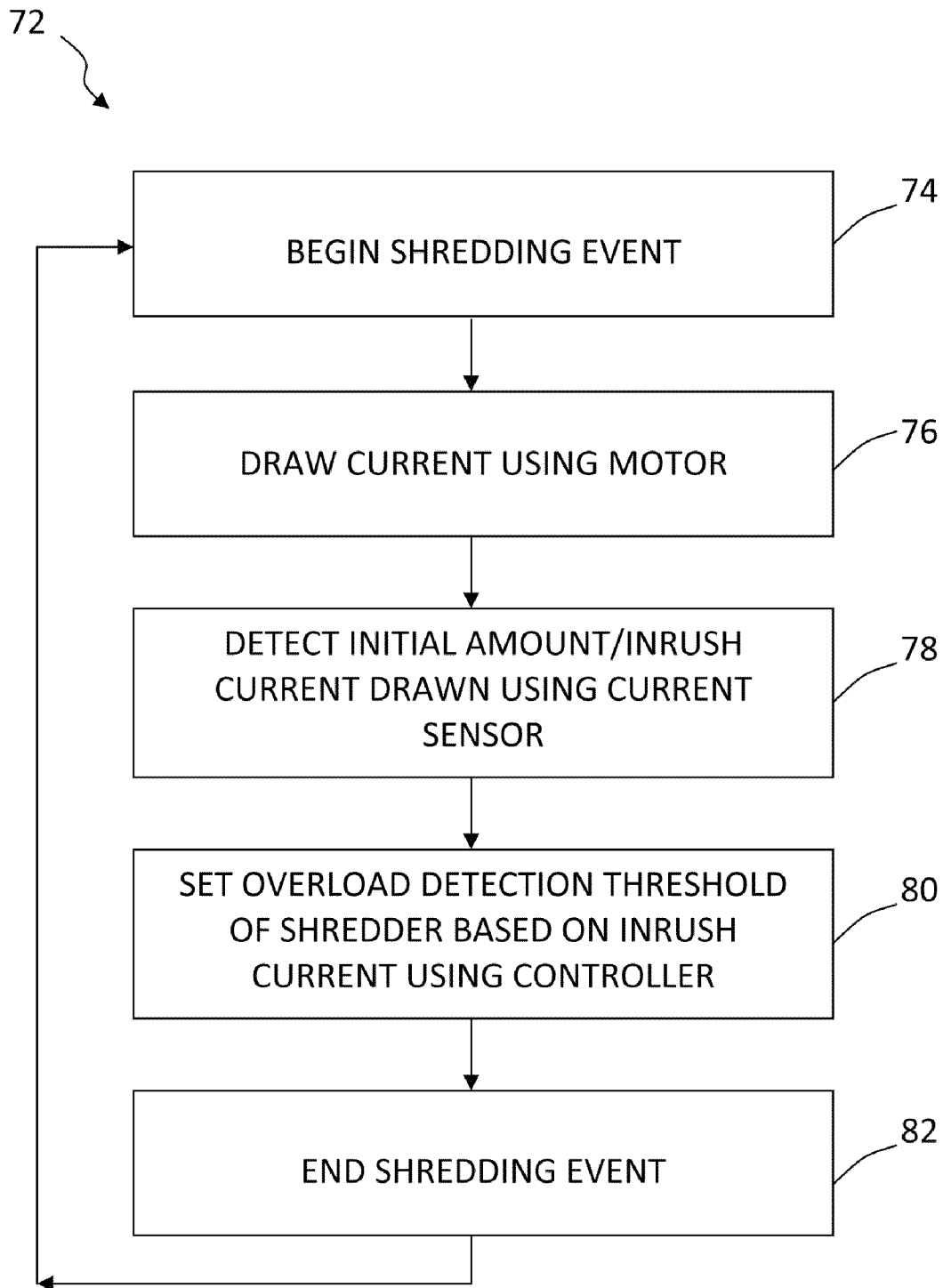

FIG. 7

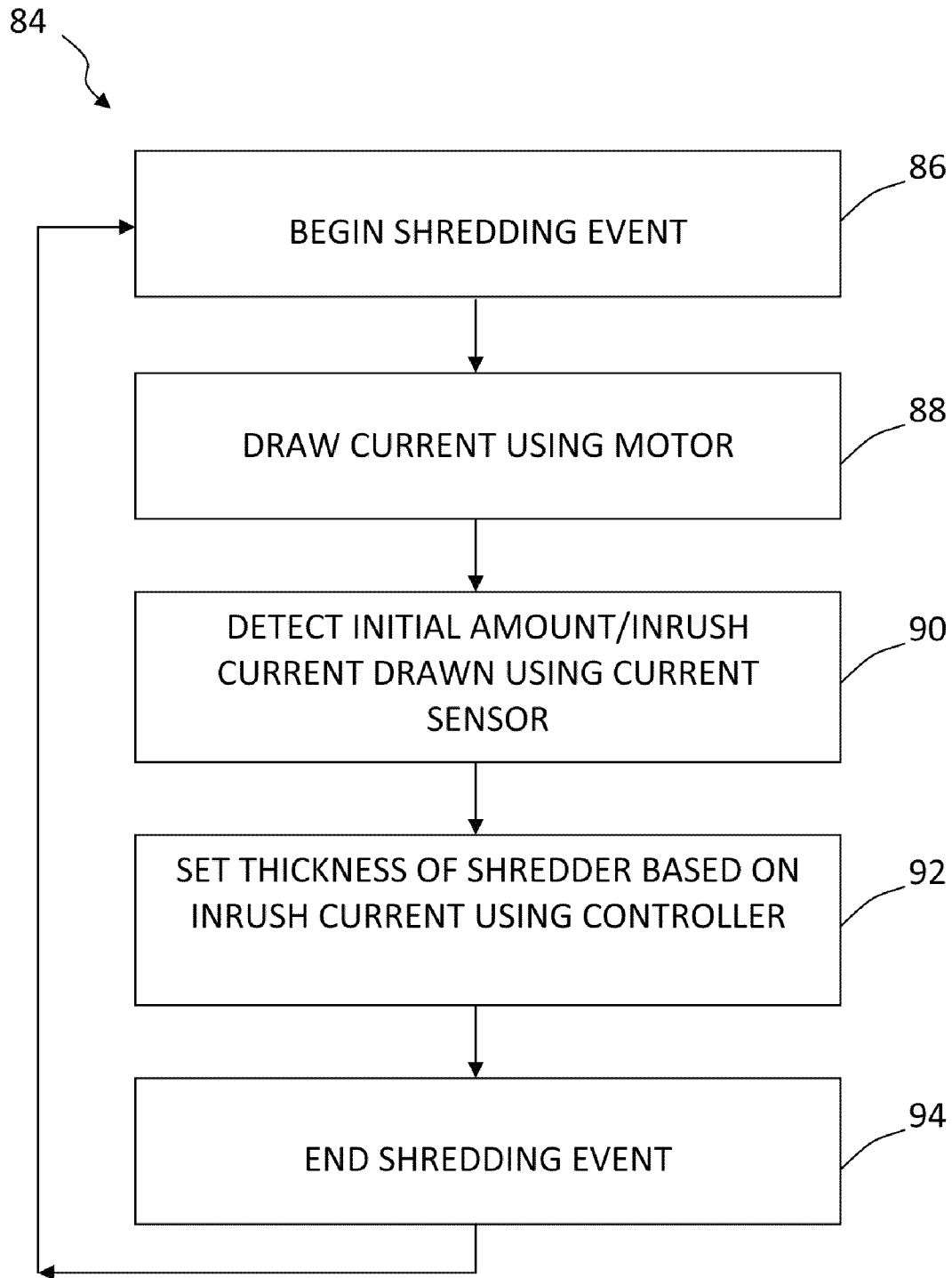

FIG. 8

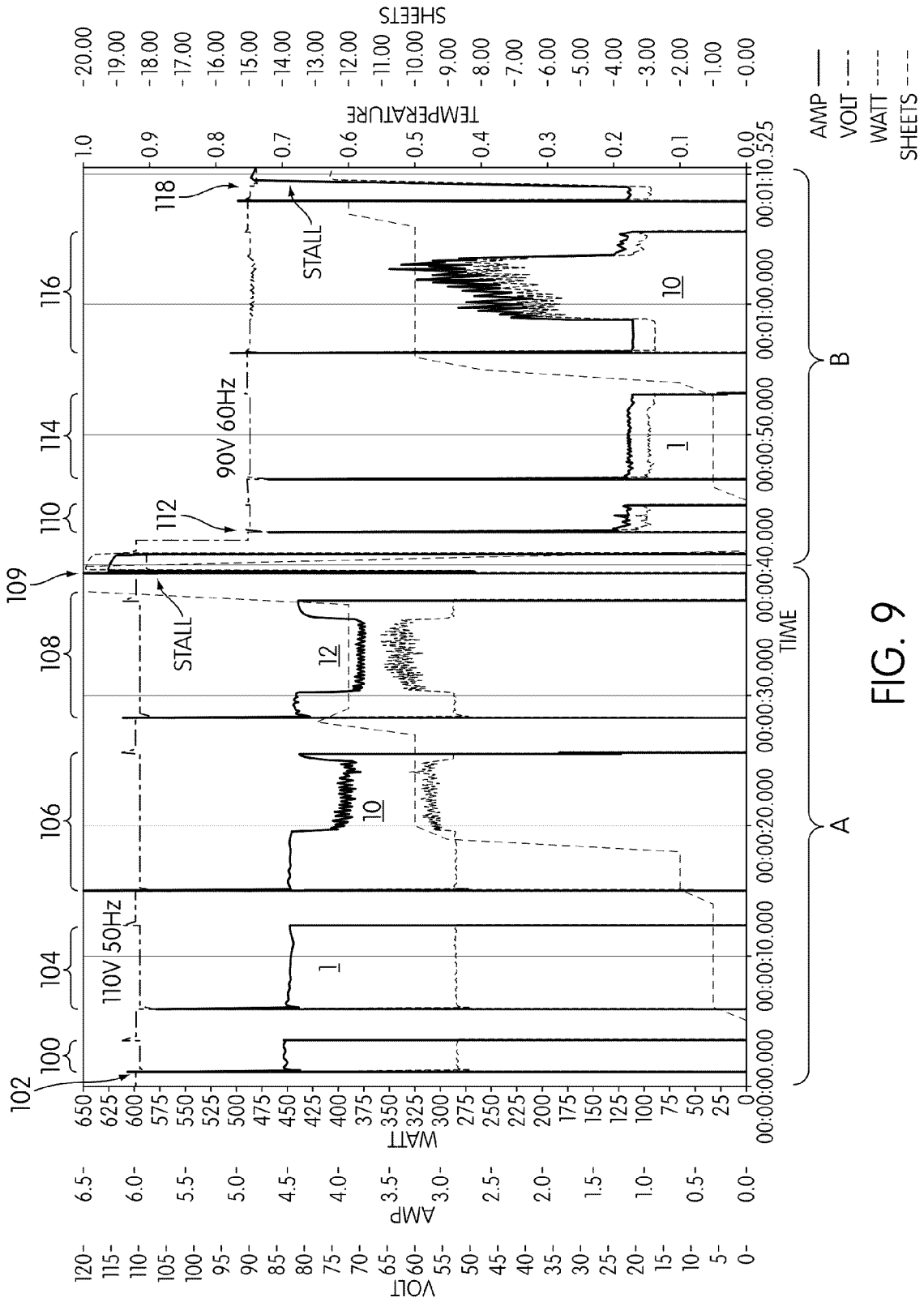

FIG. 9

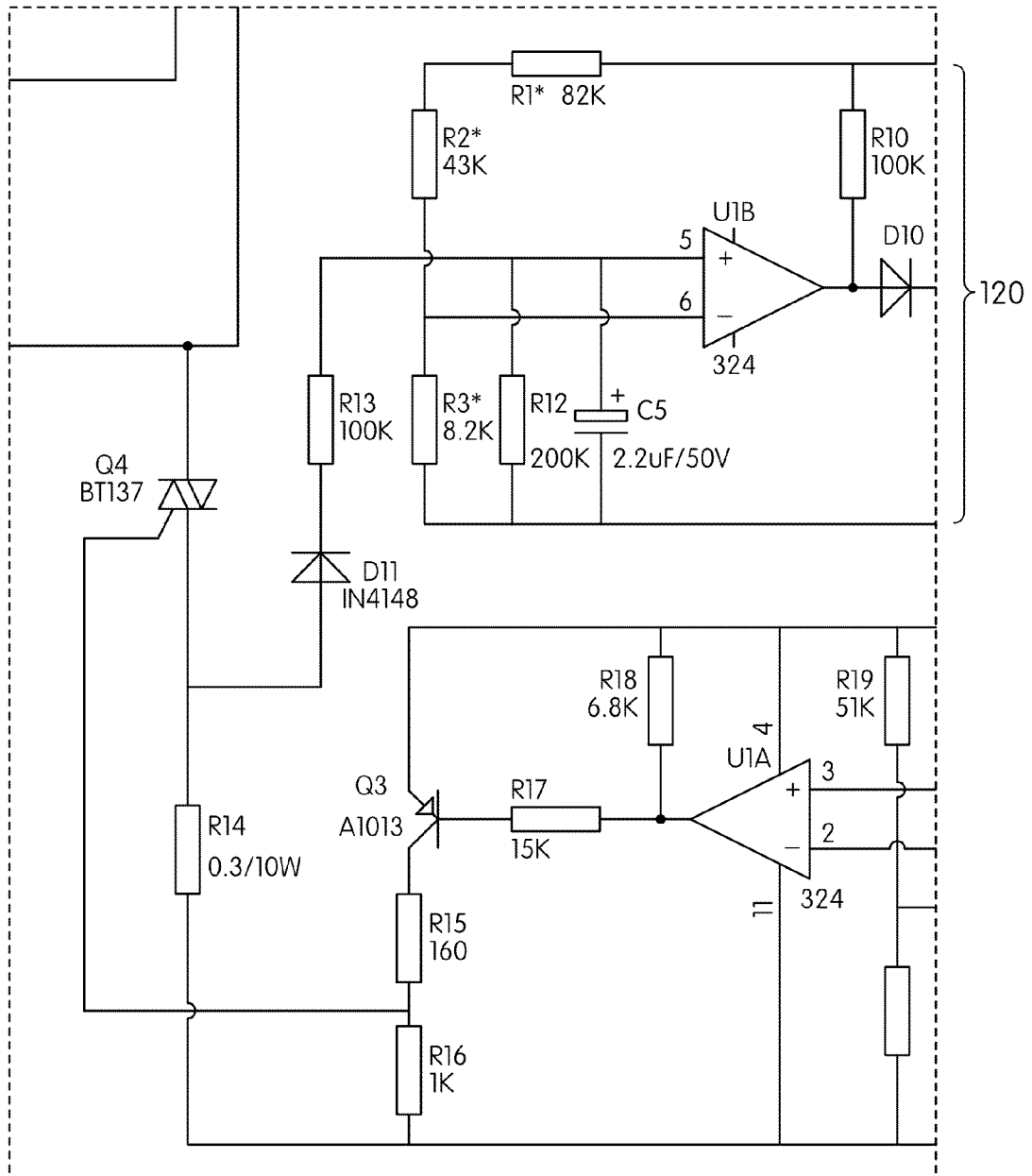

FIG. 10

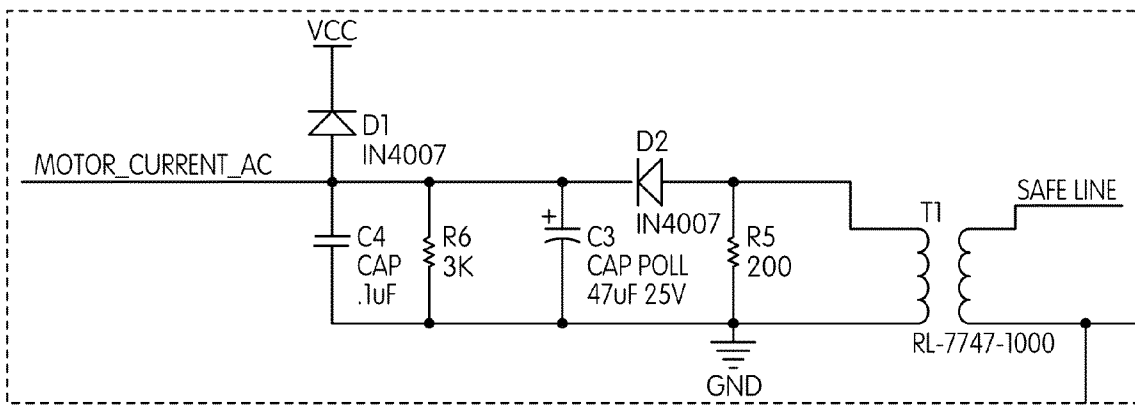

FIG. 11

IN-RUSH CURRENT JAM PROOF SENSOR CONTROL

BACKGROUND OF THE INVENTION

1. Field of Invention

The present invention relates to shredders for destroying articles, such as documents, CDs, etc.

2. Description of Related Art

Shredders are well known devices for destroying substrate articles, such as documents, CDs, floppy disks, etc. Typically, users purchase shredders to destroy sensitive articles, such as credit card statements with account information, documents containing company trade secrets, etc.

A common type of shredder has a shredder mechanism contained within a housing that is removably mounted atop a container. The shredder mechanism typically has a series of cutter elements that shred articles fed therein and discharge the shredded articles downwardly into the container. The shredder typically has a stated capacity, such as a number of sheets of paper (typically of 20 lb. weight) that may be shredded at one time; however, the feed throat of a typical shredder can receive more sheets of paper than the stated capacity. A common frustration of users of shredders includes feeding too many papers into the feed throat, only to have the shredder jam after it has started to shred the papers. To free the shredder of the papers, the user typically reverses the direction of rotation of the cutter elements via a switch until the papers become free. Occasionally, the jam may be so severe that reversing may not free the paper entirely, and the paper must be pulled out manually, which may be difficult with the paper bound between blades of the cutter elements. In some cases, when article(s) are inserted into the shredder that are too thick or irreversible, the shredder may be overloaded or overheated, and the motor of the shredder mechanism may stall and thus shut down.

In order to prevent such motor stall, some existing designs use other detection devices to anticipate a motor's current-limit. For example, such designs may include load meters (readings based on motor current), speed-based jam detectors, hall effect sensors (for reading motor speed), or other types of speed sensors (e.g., provided on the cutter shafts). In some existing cases, detection of possible overload or motor stall may be prevented by reversing the motor when the system becomes jammed. U.S. Pat. No. 4,495,456, entitled "Automatic Reversing System for Shredder," illustrates an example of such a machine.

Some shredders may employ a stall or overload detection circuit which monitors a motor's current draw to determine maximum capabilities of the shredding machine and to determine if/when a motor might stall. In such shredders, the idea is to prevent the motor from going into or remaining in a stall condition which not only draws excessive current, but also heats the motor prematurely. Traditionally, these circuits either have a delay or a limiting device (e.g., a thermistor) or have software to ignore the initial in-rush current drawn by the motor to prevent false positive reactions (for possible stalls or short-circuits).

For example, a first known traditional method for setting the overload detection threshold includes setting a fixed value close to the stall current of a machine at its cold state, and then determining if a motor's current draw is close to the fixed value (i.e., using a comparator) during operation. This first method may be effective on a "cold" motor, i.e., a motor that is not running. The overload detection circuitry of this type of shredder will only trigger when the motor is stalled/about to stall (i.e., drawn current is close to the fixed value). However,

as a motor heats during use, the amount of current being drawn by the motor tends to decrease, and AC fluctuations may occur. This first method is unable to track any decrease in drawn current as the motor heats or fluctuations. This means that a "hot" (i.e., working or rotating) motor will often stall before or without the overload detection circuitry detecting the event.

A second known method for overload detection is a calibration that is performed at the factory or during manufacture, in which a threshold of a shredder is adjusted to a specific load (e.g., sheet count) on that specific machine. This second method may be effective at preventing a user from operating above the ratings of the machine (before stalling), but it, too, can also not track variances in drawn motor current due to heat and/or AC fluctuations. This, in turn, causes the initial threshold to fluctuate, which can either allow excessive load on the system, or it can prematurely limit the user from operating the machine within its capabilities.

In other designs, assumptions have to be made using software based on time, or an extra thermal device has to be added to the motor to track motor temperature. For example, assumptions of the current thermal condition of the motor (and therefore the maximum load) could be approximated by a software algorithm. Such assumptions generally assume that all of the motors in mass-production have similar thermal characteristics and that the efficiencies of the cutting blocks are similar. However, such assumptions are generally incorrect. Although two motors (of the same model) can have similar measured temperatures, this does not equate to them having the same performance characteristics. Variances in material and assembly can change this relationship, for example. In addition, variations in line voltage and frequency are not generally accounted for. This can significantly impact the performance of the motor and impact the stall current reading relative to a fixed threshold.

As noted above, the inrush current initially drawn by a motor when a shredder mechanism is turned on is ignored in prior designs to prevent false readings of overload. However, as described further herein, this disclosure determines and uses this inrush current to determine parameters related to the motor as well as occurrences at which the motor will stall (e.g., due to a jam in the shredder).

SUMMARY OF THE INVENTION

One aspect of the invention provides a shredder having: a housing having a throat for receiving at least one article to be shredded and a shredder mechanism received in the housing and including an electrically powered motor and cutter elements. The shredder mechanism enables the at least one article to be shredded to be fed into cutter elements and the motor is operable to drive the cutter elements in a shredding direction so that the cutter elements shred the articles fed therein upon receiving electrical power via a power source. The shredder also has a current sensor for detecting current flowing through the motor and a controller coupled to the motor for controlling operation of the motor. The controller is also coupled to the current sensor and configured to detect at least an inrush current supplied to the motor for each shredding event. The controller is configured to set a parameter of the shredder based on the detected inrush current supplied to the motor.

Another aspect of the invention provides a method for monitoring operation of a shredder, the shredder comprising a housing having a throat for receiving at least one article to be shredded and a shredder mechanism received in the housing and including an electrically powered motor and cutter ele-

ments. The shredder mechanism enables the at least one article to be shredded to be fed into cutter element and the motor is operable to drive the cutter elements in a shredding direction so that the cutter elements shred the articles fed therein upon receiving power via a power source. The shredder has a current sensor for detecting current flowing through the motor, and a controller coupled to the current sensor and coupled to the motor for controlling operation of the motor. The method includes:

powering the motor with electrical power via the power source;

detecting with the controller an inrush current supplied to the motor for each shredding event, and

setting with the controller a parameter of the shredder based on the determined inrush current supplied to the motor.

Yet another aspect of the invention provides a computer program product having: a computer-usable data carrier storing instructions that, when executed by a computer, cause the computer to perform a method for monitoring operation of a shredder, the shredder including a housing having a throat for receiving at least one article to be shredded, a shredder mechanism received in the housing and including an electrically powered motor and cutter elements, the shredder mechanism enabling the at least one article to be shredded to be fed into cutter elements and the motor being operable to drive the cutter elements in a shredding direction so that the cutter elements shred the articles fed therein upon receiving power via a power source, a current sensor for detecting current flowing through the motor, and a controller coupled to the current sensor and coupled to the motor for controlling operation of the motor; the method including:

detecting with the controller an inrush current supplied to the motor for each shredding event, and

setting with the controller a parameter of the shredder based on the determined inrush current supplied to the motor.

Other objects, features, and advantages of the present invention will become apparent from the following detailed description, the accompanying drawings, and the appended claims.

BRIEF DESCRIPTION OF THE DRAWINGS

FIG. 1 is a perspective view of a shredder constructed in accordance with an embodiment of the invention.

FIG. 2 is an exploded perspective view of the shredder of FIG. 1.

FIG. 3 is a schematic illustration of an embodiment of a detector, a controller, a current sensor, and a shredder mechanism with a motor, in accordance with an embodiment of the invention.

FIG. 4 is a cross-section showing a schematic illustration of a detector and shredder mechanism in the shredder of FIG. 1 in accordance with an embodiment of the present invention.

FIG. 5 is a 3-D graph illustrating relationships between current, time, and shredding events in accordance with embodiments of the invention.

FIG. 6 is a flow diagram of a method for monitoring operation of a shredder in accordance with an embodiment of the invention.

FIG. 7 is a flow diagram of a method for setting of an overload detection threshold for the shredder.

FIG. 8 is a flow diagram of a method for setting a thickness of an article that may be accepted by the shredder.

FIG. 9 is a 2-D graph illustrating relationships between current, shredding events, thickness, and time in accordance with an embodiment of the invention.

FIGS. 10 and 11 are exemplary schematic motor current detection circuit diagrams which may be used in accordance with an embodiment of the invention.

DETAILED DESCRIPTION OF THE PREFERRED EMBODIMENT(S) OF THE INVENTION

As will become further evident in the description below, the herein described jam proof sensor is defined as a sensor that is configured to consider an initial inrush current of a motor when the motor is initially supplied with power to operate (e.g., rotate) in order to determine at what current draw the motor will stall. The initial inrush current is used to set a parameter (e.g., overload detection threshold or maximum thickness threshold) of the shredder so that stalling or overheating can be prevented (i.e., before reaching a current draw at which the motor will stop).

FIG. 1 is a perspective view of a shredder apparatus 10 constructed in accordance with an embodiment of the present invention. The shredder 10 is designed to destroy or shred articles such as paper, paper products, CDs, DVDs, credit cards, and other objects. The shredder 10 comprises a shredder housing 12 that sits on top of a container 18, for example. The shredder housing 12 comprises at least one input opening 14 on an upper side 24 (or upper wall or top side or top wall) of the housing 12 for receiving materials to be shredded. The input opening 14 extends in a lateral direction, and is also often referred to as a throat. The input opening or throat 14 may extend generally parallel to and above a shredder mechanism 20 (described below, and shown in FIG. 4). The input opening or throat 14 may be relatively narrow, so as to prevent overly thick items, such as large stacks of documents, from being fed into therein. However, the throat 14 may have any configuration. In some cases, one or more additional or second input openings 14a may be provided in shredder housing 12. For example, input opening 14 may be provided to receive paper, paper products, and other items, while a second input opening 14a may be provided to receive objects such as CDs and DVDs, credit cards, etc. The upper wall 24 may be molded from a plastic material or any other material. The shredder housing 12 and its upper wall 24 may have any suitable construction or configuration.

Shredder housing 12 also comprises an output opening 16 on a lower side 26 (or bottom side or bottom wall or underside or bin side), shown in FIG. 2. In an embodiment, shredder housing 12 may include a bottom receptacle 38 with lower side 26 to receive shredder mechanism 20 (along with a motor 34, transmissions, etc.) therein. For example, the bottom receptacle 38 may have a bottom wall forming lower side 26, four side walls and an open top. Bottom receptacle 38 is generally defined as a device or part of housing 12 for at least assisting in securing the shredder mechanism 20 within and/or to the housing 12. The bottom receptacle 38 may be molded from a plastic material or any other material. Bottom receptacle 38 may be affixed to the underside of the upper side 24 or top wall base fasteners, for example. The receptacle 38 has output opening 16 in its bottom side 26 or bottom wall through which shredded particles are discharged. Though lower side 26 is shown as comprising a bottom receptacle 38, the configuration, shape, or design of lower side 26 or receptacle 38 should not be limiting. Generally speaking, the shredder 10 may have any suitable construction or configuration and the illustrated embodiments provided herein are not intended to be limiting in any way. In addition, the term "shredder" or "shredder apparatus," used interchangeably throughout this specification, are not intended to be limited to devices that literally "shred" documents and articles, but

5

instead intended to cover any device that destroys documents and articles in a manner that leaves such documents and articles illegible and/or useless.

As noted, the shredder **10** also comprises a shredder mechanism **20** (shown generally in FIG. **2**) in the shredder housing **12**. When articles are inserted into the at least one input opening or throat **14**, they are directed toward and into shredder mechanism **20** (e.g., see FIG. **4**). “Shredder mechanism” is a generic structural term to denote a device that destroys articles using at least one cutter element. Destroying may be done in any particular way. For example, the shredder mechanism may include at least one cutter element that is configured to punch a plurality of holes in the document or article in a manner that destroys the document or article. Shredder mechanism **20** includes a drive system **32** with at least one motor **34**, such as an electrically powered motor, and a plurality of cutter elements **21** (shown in FIG. **4**). The drive system **32** may have any number of motors and may include one or more transmissions. The motor **34** may be an AC induction motor, for example. In another embodiment, the motor may be a DC motor, a permanent magnet motor, a universal motor, or any other type of motor. In the illustrated embodiment, the cutter elements **21** are generally mounted on a pair of parallel mounting shafts **25**, as shown in FIG. **4**. The motor **34** operates using electrical power to rotatably drive first and second rotatable shafts **25** of the shredder mechanism **20** and their corresponding cutter elements **21** through a conventional transmission **36** so that the cutter elements **21** shred or destroy materials or articles fed therein via throat **14**, and, subsequently, deposit the shredded materials into opening **15** of container **18** via the output opening **16**. The operation and construction of such a shredder mechanism **20** are well known and need not be described herein in detail. Generally, any suitable shredder mechanism **20** known in the art or developed hereafter may be used.

The shredder mechanism **20** may also include a sub-frame **31** for mounting the shafts **25**, motor **34**, and transmission **36** of the drive system **32** and cutter elements **21**. In some cases, the subframe **31** may be connected to both an upper side **24** (e.g., on an underside of upper side **24**) and a lower side **26** (e.g., on an upper side of receptacle **38**) to secure the shredder mechanism **20** within or to the housing **12**. For example, one or more connecting portions **40** may be provided to secure or fasten the frame **31** thereto. Generally, devices such as fasteners, screws, or bolts, and nuts may be used to secure the frame **31** to the upper side **24** and lower side **26** of housing **12**. Additionally and/or alternatively, shock absorbing elements, vibration absorbing elements, and/or springs may be used when connecting the shredder mechanism **20** and shredder housing **12**.

Also, the plurality of cutter elements **21** may be mounted on first and second rotatable shafts **25** in any suitable manner. For example, in an embodiment, the cutter elements **21** are rotated in an interleaving relationship for shredding paper sheets and other articles fed therein. In an embodiment, the cutter elements **21** may be provided in a stacked relationship. The operation and construction of such a shredder mechanism **20** is well known and need not be discussed herein in detail. As such, the at least one input opening or throat **14** is configured to receive materials inserted therein to feed such materials through the shredder mechanism **20** and to deposit or eject the shredded materials through output opening **16**.

Shredder housing **12** is configured to be seated above or upon the container **18**. The container **18** is formed of molded plastic material or any other material. The container **18** includes a bottom wall, four side walls, and an open top, for example. As shown in FIG. **2**, shredder housing **12** may

6

comprise a detachable paper shredder mechanism that sits atop container **18**. That is, in an embodiment, the shredder housing **12** may be removed in relation to the container **18** to ease or assist in emptying the container **18** of shredded materials. In an embodiment, shredder housing **12** comprises a lip **22**, seat, or other structural arrangement that corresponds in size and shape with a top edge **19** of the container **18**. The container **18** receives paper or articles that are shredded by the shredder **10** within its opening **15**. More specifically, after inserting materials into input opening **14** for shredding by cutter elements **21**, the shredded materials or articles are deposited from the output opening **16** on the lower side **26** of the shredder housing **12** into the opening **15** of container **18**. The container **18** may be a waste bin, for example.

In an embodiment, the shredder **10** may comprise roller members **23** in the form of wheels or casters to assist in moving the shredder **10**. For example, the container **18** may include wheels on its bottom (e.g., near the corners, as shown in FIG. **1**) so that the shredder **10** can be transported from one place to another.

In an embodiment, the container **18** may be positioned in a frame or a freestanding housing (e.g., formed of molded plastic or other material) beneath the shredder housing **12**. For example, the frame may be used to support the shredder housing **12** as well as comprise a container receiving space so that the container **18** may be removed therefrom. The frame may include a bottom wall, three side walls, an open front and an open top. The side walls of the frame provide a seat on which the shredder housing **20** is removably mounted. For example, in an embodiment, a container **18** may be provided to slide like a drawer with respect to a frame (e.g., a pull out bin), be hingedly mounted to a frame, or comprise a step or pedal device to assist in pulling or removing it therefrom from a front or side of the frame. Container **18** may comprise an opening, a handle, or a recess **17** to facilitate a user’s ability to grasp the bin (or grasp an area approximate to the recess **17**), and thus provide an area for the user to easily grasp to separate the container **18** from the shredder housing **12**, thereby providing access to shredded materials. The container **18** may be substantially or entirely removed from being in an operative condition with shredder housing **12** in order to empty shredded materials such as chips or strips (i.e., waste or trash) located therein. In an embodiment, the shredder **10** may comprise one or more access openings (not shown), for example, in part of the container or part of the shredder housing, to allow for the deposit of larger articles therein.

Generally the terms “container,” “waste bin,” and “bin” are defined as devices for receiving shredded materials discharged from the output opening **16** of the shredder mechanism **20**, and such terms are used interchangeably throughout this specification. However, such terms should not be limiting. Container **18** and/or frame may have any suitable construction or configuration, and the illustrated embodiment is not limiting.

Typically, the power supply to the shredder **10** will be a standard power cord **44** with a plug **48** on its end that plugs into a standard AC outlet. Also, a control panel may be provided for use with the shredder **10**. Generally, the use of a control panel is known in the art. As shown in FIG. **1**, a power switch **35** or a plurality of switches may be provided to control operation of the shredder **10**. The power switch **35** may be provided on the upper side **24** of the shredder housing **12**, for example, or anywhere else on the shredder **10**. The upper side **24** may have a switch recess **28** with an opening therethrough. An on/off switch **35** includes a switch module (not shown) mounted to housing **12** underneath the recess **28** by fastening devices, and a manually engageable portion **30**

that moves pivotally within recess **28** (i.e., a rocker switch). The switch module has a movable element (not shown) that connects to the manually engageable portion **30** to move the switch module between its states. Movement of the manually engageable portion of switch **35** moves the switch module between states. In the illustrated embodiment shown in FIG. **2**, the switch module connects the motor **34** to the power supply. This connection may be direct or indirect, such as via a controller **42** (shown in FIG. **3**). The term “controller” is used to define a device or microcontroller having a central processing unit (CPU or microprocessor) and input/output devices that are used to monitor parameters from devices that are operatively coupled to the controller **42** (e.g., field-programmable gate array). The input/output devices also permit the CPU to communicate and control the devices (e.g., one or more sensors, such as current sensor **46**, described below) that are operatively coupled to the controller **42**. The controller **42** may be one controller or comprises multiple controllers. For example, in an embodiment, each one of the multiple controllers may be provided in shredder **10** for one or more specific functions. At least one controller is coupled to current sensor **46** and/or used to detect inrush current. For example, in an embodiment, the controller may be a part of a separate, distinct system that is designed for monitoring the current sensor **46** and motor **34**. Also, the controller (and its related components) for the current sensor **42** may be added to an existing machine and/or provided at the time manufacturing. The controller **42** as shown and described is used for explanatory purposes only and should not be limiting. As is generally known in the art, the controller **42** may optionally include any number of storage media such as memory or storage for monitoring or controlling the sensors coupled to the controller.

The controller **42** likewise communicates with the motor **34** of the shredder mechanism **20**, as shown by the schematic illustration in FIG. **3**. When the switch **35** is moved to an on position, the controller **42** can send an electrical signal to the drive of the motor **34** (e.g., contacts in the switch module are closed by movement of the manually engageable portion **30** and the movable element to enable a delivery of electrical power to the motor **34**) so that it rotates the cutting elements **21** of the shredder mechanism **20** in a shredding direction, thus enabling paper sheets to be fed in the throat **14** to be shredded. Additionally or alternatively, when the switch **35** is in an on position, the switch **35** may be set to an idle, standby, or ready position, which communicates with the control panel. The idle or ready position may correspond to selectively activating the shredder mechanism **20**, for example. Such a position may allow the controller **42** to selectively enable the operation of the shredder mechanism **20** based on the detection of the presence or insertion of at least one article (e.g., paper) in the throat **14** by or based on a waste level or bin full sensing device. The switch **35** may also be moved to an off position (e.g., contacts in the switch module are opened to disable the delivery of electric power to the motor **34**), which causes the controller **42** to stop operation of the motor **34**. Alternatively, the switch may be coupled to a controller, which in turn controls a relay switch, TRIAC, etc., for controlling the flow of electricity to the motor **34**.

The switch module contains appropriate contacts for signaling the position of the switch’s manually engageable portion. As an option, the switch **35** may also have a reverse position that signals the controller to operate the motor **34** in a reverse manner. This would be done by using a reversible motor and applying a current that is of reverse polarity relative to the on position. The capability to operate the motor **34** in a reversing manner is desirable to move the cutter elements

21 in a reversing direction for clearing jams, for example. To provide each of the noted positions, the switch **35** may be a sliding switch (e.g., sliding laterally), a rotary switch, or a rocker switch. For example, in an off position the manually engageable portion and the movable element could be located generally in the center of the switch recess, and the on and reverse positions would be on opposing lateral sides of the off position. A middle or center position could be an idle or standby position. Also, the switch **35** may be of the push switch type that is simply depressed to cycle the controller through a plurality of conditions. Additionally, the controller may determine that throat **14** (e.g., via one or more sensors) is not clear of articles, and, thus, operate the motor **34** in a reverse direction (e.g., for a short period of time) so as to clear any remaining articles (or parts thereof) from the throat **14** of the shredder **10**.

Generally, the construction and operation of the switch **35** and controller **42** for controlling the motor are well known and any construction for these may be used. For example, a touch screen switch, membrane switch, or toggle switches are other examples of switches that may be used. The switch need not be mechanical and could be of the electro-sensitive type. Also, the switch need not have distinct positions corresponding to on/off/idle/reverse, and these conditions may be states selected in the controller by the operation of the switch. Likewise, such a switch may be entirely omitted, and the shredder can be started based on insertion of an article to be shredded.

Any of the conditions could also be signaled by lights, on a display screen, or otherwise. For example, in an embodiment, one or more indicators such as indicator **37** or **39** (shown in FIG. **1**) may be included to provide a warning signal to the user, such as an audible signal and/or a visual signal. In an embodiment, and as further described later, indicator **37** may comprise a sheet capacity indicator that progressively indicates the thickness of article(s) or document(s) being inserted into the opening **14** so as to prevent overloading and possible jams. U.S. Application Publication No. 20090090797 A1, Ser. No. 11/867,260, filed on Oct. 4, 2007 and assigned to the same assignee (Fellowes, Inc.), illustrates and describes such a progressive system, and is hereby incorporated by reference in its entirety. In an embodiment, indicator **39** may comprise a number of indicators corresponding to functions of the shredder, such as, but not limited to: overheating, bin open, bin full, paper jam, and flashing indicators (such as when the shredder has stopped or sensed a condition).

As shown in the schematic illustration of FIG. **3**, shredder **10** further comprises a current sensor **46** for detecting current flowing through the motor **34**. The current sensor **46** may be integrated within the controller **42** or it may be separate from the controller **42**. The controller **42** is operatively coupled to the current sensor **46** and is configured to detect at least an initial amount of current supplied to the motor **34** for each shredding event. For purposes of this disclosure, a “shredding event” is defined as a period in which electrical power is received by the motor **34** to rotatably drive the first and second rotatable shafts **25** of the shredder mechanism **20**. That is, when switch **35** is turned to an on position to rotate the shredder mechanism **20**, the shredding event begins. The shredding event ends when the motor **34** no longer receives power to rotate the shredder mechanism **20** (e.g., when the switch **35** is moved to an off position). Alternatively, the shredder mechanism **20** may be set to be selectively activated (e.g., upon detection of an article being inserted into the throat **14** by detector **44**) with the switch **35** in an idle or standby position. Even though switch **35** may be set to an idle,

standby, or ready position for selective activation, and power is being supplied to the shredder 10, power is not being used by the motor 34 to drive the shafts 25. Thus, a shredding event is not occurring. However, if the controller 24 instructs the motor 34 to activate the shredder mechanism 20, for example, upon receipt of an article in the throat 14, then the motor 34 receives electrical power and in turn rotates the shredder mechanism 20. The motor 34 may stop rotation after the article is no longer detected or after a delay period after it is no longer detected (e.g., the article has been shredded). Thus, the shredding event lasts the period from which the controller 42 controls operation of the motor 34 and power is drawn by the motor 34 to rotate the mechanism 20, until the controller 42 stops operation of the motor 34.

When a shredding event begins, the controller 42 detects an initial amount of current that is supplied to the motor 34. In the art, this initial amount of current is known as “inrush” current. Inrush current is the maximum input current drawn by an electrical device when it is first turned on or first draws power (i.e., when power is supplied to the motor 34 to rotate the shredder mechanism 20, which can be for each shredding event). The level of inrush current relative to motor stall/run may vary based on motor type, but any inductive load has an inrush. For example, FIG. 5 is an exemplary 3-D graph illustrating relationships between current (noted as 48, in Amps), time (noted as 50, in seconds (sec)), and shredding events (noted as 52, in numbers (#s)). The graph provides data relating to an AC induction motor. It is noted that the data presented throughout this disclosure is related to using an AC induction motor; however, as noted above, the methods and concepts described herein should not be limited to a specific type of motor. More specifically, FIG. 5 shows a series of shredding events using a machine such as shredder 10. At zero seconds, there is no load or power supply (i.e., zero current) drawn by the motor of the shredder mechanism, as indicated by arrow 54. When a shredding event begins, there is a large current spike—i.e., an initial or inrush current—that is supplied to/drawn by the motor, as shown by arrow 56. It is this measured or detected current that is determined (e.g., using current sensor 46) and recorded for use by the controller (further described below). When a shredding event has ended, e.g., when there is no article present in the throat and the controller instructs the motor to stop rotation of the shredder mechanism, the current gradually decreases back to zero Amps, as shown by arrows 58 and 60.

Further visual inspection of the graph of FIG. 5 shows a slight decrease in inrush current (e.g., see arrow 56) as the number 52 of shredding events occur. Inrush current is proportional to peak forward torque (e.g., feed forward torque) and inversely proportional to motor temperature. That is, as inrush current decreases, the peak forward torque decreases. In contrast, as inrush current decreases, motor temperature increases. Peak forward torque is the maximum amount of torque that a motor can deliver to a load prior to stalling. For example, for an AC induction motor, the peak torque may be approximately 80 percent (%) of the rated speed. In an AC induction motor, the peak forward torque may be a torque the motor will deliver if its shaft is prevented from turning (e.g., such as in the case of a jam in the shredder mechanism 20). Alternatively, when article(s) that are too thick are inserted into the throat of the shredder, the motor may work harder and the amount of torque required to rotate the shafts and cutter elements may increase near peak forward torque. In particular, if the motor is delivering substantially near or at peak forward torque, the motor may be overloaded to stall operation and/or the motor temperature will be greatly increased. Increases in motor temperature—due to high torques, thick

articles, repeated use, etc.—may also be more likely to cause stalling due to overheating. The inrush current is approximately equal to the peak motor stall current. Based on such information and knowing that motor stall can be a problem and/or inconvenience for users, this disclosure provides a method for measuring the inrush current for each shredding event, so that, should the inrush current change (and thus the peak forward torque and/or motor temperature at which stalls may occur will also change), the controller 42 is configured to set a parameter of the shredder 10 based on the detected initial amount of current (inrush current) supplied to the motor 34 for each shredding event.

FIG. 6 shows the method 61 for monitoring operation of shredder 10 via motor 34. At 62, a shredding event begins and power is turned on, i.e., the motor 34 is supplied with power via the power source in order to rotate the shredder mechanism 20. This may be done by the switch 35 being turned to an on position or by one or more sensors sensing an article for shredding. The motor draws current at 64. At 66, the inrush current drawn or supplied to the motor for each shredding event is determined or detected using the current sensor 46. Then, at 68, the controller 42 sets a parameter of the shredder based on the determined inrush current at 66 (if needed). The shredding event ends as shown at 70, and the process repeats for each shredding event.

In an embodiment, the parameter of the shredder may not need to be set (or reset) for each consecutive shredding event. For example, the detected inrush current for a first shredding event may be substantially equal or similar to the detected inrush current for a second, consecutive shredding event. Thus, the parameter may remain at its current setting. Also, in embodiments, two or more parameters may be set (or reset) based on the detected inrush current supplied to the motor. Logic or other algorithms may be used with the shredder 10 to make such determinations. As such, it is to be understood that the parameter examples described further below are not meant to be limiting.

The parameter set by the controller for each shredding event (if setting of such a parameter is needed) is designed to be adjusted in real-time relative to the maximum capabilities of the machine so that elements affecting the working operation of the motor 34 during shredding events are accounted or compensated for. The real-time or instantaneous adjustment of the parameter allows for a more accurate determination of when motor stalling may occur. Additional advantages of setting the parameter based on the inrush current are further described below.

In an embodiment, the parameter set by the controller 42 may be an overload detection threshold at or before which the motor will stall. That is, the overload detection threshold may be set to a limit that is substantially equal to or less than a maximum load of the motor before stalling will occur. The “maximum load” of a motor can refer to either an amount of mechanical work the motor is performing (e.g., an amount of torque applied to the shafts 25 through each revolution) or an electrical load (e.g., resistance) of the motor. The load may be affected by any number of variances (torque, temperature, frequency, etc.). Upon detection by the controller 42 that a load on the motor 34 is substantially equal to or greater than the overload detection threshold, the controller 42 is configured to limit the electrical power to the motor 34, thereby preventing the motor 34 from driving the cutter elements 21 in the shredding direction. As previously noted, the controller is configured to adjust or set the overload detection threshold based on the detected inrush current for each shredding event in real-time. FIG. 7 is a flow diagram of a method 72 for setting of this overload threshold. As shown in FIG. 6, the

method 72 of FIG. 7 begins with a shredding event at 74, i.e., the motor 34 is supplied with power via the power source in order to rotate the shredder mechanism 20. The motor draws current at 76. At 78, the inrush current drawn or supplied to the motor for each shredding event is determined or detected using the current sensor 46. Then, at 80, the controller 42 sets the overload detection threshold of the shredder based on the determined inrush current at 78 (if needed). The shredding event ends as shown at 82, and the process repeats for each shredding event.

The method or algorithm used to set the overload detection threshold should not be limiting. In an embodiment, the overload detection threshold may be directly or indirectly set based on the inrush current detected. In an embodiment, the overload detection threshold is set at a fraction of the detected inrush current. For example, if the detected inrush current is detected and records to be 17 Amps, the overload detection threshold may be set at a percentage (e.g., approximately 90% (-15.5 Amps) or approximately 70% (-12 Amps)), so that the motor will be reduced or prevented from drawing its peak motor stall current.

By monitoring, in real time, the peak inrush current of the motor for each shredding event, the herein disclosed system and method can effectively determine the maximum capability of the motor at a given instant. The system and method eliminate design assumptions and limitations typically set by using fixed limits or factory calibration methods for overload detection, as described in the Related Art section. For example, in the previously described two traditional methods, during manufacture and/or before distribution, the threshold either has to be calibrated on the line, or a fixed value has to be established during the design phase. Calibrating on the production line requires paper (waste), and introduces margin for error. The shredder 10 does not require the need for a shredding operation (e.g., shredding paper with shredder mechanism 20) at the factory in order to set the current limit threshold (as may be the case in some prior art methods), because the current limit threshold is set based on the inrush current detection. Also, using a fixed current limit setting does not compensate for variability during cutting block assembly. For example, as shown in FIG. 5, the inrush current (and thus the peak motor stall current) may change during operation of the shredder 10. By tracking this change, the limitations of the machine can be observed and one or more parameters of the shredder 10 can be adjusted accordingly.

Using the herein described method and devices also eliminates the need for additional components or sensors for sensing performance characteristic(s) of the motor 34. The system will know the capabilities of the machine regardless of other characteristics. For example, the shredder 10 automatically compensates for motor heat, line voltage, frequency variations, as well as for component tolerances and assembly variances. There is no need for a motor temperature sensor to detect the temperature of the motor, because the overload detection threshold is set based on the inrush current, and the motor would not reach a peak temperature before this threshold. Of course, although such sensors are not required, in an embodiment, the shredder 10 may include one or more sensors (not shown) for sensing a performance characteristic (e.g., temperature) of the motor 34. Monitoring such a performance characteristic is generally known in the art and therefore is not explained in detail herein.

From a development/sales point of view, this system and method may be beneficial when developing shredders for those markets which operate in both 50 & 60 Hertz (Hz) frequencies (e.g., such as in Japan). As shown and described with reference to FIG. 7, for example, changes in frequency

and voltage affect the amount of current and power used by the machine. Because the overload threshold parameter is set based on the inrush current, the peak motor stall current will not be affected by these fluctuating characteristics.

In addition to or as an alternative to setting the overload detection threshold, in an embodiment, the parameter set by the controller 42 may be a maximum thickness threshold for shredding articles with the shredder mechanism 20. The controller 42 is configured to adjust the maximum thickness threshold based on the detected initial (inrush) current for each shredding event, i.e., instantaneously in real time. The maximum thickness threshold can be altered (e.g., reduced) to reflect any loss in shredder capability over time and/or to compensate for the performance of the shredder 10. Based on the drift of the peak inrush (as shown by arrow 56 in FIG. 5), the parameter at which a detector determines that an article is too thick be automatically adjusted. FIG. 8 is a flow diagram of a method 84 for setting a thickness of an article that may be accepted by the shredder 10. The method 84 of FIG. 8 begins with a shredding event at 86, i.e., the motor 34 is supplied with power via the power source in order to rotate the shredder mechanism 20. The motor draws current at 88. At 90, the inrush current drawn or supplied to the motor for each shredding event is determined or detected using the current sensor 46. Then, at 92, the controller 42 sets the maximum thickness threshold of the shredder based on the determined inrush current at 90 (if needed). The shredding event ends as shown at 94, and the process repeats for each shredding event.

The graph in FIG. 5 shows a number of spikes labeled as 74 that occur during the period of time of the shredding events. These spikes 74 indicate that additional current is being supplied or drawn by the motor 34. Such spikes 74 may occur due to an increase in an article's thickness during shredding, such due to paper folds or creases that may occur during feeding, or due to one or more additional articles/pages being added to the throat as the article is pulled into the cutter elements 21 during shredding. When thicker articles are inserted into the throat 14, or when additional articles are added to the throat 14 that increase the thickness, the shredder mechanism 20 becomes more susceptible to jams. Moreover, if a jam does occur, and the motor 34 can not reverse its direction, the motor is likely to stall due to any one or more of reaching peak forward torque, peak current limit, peak temperature, etc.

Determining or tracking the time between successive shredding events can allow for adjustment of the thickness settings (e.g., if multiple successive passes have occurred). In another embodiment, adjustment(s) of the thickness setting are made directly according to variations in the inrush current (e.g., based on percentage changes from an initial reading (stored in memory) to a second reading).

FIG. 7 is a 2-D graph illustrating relationships between current, shredding events, thickness of articles, and time for an exemplary shredder. Using this shredder, a first run A of shredding events were performed at 110 volts and at a frequency of 50 Hz and a second run B of shredding events were performed at 90 volts and at a frequency of 60 Hz using an AC induction motor. As previously noted, some markets runs machines using both frequencies. However, it is to be understood that the same effects described below would apply to a steady voltage and frequency rate.

In first run A, when power is turned on at 100, there is an initial inrush current 102 of approximately 6 Amps and current is briefly drawn at approximately 4.5 Amps before stopping. A first shredding event 104 is run, indicating the same approximate initial inrush current of 6 Amps. The first shredding event 104 was performed using a single (1) sheet of paper for shredding by the shredder mechanism. As shown,

during shredding, the current and power (here measured in Watts) remain substantially steady (the current remains substantially close to 4.5 Amps) during the shredding of the single sheet of paper, before dropping off at the end of the shredding event.

A second shredding event **106** is run using ten (10) sheets of paper. The initial inrush current is higher (i.e., approximately 6.5 Amps) for this shredding event **106**. During the period of the shredding event, the current drawn by the motor sags or drops below 4.0 Amps. This is a result of poor power factor and the motor being run at an unsatisfactory or abnormal voltage/frequency (i.e., 110V, 50 Hz). While the current decreases, the power slightly increases. Then, just before the end of the shredding event, the current again increases to approximately 4.5 Amps before dropping to zero.

The third shredding event **108** is run using twelve (12) sheets of paper. Here the initial inrush current is approximately 6.0 Amps. Like the previous shredding event, during the period of the shredding event, the current drawn by the motor sags or drops (again, below 4.0 Amps), and the power further increases. In the illustrated embodiment, the current then again increases to approximately 4.5 Amps after shredding due to run-on (i.e., a no load operation of the motor for a time period (e.g., approximately 2 seconds) to clean the cutter elements). Thereafter, once the motor is stopped or turned off, the current and power may be dropped to zero.

Such a load (12 sheets or more) may cause potential overload of the motor. A spike of current caused at stall is shown generally at **109** as a high-current peak that lasts approximately 1 second. Also shown in an inrush spike. In this illustration, it can generally be seen that the inrush spike is relatively larger but shorter in duration as compared to the stall spike.

In second run B, the current drawn by the motor and power used is much lower at this voltage and frequency. When power is turned on at **110**, there is an initial inrush current **112** of approximately 5 Amps and current is briefly drawn at approximately 1.25 Amps before stopping. A first shredding event **114** is run, indicating the same approximate initial inrush current of 5 Amps. The first shredding event **114** was performed using a single (1) sheet of paper for shredding by the shredder mechanism. As shown, during shredding, the current and power (here measured in Watts) remain substantially steady (the current remains substantially close to 1.25 Amps) during the shredding of the single sheet of paper, before dropping off at the end of the shredding event.

A second shredding event **116** is run using ten (10) sheets of paper. The initial inrush current is slightly higher (i.e., approximately 5.25 Amps) for this shredding event **116**. During the period of the shredding event, the current drawn by the motor increases from approximately 1.25 Amps to numerous current spikes between 2.0 and 3.5 Amps. This is a result of the load on the motor. Thereafter, the current and power may be dropped to zero.

Such a load (10 sheets or more) at this frequency and power may cause potential overload of the motor. A spike of current caused at stall is shown generally at **118** as a high-current peak that lasts approximately 1 second. Also shown in an inrush spike. The inrush and stall spikes in this run are relatively close because paper was already in the throat when the machine was turned on during testing, so the machine went right from in-rush to stall.

Such a load (10 sheets or more) may cause potential overload of the motor. A spike of current caused at stall is shown generally at **109** as a high-current peak that lasts approximately 1 second. Also shown in an inrush spike (which is relatively larger but shorter in duration as compared to the

stall spike). In this illustration, it can generally be seen that the stall spike at is slightly greater than the inrush spike of current.

It is noted that in the particular example shown in FIG. 7, the power factor of the tested motor was less when run at 50 Hz as compared to the 60 Hz function of the same motor (which may be likely due to flux saturation in the windings, for example). For this reason, the 50 Hz signals sag from no-load while shredding, while at 60 Hz, the current increases during shredding. Other motors may produce alternate results for current load during shredding; however, the inrush current and stalling concepts will be similar.

As shown in each of the runs A and B, an increase in thickness of the article (the paper itself or the number of sheets) can affect the motor drawn current during a shredding event. Thus, setting or adjusting a maximum thickness threshold in real time relative to the motor's characteristics (e.g., peak torque) can prevent possible motor stalls.

For example, using both runs A and B of FIG. 9 as an exemplary guide, the measured peak inrush is virtually on the stall current. The measured inrush current in these cases may be approximately 90 to 95 percent (%) of the measured stall current (or vice versa). For a typical system, it is known to designate an 'x' amount of sheets to trigger current limit rather than allowing the system to go to full stall. For example, if a sheet thickness is approximately to be about 0.1 mm, the thickness capacity may be set to no greater than 1.0 mm, or 10 sheets. Depending on the desired sheet count considered acceptable for shredding, the percentage could be adjusted, i.e., the thickness parameter setting can be adjusted. For example, referring to FIG. 9, in an embodiment, it may be desirable to trigger the system as being at capacity at a nominal voltage/frequency, e.g., approximately 75-50% of the inrush current. By adjusting this percentage parameter, the amount of load to the system before triggering a current limit can be detected.

It is noted that the percentage or parameter may vary based on different cutting blocks (different sized motors, gearing, etc.) and a desired trigger point(s). Therefore, in embodiments, the parameters set by the controller may be defined on a per-project or per-machine basis.

Thus, because the thickness threshold or capacity may be adjusted, it is to be understood that in an embodiment, one or more detectors **44** may also be provided in the shredder, as shown in FIG. 3. Detector(s) **44** are coupled to the controller **42**. In an embodiment, a detector **44** may be provided to detect at least one article received in the throat. In an embodiment, a detector **44** may be a thickness detector configured to detect a thickness of the at least one article. For example, the thickness detector **44** may be provided in or adjacent the throat **14** of the shredder. The assignee of this application, Fellowes, Inc., has developed thickness sensing technologies for shredders. By sensing thickness of paper or articles being fed into the shredder, the shredder can be stopped (or not started) before a severe jam occurs. U.S. Pat. Nos. 7,631,822, 7,631,824, 7,635,102, and 7,631,823 and U.S. Patent Application Publication Nos. 2006/0054725 A1, 2009/0090797 A1, and 2007/0221767 A1 disclose, among other things, a detector that can determine if an overly thick object is being inserted in a shredder throat. See also, U.S. patent application Ser. Nos. 12/616,567 (U.S. Patent Application Publication No. 2010/0051731 A1), 12/579,905, 12/578,292 (U.S. Patent Application Publication No. 2010/0084496 A1), 12/409,896, 12/466,775, 12/487,220, 12/348,420 and 11/770,223 (U.S. Patent Application Publication No. 2007/0246586 A1) also owned by Fellowes, Inc. as detectors that may be used. Other examples of known shredders with thickness sensing features

designed to prevent the cutter elements from jamming are U.S. Patent Application Publication Nos. 2009/0025239 A1, 2007/0246582 A2, and 2009/0032629 A1. U.S. patent application Ser. No. 12/790,517, filed May 28, 2010, is also an example of a thickness sensor that may be used with shredder **10** and may be set in real-time based on the detected inrush current. Each of the references provided herein are incorporated by reference in their entirety and are not meant to be limiting.

As is described in the above references, if a detector **44** determines that the thickness of an article in the throat **14** is substantially equal to or great than the maximum thickness threshold (e.g., there are too many sheets or pages), the controller **42** is used to stop or prevent the motor **34** from driving the cutter elements **21** in the shredding direction. Likewise, the controller **42** can stop the current flow to the motor **34**.

In an embodiment, the thickness of the shredder may not need to be set (or reset) for each consecutive shredding event. For example, the thickness may remain at its current setting based on the detected inrush current of two consecutive shredding events. Logic or other algorithms may be used with the shredder **10** to make such determinations.

FIGS. **10** and **11** are exemplary schematic motor current detection circuit diagrams which may be used in accordance with an embodiment of the invention. The circuit diagram of FIG. **10** shows the use of a current sensor in the form of a resistor **R14** and an op-amp circuit to monitor the current. As the current passes through the TRIAC **Q3** and thus resistor **R14**, a voltage is generated. The diode half-wave **D11** rectifies the voltage to make it a DC output voltage (which is readable by processors or CPUs, such as those in controller **42**). Then a conditioning circuit **120** is used to filter and amplify the circuit.

The circuit diagram of FIG. **11** shows the use of a current sense transformer **T1**. The current passes through transformer **T1** through the primary windings (on the right side) and a burden resistor **R5** turns the current through the secondary windings (on the left side) of the transformer into a voltage. The diode **D2** is used to half-wave rectify the signal to give a DC output. The resistor and capacitor networks are used to smooth the signal to eliminate AC content. For example, if 25 Amps is passed through the primary windings, then with a 1000:1 turn ratio, the secondary windings would give 0.025 Amps at the output. When that current passes through a 200 ohm resistor, 5 volts would be achieved. The processor (or controller or computer) would see that voltage, less the diode drop, and less the filtering loss from the RC network (dependant upon line frequency).

Of course it is to be understood that, in correlation with the thickness detector **44**, in some embodiments, the shredder **10** may further comprise an alarm indicator system, and the predetermined operation (e.g., performed by the controller **42**) is alerting the user via the alarm indicator system. For example, in an embodiment, upon detecting that the article(s) inserted into the throat **14** exceed the predetermined maximum thickness threshold, the controller **42** may communicate with an indicator such as indicator **37** or **39** (shown in FIG. **1**) to provide a warning or alarm signal to the user. This signal may be an audible signal in which the controller **42** sounds an audible alarm and/or a visual signal, wherein the controller **42** may illuminate a visual indicator. Examples of audible signals include, but are not limited to, beeping, buzzing, and/or any other type of signal that will alert the user via sound(s) that the article or document that is about to be shredded is above a predetermined maximum thickness threshold, and may cause the shredder mechanism **20** of the shredder **10** to jam. This gives the user the opportunity to

reduce the thickness of the article, or to reconsider forcing the article into the throat **14** and through the shredder, knowing that any such forcing may jam and/or damage the shredder.

In an embodiment, a visual signal, indicating that an article such as article **122** is too thick, may be provided in the form of a red warning light, which may be emitted from an LED, using indicator **37**, for example. It is also contemplated that a green light may also be provided to indicate that the shredder **10** is ready to operate. In an embodiment, an indicator **37** may be used which is a progressive indication system that includes a series of indicators in the form of lights to indicate the thickness of the stack of documents or other article relative to the capacity of the shredder is provided. For example, the progressive indication system may include one or more green lights, a plurality of yellow lights, and one or more red light. The green light(s) indicate that the detected thickness of the item (e.g. a single paper, a stack of papers, a compact disc, a credit card, etc.) that has been placed in the throat **14** of the shredder **10** is below a predetermined thickness and well within the capacity of the shredder. The yellow lights provide a progressive indication of the thickness of the item. In an embodiment, a first yellow light, located next to the green light, would be triggered when the detected thickness is at or above a first predetermined thickness, but below a second predetermined thickness that triggers the red light(s). If there is more than one yellow light, each additional yellow light may correspond to thicknesses at or above a corresponding number of predetermined thicknesses between the first and second predetermined thicknesses. The yellow lights may be used to train the user into getting a feel for how many documents should be shredded at one time. The red light(s) indicate that the detected thickness is at or above the second predetermined thickness, which may be the same as the predetermined maximum thickness threshold, thereby warning the user that this thickness has been reached. U.S. Application Publication No. 20090090797 A1, Ser. No. 11/867,260, filed on Oct. 4, 2007 and assigned to the same assignee (Fellowes, Inc.), illustrates and describes such a progressive system, and is hereby incorporated by reference in its entirety.

Similarly, the aforementioned indicators of the progressive indicator system may be in the form of audible signals, rather than visual signals or lights. For example, like the yellow lights described above, audible signals may be used to provide a progressive indication of the thickness of the item. Also, in an embodiment, the visual and audible signals may be used together in a single device. Also, other ways of indicating progressive thicknesses of the items inserted in the throat **14** may be used, and the illustrations and descriptions of indicator **37** should not be limiting.

Other embodiments include incorporating the above method into a computer program product or a set of computer executable instructions readable by a computer and stored on a data carrier or otherwise a computer readable medium, such that the method **61** is automated. In a possible embodiment, the method may be incorporated into an operative set of processor executable instructions configured for execution by at least one processor or a controller or computer. The instructions may be incorporated or added to an existing shredder. In an embodiment, it is envisioned that the controller **42** may comprise program code of machine or processor executable instructions in a memory that, when executed, instructs the controller **42** to perform the method of monitoring the shredder, to operate the shredder **10**, detect at least an inrush current and/or set a parameter of the shredder **10**. The controller **42** processes the instructions and subsequently applies them by detecting the inrush current and setting the parameter. FIG. **6** shows a flow chart of such computer readable instructions.

For example, in an embodiment, when the executable instructions are executed by a computer or processor, they cause a computer or processor to automatically perform a method for monitoring operation of the shredder. In alternative embodiments, hard-wired circuitry may be used in place of or in combination with software instructions to implement the disclosure. Thus, embodiments of this disclosure are not limited to any specific combination of hardware circuitry and software. Any type of computer program product or medium may be used for providing instructions, storing data, message packets, or other machine readable information associated with the method 61. The computer readable product or medium, for example, may include non-volatile memory and other permanent storage devices that are useful, for example, for transporting information, such as data and computer instructions. In any case, the medium or product should not be limiting.

All patents and applications mentioned herein, including those in the Related Art section, are hereby incorporated herein by reference in their entirety.

While the principles of the invention have been made clear in the illustrative embodiments set forth above, it will be apparent to those skilled in the art that various modifications may be made to the structure, arrangement, proportion, elements, materials, and components used in the practice of the invention.

It will thus be seen that the objects of this invention have been fully and effectively accomplished. It will be realized, however, that the foregoing preferred specific embodiments have been shown and described for the purpose of illustrating the functional and structural principles of this invention and are subject to change without departure from such principles. Therefore, this invention includes all modifications encompassed within the spirit and scope of the following claims.

What is claimed is:

1. A shredder comprising:
 - a housing having a throat for receiving at least one article to be shredded;
 - a shredder mechanism received in the housing and including an electrically powered motor and cutter elements, the shredder mechanism enabling the at least one article to be shredded to be fed into cutter elements and the motor being operable to drive the cutter elements in a shredding direction so that the cutter elements shred the articles fed therein upon receiving electrical power via a power source;
 - a current sensor for detecting current flowing through the motor;
 - a controller coupled to the motor for controlling operation of the motor;
 - the controller also being coupled to the current sensor and configured to detect at least an inrush current supplied to the motor for each shredding event of a plurality of shredding events, and
 - the controller being configured to set a parameter of the shredder based on the detected inrush current supplied to the motor.
2. A shredder according to claim 1, wherein the controller is configured to set an overload detection threshold at or before which the motor will stall, and wherein, upon detection by the controller that a load on the motor is substantially equal to or greater than the overload detection threshold, the controller is configured to limit the electrical power to the motor, thereby preventing the motor from driving the cutter elements in the shredding direction.

3. The shredder according to claim 2, wherein the controller is configured to adjust the overload detection threshold based on the detected inrush current for each shredding event.

4. A shredder according to claim 2, wherein the threshold is set based on a fraction of the detected inrush current.

5. A shredder according to claim 1, wherein the controller is configured to set a maximum thickness threshold for shredding articles with the shredder mechanism, and wherein, upon detection by the controller that the at least one article received by the throat is substantially equal to or greater than the maximum thickness threshold, the controller is configured to limit the electrical power to the motor, thereby preventing the motor from driving the cutter elements in the shredding direction.

6. The shredder according to claim 5, wherein the controller is configured to adjust the maximum thickness threshold based on the detected inrush current for each shredding event.

7. The shredder according to claim 1, further comprising a detector for detecting the at least one article received in the throat, the detector being coupled to the controller.

8. The shredder according to claim 7, wherein the detector is a thickness detector configured to detect a thickness of the at least one article, and, wherein the controller is coupled to the thickness detector and the parameter is a maximum thickness threshold.

9. The shredder according to claim 8, wherein the controller is configured to prevent the motor from driving the cutter elements in the shredding direction based on the at least one article received by the throat being substantially equal to or greater than the maximum thickness threshold.

10. The shredder according to claim 9, wherein the controller is configured to adjust the maximum thickness threshold based on the detected inrush current for each shredding event.

11. The shredder according to claim 1, wherein the current sensor is integrated within the controller.

12. The shredder according to claim 1, wherein the current sensor is separate from the controller.

13. The shredder according to claim 1, wherein the motor is selected from the group consisting of: an AC induction motor, a DC motor, a permanent magnet motor, or a universal motor.

14. A method for monitoring operation of a shredder, the shredder comprising a housing having a throat for receiving at least one article to be shredded, a shredder mechanism received in the housing and including an electrically powered motor and cutter elements, the shredder mechanism enabling the at least one article to be shredded to be fed into cutter elements and the motor being operable to drive the cutter elements in a shredding direction so that the cutter elements shred the articles fed therein upon receiving power via a power source, a current sensor for detecting current flowing through the motor, and a controller coupled to the current sensor and coupled to the motor for controlling operation of the motor; the method comprising:

- powering the motor with electrical power via the power source;
- detecting with the controller an inrush current supplied to the motor for each shredding event of a plurality of shredding events, and
- setting with the controller a parameter of the shredder based on the determined inrush current supplied to the motor.

15. The method according to claim 14, wherein the controller sets an overload detection threshold at which the motor will stall, and further comprising:

- limiting via the controller the electrical power to the motor to prevent the motor from driving the cutter elements in

19

the shredding direction upon a load on the motor is substantially equal to or greater than the overload detection threshold.

16. The method according to claim **15**, further comprising adjusting via the controller the overload detection threshold based on the detected inrush current for each shredding event.

17. The method according to claim **14**, wherein the controller sets a maximum thickness threshold for shredding articles with the shredder mechanism, and further comprising:

limiting via the controller the electrical power to the motor to prevent the motor from driving the cutter elements in the shredding direction upon detection by the controller that the at least one article received by the throat is substantially equal to or greater than the maximum thickness threshold.

18. The method according to claim **17**, further comprising adjusting via the controller the maximum thickness threshold based on the detected inrush current for each shredding event.

20

19. The method according to claim **14**, further comprising detecting with a detector the at least one article received in the throat, the detector being coupled to the controller.

20. The method according to claim **19**, wherein the detector is a thickness detector, wherein the controller is coupled to the thickness detector and the parameter is a maximum thickness threshold, and further comprising:

detecting a thickness of the at least one article received by the throat.

21. The method according to claim **20**, wherein the controller is configured to prevent the motor from driving the cutter elements in the shredding direction based on the at least one article received by the throat being substantially equal to or greater than the maximum thickness threshold.

22. The method according to claim **21**, further comprising adjusting via the controller the maximum thickness threshold based on the detected inrush current for each shredding event.

* * * * *