



KEIHIN PE24 Carburetor Kit Instruction Manual

Item No. : 0 3 0 5 0 2 3 (Carburetor Kit)
: 0 3 0 2 0 3 1 (Inlet pipe Kit)
Compatible with : Dream50
Frame No. : AC15-1000001 ~

- Thank you for purchasing one of our products. Please strictly follow the following instructions in installing and using the kit.
- Before installing the kit, please be sure to check the contents. Should you have any questions about the kit, please contact your local motorcycle dealer.

Please note that, in some cases, the illustrations and photos may vary from the actual hardware.

Please read the following before starting the installation

We do not take any responsibility for any accident or damage whatsoever arising from the use of the kit not in conformity with the instructions in the manual.

We shall be held free from any kind of warranty whatsoever of products other than this product if the glitch takes place on the other products than this one after the installation and use of this product.

If you make modifications to any product of the kit, we shall be held free from any guarantee of the product.

You are kindly requested not to contact us about the combination of our products with other manufacturers'.

Please note that this kit is designed for exclusive use in the above-mentioned compatible model and frame numbers only and that it cannot be mounted on other models.

CAUTION

The following show the envisioned possibility of injuries to human bodies and property damage as a result of disregarding the following cautions.

- Work only when the engine and muffler are cool. (Otherwise, you will burn yourself.)
- Do the installation with right tools. (Otherwise, breakage of parts or injuries to yourself may take place.)
- Always use a torque wrench to screw bolts and nuts tight and securely to the specified torque. (Otherwise, these parts may get damaged or fall off, resulting in accidents.)
- As some products and frames have sharp edges or protruding portions, please work with your hands protected. (Otherwise, you will suffer injuries.)
- Before riding, always check every section for slack in parts like screws. If you find slack ones, screw them securely up to the specified torque. (Otherwise, improper tightening may cause parts to come off.)
- As this product has an air funnel, it collects dust in the air more easily than an air cleaner and air filter. Therefore, regular maintenance is essential. (Otherwise, the failure may cause engine damage.)
- Please refrain from driving in the rain, as much as possible. Driving in the rain may cause engine to get wet. So, be sure to perform the engine maintenance without fail. (Moisture in the engine may cause the engine to go wrong.)
- When the engine is off, do not leave the gasoline cock open for a long time. (There is a possibility of the gasoline overflowing.)

WARNING

The following show the envisioned possibility of human death or serious injuries to human bodies as a result of disregarding the following cautions.

- Those who are technically unskilled or inexperienced are required not to do the work. (Improper installation because of insufficient skill and knowledge could lead to parts breakage and subsequently to accidents.)
- Always start the engine in a well-ventilated place, and do not turn on the engine in an airtight place. (Otherwise, you will suffer from carbon monoxide poisoning.)
- Never look into the carburetor's intake pipe when the engine is running. (Flames could spurt by the spitting-back of gasoline or backfire, which may cause burns, loss of sight and injury.)
- Before riding, always check every section for slack in parts and oil leak. If you find slack in screws and other parts, screw them securely to the specified torque with a torque wrench. Driving with loose parts may lead to parts coming off or to accidents. (And if you continue driving with gasoline leaking, there is a possibility of vehicle fire.)
- When you notice something abnormal with your motorcycle while riding, stop riding immediately and park your motorcycle in a safe place. (Otherwise, the abnormality could lead to accidents.)
- Before doing work, make sure your bike is secure on level ground for safety's sake. (Otherwise, your motorcycle could overturn and injure you while you are working.)
- Check or carry out maintenance of your motorcycle correctly according to the procedures in the instruction manual or service manual. (Improper checking or maintenance could lead to accidents.)
- If you find damaged parts when checking and performing maintenance of your motorcycle, do not use these parts any longer, and replace them with new ones. (The continued use of these damaged parts as they are could lead to an accident.)
- As gasoline is highly flammable, never place it close to fire. Make sure that nothing flammable is near the gasoline. Since vaporized accumulation of gasoline is at high risk of explosion, work in a well-ventilated place. (Otherwise, it may cause a fire.)

Please be informed that, mainly because of improvement in performance, design changes, and cost increase, the product specifications and prices are subject to change without prior notice.

This manual should be retained for future reference.

~ Kit Contents ~

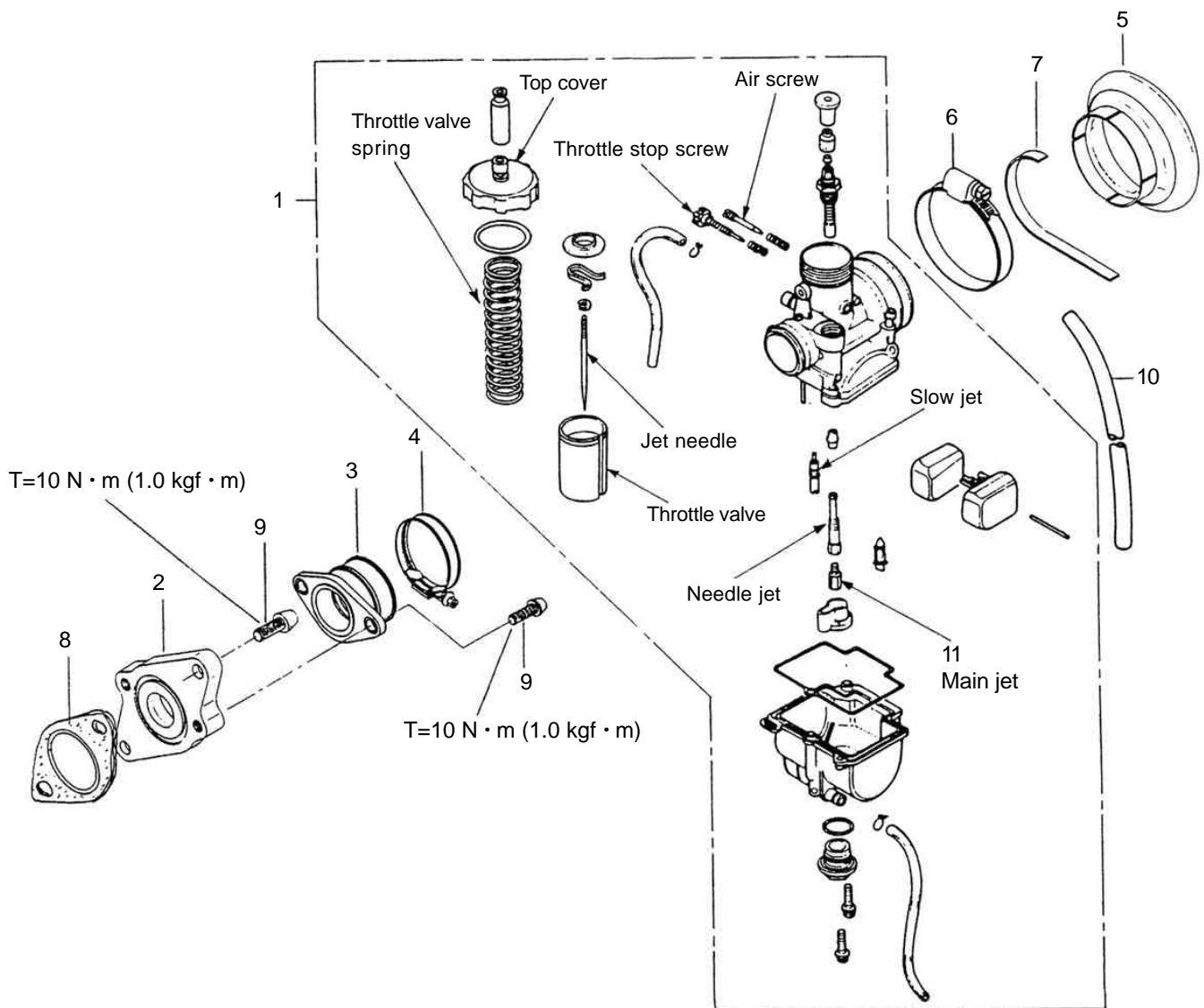

No.	Part Name	Qty
1	Carburetor assembly	1
2	Inlet pipe	1
3	Insulator	1
4	Insulator band	1
5	Air funnel	1
6	Funnel band	1
7	Funnel gasket	1
8	Gasket	1
9	Socket cap screw, 6x15	4
10	Fuel tube	1
11	Main jet, #105	1
	Insulation lock, 100 mm	2
Tool	Hex wrench, 5 mm	1

marks indicate the contents of a Inlet pipu kit.

Factory preset mode of the carburetor

Main jet	#108
Slow jet	#48
Jet needle	36S
Clip position	3rd groove from top
Throttle valve	1SC
Cut-away	#3.0
Air screw opening	1 - 1/2

Engine Specification

Engine	STD
Camshaft	STD
Ignition System	Hyper CDI
Muffler	Megaphone muffler

~ Installation Procedures ~

Check the kit contents.

Prepare tools suitable for the work.

⚠ Warning : Make sure that your motorcycle is secure on level ground.

⚠ Caution : Check that the engine and muffler are cold.

⚠ Warning : Gasoline is so inflammable that never use fire in the work place. And beware of fireworks as well as naked lights which may trigger electric sparks.

Removal

- 1 . Turn off the fuel cock.

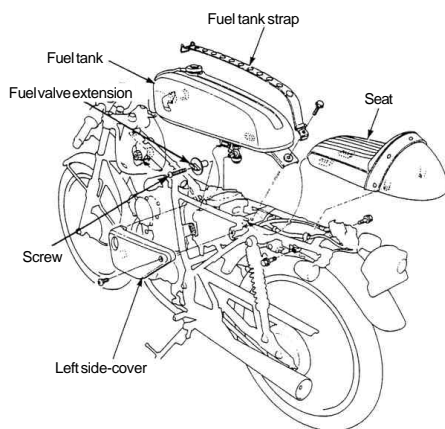

- 2 . Unfasten two flange bolts on the seat to remove the seat.
- 3 . Unfasten a screw on the left side-cover to remove the cover.
- 4 . Unfasten a screw on the fuel valve extension to remove the extension.
- 5 . Disconnect the fuel tube from the fuel cock.
- 6 . Unfasten the fuel-tank mounting bolt, detach the fuel tank strap, and then remove the fuel tank by holding its back up and pulling it backward.

After demounting the fuel tank, place the tank on a stable solid object like a block to prevent the damage to the fuel cock, falling of the tank, and gasoline leaks.

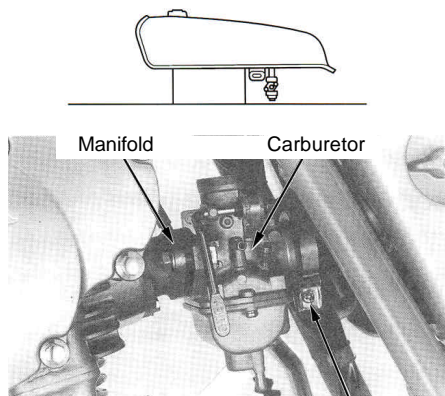

Connecting tube band screw

- 7 . Loosen the carburetor top to remove it.
- 8 . Compressing the throttle valve spring, detach the throttle cable from the throttle valve, and then the carburetor top from the throttle cable.
- 9 . Place a gasoline container under the carburetor float chamber. Loosen the drain screw on the carburetor to drain gasoline in the carburetor into the container.

⚠ Warning: No Fire

- 10 . Loosen a screw on the air-screw connecting tube band and unfasten two M6 manifold-mounting bolts (on the engine side) to remove the carburetor.

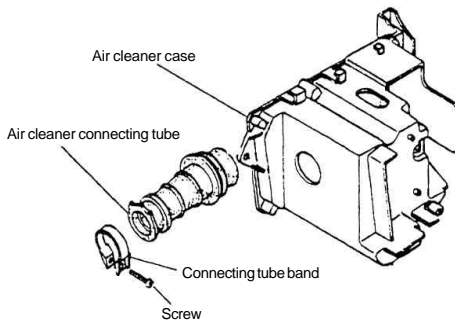

- 11 . Remove the air-cleaner connecting tube on the air-cleaner case.

Installation

- 1 . Fasten the insulator (No.3) tightly to the inlet pipe (No.2) of the kit with two socket cap screws (No.9).

⚠ Caution: Be sure to tighten to the specified torque.

Torque: 10 N · m (1.0 kgf · m)

- 2 . Fasten the gasket (No.8) and the inlet pipe (No.2) tightly to the cylinder head with two socket cap screws (No.9).

⚠ Caution: Be sure to tighten to the specified torque.

Torque: 10 N · m (1.0 kgf · m)

- 3 . Remove a carburetor top from the carburetor (No.1) of the kit, and attach the carburetor top to the throttle cable.
- 4 . Wind the funnel gasket (No.7) around the carburetor (No.1). Attach the air funnel (No. 5) and fix it with the funnel band (No. 6).
- 5 . Put the carburetor (No.1) into the insulator (No.3), which please fix with the insulator band (No.4).
- 6 . Attach the throttle valve spring to the throttle cable on the carburetor top. And compressing the throttle valve spring, attach the throttle cable end to the throttle valve.
- 7 . Aligning the notch on the throttle valve with the throttle stop screw, and attach the throttle valve to the carburetor body. And fasten the carburetor top.

- 8 . Snap the throttle a few times to make sure that the throttle moves smoothly without sticking and that the throttle valve is fully open.
- 9 . Joining together the hook on the fuel tank and fuel-tank mounting rubber on the frame, mount the fuel tank.

In order not to damage the fuel cock at the bottom of the fuel tank, raise the back of the fuel tank off the ground.

- 10 . Hang the fuel-tank strap on the hook of the frame, and fix it firmly with a mounting bolt.

⚠ Caution: Be sure to tighten to the specified torque.

Torque: 10 N · m (1.0 kgf · m)

- 11 . Insert the fuel tube into the fuel cock on the fuel tank. And cut the fuel tube to the proper length, being careful not to break it.

Connect the fuel tube to the carburetor, and fix it with the insulation lock of the kit.

- 12 . Attach the fuel-valve extension to the fuel valve, and open the fuel cock to check every place for the oil leak.

After confirming that there is no oil leak, tighten the screw, and fix the fuel-valve extension.

- 13 . Attach the left side-cover.

- 14 . Install the seat, joining together the hooks both on the seat and frame, and fasten the seat tightly with two flange bolts.

⚠ Caution: Be sure to tighten to the specified torque.

Torque: 12 N · m (1.2 kgf · m)

- 15 . Pull the choke lever to start the engine. Gradually push the lever back and warm up the engine till the revolution becomes smooth, and finally push the lever back to its original location.

- 16 . Do the setting with the utmost care in a safe place.

SPECIAL PARTS TAKEGAWA Co.,Ltd.

3-5-16 Nishikiorihigashi Tondabayashi
Osaka Japan

TEL : 81-721-25-1357 FAX : 81-721-24-5059

URL : <http://www.takegawa.co.jp>

How to Set the Carburetor

- When the carburetor does not match the engine and the engine fails, the engine failures are caused by either too dense or too lean air-fuel mixture.
- The engine failure symptoms for the engine are as follows:

When the air-fuel mixture is too dense:	When the air-fuel mixture is too lean:
<ul style="list-style-type: none"> • The explosion sound with a dull thud continues intermittently. • The engine malfunctions further if you use the choke. • The engine malfunctions when you warm it up. • The engine works well if the cleaner is detached. • The motorcycle belches dense (or, black) exhaust gas. • The plug smolders, getting blackened. 	<ul style="list-style-type: none"> • The engine overheats somewhat. • The engine starts working well if you use the choke. • The engine does not accelerate well. (No smooth acceleration) • Revolutions change, generating weak power. • The plug burns white.

Set the carburetor only after warming up the engine, and then test-drive. And use a plug with the right heat value. Do the setting in the following manner, studying at what throttle opening position the engine starts failing.

Jet needle (Throttle position at 1/4 - 3/4)

Whether or not the engine revolution is in proportion to the throttle operation

- When the acceleration is not smooth or even, make the air-fuel mixture dense.
- Make the air-fuel mixture lean when the engine revolution goes up heavily and belches black gas.

The mixture ratio at this throttle position can be adjusted by the location of E-ring in the grooves. The air-fuel mixture becomes dense as the location of the E-ring moves down from the 1st to the 5th groove.

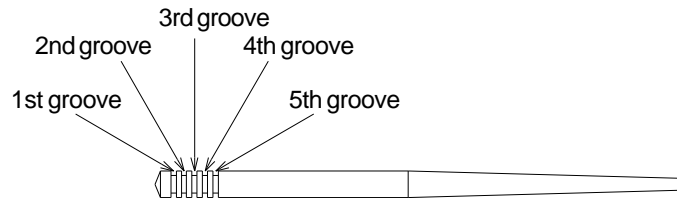

Main jet (The throttle position at 3/4 - 4/4)

The air-fuel mixture ratio at this throttle position can be adjusted by changing the number of the main jet. The larger the main jet numbers, the denser the mixture ratio becomes.

In view of the engine and muffler specifications, select the most appropriate main jet to get the highest revolutions.

Pilot jet (First of all, please adjust the air screw.)

- In case you have given more than three turns to the air screw to tighten it, use a pilot jet with a small number.
 - If you have tighten the air screw (clockwise) to the full, use a pilot jet with a larger number.
- Check whether you have made a right choice of the pilot jet by seeing if the engine starts up revolving smoothly from the idling to running at slow speed.
- When the engine revolves up unevenly, the pilot jet number is too small. (At idle)
 - When the motorcycle belches black exhaust gas and produces heavy exhaust sound, the pilot jet number is too big. (At idle)
 - After replacing the pilot jet, you need to readjust the airscrew.

Air screw

The air screw adjusts the air mass flow at the time of engine's revolving at slow speed. (At idling)

- Give the air screw a right turn The air-fuel mixture gets dense.
- Give the air screw a left turn The air-fuel mixture gets lean.

Loosen the tightened air screw back to the 1.5-turn position. And then from this position, give to the airscrew a right or left turn of 1/4 to 1/2 till the engine revolves at the highest speed.

Loosen the idle stop screw till you get the steady idling revolutions. And once again adjust the position of the airscrew to get the highest revolutions.

On how the barometric pressure, temperatures and humidity affect the setting:

- At highlands or at high altitudes, the barometric pressure and air density go down and the air gets into the carburetor in less amounts. This makes the air-fuel mixture dense which was adjusted at low altitudes.
- Under the weather conditions with very low temperatures, the air density increases, which makes the air-fuel mixture lean.
- Under the rainy and humid weather conditions, the air density decreases, which makes the air-fuel mixture dense.

Please be informed that, mainly because of improvement in performance, design changes, and cost increase, the product specifications and prices are subject to change without prior notice.

This manual should be retained for future reference.

SPECIAL PARTS TAKEGAWA Co.,Ltd.

3-5-16 Nishikiorihigashi Tondabayashi Osaka Japan TEL: 81-721-25-1357 FAX: 81-721-24-5059 URL: <http://www.takegawa.co.jp>