

DP-74.1, DP-74.1-GRI, DP-90.1 & DP-90.1-GRI DIAPHRAGM PUMP Parts & Instruction Manual

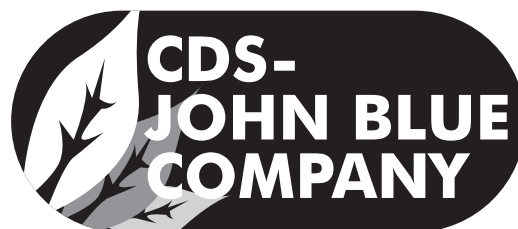
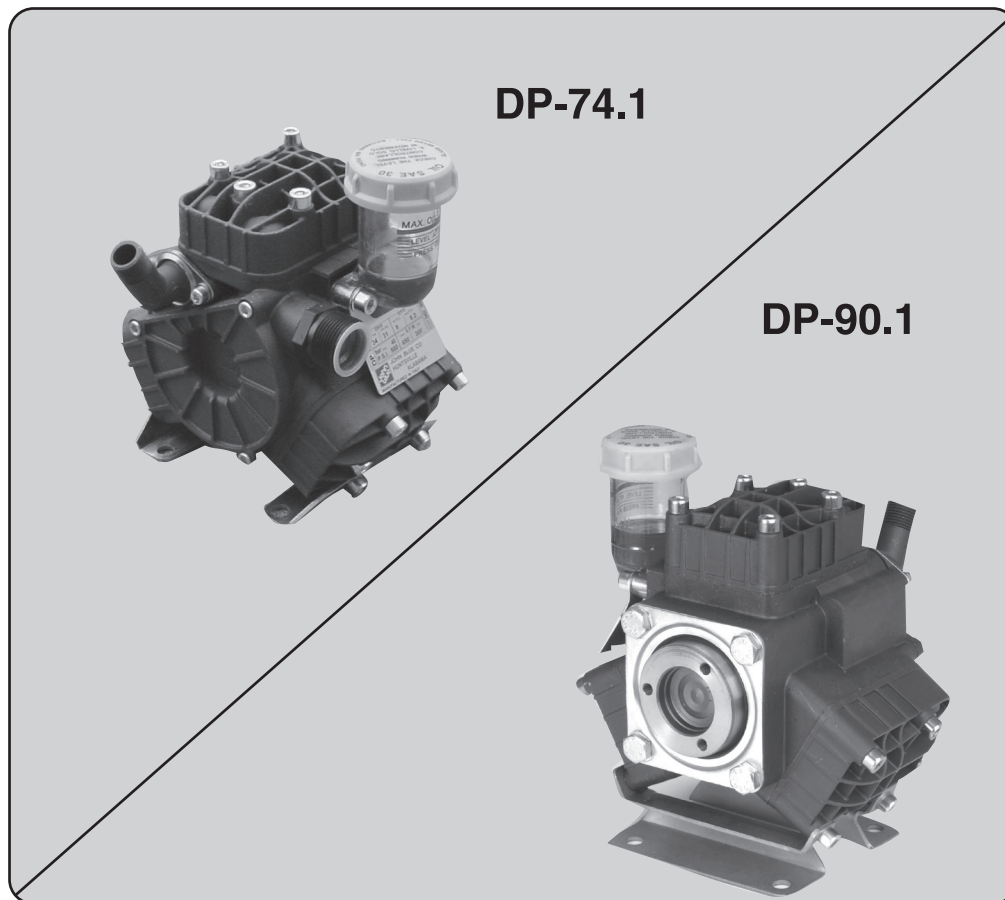

CDS-JOHN BLUE COMPANY

DIVISION OF ADVANCED SYSTEMS TECHNOLOGY, INC.

165 Electronics Blvd., Huntsville, AL 35824

Telephone: (256) 721-9090 • FAX (256) 721-9091 • Call Toll Free: 1-800-253-2583

SAFETY PRECAUTIONS

- Equipment should be operated only by trained, responsible people.
- A careful operator is the best insurance against an accident.
- Fill system with WATER first and check output.
- Check all valves, fittings, hose clamps, etc. for tightness and soundness before admitting fluid to system.
- Replace hoses when worn, cracked or if leaking.

WARNING: USE OF THIS PRODUCT FOR ANY PURPOSES OTHER THAN ITS ORIGINAL INTENT, ABUSE OF THE PRODUCT, AND/OR MODIFICATION TO THE ORIGINAL PRODUCT IS STRICTLY PROHIBITED BY CDS-JOHN BLUE COMPANY. CDS-JOHN BLUE COMPANY RESERVES THE RIGHT TO DENY WARRANTY OR LIABILITY CLAIMS IN ANY/ALL SITUATIONS INVOLVING MISUSE, ABUSE OR MODIFICATION.

THE ORIGINAL INTENT OF THIS PRODUCT DOES NOT INCLUDE USE WHERE THE MAXIMUM ALLOWED SPEED, PRESSURE, OR TEMPERATURE IS EXCEEDED, AND IT DOES NOT INCLUDE APPLICATION UTILIZING FLUIDS THAT ARE NOT COMPATIBLE WITH THE PRODUCT'S COMPONENT MATERIALS. DO NOT USE THIS PRODUCT WITH FLAMMABLE OR COMBUSTIBLE FLUIDS SUCH AS GASOLINE, KEROSENE, DIESEL, ETC....., AND DO NOT USE IN EXPLOSIVE ATMOSPHERES. FAILURE TO FOLLOW THIS NOTICE MAY RESULT IN SERIOUS INJURY AND/OR PROPERTY DAMAGE AND WILL VOID THE PRODUCT WARRANTY. IF IN DOUBT ABOUT YOUR APPLICATION, CONTACT YOUR STOCKING DEALER OR THE CDS-JOHN BLUE TECHNICAL STAFF AT 1-800-253-2583.

BE CAREFUL! REMEMBER, SAFETY IS NO ACCIDENT

TO THE OWNER

This manual has been prepared and illustrated to assist you in the maintenance of your CDS-JOHN BLUE PUMP.

Enter your serial number and date of purchase in the space provided below for future reference in service information or for ordering parts.

Because our engineering department is constantly improving products, we reserve the right to make design and specification changes without notice.

Serial No.

Purchase Date

INSTALLATION AND GENERAL SAFETY INFORMATION

- 1) Always mount pump with oil sight tube in upright position.
- 2) Proper selection of type and size hose is vital to good performance:
 - Diameter of inlet hose should be at least that of the pump inlet hose barb or greater.
 - Use only hoses rated for maximum pressure rating of the pump.
- 3) Use of a pressure relief device on the discharge side of pump is required to prevent damage from pressure build up if the discharge is closed or blocked while the power source is still running.
- 4) Install one or more suitably sized strainers (at least one and a half times flowrate) on the pump supply. The filtering service should be dimensioned as required.

INSTALLATION DIAGRAMS OF THE PUMP

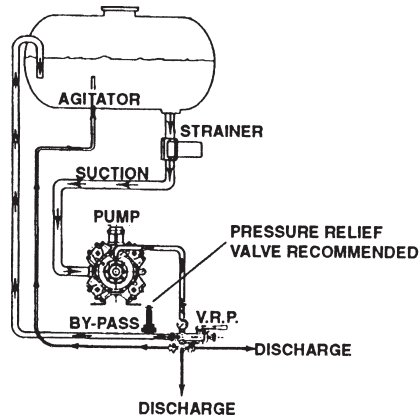

- 5) Do not operate pump above 145°F (62°C) liquid temperature.
- 6) Provide adequate protection by placing guards around the moving parts such as the shaft and pulleys.
- 7) Attach the pump to a strong base plate and anchor it with bolts sufficiently strong to hold it in place.
- 8) Periodically inspect the pump and the system components. Perform routine maintenance as required (see Maintenance section).
- 9) Wiring an electrically driven pump, follow all electrical and safety regulations.
- 10) If the pump is driven by a gasoline engine, make sure that the area is well ventilated.

Checks to make before using the pump

-With the pump not running, check to make sure that the oil level is correct. Repeat with the pump running.

OIL LEVEL USED ON 2 DIAPHRAGM PUMPS

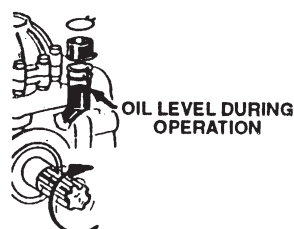
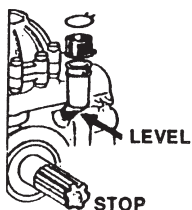

OIL LEVEL USED ON 2 DIAPHRAGM PUMPS

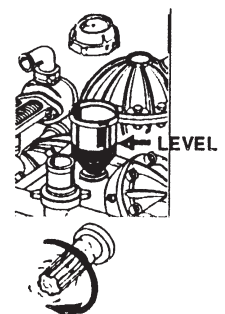

- Check to make sure that the inlet, discharge and by-pass hoses have the correct diameter, i.e. never smaller than the union on the pump. The hoses should not be crimped and the hose clamps should be sized for hose diameter.
- Prevent any hose restrictions and be sure connections are tight to prevent air entering, since these conditions will compromise pump performance.
- If pumping from a tank, check to make sure that the control unit by-pass line is not too close to the inlet line. Make sure that it does not create turbulence inside the tank.
- Check air pressure in the pulsation damper. It should be kept within specs given in the Chart on the Service Manual.
- The pressure regulator lever should be turned downward. Whenever the by-pass jet is used, the pressure adjustment lever must be turned in the down position so that the pressure is zero.
- Check to make sure the strainer is clean. Be sure the cartridge is reinstalled and tightened to assure no suction leak.
- Check for leaks.

Suction Head

Do not use suction head for filling the tank. Avoid suction head higher than 10 feet. In this case, some troubles may occur in the pump parts.

Operation Instructions

- Start pump and let run for approximately one minute at zero pressure to facilitate priming. Once primed, the pump is ready and can be set to run at the desired pressure by moving the lever downwards and turning the adjustment knob clockwise.
- Operating pump above recommended rpm will not improve performance but rather may damage the pump. Operation at rpm higher than specifications voids all warranties.
- Working pressure should be selected with the discharge line closed and all liquid in by-pass.
- While the pump is running, check the oil level in sight glass. This **acts as an emergency indicator to signal malfunction**, e.g. if the diaphragm breaks, the oil will become white. Stop the pump immediately.
- Do not rotate the shaft for long periods without liquid in the cylinders or in the suction line.
- If the pump is driven by a PTO shaft and sprayer makes a sharp turn, disconnect the tractor PTO to prevent damage to the shaft supports and to the crankcase.
- If oil volume increases due to high operating temperature and the oil reaches the level of the plug, stop the pump to prevent damage from internal overpressure.

After Use

After use, in order to prevent damage, flush pump and let operate for a few minutes at working pressure with a solution that will neutralize the liquid last pumped (refer to that manufacturer's instructions). Afterward empty the pump, so that the pressure drops to zero ("0"), and then let the pump run without liquids for two minutes.

To protect pump from freezing, flush pump per instructions above (after use) and then flush with straight RV-antifreeze. Empty the pump per the instructions above.

Ordinary Maintenance

Change oil every 500 hours as follows:

- Remove cap from oil sight tube and drain plug.
- Turn pump upside down and rotate the shaft by hand until oil stops flowing out.
- It is recommended to make an inside washing with gasoline or diesel oil.
- Put the drain plug back and pour oil into sight tube while turning the pump shaft. Be sure oil is at the indicated level and care not to exceed it.
- Start the pump at pressure "0" for a few minutes to allow the correct lubrication of inside parts, then check oil level.

Coupling to Agricultural Machinery

- 1) Check that the PTO of the machine does not exceed the max rpm shown on the pump plate.
- 2) If the PTO is synchronized with the motor speed, consult the service manual to get gear number and rpm corresponding to the max pump rotation speed.
- 3) When the rpm of the PTO is higher than the max speed, use the suggested reduction gear.
- 4) Disconnect the PTO when moving with pump out of service; if that is impossible, then disengagement should be provided.
- 5) Disconnect the PTO when changing direction.

Coupling to electric motors and gasoline engines

- 1) For direct coupling always use the suggested reduction gear.
- 2) For coupling with pulley, check alignment of the two pulleys.

$$\text{Maximum Transmission Ratio: } \frac{\text{Motor RPM}}{\text{Pump RPM}} = K$$

After determining K, you can establish the motor or pump pulley diam.:

$$\text{Motor Pulley Pitch Diam.: } m.p.\phi = \frac{\text{Pump Pulley Pitch Diameter}}{K} = K$$

$$\text{Pump Pulley Pitch Diam. - } p.o.\phi = \text{Motor Pulley Pitch } \phi \times K$$

MAINTENANCE FOR DIAPHRAGM PUMPS

Routine maintenance on the pump includes changing the diaphragms, oil, valve assembly, o-rings, all of which are normal wear parts.

1) Valve assembly and O-Rings Replacement

Occasionally debris can cause the valves to not seat properly or damage o-rings. To check for this problem please follow these steps:

- Remove the valve cover (consult the exploded drawing of the pump), remove the valves, check for debris and wear as well as o-rings.
- Replace necessary parts and reassemble.
- Repeat for all valves. Consult the parts list for the valve kit or o-ring kit part numbers.

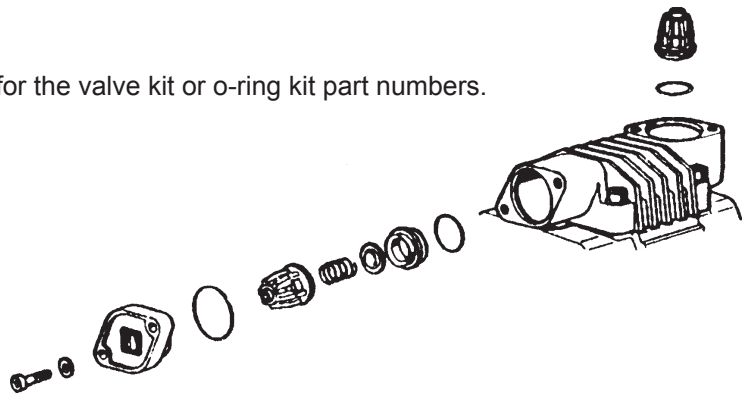

2) Diaphragm Replacement

- Drain the oil from the pump by removing cap under the crankcase. Rotate the shaft to remove excess oil.
- Remove the pump heads one by one.
- Use a hex wrench to remove the diaphragm locknut: remove the nut, retaining washer, diaphragm and support washer.
- If you removed the piston sleeves, replace them one at a time in their previous position (best mark them when removing).
- Insert the new diaphragm on the piston and install it with its nut. Use these tightening torques.

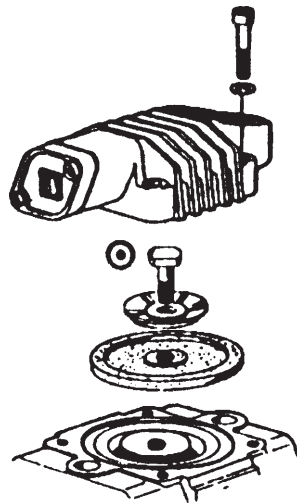

- 10 mm.=36 ft.-lbs.
- 12 mm.=50 ft.-lbs.
- 12 mm.=72 ft.-lbs.

The diaphragms should be replaced with the piston at its bottom DP and the edges inserted perfectly into the groove all the way around.

- Replace the heads and attach them with their bolts.
- Refill pump with oil through the glass and rotate the shaft to distribute oil and fill to proper level. Repeat all the checks described above in the section “Checks to make before using the pump.”
- Check oil level with the pump running with no pressure until all air bubbles have been vented.
- When the air has been bled off, close the cap on the oil sight tube.
- After the first inspection of the oil level as above, check once more the oil level with the pump running with pressure.

3) Oil Change

Normally the oil is changed whenever the diaphragm is changed. Depending on work conditions, oil should be changed every 500 hours.

The oil change procedure is described in number 2 above.

☆ **FOR TROUBLESHOOTING CHART, SEE BACK COVER** ☆

DP-74.1 And DP-74.1-GRI PUMP DIMENSIONS

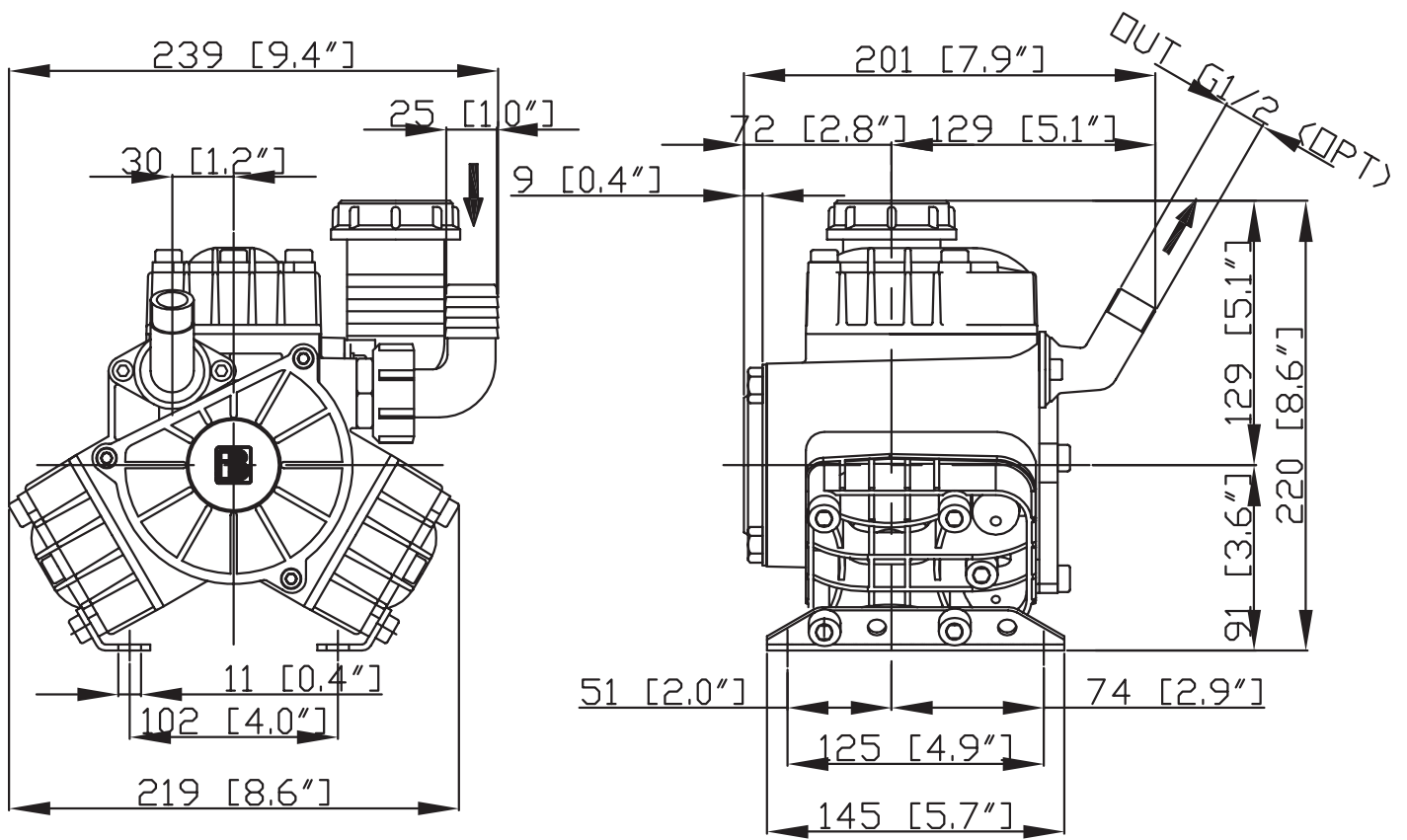

DP-74.1

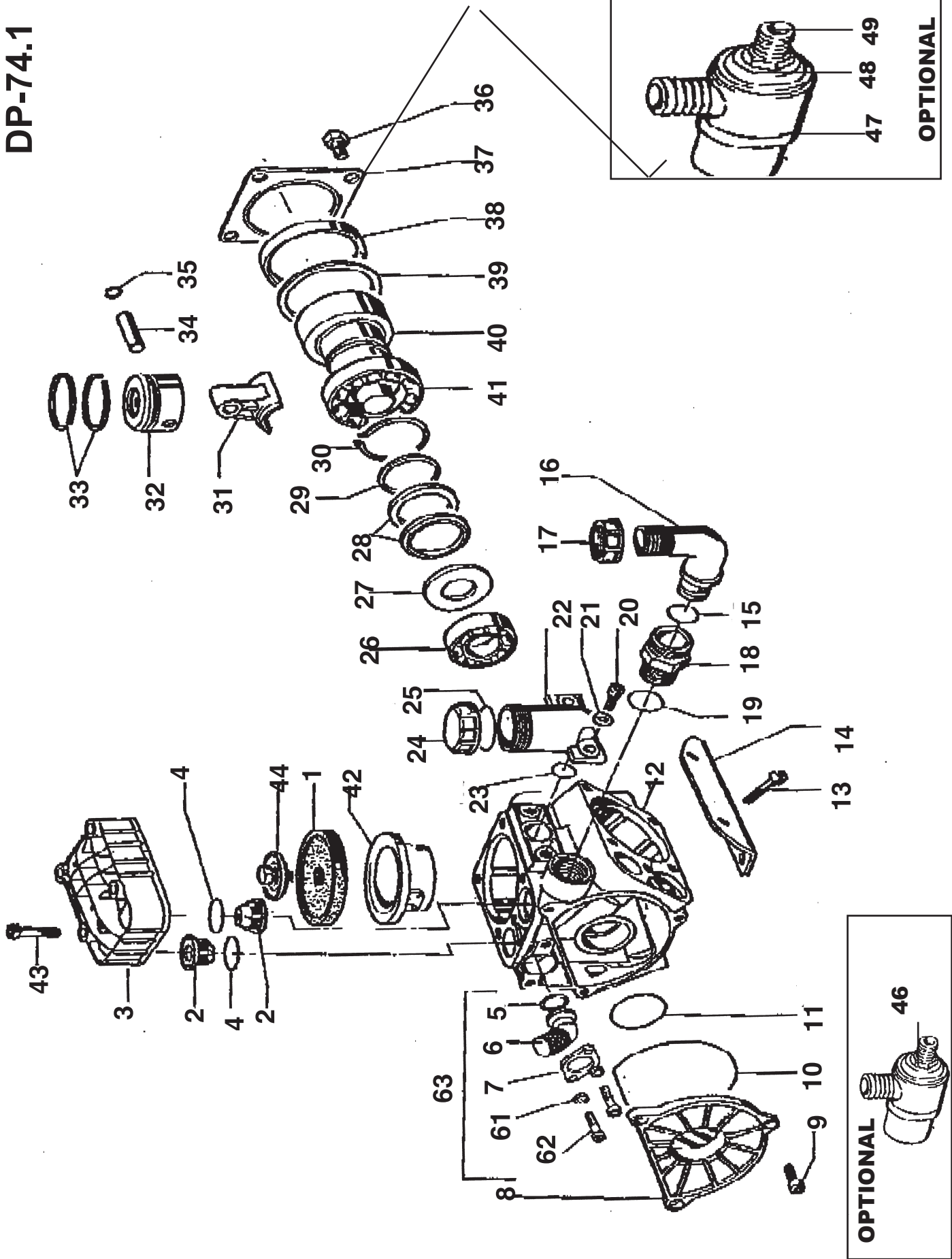

DP-74.1 & DP-74.1-GRI

POS	PART NO.	DESCRIPTION	QTY	POS	PART NO.	DESCRIPTION	QTY
1	DP-03004031	PISTON DIAPHRAGM	3	27	DP-03001161	SPACER	1
1	DP-03004000	DESMOPAN PISTON DIAPHRAGM	3	28	DP-94004776	CONROD RING	2
1	DP-03004036	HPS PISTON DIAPHRAGM	3	29	DP-03001261	SPACER	1
■ 2	DP-03982197	VALVE ASSY.	6	30	DP-80133100	SHAFT RING D.45	1
3	DP-03020209	HEAD	3	31	DP-03000509	CONROD	3
■*4	DP-03002936	VALVE SEAL	6	32	DP-03000609	PISTON	3
5	DP-80321800	O-RING 3.0X22	1	33	DP-81850250	PISTON RING	6
6	DP-31151509	OUTLET FLANGE G.1/2	1	34	DP-85200600	PISTON PIN	3
7	DP-31151761	FLANGE	1	35	DP-80000300	RING DIA. 10	6
8	DP-03000309	SUCTION COVER	1	36	DP-86318500	SCREW M10X16	4
9	DP-86213100	SCREW M6X18	3	37	DP-17001361	COVER	1
*10	DP-80321066	O-RING 2, 62X101,27	1	*38	DP-80226410	OIL SEAL	1
*11	DP-80320830	O-RING 2, 62X36,14	1	39	DP-03001561	SPACER	1
12	DP-03000109	CRANKCASE	1	40	DP-03001726	CRANKSHAFT "VF" VERSION	1
13	DP-86290000	SCREW M8X55	4	40	DP-03003826	CRANKSHAFT "RT2" VERSION	1
14	DP-03001461	MOUNTING RAIL	2	41	DP-81293300	BALL BEARING DIA. 45X75X16	1
15	DP-80320000	O-Ring 2,62X22,22	1	42	DP-03000701	PISTON SLEEVE VERS. "VF" & "VC"	3
16	DP-84054200	90 DEG. ELBOW CONNECTOR	1	42	DP-03003601	PISTON SLEEVE VERS. "RT2"	3
17	DP-82004900	WING NUT M34	1	43	DP-86289300	SCREW M8X50	11
18	DP-83506210	NIPPLES G.3/4-M34	1	44	DP-03002197	KIT DIAPHRAGM WASHER/SCREW	3
19	DP-03001631	VALVE SEAL	1	46	DP-24304097	SAFETY VALVE 40BAR (OPT)	1
20	DP-86273000	SCREW M8X30	2	47	DP-31148232	PLAIN SAFETY CONE (OPT)	2
21	DP-84368500	WASHER DIA. 8,4X15X1,5	2	48	DP-84381000	WASHER (OPT)	4
22	DP-23000832	OIL FILLER	1	49	DP-86321200	SCREW M10X20 (OPT)	4
23	DP-80318000	O-RING 2,62X15,08	1	61	DP-84358500	WASHER	2
24	DP-85275000	OIL FILLER CAP	1	62	DP-86210800	SCREW M6X16	2
25	DP-82412000	GASKET DIA. 45X9X1.5	1	63	DP-31891697	KIT	1
26	DP-81264600	BALL BEARING DIA. 20X52X15	1				

* PUMP KIT ORDER DP-03987497

■ VALVE KIT ORDER DP-03987597

DP-74.1-GRI

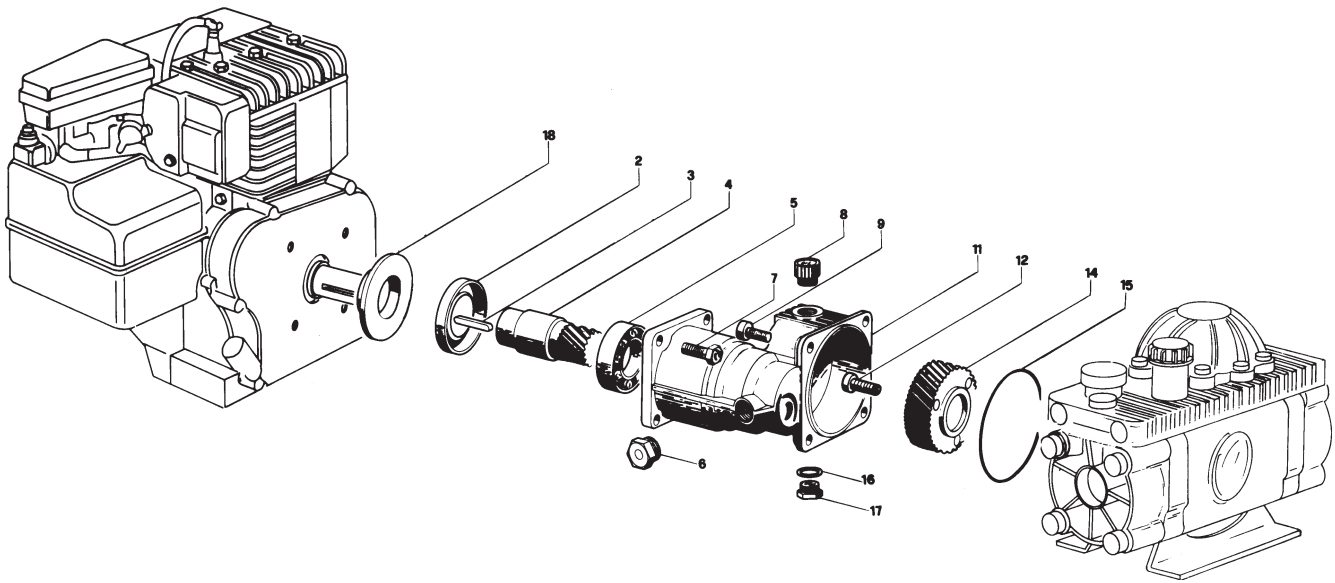

PARTS LIST FOR DP-74.1-GRI

ITEM	PART NUMBER	DESCRIPTION	QTY.
2	DP-80212650	O-RING 30X60X10	1
3	DP-80643600	KEY	1
4	DP-31079542	PINION GEAR	1
5	DP-81264600	BALL BEARING	1
6	PP-85351100	OIL SIGHT GLASS	1
7	DP-86256600	SCREW 5/16	4
8	DP-85351100	FILLER PLUG	1
9	DP-86321200	SCREW M10X20	4
11	DP-31191409	GEAR BOX	1
12	DP-86256900	SELF LOCKING SCREW	3
14	DP-31072942	GEAR	1
15	DP-80308090	O-RING 1,78X82, 27	1
16	DP-82414100	GASKET	1
17	DP-85262953	PLUG	1
18	DP-31128509	CENTERING FLANGE ENGINE/GEAR BOX	1

DP-90.1 And DP-90.1-GRI

PUMP DIMENSIONS

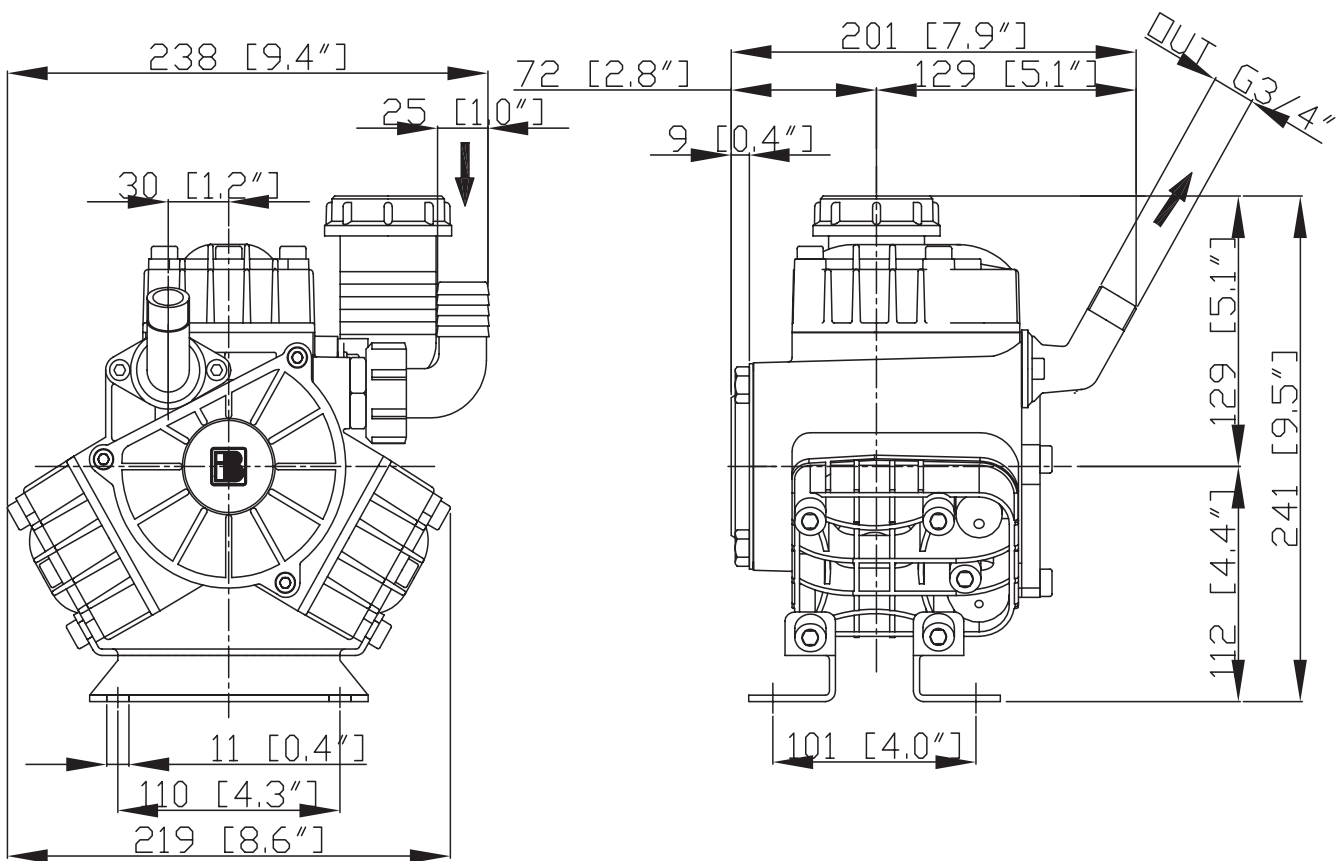

DP-90.1

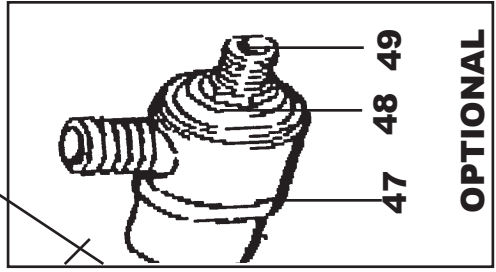
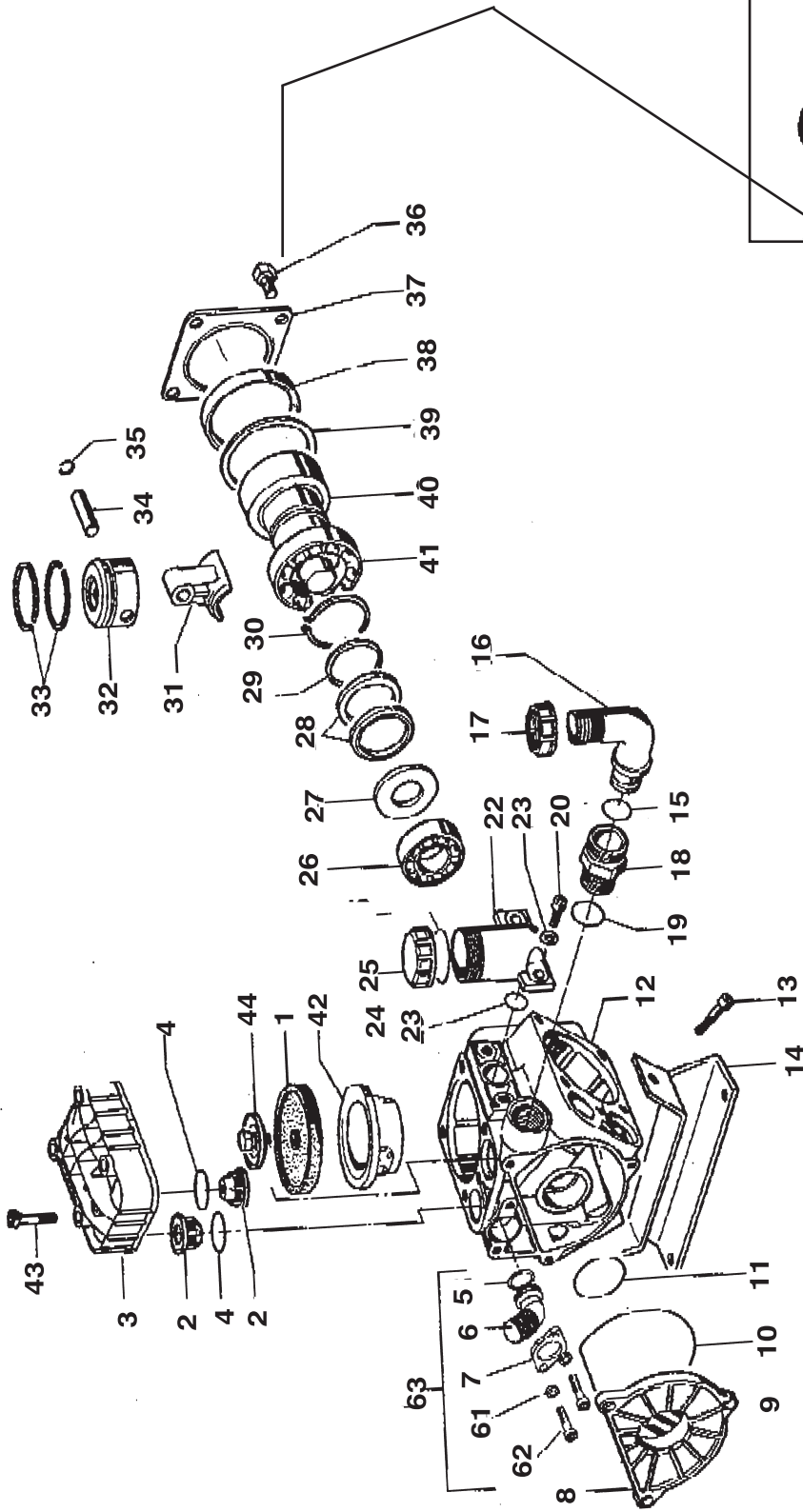

OPTIONAL

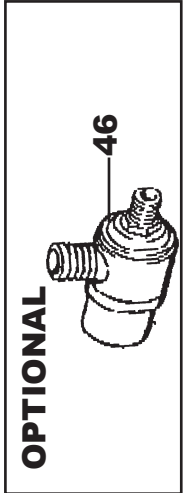

OPTIONAL

DP-90.1 & DP-90.1-GRI

POS	PART NO.	DESCRIPTION	QTY	POS	PART NO.	DESCRIPTION	QTY
1	DP-03004031	PISTON DIAPHRAGM	3	26	DP-81264600	BALL BEARING	1
1	DP-03004000	DESMOPAN PISTON DIAPHRAGM	3	27	DP-03001161	SPACER	1
1	DP-03004036	HPS PISTON DIAPHRAGM	3	28	DP-94004776	CONROD RING	2
■ 2	DP-03982197	VALVE ASSY.	6	29	DP-03001261	SPACER	1
3	DP-03020209	HEAD	3	30	DP-80133100	SHAFT RING	1
■*4	DP-03002936	VALVE SEAL	6	31	DP-03000509	CONNECTING ROD	3
5	DP-80321800	O-RING 3,0X22	1	32	DP-03000609	PISTON	3
6	DP-31151509	OUTLET FLANGE G.1/2	1	33	DP-81850250	PISTON RING	6
7	DP-31151761	FLANGE	1	34	DP-85200600	PISTON PIN	3
8	DP-03000309	SUCTION COVER	1	35	DP-80000300	RING	6
9	DP-86213100	SCREW M6X18	3	36	DP-86318500	SCREW M10X16	4
*10	DP-80321066	O-RING	1	37	DP-17001361	COVER	1
*11	DP-80320830	O-RING	1	*38	DP-80226410	OIL SEAL	1
12	DP-03000109	CRANKCASE	1	39	DP-03001561	SPACER	1
13	DP-86290000	SCREW V8X55	4	40	DP-03001826	CRANKSHAFT "VF" VERSION	1
14	DP-03003361	MOUNTING RAIL	2	41	DP-81293300	BALL BEARING	1
15	DP-80320000	O-RING	1	42	DP-03000801	PISTON SLEEVE	3
16	DP-84054200	90 DEG. ELBOW CONNECTOR	1	43	DP-86289300	SCREW M8X50	11
17	DP-82004900	WING NUT M34	1	44	DP-03002197	DIAPHRAGM WASHER/SCREW KIT	3
18	DP-83506210	NIPPLES	1	46	DP-24304097	SAFETY VALVE (OPT)	1
19	DP-03001631	VALVE SEAL	1	47	DP-31148232	PLAIN SAFETY CONE (OPT)	1
20	DP-86273000	SCREW M8X30	2	48	DP-84381000	WASHER (OPT)	4
21	DP-84368500	WASHER	2	49	DP-86321200	SCREW (OPT)	4
22	DP-23000832	OIL FILLER	1	61	DP-84358500	WASHER	2
23	DP-80318000	O-RING	1	62	DP-86210800	SCREW M6X16	2
24	DP-85275000	OIL FILLER CAP	1	63	DP-31891697	KIT	1
25	DP-82412000	GASKET	1				

* PUMP KIT ORDER DP-03987497

■ VALVE KIT ORDER DP-03987597

DP-90.1-GRI

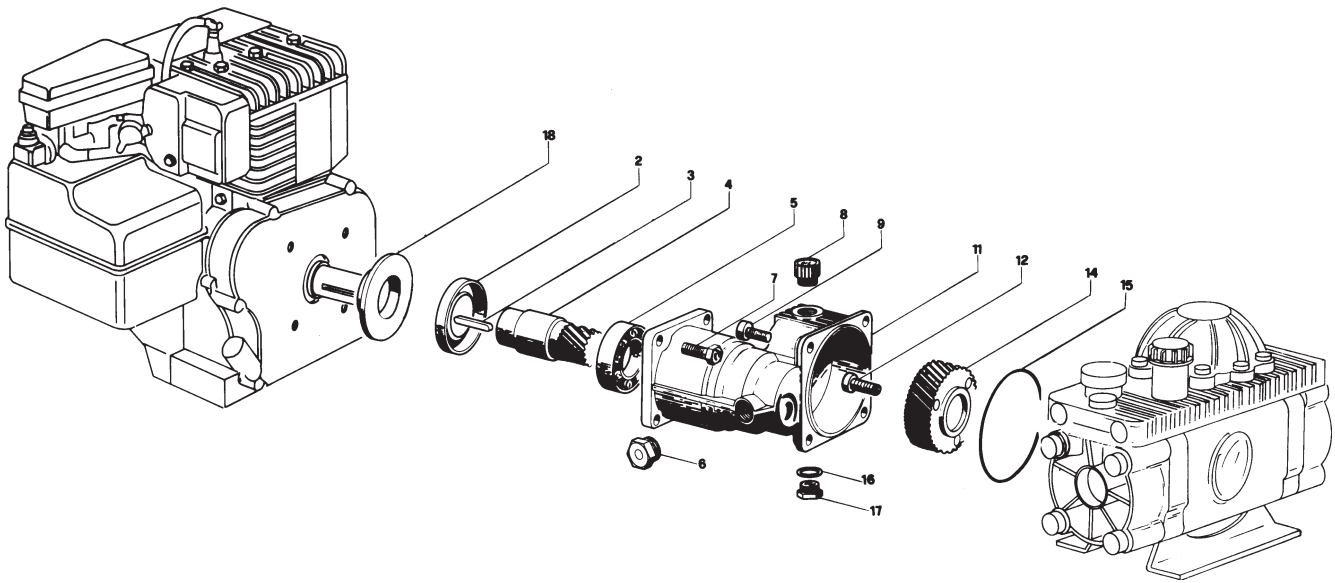

PARTS LIST FOR DP-90.1-GRI

ITEM	PART NUMBER	DESCRIPTION	QTY.
2	DP-80212650	O-RING 30X60X10	1
3	DP-80643600	KEY	1
4	DP-31079542	PINION GEAR	1
5	DP-81261600	BALL BEARING	1
6	PP-85351100	OIL SIGHT GLASS	1
7	DP-86256600	SCREW 5/16	4
8	DP-85351100	FILLER PLUG	1
9	DP-86321200	SCREW M10X20	4
11	DP-31191409	GEAR BOX	1
12	DP-86256900	SELF LOCKING SCREW	3
14	DP-31072942	GEAR	1
15	DP-80308090	O-RING 1,78X82, 27	1
16	DP-82414100	GASKET	1
17	DP-85262953	PLUG	1
18	DP-31128509	CENTERING FLANGE ENGINE/GEAR BOX	1

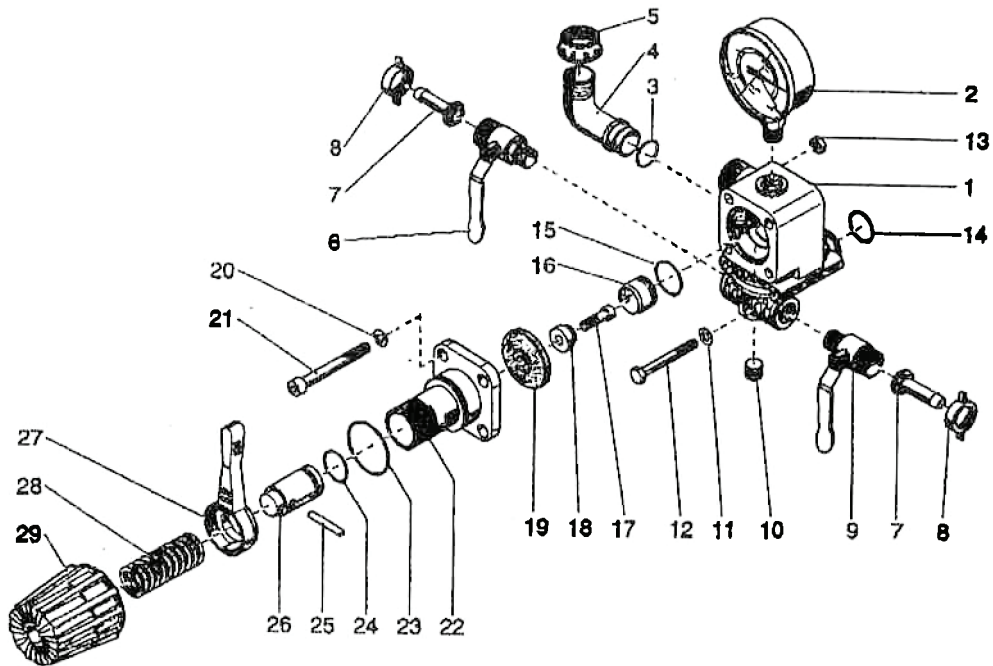

SC-1132-2 Pressure Regulator, 2 Outlets

ITEM	PART NUMBER	DESCRIPTION	QTY
1	SC-24031032	VALVE HOUSING	1
2	SC-83008000	PRESSURE GAUGE 0-100 BAR	1
2	SC-83001000	PRESSURE GAUGE 0-24 BAR	1
3	SC-80306000	O-RING	1
4	SC-84052100	90 DEGREE ELBOW CONN.	1
5	SC-82004210	WING NUT	1
6	DP-84554410	LEFT TAP	1
7	SC-84154400	OUTLET STRAIGHT PORT	2
8	DP-82001000	WING NUT	2
9	DP-84554400	RIGHT TAP	1
10	DP-85258500	CAP	1
11	DP-84358500	WASHER	2
12	SC-86241400	SCREW	2
13	SC-81452500	NUT	4
14	DP-80321800	O-RING	1
15	SC-80305900	O-RING	1
16	SC-24032051	VALVE SEAT	1
17	SC-86184150	SCREW	1
18	SC-24031951	POPPET	1
19	SC-24031336	HPS DIAPHRAGM	1
20	DP-84353900	WASHER	4
21	SC-86194420	SCREW	4
22	SC-24031132	FLANGE	1
23	SC-80307500	O-RING	1
24	SC-80317500	O-RING	1
25	SC-85114800	PIN	1
26	SC-24031453	GUIDING PISTON	1
27	SC-24031232	LEVER	1
28	SC-24031648	SPRING 40 BAR	1
28	SC-24055048	SPRING 15 BAR	1
29	SC-24032132	KNOB	1

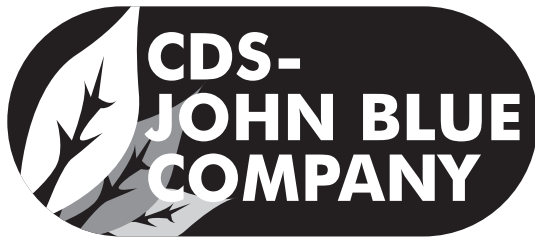

DIVISION OF ADVANCED SYSTEMS TECHNOLOGY, INC.
 165 Electronics Blvd., Huntsville, AL 35824
 Telephone: (256) 721-9090 • Fax (256) 721-9091
 Call Toll Free: 1-800-253-2583

TROUBLES AND CURES

TROUBLES	CAUSES	CURES
The pump doesn't reach the required pressure	<ul style="list-style-type: none"> • valves have worn seats • suction hose with air pockets or irregular elbows • worn nozzles or with wrong diameter (see chart) • Clogged strainer 	<ul style="list-style-type: none"> • check valves • check hoses • check nozzles • clean strainer
The pressure gauge fluctuates	<ul style="list-style-type: none"> • pump is sucking air, or air hasn't been evacuated completely • valves blocked 	<ul style="list-style-type: none"> • start pump with the gun open, to evacuate the air and commutate • clean and change valves
The liquid flow is irregular	<ul style="list-style-type: none"> • the air in the pulsation-damper is incorrectly set 	<ul style="list-style-type: none"> • check pressure in pulsation damper (see chart)
Output drops and the pump is noisy	<ul style="list-style-type: none"> • oil level is too low 	<ul style="list-style-type: none"> • top up with oil to correct level (halfway of the sump), when pump is operating
Oil comes out of the discharge pipe	<ul style="list-style-type: none"> • one or more diaphragms are broken 	<ul style="list-style-type: none"> • Drain the pump of oil. Dismantle the head and change diaphragms. Fill to the correct oil level.
Oil is changing color into white	<ul style="list-style-type: none"> • Diaphragm failures. Stop pump immediately. 	<ul style="list-style-type: none"> • Drain the pump of oil. Dismantle the head and change diaphragms. Fill to the correct oil level.

LIMITED WARRANTY

THIS WARRANTY IS IN LIEU OF ALL OTHER WRITTEN OR EXPRESS WARRANTIES AND REPRESENTATIONS. ANY IMPLIED WARRANTIES INCLUDING MERCHANTABILITY OR FITNESS FOR ANY PARTICULAR PURPOSE ARE EXPRESSLY LIMITED TO THIS WRITTEN WARRANTY. CDS-JOHN BLUE COMPANY SHALL NOT BE LIABLE FOR CONSEQUENTIAL DAMAGES.

Use of this product for any purpose other than its original intent, abuse of the product, and/or any modification to the original product is strictly prohibited by the manufacturer, CDS-John Blue Company. Any modification to the product should be approved by CDS-John Blue Company prior to use. CDS-John Blue Company will deny Warranty claims and liability in any situation involving misuse, abuse or modification.

Each new machine or component manufactured by CDS-John Blue Company through original buyer is warranted by CDS-John Blue Company to buyer and to any party or parties to whom buyer may resell, lease or lend the equipment to be free from defects in material and workmanship under normal use and service. This obligation of CDS-John Blue Company under this warranty is limited to the repair or replacement of defective parts or correction of improper workmanship of any parts of such equipment which shall within one year from the date of CDS-John Blue's original delivery thereof, be returned to CDS-John Blue's factory, transportation charges prepaid and which CDS-John Blue Company shall determine to its satisfaction upon examination thereof to have been thus defective. When it is impractical to return the defective parts of such equipment to CDS-John Blue's factory, then CDS-John Blue shall have no liability for the labor cost involved in repairing or replacing any such parts and shall be liable solely for supplying the material necessary to replace or repair the defective parts, provided that prior thereto CDS-John Blue Company shall have determined to its satisfaction that any such parts are thus defective.

This warranty shall not apply to any equipment which shall have been repaired or altered outside CDS-John Blue's factory in any way so as to affect its durability, nor which has been subjected to misuse, abuse, negligence or accident, or operated in any manner other than in accordance with operating instructions provided by CDS-John Blue Company. This warranty does not extend to repairs made necessary by the use of inferior or unsuitable parts or accessories, or parts or accessories not recommended by CDS-John Blue Company.

CDS-John Blue Company makes no warranties in respect to parts, accessories or components not manufactured by CDS-John Blue Company, same ordinarily being warranted separately by their respective manufacturers.

DIVISION OF ADVANCED SYSTEMS TECHNOLOGIES

HUNTSVILLE, AL(256) 721-9090