

S6163-C4-FSE-010

0910-LP-109-7265

TECHNICAL MANUAL
FOR

**SCOTSMAN ICE DISPENSER;
MODELS
MDT3F & MDT4F**

DISTRIBUTION STATEMENT C: DISTRIBUTION AUTHORIZED TO U.S. GOVERNMENT AGENCIES AND THEIR CONTRACTORS; ADMINISTRATIVE/OPERATIONAL USE; 1 JUNE 2006. OTHER REQUESTS FOR THIS DOCUMENT MUST BE REFERRED TO NSWC, PHILADELPHIA CODE 944.

WARNING: THIS DOCUMENT CONTAINS TECHNICAL DATA WHOSE EXPORT IS RESTRICTED BY THE ARMS EXPORT CONTROL ACT (TITLE 22, U.S.C. SEC. 2751 ET.SEQ.) OR EXECUTIVE ORDER 12470. VIOLATIONS OF THESE EXPORT LAWS ARE SUBJECT TO SEVERE CRIMINAL PENALTIES.

DESTRUCTION NOTE: DESTROY BY ANY METHOD THAT WILL PREVENT DISCLOSURE OF CONTENTS OR RECONSTRUCTION OF THE DOCUMENT.

PUBLISHED BY DIRECTION OF COMMANDER, NAVAL SEA SYSTEMS COMMAND

31 DEC 2009

MDT3F and MDT4F Manual

Purpose of this manual: To provide detailed installation and operation instructions; to give insights into how the machine works; to list possible causes for problems; and to suggest procedures for specific types of service.

The MDT3F and MDT4F are combination ice makers and dispensers. The refrigeration system is air cooled, using R-134a as a refrigerant. The control system uses electric eyes as a bin control and a water level sensor as the water safety control. As ice is made, it fills a plastic storage bin. When ice is needed, a motor rotates a stainless steel vane inside the storage bin and sweeps the ice into the spout.

New Table of Contents

Specifications: Page 2

To The Installer: Page 3

For The Electrician Page 4

For The Plumber Page 5

Wall Mount Kit (KWB4): Page 6

Final Check List & Initial Start Up Page 7

User Operation Page 8

Component Location & Function Page 9

Refrigeration System Operation Page 10

Water System Operation: Page 11

Mechanical Operation Page 12

Electrical Sequence Page 13

Maintenance: Page 14

Dispense Area Sanitation Page 15

Auger and Bearing Inspection Page 16

Inspection: Auger Page 17

Inspection: Page 18

Service Diagnosis Page 19

Service Diagnosis Page 20

SERVICE DIAGNOSIS: Circuit Board Page 21

Removal and Replacement Page 22

Water System Page 23

Bearings, Water Seal and Auger Page 24

Bearing Replacement: Page 25

Refrigeration System Page 26

Gear Reducer Removal Page 27

Auger Drive Motor Page 28

Parts Lists and Wiring Diagrams are printed on yellow paper in the center of this manual.

This manual was printed on recycled paper. Keep it for future reference.

MDT3F & MDT4F

Specifications:

Scotsman ice machines, like the MDT3F or MDT4F, are designed to be installed indoors, in a controlled environment. The minimum and maximum operating conditions are:

- Minimum Air Temperature: 50°F.
- Maximum Air Temperature: 100°F.
- Minimum Water Temperature: 40°F.
- Maximum Water Temperature: 100°F.
- 60 Hz voltage may vary between 104 and 126 volts.
- Water Pressure may vary between 20 and 80 psi.

Operating the machine outside these conditions constitutes misuse and voids the warranty.

Scotsman Ice Systems are designed and manufactured with the highest regard for safety and performance. They meet or exceed the standards of UL, NSF and CUL.

Scotsman assumes no liability or responsibility of any kind for products manufactured by Scotsman that have been altered in any way, including the use of parts and/of other components not specifically approved by Scotsman.

Scotsman reserves the right to make design changes and/or improvements at any time. Specifications and designs are subject to change without notice.

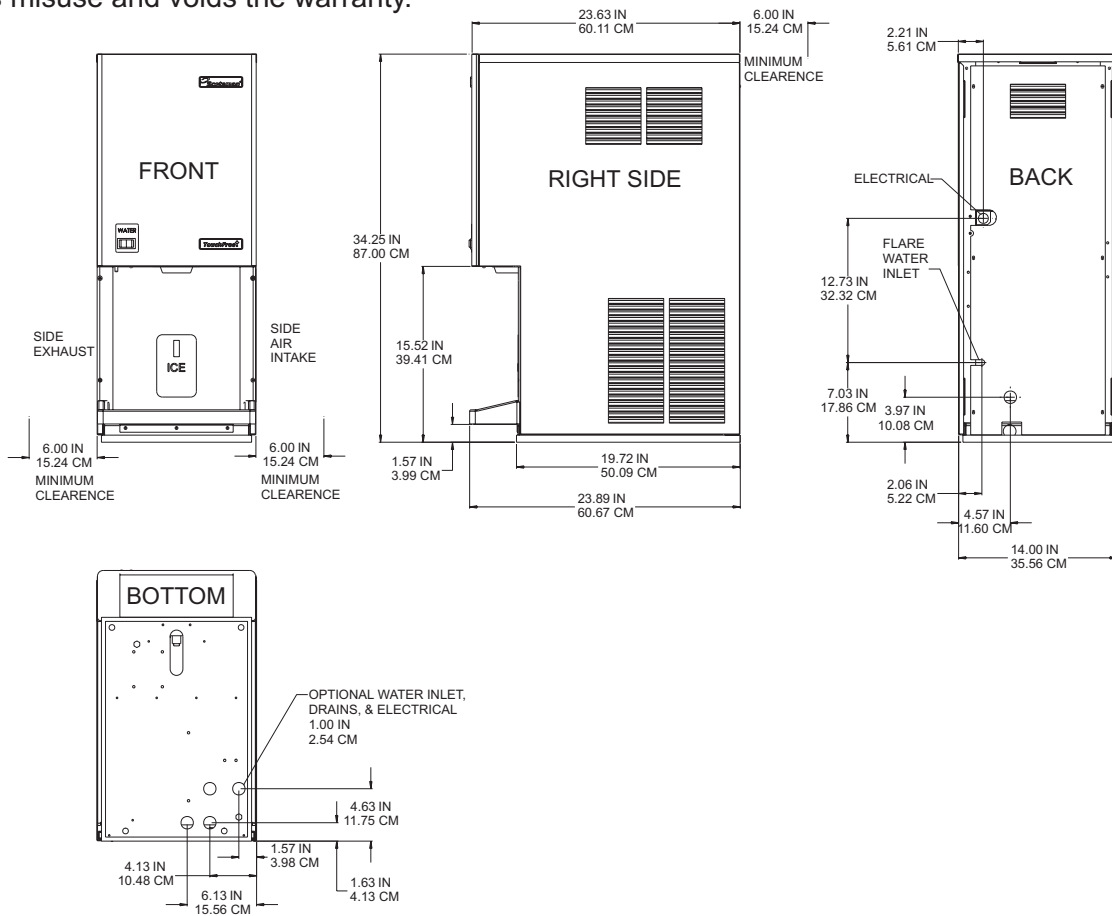

Specifications:

Model Number	Dimensions W" x D" x H"	Basic Electrical	Refrigerant Charge (R134a)	Min. Circuit Ampacity	Max Fuse Size
MDT4FA-1A	14 x 23 / x 34 1/4	115/60/1	14 oz.	15.1	20
MDT4FA-6A	14 x 23 / x 34 1/4	230/50/1	14 oz.	7.5	15
MDT3FA-1A	14 x 23 / x 34 1/4	115/60/1	12 oz.	9.4	15
MDT3FA-6A	14 x 23 / x 34 1/4	230/50/1	12 oz.	5.3	15

To The Installer:

A professional installation of any product is critical to the long term satisfaction of the user. The ice maker-dispenser is designed to be installed either on a counter, or, using a wall hanging kit, hung from a wall.

Determine the location from the anticipated use and any options planned for.

This machine is air cooled and blows air out the lower left side of the cabinet. Do not install the machine where the side to side air flow might be blocked.

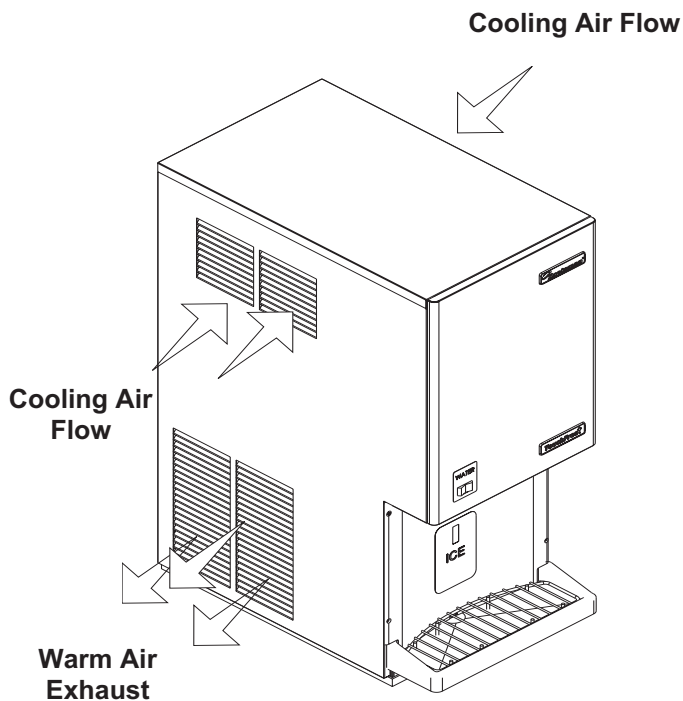

The machine will require electrical power, water and a drain. Follow all local codes. Rough in the utilities before placing the machine into position (see For The Electrician and For The Plumber).

Water Quality:

The quality of the water supplied to the machine will directly affect the purity of the ice and the reliability of the machine. While the condition of the water supplied to a building is normally out of the control of the user, water can be treated at the point of use.

There are two major types of water impurities: suspended solids (those that are carried along with the water and may be filtered out) and dissolved solids (those that are part of the water and have to be treated). A water filter is always a good idea, but does require regular maintenance to change the cartridge. In some water conditions, water treatment may be required. Generally this means a polyphosphate feeder of some kind. Water softeners are not recommended.

General Installation:

Place the machine in its final location. Remove the top, right and left side panels:

1. Remove two screws at the back of the top panel.
2. Pull up on the back of the top panel and remove it.
3. Remove screws from the sides (top and bottom) of the side panels and from the splash panel.
4. Pull the side panels back and off the machine.

Plumbing connections may be made thru holes in the back of the cabinet or thru the base.

- Route the sink drain to the back of the cabinet. Route the bin drain to the back panel.
 - Route the electrical power cord from the junction box inside the cabinet. thru the back panel .
 - Route the inlet water line thru the back panel or base to the flare fitting inside the cabinet.
- Install the stainless steel panel kit (if used) now.

Install the back panel of the stainless steel panel kit now (if used).

After all plumbing and internal wiring has been done, replace the side and back panels.

Level the unit front to back and left to right.

The machine does not require sealing to the counter due to the gasket on the base.

MDT3F & MDT4F

For The Electrician

Electrical connections:

Check the nameplate for voltage and current requirements. An electrical cord is not supplied. Connect the MDT3F or MDT4F to a separate electrical circuit. Wiring to the machine must conform to all codes. A licensed electrician may be required in some situations.

Remove the back panel to make the electrical connection. The electrical connection is made on the terminal strip in the junction box inside the machine. Replace the back panel when the electrical connections are complete.

**FOLLOW ALL APPLICABLE LOCAL, STATE
AND NATIONAL CODES
This Unit MUST BE GROUNDED**

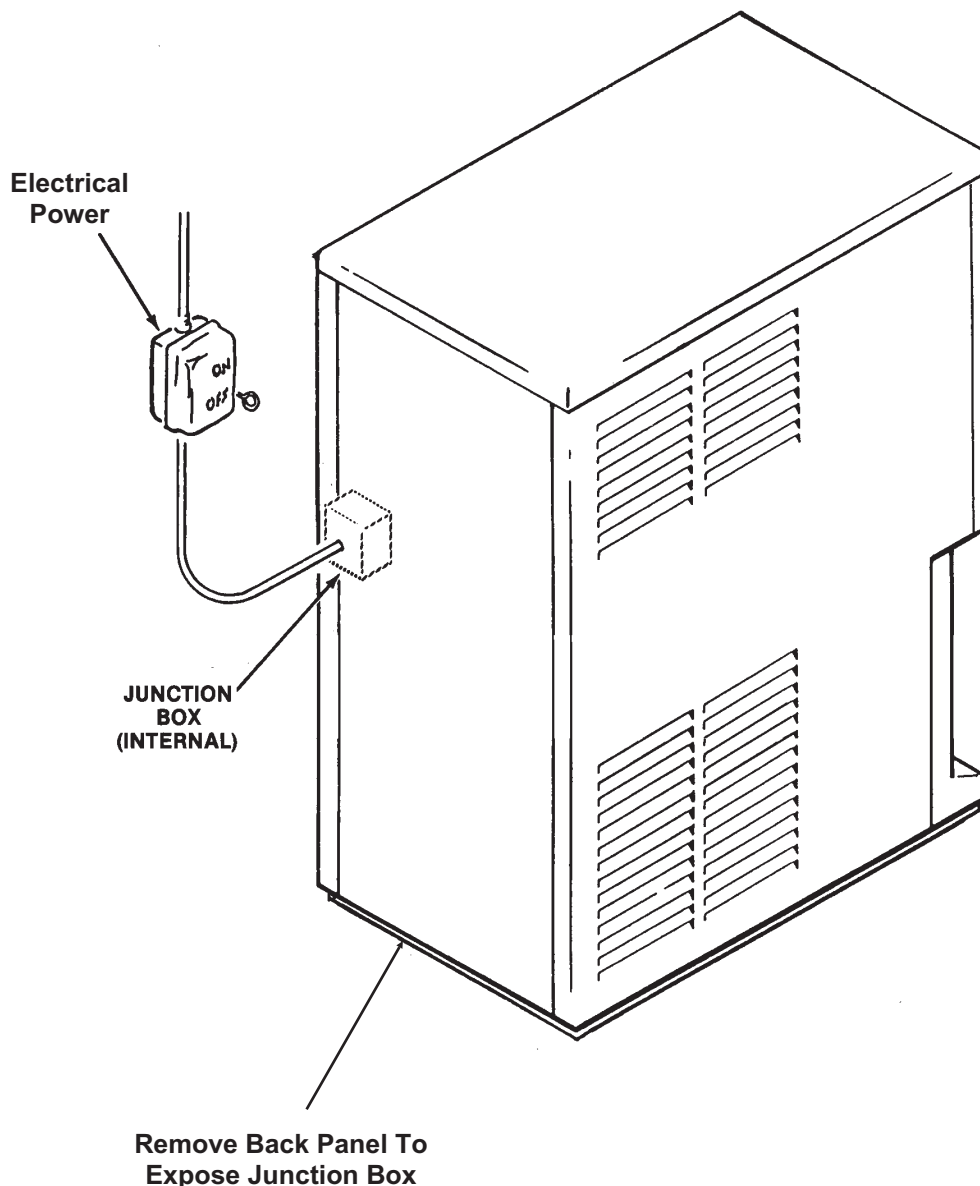

For The Plumber

Drains:

The dispenser requires a gravity drain. The pitch on the drain tubes must be at least ¼ inch fall per foot of horizontal run. On long horizontal runs, a vent at the back of the cabinet will improve draining, and is recommended.

There are two drains to connect: A sink drain, a 7/8" plastic tube; and the bin drain, a 5/8" plastic tube. Install rigid tubing between the machine and the building drain. Route the drains separately to the building drain.

Water supply:

Connect cold, potable water to the machine. A hand valve near the location is recommended. A water filter is also a good idea.

Follow all local codes.

FOLLOW ALL APPLICABLE LOCAL, STATE AND NATIONAL CODES

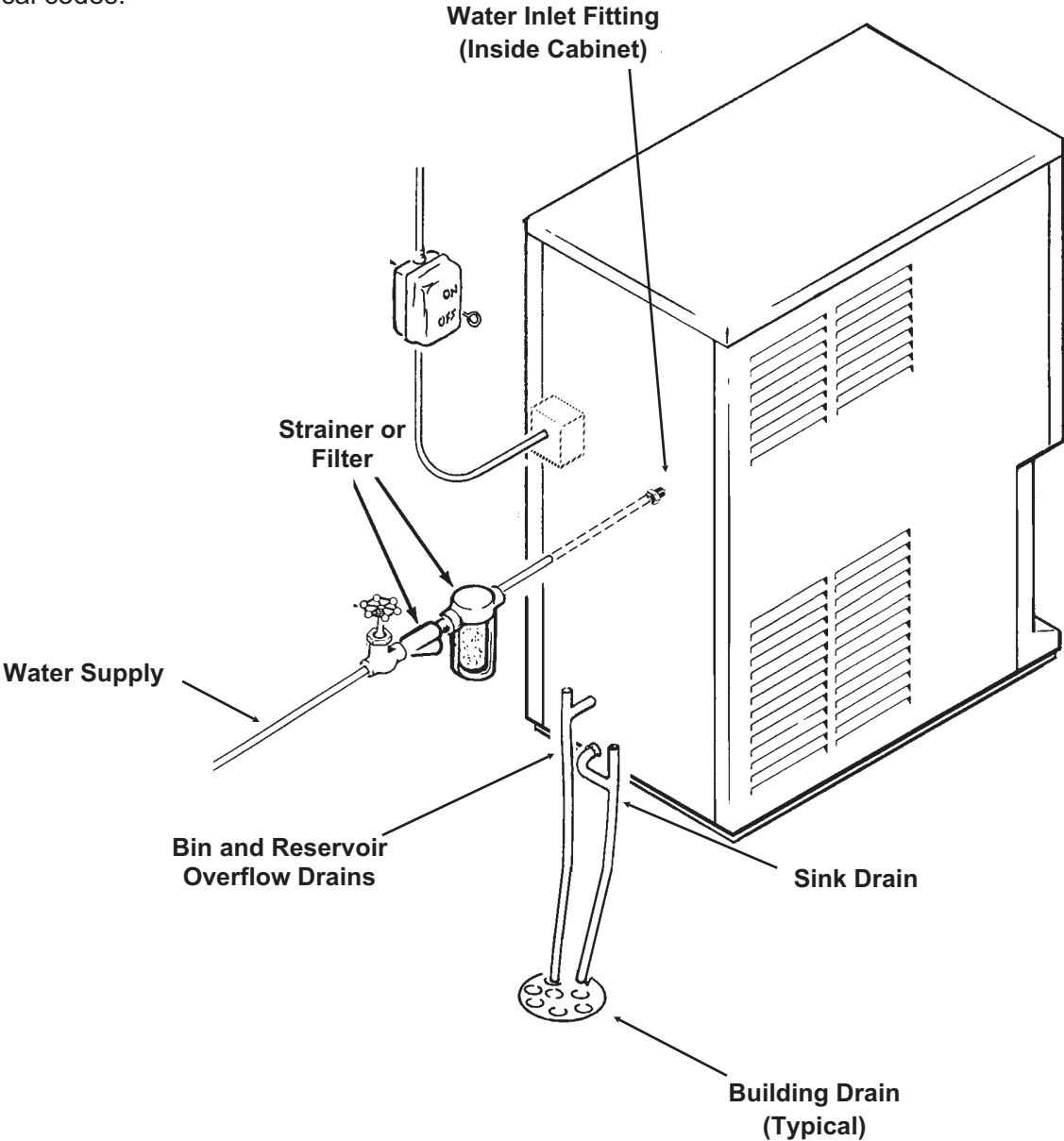

MDT3F & MDT4F

Wall Mount Kit (KWB4):

Contents:

1. Top Case Hanger Bracket: Attaches to the frame of the dispenser.
2. Top Wall Bracket: Mounts to the wall and engages the top case hanger bracket to support the dispenser.
3. Bottom Wall Bracket: Mounts to the wall and spaces the base of the dispenser away from the wall.
4. Bottom Fittings Cover: Fastened to the bottom wall bracket to hide the utility connections.

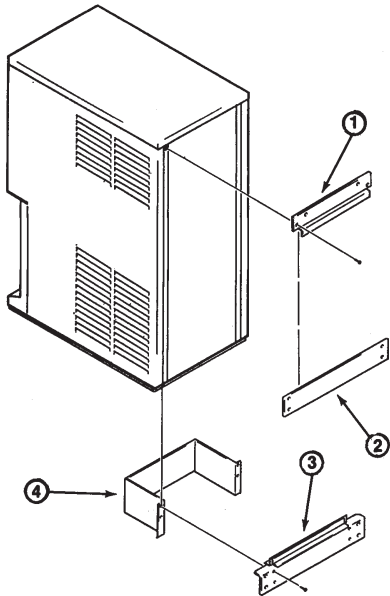

Installation: Check building wall for the strength required to support a machine of this weight and size. Note that if at least 6" of space is not left above the machine, cleaning and most service of the machine will require removal of the machine from the wall mounts. All utilities are to be routed thru the base. The back panel is not used when the machine is hung from the wall.

Top Case Hanger Bracket

1. Remove top panel.
2. Remove back cover and save the 4 screws for mounting the bracket.
3. Drill out the holes (as marked in the illustration) in the back of the frame with a 3/16" drill bit.
4. Place top hanger bracket on the inside of the frame and fasten to the frame with the four screws removed in step 2.

Top Wall Bracket:

1. Hold the bracket on the wall where it will be mounted.
2. Mark on the wall the positions of the holes in the bracket.
3. If needed, drill pilot holes for the fasteners.
4. Secure the bracket to the wall with fasteners of sufficient strength to hold up the MDT4F.

Bottom Wall Bracket:

1. Lift up and hang the dispenser from the top wall bracket.
2. Position the bottom wall bracket so that the molding on the dispenser base bottoms in the channel of the wall bracket.
3. Secure the bracket to the wall.

Bottom Fitting Cover:

1. Connect electrical power, water inlet, bin drain and sink drain of the dispenser thru the bottom of the case.

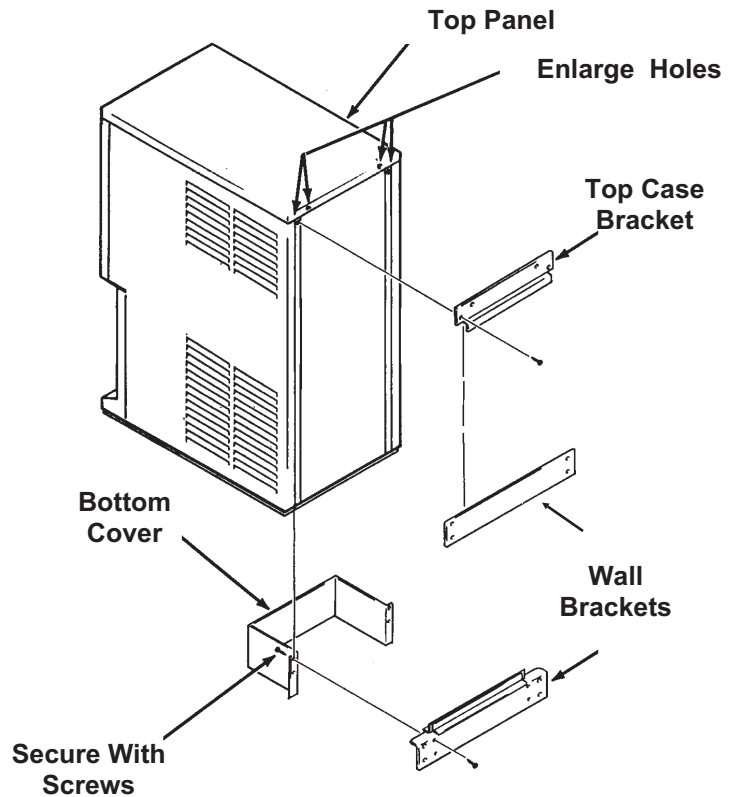

2. Secure bottom fitting cover to the bottom wall bracket with the four sheet metal screws provided in this kit.

Final Check List & Initial Start Up

1. Is the machine located indoors where the temperature limitations are not exceeded?
2. Is there at least 6" clearance on both sides of the cabinet for adequate air flow?
3. Is the water supply adequate, and has a shut off valve been installed?
4. Is the cabinet level?
5. Have all of the electrical and drain connections been made?

Initial Start Up

1. Remove 2 screws at the back of the top panel and remove the top panel.
2. Remove screws and the side panels.
3. Open the water supply shut off valve.
4. Watch the water fill the reservoir. Check that it flows in and fills the reservoir near to the mark molded into the side of the reservoir. Check that the float shuts off the water flow when the tank is full. Check for leaks. Tighten hose clamps as needed.
5. Plug the unit in or switch on the electrical power. After about 15 seconds the machine should start.
6. Let the machine operate, listen for any unusual noises. If needed, reposition tubing & panels to eliminate vibration.

After the unit has been operating for about 10 minutes, there should be enough ice in the bin to test the dispense system.
7. Using a container, place in in front of the glass sensor and below the ice chute. See that ice is dispensed (the bin drive motor continues to run as long as the container is in place).
8. Move the water switch (rocker switch on the front panel) to ON. Place the container in front of the glass sensor and under the ice chute. Both water and ice should be dispensed.
9. Pour water into the sink and check that the drain does not leak but drains the water rapidly.
10. Explain to the user the maintenance requirements and operation of the machine.
11. Fill out the Warranty Registration and Customer Evaluation form. Mail it to Scotsman.
12. Leave the service manual with the owner/user and explain who should be called if service is needed.

MDT3F & MDT4F

User Operation

The MDT3F and the MDT4F are automatic ice vending machines. All either requires is cool air, clean water and an adequate supply of electrical power.

To Vend Ice:

Place a container in front of the Touch Free sensor and below the ice spout. Hold it there until the container is full of ice. Do NOT overfill the container or a build up of ice in the sink or a back up of ice in the spout will occur.

To Vend Ice and Water.

Switch the Water Switch to ON. Place a container in front of the Touch Free sensor and below the ice spout. Water and ice will be dispensed into the container below the spout. Note: The water is NOT cooled, it is the same temperature as the building supply water.

Daily Maintenance: Pour hot water into the sink to flush out any debris or build up. Wipe the cabinet off, wash the sink and grill to keep minerals from accumulating.

Caution:

Unless the touch free sensor is de-activated by pushing the Cleaning Switch in, ice and/or water may be dispensed during cleaning.

The Cleaning Switch is a button, located to the left of the ice chute, that temporarily shuts off the sensor for cleanup of the splash panel.

Pushing the button in will disable the sensor for 2 minutes, pushing the button in again will return the sensor to normal operation.

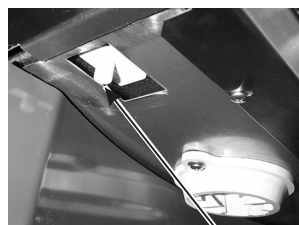

Touch Free
Disable
Switch

Water
Switch

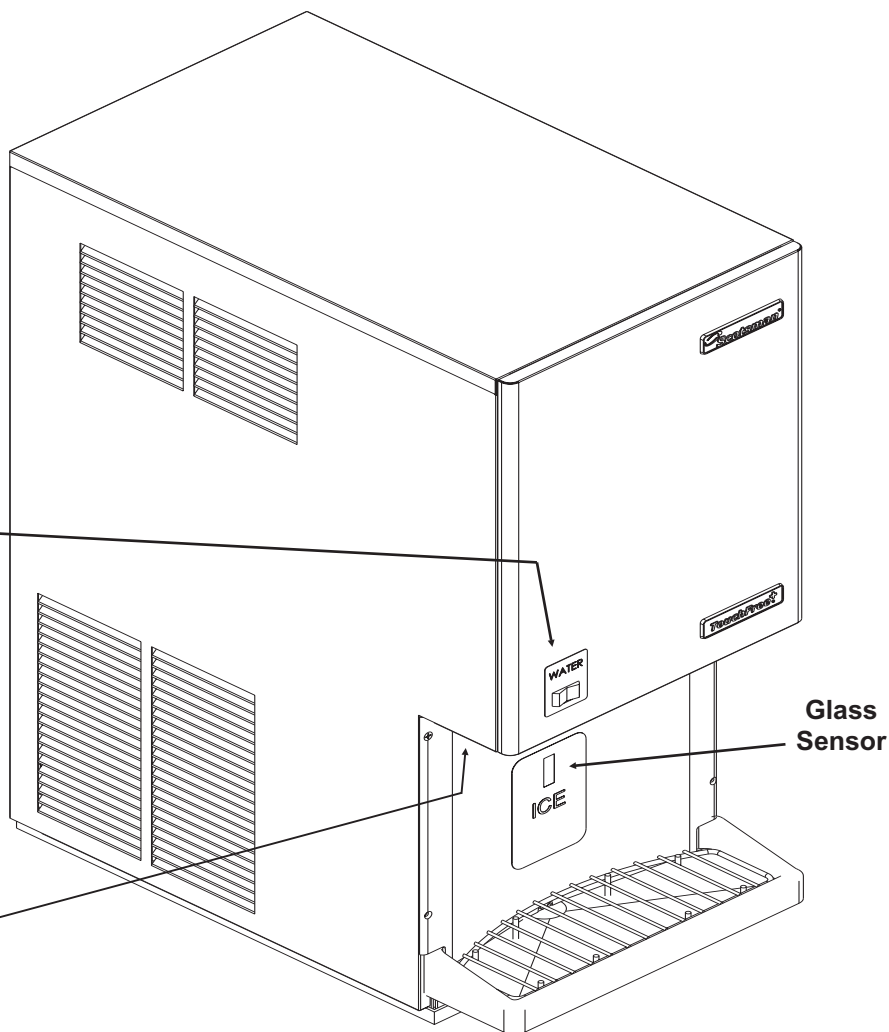

Glass
Sensor

Component Location & Function

Evaporator. This is a vertical cylinder full of water and refrigerated. Also in the cylinder is a slowly rotating auger. The auger forces the ice up the evaporator walls and compresses it at the top. The resulting flaked ice then falls by gravity into the ice storage bin.

Water Reservoir. The water reservoir contains the inlet float valve and the water level sensor. The float valve controls the flow of water into the reservoir, and the water level sensor will stop the ice maker if the water supply fails.

Ice Storage Bin. The ice storage bin is an insulated plastic container that is open at the top and has a spout at the bottom. There is a rotating ice vane inside the bin that causes the ice to be swept over the spout and dispensed. The vane is rotated by a gear motor at the top of the bin.

Bin Cover. The bin cover not only keeps dirt from the ice storage bin, it also is the support for the dispense gear reducer and the location of the electric eye bin controls.

Condenser. The machine uses an air cooled condenser. It blows air out, away from the fan motor. The heat removed from the water is exhausted from the condenser.

Compressor. The refrigeration system compressor provides the force to move the refrigerant around the system.

Auger Drive. The auger drive is a direct drive gear reducer.

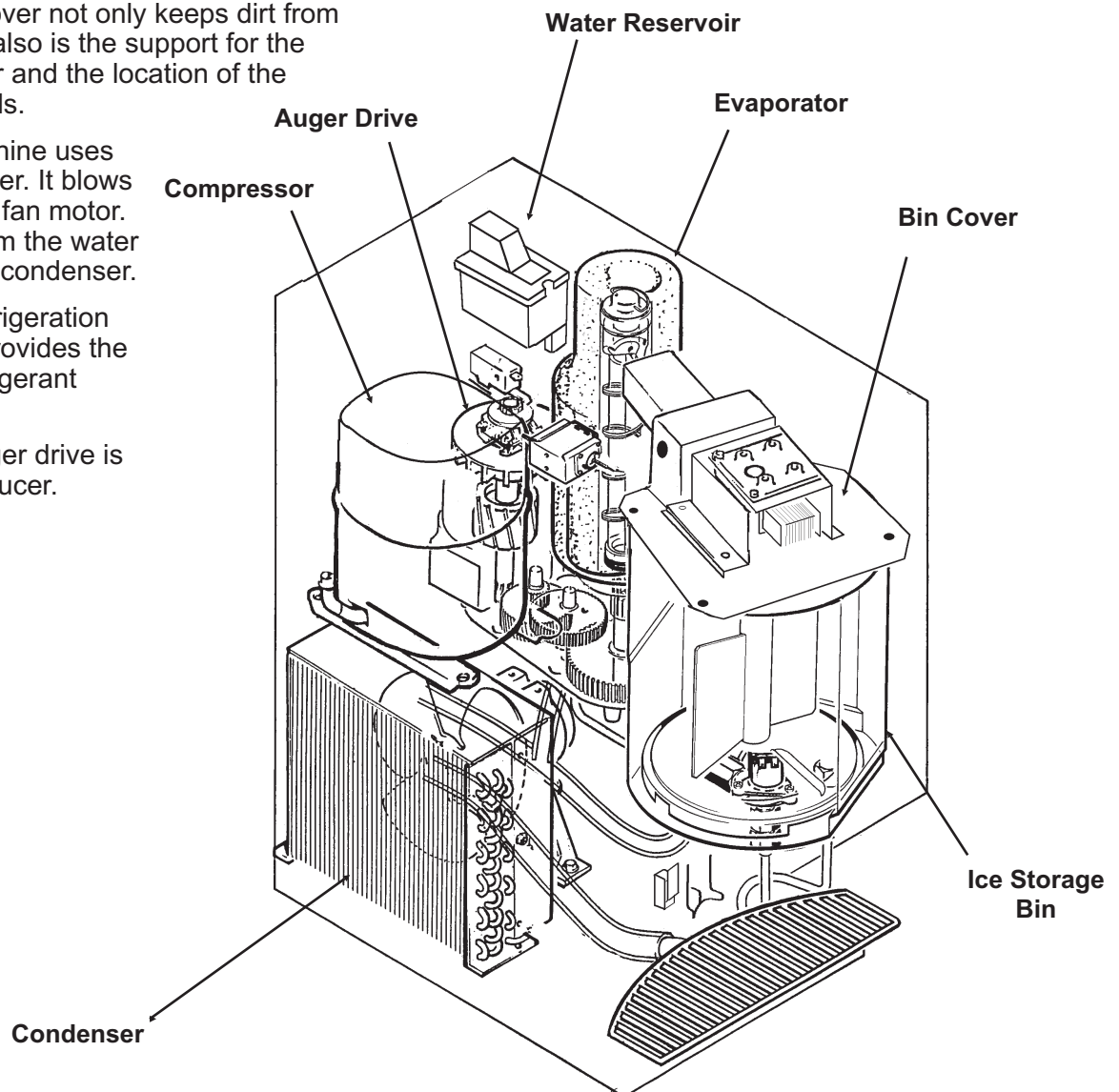

MDT3F & MDT4F

Refrigeration System Operation

Both the MDT3F and the MDT4F use a forced draft condenser, capillary tube and hermetic compressor. The system uses R-134a as a refrigerant. High pressure, high temperature refrigerant is forced thru the condenser where it loses enough heat to condense. The high pressure liquid refrigerant then passes thru the capillary tube which causes a pressure drop in the evaporator. As the high pressure liquid refrigerant moves into the evaporator's area of low pressure, the warm water and low pressure cause the refrigerant to evaporate and absorb heat from the metal walls of the evaporator. After the refrigerant has flowed thru the evaporator it goes back to the compressor thru the suction line as a low pressure vapor. At the compressor the cycle is repeated.

System Characteristics:

- Typical Low Side Pressure:
13 - 14 PSIG
- Typical Discharge Side Pressure:
135 - 175 PSIG
- System Refrigerant Charge:
14 ounces of R-134a

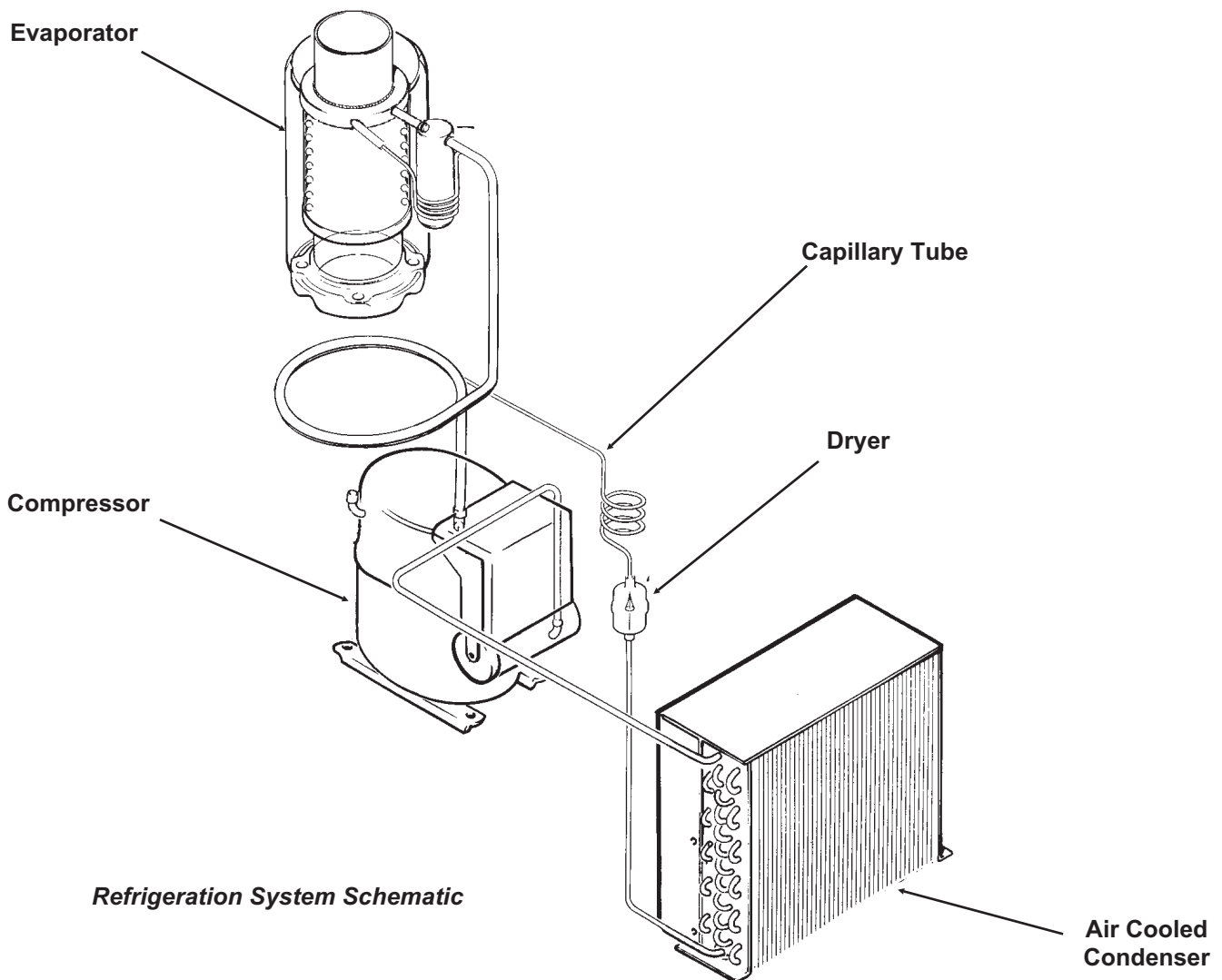

Refrigeration System Schematic

Water System Operation:

The water system consists of a float valve, reservoir and water dispense solenoid valve. The water level in the reservoir tank is the same level as that inside the evaporator. Building water supply flows to both the float valve and the solenoid. The float valve will open to add water to the reservoir as water flows out to the evaporator. The solenoid will only open if the water switch is closed and the touch free sensor initiates an ice dispense.

Inside the evaporator there is a water seal. This seal is the type that has a rotating half and a stationary half. The area where the two seals touch are smooth flat surfaces. When the auger is installed in the evaporator, it forces the rotating half of the seal against the stationary half. The stationary half is spring-loaded and provides a firm pressure against the auger portion of the seal.

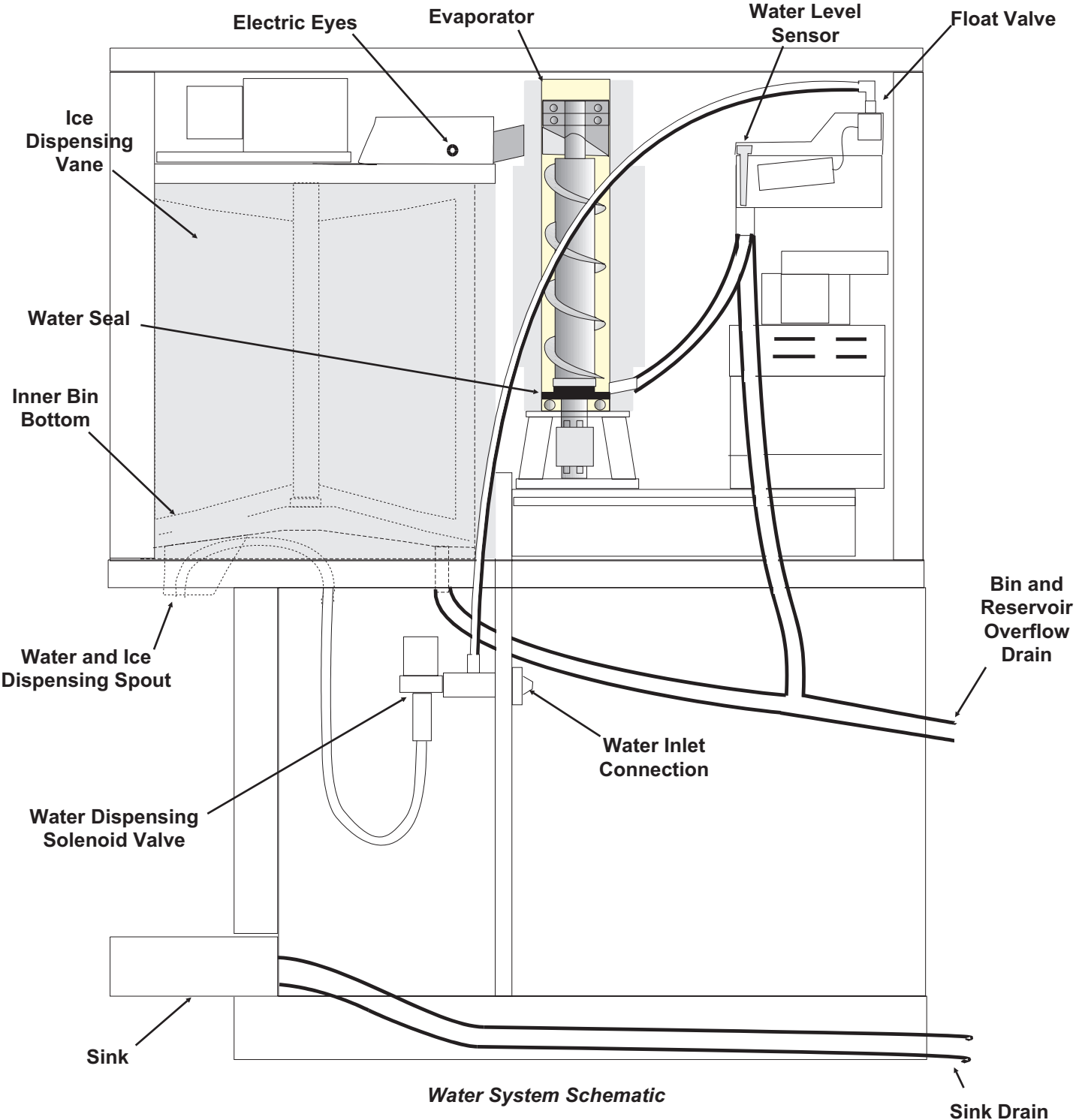

Water System Schematic

MDT3F & MDT4F

Mechanical Operation

General:

The machine makes, stores and dispenses ice. It also dispenses water. The ice making portion of the machine produces flaked ice at about 32°F. The ice falls thru a chute into the dispensing bin. Above the cylindrical bin is a dispense drive motor and electric eyes. The drive motor is connected to an ice vane in the bin. When the user holds a container in front of the glass sensor and below the ice chute, the dispense drive motor rotates the vane and the ice. There is a slot in the base of the bin, located just above the vend spout and glass filler lever. When the ice moves over that slot, some of the ice on the bottom of the bin falls thru the slot, into the chute and fills the container.

ON/OFF Control:

Flaked ice is produced by the ice maker until ice builds up between the electric eyes. When the electric eyes can no longer “see” each other, they send a signal to the control board to shut the machine off. The refrigeration compressor stops but the auger drive motor will continue to operate for about 2 minutes to clear the evaporator of ice.

Water Control:

Because water is such an important requirement for making ice, a water level sensor has been placed in the reservoir. If the water supply to the machine should fail, the water level sensor will send a signal to the control board to shut down the machine.

Refrigeration:

The refrigeration system uses a hermetic compressor (specifically designed for R-134a), forced draft air cooled condenser, capillary tube and vertical flaked ice evaporator. Inside the evaporator is a slowly rotating auger. The auger is supported by bearings at each end, and there is a face-type water seal above the bottom bearing. The auger is driven by a 1/10 HP direct drive gear reducer. The auger drive motor has a speed operated switch on it that will keep the compressor from operating if the auger motor is not turning at full speed.

Water System

Water flows from the building supply to the reservoir and to the electric solenoid valve. Water from the reservoir is used to make ice. Water the flows thru the solenoid is dispensed.

The bin, sink and reservoir overflow all have drains.

Ice Vending

Dispensing takes place when the touch free sensor's infrared beam bounces back to the sensor from a container placed directly in front of the sensor and under the ice chute.

When the beam is reflected back, it signals the circuit board to connect power to the dispense drive motor, and ice is then moved over the slot in the base of the bin, where it falls by gravity thru the chute into the container.

If the Water switch is On, water is also dispensed at the same time.

Dispensing continues until the beam is no longer reflected back to the sensor.

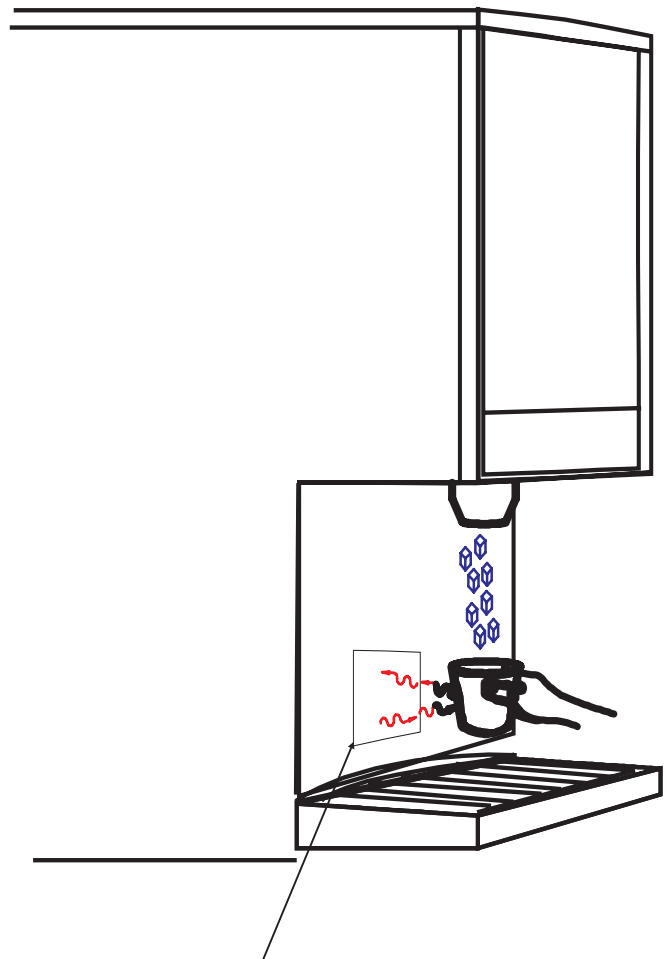

Touch Free Sensor

Electrical Sequence

Refer the wiring diagram as needed.

The “Power” light on the board glows whenever there is power to the machine (and the master switch is ON).

If the machine is switched off at the master switch, but is otherwise ready to go, switching the master switch to ON does the following:

- The bin empty and power lights on the circuit board glow.
- There is a 15 second delay
- If there is enough water in the reservoir, the circuit board will allow the machine to start up.

Start up consists of:

- The compressor contactor coil receives power from the circuit board.
- The contactor is energized, connecting power to the compressor, and the compressor starts.
- The auger motor receives power from the circuit board and starts.
- As ice goes past the ice level sensors, the bin empty light will stay on and the machine will continue to run, unless the ice stays between the sensors for more than 15 seconds (bin full). At that point, the bin empty light goes out, and the machine shuts down.

Other reasons for shut down:

- Low water level (as sensed by the thermistor in the reservoir).

Shut Down consists of:

- The compressor contactor opens
- The compressor stops
- The auger motor is run by the circuit board for 2 more minutes, clearing out ice in the evaporator, and then
- The auger motor no longer receives power from the circuit board, and the auger motor stops.

After a 6 minute delay, If the ice level sensor is clear (bin empty) for more than 15 seconds, the machine will start up again.

Another purpose of the circuit board is to turn the machine off if there is not enough water in the machine.

- When the water level in the reservoir falls below the tip of the water level sensor, the machine will “shut down”
- After a 6 minute delay, if the water refills the reservoir, the machine will start up again.

Ice Vending

- When a user places a container in front of the Touch Free ice sensor and below the ice delivery chute, the circuit board connects power to the bin drive motor and ice is dispensed for as long as the container is present. If the user does not remove the container, ice will be dispensed for 60 seconds and then stop.
- When a user selects water and ice dispensing, water is also dispensed with the ice.

Splash panel cleaning:

A switch, located to the left of the spout, may be pushed to disable the Touch-Free sensor for splash panel cleaning. It automatically resets after 2 minutes, or, if pushed within the 2 minutes, resets the circuit board to enable the Touch Free sensors.

MDT3F & MDT4F

Maintenance:

Although the ice in this dispenser is completely untouched, the water and ice vending systems will need to be periodically sanitized and de-mineralized. The air cooled condenser will also need to be kept clean.

Schedule the sanitation, cleaning and de-mineralization on a regular basis to keep the ice clean and the machine operating efficiently.

Sanitation and Cleaning

Water System:

This ice machine requires periodic sanitation and de-mineralization.

1. Vend all ice from the machine.
2. Remove top and right side panels.
3. Unplug or disconnect electrical power.
4. Shut off water supply.
5. Drain reservoir.
6. Mix 8 ounces of Scotsman Ice Machine Cleaner and 3 quarts of hot (95°F. -115°F.) potable water.

Scotsman Ice Machine Cleaner contains acids. These compounds may cause burns.

If swallowed, DO NOT induce vomiting. Give large amounts of water or milk. Call Physician immediately. In case of external contact, flush with water.

KEEP OUT OF THE REACH OF CHILDREN.

WARNING

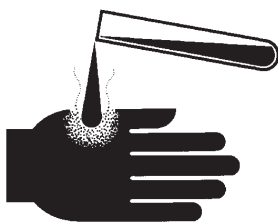

7. Pour the water into the reservoir.
8. Wait 15 minutes for the cleaner to dissolve the minerals inside the evaporator.
9. Plug in the machine or reconnect electrical power.
10. As the machine operates, pour in the balance of the cleaning solution.
11. Reconnect water supply, operate the machine for 15 more minutes, then switch it off.

12. Repeat steps 3-11, except substitute a locally approved sanitizing solution for the cleaner. A possible sanitizing solution may be obtained by mixing 1 ounce of household bleach with 2 gallons of clean, warm (95°F.-115°F.) water.

13. Unplug or disconnect electrical power.

14. Remove bin top, pour in warm potable water to melt out any ice.

15. Pull out the vane and bin bottom from the bin.

16. Thoroughly wash the bin's interior, bin top interior, spout, ice vane and bin bottom with the sanitizing solution. Pour some down the bin drain.

17. Reassemble the bin bottom, vane and bin cover.

18. Wash the sink area with the sanitizing solution and pour sanitizing solution down the sink drain.

19. Replace all panels and reconnect water and electrical power.

Air Cooled Condenser:

1. Disconnect electrical power.
2. Remove top panel
3. Remove right and left side panels.
4. Use pressurized air to blow the lint from the outside of the condenser in towards the fan motor. A vacuum cleaner hose placed on near the fan motor should pick up most of the dust. Check for interior dirt. If needed, use coil cleaner to de-grease the condenser.
5. Replace all panels and reconnect electrical power.

Dispense Area Sanitation

1. The spout may be removed by taking out the two mounting screws. Wash and sanitize it.
2. The sink grill may be removed for washing and sanitizing.
3. The sink should be flushed with hot water and wiped clean with sanitizer.
4. The splash panel requires special attention to clean it.
 - Push and release the Cleaning Switch located to the left of the ice spout. This disables the Touch Free Sensor so the splash panel may be cleaned without vending ice or water.
 - Wash the splash panel and wipe with sanitizer.
 - Re-push the clean switch or allow 2 minutes to pass for the Touch Free system to reset.

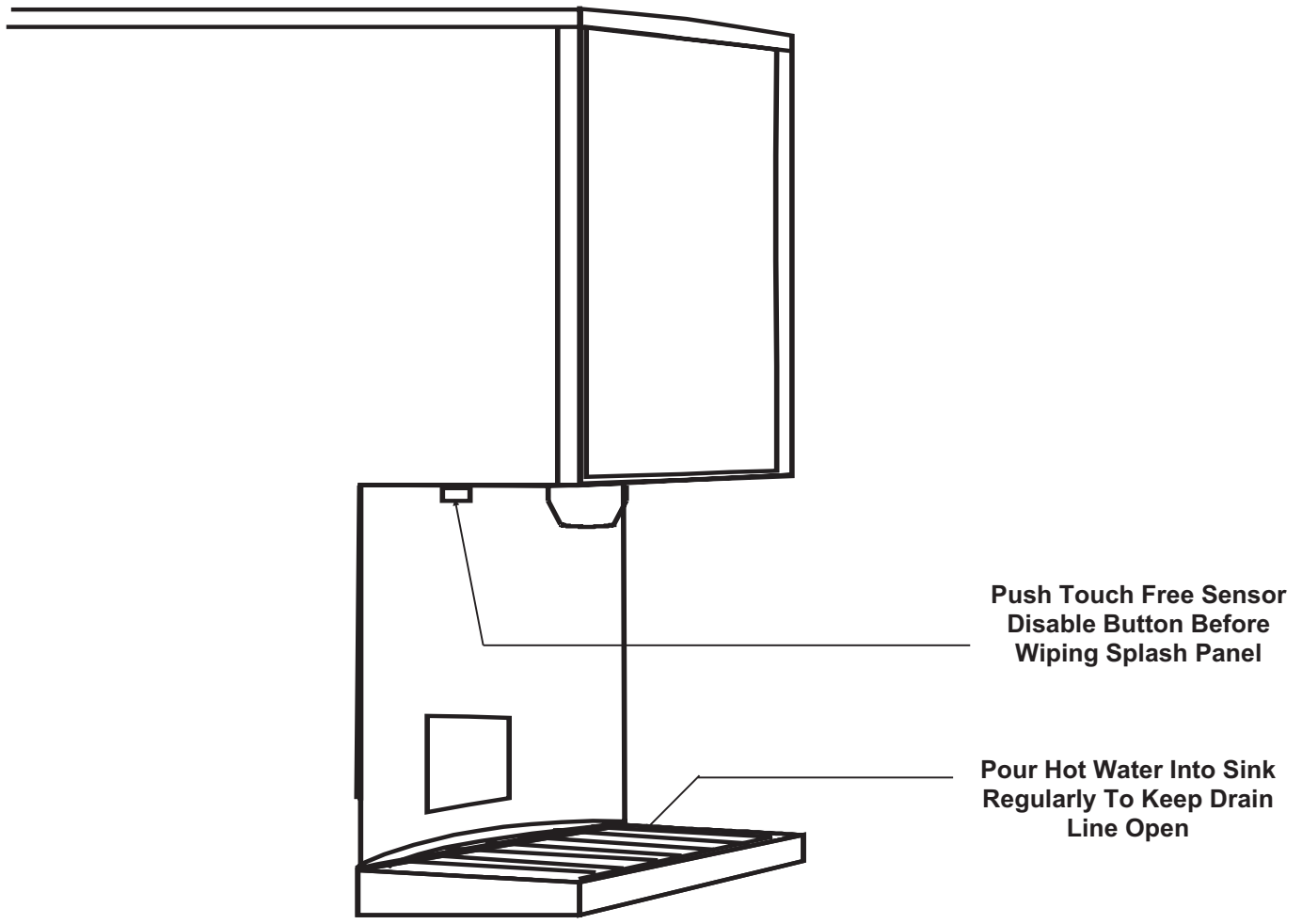

MDT3F & MDT4F

Auger and Bearing Inspection

While in most areas regular in-place cleaning with Scotsman Ice Machine Cleaner will be adequate to keep the interior of the evaporator free of excessive mineral build up, some water conditions may require more intense methods. In addition, the auger bearings require physical inspection to determine that they are not wearing. This physical inspection is recommended twice per year for the top bearing and once per year for the auger and both bearings.

Whenever the auger is removed, replacement of the water seal is recommended.

If a bearing requires replacement, the other bearing must also be replaced.

1. Unplug or disconnect electrical power.

Rotating Parts Hazard Disconnect Electrical Power Before Beginning	CAUTION
---	----------------

2. Shut off the water supply.
3. Remove top panel.
4. Remove right side panel.
5. Drain the evaporator and reservoir.
6. Remove foam cap on top of evaporator.
7. Remove 2 permagum plugs from the side of the evaporator.
8. Remove 2 screws (screwheads were covered by the permagum).
9. Pull up on the pull ring to remove the auger. If it is difficult to pull:
 - A. Remove the breaker cover by taking the snap ring out.
 - B. Unscrew the auger bolt.
 - C. Use threaded rod or a slide hammer puller and screw into the auger, slide the weight quickly up against the stop to remove the auger.

If the auger still will not move, bearing replacement is mandatory. See Bearing Removal and Replacement.

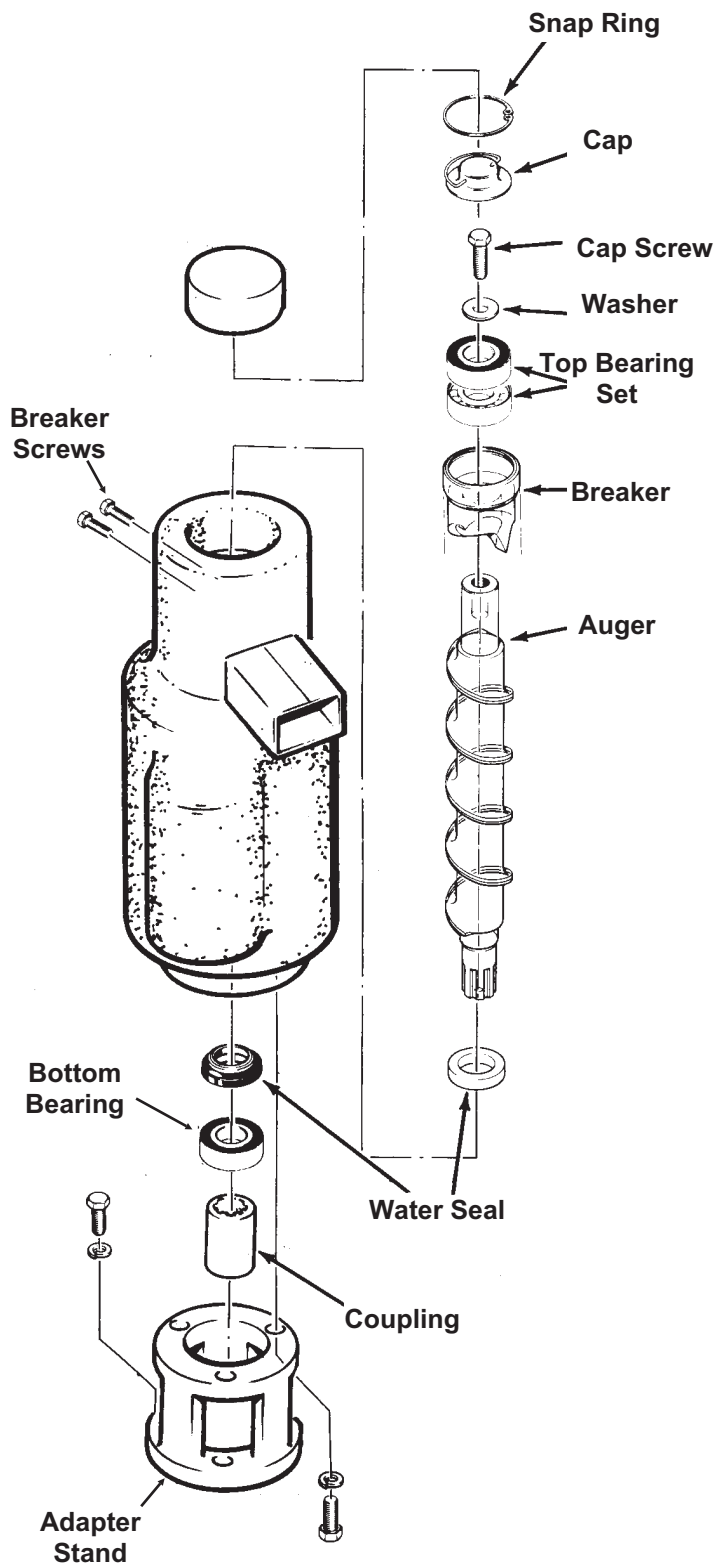

Inspection: Auger

The auger is made of stainless steel. It has a polished surface that may be either shiny or dull, but must be smooth. After removal, allow the auger to dry to inspect for scale. If mineral scale is found on the auger's surface, clean off the auger with ice machine cleaner and a scrubbing pad.

Remove the water seal and clean off the shoulder of the auger.

Bearings: The top bearing should spin freely with no rough spots. If it feels rough when spun by hand, replace it. There should be minimal rust or dirt. If in doubt, replace the bearing.

Note: The top bearing used in the MDT3F and MDT4F is a "directional" bearing. Note which way the inner race is configured and install into the breaker. The breaker is also available as a replacement part with the top bearing already installed.

The bottom bearing must be removed from the evaporator when replacing the water seal.

To replace the water seal:

1. Remove old rotating half from the auger. Clean the mounting area.
2. Place a bead of food grade sealant (such as Scotsman part number 19-0529-01) onto the shoulder of the auger where the rotating half of the water seal will be installed.
3. Wash the new seal in water. While wet, slip it onto the bottom of the auger, rubber side toward the auger. Push up until seated against the sealant. Do not allow any sealant to come into contact with the face of the seal.
4. Wash the stationary half the water seal with water. Slip it up into the bottom of the evaporator until the bottom of the seal is inside the evaporator about 1/4".
5. Push the bottom bearing against the water seal until the bottom bearing is inside the evaporator about 1/16".
6. Replace the evaporator on the adapter, and re-attach the stand using the original bolts.

Remove the three bolts holding the evaporator to the gear motor adapter and lift the evaporator up slightly. Tap the water seal and bottom bearing out from the top down. Check the bottom bearing (the same way as the top one).

Replace the water seal and install a new bearing set if needed.

Sealant Here



Remove bin cover.

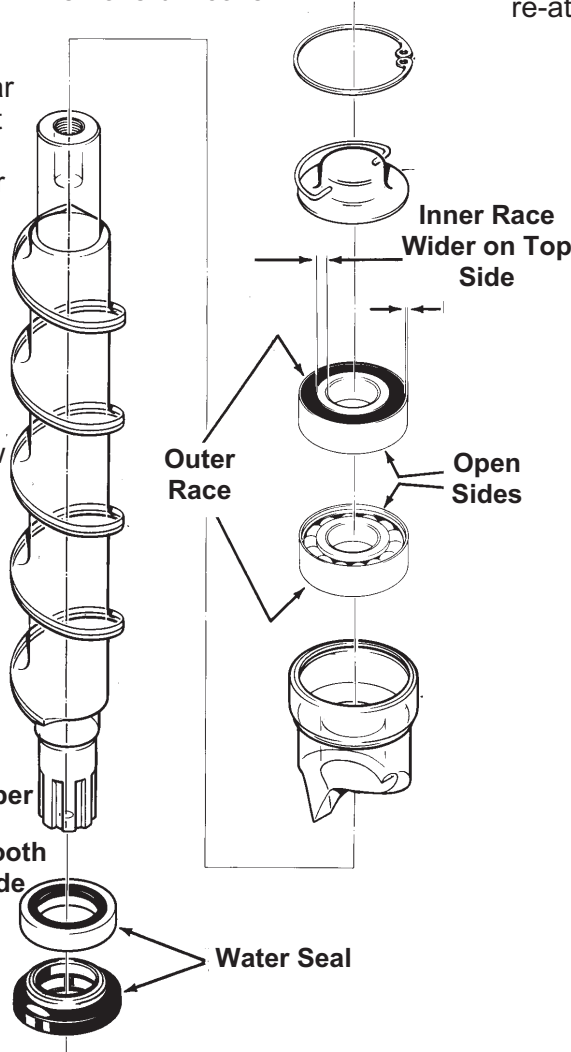

7. Attach the auger to the top bearing and breaker.

8. Return the auger to the evaporator and slide it down until the splines touch the coupling.

9. Rotate the auger until the coupling splines align with the auger.

10. Push the auger down, and rotate the breaker until the screw holes line up with the pilot holes in the evaporator.

11. When the auger is completely seated, reinstall the breaker screws.

12. Replace permagum and foam top.

13. Switch on the water supply.

14. Check bin cover for electrical grounds and switch on the electrical power.

15. Observe operation. The unit should make minimal noise while producing ice. Catch first 2 minutes of ice and discard it.

16. Replace the bin cover and all panels.

MDT3F & MDT4F

Inspection:

Photo-Electric Eyes

The photo electric eyes used to “see” the ice build up in the top of the bin cover must be clean to get a good “look” at the ice. If clouded by mineral scale, the eyes will cause the ice machine to shut off and stay off.

To clean the photo-electric eyes.

1. Remove the top panel.
2. Pull both of the photo-electric eyes out of their rubber grommets.
3. Wash both eyes with a clean cloth dipped in Scotsman Ice Machine Cleaner.
4. Wash the eyes off with clean water.
5. Replace the eyes in the grommets
6. Replace the top panel

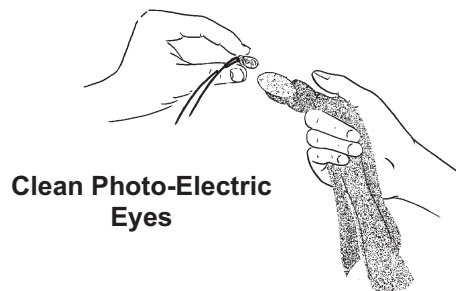

Water Level Sensor

The water level sensor may not shut the ice machine off when the reservoir goes dry if there is a film of mineral scale on the probe tip.

1. Remove the top panel.
 2. Remove the reservoir cover.
 3. Pull the water level probe up and out of the reservoir.
 4. Carefully wipe the tip of the probe with a clean cloth. Ice machine cleaner may be needed.
- Note: The tip is made of glass.
5. Reinsert the water level sensor in the reservoir.
 6. Replace the reservoir cover and the top panel.

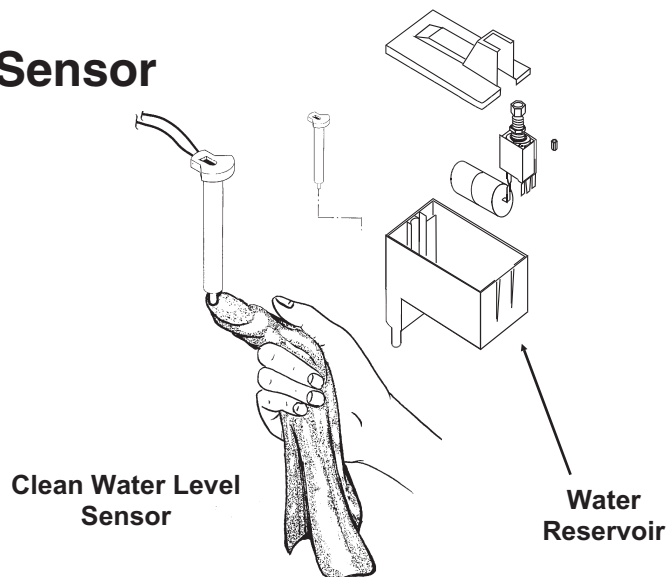

Coupling

Use the grease zerk on the side of the coupling to add grease once per year.

That concludes normal maintenance. If the fan motor has an oil plug, it may be oiled after 10 years of operation.

Service Diagnosis

PROBLEM	POSSIBLE CAUSE	PROBABLE CORRECTION
No ice is dispensed.	No ice in bin due to:	
	• No electrical power	Check/restore power
	• Overuse	Recheck ice needs vs. machine capacity.
	• Water supply turned off	Check water filter/hand valve/float valve
	• Bin controls dirty	Check & clean bin control (electric eyes)
	• Water sensor dirty	Check & clean water sensor
	• Control system malfunction	Check control system
	• Auger drive motor open	Check auger drive motor
	• Centrifugal switch open	Check centrifugal switch
	• Auger does not turn	Check coupling & gear reducer
	• No refrigeration	Check refrigeration system
	Ice in bin, but will not dispense:	
	Drive motor does not turn	
	• Vend system does not work	Check/replace vend system Check that cleaning switch has been released.
	• Dispense motor open	Check/replace dispense motor
	• Dispense output shaft broken	Check/replace output shaft
	Ice in bin, motor turns vane.	
	Ice jammed up	
	• Users held cup against dispense spout and jammed unit.	Advise owner/manager to instruct users.
	• Bin bottom slot not over spout	Check bin bottom position
• Ice will not slide down bin wall, bin out of round.	Check bin interior wall for rough texture or out of round.	
• Wet ice in the bin from high water level or high suction pressure	Check water level, check suction and discharge pressures	

MDT3F & MDT4F

Service Diagnosis

PROBLEM	POSSIBLE CAUSE	PROBABLE CORRECTION
Unusual noise	Mineral scale in evaporator	Clean water system with ice machine cleaner.
	Auger coupling dry	Grease coupling
	Auger coupling worn	Replace coupling and adapter stand.
	Bearings worn	Replace bearings and water seal.
	Gear motor loose on frame	Tighten bolts, check grommets
	Low water level	Check water level in reservoir
	Tubing vibrating	Check tubing for contact
	Tooth on a gear missing	Check gears in auger drive
	Compressor too loud	Replace compressor
	Gear noise	Check gear motor for oil leak
No water is dispensed	Water Switch in Off position	Switch to ON
	Water switch open	Replace switch
	Water solenoid plugged up	Clean inlet screen of solenoid
	Water solenoid coil open	Replace solenoid
	Vend system does not work	Check/replace vend system
	Water turned off	Restore water supply
Water drips from spout	Melting ice in chute	Some water dripping is normal
	Unit or bin not level	Level unit, check bin
	Water solenoid leaks thru	Replace solenoid
	Ice jammed in spout	Clear ice jam, check for cause
Ice will not stop dispensing	Vend system does not work	Check/replace vend system
Water leaks from cabinet	Evaporator water seal worn or cracked	Replace seal and bearings
	Tubing to evaporator leaks	Replace tubing/fittings
	Drain leaks	Check drain tubes and fittings
	External drain restricted	Clean out drain
No refrigeration	Gear motor does not turn	Check motor
	Centrifugal switch does not close	Check switch
	Fan motor does not turn	Check fan motor
	Lack of refrigerant	Add refrigerant, if problem is reduced, locate leak and repair it.
	Compressor does not pump	Check/replace start capacitor
Check/replace start relay		
Check/replace compressor		

SERVICE DIAGNOSIS: Circuit Board

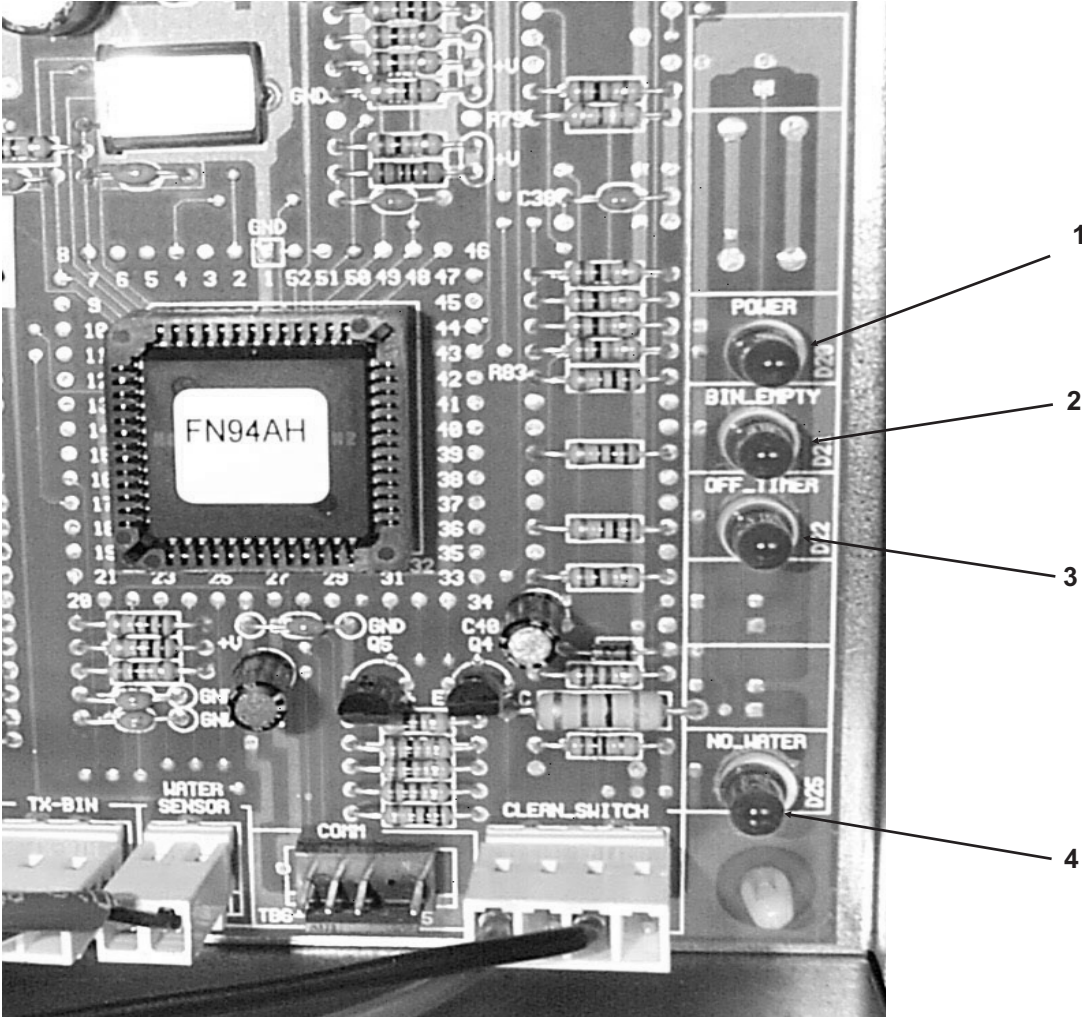

Explanation of Indicator Light	Position On Board	Name and Meaning of Light or Reset
On at all times when the master switch is ON and machine is connected to electrical power.	1	Power , ON = Normal
On when ice level is low (unit making ice).	2	Bin Empty , ON = Needs Ice
Normal 6 minute off/delay start. To prevent short cycling, the machine will not restart after any shut off (except power to the board) until 6 minutes have passed.	3	Off Timer , ON = Unit cycling off
On when water level is low in the reservoir.	4	No Water , ON = Trouble

To check the electrical system, first check the lights on the circuit board.

1. Remove the top panel.
2. Remove the left side panel.
3. Remove the control box cover.

MDT3F & MDT4F

Removal and Replacement

Panels:

1. Remove two screws at the back of the top panel.
2. Lift up at the back and push the top panel forward to release it.
3. Remove 3 screws at the top, 3 screws at the bottom and 1 screw at the front edge of each side panel.
4. Push each side panel to the rear to release the panel from the cabinet frame.

Dispensing System

The dispensing system consists of the vend switch, dispense motor, dispense vane, bin bottom and bin.

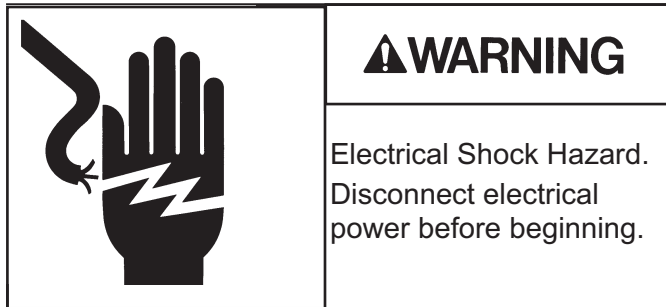

Dispense Gear Motor

1. Disconnect electrical power.
2. Remove top panel.
3. Remove one screw holding ground strap to cabinet frame.
4. Cut off two dispense motor wire nuts.
5. Remove screws holding dispense drive gear motor to the bin top.
6. Pull gear motor off the bin top.
7. Unscrew the output shaft extension from the gear motor.
8. Remove screws holding the mounting bracket to the gear motor.
9. Reverse to reassemble, be certain that the new wire nuts are secure and that the ground strap is reattached.

Dispense Vane

1. Disconnect electrical power.

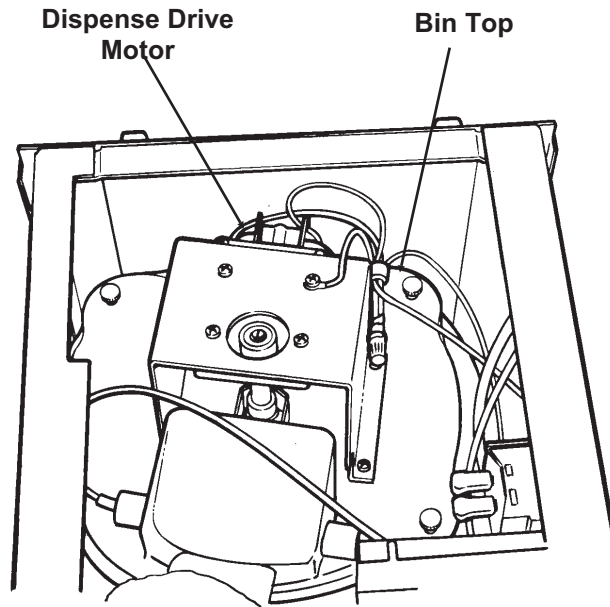

2. Remove top panel.
3. Remove four thumb screws holding bin cover to bin.
4. Lift bin cover off bin. Set aside.
5. Grasp the ice vane and pull it straight up.
6. Reverse to reassemble.

Bin Bottom.

Perform steps 1-5 above (to remove the dispense vane).

1. Lift bin bottom out of the dispense bin.
2. When replacing, be sure that the slot on the bin bottom is over the dispense chute (at the front).

Water System

The water system consists of the reservoir and inlet water valve.

Reservoir.

1. Shut off the water supply.
2. Remove the top panel.
3. Remove the right side panel.
4. Drain the water reservoir and evaporator.
5. Disconnect inlet and outlet tubes from the reservoir.
6. Remove screws holding reservoir to its mounting bracket.
7. Remove reservoir from the machine.
8. Reverse to reassemble.

Float Valve

1. Shut off the water supply.
2. Remove the top panel.
3. Remove the reservoir cover.
4. Remove the water inlet tube.
5. Push in the mounting tabs at the back of the reservoir and lift the valve out of the reservoir tank.
6. Replace with a new valve or replace the valve plunger.

Valve Plunger

1. After the valve has been removed from the reservoir, remove the nut holding the valve to its mounting bracket.
2. Pull out the cotter pin to release the internal valve plunger.

Note: Do not replace the plunger if the valve's seat is damaged. Replace the valve.

Inlet Water Valve.

1. Disconnect electrical power.
2. Shut off the water supply.
3. Remove the top panel.
4. Remove the right side panel.
5. Remove wire harness from inlet water valve.
6. Remove tube connecting outlet of the valve to the dispense tube.
7. Rotate the valve to unscrew it from its inlet fitting.
8. Reverse to reassemble.

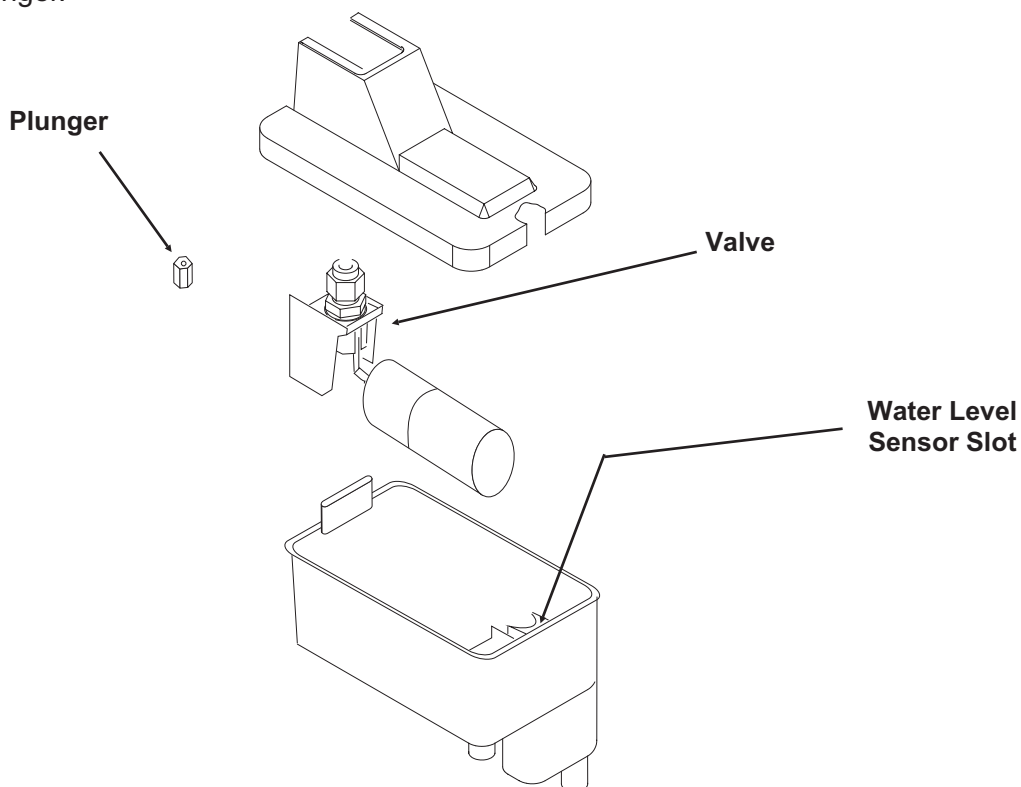

MDT3F & MDT4F

Bearings, Water Seal and Auger

1. Disconnect electrical power.

Rotating Parts Hazard Disconnect Electrical Power Before Beginning	CAUTION
---	----------------

2. Shut off the water supply.
3. Remove the top panel.
4. Remove the side panels.
5. Drain the reservoir and evaporator.
6. Remove foam cap from the top of the evaporator.
7. Remove the two permagum plugs from the side of the evaporator.
8. Pull up on the ring to lift the auger out of the evaporator.

If the auger will not lift out:

1. Remove snap ring holding bearing cover to breaker.
2. Remove bearing cover.
3. Unscrew bolt holding bearing to auger.
4. Thread in a threaded rod and weight or slide-hammer puller into the auger.
5. Use the threaded rod & weight or slide hammer puller to remove the auger.

Or

1. Remove three cap screws holding evaporator to the adapter stand.
2. Lift evaporator up slightly and tip the bottom out to expose the splined end of the auger.
3. Use a plastic mallet or dead-blow hammer to tap the bottom of the auger and force the auger up. Do NOT damage the splines of the auger or the auger will have to be replaced.

If the auger is "frozen" to the bottom bearing, do not force the bottom bearing thru the evaporator.

1. Remove three cap screws holding evaporator to the adapter stand.
2. Lift evaporator up slightly and tip the bottom out to expose the splined end of the auger.
3. Remove snap ring holding bearing cover to breaker.
4. Remove bearing cover.
5. Unscrew bolt holding bearing to auger.
6. Screw a length of threaded rod or a shoulder screw into the auger.
7. Tap on the end of the threaded rod to push the auger out of the bottom of the evaporator.
8. Replace the bearings and water seal. Replace the auger if the splines are damaged. Replace the evaporator if more than 1/3 of the vertical rifle grooves are gone. Sand or hone and sand the inside of the evaporator if mineral build up is heavy.

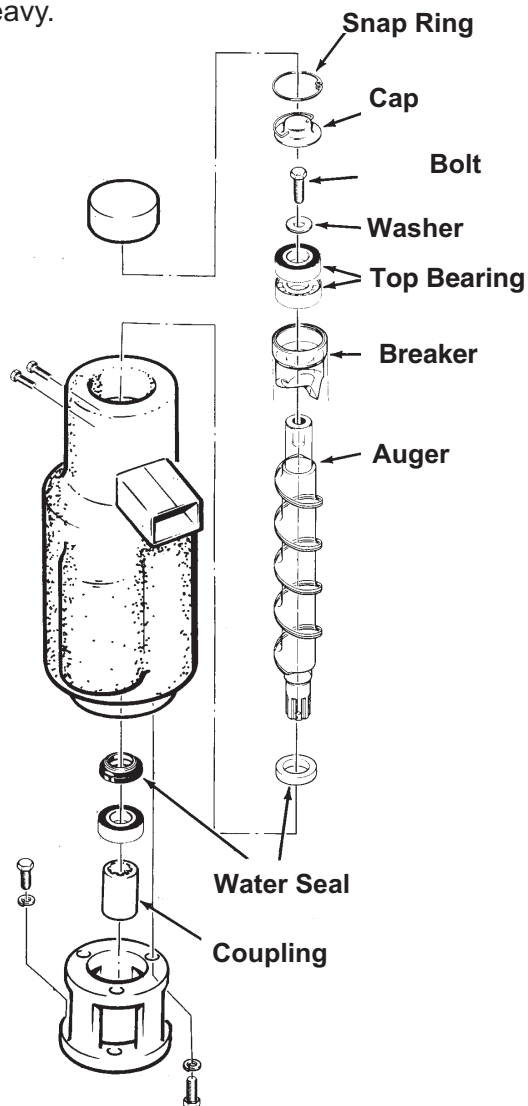

Bearing Replacement:

Top Bearing Replacement

If the inner race is secure, use an arbor press to push the top bearing out of the breaker. If the inner race has separated from the bearing, replace the breaker.

Insert a new bearing in the breaker, check for orientation:

The top of the bearing has a wider inner race and a narrower outer race than the bottom.

Replace the "O" ring in the breaker.
Push the bearing in, push only on the outer race.

Water Seal & Bottom Bearing Replacement:

1. Remove old rotating half from the auger. Clean the mounting area.

2. Place a bead of food grade sealant (such as Scotsman part number 19-0529-01) onto the shoulder of the auger where the rotating half of the water seal will be installed.

3. Wash the new seal in water. While wet, slip it onto the bottom of the auger, rubber side toward the auger. Push up until seated against the sealant. Do not allow any sealant to come into contact with the face of the seal.

4. Wash the stationary half the water seal with water. Slip it up into the bottom of the evaporator until the bottom of the seal is inside the evaporator about 1/4".

5. Push the bottom bearing against the water seal until the bottom bearing is inside the evaporator about 1/16".

6. Replace the evaporator on the adapter, and re-attach the stand using the original bolts.

7. Attach the auger to the top bearing and breaker.

8. Return the auger to the evaporator and slide it down until the splines touch the coupling.

9. Rotate the auger until the coupling splines align with the auger.

10. Push the auger down, and rotate the breaker until the screw holes line up with the pilot holes in the evaporator.

11. When the auger is completely seated, reinstall the breaker screws.

12. Replace permagum and foam top.

13. Switch on the water supply.

14. Check bin cover for electrical grounds and switch on the electrical power.

15. Observe operation. The unit should make minimal noise while producing ice. Catch first 2 minutes of ice and discard it.

16. Replace the bin cover and all panels.

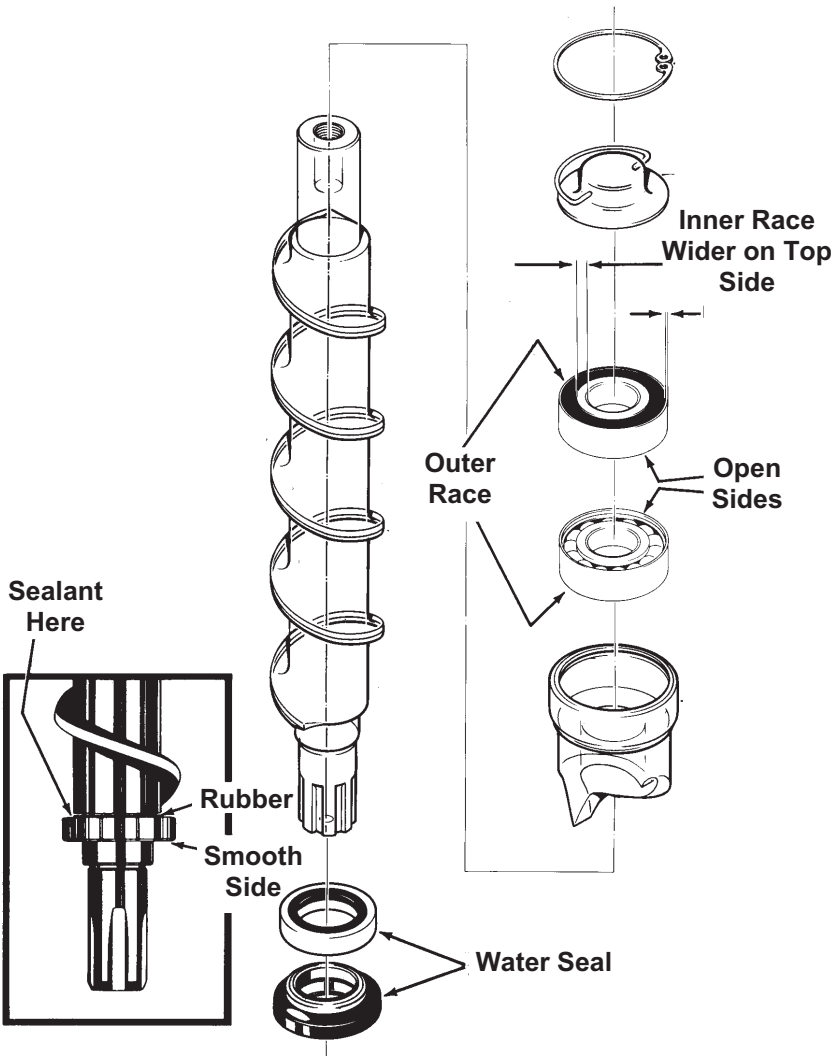

MDT3F & MDT4F

Refrigeration System

This ice machine uses R-134a as the refrigerant. This refrigerant has no chlorine, and therefore requires polyolester type refrigerant oil. This oil requires specific service procedures.

General Service

A HFC type liquid line drier is required. "Standard" driers may not take out enough moisture and may affect the oil additives.

The time that the refrigeration system is open to the air must not exceed 15 minutes. The oil will rapidly absorb moisture from the air, and the contact time must be kept to a minimum.

A special or very sensitive electronic leak detector will be needed to locate refrigerant leaks. Many are on the market that will sense R-134a.

The access valves must be in the closed position before the hose caps are removed. Do not remove the hose caps before checking the position of the valve. Use a 3/16" allen wrench to open and close the valve.

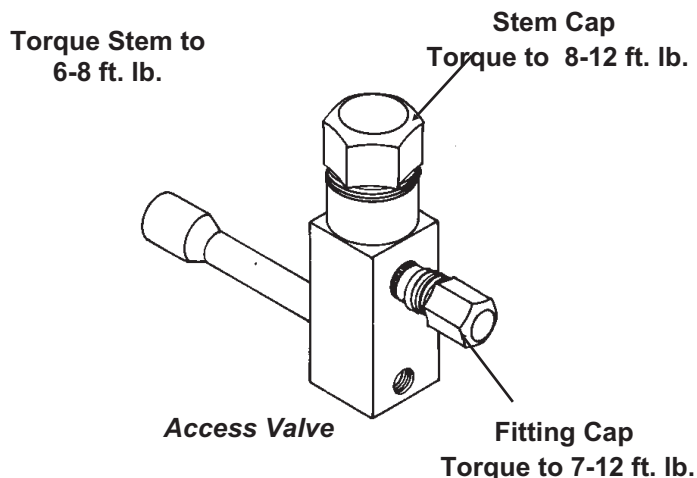

As with any other refrigerant, do not place pressurized air or oxygen into the refrigeration system.

Note: The refrigeration system uses an HFC type refrigerant and MUST use an HFC type drier.

Evacuation to 300 microns is recommended.

Temperature in °F.	PSIG of R-134a
-10	2.0
-6	3.7
-4	4.6
-2	5.5
0	6.5
1	7.0
2	7.5
3	8.0
4	8.6
5	9.1
10	12.0
12	13.2
14	14.4
16	15.7
18	17.1
20	18.4
25	22.1
30	26.1
31	26.9
32	27.8
33	28.6
34	29.5
35	30.4
40	35.0
45	40.0
50	45.4
75	78.7
90	104.3
110	146.4
120	171.1
130	198.7
150	262.8

Gear Reducer Removal

1. Disconnect electrical power.

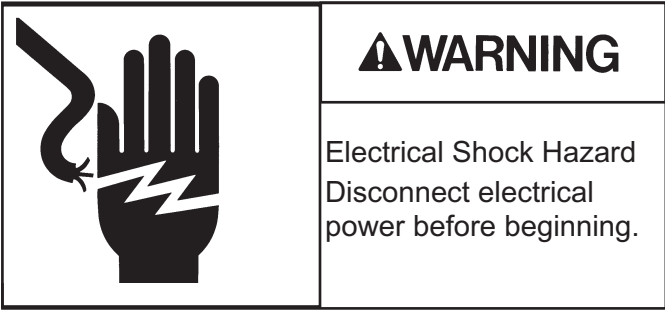

- 2. Shut off the water supply.
- 3. Remove the top and side panels.
- 4. Remove the control box cover.
- 5. Remove the centrifugal switch cover on the top of the auger drive motor.
- 6. Disconnect the electrical wires from the centrifugal switch.
- 7. Drain the evaporator and reservoir.

- 8. Disconnect the water inlet tube from the evaporator.
 - 9. Remove the three screws holding the evaporator to the adapter stand.
 - 10. Lift the evaporator up high enough for the auger to clear the adapter stand.
 - 11. Remove the mounting bolts holding the gear reducer to the cabinet frame.
 - 12. Trace auger drive motor wires back to the control box.
 - 13. Disconnect the drive motor wires from the relay on the circuit board.
 - 14. Pull the wires back to the auger drive motor.
 - 15. Pull the gear reducer out the side of the cabinet to remove it from the machine.
- Note: If there is evidence of water near the output shaft of the gear reducer, it would be a wise precaution to pull the auger from the evaporator and check the bearings.
- 16. Rebuild or replace the gear reducer.

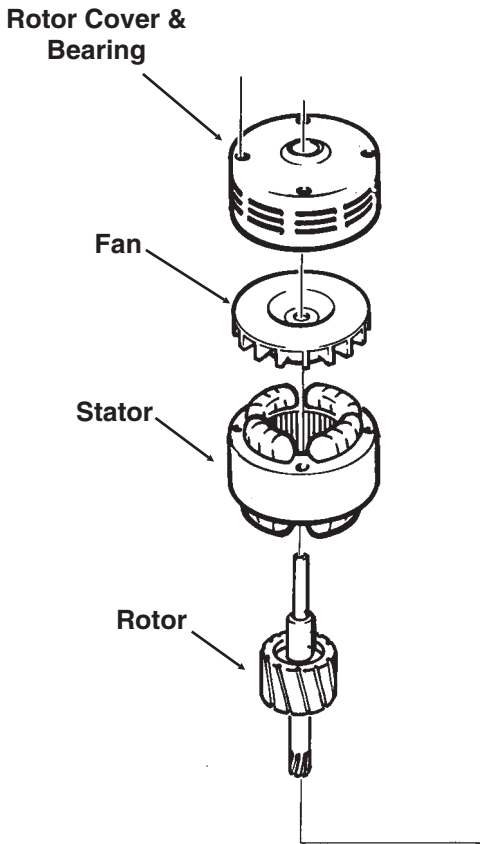

Gear Reducer Components

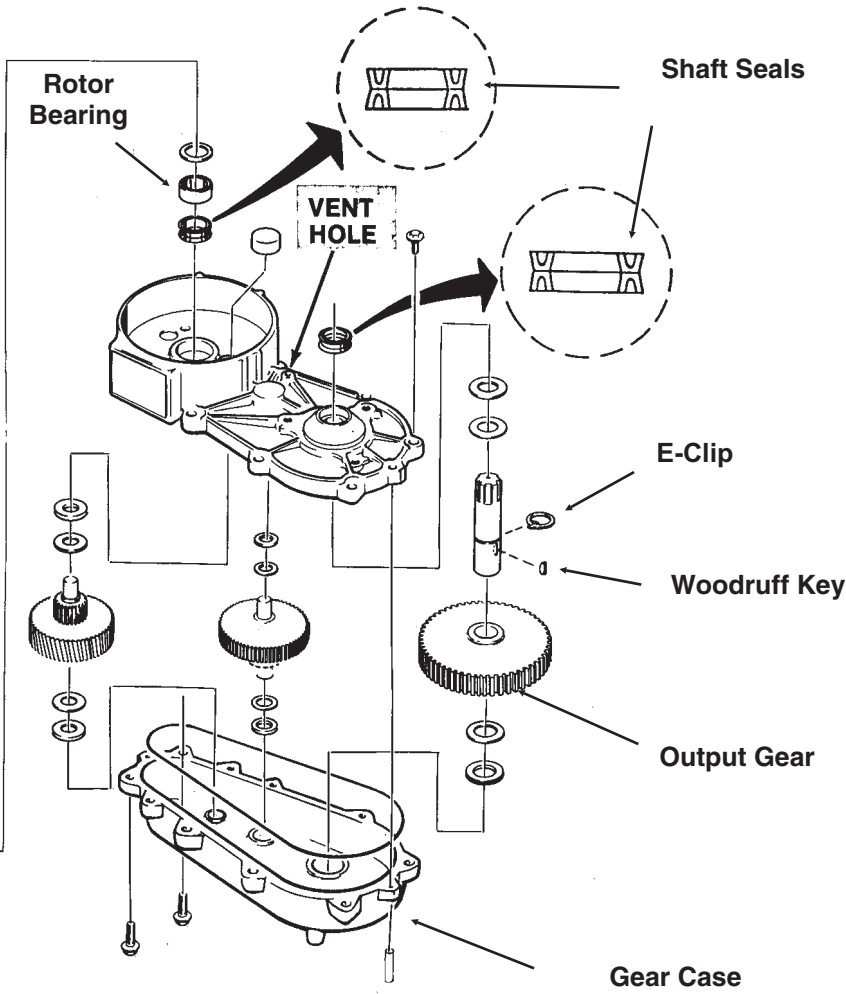

MDT3F & MDT4F

Auger Drive Motor

The windings or top bearing & cover may be replaced without removing the evaporator or gear reducer from the machine.

1. Disconnect electrical power.

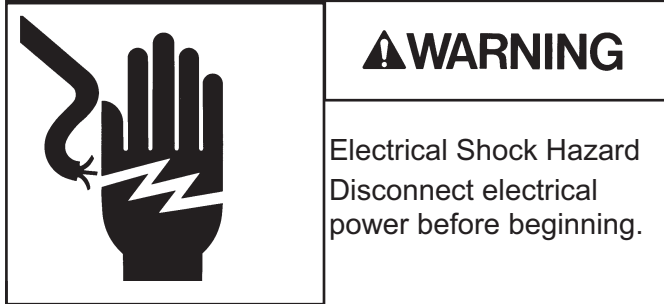

2. Shut off water supply.
3. Remove top panel.
4. Remove right side panel.
5. Drain the reservoir and evaporator.
6. Disconnect the reservoir outlet tube from the bottom of the reservoir.
7. Remove screws holding reservoir mounting bracket to the cabinet.
8. Lift the reservoir up & away from the top of the auger drive motor.
9. Remove the 4 bolts holding the auger motor cover to the gear reducer case.
10. Lift the plastic switch housing off the auger drive motor.
11. Hold the centrifugal switch and remove the screw holding it to the rotor of the motor.
12. Lift the centrifugal switch up and off the motor.
13. Lift the motor cover up and off the motor.
14. Pull the fan up and off the rotor.

If the windings are to be replaced, remove the left side panel and control box cover.

1. Locate the auger drive motor wires plugged into a relay on the circuit board.
2. Disconnect the auger motor's wires and pull them back to the auger drive motor.
3. Lift the auger motor windings off the gear reducer.

If the rotor needs to be removed:

1. Run a screw into the top of the rotor.
2. Grasp the screw with a grip pliers.
3. Pull and/or tap on the pliers to pull the rotor & bearing out of the gear reducer.
4. Inspect the bearing and input seal. Replace them if worn.

Note: When the rotor is re-installed, be certain that the bearing is fully seated in the gear case.

Gear Reducer Rebuild

1. After the gear reducer has been removed, the internal components may be inspected and/or replaced. Remove all bolts holding the two case halves together.
 2. Tap against the roll pins at each end of the gear cases to split them.
 3. Pry the case halves apart.
 4. Check the internal condition of the gear reducer. If rusty or water is present, replace the complete assembly. The oil should be black and the proper oil level is 1/8" from the top of the biggest gear (with all gears installed). Check the input seal.
- The gears may be replaced individually.

MDT3 and MDT4 Service Parts

This parts lists contains part numbers for the service parts available for the MDT3 and MDT4. They have been manufactured in both 60 Hz and 50 Hz models.

The 60 Hz models are:

- MDT3F12-1A
- MDT4F12-1A

The 50 Hz models are:

- MDT3F12-6A
- MDT4F12-6A

Always check the model number of the ice machine being serviced to be certain that the parts ordered will be correct.

Table of Contents

Cabinet	Page 2
Condensing Components	Page 3
Evaporator, Auger, Bearings & Water Seal	Page 4
Water And Drain System	Page 5
Bin Cover, Dispenser Motor, Electric Eyes	Page 6
Prior Gear Reducer and Motor - A31977 type	Page 7
Gear Reducer 02-4399-21 or 02-4399-24 or 02-4398-21	Page 8
Control Box	Page 9
MDT4 60 Hz Wiring Diagram	Page 10
MDT3 Wiring Diagram	Page 11
Schematic Diagram	Page 12
MDT4 50 Hz	Page 13

MDT3 and MDT4 Service Parts

Cabinet

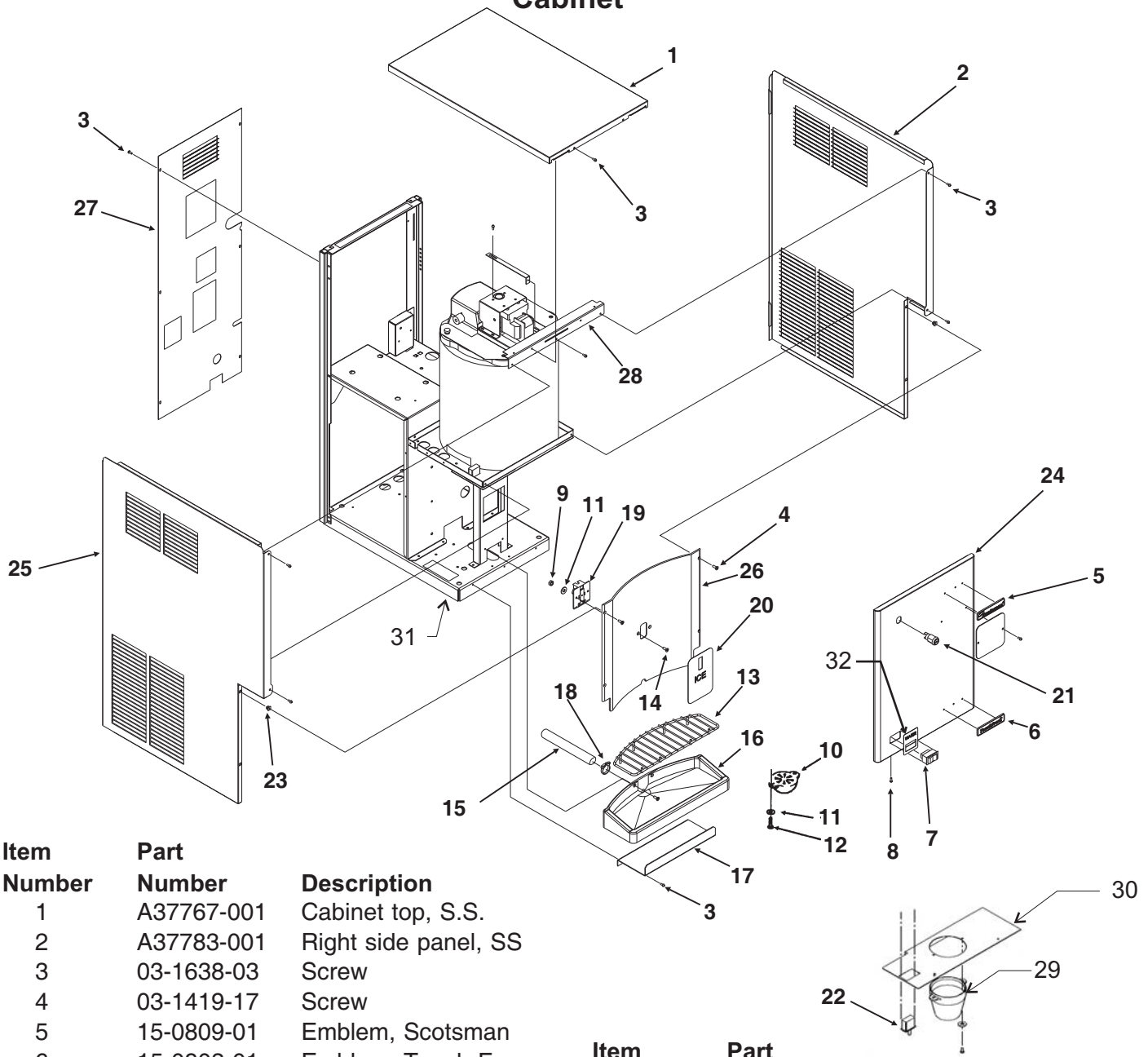

Item Number	Part Number	Description
1	A37767-001	Cabinet top, S.S.
2	A37783-001	Right side panel, SS
3	03-1638-03	Screw
4	03-1419-17	Screw
5	15-0809-01	Emblem, Scotsman
6	15-0803-01	Emblem, Touch-Free
7	12-1377-00	Switch
8	03-1403-15	Screw
9	03-1406-04	Nut
10	02-3944-01	Spout
11	03-1407-03	Washer
12	03-1403-19	Screw
13	02-3302-02	Grill
14	03-1418-30	Machine screw
15	13-0674-07	Tube, order 3 units.
16	02-3402-32	Sink - grey
17	A35875-015	Bracket
18	02-2814-10	Hose clamp
19	12-2551-20	Touch free sensor
20	17-2830-01	Decal

Item Number	Part Number	Description
21	12-2391-01	Lock, Gov't units only
22	12-2501-01	Touch Free disable switch
23	03-3804-01	Screw receptacle
24	A37766-021	Front panel, incl # 5,6,32
	A37766-002	Front panel, Gov't units
25	A37784-001	Left side panel, SS
26	02-3878-31	Splash panel - grey
27	A37875-001	Back panel
28	A37873-001	Support bracket
29	02-3944-01	Clear spout, replaced item 10 in May 2002
30	A36547-001	Mounting plate for spout
31	13-0566-01	Bottom gasket - complete
32	17-2831-01	Water decal

MDT3 and MDT4 Service Parts

Condensing Components

MDT4F12

Item Number	Part Number	Description
1	18-8741-21	60 Hz compressor
	18-8741-26	50 Hz compressor
2	18-8741-27	Overload for 60 Hz
	18-8741-22	Overload for 50 Hz
	18-8741-28	60 Hz relay
	18-8741-23	50 hz relay
3	18-8741-29	Start capacitor for 60 Hz
	18-8741-24	Start capacitor for 50 Hz
4	18-8849-01	60 Hz fan motor
	18-7200-03	50 Hz fan motor
5	18-8858-01	Fan blade for 60 Hz
	18-8743-01	Fan blade for 50 hz
6	A37839-001	Fan shroud for 60 Hz
	A36094-001	Fan shroud for 50 Hz
7	03-1405-40	Screw
7a	03-1407-02	Washer
7b	18-4700-28	Grommet
8	18-0108-41	Sleeve
9	16-0832-21	Access valve
9a	16-0832-03	Core cap
9b	16-0832-02	Stem cap
10	18-0422-00	Fan motor bracket
11	18-8846-01	Condenser
12	02-3319-01	Drier

MDT3F12

Item Number	Part Number	Description
1	18-8853-21	60 Hz compressor
	18-8853-26	50 Hz compressor
2	18-8853-27	Overload for 60 Hz
	18-8853-22	Overload for 50 Hz
	18-8853-28	60 Hz relay
	18-8853-23	50 hz relay
3	not used	
4	12-1681-23	60 Hz fan motor
	12-1681-04	50 Hz fan motor
5	18-8851-01	Fan blade
6	A37813-001	Fan shroud

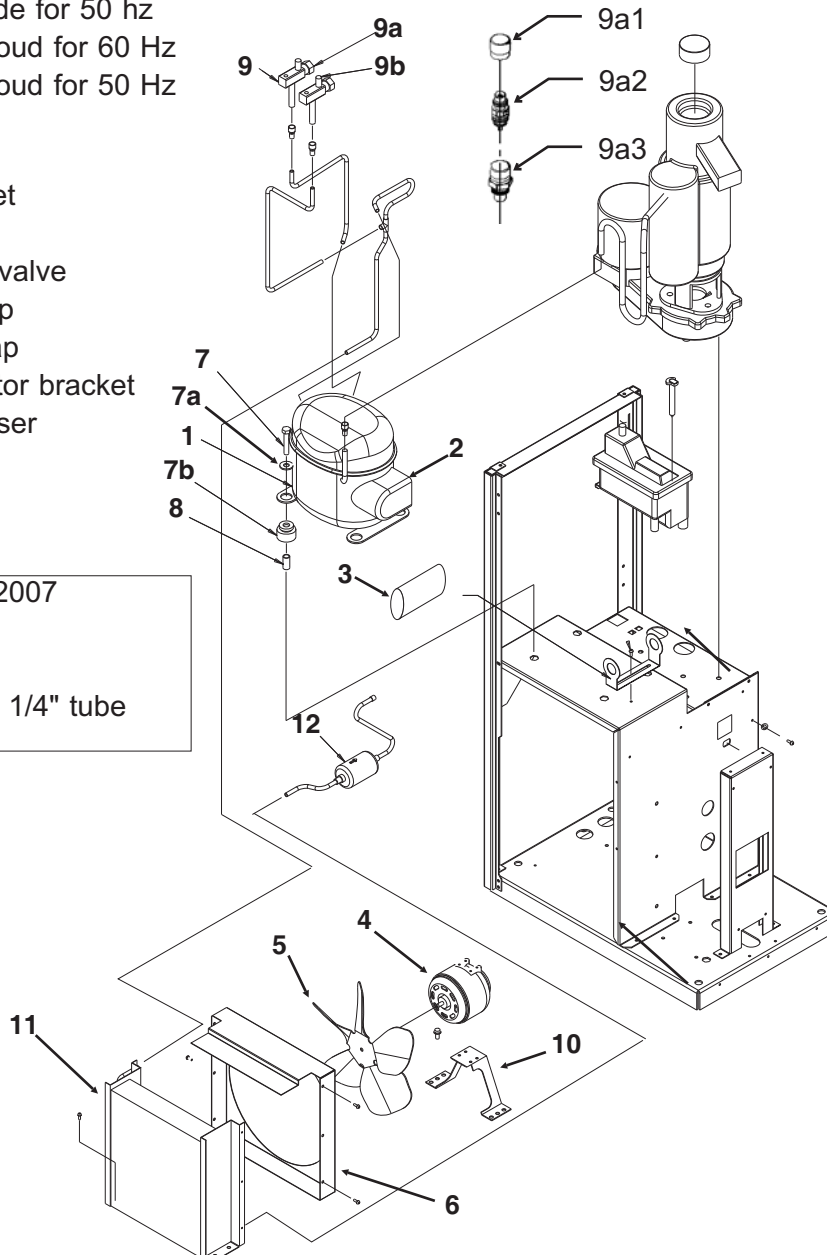

Access Valve Change - November 2007

9a1	16-1140-01	Cap
9a2	16-1139-01	Core
9a3	16-1138-01	Seat for 1/4" tube

MDT3 and MDT4 Service Parts

Evaporator, Auger, Bearings & Water Seal

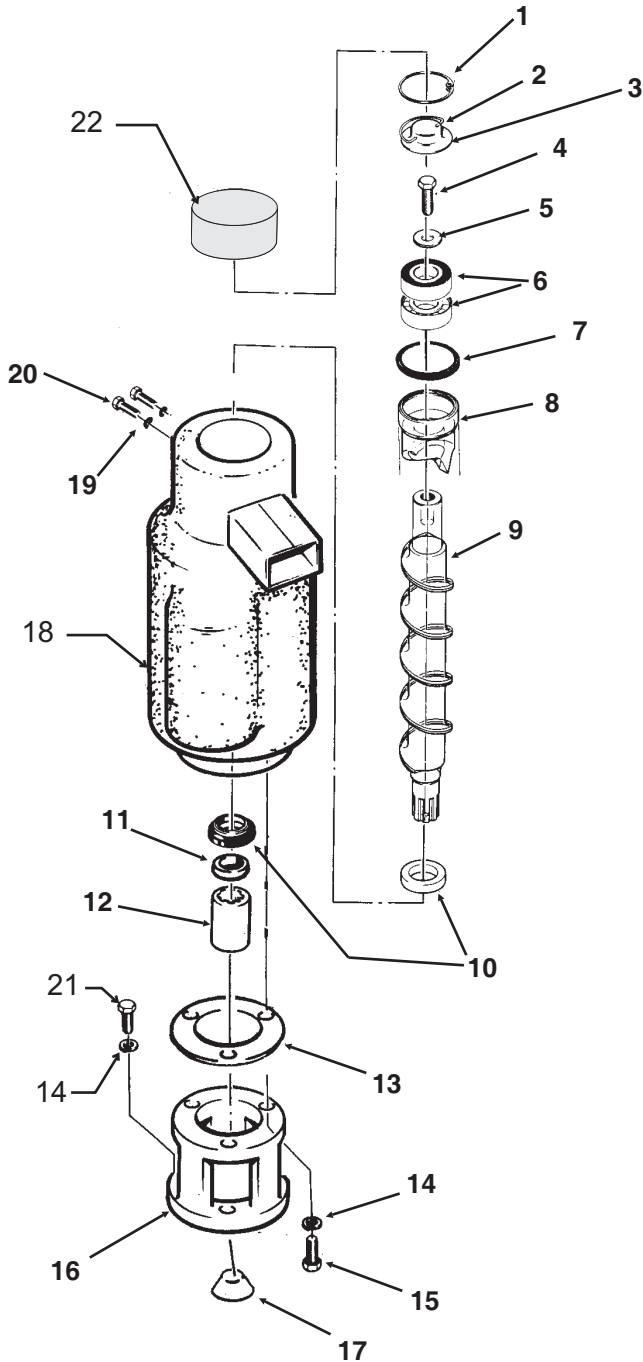

Item Number	Part Number	Description
1	03-1558-03	Retainer Ring
2*	A08162-000	Cap hook
3*	A07701-000	Cap
4	03-0758-00	Screw
5	A07699-000	Washer
6	02-1412-20	Top bearing set
7	13-0617-16	"O" ring
8	A14591-020	Breaker with bearing
9	02-4023-20	Auger
10	02-1300-01	Water seal
11	02-0417-20	Bottom bearing
12	A29915-002	Coupling
13	03-1505-00	Gasket
14	03-1410-04	Washer
15	03-1420-01	Cap screw
16	08-0595-01	Adapter
17	13-0941-01	Rubber drip shield
18	A36081-020	Evaporator
19	03-1417-07	Washer
20	03-1403-46	Screw
21	03-1405-38	Cap screw
22	02-4404-01	Threaded cap

* Not used after 04/07.

MDT3 and MDT4 Service Parts

Water And Drain System

Item Number	Part Number	Description
1	A37893-001	Vane Assembly
2	A38272-001	Bin Bottom Assy
3	02-3033-01	Hub Assembly
4	03-1409-22	Fiber Washer
5	A36118-020	Storage Bin
6	13-0895-01	Inlet water line requires 26"
7	03-1394-00	Pal Nut
8	12-1434-04	Water valve (60 Hz)
	12-1434-05	Water valve (50 Hz)
9	16-0869-01	Barbed adapter
10	02-4200-01	Preformed tube
11	A33101-022	Water sensor
12	02-3402-32	Sink
13	02-3302-02	Grill for sink
14	13-0674-07	Tube, requires 12"
15	02-2814-10	Clamps
16	13-0674-09	Tube, overflow to drain, requires 12"
16a		Bin drain, 11"
16b		Drain, 9"
17	02-2814-08	Clamp
18	02-2814-07	Clamp
19	02-3371-01	Reservoir Assy
20	A36402-001	Reservoir Bracket
21	02-3371-02	Float and arm
21a	02-3266-03	Plunger/seat
22	03-1407-05	Plain Washer
23	03-1645-01	Hex Cap Screw
24	13-0674-06	Tube (to evap.)
25	A21433-000	Inlet fitting
26	16-0870-01	NPT to compr. fitting
27	16-0871-01	Brass insert
28	16-0670-01	Tee

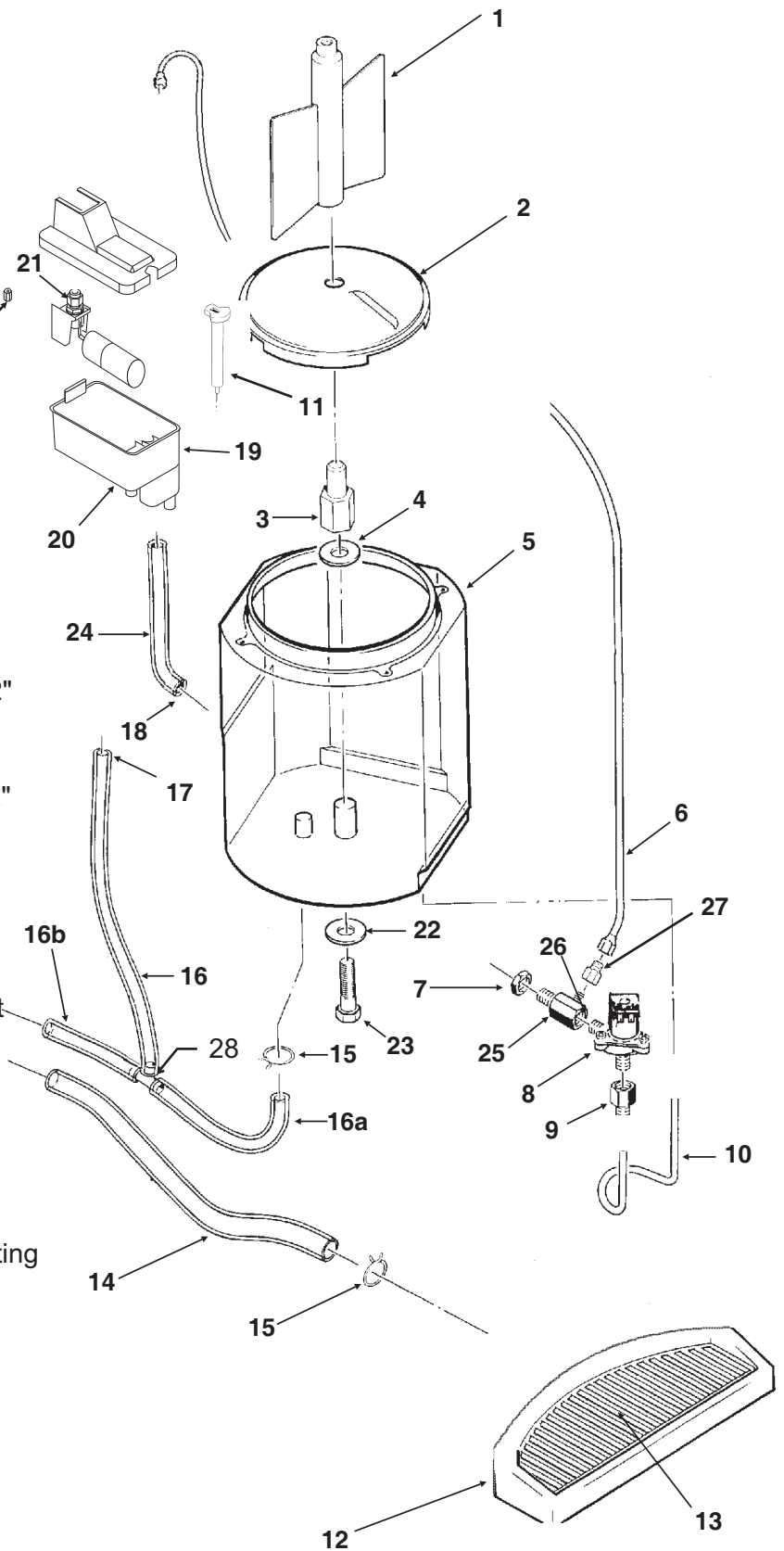

MDT3 and MDT4 Service Parts

Bin Cover, Dispenser Motor, Electric Eyes

Item Number	Part Number	Description
1	03-1403-15	Screw
2	03-1531-01	Screw
3	A35474-001	Motor Mtg. Bracket
4	02-3238-01	Bushing
5	03-0727-10	Thumbscrew
6	13-0866-01	Grommet
7	A37710-021	Electric eye set
8	02-3237-01	Bin top
9	02-3239-01	Nut
10	02-3241-01	Shaft
11	12-1610-01	Motor & gears 60 Hz
	12-1610-06	Motor & gears 50 Hz
12	02-1801-02	Strap
	A35483-021	Complete assembly 60 Hz (except items 5 and 7)
	A35483-026	Complete assembly 50 Hz (except items 5 and 7)

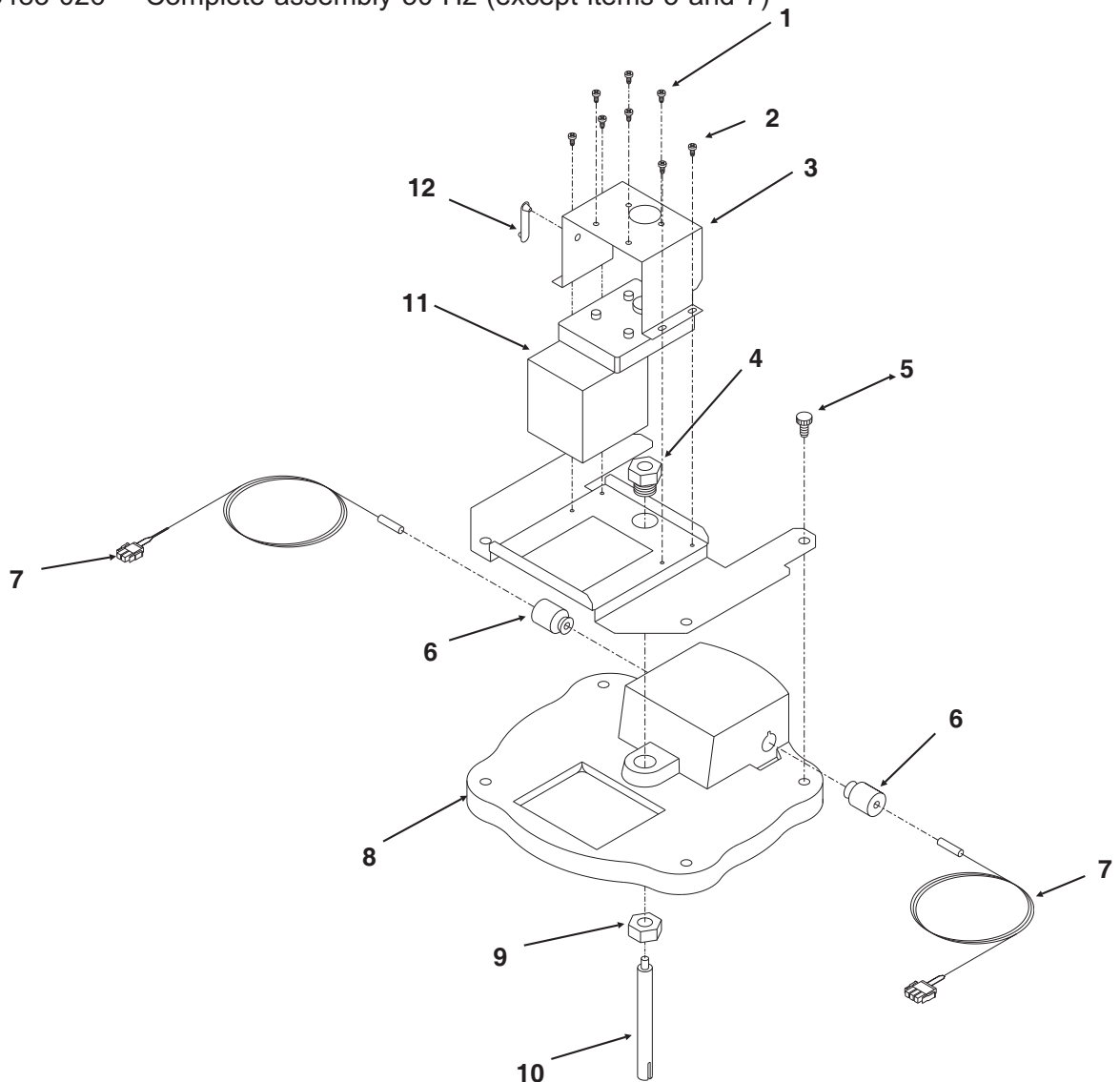

MDT3 and MDT4 Service Parts

Prior Gear Reducer and Motor - A31977 type

Item Number	Part Number	Description
1.	12-2059-01	Switch
2.	none, part of item 3	
3.	A27494-001	Centrifugal Sw. Kit
4.	03-1403-77	Screw
5.	A30579-001	Shaft and Actuator
6.	03-1408-36	Washer
7.	02-1503-00	Grease seal
8.	03-1408-21	Washer
9.	03-1408-04	Washer
10.	02-2445-01	Output shaft
11.	03-1515-03	Retaining ring
12.	03-1602-01	Woodruff Key
13.	02-2444-01	Output gear
14.	02-1505-00	O-ring
15.	03-0774-11	Roll pin
16.	A28166-001	Gear Case
17.	03-1408-39	Washer
18.	03-1408-40	Washer shim
19.	02-2439-01	2nd gear & third pinion
20.	03-1408-41	Washer
21.	03-1408-38	Washer
22.	02-2438-01	1st gear & 2nd pinion
23.	A28165-021	Gear box cover
24.	02-3969-20	Grease seal
25.	02-1501-00	Bearing

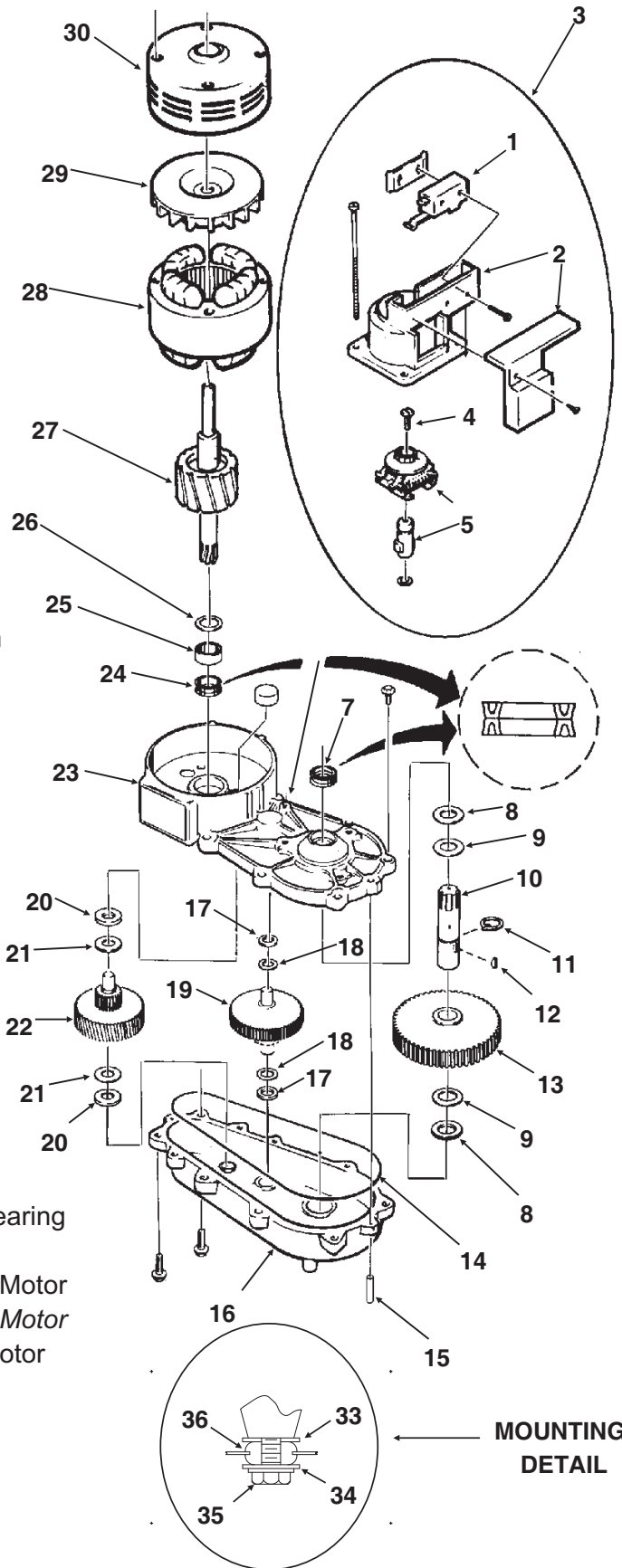

26.	03-1408-08	Washer
27.	A37707-021	60 Hz motor kit*
28.	A38501-001	50 Hz motor kit*
29.	A28168-001	Fan
30.	A38487-001	Motor Housing with bearing
31.	A32379-027	Oil
32.	02-4399-21	Complete 60 Hz Gear Motor
	02-4399-24	Complete 50 Hz Gear Motor
	02-4398-21	Gear reducer kit, no motor
33.	A24295-001	Spacer
34.	03-1408-02	Washer
35.	03-1405-45	Screw
36.	13-0639-00	Grommet

* motor kit includes items 25, 26, 29 and 30.

MDT3 and MDT4 Service Parts

Gear Reducer 02-4399-21 or 02-4399-24 or 02-4398-21

ITEM NUMBER	PART NUMBER	DESCRIPTION
1.	12-2059-01	Switch
2.	A27494-001	Centrifugal Sw. Kit
3.	03-1403-77	Screw
4.	A30579-001	Shaft and Actuator
5.	part of item 2	
6.	03-1408-36	Washer
7.	02-1503-00	Grease seal
8.	13-0947-01	Gasket
9.	03-1408-39	Washer
10.	03-1408-40	Washer shim
11.	02-2439-01	2nd gear and third pinion
12.	03-1408-41	Washer
13.	03-1408-38	Washer
14.	02-2438-01	1st gear & second pinion
15.	02-3969-20	Grease seal
16.	02-1501-00	Bearing
17.	03-1408-08	Washer
18.	A37707-021	60 Hz motor kit*
	A38501-001	50 Hz motor kit*
19.	A28168-001	Fan
20.	A38487-001	Motor Housing w/ bearing
21.	A32379-027	Oil
22.	02-4399-21	Complete 60 Hz Gear Motor Assembly with motor
	02-4399-24	Complete 50 Hz Gear Motor Assembly with motor
	02-4398-21	Gear reducer kit, no motor
23.	A24295-001	Spacer
24.	03-1408-02	Washer
25.	03-1405-45	Screw
26.	13-0639-00	Grommet

* motor kit includes items 16, 17, 19, 20
 Note: Wire termination on replacement motor varies from original equipment.

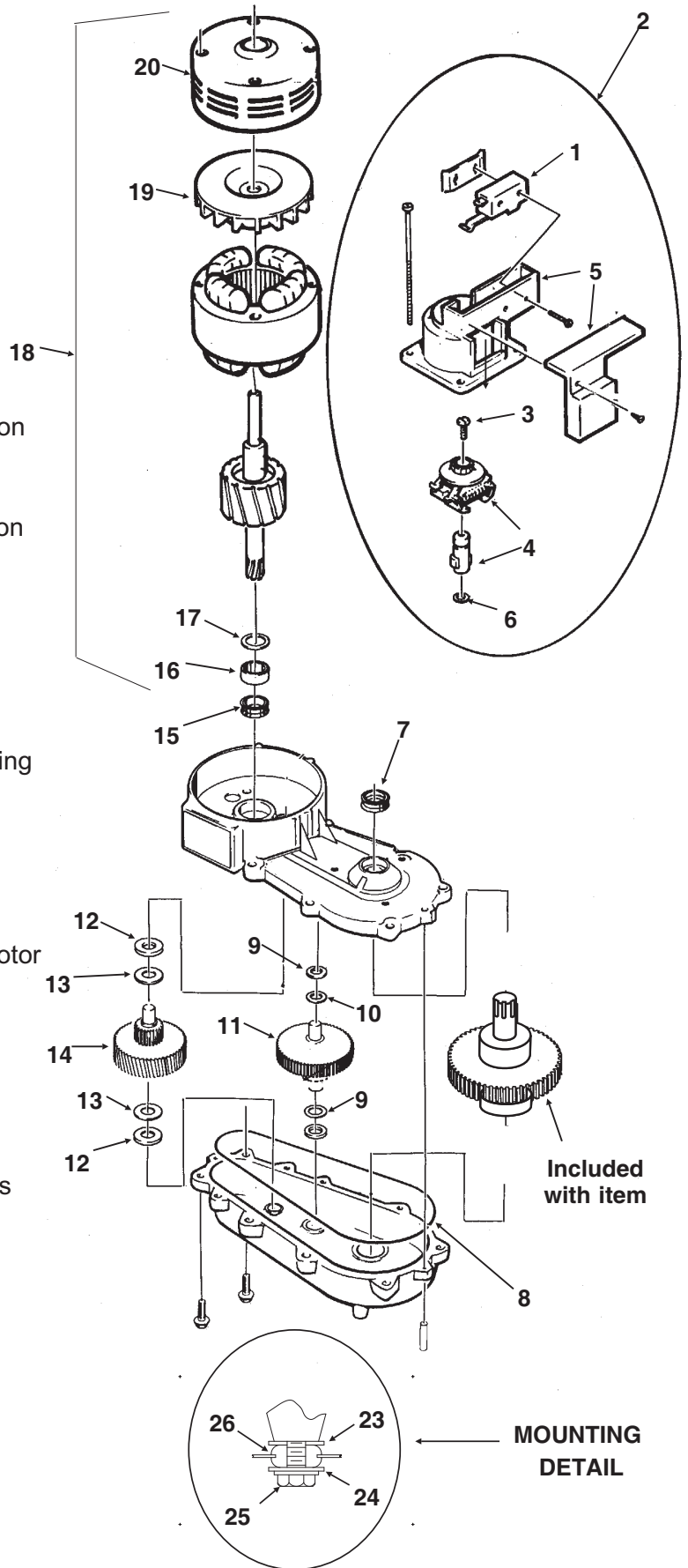

MDT3 and MDT4 Service Parts Control Box

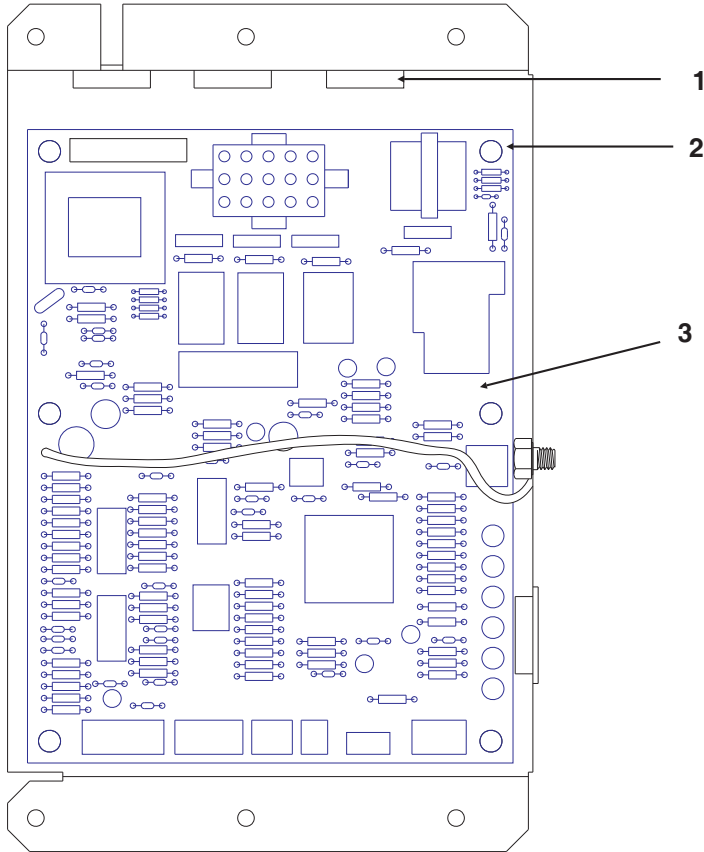

Item Number	Part Number	Description
1	12-1213-10	Snap bushing
2	12-2499-01	Stand off
3	12-2843-21	Circuit board for 115/60/1
	12-2843-26	Circuit board for 220/50/1

MDT3 and MDT4 Service Parts

MDT4 60 Hz Wiring Diagram

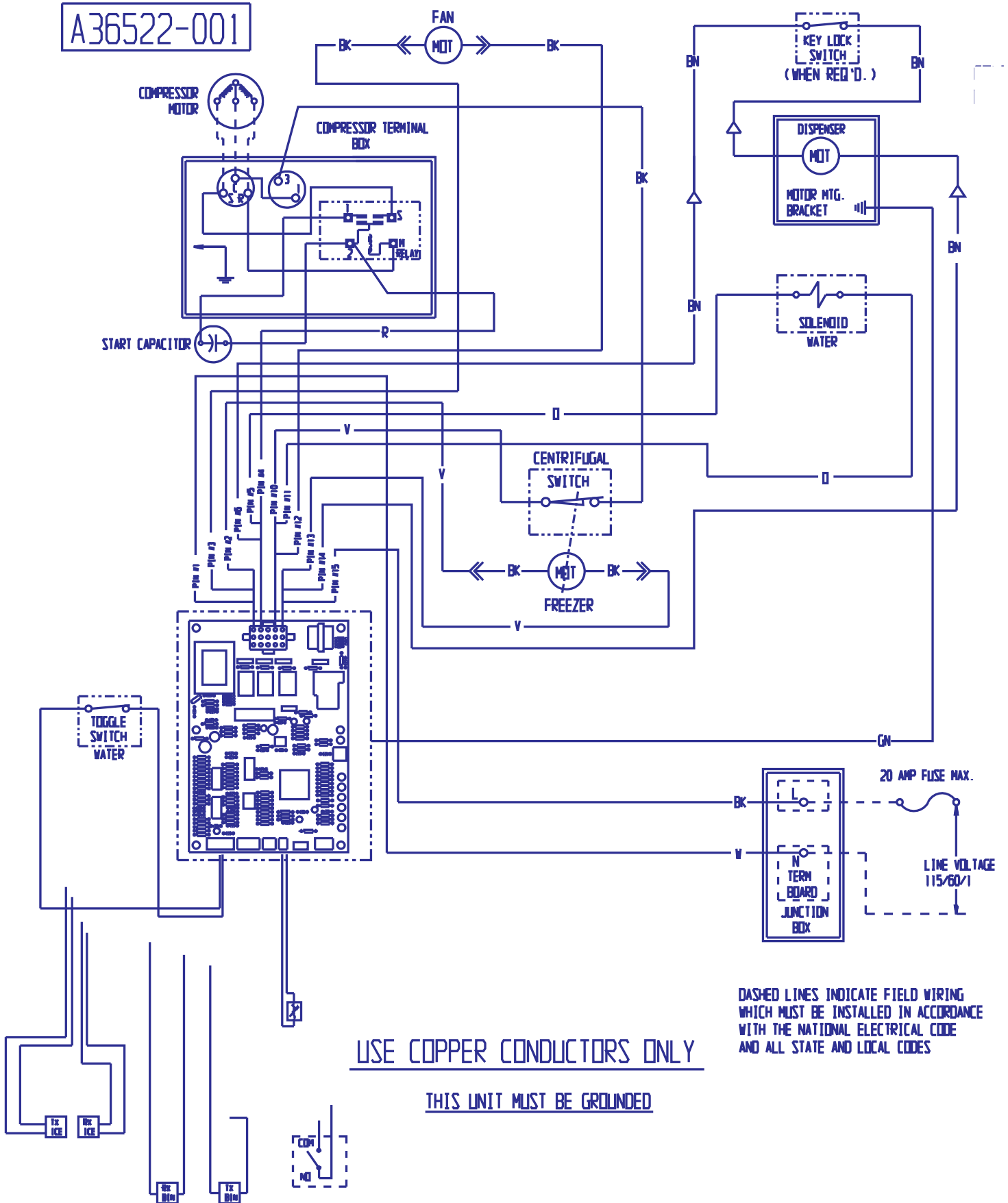

A36522-001

USE COPPER CONDUCTORS ONLY

THIS UNIT MUST BE GROUNDED

DASHED LINES INDICATE FIELD WIRING WHICH MUST BE INSTALLED IN ACCORDANCE WITH THE NATIONAL ELECTRICAL CODE AND ALL STATE AND LOCAL CODES

MDT3 and MDT4 Service Parts

MDT3 Wiring Diagram

17-2835-01

△ = WIRE NUT

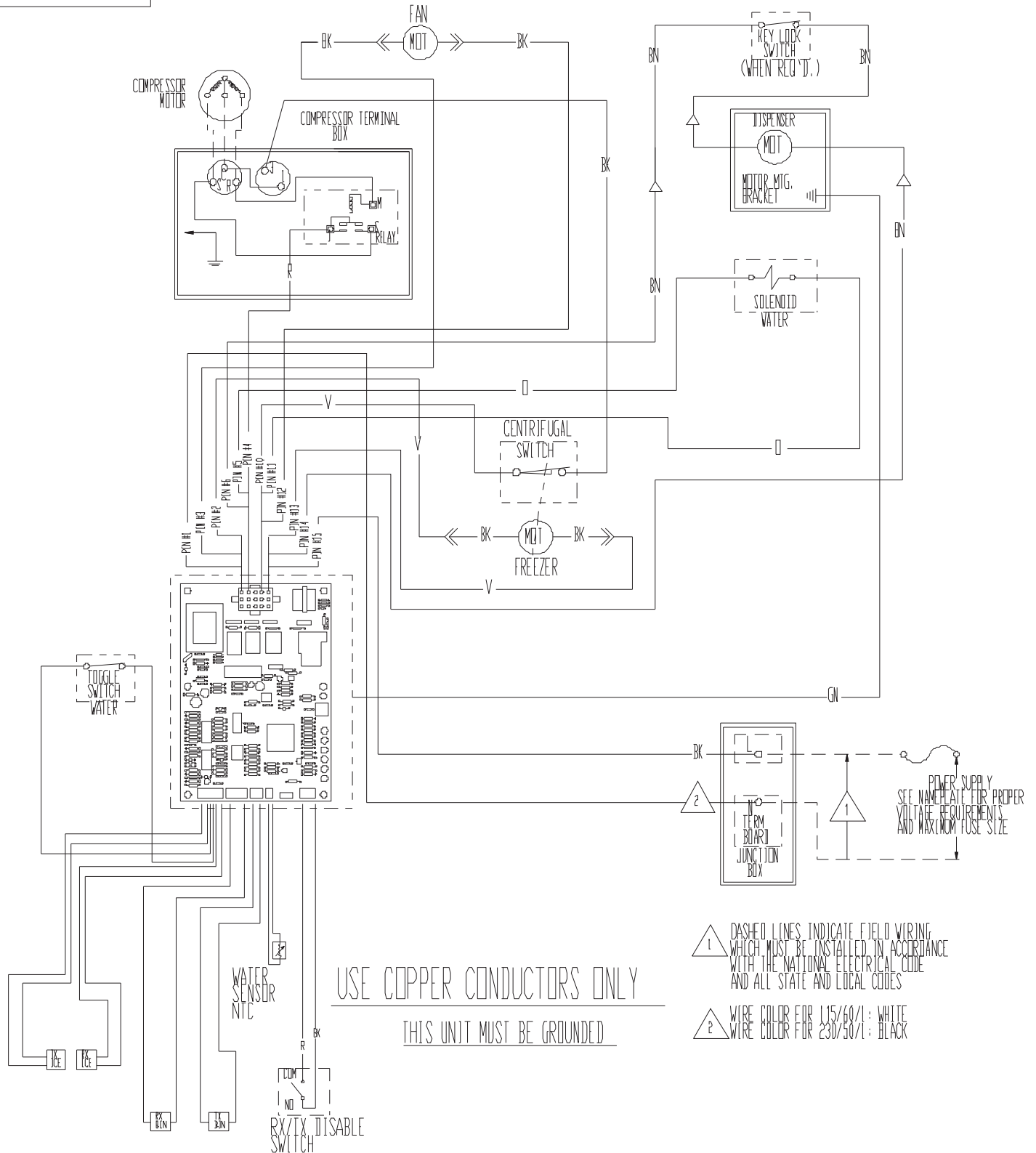

MDT3 and MDT4 Service Parts Schematic Diagram

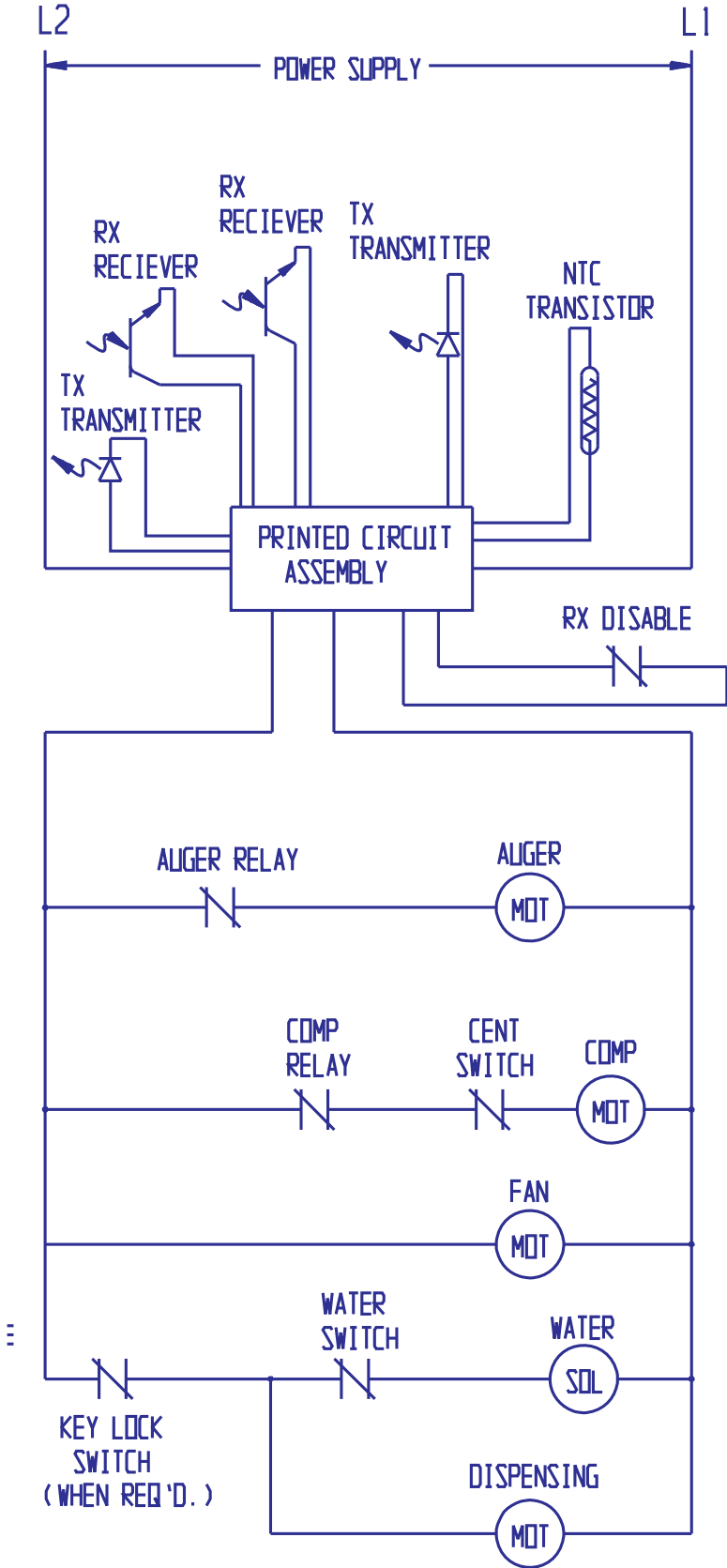

Controls shown in the ice making mode with all dispensing systems in operation.

MDT3 and MDT4 Service Parts

Wiring Diagram MDT4 50 Hz

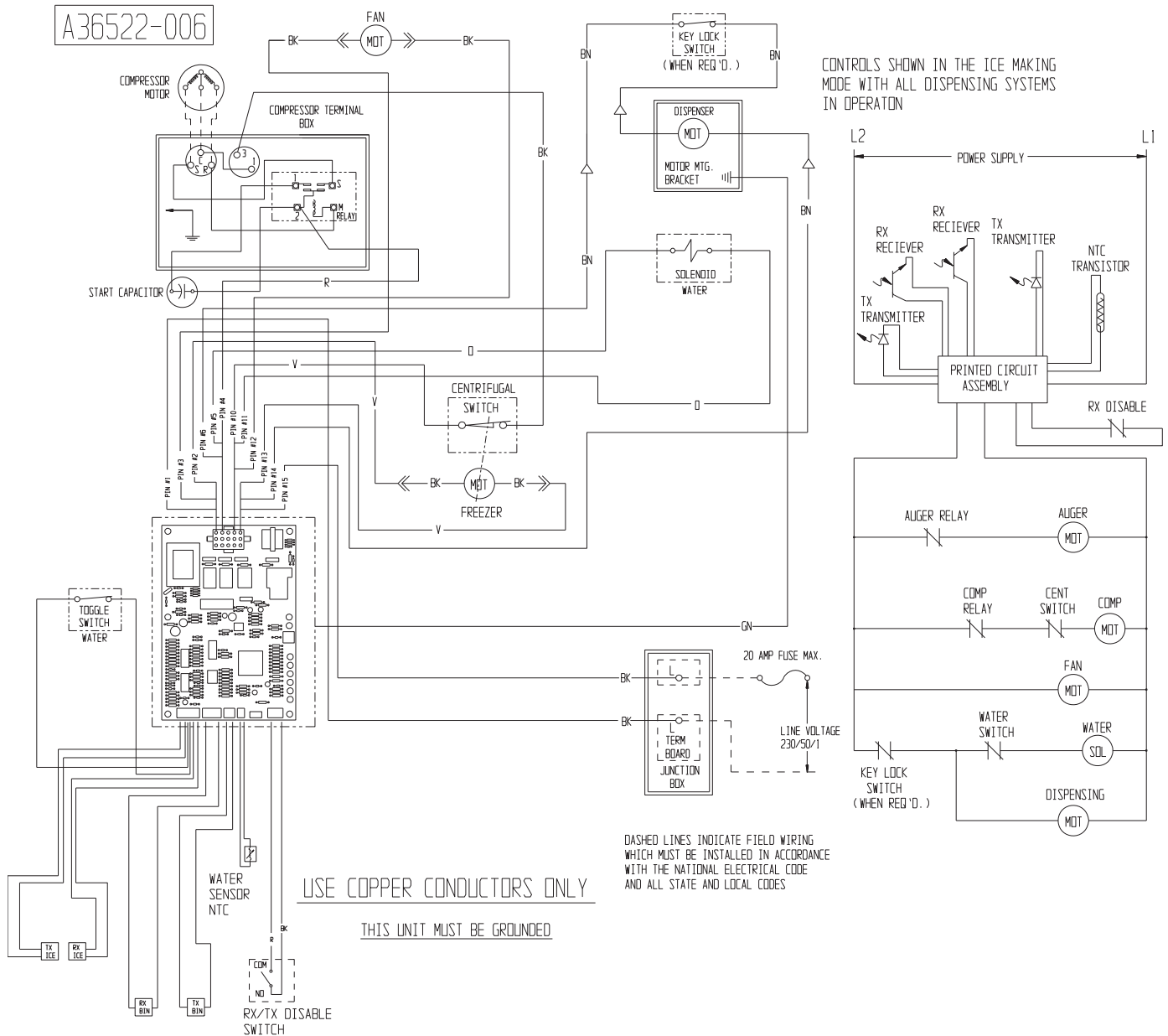

NAVSEA/SPAWAR TECHNICAL MANUAL DEFICIENCY/EVALUATION REPORT (TMDER)

INSTRUCTIONS: Continue on 8 1/2" x 11" page if additional space is needed.

1. Use this report to indicate deficiencies, problems and recommendations relating to publications.
2. For CLASSIFIED TMDERs see OPNAVINST 5510H for mailing requirements.
3. For TMDERs that affect more than one publication, submit a separate TMDER for each.
4. Submit TMDERs at web site <https://nsdsa2.phdnswc.navy.mil> or mail to: **COMMANDER, CODE 310 TMDER BLDG 1389, NAVSURFWARCENDIV NSDSA, 4363 MISSILE WAY, PORT HUENEME CA 93043-4307**

1. PUBLICATION NUMBER	2. VOL/PART	3. REV/DATE OR CHG/DATE	4. SYSTEM/EQUIPMENT ID	
5. TITLE OF PUBLICATION			6. REPORT CONTROL NUMBER (6 digit UIC-YY-any four: xxxxxx-03-xxxx)	
7. RECOMMEND CHANGES TO PUBLICATION				
7a. Page #	7b. Para #	7c. RECOMMENDED CHANGES AND REASONS		
8. ORIGINATOR'S NAME AND WORK CENTER		9. DATE	10. ORIGINATOR'S E-MAIL ADDRESS	11. TMA of Manual (NSDSA will complete)
12. SHIP OR ACTIVITY Name and Address (Include UIC/CAGE/HULL)		13. Phone Numbers: Commercial () - - DSN - - FAX () - -		

FOLD HERE AND TAPE SECURELY
PLEASE DO NOT STAPLE

INCLUDE COMPLETE ADDRESS

USE
PROPER
POSTAGE

FOR OFFICIAL USE ONLY

**COMMANDER
CODE 310 BLDG 1389
NAVSURFWARCENDIV NSDSA
4363 MISSILE WAY
PORT HUENEME CA 93043-4307**

FOLD HERE AND TAPE SECURELY
PLEASE DO NOT STAPLE