

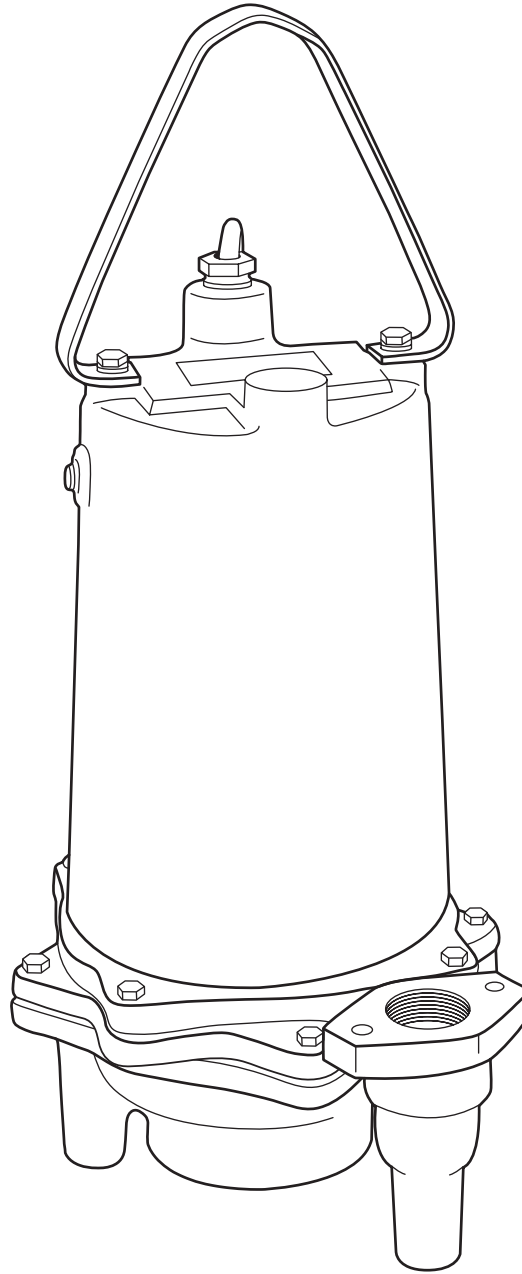

MYERS®



MODEL MRG20 GRINDER PUMP

INSTALLATION AND SERVICE MANUAL

2 HP Grinder Pump for Residential Applications.



NOTE! To the installer: Please make sure you provide this manual to the owner of the equipment or to the responsible party who maintains the system.

USAGE

The MRG20 is a submersible wastewater grinder pump designed specifically for individual residential applications. The pumps are to be used for domestic sewage only and are not to be used for pumping commercial or industrial sewage such as motels, schools, apartments, factories, etc. **THIS PUMP IS NOT FOR USE IN HAZARDOUS LOCATIONS!**

INSPECTING PUMP

Before making any piping or electrical connections, check the pump for shipping damage or cracks. Using a flat screwdriver placed in the slot on the shaft end, turn shaft and impellers to be sure they are free. **DO NOT TURN IMPELLER WITH FINGERS AS EDGES ARE SHARP.**

POWER SUPPLY

The MRG20 grinder pump should be connected only to a 230 volt, single phase, 60 Hz power source. The pump will draw approximately 9.1 amperes at minimum flow and 15.0 full load amperes. The pump must be connected to a grounded power socket. **DO NOT** cut off the ground pin from the power cord plug.

POWER CORD

A power cord is attached to the grinder pump via three insulated quick-disconnect terminals.

The power cord should be replaced if it has been damaged in any way or the cord jacket has become brittle.

MOTOR TYPE

The MRG20 grinder pump contains a 3/4 frame, 2 HP, single phase, 60 Hz, 3450 RPM, capacitor start - capacitor run motor with Class F insulation and built-in on-winding overload protection. Motor has upper and lower ball bearings and is oil-cooled and lubricated.

⚠ CAUTION!

THE MRG20 GRINDER PUMP SHOULD NEVER BE WORKED ON WITHOUT FIRST DISCONNECTING THE POWER CORD.

OIL TYPE

The motor housing contains dielectric transformer oil to provide good heat transfer and lubrication of ball bearings; no other lubrication is required. Oil level may be checked by removing the nut and washers from the top of the motor housing. The oil level should be 3-7/8" from the boss with pump setting

vertically. **Do not overfill with oil.** Only dielectric transformer oil obtained from a Myers authorized service center should be used.

PUMP SWITCH INSTALLATION INSTRUCTIONS

Mounting the Switch

1. Determine pumping range for installation. Do not tether less than 3-1/2" from pipe.
2. Tighten strap around discharge pipe, keeping switch cable between strap and pipe to prevent slippage.
3. Space small ties at least 1" apart. To readjust ties, press small tie tabs down.
4. To lock releasable tab, run remaining strap between tab and head. Tuck strap back through head.

Piggyback Plug Install

- ⚠ Electrical outlet must not be located in pump chamber.
 - ⚠ Electrical outlet voltage, piggyback plug voltage, and pump voltage must match.
1. Follow steps 1 through 4 of "Mounting the Switch."
 2. Insert switch's piggyback plug into outlet.
 3. Plug pump into piggyback plug.
 4. Check installation. Allow system to cycle to ensure proper operation.

Direct Wire Install

1. Follow steps 1 through 4 of "Mounting the Switch"
2. Further wiring of switch should be done by qualified professionals only.
3. Check installation. Allow system to cycle to ensure proper operation.

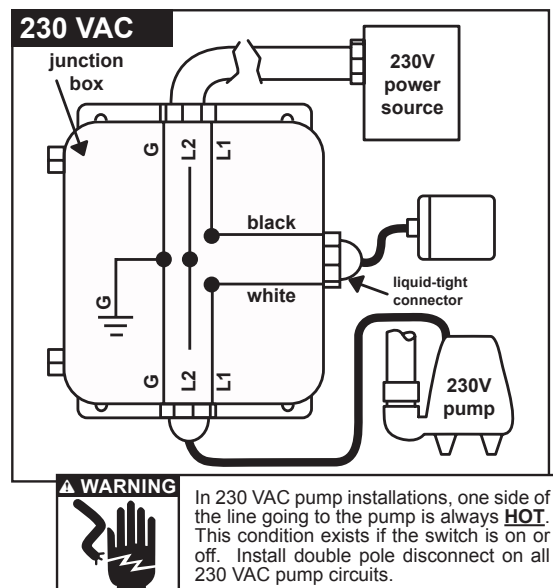

SAFETY WARNINGS

▲ WARNING! Risk of electrical shock. Pumps are supplied with a grounding conductor and grounding-type attachment plug on the power cord. To reduce the risk of electrical shock, be certain that it is connected only to properly grounded, grounding-type receptacle. **DO NOT** cut off ground pin or use an adapter fitting. **DO NOT** use an extension cord with this pump. When wiring this pump follow all local electrical, safety codes and ordinances as well as most recent National Electric Code (NEC-ANSI/NFPA).

The MRG20 grinder pumps have a GROUND WIRE that is connected to a screw in the metal motor housing. This wire goes to the receptacle or control

box which must be connected to follow all local electrical, safety codes and ordinances as well as most recent National Electric Code (NEC-ANSI/NFPA).

CALIFORNIA PROPOSITION 65 WARNING:

▲ WARNING This product and related accessories contain chemicals known to the State of California to cause cancer, birth defects or other reproductive harm.

DISMANTLING PUMP FOR REPLACEMENT PARTS

Before dismantling pump for replacement parts, clean pump thoroughly.

WIRING SCHEMATIC – AO SMITH®

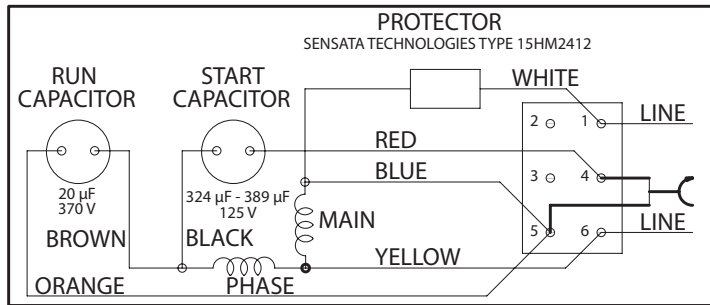

WIRING DIAGRAM – MARATHON®

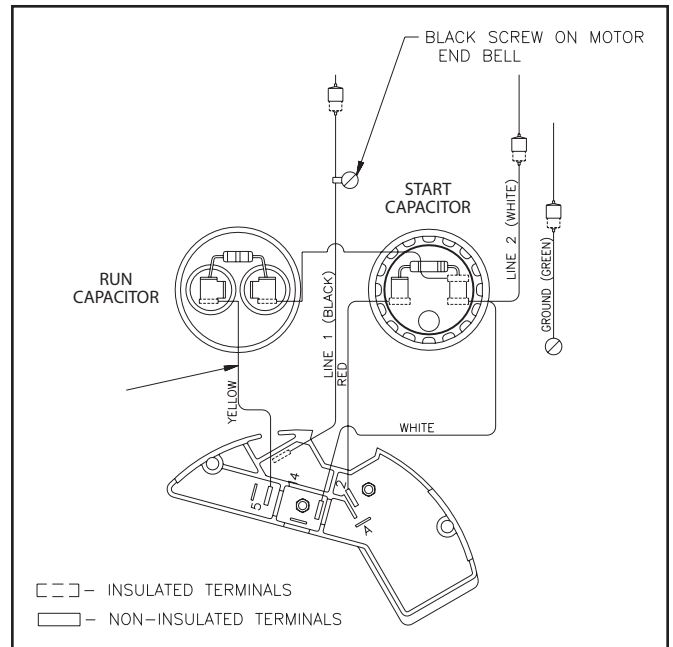

TROUBLESHOOTING GUIDE

Pump does not run or hum.

See A, B, C, D, E or F.

Pump runs but does not deliver water.

See G, H, I, J, K or L.

Pump runs and pumps out sump but does not stop.

See M.

Pump runs but delivers only small amount of water.

See I, J, K, L or N.

Fuse blows or circuit breaker trips when pump starts.

See K, L, N, O or P.

Motor runs for short time then stops. Then after short period starts again. Indicates tripping overload caused by symptom shown.

See K, L, N or P.

For any other symptoms contact a Myers authorized service facility.

- A.** Line circuit breaker may be off; or fuse, if used, may be blown or loose.
- B.** Water level in sump may be too low. Run in more water.
- C.** Pump cord plug may not be making contact in receptacle.
- D.** If pump is using the series cord plug, the two plugs may not be plugged tight together.
- E.** Float may be stuck. Be sure float operates freely in basin. Check tether length of switch.
- F.** If all symptoms check OK, motor winding may be open; take to service center for repair.
- G.** Check valve may be installed backward. Arrow on valve points in direction of flow.
- H.** Discharge shut-off valve, if used, may be closed.
- I.** Pump may be air locked. Start and stop several times by plugging and unplugging cord. Check vent hole on pump case for plugging.
- J.** Pump head may be too high. Horizontal distance does not affect pumping, except loss due to friction.
- K.** Inlet holes in pump base may be clogged. Remove pump and clean out openings.
- L.** Impeller or volute openings may be plugged or partially plugged. Remove pump and clean. Check tether length of switch.
- M.** Float is stuck in up position. Be sure float operates freely in basin.
- N.** Pump impeller may be partially clogged causing motor to run slow, resulting in motor overload.
- O.** Fuse size or circuit breaker is too small. Must be 20 amps.
- P.** Defective motor stator. Return to Myers service center.

MOTOR END PARTS

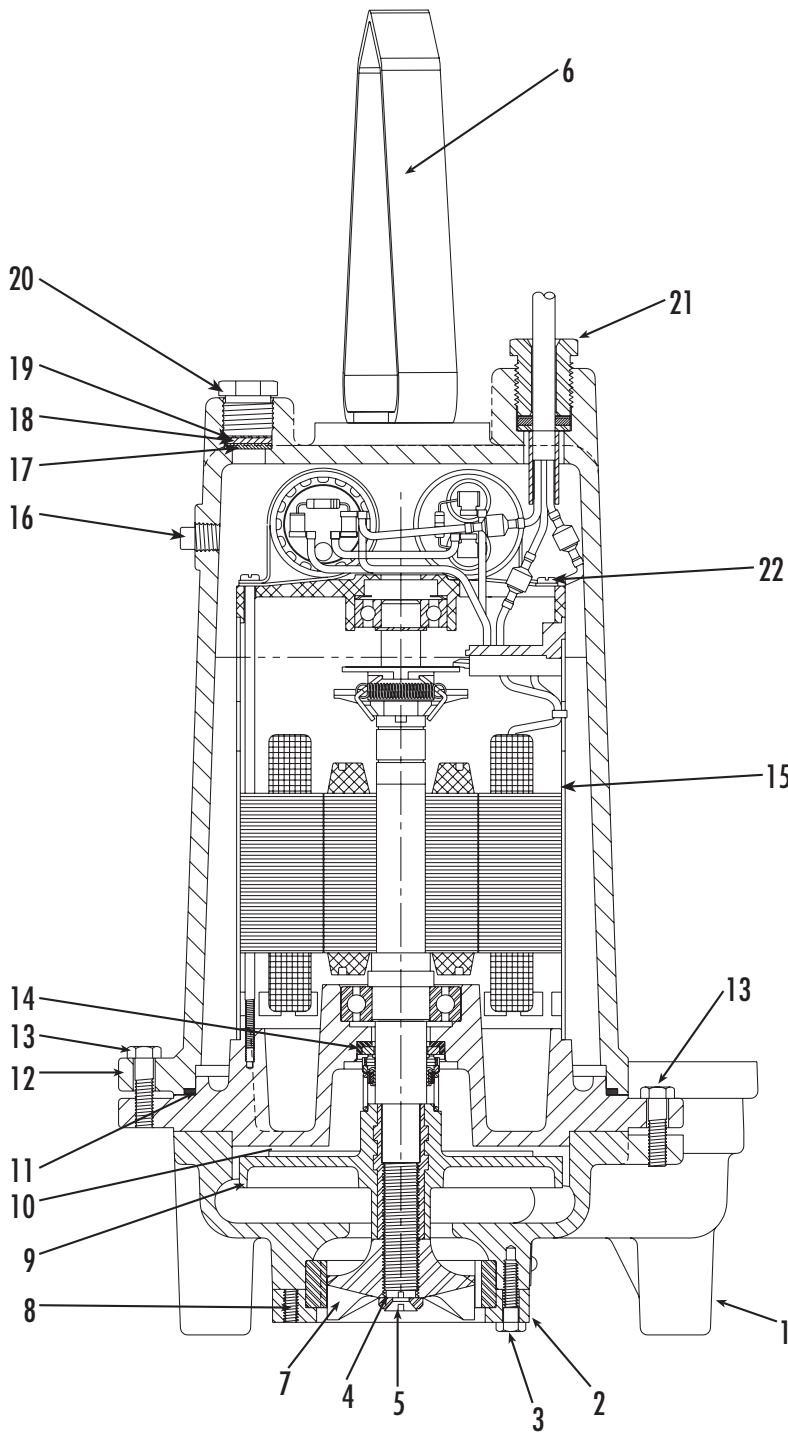

COMMON PARTS LIST

For use with product built with
AO Smith® motor.

Ref. No.	Part No.	Description
1	26433D002	CASE, VOLUTE
2	21584B000	FLANGE, W/SHREDDING RING
3	19099A012	SCREW, CAP 1/4" x 1" LONG., SST (3 REQ'D)
4	21583B000	RETAINER, IMPELLER, SST
5	07597A018	SCREW, FLAT HEAD, 1/4" x 3/4" LONG
6	25371B006	HANDLE
7	21582B000	IMPELLER, GRINDING
8	05013A039	SCREW, SET 1/4" x 3/8" LONG (2 REQ'D)
9	26434C010	IMPELLER, PUMP PLASTIC
	26434C000	IMPELLER, CAST IRON (OPTIONAL)
10	26430D001	PLATE, SEAL/BEARING
11	05014A181	GASKET, TETRASEAL 7" x 6-3/4" x 1/8"
12	145890022	HOUSING, MOTOR
13	19100A012	SCREW, CAP, 5/16" x 1-1/4" LONG (8 REQ'D)
14	21576A010	SEAL, 7/8" SHAFT
15	27739D000	MOTOR, 2 HP, 230V, 1 PH
16	05022A092	PLUG, PIPE 1/4 NPT
17	05030A235	WASHER, SST, 3/32" THICK
18	05014A193	GASKET, RUBBER
19	05030A234	WASHER, SST, 1/32" THICK
20	25341A002	NUT, SOLID
21	25338B001	CORD, POWER
22	145950201	SWITCH, FLOAT
-	152240021	RUN CAPACITOR
-	12141A018	START CAPACITOR

MOTOR END PARTS

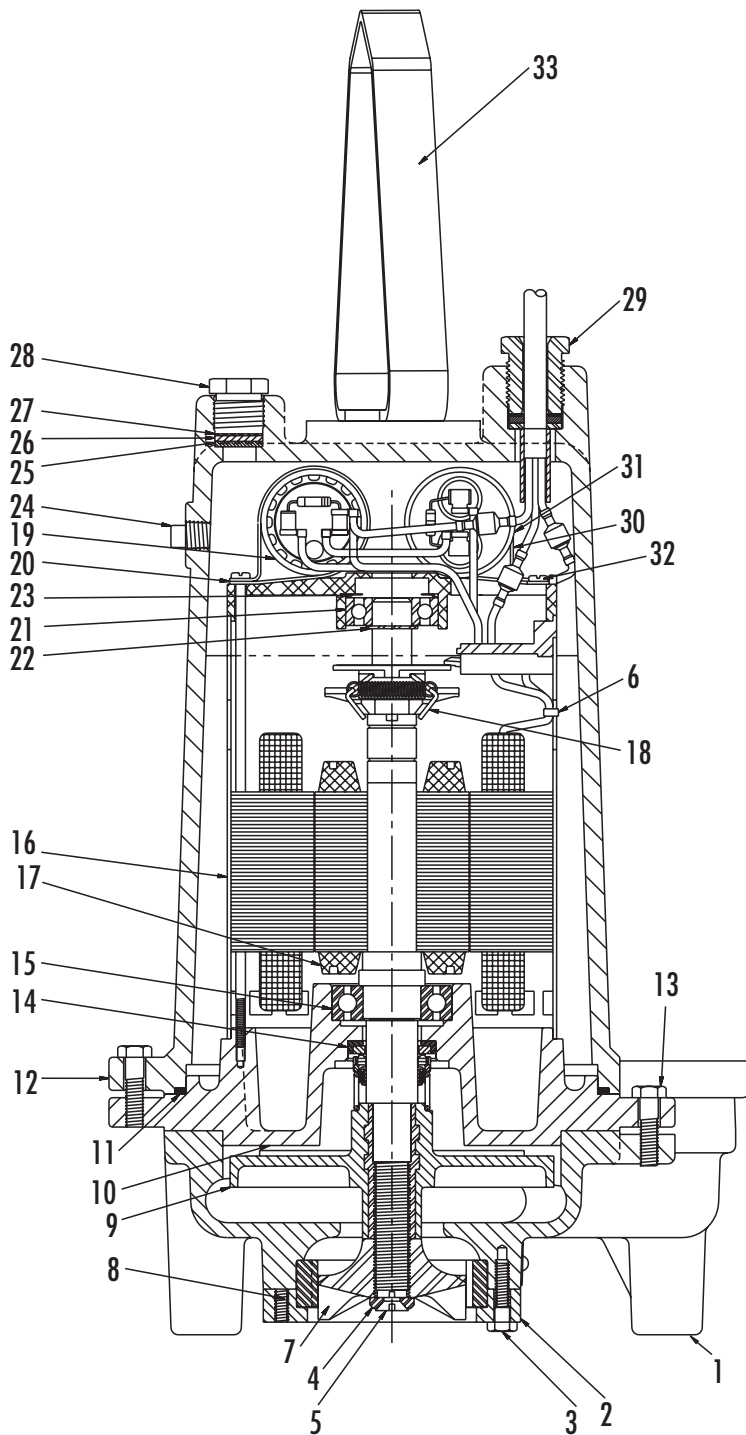

COMMON PARTS LIST

For use with product built with
Marathon® motor.

Ref.	Part Number	Description
1	26433D002	CASE, VOLUTE
2	21584B000	FLANGE, W/SHREDDING RING
3	19099A012	SCREW, CAP 1/4" x 1" LONG., SST (3 REQ'D)
4	21583B000	RETAINER, IMPELLER, SST
5	07597A018	SCREW, FLAT HEAD, 1/4" x 3/4" LONG
6	17190A004	CLAMP
7	21582B000	IMPELLER, GRINDING
8	05013A039	SCREW, SET 1/4" x 3/8" LONG (2 REQ'D)
9	26434C010	IMPELLER, PUMP PLASTIC MG200
	26434C000	IMPELLER, CAST IRON (OPTIONAL) MG200
10	26430D001	PLATE, SEAL/BEARING
11	05014A181	GASKET, TETRASEAL 7" x 6-3/4" x 1/8"
12	145890021	HOUSING, MOTOR
13	19100A012	SCREW, CAP, 5/16" x 1-1/4" LONG (8 REQ'D)
14	21576A010	SEAL, 7/8" SHAFT
15	08565A018	BEARING, LOWER
16	N/A	STATOR, W/SHELL, 2 HP, 230V, 1 PH
17	N/A	ROTOR, W/SHAFT
18	24481A008	SWITCH, MECHANICAL
19	12141A015	CAPACITOR, START WITH RESISTOR
20	20333A001	CLIP, CAPACITOR
21	08565A013	BEARING, UPPER
22	12558A030	RING, RETAINING
23	19331A005	WASHER, SPRING FINGER
24	05022A009	PLUG, PIPE 1/4 NPT
25	05030A235	WASHER, SST, 3/32" THICK
26	05014A193	GASKET, RUBBER
27	05030A234	WASHER, SST, 1/32" THICK
28	25341A002	NUT, SOLID
29	25338B001	CORD, POWER
30	20333A004	CLIP, CAPACITOR
31	23838A010	CAPACITOR, RUN WITH RESISTOR
32	145950201	SWITCH, FLOAT
33	25371B006K	HANDLE

Entire motor can be replaced with 27739D000.

THIS PAGE INTENTIONALLY LEFT BLANK

STANDARD LIMITED WARRANTY

Pentair Myers® warrants its products against defects in material and workmanship for a period of 12 months from the date of shipment from Pentair Myers or 18 months from the manufacturing date, whichever occurs first – provided that such products are used in compliance with the requirements of the Pentair Myers catalog and technical manuals for use in pumping raw sewage, municipal wastewater or similar, abrasive-free, noncorrosive liquids.

During the warranty period and subject to the conditions set forth, Pentair Myers, at its discretion, will repair or replace to the original user, the parts that prove defective in materials and workmanship. Pentair Myers reserves the right to change or improve its products or any portions thereof without being obligated to provide such a change or improvement for prior sold and/or shipped units.

Start-up reports and electrical schematics may be required to support warranty claims. Submit at the time of start-up through the Pentair Myers website: <http://forms.pentairliterature.com/startupform/startupform.asp?type=m>. Warranty is effective only if Pentair Myers authorized control panels are used. All seal fail and heat sensing devices must be hooked up, functional and monitored or this warranty will be void. Pentair Myers will cover only the lower seal and labor thereof for all dual seal pumps. Under no circumstance will Pentair Myers be responsible for the cost of field labor, travel expenses, rented equipment, removal/reinstallation costs or freight expenses to and from the factory or an authorized Pentair Myers service facility.

This limited warranty will not apply: (a) to defects or malfunctions resulting from failure to properly install, operate or maintain the unit in accordance with the printed instructions provided; (b) to failures resulting from abuse, accident or negligence; (c) to normal maintenance services and parts used in connection with such service; (d) to units that are not installed in accordance with applicable local codes, ordinances and good trade practices; (e) if the unit is moved from its original installation location; (f) if unit is used for purposes other than for what it is designed and manufactured; (g) to any unit that has been repaired or altered by anyone other than Pentair Myers or an authorized Pentair Myers service provider; (h) to any unit that has been repaired using non factory specified/OEM parts.

Warranty Exclusions: PENTAIR MYERS MAKES NO EXPRESS OR IMPLIED WARRANTIES THAT EXTEND BEYOND THE DESCRIPTION ON THE FACE HEREOF. PENTAIR MYERS SPECIFICALLY DISCLAIMS THE IMPLIED WARRANTIES OF MERCHANTABILITY AND FITNESS FOR ANY PARTICULAR PURPOSE.

Liability Limitation: IN NO EVENT SHALL PENTAIR MYERS BE LIABLE OR RESPONSIBLE FOR CONSEQUENTIAL, INCIDENTAL OR SPECIAL DAMAGES RESULTING FROM OR RELATED IN ANY MANNER TO ANY PENTAIR MYERS PRODUCT OR PARTS THEREOF. PERSONAL INJURY AND/OR PROPERTY DAMAGE MAY RESULT FROM IMPROPER INSTALLATION. PENTAIR MYERS DISCLAIMS ALL LIABILITY, INCLUDING LIABILITY UNDER THIS WARRANTY, FOR IMPROPER INSTALLATION. PENTAIR MYERS RECOMMENDS INSTALLATION BY PROFESSIONALS.

Some states do not permit some or all of the above warranty limitations or the exclusion or limitation of incidental or consequential damages and therefore such limitations may not apply to you. No warranties or representations at any time made by any representatives of Pentair Myers shall vary or expand the provision hereof.



MYERS®

1101 MYERS PARKWAY
ASHLAND, OHIO, USA 44805
419-289-1144

490 PINEBUSH ROAD, UNIT #4
CAMBRIDGE, ONTARIO, CANADA N1T 0A5
800-363-PUMP

WWW.FEMYERS.COM