

SPLIT TYPE
ROOM AIR CONDITIONER
FLOOR TYPE

SERVICE MANUAL

Indoor unit	Outdoor unit
AGYG09LVCA	AOYG09LVCA
AGYG12LVCA	AOYG12LVCA



CONTENTS

SPECIFICATIONS.....	1
DIMENSIONS.....	2
REFRIGERANT SYSTEM DIAGRAM.....	3
CIRCUIT DIAGRAM.....	4
INDOOR PCB CIRCUIT DIAGRAM.....	5
OUTDOOR PCB CIRCUIT DIAGRAM.....	8
ERROR DETECTION.....	10
PARTS (INDOOR UNIT).....	11
PARTS (OUTDOOR UNIT).....	16
ACCESSORIES.....	18

SPECIFICATIONS

ELECTRICAL DATA

TYPE		Cool & heat inverter	
INDOOR UNIT		AGYG09LVCA	AGYG12LVCA
OUTDOOR UNIT		AOYG12LVCA	AOYG12LVCA
COOLING CAPACITY		2.60 kW	3.50 kW
HEATING CAPACITY		3.50 kW	4.50 kW
POWER SOURCE		230 V	230 V
FREQUENCY		50 Hz	50 Hz
RUNNING CURRENT	Cooling	2.7 A	4.4 A
	Heating	3.9 A	5.6 A
INPUT WATTS	Cooling	0.53 kW	0.91 kW
	Heating	0.79 kW	1.19 kW
E.E.R.	Cooling	4.91 kW/kW	3.85 kW/kW
COP	Heating	4.43 kW/kW	3.78 kW/kW
MOISTURE REMOVAL		1.3 L/hr	1.8 L/h
AIR CIRCULATION HIGH	Cooling	570 m3/hr	570 m3/hr
	Heating	600 m3/hr	600 m3/hr
MAXIMUM CURRENT	Cooling	9.0 A	9.0 A
	Heating	11.5 A	11.5 A

FAN MOTOR

POWER SOURCE		230 V	
INDOOR UNIT cooling (upper fan / lower fan)	High	1,190 r.p.m. / 1,000 r.p.m.	
	Medium	1,000 r.p.m. / 850 r.p.m.	
	Low	820 r.p.m. / 690 r.p.m.	
	Quiet	660 r.p.m. / 560 r.p.m.	
INDOOR UNIT heating (upper fan / lower fan)	High	1,240 r.p.m. / 1,040 r.p.m.	
	Medium	1,040 r.p.m. / 880 r.p.m.	
	Low	840 r.p.m. / 700 r.p.m.	
	Quiet	660 r.p.m. / 560 r.p.m.	
OUTDOOR UNIT Cooling		870 r.p.m.	
OUTDOOR UNIT Heating		780 r.p.m.	

NOISE LEVEL

INDOOR UNIT Cooling	High	40 dB	
	Medium	35 dB	
	Low	29 dB	
	Quiet	22 dB	
INDOOR UNIT Heating	High	40 dB	
	Medium	35 dB	
	Low	29 dB	
	Quiet	22 dB	
OUTDOOR UNIT Cooling		47 dB	48 dB
OUTDOOR UNIT Heating		49 dB	50 dB

COMPRESSOR AND REFRIGERANT

COMPRESSOR TYPE	Hermetic type, 4 pole, 3 phase, Rotary, DC inverter motor	
DISCRIMINATION	DA89X1C-20FZ	DA89X1C-20FZ2
WEIGHT (with oil)	9.8 kg	9.2 kg
PRECHARGED REFRIGERANT	1,050 g	
REFRIGERANT TYPE	R410A	
FULL CHARGE	Pipe length 15 m	1,050 g
	20 m	1,150 g
ADDITIONAL CHARGE	20 g/m	
MAXIMUM PIPING HEIGHT	15m	

DIMENSIONS

INDOOR UNIT H x W x D	600 x 740 x 200 mm
OUTDOOR UNIT H x W x D	540 x 790 x 290 mm

WEIGHT

INDOOR UNIT Net / Shipping	14 kg / 17 kg
OUTDOOR UNIT Net / Shipping	40 kg / 36 kg

DIMENSIONS

unit : mm

INDOOR UNIT

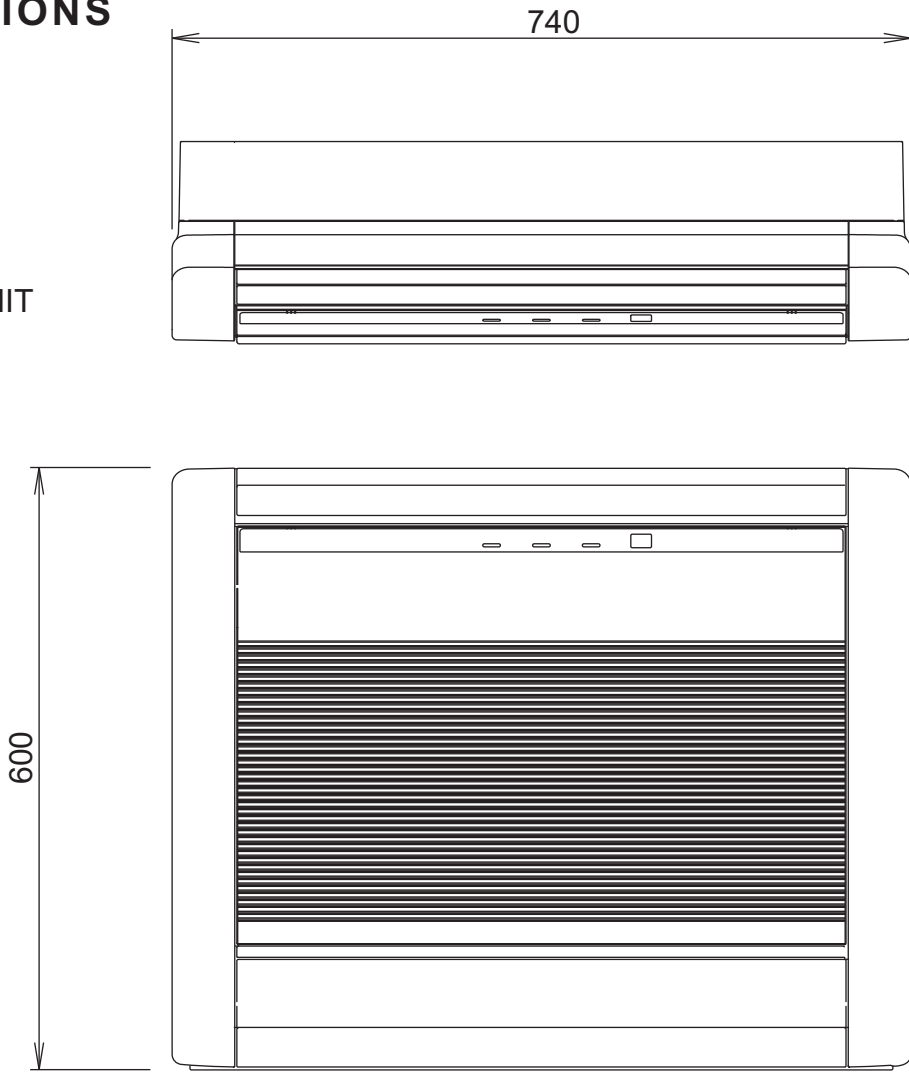

Drain hose length :
600 mm

Drain pipe diameter
Inside : 14.2 mm
Outside : 16.2 mm

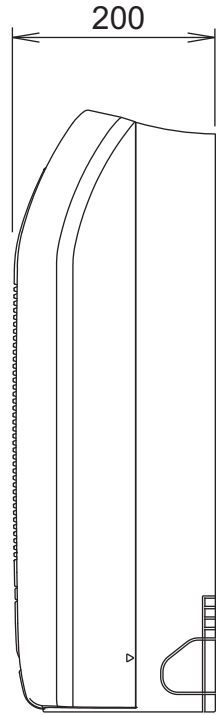

OUTDOOR UNIT

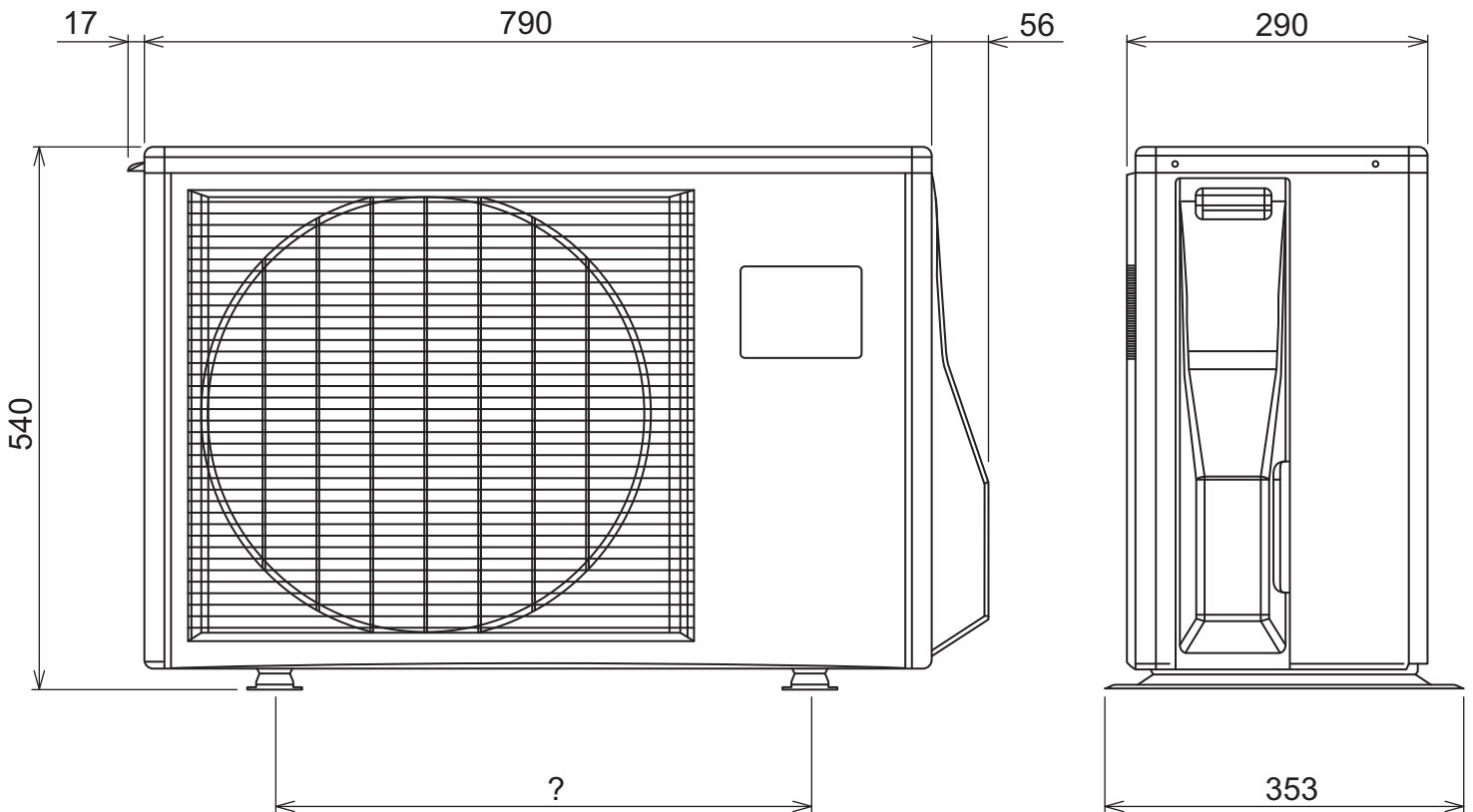

REFRIGERANT SYSTEM DIAGRAM

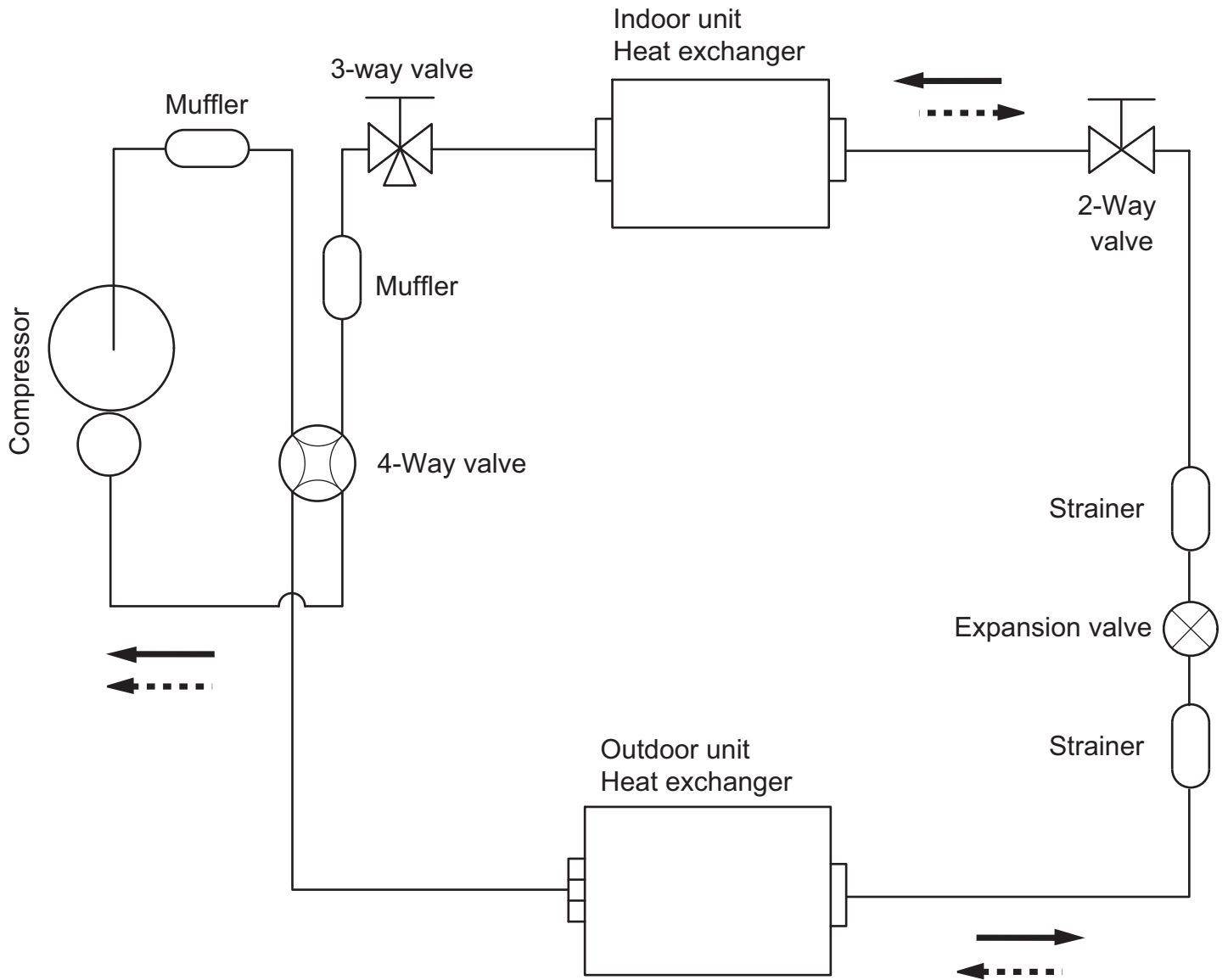

Refrigerant flow
 ———→ Cooling
 - - - -> Heating

Refrigerant pipe diameter
 Liquid : 1/4" (6.35 mm)
 Gas : 3/8" (9.52 mm)

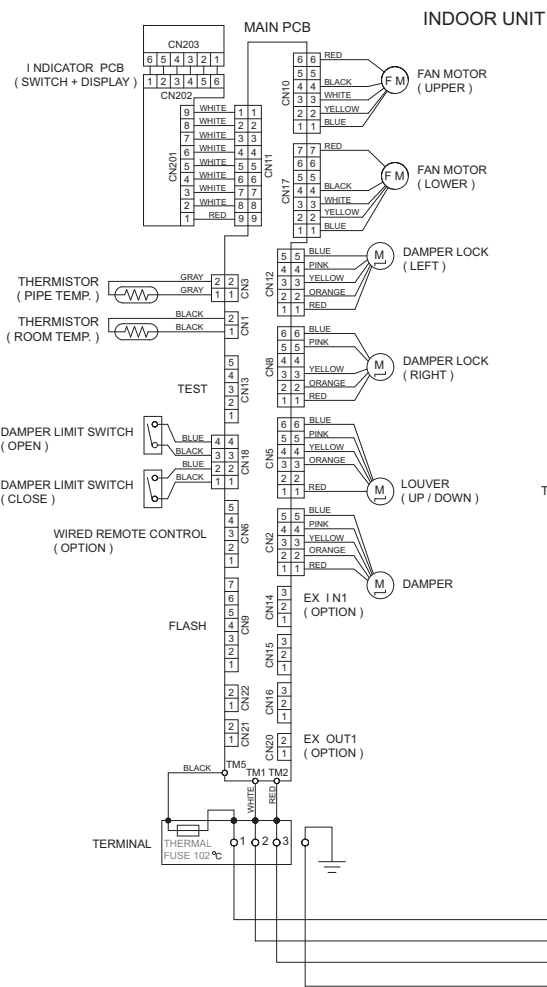

CIRCUIT DIAGRAM

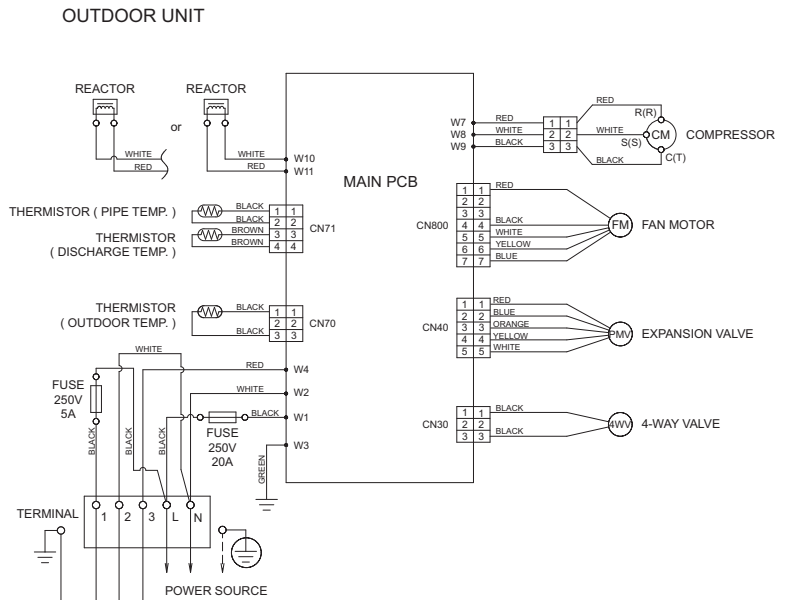

INDOOR PCB CIRCUIT DIAGRAM

CONTROL UNIT
 AGYG09LVCA : EZ-01216HSE
 AGYG12LVCA : EZ-01217HSE

INDICATOR PCB
 (SWITCH + DISPLAY)
 K06DD-0801HSE-F0

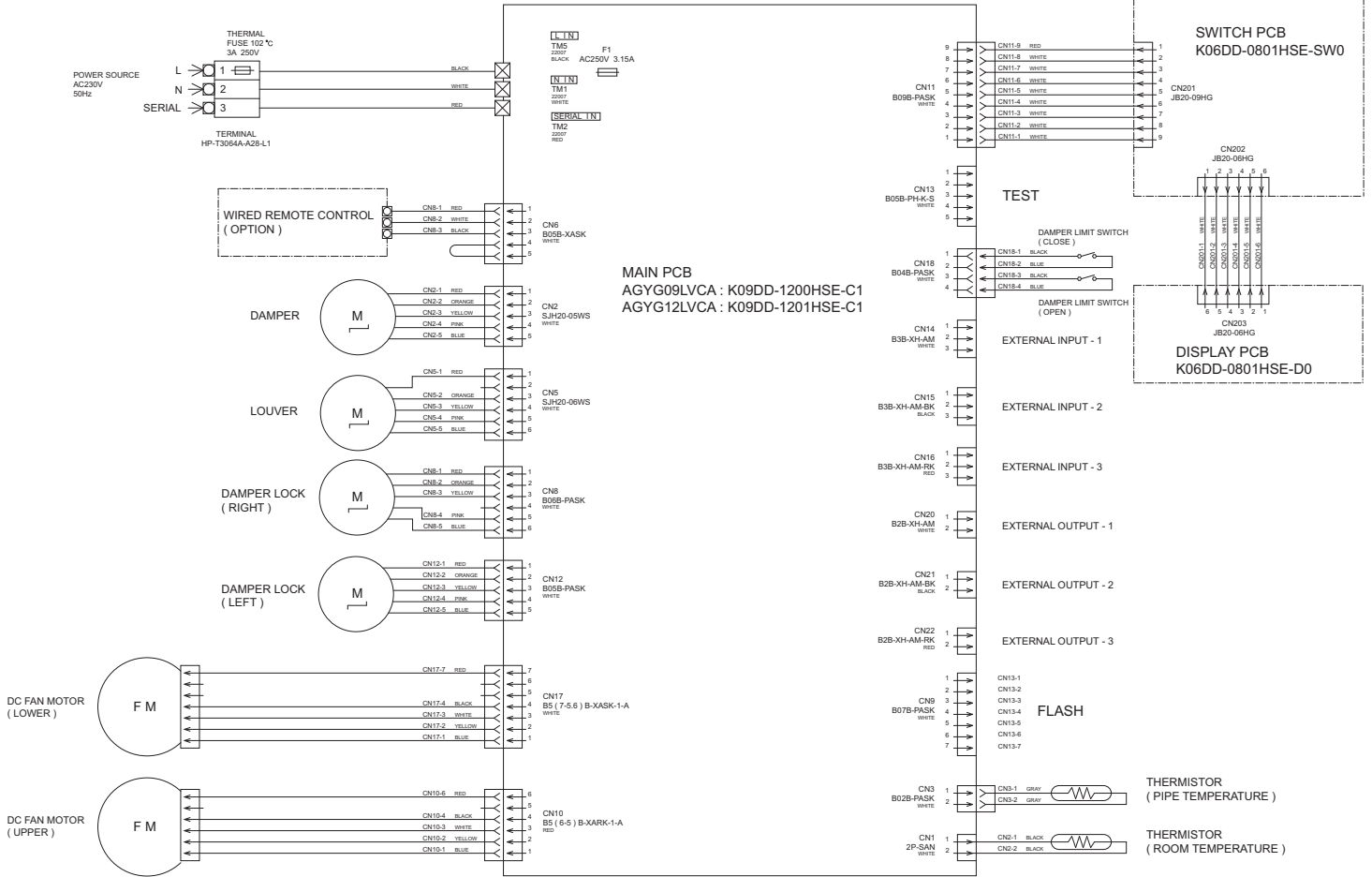

INDOOR UNIT
 MAIN PCB
 AGYG09LVCA : K09DD-1200HSE-C1
 AGYG12LVCA : K09DD-1201HSE-C1

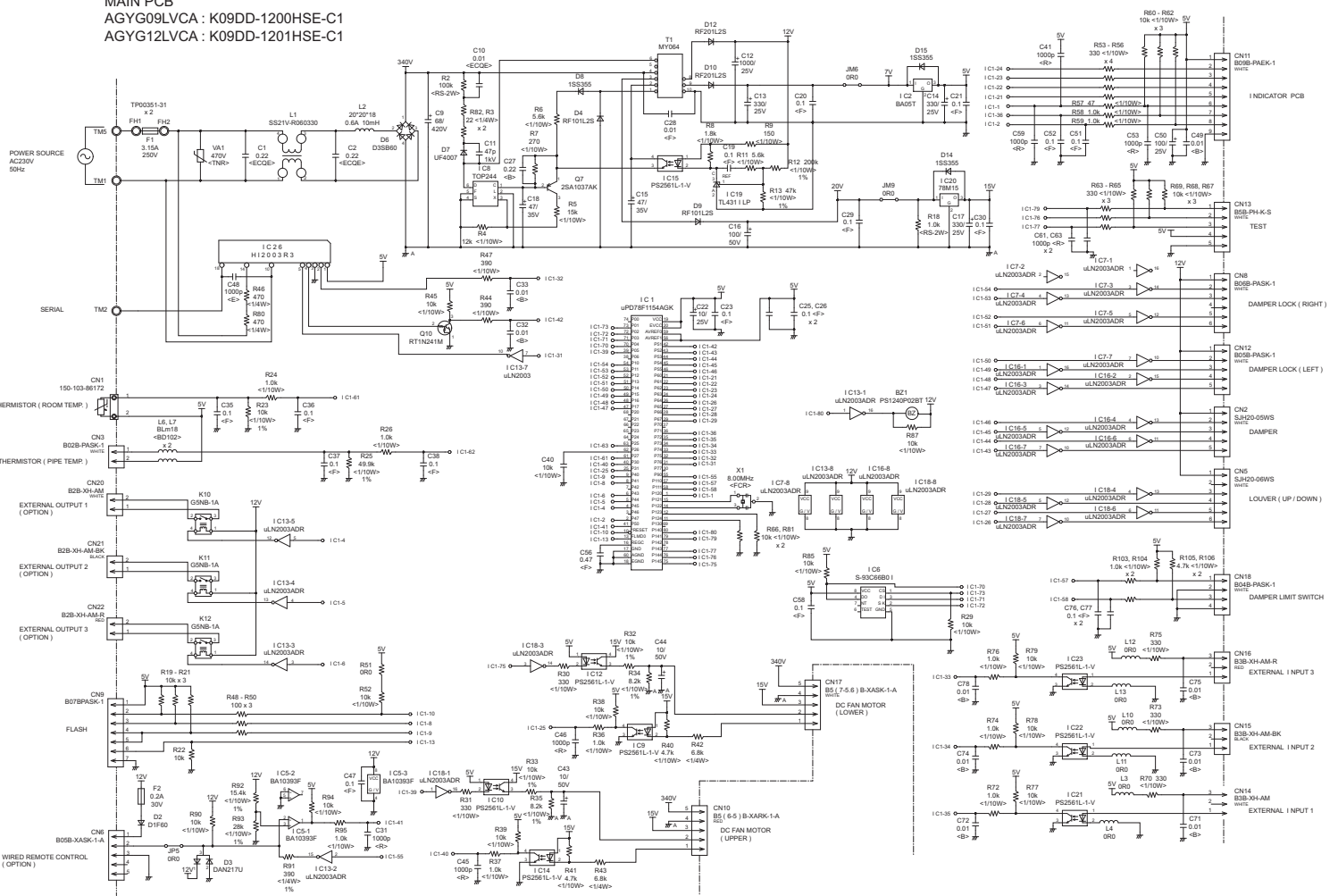

INDOOR UNIT
 INDICATOR PCB
 K06DD-0801HSE-F0

K06DD-0801HSE-D0

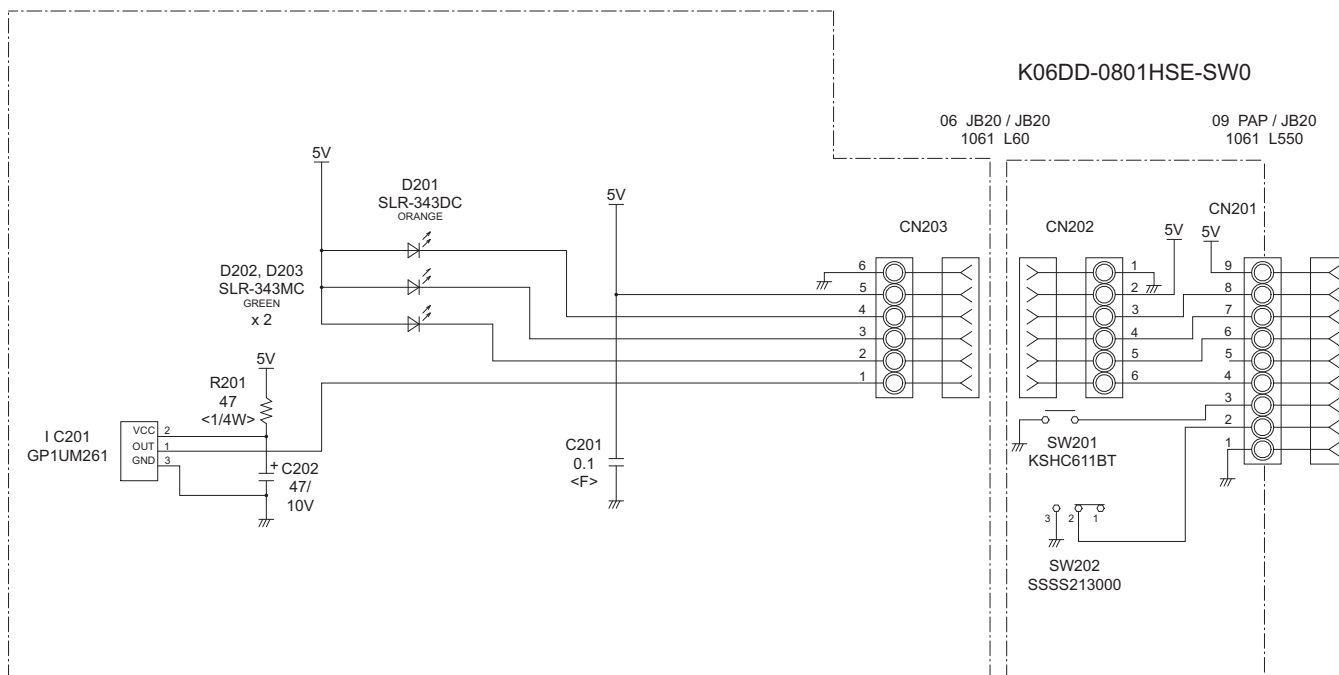

OUTDOOR UNIT
 MAIN PCB
 AOYG09LVCA : K10CT-1202HUE-C1
 AOYG12LVCA : K10CT-1203HUE-C1

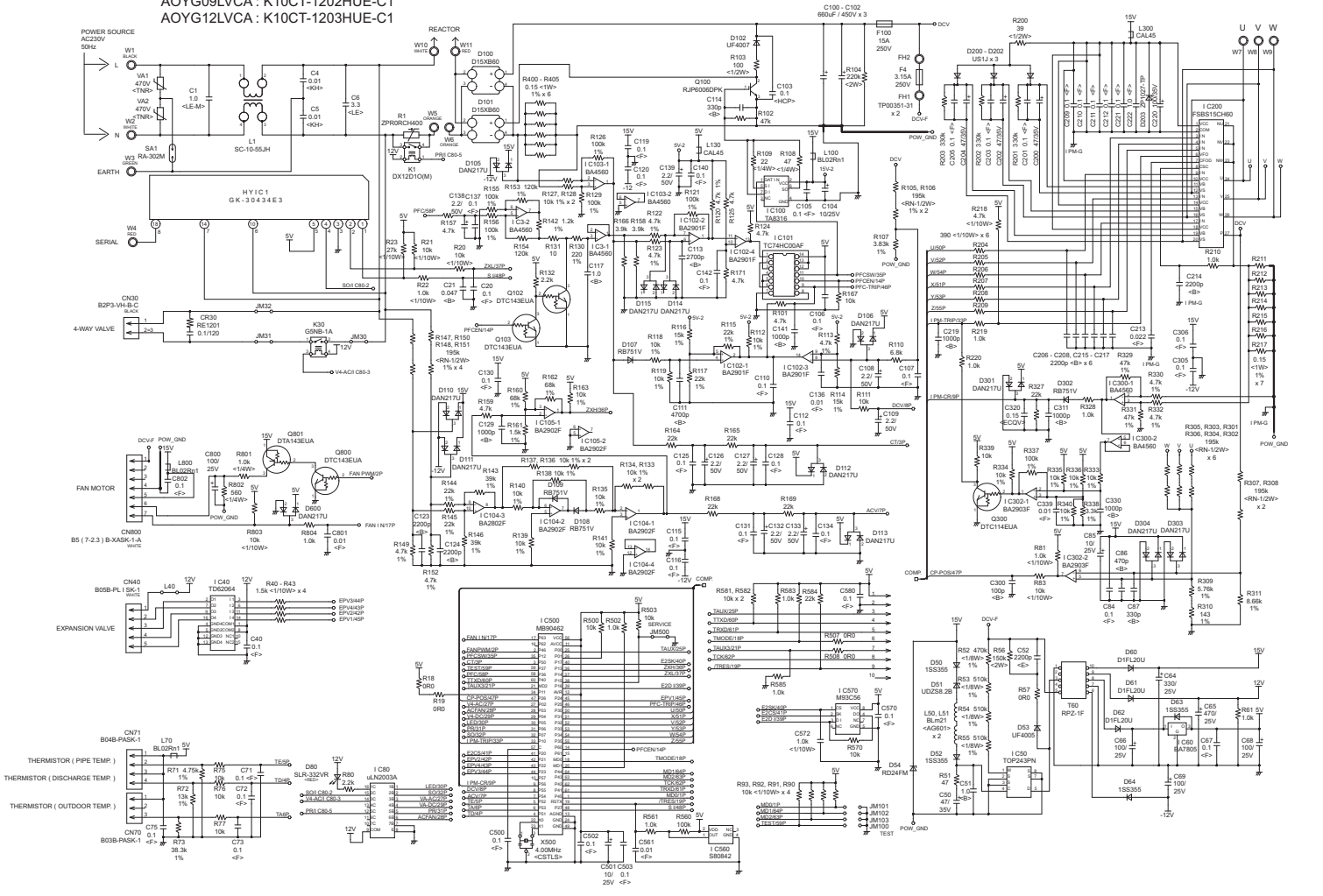

ERROR DETECTION

If you use a wireless remote control, the lamp on the photo detector unit will output error codes by way of blinking patterns.
If you use a wired remote control, error codes will appear on the remote control display.

See the lamp blinking patterns and error codes in the table.
An error display is displayed only during operation.

Wired remote control display (Option)

If an error occurs, the following display will be shown.
("Er" will appear in the set room temperature display.)

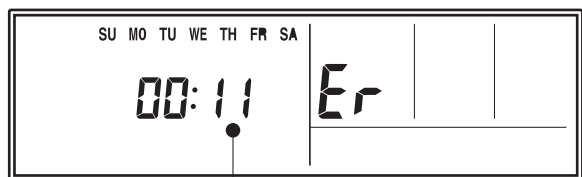

Indoor unit display

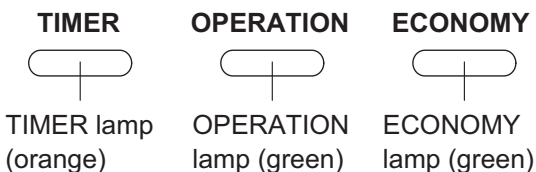
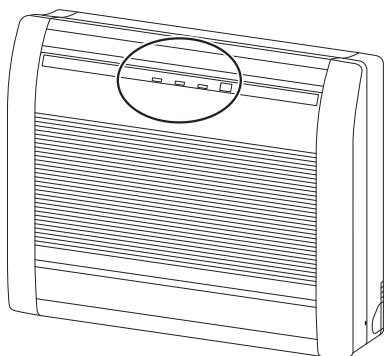

Error display			Wired remote control Error code	Description
OPERATION lamp (green)	TIMER lamp (orange)	ECONOMY lamp (green)		
● (1)	● (1)	◇	11	Serial communication error
● (1)	● (2)	◇	12	Wired remote control communication error
● (3)	● (2)	◇	32	Indoor unit PCB model information error
● (3)	● (5)	◇	35	Manual auto switch error
● (4)	● (1)	◇	41	Inlet air temp. sensor error
● (4)	● (2)	◇	42	Indoor unit Heat Ex. Middle temp. sensor error
● (5)	● (1)	◇	51	Indoor unit fan motor error
● (5)	● (7)	◇	57	Damper error
● (6)	● (2)	◇	62	Outdoor unit main PCB model information error or communication error
● (6)	● (4)	◇	64	Active filter error
● (6)	● (5)	◇	65	Trip terminal L error
● (7)	● (1)	◇	71	Discharge temp. sensor error
● (7)	● (3)	◇	73	Outdoor unit Heat Ex. liquid temp. sensor error
● (7)	● (4)	◇	74	Outdoor temp. sensor error
● (8)	● (4)	◇	84	Current sensor error
● (9)	● (4)	◇	94	Trip detection
● (9)	● (5)	◇	95	Compressor rotor position detection error (permanent stop)
● (9)	● (7)	◇	97	Outdoor unit fan motor error
● (9)	● (9)	◇	99	4-way valve error
● (10)	● (1)	◇	A1	Discharge temp. error

● : 0.5s on / 0.5s off
◇ : 0.1s on / 0.1s off
() : Number of flash

PARTS

INDOOR UNIT

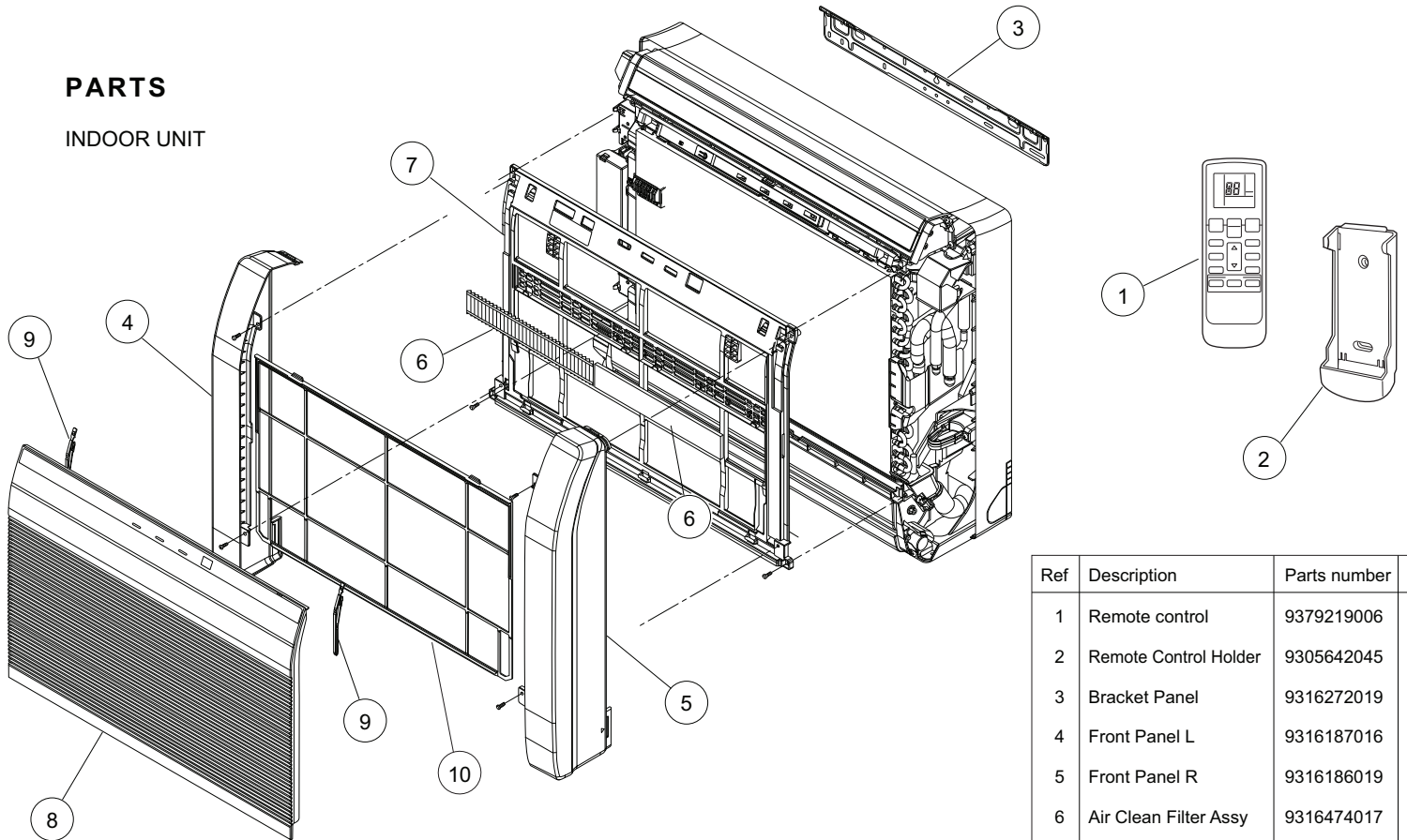

Ref	Description	Parts number
1	Remote control	9379219006
2	Remote Control Holder	9305642045
3	Bracket Panel	9316272019
4	Front Panel L	9316187016
5	Front Panel R	9316186019
6	Air Clean Filter Assy	9316474017
7	Front Panel	9316185012
8	Intake Grille Assy	9316418059
9	Rope Assy	9316458017
10	Air Filter	9316189010

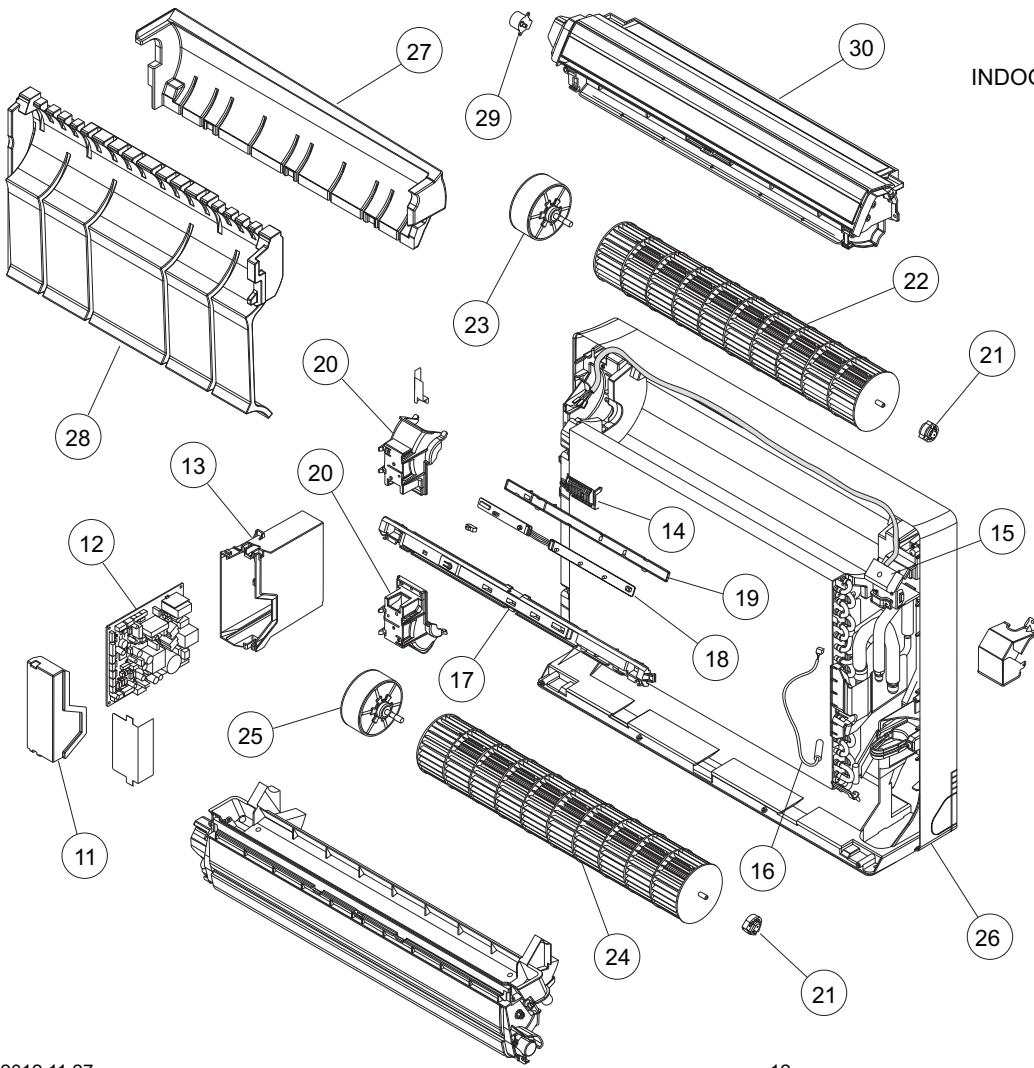

INDOOR UNIT

Ref	Description	Parts number
11	Control Cover	9316201019
12	Main PCB (09)	9708532073
12	Main PCB (12)	9708532080
13	Control Box	9316200012
14	Thermistor Holder	9316192010
15	Terminal	9900385026
16	Pipe Thermistor	9900425012
17	Display Case	9316194014
18	Indicator PCB	9707571042
19	Display Cover	9316191013
20	Motor Holder	9316195011
21	Bearing C Assy	9306628017
22	Crossflow Fan Assy	9312004034
23	Fan Motor, MFD-14TXN	9602850006
24	Crossflow Fan B Assy	9316309012
25	Fan Motor, MFD-14SXX	9602851003
26	Base	9316193017
27	Base Cover A	9316197015
28	Base Cover B	9316373013
29	Step Motor (Up / down)	9900384043
30	Casing Assy	9316411012

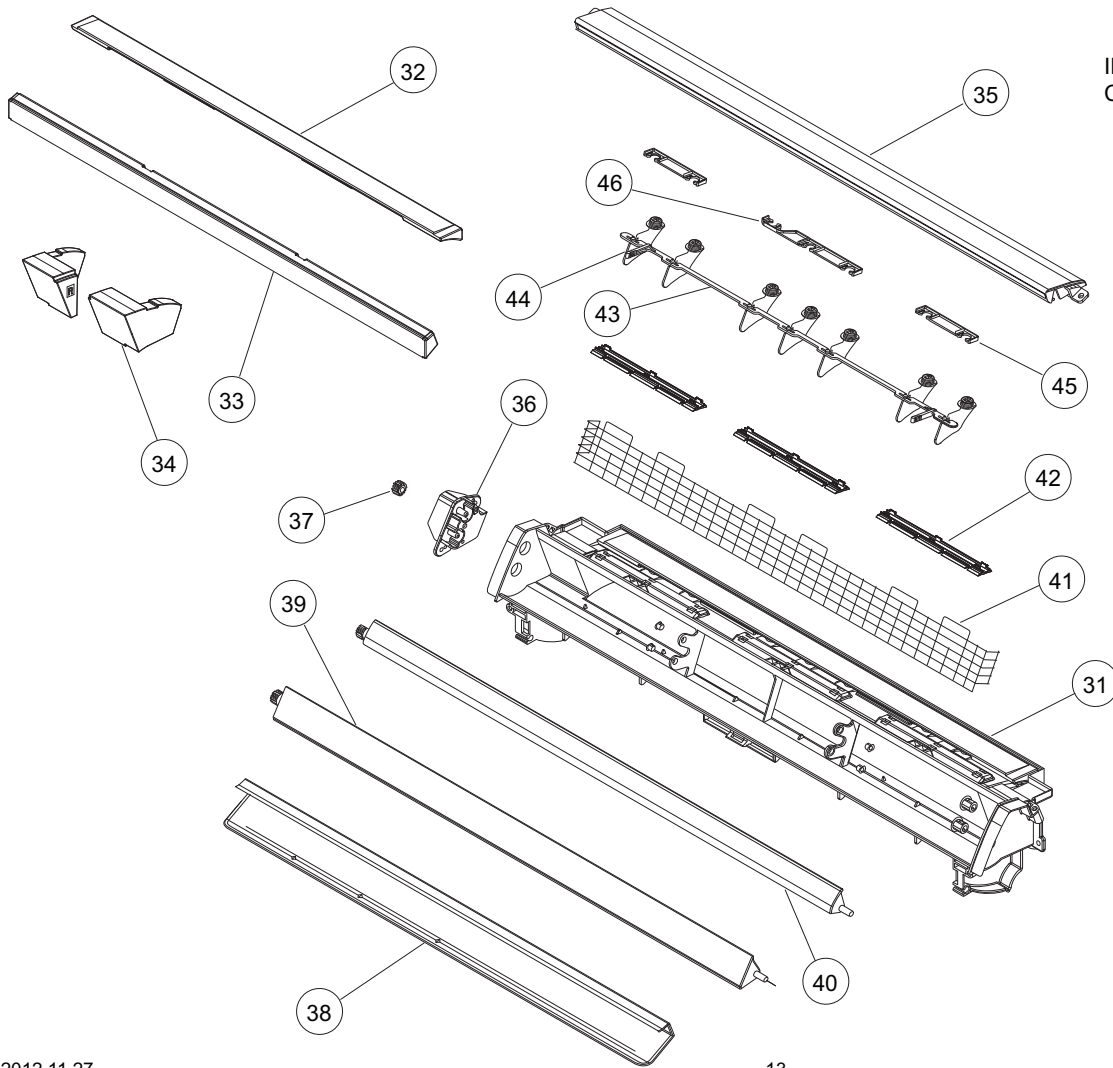

INDOOR UNIT
Casing assy

Ref	Description	Parts number
31	Casing	9316204010
32	Casing Cover B	9316273016
33	Casing Cover F	9316308015
34	Casing Cover LR	9316310018
35	Top Cover	9316207011
36	Gear Case	9316213012
37	Gear A	9309994003
38	Reinforcement	9316378018
39	Louver Z (Lower)	9316206014
40	Louver U (Upper)	9316205017
41	Fan Guard	9316211018
42	Guard Holder	9316210011
43	Joint U	9316209015
44	R and L Louver U	9316208018
45	Spacer C	9315281012
46	Spacer D	9315282019

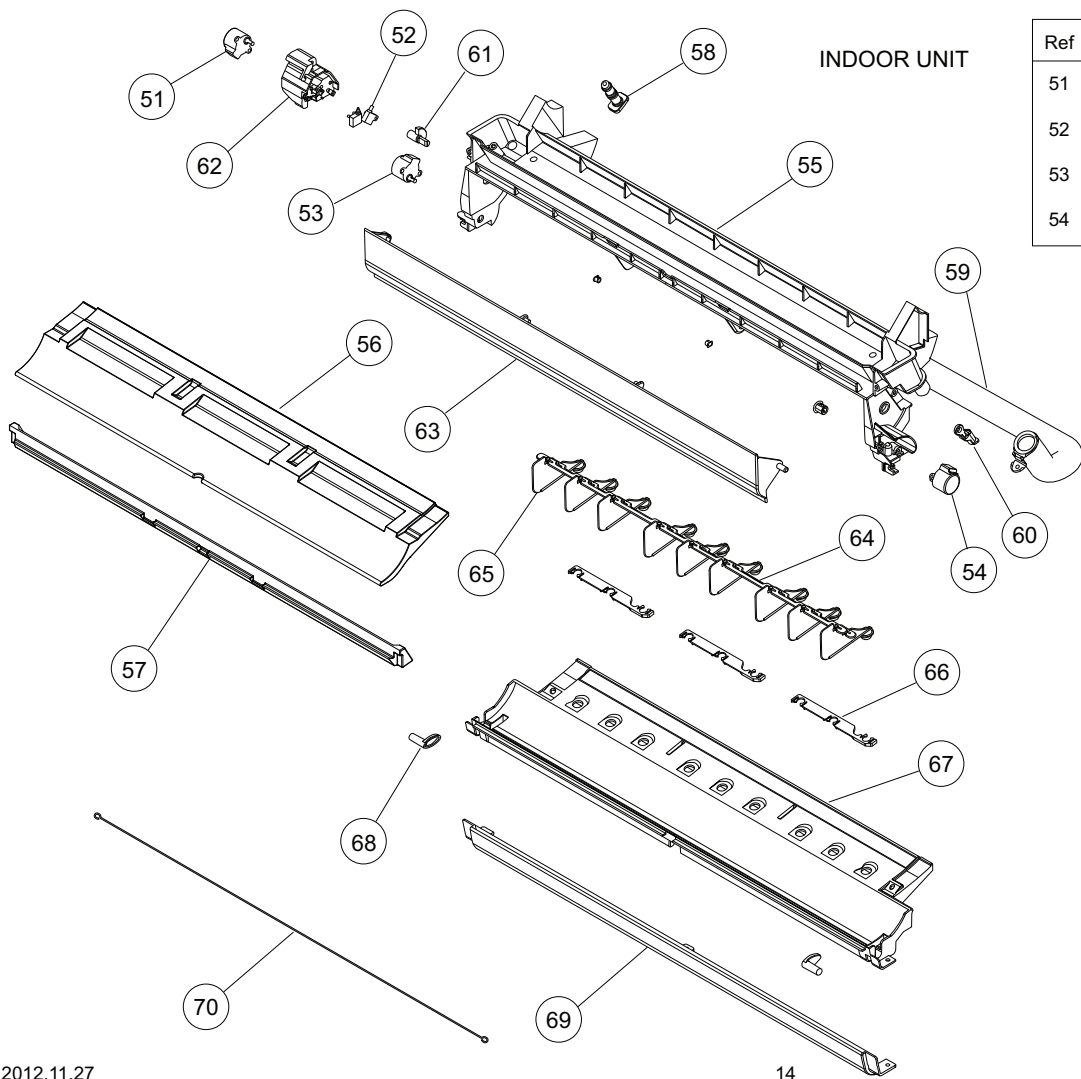

Ref	Description	Parts number
51	Motor Step (Damper)	9900384050
52	Micro Switch (Limit Switch)	9900424015
53	Motor Step (Damper Lock Left)	9900384067
54	Step Motor (Damper Lock Right)	9900384074

Drain Pan Assy

Ref	Description	Parts number
--	Drain Pan Assy	9316412019
55	Drain Pan U	9316214019
56	Drain Pan Cover B	9316386013
57	Drain Pan Cover F	9316274013
58	Drain Cap	9316177017
59	Drain Hose Assy	9314147029
60	Drain Holder	9316384019
61	Key Top	9316218017
62	Limit Switch Cover	9316217010
63	Damper	9316216013
64	Joint Z	9316335011
65	R and L Louver Z	9316334014
66	Spacer D	9315282019
67	Drain Pan Z	9316215016
68	Stopper	9316219014
69	Under Cover	9316374010
70	Fan Guard Z	9316918009

INDOOR UNIT

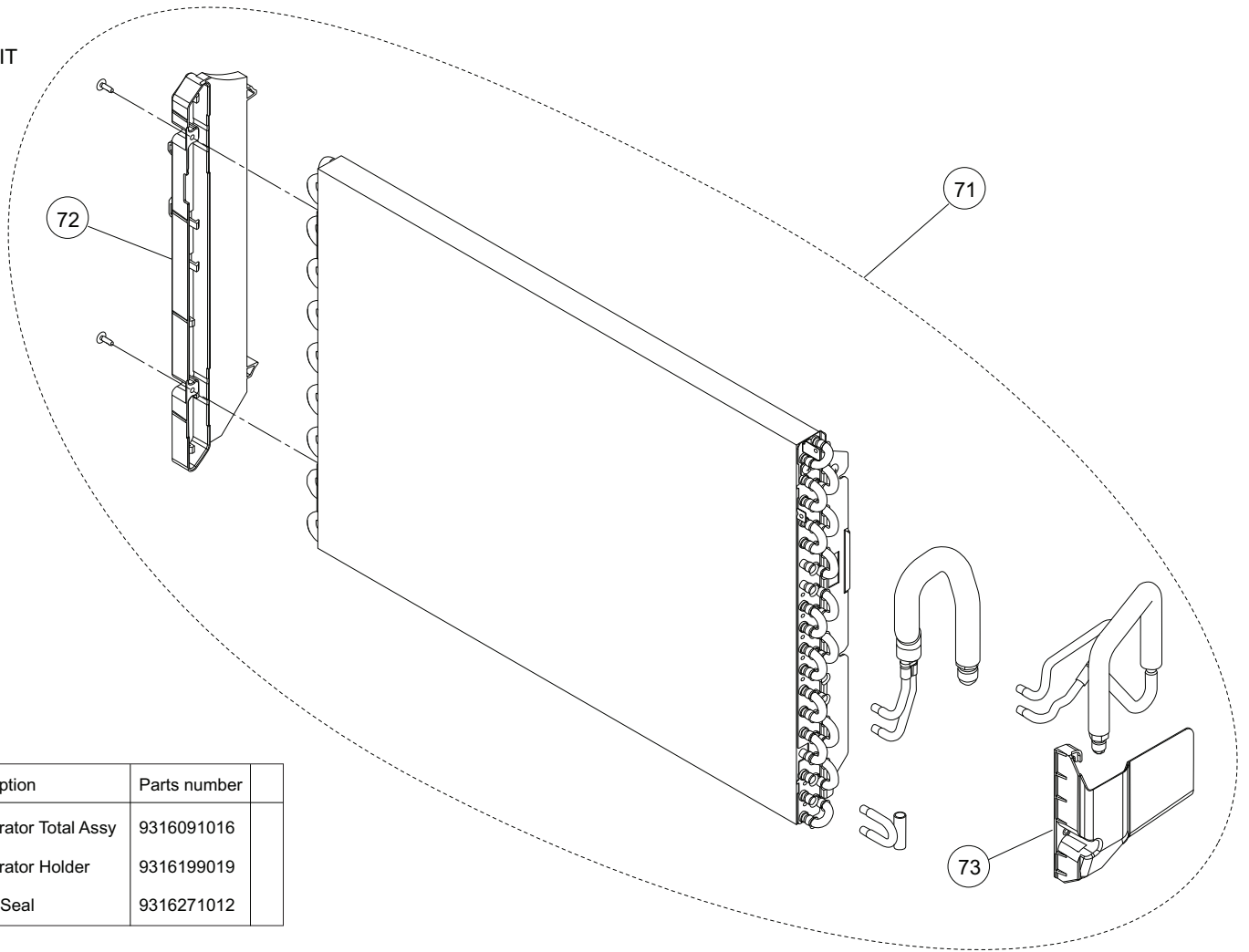

Ref	Description	Parts number
71	Evaporator Total Assy	9316091016
72	Evaporator Holder	9316199019
73	Water Seal	9316271012

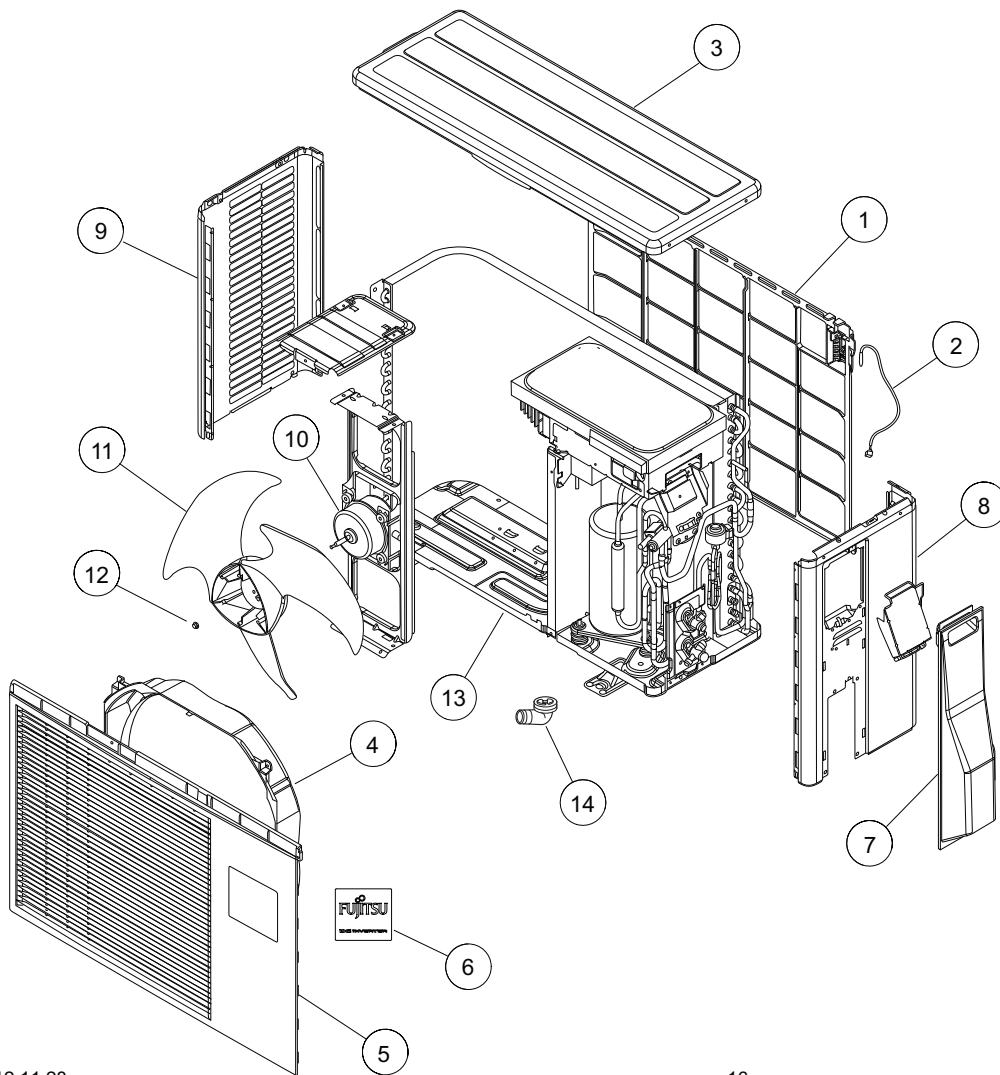

PARTS

OUTDOOR UNIT

Ref	Description	Parts number
1	Protective Net	9313941031
2	Outdoor Thermistor	9900544010
3	Top Panel Assy	9313988029
4	Fan Ring	9313807016
5	Front Panel	9313806026
6	Rear Emblem	9319151007
7	Switch Cover	9310979020
8	Cabinet Right Assy	9313994082
9	Cabinet Left Assy	9313991012
10	Fan Motor	9602111015
11	Propeller Fan	9313808013
12	Nut with Washer	9304902003
13	Base Assy	9316885004
14	Drain Assy	9303029022



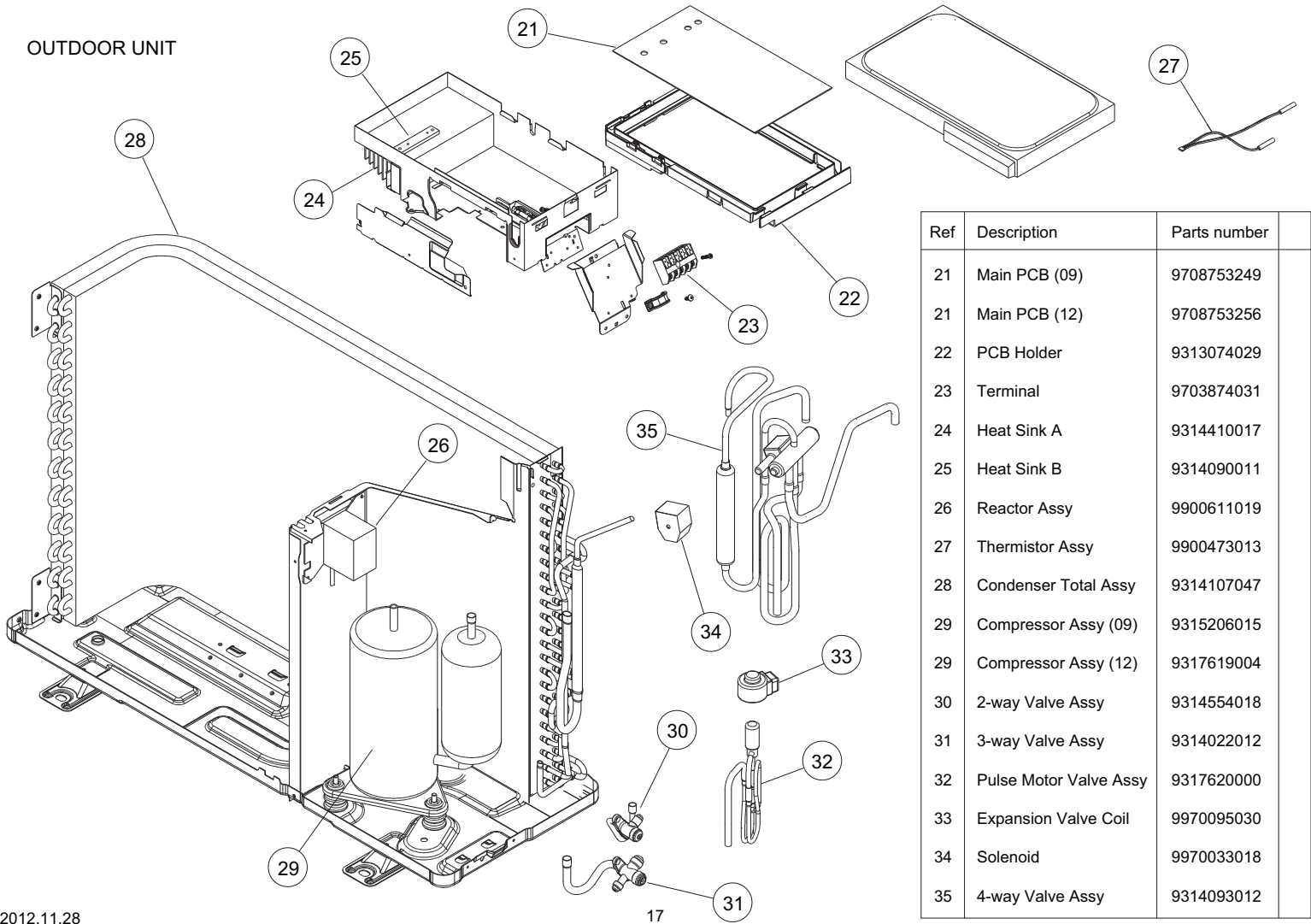

OUTDOOR UNIT

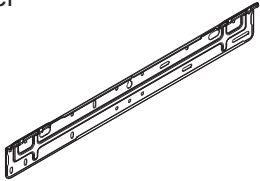

Ref	Description	Parts number
21	Main PCB (09)	9708753249
21	Main PCB (12)	9708753256
22	PCB Holder	9313074029
23	Terminal	9703874031
24	Heat Sink A	9314410017
25	Heat Sink B	9314090011
26	Reactor Assy	9900611019
27	Thermistor Assy	9900473013
28	Condenser Total Assy	9314107047
29	Compressor Assy (09)	9315206015
29	Compressor Assy (12)	9317619004
30	2-way Valve Assy	9314554018
31	3-way Valve Assy	9314022012
32	Pulse Motor Valve Assy	9317620000
33	Expansion Valve Coil	9970095030
34	Solenoid	9970033018
35	4-way Valve Assy	9314093012

ACCESSORIES

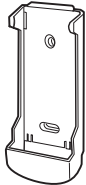
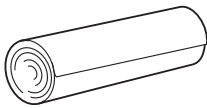
INDOOR UNIT

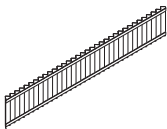
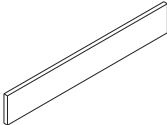
Name and Shape	Q'ty	Use	Part No.
Bracket panel 	1	For indoor unit installation	9316272019
Remote control 	1	Use for air conditioner operation	9379219006
Battery (penlight) 	2	For remote control	0600185541
Remote control holder 	1	Hold a remote control	9305642045
Cloth tape 	1	For indoor unit installation	9310519004
Tapping screw (big) (ϕ 4 x 25) 	9	For wall hook bracket and body installation	0700076046
Tapping screw (small) (ϕ 3 x 12) 	2	Install a remote control holder	0700019036
Electric filter 	1	With 2 sheets	9312153015
Ion deodorant filter 	1	With 2 sheets	9311925033

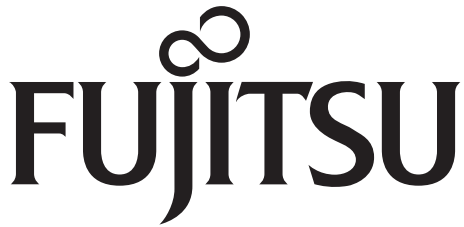

SPLIT TYPE
ROOM AIR CONDITIONER
FLOOR TYPE

SERVICE MANUAL

Indoor unit	Outdoor unit
AGYG14LVCA	AOYG14LVLA



CONTENTS

SPECIFICATIONS.....	1
DIMENSIONS.....	2
REFRIGERANT SYSTEM DIAGRAM.....	3
CIRCUIT DIAGRAM.....	4
INDOOR PCB CIRCUIT DIAGRAM.....	5
OUTDOOR PCB CIRCUIT DIAGRAM.....	8
ERROR DETECTION.....	10
PARTS (INDOOR UNIT).....	11
PARTS (OUTDOOR UNIT).....	16
ACCESSORIES.....	18

SPECIFICATIONS

ELECTRICAL DATA

TYPE		Cool & heat inverter
INDOOR UNIT		AGYG14LVCA
OUTDOOR UNIT		AOYG14LVLA
COOLING CAPACITY		4.20 kW
HEATING CAPACITY		5.20 kW
POWER SOURCE		230 V
FREQUENCY		50 Hz
RUNNING CURRENT	Cooling	5.2 A
	Heating	6.4 A
INPUT WATTS	Cooling	1.14 kW
	Heating	1.44 kW
E.E.R.	Cooling	3.68 kW/kW
COP	Heating	3.61 kW/kW
MOISTURE REMOVAL		2.1 L/hr
AIR CIRCULATION HIGH	Cooling	650 m ³ /hr
	Heating	650 m ³ /hr
MAXIMUM CURRENT	Cooling	9.0 A
	Heating	13.5 A

FAN MOTOR

POWER SOURCE		230 V
INDOOR UNIT cooling (upper fan / lower fan)	High	1,330 / 1,120 r.p.m.
	Medium	1,100 / 930 r.p.m.
	Low	890 / 750 r.p.m.
	Quiet	660 / 560 r.p.m.
INDOOR UNIT heating (upper fan / lower fan)	High	1,330 / 1,120 r.p.m.
	Medium	1,100 / 930 r.p.m.
	Low	860 / 730 r.p.m.
	Quiet	660 / 560 r.p.m.
OUTDOOR UNIT Cooling		820 r.p.m.
OUTDOOR UNIT Heating		750 r.p.m.

NOISE LEVEL

INDOOR UNIT Cooling	High	44 dB
	Medium	38 dB
	Low	31 dB
	Quiet	22 dB
INDOOR UNIT Heating	High	43 dB
	Medium	37 dB
	Low	29 dB
	Quiet	22 dB
OUTDOOR UNIT Cooling		50 dB
OUTDOOR UNIT Heating		50 dB

COMPRESSOR AND REFRIGERANT

COMPRESSOR TYPE		Hermetic type, 4 pole, Rotary
DISCRIMINATION		DA130A1F-25F
WEIGHT (with oil)		9.5 kg
PRECHARGED REFRIGERANT		1,150 g
FULL CHARGE	Pipe length 15 m	1,150 g
	20 m	1,250 g
ADDITIONAL CHARGE		20 g/m
MAXIMUM PIPING HEIGHT		15 m
REFRIGERANT TYPE		R410A

DIMENSIONS

INDOOR UNIT	H x W x D	600 x 740 x 200 mm
OUTDOOR UNIT	H x W x D	578 x 790 x 300 mm

WEIGHT

INDOOR UNIT	Net / Shipping	14 kg / 17 kg
OUTDOOR UNIT	Net / Shipping	40 kg / 44 kg

DIMENSIONS

unit : mm

INDOOR UNIT

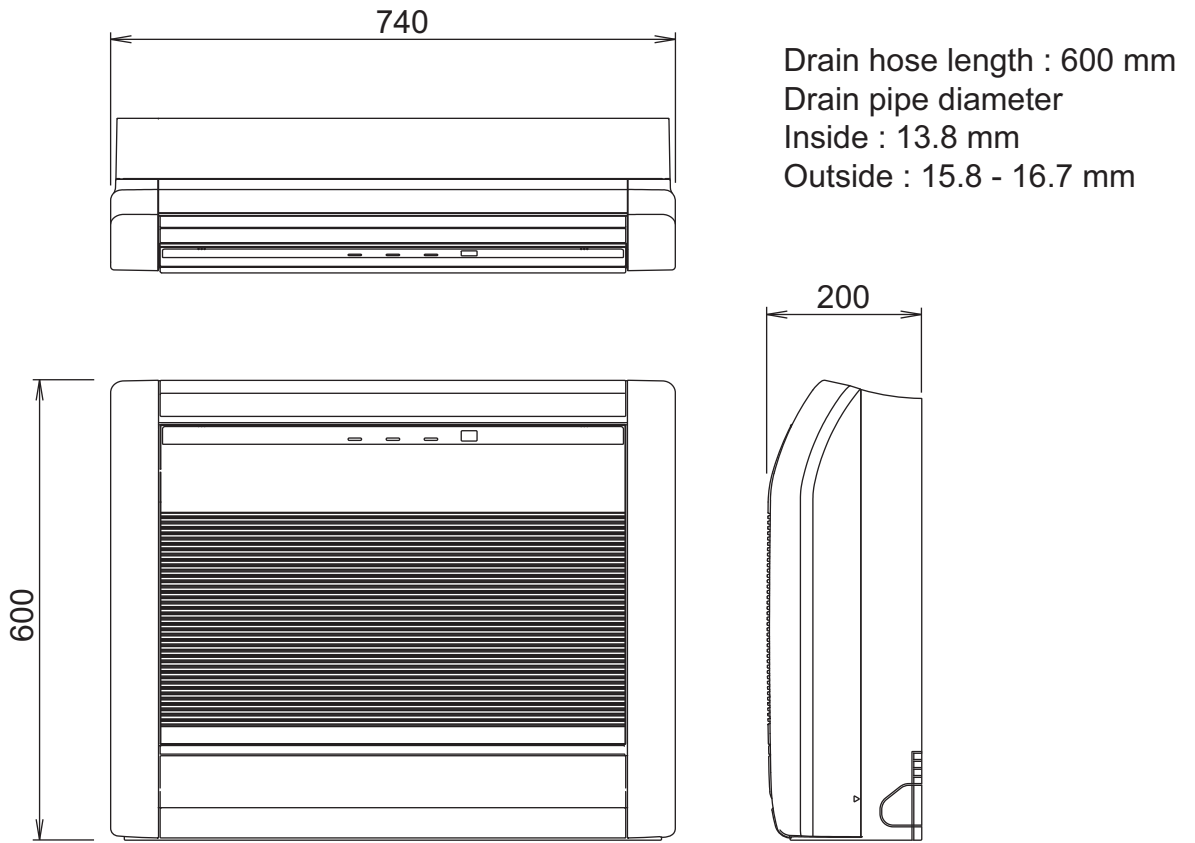

OUTDOOR UNIT

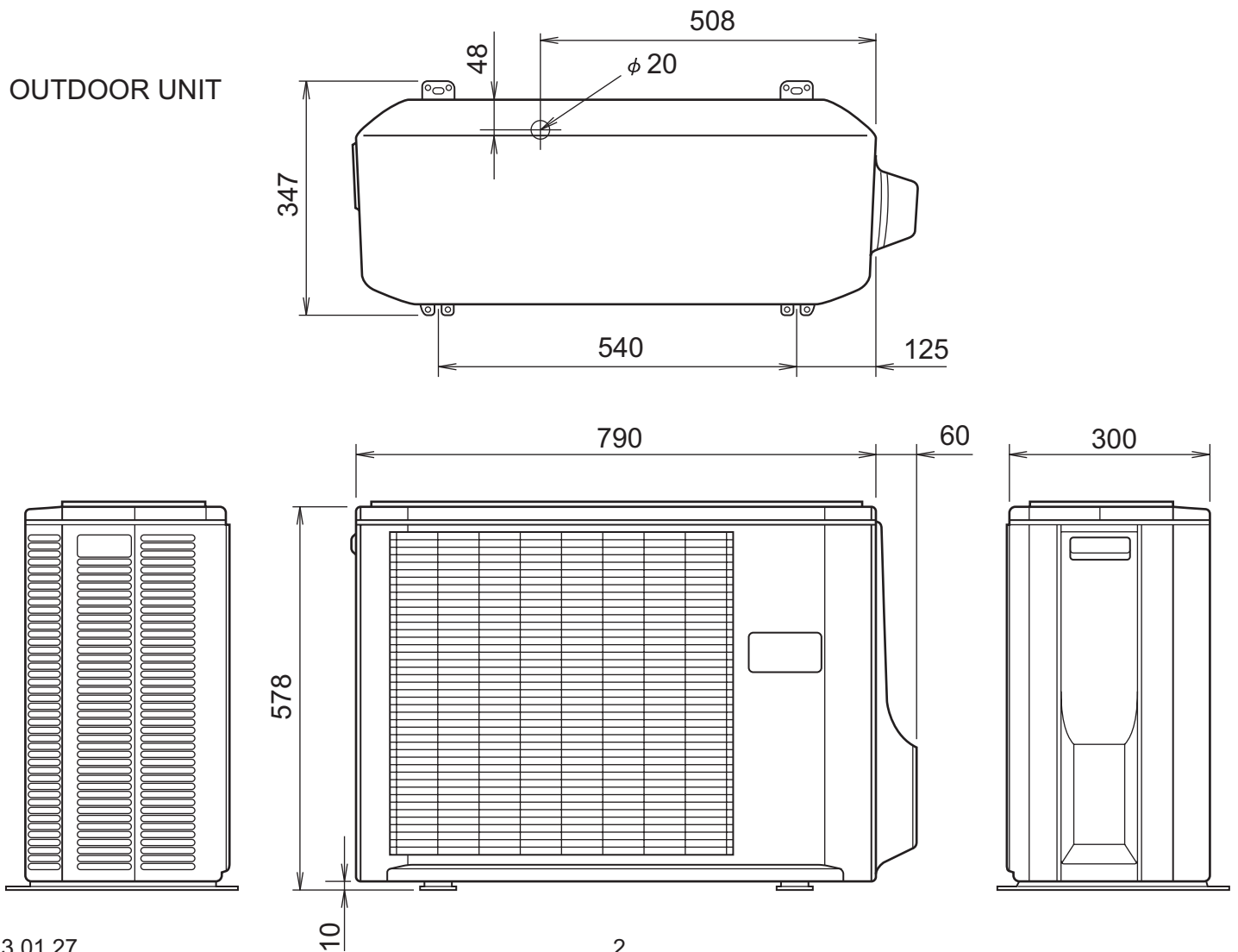

REFRIGERANT SYSTEM DIAGRAM

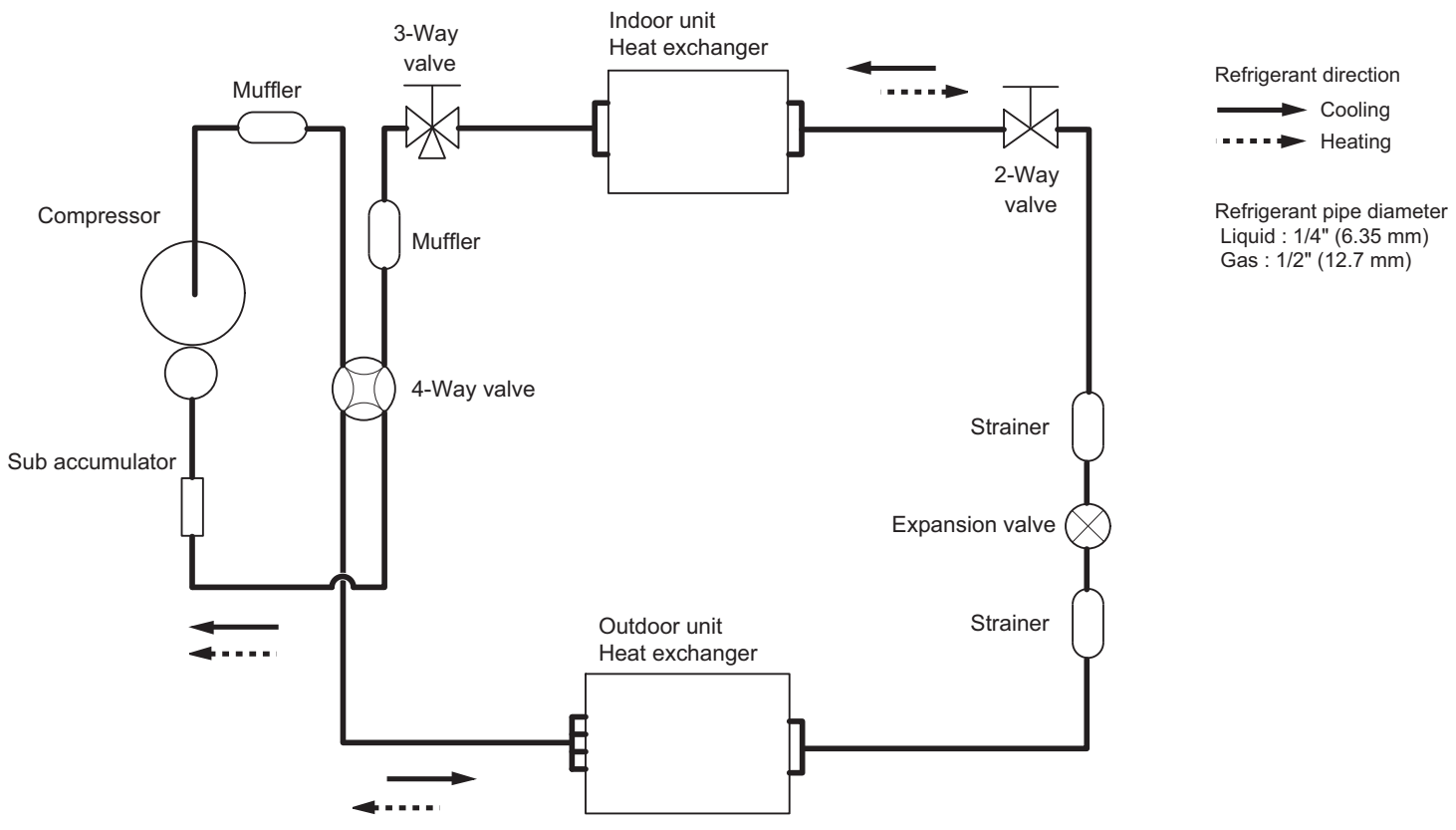

CIRCUIT DIAGRAM

INDOOR UNIT

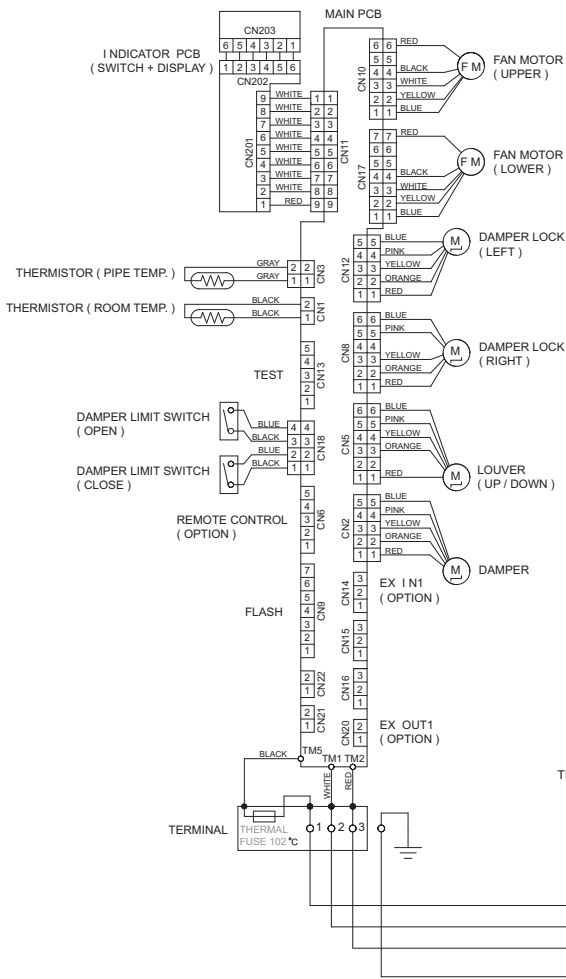

OUTDOOR UNIT

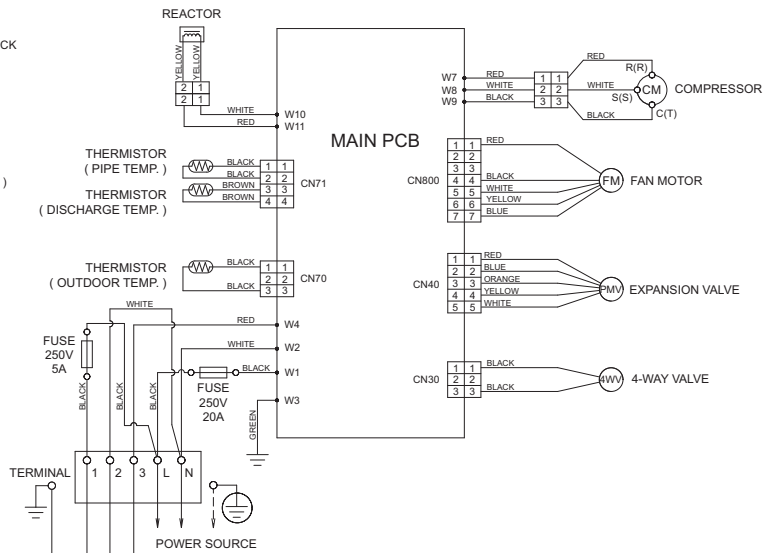

INDOOR PCB CIRCUIT DIAGRAM

CONTROL UNIT
EZ-01218HSE

INDICATOR PCB
(SWITCH + DISPLAY)
K06DD-0801HSE-F0

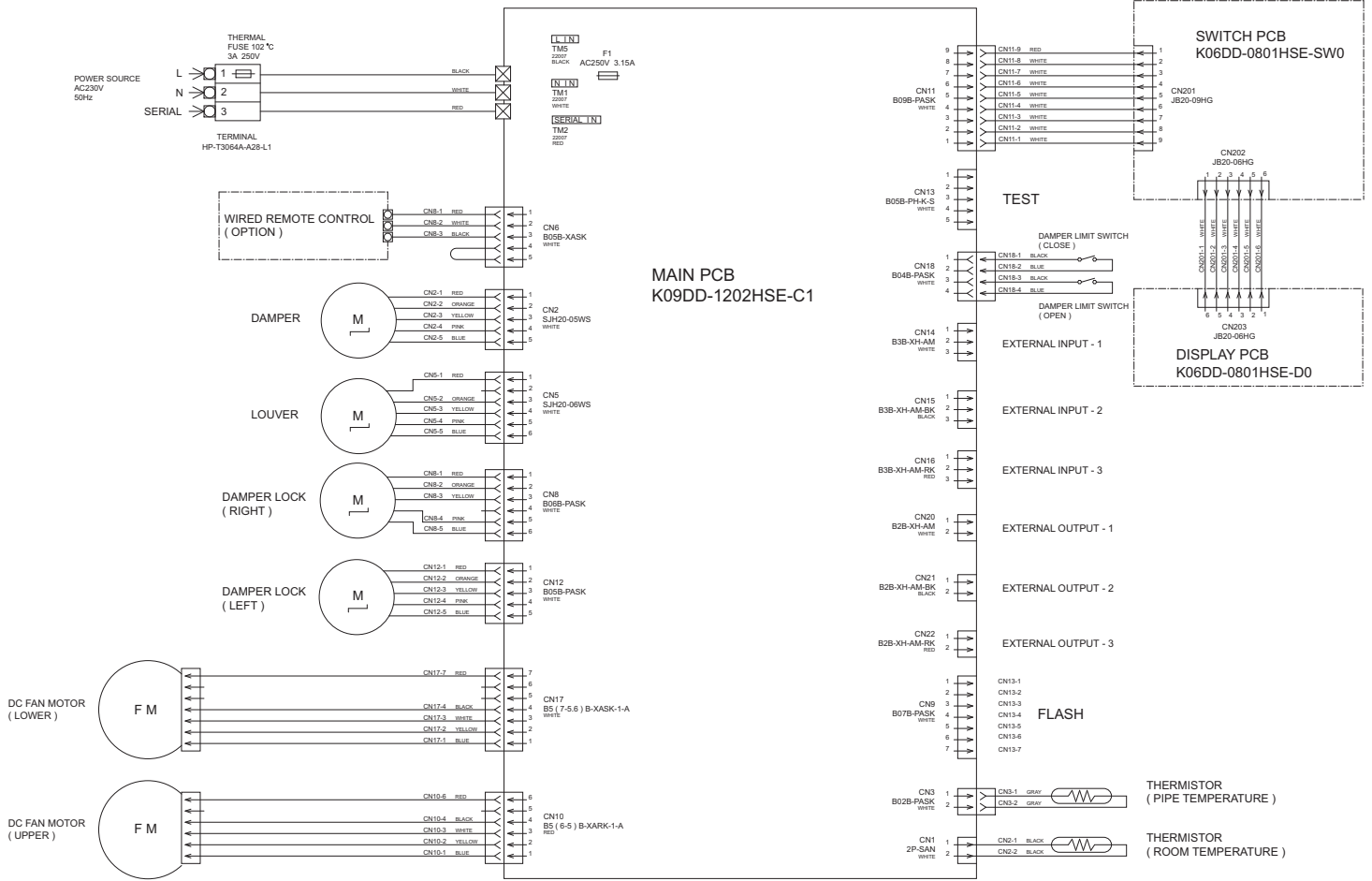

INDOOR UNIT
MAIN PCB
K09DD-1202HSE-C1

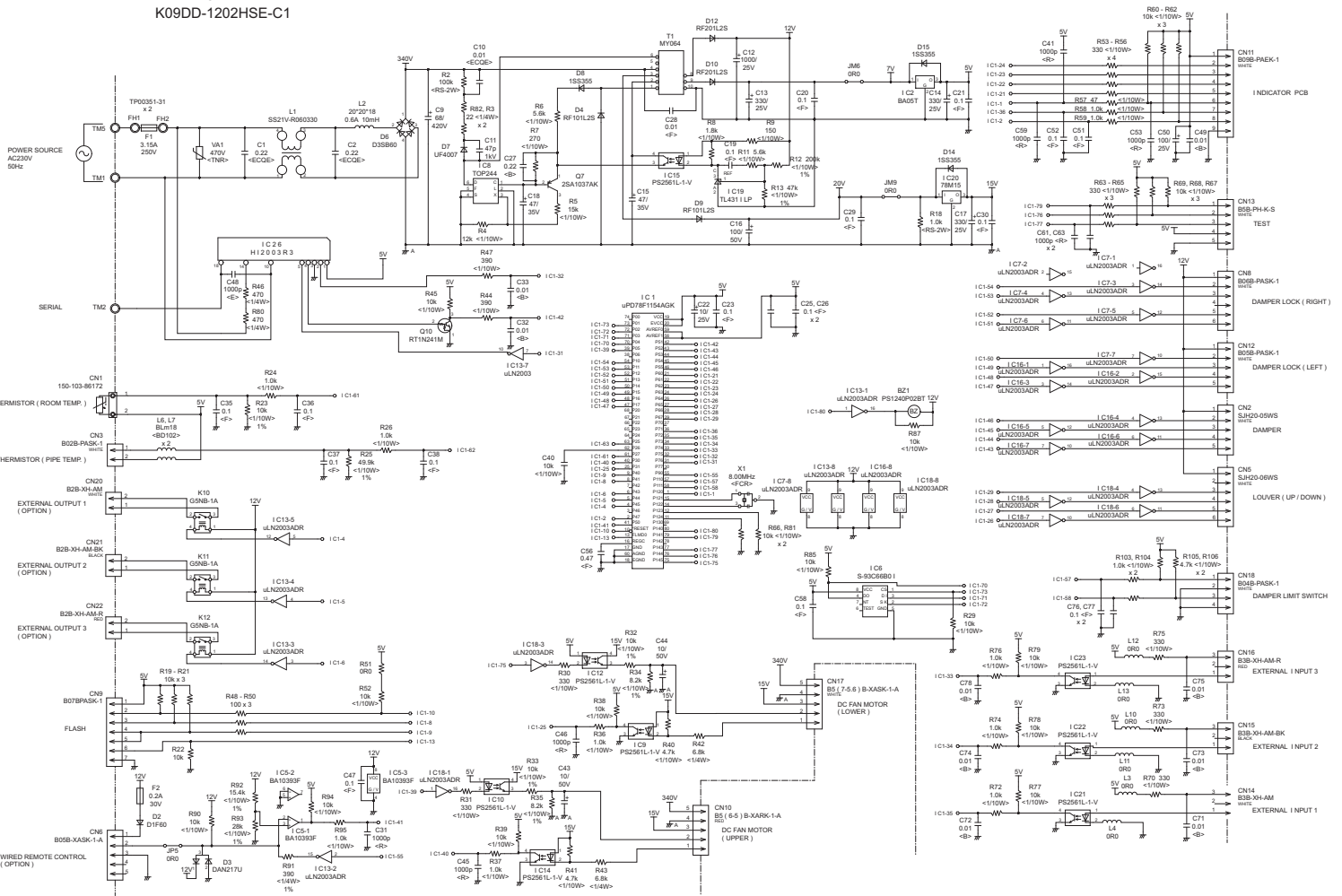

INDOOR UNIT
 INDICATOR PCB
 K06DD-0801HSE-F0

K06DD-0801HSE-D0

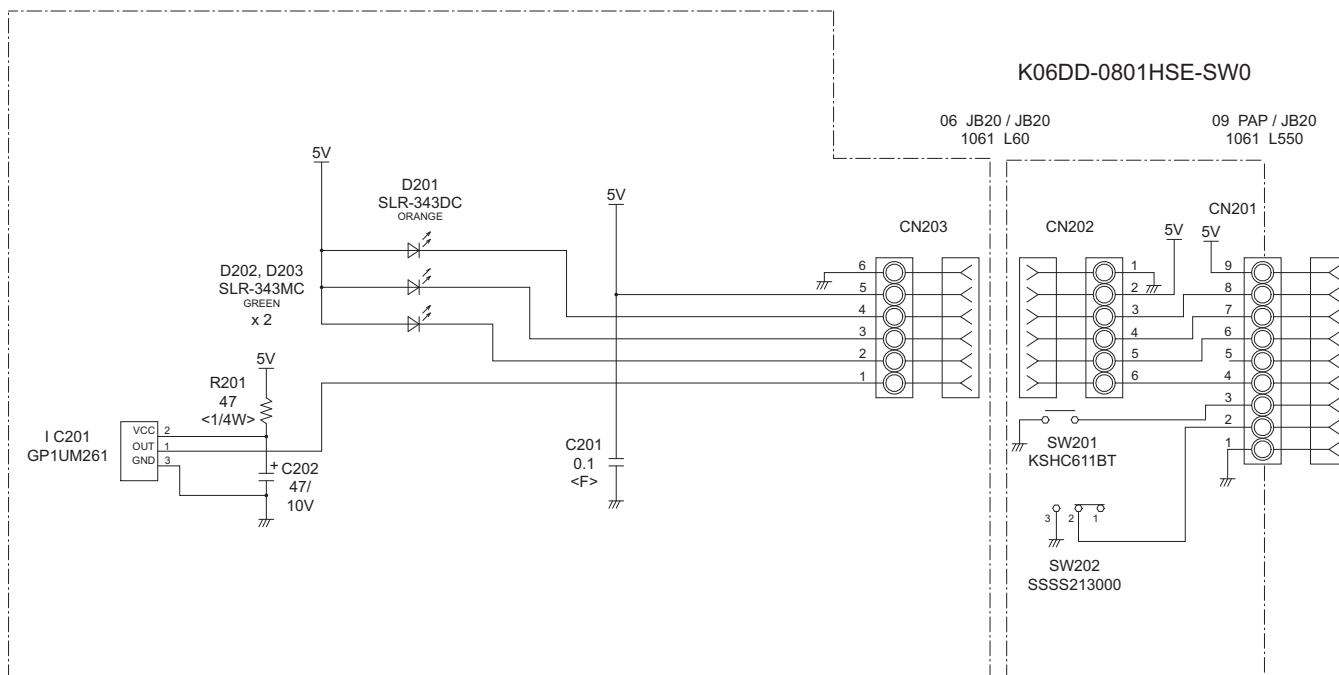

OUTDOOR PCB CIRCUIT DIAGRAM

INVERTER ASSEMBLY EZ-01215HUE

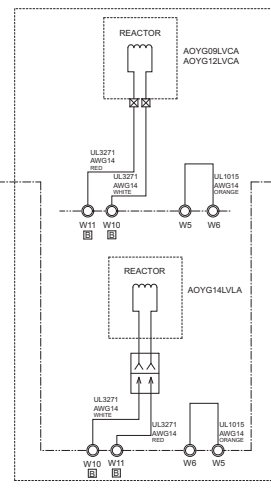
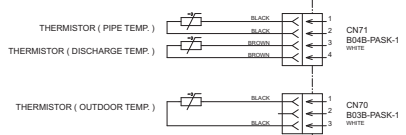
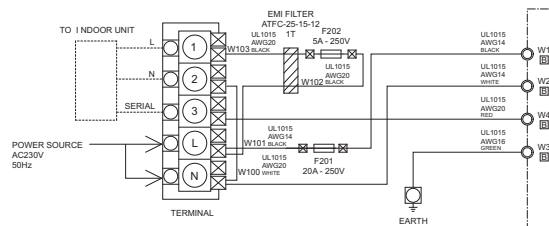

MAIN PCB K10CT-1204HUE-C1

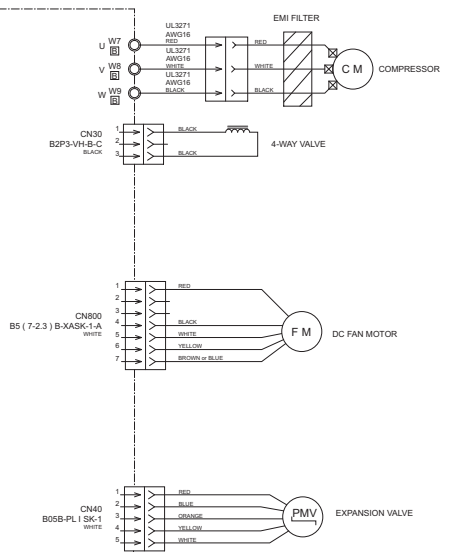

OUTDOOR UNIT
MAIN PCB
K10CT-1204HUE-C1

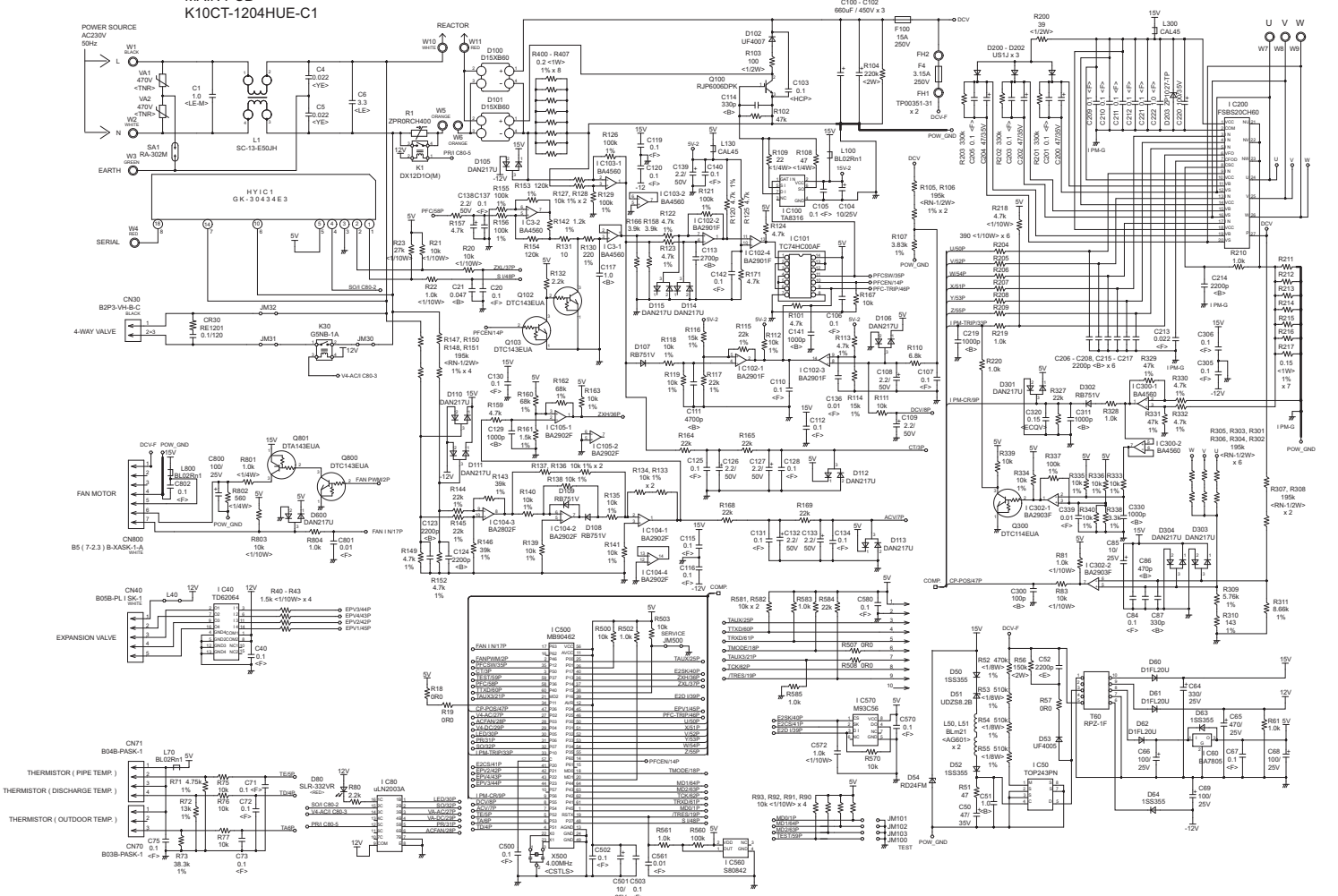

ERROR DETECTION

If you use a wireless remote control, the lamp on the photo detector unit will output error codes by way of blinking patterns.
 If you use a wired remote control, error codes will appear on the remote control display.
 See the lamp blinking patterns and error codes in the table.
 An error display is displayed only during operation.

Indoor unit display

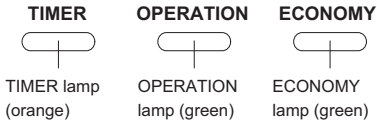
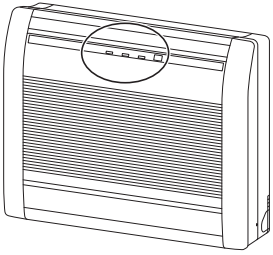

Wired remote control display (Option)

If an error occurs, the following display will be shown. ("Er" will appear in the set room temperature display.)

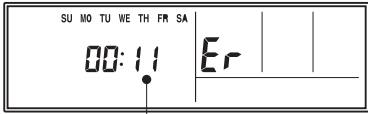

● : 0.5s on / 0.5s off
 ◇ : 0.1s on / 0.1s off
 () : Number of flash

Indoor unit lamps			Wired remote control	Description
OPERATION (green)	TIMER (orange)	ECONOMY (green)		
●(1)	●(1)	◇	11	Serial communication error
●(1)	●(2)	◇	12	Wired remote controller communication error
●(1)	●(5)	◇	15	Check run unfinished
●(2)	●(1)	◇	21	Unit number or Refrigerant circuit address setting error [Simultaneous Multi]
●(2)	●(2)	◇	22	Indoor unit capacity error
●(2)	●(3)	◇	23	Combination error
●(2)	●(4)	◇	24	• Connection unit number error (indoor secondary unit) [Simultaneous Multi] • Connection unit number error (indoor unit or branch unit) [Flexible Multi]
●(2)	●(7)	◇	27	Primary unit, secondary unit set-up error [Simultaneous Multi]
●(3)	●(2)	◇	32	Indoor unit PCB model information error
●(3)	●(5)	◇	35	Manual auto switch error
●(4)	●(1)	◇	41	Inlet air temp. sensor error
●(4)	●(2)	◇	42	Indoor unit Heat Ex. Middle temp. sensor error
●(5)	●(1)	◇	51	Indoor unit fan motor error
●(5)	●(3)	◇	53	Drain pump error
●(5)	●(7)	◇	57	Damper error
●(5)	●(15)	◇	5U	Indoor unit error
●(6)	●(2)	◇	62	Outdoor unit main PCB model information error or communication error
●(6)	●(3)	◇	63	Inverter error
●(6)	●(4)	◇	64	Active Hter error, PFC circuit error
●(6)	●(5)	◇	65	Trip terminal L error

Indoor unit lamps			Wired remote control	Description
OPERATION (green)	TIMER (orange)	ECONOMY (green)		
●(6)	●(10)	◇	6A	Display PCB microcomputers communication error
●(7)	●(1)	◇	71	Discharge temp. sensor error
●(7)	●(2)	◇	72	Compressor temp. sensor error
●(7)	●(3)	◇	73	Outdoor unit Heat Ex. liquid temp. sensor error
●(7)	●(4)	◇	74	Outdoor temp. sensor error
●(7)	●(5)	◇	75	Suction Gas temp. sensor error
●(7)	●(6)	◇	76	• 2-way valve temp. sensor error • 3-way valve temp. sensor error
●(7)	●(7)	◇	77	Heat sink temp. sensor error
●(8)	●(2)	◇	82	• Sub-cool Heat Ex. gas inlet temp. sensor error • Sub-cool Heat Ex. gas outlet temp. sensor error
●(8)	●(3)	◇	83	Liquid pipe temp. sensor error
●(8)	●(4)	◇	84	Current sensor error
●(8)	●(6)	◇	86	• Discharge pressure sensor error • Suction pressure sensor error • High pressure switch error
●(9)	●(4)	◇	94	Trip detection
●(9)	●(5)	◇	95	Compressor rotor position detection error (permanent stop)
●(9)	●(7)	◇	97	Outdoor unit fan motor error
●(9)	●(9)	◇	99	4-way valve error
●(10)	●(1)	◇	A1	Discharge temp. error
●(10)	●(3)	◇	A3	Compressor temp. error
●(10)	●(4)	◇	A4	High pressure error
●(10)	●(5)	◇	A5	Low pressure error
●(13)	●(2)	◇	J2	Branch boxes error [Flexible Multi]

PARTS

INDOOR UNIT

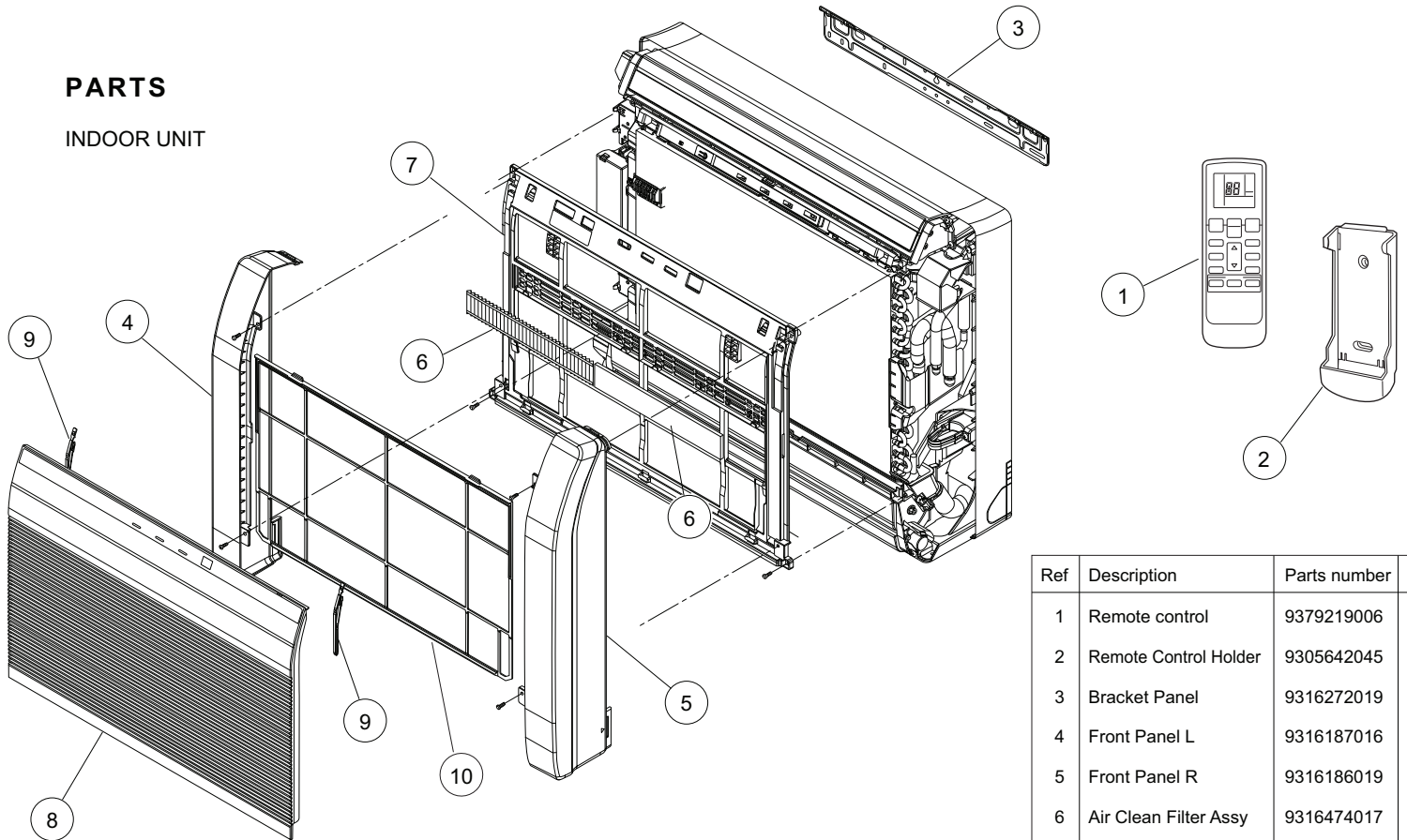

Ref	Description	Parts number
1	Remote control	9379219006
2	Remote Control Holder	9305642045
3	Bracket Panel	9316272019
4	Front Panel L	9316187016
5	Front Panel R	9316186019
6	Air Clean Filter Assy	9316474017
7	Front Panel	9316185012
8	Intake Grille Assy	9316418059
9	Rope Assy	9316458017
10	Air Filter	9316189010

INDOOR UNIT

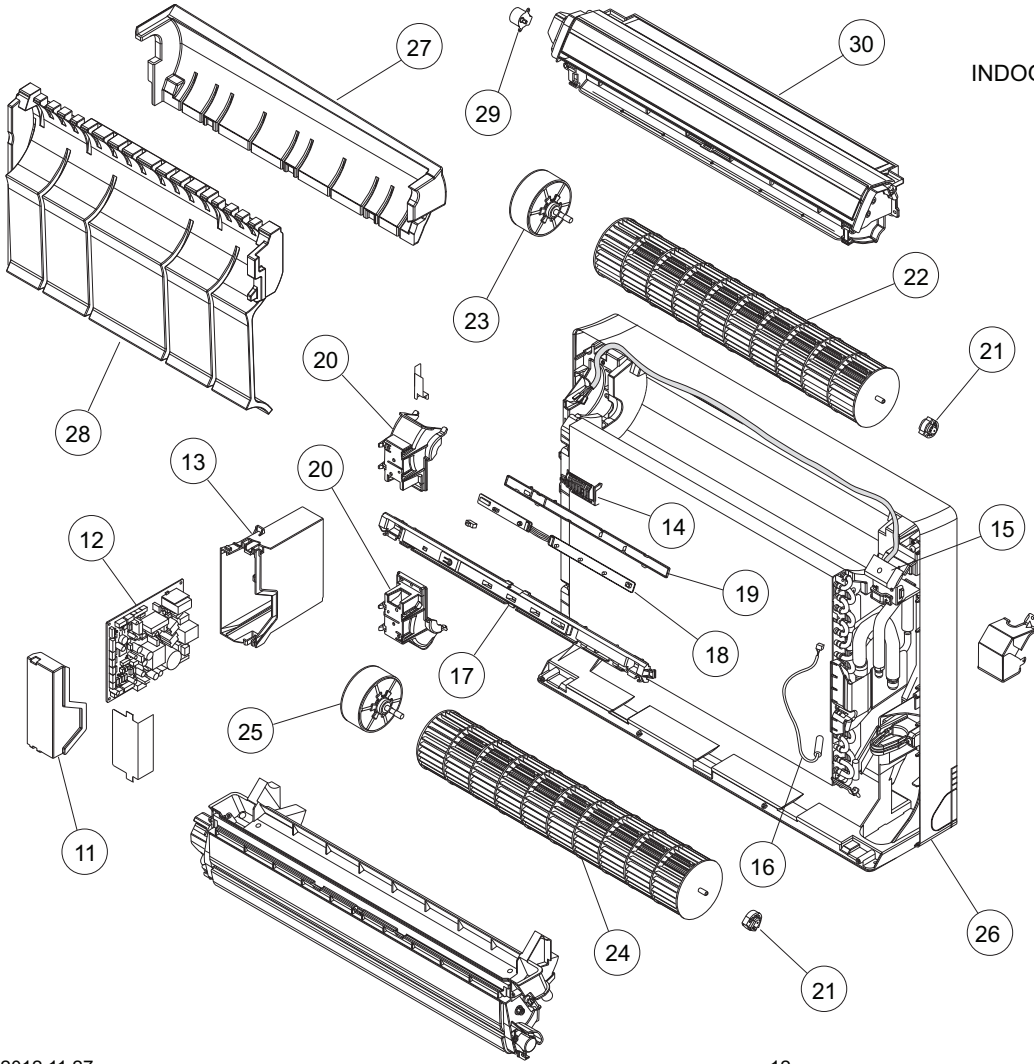

Ref	Description	Parts number
11	Control Cover	9316201019
12	Main PCB	9708532097
13	Control Box	9316200012
14	Thermistor Holder	9316192010
15	Terminal	9900385026
16	Pipe Thermistor	9900425012
17	Display Case	9316194014
18	Indicator PCB	9707571042
19	Display Cover	9316191013
20	Motor Holder	9316195011
21	Bearing C Assy	9306628017
22	Crossflow Fan Assy	9312004034
23	Fan Motor, MFD-14TXN	9602850006
24	Crossflow Fan B Assy	9316309012
25	Fan Motor, MFD-14SXX	9602851003
26	Base	9316193017
27	Base Cover A	9316197015
28	Base Cover B	9316373013
29	Step Motor (Up / down)	9900384043
30	Casing Assy	9316411012

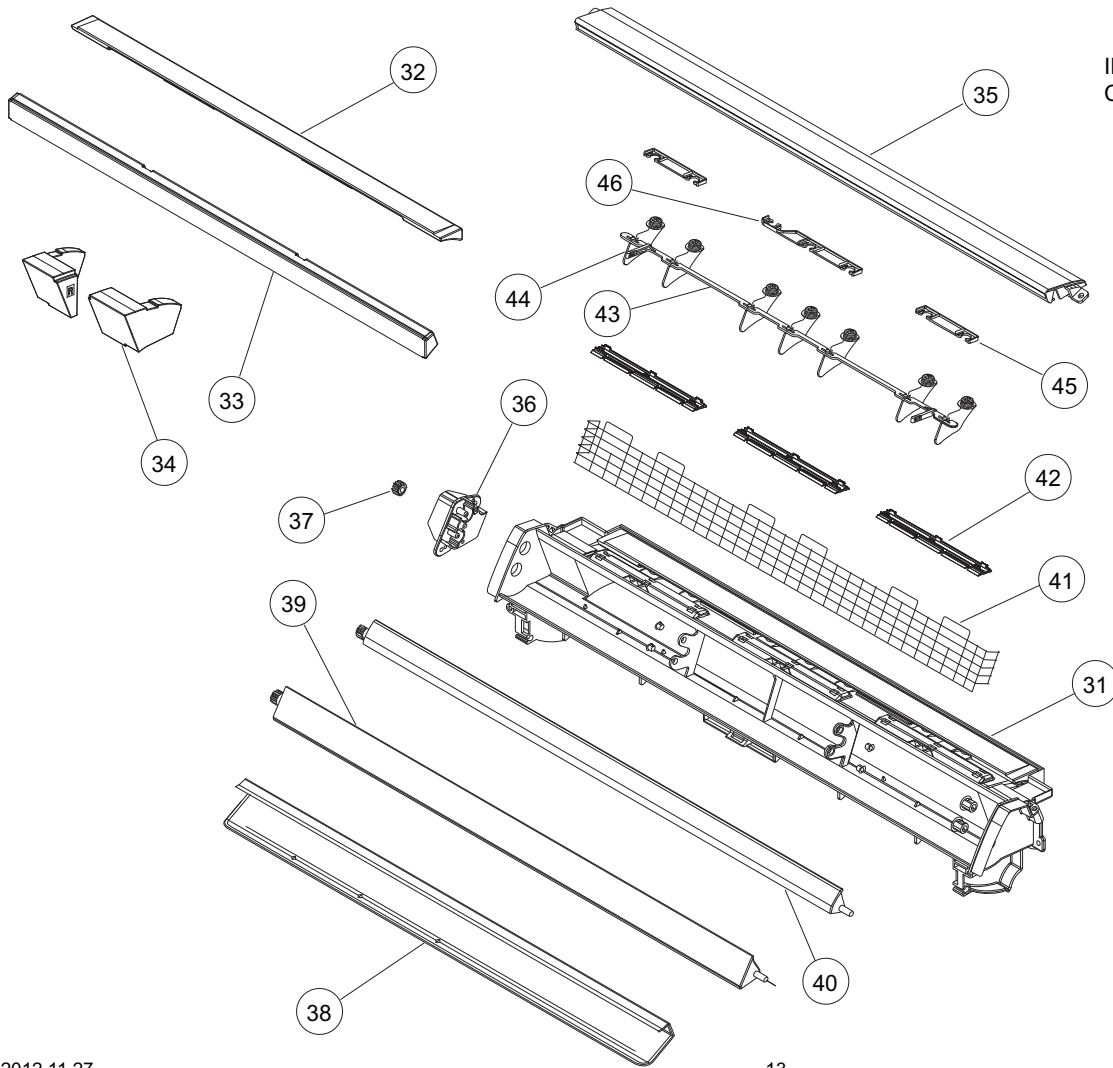

INDOOR UNIT
Casing assy

Ref	Description	Parts number
31	Casing	9316204010
32	Casing Cover B	9316273016
33	Casing Cover F	9316308015
34	Casing Cover LR	9316310018
35	Top Cover	9316207011
36	Gear Case	9316213012
37	Gear A	9309994003
38	Reinforcement	9316378018
39	Louver Z (Lower)	9316206014
40	Louver U (Upper)	9316205017
41	Fan Guard	9316211018
42	Guard Holder	9316210011
43	Joint U	9316209015
44	R and L Louver U	9316208018
45	Spacer C	9315281012
46	Spacer D	9315282019

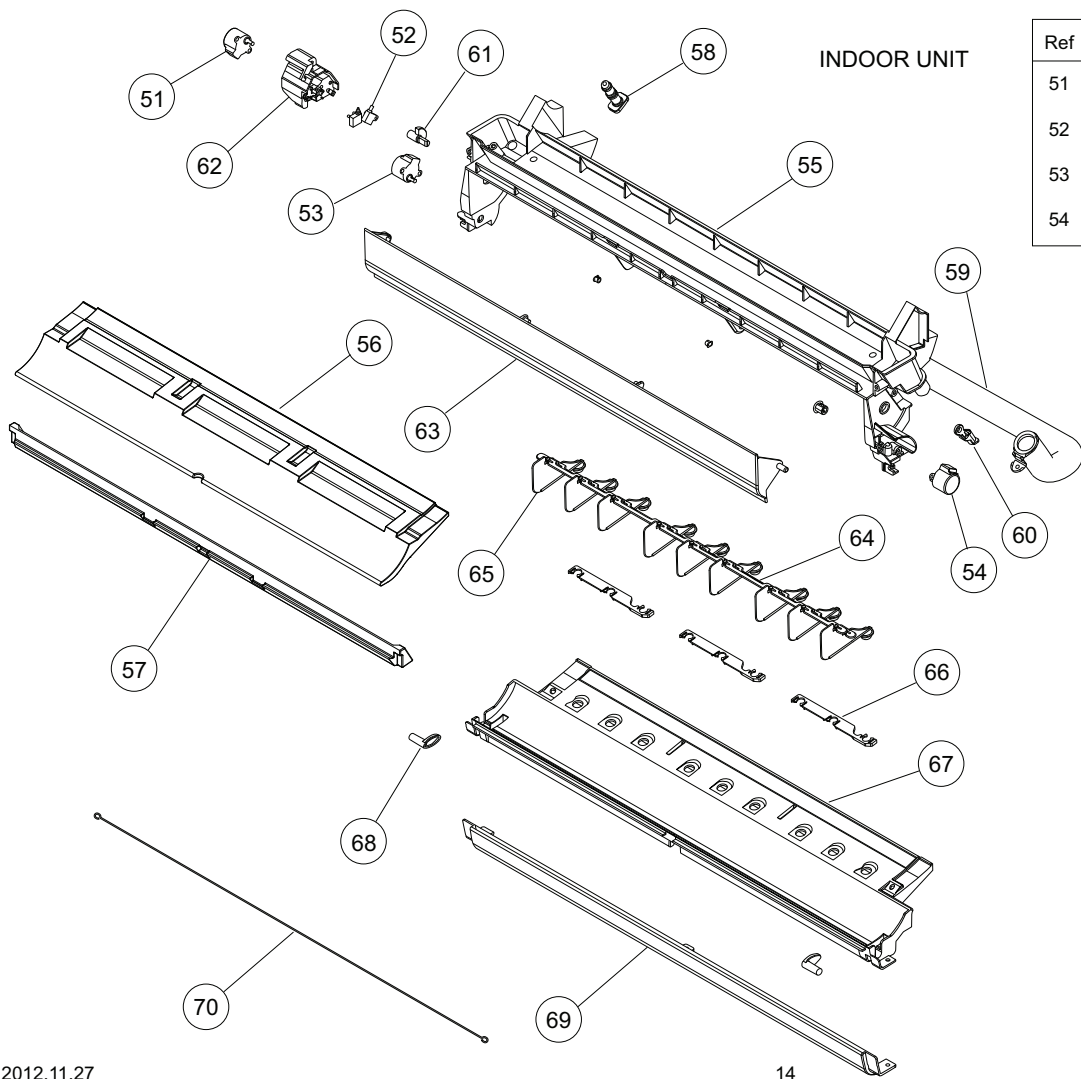

Ref	Description	Parts number
51	Motor Step (Damper)	9900384050
52	Micro Switch (Limit Switch)	9900424015
53	Motor Step (Damper Lock Left)	9900384067
54	Step Motor (Damper Lock Right)	9900384074

Drain Pan Assy

Ref	Description	Parts number
--	Drain Pan Assy	9316412019
55	Drain Pan U	9316214019
56	Drain Pan Cover B	9316386013
57	Drain Pan Cover F	9316274013
58	Drain Cap	9316177017
59	Drain Hose Assy	9314147029
60	Drain Holder	9316384019
61	Key Top	9316218017
62	Limit Switch Cover	9316217010
63	Damper	9316216013
64	Joint Z	9316335011
65	R and L Louver Z	9316334014
66	Spacer D	9315282019
67	Drain Pan Z	9316215016
68	Stopper	9316219014
69	Under Cover	9316374010
70	Fan Guard Z	9316918009

INDOOR UNIT

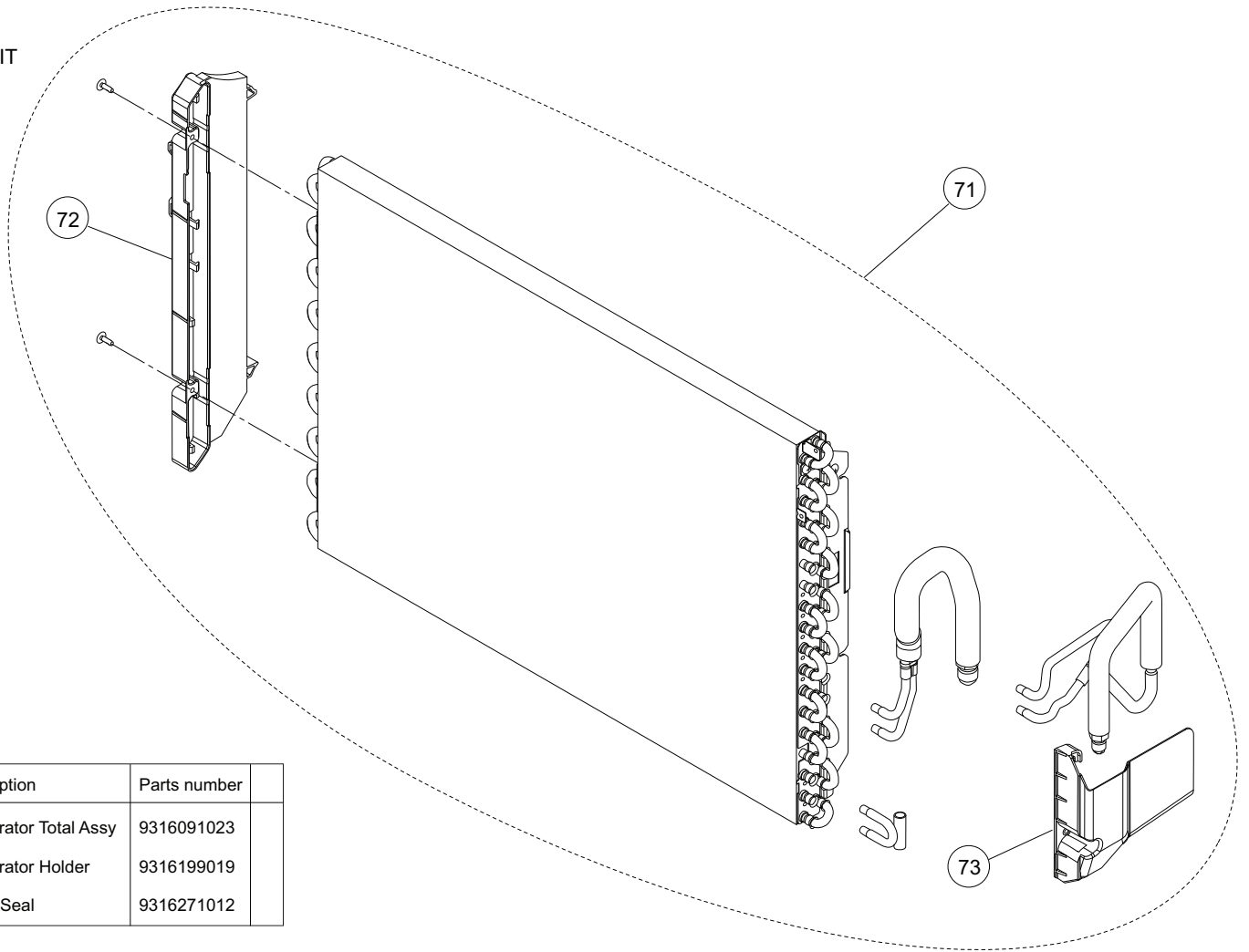

Ref	Description	Parts number
71	Evaporator Total Assy	9316091023
72	Evaporator Holder	9316199019
73	Water Seal	9316271012

PARTS

OUTDOOR UNIT

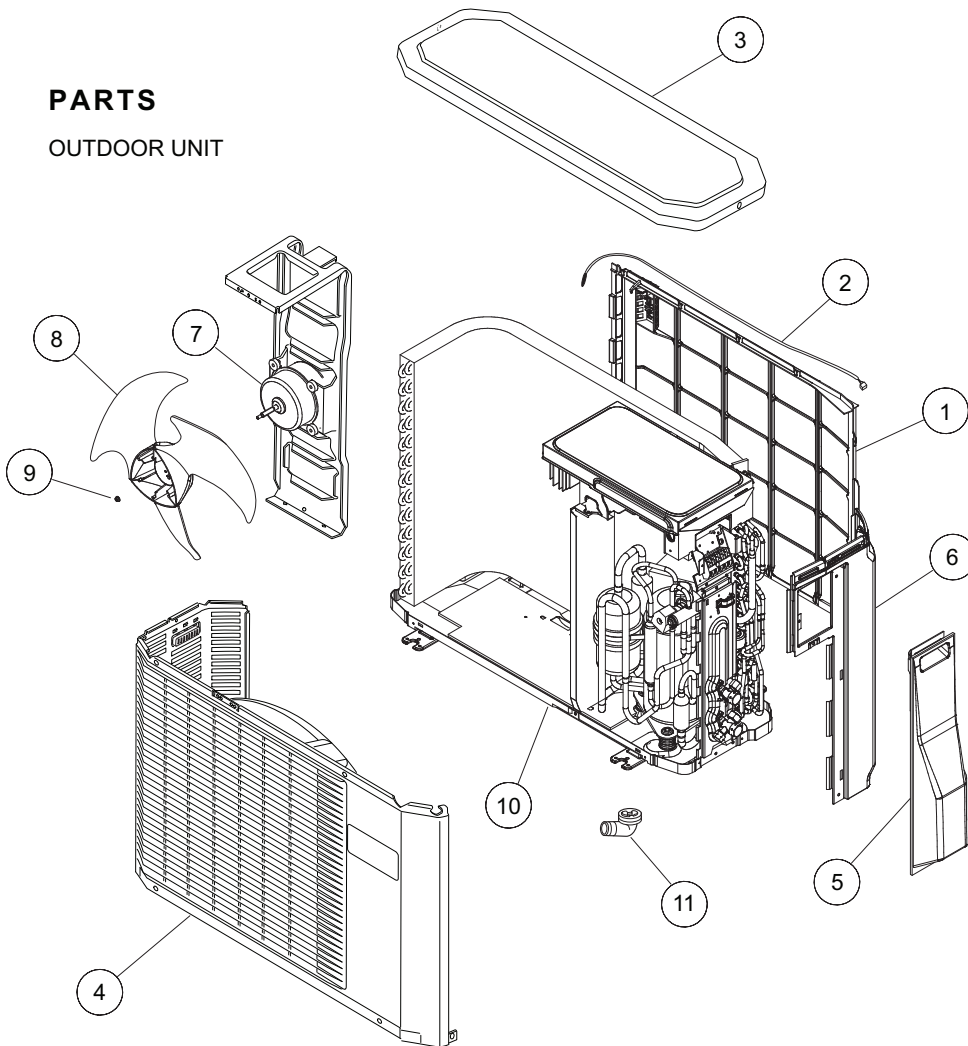

Ref	Description	Parts number
1	Protective Net	9315319036
2	Outdoor Thermistor	9900210045
3	Top Panel Assy	9309230057
4	Cabinet Assy	9312799404
5	Switch Cover Assy	9309237025
6	Cabinet Right Assy	9309236011
7	Fan Motor	9601725015
8	Propeller Fan	9309909014
9	Nut with Washer	9304902003
10	Base Assy	9308869081
11	Drain Assy	9303029015



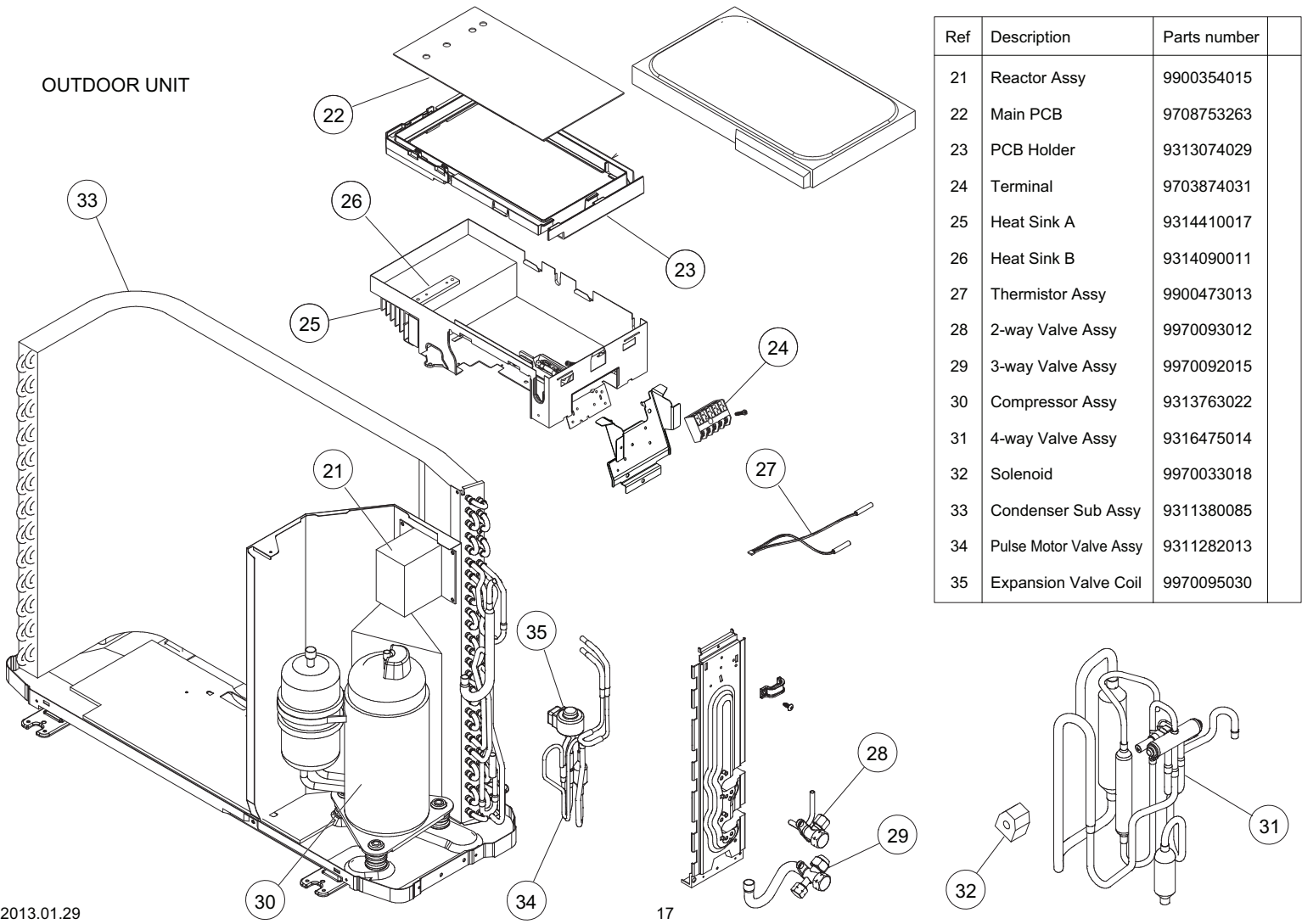

OUTDOOR UNIT

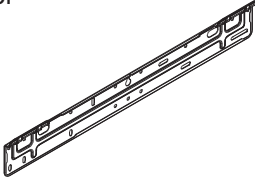

Ref	Description	Parts number
21	Reactor Assy	9900354015
22	Main PCB	9708753263
23	PCB Holder	9313074029
24	Terminal	9703874031
25	Heat Sink A	9314410017
26	Heat Sink B	9314090011
27	Thermistor Assy	9900473013
28	2-way Valve Assy	9970093012
29	3-way Valve Assy	9970092015
30	Compressor Assy	9313763022
31	4-way Valve Assy	9316475014
32	Solenoid	9970033018
33	Condenser Sub Assy	9311380085
34	Pulse Motor Valve Assy	9311282013
35	Expansion Valve Coil	9970095030

ACCESSORIES

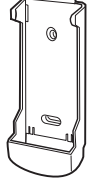
INDOOR UNIT

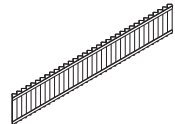
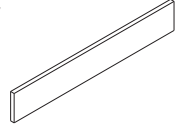
Name and Shape	Q'ty	Use	Part No.
Bracket panel 	1	For indoor unit installation	9316272019
Remote control 	1	Use for air conditioner operation	9379219006
Battery (penlight) 	2	For remote control	0600185541
Remote control holder 	1	Hold a remote control	9305642045
Cloth tape 	1	For indoor unit installation	9310519004
Tapping screw (big) ($\phi 4 \times 25$) 	9	For wall hook bracket and body installation	0700076046
Tpping screw (small) ($\phi 3 \times 12$) 	2	Install a remote control holder	0700019036
Electric filter 	1	With 2 sheets	UTR-FC03-2
Ion deodrant filter 	1	With 2 sheets	UTR-FC03-3

1211G4131