

**BINKS®**

# AIRLESS 75M SPRAY GUN 7500 PSI

(0811-7500-4)

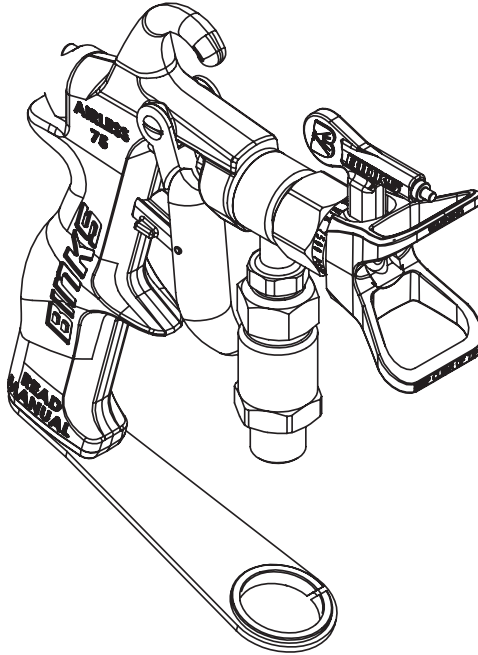

The following instructions provide the necessary information for the proper operation and preventive maintenance of the Binks Airless 75M Spray Gun. Please read and understand all information in this document in order to get the maximum performance from your new Airless 75M spray gun.

## **IMPORTANT! DO NOT DESTROY**

It is the customer's responsibility to have all operators and service personnel read and understand this manual.

Contact your local Binks representative for additional copies of this manual.

**READ ALL INSTRUCTIONS BEFORE OPERATING THIS BINKS PRODUCT.**

In this part sheet, the words **WARNING**, **CAUTION** and **NOTE** are used to emphasize important safety information as follows:

**⚠ WARNING**

**Hazards or unsafe practices which could result in severe personal injury, death or substantial property damage.**

**⚠ CAUTION**

**Hazards or unsafe practices which could result in minor personal injury, product or property damage.**

**NOTE**

**Important installation, operation or maintenance information.**

**Read the following warnings before using this equipment.**



**READ THE MANUAL**

Before operating finishing equipment, read and understand all safety, operation and maintenance information provided in the operation manual.



**WEAR SAFETY GLASSES**

Failure to wear safety glasses with side shields could result in serious eye injury or blindness.



**DE-ENERGIZE, DEPRESSURIZE, DISCONNECT AND LOCK OUT ALL POWER SOURCES DURING MAINTENANCE**

Failure to De-energize, disconnect and lock out all power supplies before performing equipment maintenance could cause serious injury or death.



**OPERATOR TRAINING**

All personnel must be trained before operating finishing equipment.



**EQUIPMENT MISUSE HAZARD**

Equipment misuse can cause the equipment to rupture, malfunction, or start unexpectedly and result in serious injury.



**KEEP EQUIPMENT GUARDS IN PLACE**

Do not operate the equipment if the safety devices have been removed.

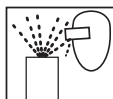

**PROJECTILE HAZARD**

You may be injured by venting liquids or gases that are released under pressure, or flying debris.



**PINCH POINT HAZARD**

Moving parts can crush and cut. Pinch points are basically any areas where there are moving parts.



**INSPECT THE EQUIPMENT DAILY**

Inspect the equipment for worn or broken parts on a daily basis. Do not operate the equipment if you are uncertain about its condition.



**NEVER MODIFY THE EQUIPMENT**

Do not modify the equipment unless the manufacturer provides written approval.



**KNOW WHERE AND HOW TO SHUT OFF THE EQUIPMENT IN CASE OF AN EMERGENCY**



**PRESSURE RELIEF PROCEDURE**

Always follow the pressure relief procedure in the equipment instruction manual.



**NOISE HAZARD**

You may be injured by loud noise. Hearing protection may be required when using this equipment.



**STATIC CHARGE**

Fluid may develop a static charge that must be dissipated through proper grounding of the equipment, objects to be sprayed and all other electrically conductive objects in the dispensing area. Improper grounding or sparks can cause a hazardous condition and result in fire, explosion or electric shock and other serious injury.



**FIRE AND EXPLOSION HAZARD**

Never use 1,1,1-trichloroethane, methylene chloride, other halogenated hydrocarbon solvents or fluids containing such solvents in equipment with aluminum wetted parts. Such use could result in a serious chemical reaction, with the possibility of explosion. Consult your fluid suppliers to ensure that the fluids being used are compatible with aluminum parts.



**PROP 65 WARNING**

WARNING: This product contains chemicals known to the State of California to cause cancer and birth defects or other reproductive harm.

**IT IS THE RESPONSIBILITY OF THE EMPLOYER TO PROVIDE THIS INFORMATION TO THE OPERATOR OF THE EQUIPMENT.**

**FOR FURTHER SAFETY INFORMATION REGARDING BINKS AND DEVILBISS EQUIPMENT, SEE THE GENERAL EQUIPMENT SAFETY BOOKLET (77-5300).**

## BINKS AIRLESS 75M SPRAY GUN 7500 PSI

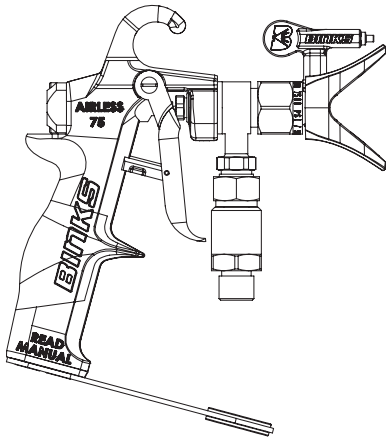

0811-7500-4

For trained, professional use only!

Maximum working pressure:  
7500 PSI – 517 BAR – 51.7 Mpa  
Model 0811-7500-4

**SAFETY, OPERATING AND  
MAINTENANCE  
INSTRUCTIONS INSIDE!!**

Read all warnings and  
operating information inside

**SAVE THIS MANUAL FOR FUTURE  
REFERENCE**

Contact your local Binks representative  
for additional copies of this manual

### SPECIFICATIONS

Maximum Fluid Pressure	7500 Psi/517Bar Maximum
Fluid Temperature (with heat guard installed)	175°F
Gun Body	Forged Aluminum
Fluid Path	Stainless Steel
Fluid Inlet Size	3/8" NPS(m) Thread
Gun Weight	660 g / 23.3 oz

### NOTE

The following instructions provide the necessary information for operation and preventative maintenance of the Binks Airless 75M Spray Gun. It is the customer's responsibility to have all operators and service personnel read and understand this manual. Please read and understand all information in this document in order to safely operate your new spray gun.

### ⚠ WARNING

**HAZARD: EYE HAZARD** – Failure to wear safety glasses with side shields could result in serious injury or blindness. All operators and bystanders must always wear safety glasses with side shields that conform to ANSI Standard Z87.1 or European Norm 156.

### ⚠ WARNING

**HAZARD: INJECTION INJURY** – a high pressure stream produced by this equipment can pierce the skin and underlying tissues, leading to a serious injury and possible amputation. See a physician immediately.

**DO NOT TREAT AN INJECTION INJURY AS A SIMPLE CUT!**

Injection can lead to amputation. See a physician immediately.

## BINKS AIRLESS 75M SPRAY GUN

**⚠ WARNING**

**HAZARD: BURN HAZARD –** When using the Airless 75 with a fluid heater, equipment surfaces can become very hot. **ALWAYS** use heat guard 54-7527 when spraying heated materials. **Do not exceed 175°F fluid temperature. Do not exceed manufacturer recommended fluid temperature.**

**⚠ CAUTION**

**KEEP CLEAR OF NOZZLE:** Do not exceed maximum working pressure of **7500 PSI (517 BAR, 51.7 Mpa)**.

**PREVENTION:**

**NEVER** Aim the gun at any part of the body.

**NEVER** Allow any part of the body to touch the fluid stream. **DO NOT** allow body to touch a leak in the fluid hose.

**NEVER** Put hand in front of the gun. Gloves will not provide protection against an injection injury.

**ALWAYS** lock the gun trigger, shut the pump off, and release all pressure before servicing, cleaning the tip or guard, changing the tip, or leaving unattended. Pressure will not be released by turning off the motor. The PRIME/SPRAY valve must be turned to PRIME to relieve the pressure. Refer to the PRESSURE RELIEF PROCEDURE described in the pump manual.

**ALWAYS** Keep the tip guard in place while spraying. The tip guard provides some protection, but is mainly a warning device.

**ALWAYS** Remove the spray tip before flushing or cleaning the system.

**ALWAYS** inspect the hose before each use. The paint hose can develop leaks from wear, kinking, and abuse. A leak can inject material into the skin.

**NEVER** Use a spray gun without a trigger lock and trigger guard in place and in good working order.

All accessories must be rated at 7500 PSI (517 BAR) or higher. This includes spray tips, guns, extensions, and hose.

**NOTE****NOTE TO PHYSICIAN:**

**Injection into the skin is a traumatic injury. It is important to treat the injury as soon as possible. DO NOT DELAY treatment to research toxicity. Toxicity is a concern with some coatings injected directly into the blood stream. Consultation with a plastic surgeon or reconstructive hand surgeon may be advisable.**

**⚠ WARNING**

**HAZARD: EXPLOSION OR FIRE –** Solvent and paint fumes can explode or ignite. **Severe injury and/or property damage can occur.**

**PREVENTION:**

Provide extensive exhaust and fresh air introduction to keep the air within the spray area free from accumulation of flammable vapors.

Avoid all ignition sources such as static electricity sparks, electrical appliances, flames, pilot lights, hot objects, and sparks from connecting and disconnecting power cords or working light switches.

Do not smoke in spray area.

Fire extinguisher must be present and in good working order. Place pump at least 25 feet (7.6 m) away from the spray object in a well ventilated area. Add more hose if necessary. Flammable vapors are often heavier than air. Floor area must be extremely well ventilated. The pump may contain arcing parts that emit sparks and can ignite vapors.

The equipment and objects in and around the spray area must be properly grounded to prevent static sparks.

Use only conductive or grounded high pressure fluid hose. Gun must be grounded through hose connections.

Power cords must be connected to a grounded circuit.

Always flush unit into a separate metal container, at low pump pressure, with spray tip removed.

## BINKS AIRLESS 75M SPRAY GUN

Hold gun firmly against side of container to ground container and prevent static sparks.

Follow the material and solvent manufacturer's warnings and instructions.

Use extreme caution when using materials with a flashpoint below 70° F (21° C). Flashpoint is the temperature that a fluid can produce enough vapor to ignite.

Plastic can cause static sparks. Never hang plastic to enclose a spray area. Do not use plastic drop cloths when spraying flammable materials.

Use lowest possible pressure to flush equipment

### WARNING

**HAZARD: EXPLOSION HAZARD DUE TO INCOMPATIBLE MATERIALS – will cause severe injury or property damage.**

#### PREVENTION:

Do not use materials containing bleach or chlorine.

Do not use halogenated hydrocarbon solvents such as bleach, mildewcide, methylene, chloride and 1,1,1 – trichloroethane. They are not compatible with aluminum.

Contact your coating supplier about the compatibility of material with aluminum.

### WARNING

**HAZARD: HAZARDOUS VAPORS – Paints, solvents, insecticides, and other materials can be harmful if inhaled or come in contact with the body. Vapors can cause severe nausea, fainting, or poisoning.**

#### PREVENTION:

Use a respirator or mask if vapors can be inhaled. Read all instructions supplied with the mask to be sure it will provide the necessary protection.

Wear protective eyewear.

Wear protective clothing as required by coating manufacturer.

### WARNING

**HAZARD: GENERAL – Can cause severe injury or property damage.**

#### PREVENTION:

Read all instructions and safety precautions before operating equipment.

Always disconnect the motor from the power supply before working on the equipment.

Follow all appropriate local, state and national codes governing ventilation, fire prevention, and operation.

The United States Government Safety Standards have been adopted under the Occupational Safety and Health Act (OSHA). These standards, particularly part 1926 of the Construction Standards should be consulted.

Use only manufacturer authorized parts. User assumes all risks and liabilities when using parts that do not meet the minimum specifications and safety devices of the pump manufacturer.

Before each use, check all hoses for cuts, leaks, abrasion, or bulging of cover. Check for damage or movement of couplings. Immediately replace the hose if any of these conditions exist. Never repair a paint hose. Replace it with another grounded high-pressure hose.

All hoses, swivels, guns, and accessories must be pressure rated at or above the maximum operating pressure range of the airless sprayer.

Do not spray outdoors on windy days.

Wear protective clothing to keep paint off skin and hair.

## BINKS AIRLESS 75M SPRAY GUN

### **WARNING**

**The following are general WARNINGS related to the setup, use, grounding, maintenance and repair of this equipment. FIRE AND EXPLOSION HAZARD – Flammable fumes, such as solvents and paint fumes, in work area can ignite or explode. To help prevent fire and explosion:**

Use equipment only in well ventilated area. Provide fresh air ventilation to avoid the buildup of flammable fumes from the material being sprayed or from the solvent.

Eliminate all ignition sources; such as pilot lights, cigarettes, portable electric lamps, and plastic drop cloths (potential static arc).

Keep work area free of debris; including solvent, rags, and gasoline.

Sprayers generate sparks. When flammable liquid is used in or near sprayer or for flushing or cleaning, keep sprayer at least 25 feet (7.6m) away from explosive vapors.

Electrically disconnect all equipment in the spray area. Do not plug or unplug power cords or turn lights on or off when flammable fumes are present.

Ground equipment and conductive objects in work area. Ground object being sprayed.

If there is static sparking or you feel a shock, stop operating immediately. Do not use equipment until you identify and correct the problem.

Keep a fire extinguisher in the work area.

### **SKIN INJECTION HAZARD**

High pressure fluid from spray gun, hose leaks, or ruptured components will pierce skin. This may look like just a cut, but is a serious injury that can cause amputation. Seek immediate surgical treatment. Inform the physician as to what type of material was injected.

Do not point gun at anyone or any part of the body. Do not put your hand or fingers over the spray tip.

Do not stop or deflect leaks with your hand, body, glove or rag. Do not spray without tip guard installed.

Engage trigger lock when not spraying.

Follow pressure relief procedure for your sprayer when you stop spraying and before cleaning, checking or servicing your equipment.

Tighten all fluid connections before operating equipment.

Check all hoses, tubes, and couplings daily. Replace all worn, damaged, or loose parts immediately.

### **EQUIPMENT MISUSE HAZARD**

This equipment is for professional use only.

Read and understand all instructional manuals, tags, and labels before operating equipment.

Use equipment only for its intended purpose. If you are unsure of its purpose, call your local BINKS distributor.

Misuse can cause death or serious injury.

Do not exceed the maximum working pressure or temperature rating of the lowest rated system component. See the technical data in all equipment manuals.

Use fluids and solvents that are compatible with your equipment wetted parts. See technical data in all equipment manuals. Read fluid and solvent manufacturer's warnings. For complete information about your material, request a MSDS from your distributor or retailer.

Check your equipment daily. Do not alter or modify your equipment. Repair or replace worn or damaged parts immediately with genuine BINKS Replacement Parts only.

Do not alter or modify this equipment.

Use equipment only for its intended purpose. Call Binks for more information.

## BINKS AIRLESS 75M SPRAY GUN

Route hoses and cables away from traffic areas, sharp edges, moving parts and hot surfaces.

Do not kink or over bend hoses or use hoses to pull equipment.

Use genuine BINKS hoses. If provided, do not remove the spring guards from hoses, these are on the hoses to prevent rupture from kinking at the connectors.

Keep children and animals away from work area. Comply with all applicable safety regulations.

Do not operate equipment when fatigued or under the influence of drugs or alcohol.

### TOXIC FLUID HAZARD

Know the specific hazards of the fluid you are using. This information is on the MSDS for the material that is being used. Read all fluid manufacturer's warnings.

Store hazardous fluids in approved containers only. Dispose of all hazardous fluids in accordance with all state, local and national guidelines.

Wear the appropriate protective clothing, gloves, eyewear and respirator.

### GROUNDING AND ELECTRIC REQUIREMENTS

The sprayer and gun must be grounded. Grounding reduces the risk of static and electric shock by providing an escape wire for the electrical current due to static build up or in the event of a short circuit. Follow the grounding instructions included in the equipment manual provided with all your spray equipment. Additional grounding instructions for your **BINKS Airless 75M Spray Gun** are provided:

Ground your **BINKS Airless 75M Spray Gun** through connection to a properly grounded fluid hose and pump.

### SET UP INSTALLATION

#### WARNING

Never attempt to assemble, change, or clean the gun, tip, or tip guard without first relieving pressure from the spray system. Follow the "PRESSURE RELIEF PROCEDURE" in the sprayer's equipment manual.

#### WARNING

Always use tip safety guard for added protection against injection. Beware that the guard alone will not prevent injection. NEVER cut off tip guard! Always engage gun trigger lock when the gun is not in use. Before servicing equipment, consult all equipment manuals and follow all warnings.

#### WARNING

Do not allow fluid to exceed the fluid manufactures recommended maximum temperature. Gun must include heat guard (54-7527) to be used with heated materials.

#### NOTE

**BINKS Airless Spray Gun Safety Tip Guards for the 7500 PSI (517 BAR) gun are gray in color.**

## BINKS AIRLESS 75M SPRAY GUN

### BINKS Airless 75M PROFESSIONAL AIRLESS SPRAY GUN 7500 PSI (517 BAR) MODEL 0811-7500-4

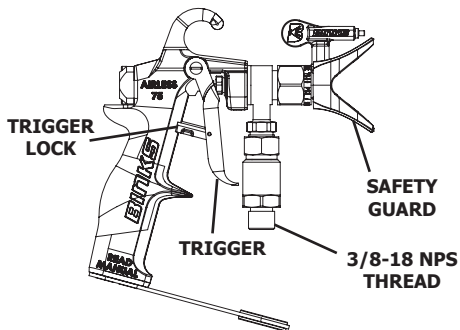

If you are using a genuine BINKS tip, follow the instructions below to install the guard and tip. If you are using a different tip, follow the installation instructions provided with the tip that you are using.

#### INSTALLATION OF THE TIP AND GUARD

1. Make sure that the tip and tip guard are rated for use at 7500 PSI. (Genuine BINKS parts will be gray in color.)
2. Use seal alignment tool on BINKS tip handle to insert seal and pressure gasket into back of guard, turn to align with tip shaft opening.
3. Insert tip into opening on BINKS guard.

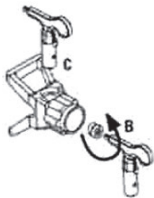

#### NOTE

**Narrow end of tip handle should be in forward position for spraying.**

4. Thread the guard onto gun head until it stops. Tighten slightly with wrench – DO NOT OVER TIGHTEN.

#### CONNECTION TO THE HOSE

Attach a properly grounded fluid hose to the fluid hose connection fitting (3/8 – 18 NPS thread) on the bottom of the handle of your spray gun. Use two (2) wrenches – one on the gun and one on the hose. Tighten securely.

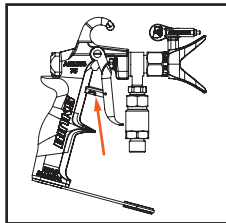

LOCKED

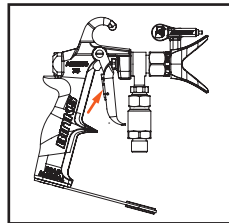

UNLOCKED

#### GUN OPERATION

1. Make sure your tip is in the spray position.
2. Start your sprayer following the instructions provided in the equipment owner's manual.
3. Pull trigger to achieve flow through gun.
4. Adjust the fluid pressure on the sprayer until proper atomization is achieved. Always spray at the lowest pressure necessary to get the desired atomization.

#### TIP CLOGS

If you are using a Genuine BINKS spray tip, follow the instructions below to clear a clogged tip. If you are using a different tip, follow the instructions included in the equipment manual provided with that tip.

1. Engage Trigger Lock. Rotate tip handle 180° to the reverse position.
2. Unlock trigger. Point the gun into a bucket holding the gun nose away from you. Trigger the gun briefly to expel the clog.
3. Engage Trigger Lock. Rotate tip handle 180° to the spray position.
4. Unlock trigger. Spray a test to be sure the clog is completely expelled.



## BINKS AIRLESS 75M SPRAY GUN

### NOTE

**If clog is not completely expelled after following the above steps, repeat steps 1-4 until the clog is completely cleared.**

## CLEANING AND MAINTENANCE

### CLEAN DAILY

Maintaining a clean gun is important to ensure trouble-free operation and extend the service life of your gun. Always flush the gun thoroughly after each use and store in a warm, dry location. DO NOT leave the gun or any of its parts in water or solvents.

Always flush gun outside if possible and at least 25 ft (7.5 m) away from sprayer.

Area must be free of flammable vapors.

Always flush at minimum pressure. Always remove tip and guard.

Static electricity buildup may result in fire or explosion in the presence of flammable vapors.

Always hold the gun firmly against a grounded, metal container when flushing.

### TROUBLESHOOTING

Spray gun distance from work surface should be at a point where maximum fan pattern is evident. This distance is normally 8 to 14 inches.

Excessive fluid pressure will distort the spray pattern. Spray at the lowest acceptable pressure.

Hour-glass and tails on spray patterns normally indicate too low a fluid pressure for the nozzle tip orifice size or the material is too viscous or thick. Increase the pressure or thin the material.

Distorted patterns may be the result of worn or plugged tips. Clean (see tip clogs) or replace the spray tip.

Airless spray guns are either on or off. You cannot feather with airless guns as you can with air atomized equipment.

Successive strokes may require overlapping. Typical overlap is 30%.

### TO REPLACE NEEDLE ASSEMBLY (11)

1. Shut off power supply to pump and release pressure from gun. Remove gun from hose.
2. Remove screws and rear cap. (12)
3. Remove trigger and trigger stud (9)
4. Unscrew gland nut of item 10.
5. Pull needle assembly out from back of gun.
6. Reinsert needle assembly (of step 5) into position through back of gun body assembly. Tighten gland nut.
7. Reassemble items.

### TO REPLACE PACKING

1. Remove needle assembly following steps 1-5 under 'To Replace Needle Assembly'.
2. Locate slot in packing gland (14), pry apart and push off.
3. Replace with new packing gland, and reassemble.

### TO ADJUST PACKING GLAND

1. Shut off power supply to pump and release pressure from gun. Remove gun from hose.
2. Use 7/16" open-end wrench to turn gland nut clockwise to eliminate any leakage at gland.
3. If sluggish trigger operation is noted, turn gland nut counterclockwise in 1/16 turn increments until drag is eliminated.
4. If leakage cannot be stopped without excessive drag on trigger, replace packing.

**BINKS AIRLESS 75M SPRAY GUN**

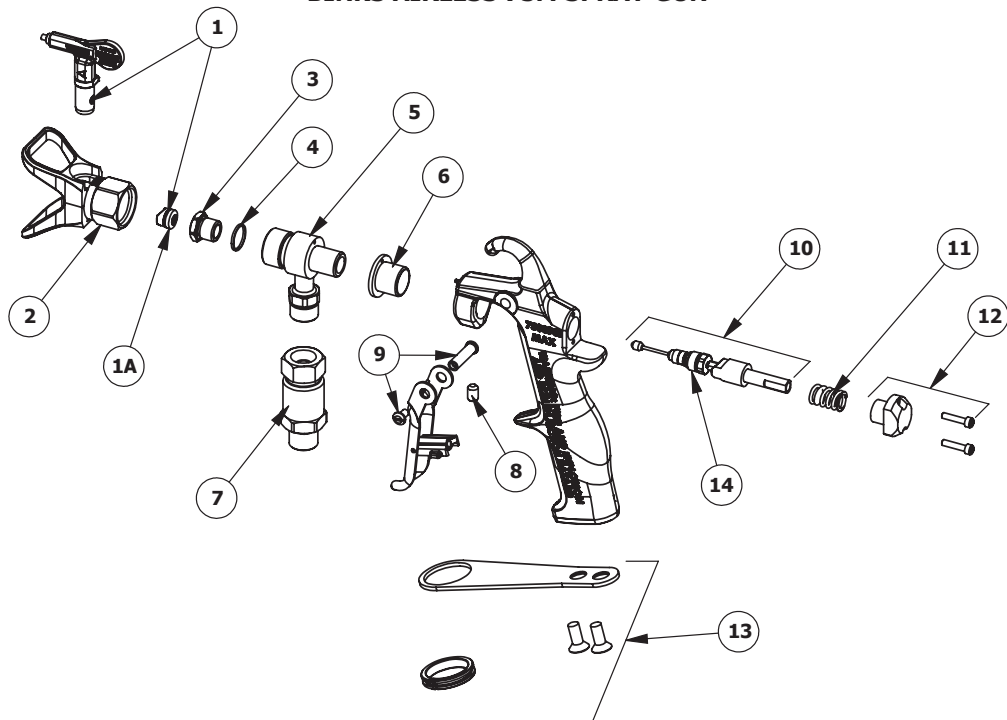

**BINKS AIRLESS 75M SPRAY GUN PARTS LIST**

ITEM NO.	PART NUMBER	DESCRIPTION	QTY.
1	—	TWIST TIP 7500, PSI, SEE CHART	1
1A	54-7539-K2	AIRLESS 75 TWIST TIP BRACE KIT	1
2	1108-75B	7500 PSI TWIST TIP GUARD	1
3	54-7537-K	DIFFUSER NUT KIT	1
4	54-2096-K5	WASHER (KIT-5)	1
5	54-7544	75M GUN FLUID INLET MACHINING	1
6	54-7502-K3	BODY INSULATOR	1
7	54-2351	3/8 (F) NPS X 3/8 (M) NPS SWIVEL	1
8	20-5865-K3	SET SCREW (KIT OF 3)	1
9	54-7534-K	TRIGGER KIT	1
10	54-7512	NEEDLE ASSEMBLY	1
11	54-7508	SPRING	1
12	54-7530-K	REAR CAP KIT	1
13	54-5342-K	HOSE BRACKET KIT	1
14	54-2949	PACKING GLAND	1

## BINKS SPRAY TIP SELECTION CHART

PART NUMBER 9-XXX-75 (Tips rated for use at 7500 psi)

All of the following tips will have a grey tip handle

	4" spray pattern	6" spray pattern	8" spray pattern	10" spray pattern	12" spray pattern	14" spray pattern
<b>.007" orifice</b>		307				
<b>.009" orifice</b>		309	409	509		
<b>.011" orifice</b>	211	311	411	511	611	
<b>.013" orifice</b>	213	313	413	513	613	713
<b>.015" orifice</b>	215	315	415	515	615	715
<b>.017" orifice</b>	217	317	417	517	617	717
<b>.019" orifice</b>			419	519	619	
<b>.021" orifice</b>			421	521	621	
<b>.023" orifice</b>				523	623	
<b>.025" orifice</b>				525	625	
<b>.027" orifice</b>					627	
<b>.031" orifice</b>					631	
<b>.035" orifice</b>			435		635	

## BINKS ACCESSORIES

ORDER NUMBER	DESCRIPTION
72-2332	Swivel Adapter 1/4" M x 1/4" F
72-2333	Swivel Adapter 3/8" M x 1/4" F
72-2340	Swivel Adapter with inlet filter (60 Mesh)
72-2341	Swivel Adapter with inlet filter (100 Mesh)
54-1836	60 Mesh filter
54-1835	100 Mesh filter
52-5208	36" Airless Tip Extension
52-5209	60" Airless Tip Extension
72-2339	High Pressure "Y" Block (7,250 psi max)

## BINKS AIR HOSE

ORDER NUMBER	DESCRIPTION
71-4870	Hose Whip 1/4" F x 3/8" M 3 ft, 10,000 psi working pressure
71-4840	Hose 1/4" x 25 ft 10,000 psi working pressure
71-4841	Hose 1/4" x 50 ft 10,000 psi working pressure
71-4860	Hose 3/8" x 25 ft 8,000 psi working pressure
71-4861	Hose 3/8" x 50 ft 8,000 psi working pressure

## WARRANTY POLICY

Binks products are covered by Finishing Brands one year materials and workmanship limited warranty. The use of any parts or accessories, from a source other than Finishing Brands, will void all warranties. For specific warranty information please contact the closest Finishing Brands location listed below.

Finishing Brands reserves the right to modify equipment specifications without prior notice. DeVilbiss, Ransburg, BGK, and Binks are registered trademarks of Finishing Brands. ©2014 Finishing Brands. All rights reserved.



Binks is part of Finishing Brands, a global leader in innovative spray finishing technologies. For technical assistance or to locate an authorized distributor, contact one of our international sales and customer support locations below.

### USA/Canada

www.binks.com  
info@finishingbrands.com  
Tel: 1-800-992-4657  
Fax: 1-888-246-5732

### Mexico

www.finishingbrands.com.mx  
sales@finishingbrands.com.mx  
Tel: 011 52 55 5321 2300  
Fax: 011 52 55 5310 4790

### Brazil

www.devilbiss.com.br  
sales@devilbiss.com.br  
Tel: +55 11 5641 2776  
Fax: 55 11 5641 1256

### United Kingdom

www.finishingbrands.eu  
info@finishingbrands.eu  
Tel: +44 (0)1202 571 111  
Fax: +44 (0)1202 573 488

### France

www.finishingbrands.eu  
info@finishingbrands.eu  
Tel: +33(0)475 75 27 00  
Fax: +33(0)475 75 27 59

### Germany

www.finishingbrands.eu  
info@finishingbrands.eu  
Tel: +49 (0) 6074 403 1  
Fax: +49 (0) 6074 403 281

### China

www.finishingbrands.com.cn  
mkt@finishingbrands.com.cn  
Tel: +8621-3373 0108  
Fax: +8621-3373 0308

### Japan

www.ransburg.co.jp  
binks-devilbiss@ransburg.co.jp  
Tel: 081 45 785 6421  
Fax: 081 45 785 6517

### Australia

www.finishingbrands.com.au  
sales@finishingbrands.com.au  
Tel: +61 (0) 2 8525 7555  
Fax: +61 (0) 2 8525 7500

DeVILBISS

Ransburg

BGK

BINKS

