

MODEL

SP 18VA

HITACHI
POWER TOOLS

**ELECTRONIC SANDER POLISHER
SP 18VA**

**TECHNICAL DATA
AND
SERVICE MANUAL**

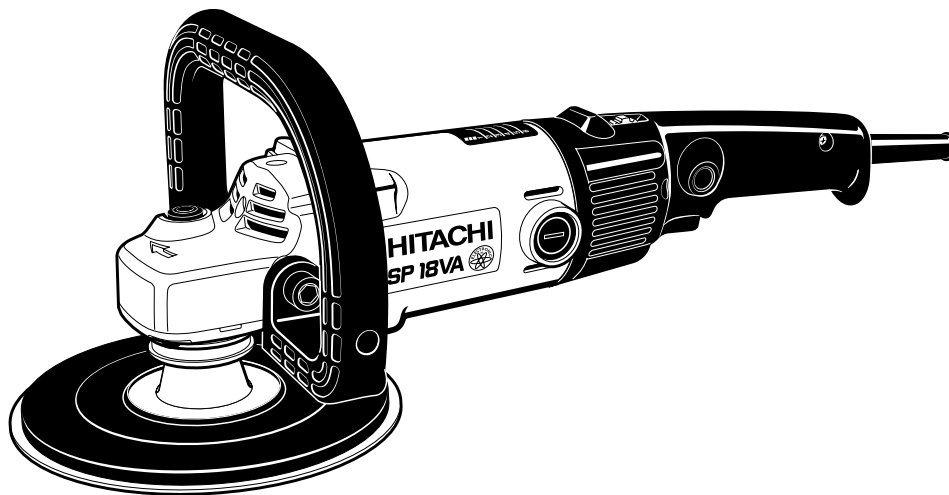

S

LIST No. 0352

Jun. 2002

SPECIFICATIONS AND PARTS ARE SUBJECT TO CHANGE FOR IMPROVEMENT

REMARK:

Throughout this TECHNICAL DATA AND SERVICE MANUAL, a symbol(s) is(are) used in the place of company name(s) and model name(s) of our competitor(s). The symbol(s) utilized here is(are) as follows:

Symbol Utilized	Competitor	
	Company Name	Model Name
C	MAKITA	9227C/9227CB



CONTENTS

	Page
1. PRODUCT NAME	1
2. MARKETING OBJECTIVE	1
3. APPLICATIONS	1
4. SELLING POINTS	1
4-1. Selling Point Descriptions	2
5. SPECIFICATIONS	3
6. COMPARISONS WITH SIMILAR PRODUCTS	4
6-1. Specification Comparisons	4
6-2. Practical Test Data	5
7. PRECAUTIONS IN SALES PROMOTION	6
7-1. Handling Instructions	6
7-2. Caution on Name Plate	6
7-3. Precautions on Usage	6
8. FUNCTION AND OPERATION OF THE CONTROL CIRCUIT	7
8-1. Control Circuit (Block Diagram)	7
8-2. Function of Each Block	7
8-3. Motor Characteristics and Voltage Applied to the Motor	8
9. PRECAUTIONS IN DISASSEMBLY AND REASSEMBLY	9
9-1. Disassembly of the Armature Ass'y	9
9-2. Disassembly of the Stator Ass'y	10
9-3. Disassembly of the Gear	10
9-4. Reassembly	11
9-5. Tightening Torque	11
9-6. Wiring Diagram	11
9-7. Insulation Tests	12
9-8. Gear Backlash Value	12
9-9. No-Load Current Value	12
10. STANDARD REPAIR TIME (UNIT) SCHEDULES	13
Assembly Diagram for SP 18VA	

1. PRODUCT NAME

Hitachi Electronic Sander Polisher, Model SP 18VA [180 mm (7")]

2. MARKETING OBJECTIVE

The Model SP 18VA has been developed to upgrade and replace the current Model SP 18V. The main improvements are increased motor power, weight reduction and improved operability.

3. APPLICATIONS

- Sanding metallic surfaces.
- Preparatory sanding and removing rust from metallic surfaces prior to painting, and removing paint prior to repainting.
- Finishing woodwork and making flush joints of wooden plates.
- Preparatory sanding wooden surfaces prior to painting.
- Finishing and polishing painted metallic surfaces of motor vehicles, rolling stocks, elevators, refrigerators, sewing machines, washing machines, medical instruments, and so on.
- Polishing lacquered surfaces on wooden products such as furniture.
- Polishing synthetic resin and ebonite products.

4. SELLING POINTS

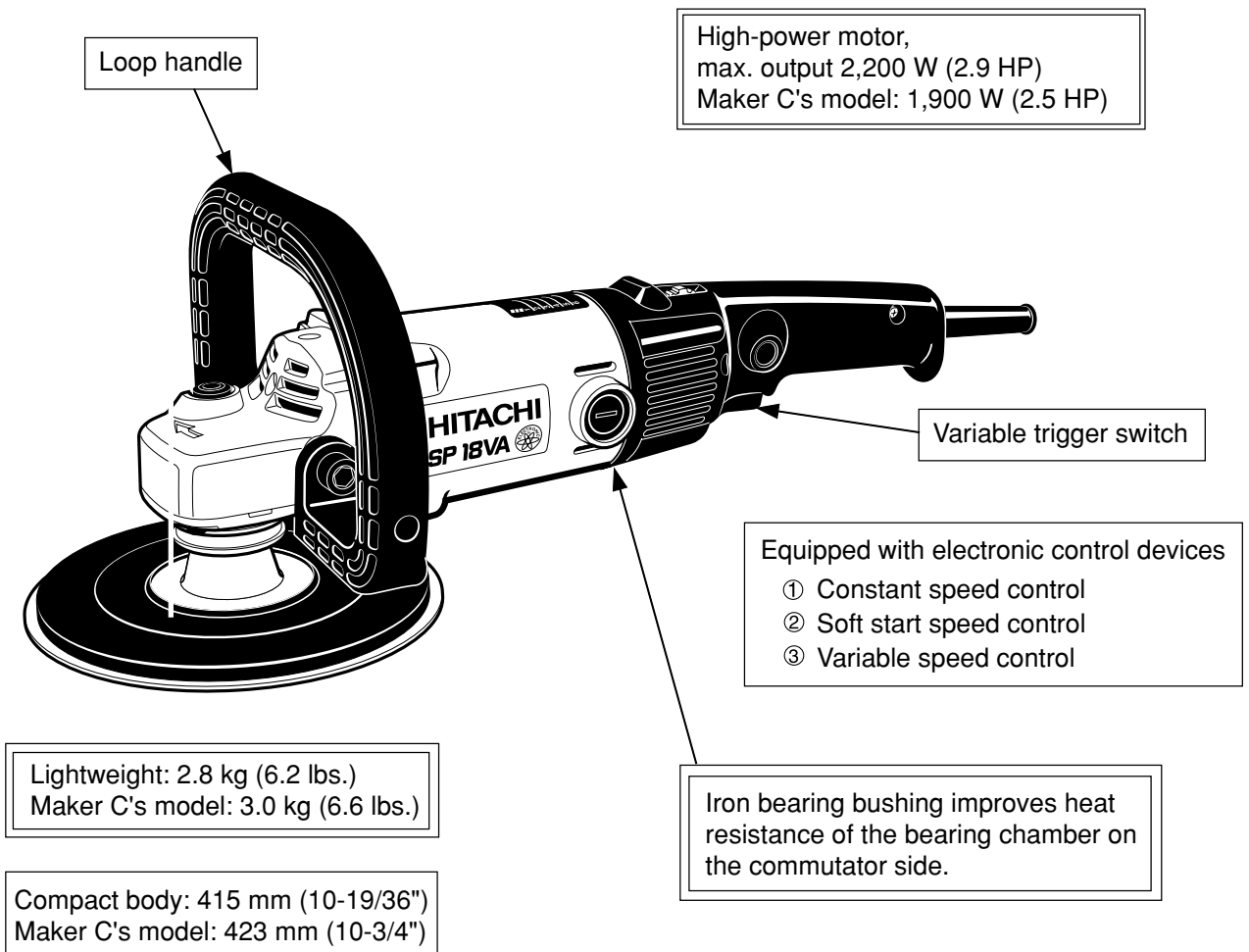

4-1. Selling Point Descriptions

1) High-power motor and light weight

The Model SP 18VA is equipped with high-power motor and is more powerful than the current Model SP 18V although it is compact and lightweight. We could say that the ratio of the motor's maximum output to the product's weight defines its performance. Compared with a typical competitor's model in terms of this indicator, the Model SP 18VA proves to have the highest performance.

Table 1 Comparison of max. output and product weight

Item	Maker Model	Hitachi		C
		SP 18VA	SP 18V	
Max output *1	(W)	2,560 (3.4 HP)	1,700 (2.3 HP)	1,900 (2.5 HP)
Actual product weight *2	(kg)	2.8 (6.2 lbs.)	3.0 (6.6 lbs.)	3.0 (6.6 lbs.)
Max output/product weight	(W/kg)	914 (0.55 HP/lbs.)	567 (0.35 HP/lbs.)	633 (0.38 HP/lbs.)

*1 Max. output may vary depending on the market.

*2 Actual product weight is a measured weight and excludes cord, loop handle, rubber pad and washer nut.

2) Iron bearing bushing

An iron bearing bushing is newly added to the housing. The heat resistance of the bearing chamber on the commutator side is significantly improved in comparison with current models.

Current ball bearing chamber of housing (SP 18V)

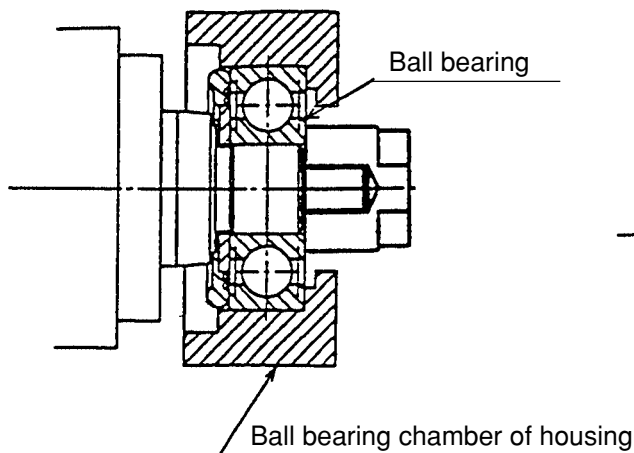

New ball bearing chamber of housing (SP 18VA)

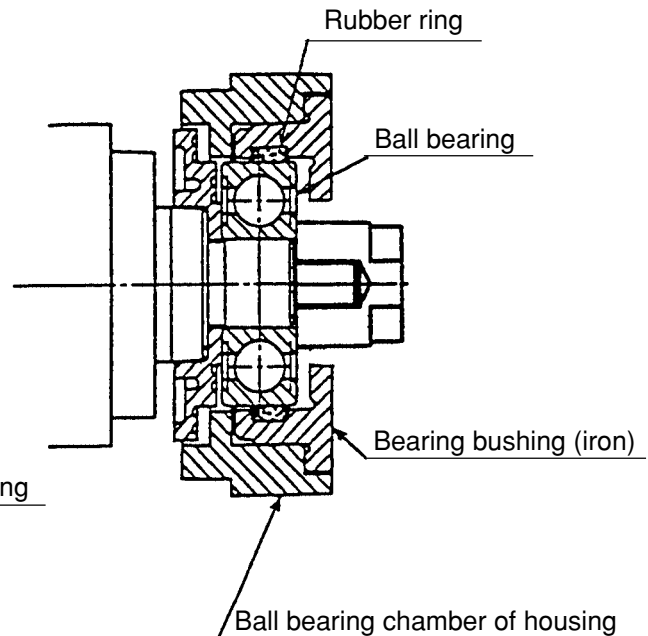

Fig. 2

5. SPECIFICATIONS

Model	SP 18VA		
Capacity disc dia.	180 mm (7")		
Power source	AC single phase 50 or 60 Hz		
Voltage, current and input	Voltage (V)	Current (A)	Input (W)
	110	12.0	1,250
	120	11.0	
	220	6.0	
	230	5.7	
	240	5.5	
Rotation speed (no-load)	0 to 600/3,400 /min		
Type of motor	AC single-phase commutator motor		
Type of switch	Trigger switch		
Enclosure	Material: Housing Glassfiber reinforced polyamide resin (green) Handle Glassfiber reinforced polyamide resin (black) Gear cover } Aluminum alloy die casting Packing gland } Coating: Gear cover } Metallic silver Packing gland }		
Weight	Net*	2.8 kg (6.2 lbs.)	
	Gross	5.5 kg (12.2 lbs.)	
Packaging	Corrugated cardboard box		
Standard accessories	Rubber pad 1 Loop handle 1 Wrench 1		

* Weight excludes cord, loop handle, rubber pad and washer nut.

- Relationship between dial settings and rotation speeds of the Model SP 18VA

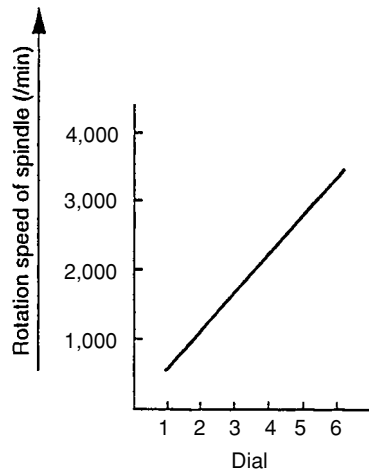

6. COMPARISONS WITH SIMILAR PRODUCTS

6-1. Specification Comparisons

Maker		HITACHI			C
Model		SP 18VA	SP 18V		
Capacity disc dia.	mm	180 (7")	180 (7")	180 (7")	
Input	W	1,250	1,100	1,200	
Output* ¹	W	680	407	555	
Max. output* ¹	W	2,560	1,700	1,900	
Rotation speed (no-load)	/min.	0 – 600/3,400	1,400 – 3,400	0 – 600/3,000	
Variable speed control		Dial and trigger switch	Dial	Dial and trigger switch	
Overload protection control		None	Equipped	None	
No-load sound pressure level	dB/A	84	86	83	
Spindle lock		Equipped	Equipped	Equipped	
Handle type		Loop handle	Side handle	Loop handle	
Weight* ²	Catalog	kg	2.8 (6.2 lbs.)	3.0 (6.6 lbs.)	3.0 (6.6 lbs.)
	Actual	kg	2.8 (6.2 lbs.)	3.0 (6.6 lbs.)	3.0 (6.6 lbs.)
Dimensions	H	mm	126 (3-7/36")	128 (3-1/4")	134 (3-5/12")
	h	mm	81 (2-1/18")	82 (2-1/12")	88 (2-2/9")
	L	mm	415 (10-19/36")	417 (10-7/12")	423 (10-3/4")

*¹ Output may vary depending on the market.

*² Weight excludes cord, loop handle, rubber pad and washer nut.

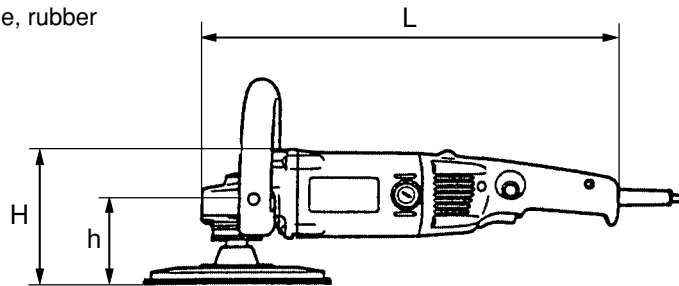

6-2. Practical Test Data

1) Comparisons in torque vs. rotation speed

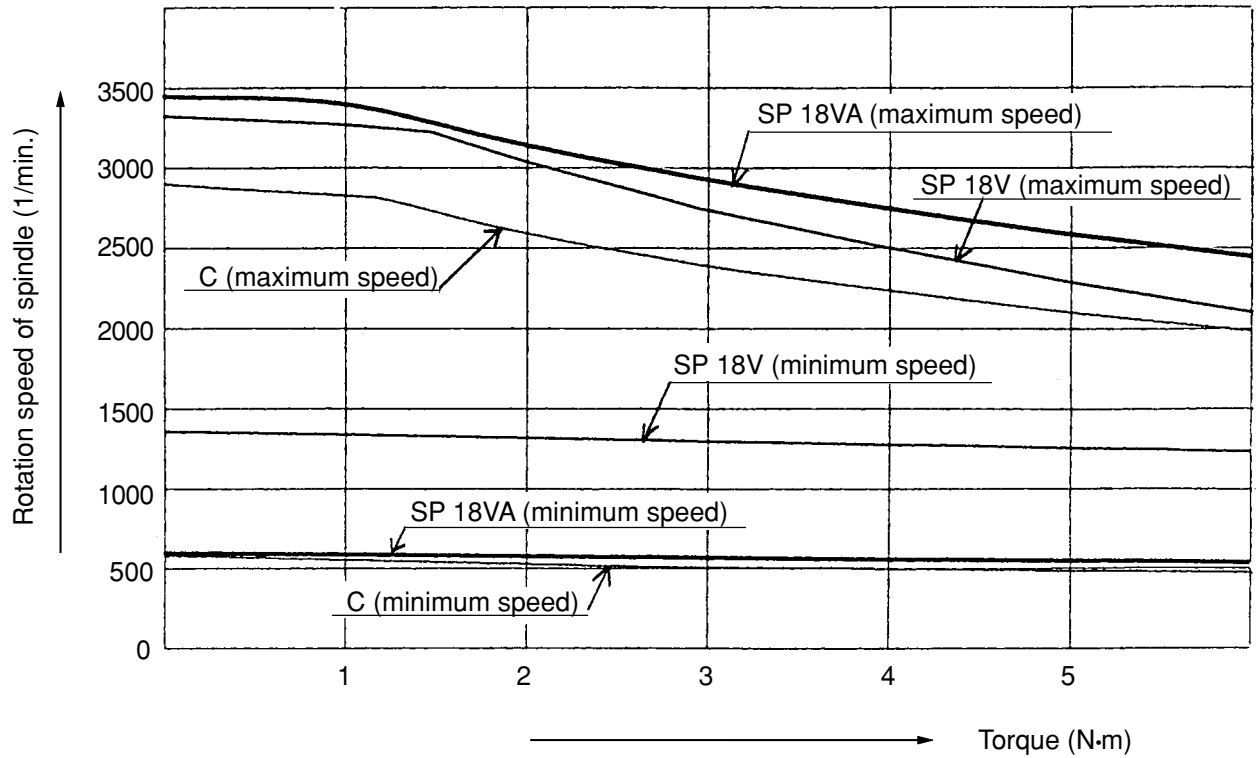

2) Sanding performance comparisons

Workpiece material: SPCC (mild steel)
 Sanding disc used: AP #50
 Applied pressure: 4 kg
 Speed: Maximum speed

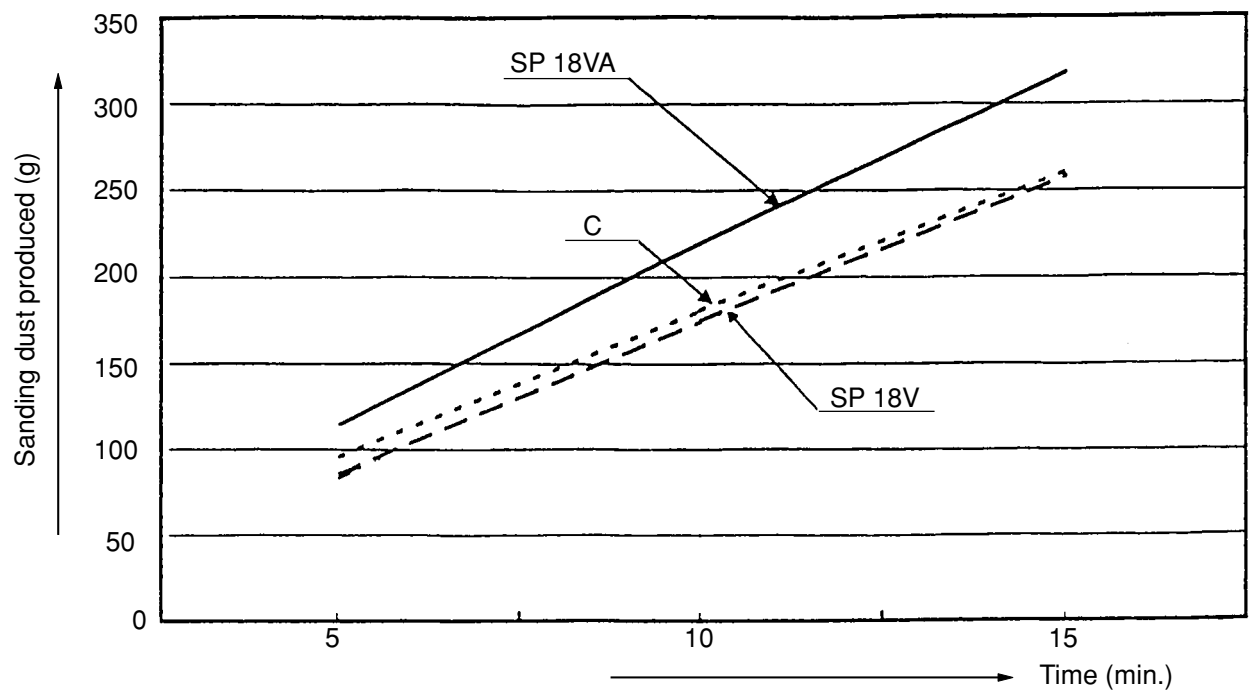

7. PRECAUTIONS IN SALES PROMOTION

In the interest of promoting the safest and most efficient use of the Model SP 18V Electronic Sander Polisher by all of our customers, it is very important that at the time of sale the salesperson carefully ensures that the buyer seriously recognizes the importance of the contents of the Handling Instructions, and fully understands the meaning of the precautions listed on the Caution Plate attached to each tool.

7-1. Handling Instructions

Although every effort is made in each step of design, manufacture and inspection to provide protection against safety hazards, the dangers inherent in the use of any electric tool cannot be completely eliminated. Accordingly, general precautions and suggestions for the use of electric power tools, and specific precautions and suggestions for the use of the Electronic Sander Polisher are listed in the Handling Instructions to enhance the safe and efficient use of the tool by the customer. Salespersons must be thoroughly familiar with the contents of the Handling Instructions to be able to offer appropriate guidance to the customer during sales promotion.

7-2. Caution on Name Plate

Each tool is provided with a Name Plate which contains the following basic safety precautions in the use of the tool.

(1) For Australia, New Zealand and China

CAUTION

Read thoroughly HANDLING INSTRUCTIONS before use.

(2) For U.S.A. and Canada

-WARNING- • To reduce the risk of injury, user must read and understand instruction manual.
AVERTISSEMENT • Afin de réduire le risque de blessures, l'utilisateur doit lire et bien comprendre le mode d'emploi.

(3) For Switzerland, U.K., Germany, Belgium, France, Netherlands, Austria, Spain, Italy, Finland, Denmark and Norway



7-3. Precautions on Usage

Never press the pushing button while the spindle is rotating:

If the pushing button is pressed while the spindle is rotating, the spindle will stop immediately. In such a case, there is a danger that the washer nut may be loosened so that the rubber pad and wool bonnet fly off unexpectedly to cause possible serious injury.

8. FUNCTION AND OPERATION OF THE CONTROL CIRCUIT

8-1. Control Circuit (Block Diagram)

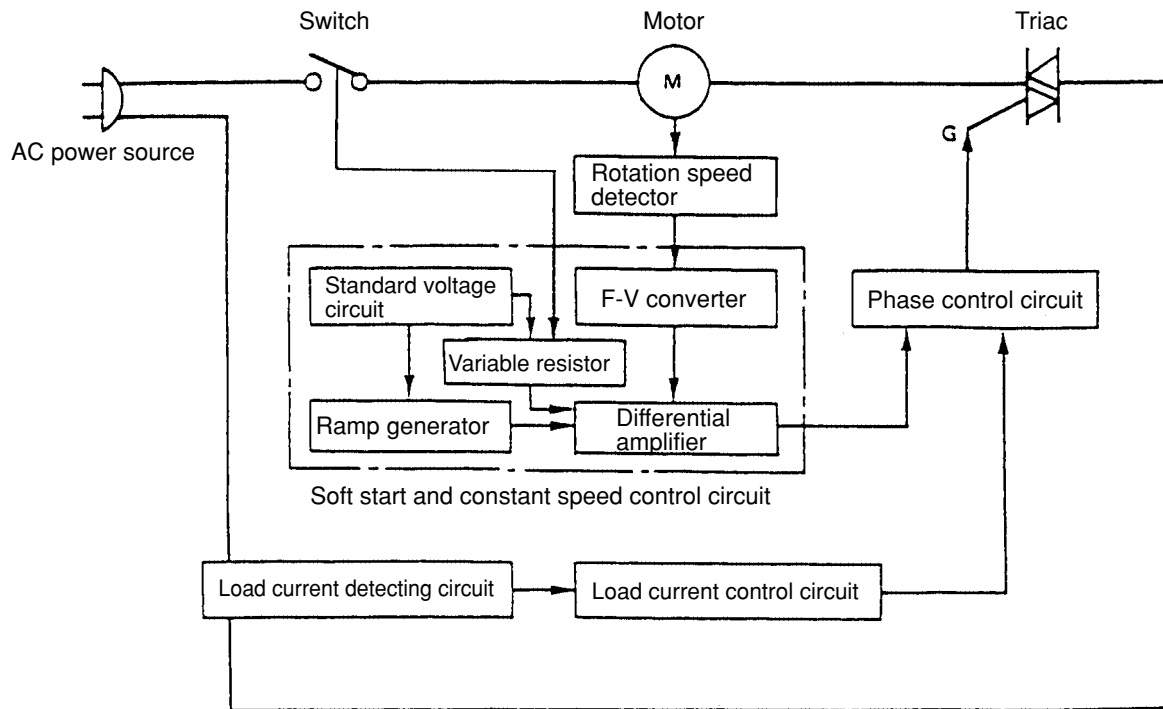

8-2. Function of Each Block

(1) Rotation speed detector:

Generates a frequency signal proportionate to the actual rotation speed of the motor. A magnetic sensor in the controller monitors changes in the magnetic flux from a magnet, and generates a frequency signal.

(2) F-V converter:

Converts the frequency signal produced by the rotation speed detector into DC voltage.

(3) Standard voltage circuit:

Generates a standard voltage which determines the no-load rotation speed of the motor and serves as a reference in maintaining constant rotation speed even when there are fluctuations in the load.

(4) Ramp generator:

Generates the voltage which determines the acceleration of the motor. The soft start function when the motor is turned on is achieved through a gradual increase of the voltage generated by this circuit. When fully charged, the voltage of the ramp generator becomes equal to the standard voltage (above).

(5) Differential amplifier:

Compares the voltage from the ramp generator voltages received from the F-V converter (which is proportionate to the actual motor rotation speed), and amplifies the result.

This circuit functions as follows to maintain a constant rotation speed:

Motor rotation speed decreases (or increases) → frequency signal decreases (or increases) → output voltage of the F-V converter decreases (or increases) → output voltage of the differential amplifier increases (or decreases).

(6) Load current detecting circuit:

Detects the load current by means of a low resistance resistor which is in series with the motor and the triac.

(7) Load current control circuit:

When the detected load is excessive (overload), this circuit sends a command (control signal) to reduce power to the motor.

(8) Phase control circuit:

Generates the trigger signals necessary to turn the triac on, and delivers them to the gate of the triac. The conductive angle of the triac is determined by the timing of the generated trigger signals.

When starting the tool: Controlled by the soft start circuit, the phase control circuit generates trigger signals to gradually increase the conductive angle of the triac.

Constant speed operation: When there are variations in the rotation speed, the phase control circuit generates trigger signals to keep the rotation speed as close as possible to the present rotation speed determined by the standard voltage circuit. In short, when the load increases and causes the rotation speed to decrease, the conductive angle of the triac is increased, and the voltage applied to the motor is increased. In this way, the rotation speed is kept as close as possible to the standard rotation speed.

8-3. Motor Characteristics and Voltage Applied to the Motor

Phase control voltage waveform

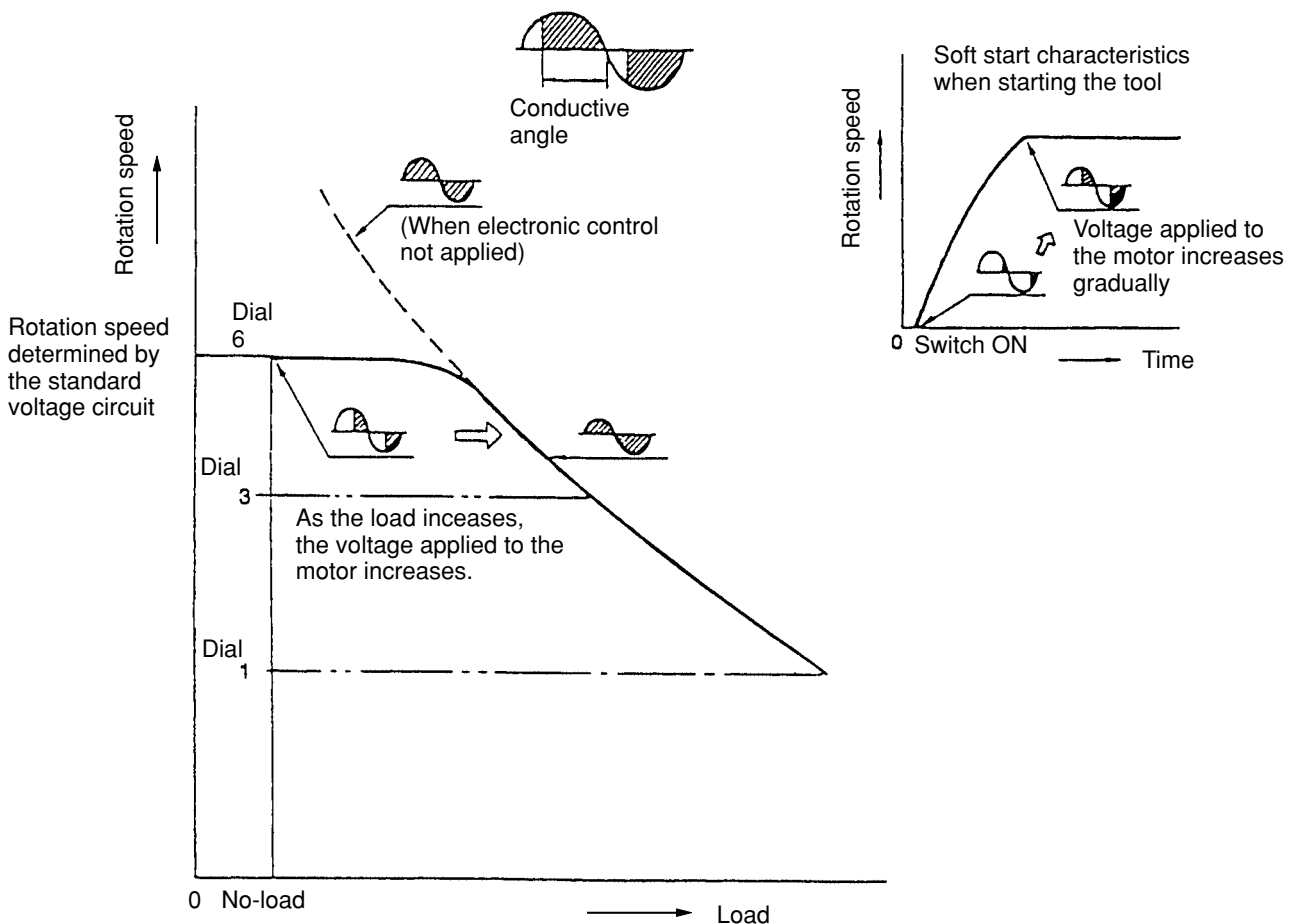

9. PRECAUTIONS IN DISASSEMBLY AND REASSEMBLY

The **[Bold]** numbers in the descriptions below correspond to the item numbers in the Parts List and exploded assembly diagram for the Model SP 18VA.

9-1. Disassembly of the Armature Ass'y

- (1) Loosen the two Brush Caps **[45]**, and take out the Carbon Brushes **[46]**.
- (2) Remove the four Tapping Screws (W/Flange) D5 x 30 **[2]**. The Armature Ass'y **[13]** can then be taken out simultaneously with the Gear Cover Ass'y **[5]**, Packing Gland **[30]** and related parts.
- (3) Remove the four Seal Lock Screws (W/Sp. Washer) M5 x 14 (Black) **[31]**, and remove the Packing Gland **[30]**, and related parts.
- (4) After removing the three Seal Lock Screws (W/Sp. Washer) M4 x 10 **[1]**, the Armature Ass'y **[13]** can be extracted together with the Bearing Cover (B) **[12]**, and related parts.
- (5) Carefully wrap the Armature Ass'y **[13]** with a soft, clean rag to protect it from being damaged, and clamp it securely in a vise. Remove the Retaining Ring for D8 Shaft.
- (6) As illustrated in Fig. 3, the Ball Bearing 6200DDCMPS2L **[9]** can be removed from the Armature Ass'y **[13]** by utilizing a J-204 Bearing Puller (special repair tool, Code No. 970982).
After the Ball Bearing has been removed, Bearing Cover (B) **[12]** can be easily taken off.

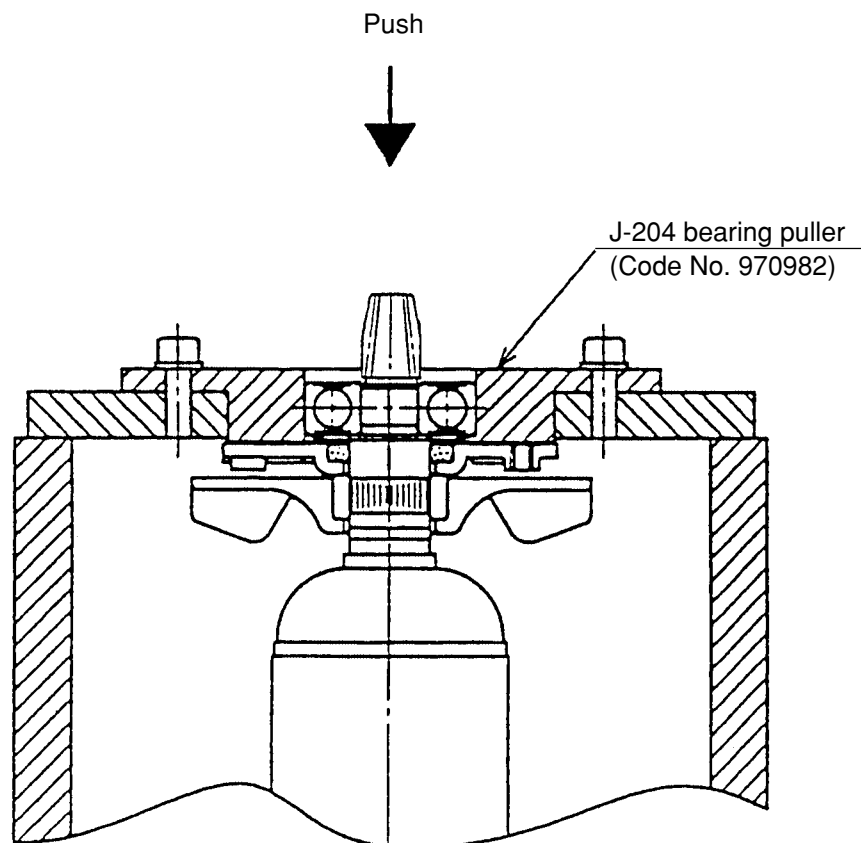

Fig. 3

9-2. Disassembly of the Stator Ass'y

- (1) After taking out the Armature Ass'y [13], loosen the four Tapping Screws (W/Flange) D5 x 20 (Black) [51], and the two Tapping Screws (W/Flange) D4 x 20 (Black) [52] and remove Handle (A) [50] and Handle (B) [49].
- (2) Disconnect the lead wires of the Stator Ass'y [16] from the Controller Switch [42].
- (3) Disconnect the Brush Terminal [17] from the Brush Holders [47] and take out the Bearing Bushing [41].
- (4) Finally, loosen the two Hex. Hd. Tapping Screws D5 x 60 [15], and the Stator Ass'y [16] can be taken out of the Housing Ass'y [35]. If the Stator Ass'y [16] cannot be easily taken out of the Housing Ass'y [35], disassembly can be facilitated by heating the Housing Ass'y to a temperature of approximately 60°C (140°F) with an appropriate heating device.

9-3. Disassembly of the Gear

- (1) Loosen the four Seal Lock Screws (W/Sp. Washer) M5 x 14 (Black) [31], and remove the Packing Gland [30] together with the Spindle [27] and the Gear [22] from the Gear Cover Ass'y [5] as a unit.
- (2) When it is necessary to remove the Gear [22] from the Spindle [27], it is highly recommended that the special repair tools described below be utilized.

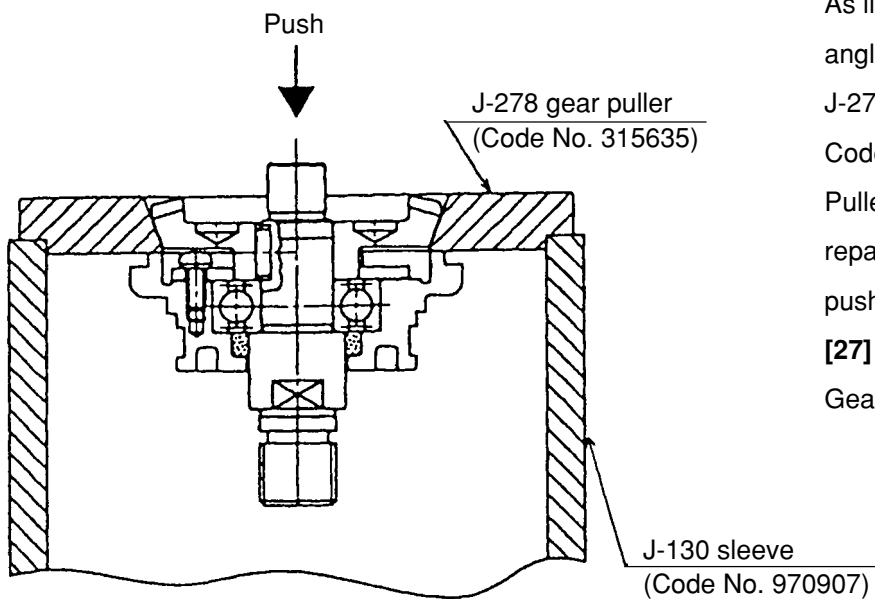

Fig. 4

As illustrated in Fig. 4, support the angled surface of the Gear [22] with a J-278 Gear Puller (special repair tool, Code No. 315635), rest the J-278 Gear Puller on the J-130 Sleeve (special repair tool, Code No. 970907), and push down on the tip of the Spindle [27] with a hand press to remove the Gear [22].

9-4. Reassembly

Perform reassembly in the reverse order of disassembly while observing the given precautions and taking care of the following points.

- (1) After disassembly, thoroughly remove old grease from the inside of the Gear Cover Ass'y [5], and insert 25 g of new grease (Nippeco JF-375, Code No. 930036, is recommended.) prior to reassembly. When inserting grease, apply it to the pinion gear teeth surfaces, and to the needle bearing inside the gear cover.
- (2) When replacing the ball bearing on the commutator side of the Armature Ass'y [13], be very careful to ensure that the Dust Seal [34] is assembled in the proper direction. The Dust Seal [34] plays an important role in dustproofing of the ball bearing, and must be replaced with a new one if disassembled.
- (3) Apply Three Bond TB 1406 Screw Locking Agent to the following screws.
 - Three Seal Lock Screws (W/Sp. Washer) M4 x 10 [1] which fix Bearing Cover (B) [12] in place.
 - Three Seal Lock Screws (W/Sp. Washer) M4 x 10 [23] which fix Bearing Cover (A) [24] in place.
 - Four Seal Lock Screws (W/Sp. Washer) M5 x 14 (Black) [31] which fix Packing Gland [30] in place.

9-5. Tightening Torque

D4 Tapping Screws (W/Flange) [53], [52], [43]	2.0 ± 0.5 N·m (20 ± 5 kgf·cm, 1.5 ± 0.4 ft-lbs.)
D5 Tapping Screws (W/Flange) [51] [2]	}	2.9 ± 0.5 N·m (30 ± 5 kgf·cm, 2.2 ± 0.4 ft-lbs.)
D5 Hex. Hd. Tapping Screw [15]		
M4 Seal Lock Screw (W/Sp. Washer) [23], [1]	1.8 ± 0.4 N·m (18 ± 4 kgf·cm, 1.3 ± 0.3 ft-lbs.)
M5 Seal Lock Screw (W/Sp. Washer) [31]	3.4 ± 0.7 N·m (35 ± 7 kgf·cm, 2.5 ± 0.5 ft-lbs.)

9-6. Wiring Diagram

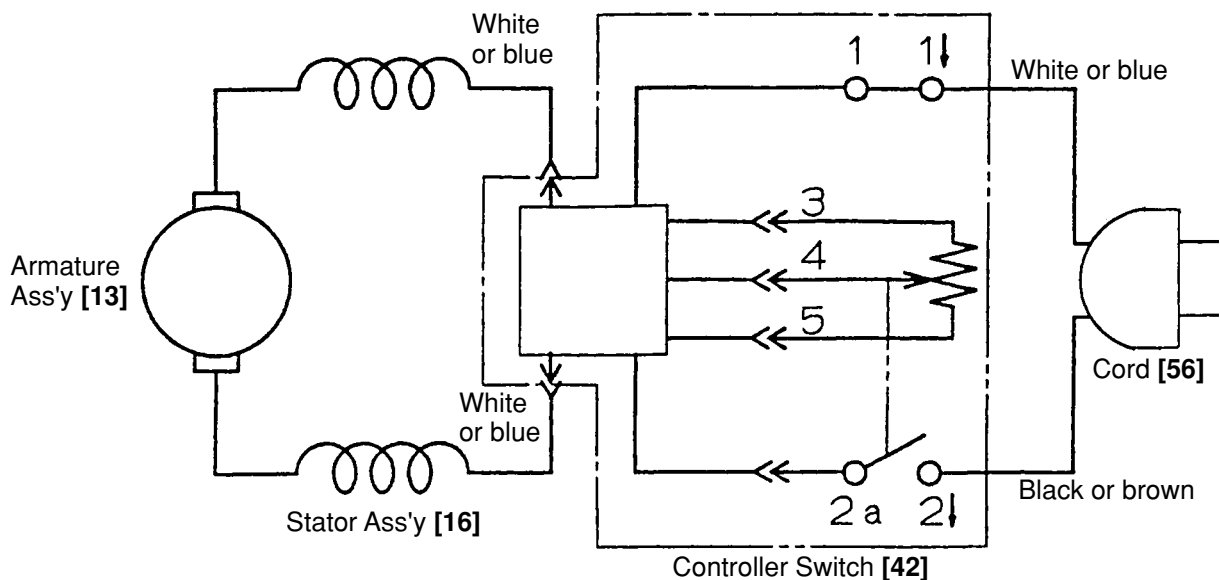

9-7. Insulation Tests

On completion of disassembly after repair, measure the insulation resistance and conduct the dielectric strength test.

Insulation resistance: 10 M Ω or more with DC 500V megohm tester

Dielectric strength test: AC 4,400 V for 1 minute, with no abnormalities 220 V – 240 V

AC 3,000 V for 1 minute, with no abnormalities 110 V – 120 V

9-8. Gear Backlash Value

Gear backlash should be maintained at a value of 2 mm or less measured at the outer edge of a fresh depressed center wheel.

9-9. No-Load Current Value

After no-load operation for 30 minutes, the no-load current value should be as follows.

Voltage (V)	110	120	220	230	240
Current (A) max.	6.8	6.8	3.9	3.9	3.9

10. STANDARD REPAIR TIME (UNIT) SCHEDULES

MODEL	Variable		10	20	30	40	50	60 min.
	Fixed							
SP 18VA		Work Flow						
	General Assembly				Armature Ass'y Gear Cover Ass'y Ball Bearing (6200DD) Ball Bearing (608VV) Dust Seal Felt Packing (B)			
				Needle Bearing Seal Packing Lock Pin	Gear		Ball Bearing (6202DD) Spindle Felt Packing (A) Packing Gland	
		Handle (B)		Handle (A) Control Switch Cord				

ELECTRIC TOOL PARTS LIST

ELECTRONIC SANDER POLISHER 2002 · 6 · 20
Model SP 18VA (E1)

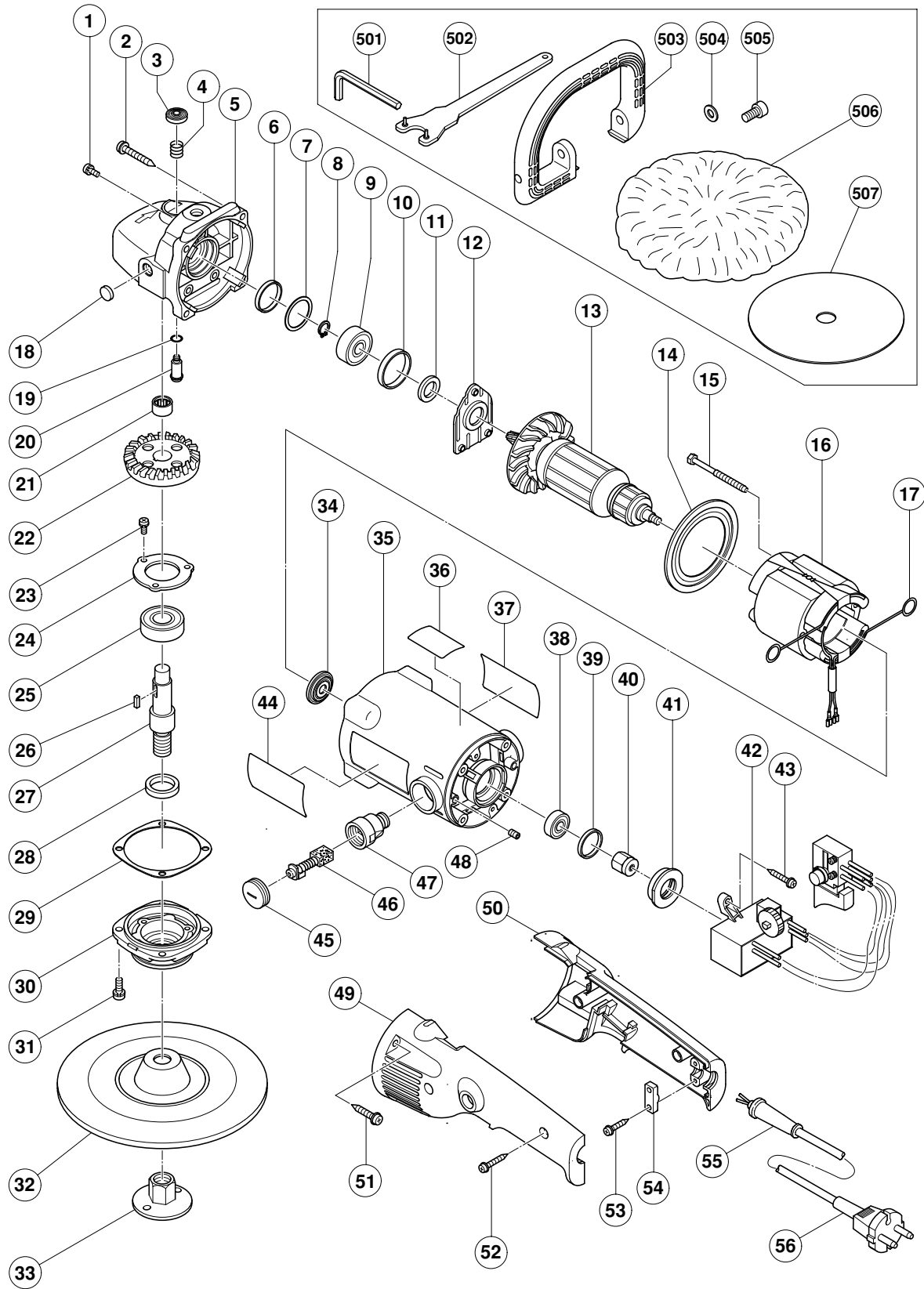

PARTS

SP 18VA

ITEM NO.	CODE NO.	DESCRIPTION	NO. USED	REMARKS	
1	303-255	SEAL LOCK SCREW (W/SP. WASHER) M4X10	3		
2	305-507	TAPPING SCREW (W/FLANGE) D5X30	4		
3	306-888	PUSHING BUTTON	1		
4	306-889	SPRING	1		
5	320-936	GEAR COVER ASS'Y	1	INCLUD.3,4,18-21	
6	315-055	SEAL RING (A)	1		
7	315-054	WASHER (A)	1		
8	939-540	RETAINING RING FOR D10 SHAFT (10 PCS.)	1		
9	620-0DD	BALL BEARING 6200DDCMPS2L	1		
10	315-053	RUBBER RING (A)	1		
11	315-052	FELT PACKING (B)	1		
12	315-051	BEARING COVER (B)	1		
*	13	360-576U	ARMATURE ASS'Y 110V-120V	1	INCLUD.9,11,34,38
*	13	360-576E	ARMATURE 220V-240V	1	
14	315-046	FAN GUIDE	1		
15	961-501	HEX. HD. TAPPING SCREW D5X60	2		
*	16	340-526C	STATOR ASS'Y 110V	1	INCLUD.17
*	16	340-526D	STATOR ASS'Y 120V	1	INCLUD.17
*	16	340-526E	STATOR ASS'Y 220V-240V	1	INCLUD.17
17	930-703	BRUSH TERMINAL	2		
18	315-049	FELT WASHER	1		
19	320-218	O-RING	1		
20	315-050	LOCK PIN	1		
21	871-397	NEEDLE BEARING (NTN HK1210)	1		
22	320-937	GEAR	1		
23	987-201	SEAL LOCK SCREW (W/SP. WASHER) M4X10	3		
24	937-077	BEARING COVER (A)	1		
25	620-2DD	BALL BEARING 6202DDCMPS2L	1		
26	940-533	FEATHER KEY 3X3X10	1		
*	27	320-943	SPINDLE	1	
*	27	320-944	SPINDLE	1	FOR USA,CAN
28	315-062	FELT PACKING (A)	1		
29	315-060	SEAL PACKING	1		
30	315-061	PACKING GLAND	1		
31	315-636	SEAL LOCK SCREW (W/SP.WASHER)M5X14(BLACK)	4		
*	32	953-255	RUBBER PAD (D16 HOLE)	1	
*	32	953-247Z	RUBBER PAD (D14 HOLE)	1	FOR USA,CAN
*	33	953-246Z	WASHER NUT M14	1	
*	33	953-254P	WASHER NUT 5/8"-11UNC	1	FOR USA,CAN
34	315-047	DUST SEAL	1		
35	320-945	HOUSING ASS'Y	1	INCLUD.39,41,47,48	
36	320-948	SETTING LABEL	1		
*	37	NAME PLATE	1		
38	608-VVM	BALL BEARING 608VVC2PS2L	1		
39	995-662	RUBBER RING	1		
40	318-721	MAGNET	1		
41	320-946	BEARING BUSHING	1		
*	42	320-941	CONTROLLER SWITCH	1	
*	42	320-940	CONTROLLER SWITCH	1	FOR GBR (110V),USA,CAN
43	305-095	TAPPING SCREW (W/FLANGE) D4X20	2		
44		HITACHI LABEL	1		

* ALTERNATIVE PARTS

6 - 02

PARTS

SP 18VA

ITEM NO.	CODE NO.	DESCRIPTION	NO. USED	REMARKS
45	945-161	BRUSH CAP	2	
46	999-043	CARBON BRUSH (1 PAIR)	2	
47	958-900	BRUSH HOLDER	2	
48	938-477	HEX. SOCKET SET SCREW M5X8	2	
49	320-939	HANDLE (B)	1	
50	320-938	HANDLE (A)	1	
51	302-089	TAPPING SCREW (W/FLANGE) D5X20 (BLACK)	4	
52	302-086	TAPPING SCREW (W/FLANGE) D4X20 (BLACK)	2	
53	984-750	TAPPING SCREW (W/FLANGE) D4X16	2	
54	937-631	CORD CLIP	1	
55	953-327	CORD ARMOR D8.8	1	
* 56	500-234Z	CORD	1	(CORD ARMOR D8.8)
* 56	500-435Z	CORD	1	(CORD ARMOR D8.8) FOR HKG,GBR (230V)
* 56	500-439Z	CORD	1	(CORD ARMOR D8.8) FOR NZL,AUS
* 56	500-396Z	CORD	1	(CORD ARMOR D8.8) FOR GBR (110V)
* 56	500-247Z	CORD	1	(CORD ARMOR D8.8) FOR NOR,SWE,DEN,FIN
* 56	500-447Z	CORD	1	(CORD ARMOR D8.8) FOR SUI
* 56	500-241Z	CORD	1	(CORD ARMOR D8.8) FOR USA,CAN

