

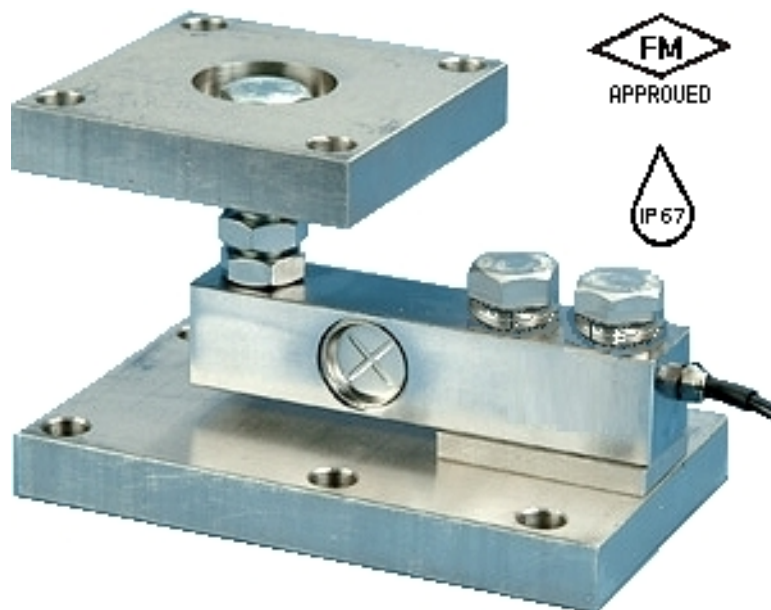

Installation Manual

Omnicell[®]

Model: 9106 FB



Amendment Record
Omnicell 9106 FB
DOCUMENT 51176

Manufactured by Fairbanks Scales Inc.
821 Locust Street
Kansas City, Missouri 64106

Created	08/2007	
Revision 0	08/2007	Preliminary Release
Revision 1	09/2007	Documentation Release
Revision 2	10/2007	Specifications Update

Disclaimer

Every effort has been made to provide complete and accurate information in this manual. However, although this manual may include a specifically identified warranty notice for the product, Fairbanks Scales makes no representations or warranties with respect to the contents of this manual, and reserves the right to make changes to this manual without notice when and as improvements are made.

It is the responsibility of the requesting party to develop, maintain, install, and connect networking devices and general network connectivity as it applies to the originating party's network. No warranty or guarantee, expressed or implied, concerning the network, its design, its installation, or operational characteristics has been offered by Fairbanks Scales. Fairbanks Scales shall not be liable for any loss, damage, cost of repairs, incidental or consequential damages of any kind, whether or not based on express or implied warranty, contract, negligence, or strict liability arising in connection with the design, development, installation, or use of an intended network.

© Copyright 2007

This document contains proprietary information protected by copyright. All rights are reserved; no part of this manual may be reproduced, copied, translated or transmitted in any form or by any means without prior written permission of the manufacturer.

Table of Contents

SECTION 1: GENERAL INFORMATION	6
Description.....	6
Features	6
Applications	6
<i>Dimensions (In Inches)</i>	7
<i>Wiring</i>	7
Specifications	8
SECTION 2: INSTALLATION.....	9
General Service Policies	9
<i>Phases of Installation</i>	9
<i>Conferring with Our Client</i>	9
<i>Pre-Installation Checklist</i>	10
<i>Unpacking</i>	10
<i>User's Responsibilities</i>	11
Installation	12
<i>Basic Assembly Steps</i>	12
<i>Omnicell® Placement</i>	13
SECTION 3: PARTS.....	14
<i>Omnicell® 9106 FB Complete Units</i>	14
<i>Load Cells</i>	14
<i>Parts Not Supplied</i>	15
<i>Omnicell 9106 FB Parts</i>	16

Section 1: General Information

DESCRIPTION

Fairbanks' Omnicell® 9106 FB Series is a single-ended beam weighing assembly. It is a cost-effective choice for medium-to-high capacity, non-commercial weighing applications requiring protection from extreme hostile and washdown environments.

FEATURES

- **Medium-to-High Weight Ranges.**
- Designed for **non-commercial applications.**
- **1,000 to 10,000 lb** capacity models.
- **Integral height adjustment** on the receiver plate for easy load balancing.
- Articulating mounting plate which **accommodates non-planar misalignments** of up to four degrees (4°).
- Load Cells constructed from **17-4 PH Stainless Steel Load Cells.**
- Mount constructed with **304 Stainless Steel.**
- Low profile design with integral height adjustment.
- **Factory Mutual** approved for hazardous applications.

APPLICATIONS

- | | | |
|------------------------|-----------|------------|
| • High Accuracy | • Tanks | • Bins |
| • Process Reactors | • Mixing | • Blending |
| • Hostile Environments | • Hoppers | • Batching |

Dimensions (In Inches)

CAPACITY	A	B	C	D	E	F	G	H	I
1,000-5000 lbs.	7.12	4.00-4.50	5.00	0.56	2.00	4.00	0.70	4.00	0.63
10,000 lbs.	8.50	5.00-5.50	5.00	0.75	3.00	4.00	0.94	5.00	0.69

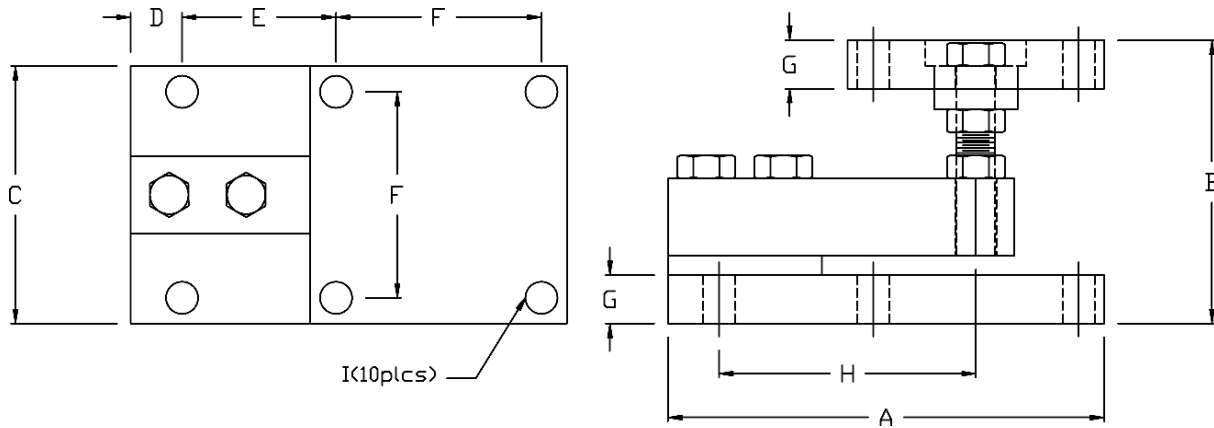

Wiring

CABLE CODE	
Green	(+) Excitation
Black	(-) Excitation
White	(+) Signal
Red	(-) Signal

SPECIFICATIONS

Capacities	1,000, 1,500, 2,500, 5,000, and 10,000 lbs.
Mount Construction	304 Stainless Steel
Full Scale Output (FSO)	3.0mV/v \pm 0.25%
Combined Error (FSO)	\leq 0.03%
Non-Linearity (FSO)	\leq 0.03%
Hysteresis (FSO)	\leq 0.02%
Creep Error (30 min.)	\leq 0.03%
Compensated Temperature	14° to 104° F (-10° C to 40° C)
Operating Temperature	-40° to 176° F (-40° to 80° C)
Excitation Voltage	5-15 VDC
Mechanical Overload	<ul style="list-style-type: none"> • Safe = 150% • Ultimate = 300%
Sideload	Safe = 100%
Bridge Resistance	350 ohms nominal
Load Cell Construction	Stainless Steel 17-4 PH
Sealing	Welded Seal
Cable	20 ft. Polyurethane
Protection	IP 67
Approvals	Factory Mutual Approved

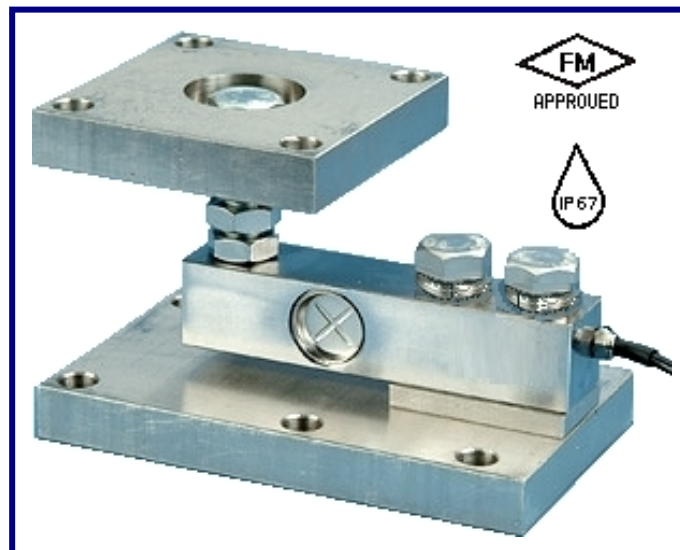

Section 2: Installation

GENERAL SERVICE POLICIES

Phases of Installation

1. Verifying the application
2. Unpacking & equipment checkout
3. Installation & adjustments
4. Customer check-off and site readiness

Conferring with Our Client

- The lead tech must be prepared to recommend the arrangement of components which provide the most efficient layout, utilizing the equipment to the best possible advantage.
- The warranty policy must be explained and reviewed with the customer.

Pre-Installation Checklist

The following points should be checked and discussed with the **Area Sales Manager and/or customer**, if necessary, before the technician goes to the site and installs the equipment.

- ✓ Check the customer's application to make certain it is within the capabilities and design parameters of the equipment.
- ✓ If the installation process might disrupt normal business operations, tell the customer and ask that they make ample arrangements.
- ✓ Is properly-grounded power available at the installation location?
- ✓ Be sure that the equipment operator(s) are available for training.
- ✓ The service technician must thoroughly review the installation procedures.
- ✓ The service technician reviews the recommended setup with the Area Sales Manager or Area Service Manager, and together they identify all necessary variations to satisfy the customer's particular application.



Unpacking

Follow these guidelines when unpacking all equipment:

- ✓ Check in all components and accessories according to the customer's order.
- ✓ Remove all components from their packing material, checking against the invoice that they are accounted for and not damaged.
 - *Advise the shipper immediately, if damage has occurred.*
 - *Order any parts necessary to replace those which have been damaged.*
 - *Keep the shipping container and packing material for future use.*
 - *Check the packing list.*
- ✓ Collect all necessary installation manuals for the equipment and accessories.
- ✓ Open the equipment and perform an inspection, making certain that all hardware, electrical connections and printed circuit assemblies are secure.
- ✓ Do not reinstall the cover if the final installation is to be performed after the pre-installation checkout.



User's Responsibilities

1. All electronic and mechanical calibrations and or adjustments required for making this equipment perform to accuracy and operational specifications are considered to be part of the installation.
 - They are included in the installation charge.
 - Only those charges which are incurred as a result of the equipment's inability to be adjusted or calibrated to performance specifications may be charged to warranty.
2. Absolutely no physical, electrical or program modifications other than selection of standard options and accessories are to be made to this equipment.
 - ***Replacement of individual components is not allowed.***
 - The assemblies must be properly packaged in ESD protective material and returned intact for replacement credit per normal procedures.



INSTALLATION

Basic Assembly Steps

1. **Raise the vessel** that is to be supported by the Omnicell® Assemblies.
2. Secure the Assembly by safely **placing blocks under the vessel** to the required height.
3. **Place each Assembly onto a level surface** under each support leg.
4. Set the Assemblies for the **correct load cell orientation** (*as shown on the following page*).
5. **Insert the four (4) 1/2-13 bolts** (5,000 capacity and under) or **5/8-11 bolts** (10,000 capacity), and then **fasten them loosely** to the support leg for each assembly.
6. **Mark the location** of the anchor bolt locations.
7. Slide the assembly back and **drill the anchor hole locations**.
8. Re-position the load cell assemblies, level, and **install the anchor assemblies**.
9. **Lower the vessel** onto the top plate of each Omnicell® Assembly.
10. **Tighten the bolts**, securing the load plates to each support leg of the vessel.
11. **Remove all cribbing blocks**.
12. **Route the cables** to the junction box and indicator.
13. **Wire the Omnicell® Assemblies** according to the appropriate junction box and indicator service manual.

Before the installation is considered complete, the equipment is to be configured to meet or exceed any applicable weights and measures requirements.

Omnice[®] Placement

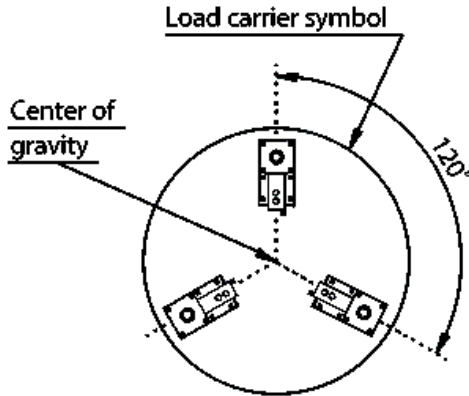

Figure 1

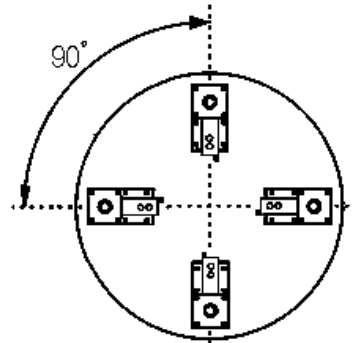

Figure 2

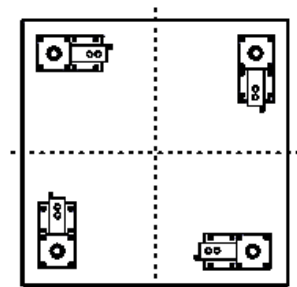

Figure 3

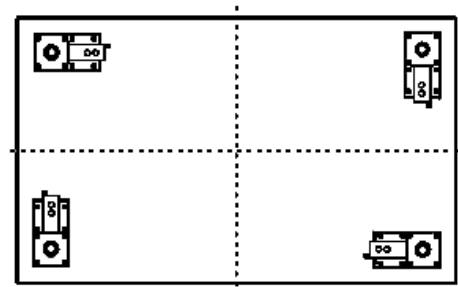

Figure 4

Follow these guidelines for installing Omnicell[®] Load Cells.

1. The loading points of the modules should be as far from one another as the structure allows.
2. When installing the square and rectangle Omnicell units, line up the **Base Plates** of the Load Cells with each other, and align them evenly from the end and the sides of the units.
3. When installing six Load Cells (*Figure 5*), **be extremely careful** to position the center Omnicells[®] to exactly the same height as the outer Omnicells[®].

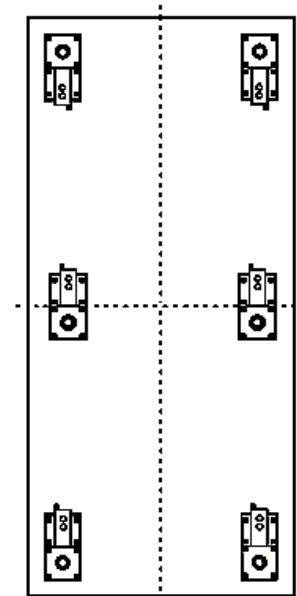

Figure 5

Section 3: Parts

Omnicell[®] 9106 FB Complete Units

Part No.	Description
27886	Omnicell, w/ Fabricated SS Mount, SS Welded Load Cell 1,000 lb. Capacity
27887	Omnicell, w/ Fabricated SS Mount, SS Welded Load Cell 1,500 lb. Capacity
27888	Omnicell, w/ Fabricated SS Mount, SS Welded Load Cell 2,500 lb. Capacity
27889	Omnicell, w/ Fabricated SS Mount, SS Welded Load Cell, 5,000 - SE Capacity
27890	Omnicell, w/ Fabricated SS Mount, SS Welded Load Cell, 10,000 Capacity

Load Cells

Part No.	LCF Number	Description
27906	LCF-9100-27	Stainless Steel Welded Shear Beam Load Cell, 1,000 lb. Capacity
27907	LCF-9100-28	Stainless Steel Welded Shear Beam Load Cell, 1,500 lb. Capacity
27908	LCF-9100-29	Stainless Steel Welded Shear Beam Load Cell, 2,500 lb. Capacity
27909	LCF-9100-30	Stainless Steel Welded Shear Beam Load Cell, 5,000 - SE Capacity
27910	LCF-9100-31	Stainless Steel Welded Shear Beam Load Cell, 10,000 lb. Capacity

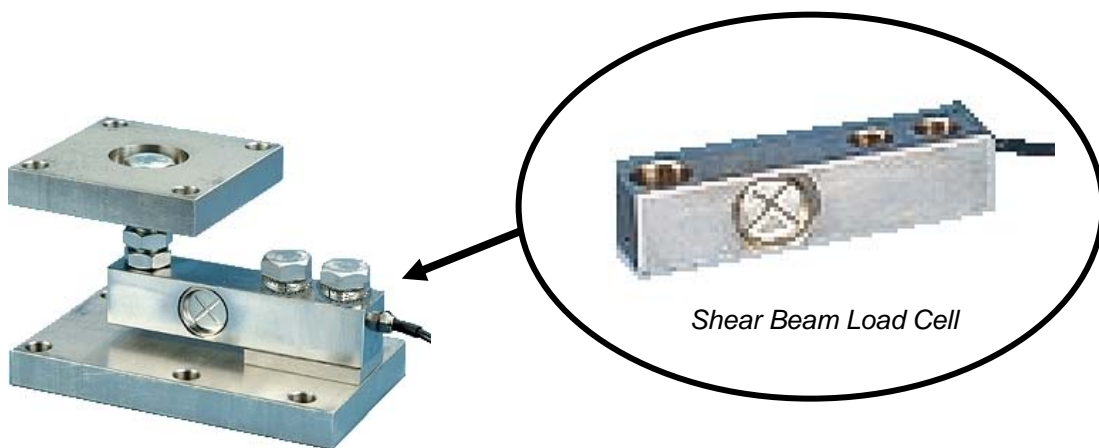

9106 FB Series Omnicell[®]

Parts Not Supplied

Qty. Per Ass'y	Components
	<i>Fastening Bolts for Vessel Attachment</i>
4	▪ <i>1/2 -13 UNC bolts (5,000 capacities and under)</i>
6	▪ <i>1/2 -13 UNC Anchor Bolts (5,000 capacities and under)</i>
4	▪ <i>5/8 -11 UNC bolts (10,000 capacity)</i>
6	▪ <i>5/8 -11 UNC Anchor Bolts (10,000 capacity)</i>

Omnicell 9106 FB Parts

Fairbanks P/N	Diagram Letter	Qty	Components
93648		1	9106 FB Mounting Ass'y (1,000 lbs to 5,000-SE)
			<i>Assembly includes the following parts (without a load cell).</i>
	A	1	▪ SS Base Plate
	B	1	▪ SS Top Plate
	C	1	▪ SS Load Cell Shim Spacer
	E	1	▪ Hex Bolt, 1/2-13 2.25"
	F	2	▪ Lock Washer 1/2", Split Ring
	G	1	▪ Box Hex, 1/2-20 3.0" Full Thread
	H	1	▪ Spherical Washer Set, 1/2"
	I	2	▪ Nut 1/2-20

93649		1	9106 FB Mounting Ass'y (10,000 lbs)
			<i>Assembly includes the following parts (without a load cell).</i>
	A	1	▪ SS Base Plate
	B	1	▪ SS Top Plate
	C	1	▪ SS Load Cell Shim Spacer
	E	1	▪ Hex Bolt, 3/4-10 3.0"
	F	2	▪ Lock Washer, 3/4", Split Ring
	G	1	▪ Box Hex, 3/4-16 3.5" Full Thread
	H	1	▪ Spherical Washer Set, 3/4"
	I	2	▪ Nut 3/4-16

* Item(s) not shown on diagram.

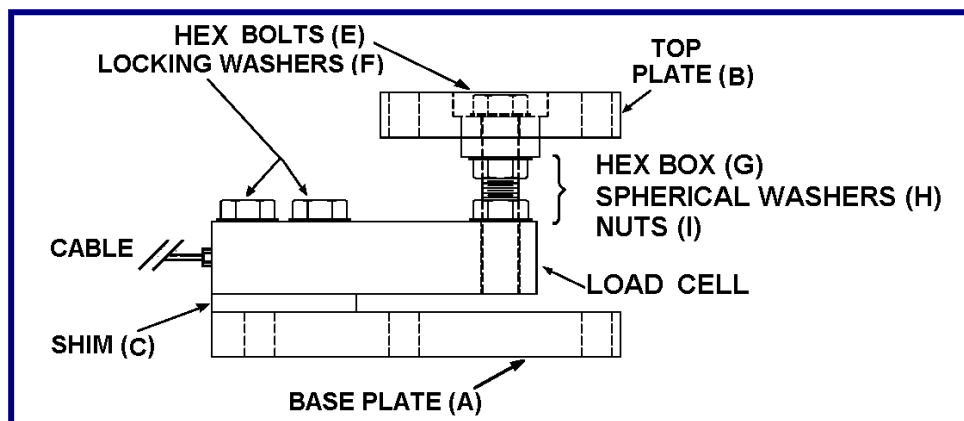



Manufactured by Fairbanks Scales, Inc.
821 Locust Street
Kansas City, Missouri 64106
www.fairbanks.com

Omnicell[®]

Model: 9106 FB
INSTALLATION MANUAL

DOCUMENT 51176