

**TR3301**  
**Tissue Vending Machine**

# **User Manual**

**Panda Vending Limited**  
[www.pandavending.com](http://www.pandavending.com)



## **Preface**

Welcome to use our vending machine! Before you install and operate this machine, please read the manual carefully. In order to make good use of superior performance of the machine, we strongly recommend you install and maintain it strictly following the instruction of the manual. And keep this manual for your future reference.

If you have any question about operation or service, feel free to contact us.



## Contents

Preface.....	1
Appearance and components.....	2
Installation and operation.....	3
Troubleshooting .....	9
Technical specifications.....	11

## Appearance and components

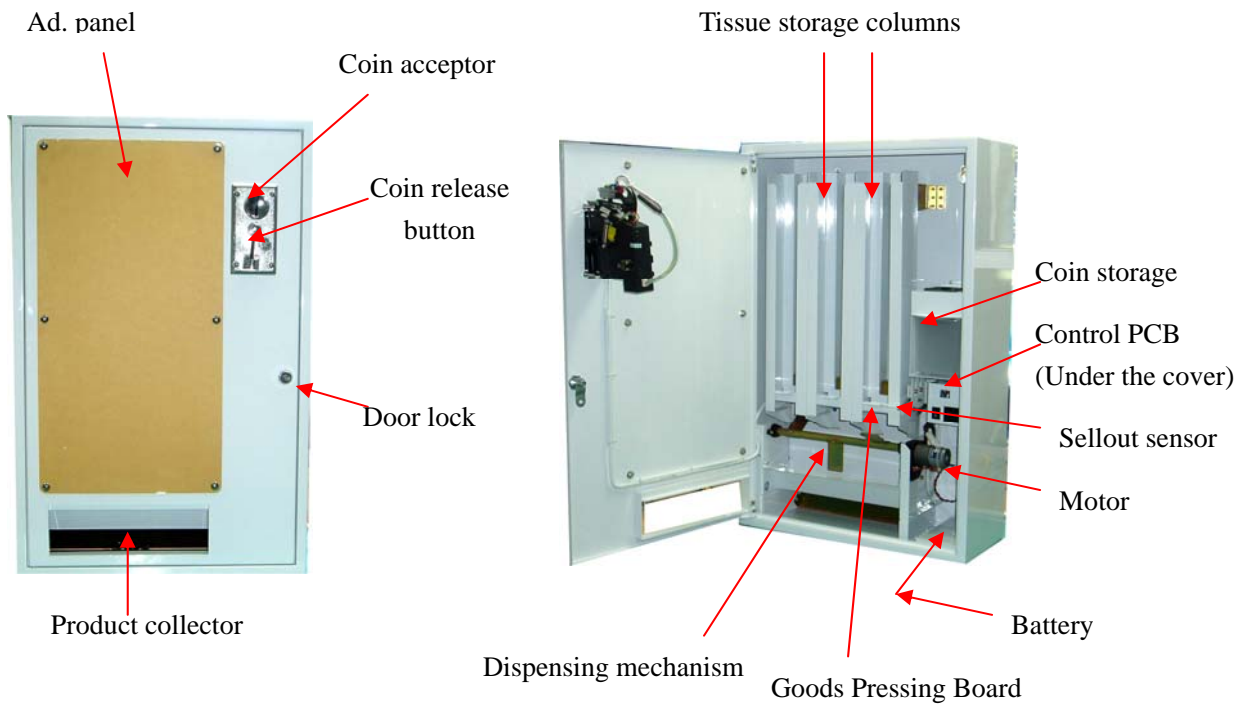

Front View

Inside View

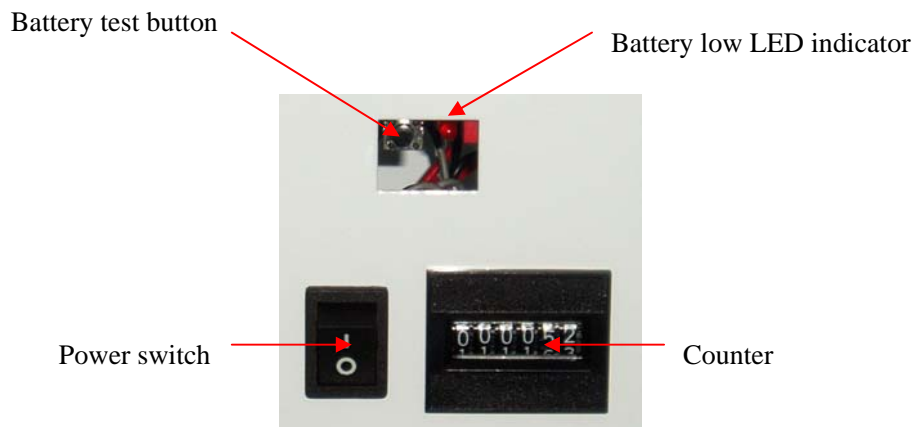

Control Panel

**Note:** there is possibly the difference between the pictures and the practres and the real machine and the appearance is as per the real machine please.



## Installation and operation

**Note:** In order to use this machine safely, ensure its good operation and better being maintained, be sure to carefully read and strictly follow the manual before the installation and use of this machine.

### I. Installation

#### i. Caution

- The machine should be installed firmly on solid wall
- The machine shouldn't be installed in the wet or dusty area
- The machine should be installed near the lamp-house so that it can be used at night

#### ii. Tools & materials needed

- Electrical drill with a drilling bit (diameter 12mm, for drilling holes on the wall)
- Four bulgy screws (M8, or similar size)
- Sleeve wrench suitable for M8 nuts (or similar size nuts)
- Cross screwdriver

#### iii. Mount the machine

- Choose a wall with flat surface which can bear the weight of the machine
- Drill four holes on the wall at an appropriate height (the height should be suitable for easy operating of the machine, distances between the holes refer to the picture followed on next page)
- Insert bulgy screws into the holes
- Put the machine on the bulgy screws (through the holes on the back of the metal case of the machine)
- Put on the gaskets and nuts then fasten the nuts of the bulgy screws
- Check whether the machine has been mounted firmly

#### iv. Ad Paper Installation

- Remove six nuts on the rear of the door
- Unload the transparent Ad pressing plate
- Put on the ad. Paper and use the plate to tightly press the Ad paper on the front surface of the door
- Fasten the six bolts back.

**Size of Ad. paper:** 520mm long and 270mm wide

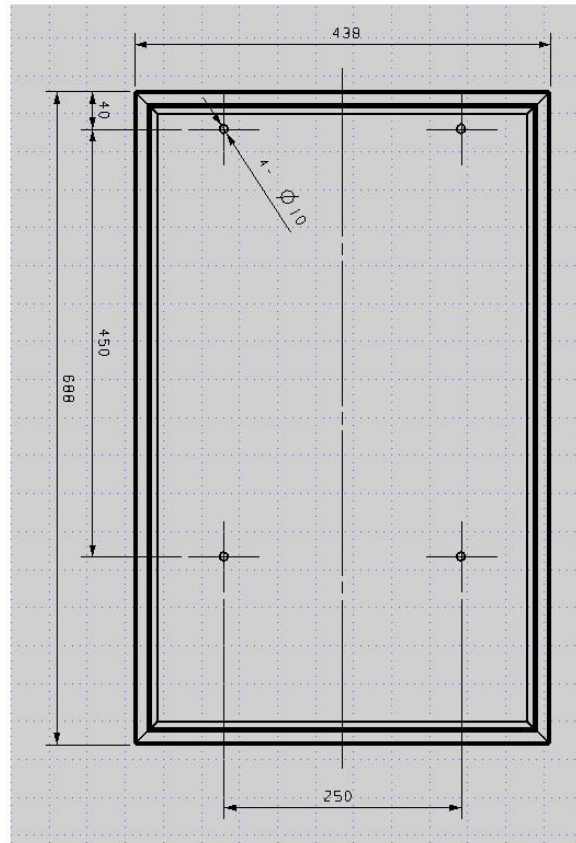

### Installation holes on the back

#### v. Battery installation

**Note:** When leaving the factory, the anode and cathode of the battery will not be connected. Before installing the battery, it must be recharged and checked whether it can work very well.

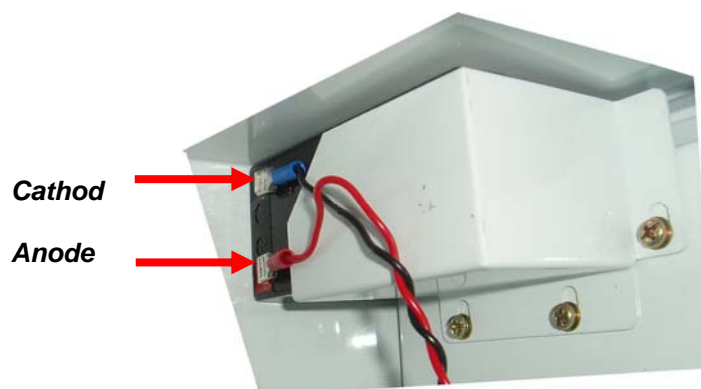

### Battery Position (Bottom right corner inside the machine case)

#### Caution:

If the battery was not installed on right position and connected wrongly, it could cause leaking that is dangerous and harmful to the machine and human.

## vi. Sample Coin Installation

This machine uses a comparative coin detector, so a real coin that is the same as the coins you want the machine to accept must be installed on the coin detector before using.

When installing sample coin, pull the sample coin holder upward and put the sample coin into the slot carefully. (Refer to the following illustration).

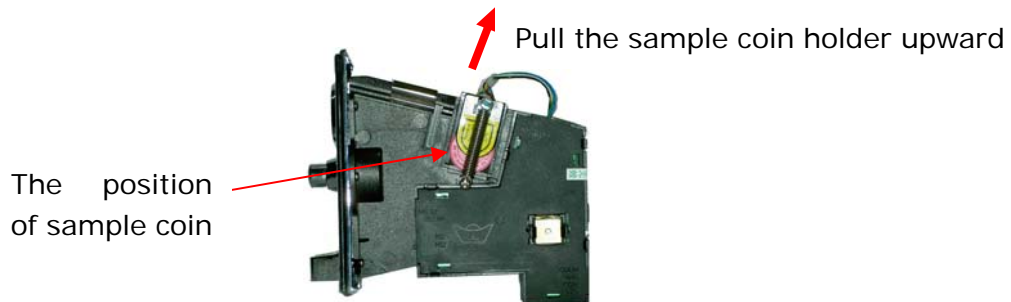

### Installing sample coin

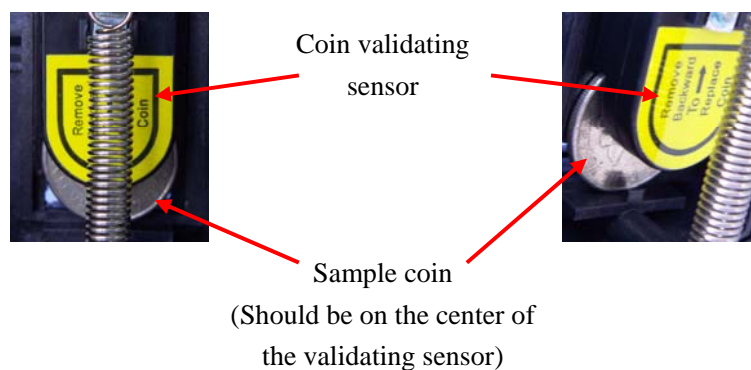

### Sample coin installed

After the installation of the sample coin finished, the coin acceptor should be tested with the true coins repetitiously. (Each time one piece of product will come out after inserting two pieces of £1 coins), If the motor can act after inserting the coin each time, it means that the sample coin has been installed properly and this machine is ready to use. During the test, if you find the coin acceptor always refuses the coins, pls change another coin as a sample one.

It is normal that a valid coin cannot be accepted occasionally. But it indicates the sample coin is not installed properly if the coins are refused frequently. In this situation, adjust the sample coin's position appropriately to make sure it is on the central area of the sensor with its bottom clipping in the groove. If it still doesn't work well, try to change the pose of the sample coin, push it on the left side closely or make its top leaning to the right side of the coin clipping groove of the sensor (near the spring as the illustration followed). Usually, it is better to push the sample coin on left side for thick coins, and leaning to the right side would be better for thin coins.

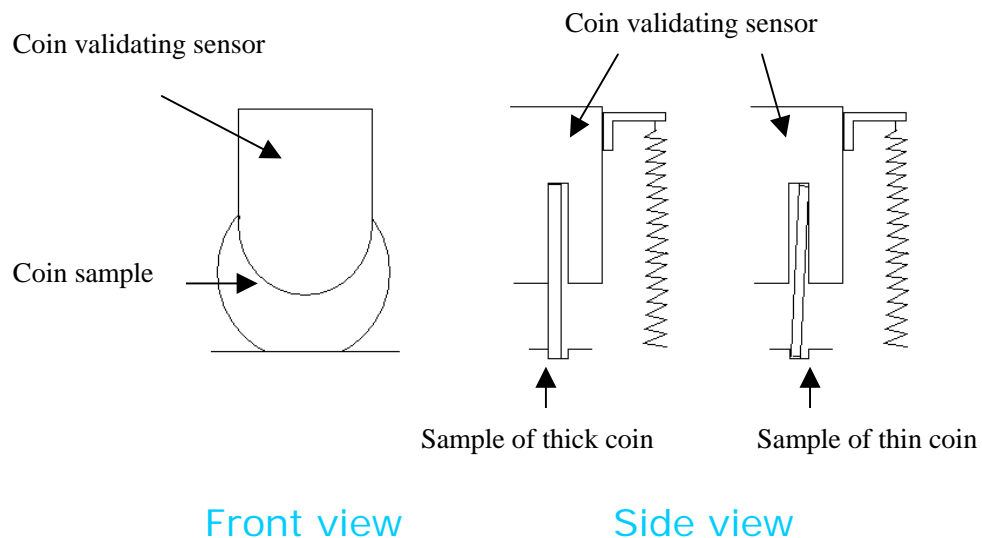

## II. Operating the machine

Before using the machine, please check whether all the parts are included and there are two keys, three pieces of pressing boards except the whole machine.

The setting switch 1, 2, 3 and 4 on PCB board are showed as the right picture. When switch 1 is set to "ON" position, it means during making a transaction one coin is for one pack, when switch 2 is set to "ON" position, it means two coins are for one pack, the rest switch 3 and 4 are deduced by analogy.



### i. Add goods

Each column in this machine is designed in a definite specification given by customers when ordering. Please add the tissues with same size as which you gave us when you ordering the machine. Adding wrong size of the tissues could cause unnecessary troubles.

To add tissues, please remove the pressing boards in each column first, then stack new tissue packs into the columns. Be sure that the stack level of each column should be almost the same, because the tissues in each column will be dispensed by turns.

The pressing boards should be put on the top of tissues in each column after the



tissues has been loaded in the columns. Make sure the pressing board with long handle should be put on the column at right end. It is important for sellout detection. Please refer to the following illustration.

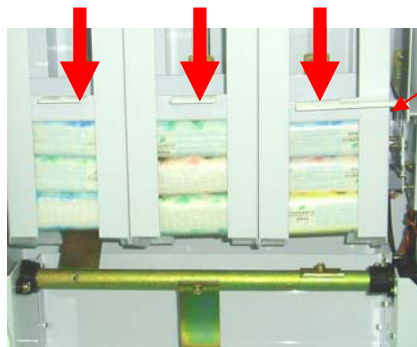

The pressing board with long handle for sellout detection

*Note: In order to avoid the unnecessary trouble, don't put some rugged, damaged pack or worn tissue in the column.*

## ii. Vending operation

The sequence of vending operating is illustrated as below.

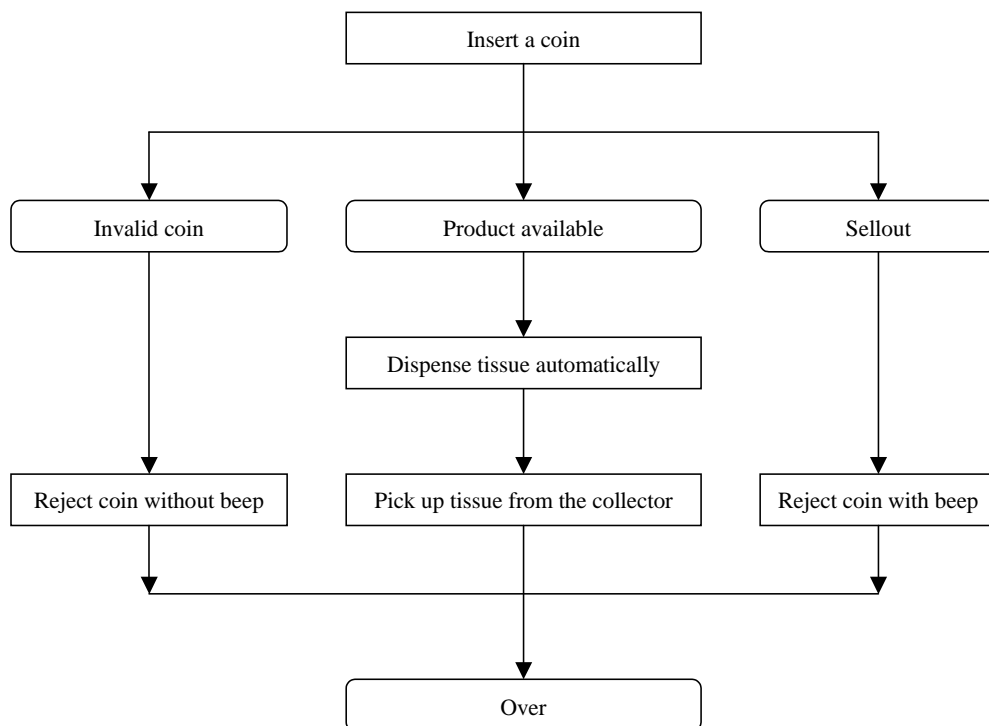

### Note:

1. When the machine is setting into the fact that multi-coins are for only one pack of product, please tell the customer that the machine will not return the coin to him even if he doesn't want to buy the product after inserting one coin and one pack of product will be dispensed out until the customer inserts enough coins.
2. When the coin whose size is more than the specified one is inserted into the coin validator, it will be jammed and please press the coin return button to get back the coin.



## Maintenance

This machine is operated by battery. So the maintenance of the machine will focus on the battery because it is critical for the functionality of the machine.

Every time when adding tissues or collecting coins, the machine should be checked by doing a few purchasing operations. Another task should be done is the battery checking. A low battery will cause the machine works un-properly.

### I. Check battery

The battery checking function has been integrated in the machine for convenient maintenance. To check whether the battery low occurs, the only task to do is pressing the battery test button on the control panel. If the voltage is too low, the LED indicator beside the button will keep lighting when the button being pressed, it means the battery should be recharged. If LED just flashes once or keeps dark when the button is pressed down, it means the voltage is normal.

**Notes:**

- a) Technical parameters:  
Capacity: 12V 1.2AH; Voltage when full:13.2V  
Voltage when receiving a recharging prompt from the system:12.5V  
Voltage when the system cannot start:≤12.2V
- b) Please use the charger equipped by the machine manufacturer or the similar one to recharge the battery. When it is full, you have to powder off the charger to avoid over-recharge the battery.
- c) Please recharge the battery before using the machine or when talking it out to use from the stock because the stored battery often discharges automatically.
- d) The battery should stand rightly, not upside down or on the side.
- e) If the system cannot start, please check whether the battery works normally.

### II. Recharge battery

The machine uses a 12V rechargeable storage battery. So a charger that is specially designed for 12V storage battery should be used to recharge the battery. The chargers with three phases recharging control are strongly recommended for assuring the recharging safety and battery lifetime. This kind of charger products can be found easily from the market.

## Troubleshooting

Some additional information useful for the troubleshooting is given firstly for your reference in following pictures.

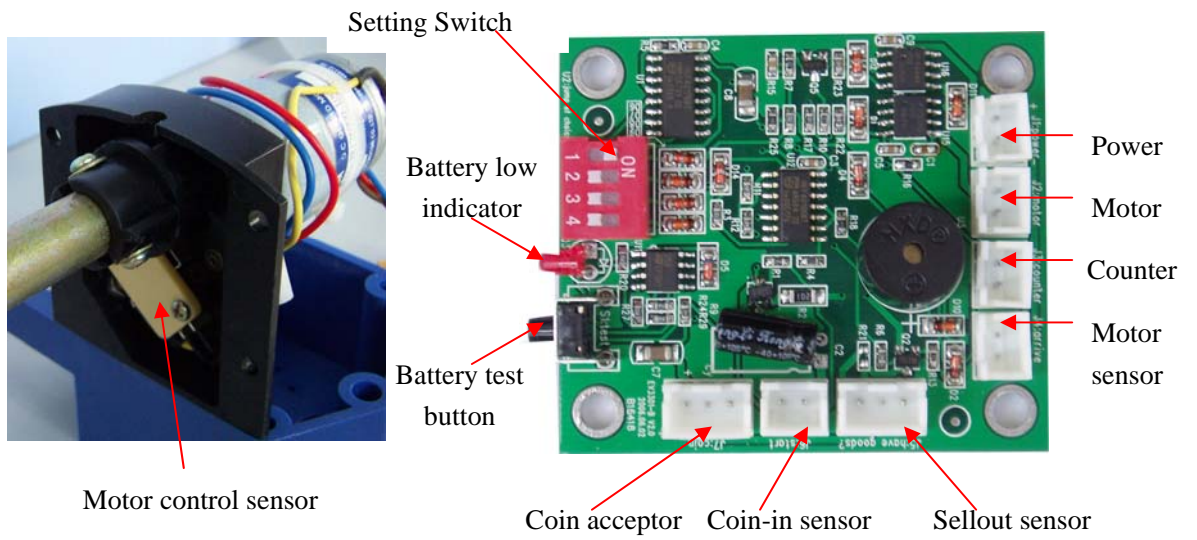

Motor assembly

Connectors on PCB

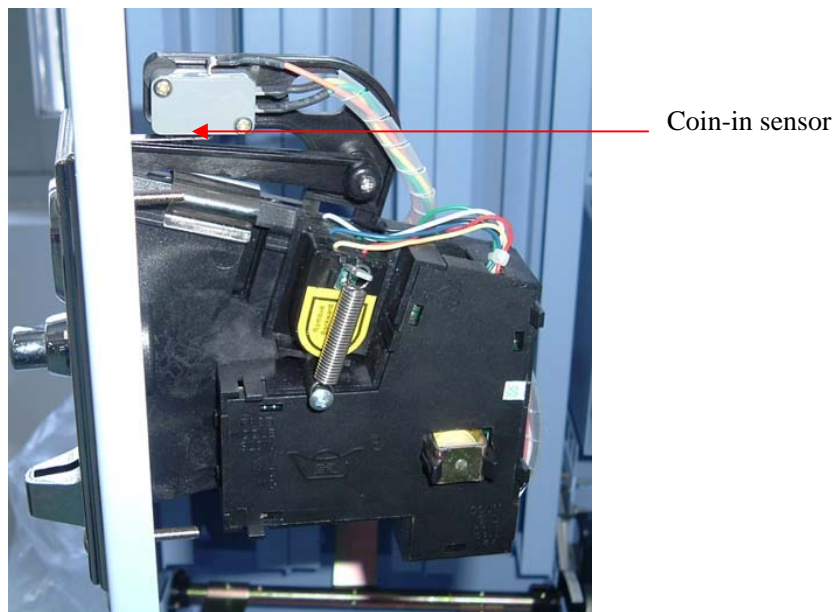

Coin acceptor assembly

**Note:** Be sure don't put your hands, tools or other things into the dispensing mechanism to avoid hurting you or damaging the machine.

Problems	Causes	Solution
No response after turning on	1. Battery plugs un-plugged	Put on the plugs
	2. Battery is empty	Replace the battery with new one or recharge the battery
	3. Sellout sensor is wrong	Replace the sensor
	4. Connectors on the control PCB are loosed	Firmly put the connectors on the right positions
	5. PCB is wrong	Replace PCB with new one
Dispensing mechanism doesn't work properly	1. The motor is wrong	Replace the motor with a new one
	2. The connector on the PCB for motor loosed	Put on the connector firmly
	3. Motor control sensor is wrong	Replace the sensor with a new one
	4. Motor control sensor on wrong position or loosed	Adjust the sensor position and fix it firmly
	5. Battery low	Recharge the battery
	6. PCB is wrong	Replace PCB with new one
Coin acceptor doesn't work properly	1. Coin slot is jammed	Get rid of the rarity
	2. The connector on the PCB for coin acceptor loosed	Put on the connector firmly
	3. Coin-in sensor is wrong	Replace the sensor with a new one
	4. Coin-in sensor on wrong position	Adjust the sensor position
	5. Coin acceptor is wrong	Replace the coin acceptor with new one



## Technical Specifications

Item	Performance parameters
Dimension	688mm (H) x 438mm (W) x 185mm (D)
Weight	20KG
Ambient temperature and humidity	0~40°C, 10%~85%
Pack dispensing speed	Less than 3 seconds
Battery	12V rechargeable storage battery
Coin acceptable	Configurable
Coin capacity	Over 300pcs
Tissue capacity	40~60 packs (Configured upon order)
Counter	6 decimal digits

Thank you for your choosing our products again.

©2006 E-BIZ2CHINA LIMITED. All rights reserved