

Installation & Operating Manual

The Harman DVC-500 Coal Stoker

HARMAN[™]
HOME HEATING

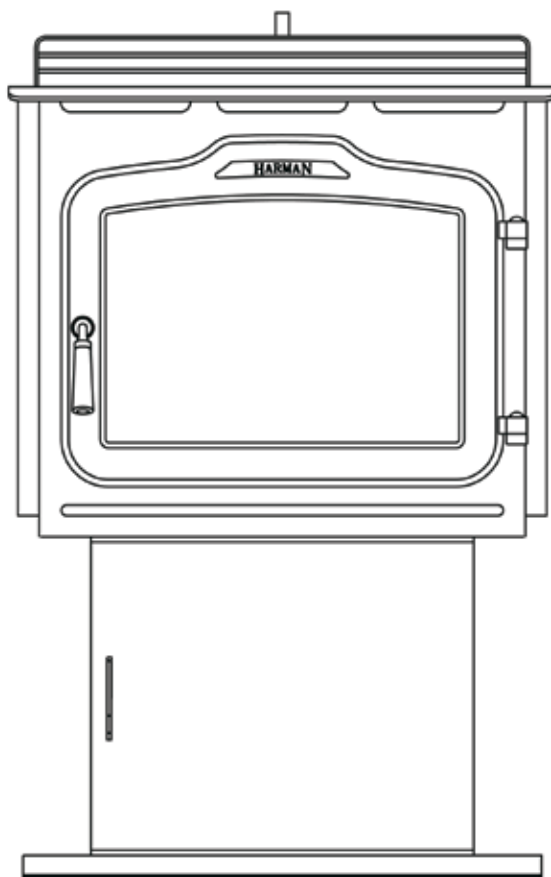

We suggest that our hearth products be installed and serviced by professionals who are certified in the U.S. by the National Fireplace Institute (NFI) as NFI Specialists.



Intertek R15

SAFETY NOTICE

PLEASE READ THIS ENTIRE MANUAL BEFORE YOU INSTALL AND USE YOUR NEW ROOM HEATER. FAILURE TO FOLLOW INSTRUCTIONS MAY RESULT IN PROPERTY DAMAGE, BODILY INJURY, OR EVEN DEATH.

SUITABLE FOR INSTALLATION IN MOBILE HOMES.

IF THIS HARMAN STOVE IS NOT PROPERLY INSTALLED, A HOUSE FIRE MAY RESULT. FOR YOUR SAFETY, FOLLOW INSTALLATION DIRECTIONS.

CONTACT LOCAL BUILDING OR FIRE OFFICIALS ABOUT RESTRICTIONS AND INSTALLATION INSPECTION REQUIREMENTS IN YOUR AREA.

CONTACT YOUR LOCAL AUTHORITY (SUCH AS MUNICIPAL BUILDING DEPARTMENT, FIRE DEPARTMENT, FIRE PREVENTION BUREAU, ETC.) TO DETERMINE THE NEED FOR A PERMIT.

DO NOT USE MAKESHIFT COMPONENTS OR OTHER COMPROMISES DURING INSTALLATION OR SERVICE.

SAVE THESE INSTRUCTIONS.

#3-90-08311



**LISTED SOLID FUEL BURNING ROOM
HEATER - MODEL: "DVC 500"**



Intertek
W/N 03625

Serial Number: **WHI-**

TESTED TO: ASTM E1509, and parts of UL127
TEST DATE: July, 1996
APPROVED FOR USE IN MANUFACTURED HOMES.

DO NOT REMOVE THIS LABEL.

PREVENT HOUSE FIRES: KEEP DOORS AND HOPPER LID CLOSED DURING OPERATION. INSTALL AND USE ONLY IN ACCORDANCE WITH MANUFACTURER'S INSTALLATION AND OPERATING INSTRUCTIONS. CONTACT LOCAL BUILDING OR FIRE OFFICIALS ABOUT RESTRICTIONS & INSTALLATION INSPECTION REQUIREMENTS IN YOUR AREA. SEE THE INSTALLATION MANUAL AND CHECK WITH YOUR LOCAL CODES FOR SPECIAL INSTRUCTIONS WHEN PASSING THE VENT THROUGH A COMBUSTIBLE WALL OR CEILING.

UNIT MUST BE PLACED ON A NON-COMBUSTIBLE FLOOR OR FLOOR PROTECTOR EXTENDING 16" TO THE FRONT, 8" TO THE SIDES AND 3" TO THE REAR. MINIMUM 24 GA SHEET METAL.

DIRECT-VENT - USE ONLY HARMAN DVC-VENTING COMPONENTS FROM THE APPLIANCE THROUGH THE OUTSIDE WALL. USE ONLY 4" TYPE L OR PL PELLET VENT ON THE OUTSIDE OF HOME.

DO NOT CONNECT TO A CHIMNEY. DO NOT CONNECT THIS UNIT TO A CHIMNEY OR FLUE SERVING ANOTHER APPLIANCE.

FUEL: ANTHRACITE RICE COAL ONLY. THE EPA PROHIBITS THE USE OF ANY OTHER FUEL, EXCEPT FOR COAL IGNITION.

INPUT RATING: 6 POUNDS PER HOUR.

ELECTRICAL RATING: 2.5 AMPS, 120 VOLTS, 60 HERTZ.

REPLACE GLASS WITH ONLY 5 MM CERAMIC.

INSPECT AND CLEAN EXHAUST VENTING SYSTEM FREQUENTLY.

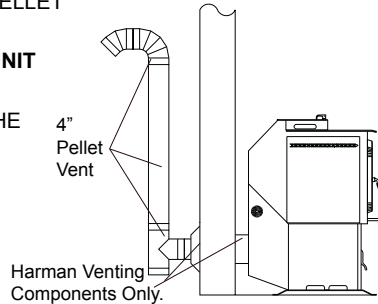

MINIMUM CLEARANCES TO COMBUSTIBLES:

- UNIT TO SIDE WALL - 18"
- UNIT TO REAR WALL - 3"
- STOVE TOP TO CEILING - 24"
- CORNER INSTALLATION - 9"

FLOOR PROTECTION:

- FRONT - 16"
- SIDES - 8"
- REAR - 3"

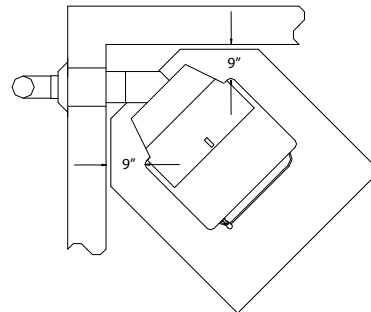
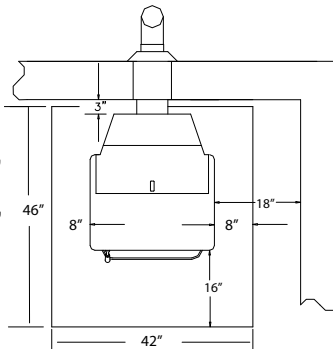

Date of Manufacture:
2010 2011 2012 JAN FEB MAR APR MAY JUN JUL AUG SEP OCT NOV DEC



Manufactured by: Harman Home Heating 352 Mountain House Road, Halifax PA 17032

3-90-08210

This appliance is also approved for installation into a shop.

INDEX

Warnings	4
Introduction	5
Assembly	6
Installation	7
DVC500 Microprocessor Control	15
Operation	17
Maintenance	19
Fuel	23
Wiring Diagram	25
Control and Safety Sensors	26
Parts	27
Specifications	30
Troubleshooting	31

Please read this entire manual before you install and use your new room heater. Failure to follow instructions may result in property damage, bodily injury, or even death.

SUITABLE FOR MOBILE HOME INSTALLATIONS.

SAVE THESE INSTRUCTIONS

Harman Home Heating
352 Mountain House Road
Halifax, PA 17032
harmanstoves.com

Carbon Monoxide (CO) Awareness

Carbon monoxide, referred to as CO, is a colorless, odorless gas that is produced during combustion of coal and other fuels. **CO fumes are toxic and can be fatal.**

The DVC 500 is a closed loop system specially designed to prevent the escape of CO and other combustion products from the stove.

Even though this stove is designed to be as safe as possible, it is important that you **install a CO detector**. This is true for oil, gas, or wood burning products as well.

CO detectors are very sensitive and may sound an alarm for fumes other than CO or CO from sources other than the stove such as car or lawn mower exhaust.

If the alarm sounds

1. Increase ventilation by opening windows or doors.
2. Make sure the stove doors and hopper lid are closed and latched.
3. Check stove for electrical power and normal operation.
4. Check for false alarm.

(Never sleep in the same room with any coal burning stove.)

Wet Coal

Freshly delivered coal is watered down to eliminate dust when loading and unloading. Wet rice coal does not flow as well as damp or dry coal. We do not recommend burning wet coal; however, we realize if it's the only coal you have, it is better to burn it than be cold. If you must burn wet coal, the feed rate must be increased in order to get the same size fire. As the wet coal in the hopper dries out, the feed rate must be decreased. Loading wet coal once or twice a year will not damage your stove as long as it is hot and burning. The damage is caused when the hopper has wet coal in it when the stove is cold. This will cause rust and corrosion and it is totally the operator's fault. Usually after the coal dries for three or four days, depending on conditions, it will flow very well and feed properly. Feed rate will be the same as with dry coal.

Always Empty Hopper

Always empty the hopper when not burning for more than a week. When left standing for long periods with wet coal, the pusher block will rust and corrode, causing it to seize. If the stoker is then turned "on", damage to the pusher assembly and feed motor could result. This will be considered neglect and will void the warranty on those parts. Always check to see that moving parts are free before using, if the unit has not been burned for a period of time. This can best be determined by watching the cam block and pusher arm inside the right rear side door.

Never use gasoline, gasoline-type lantern fuel, kerosene, charcoal lighter fluid, or similar liquids to start or "freshen up" a fire in this heater. Keep all such liquids well away from the heater while it is in use.

This remarkable design by Harman features the Verti-flow Direct Vent Stoker System.

This unique, high efficiency unit uses only outside air for combustion.

Micro-processor controls provide for an automatic wide range of heat output from 7,000 to 75,000 BTU .

With a big 93 pound hopper capacity, this unit can burn on high approximately 16 hours or extend for over 96 hours on low.

A Room Sensor connected to the micro-processor automatically adjusts the feed rate to compensate for changes in temperature.

The ash pan is large enough to hold the ash from one hopper full of coal at any setting.

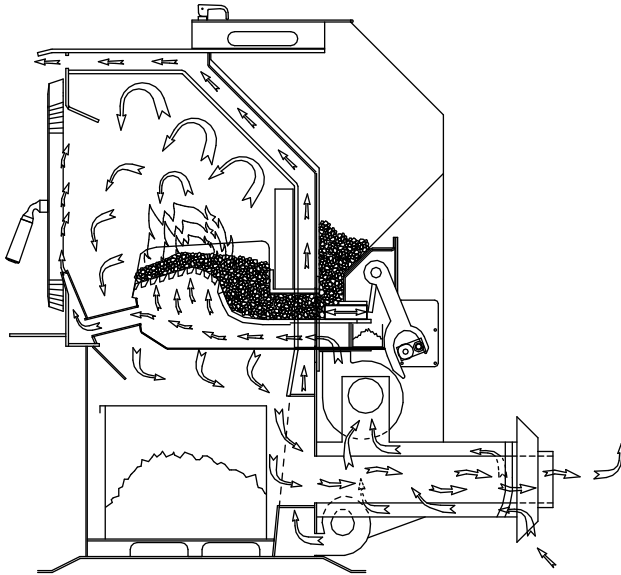

The DVC 500 is the most advanced coal stove ever put into production. However, there are places where it should not be installed. If the end of the flue pipe is:

- 1. Less than 8 feet from an air intake.**
- 2. On the side of the house where a window is left open for sleeping.**
- 3. Less than 5 feet from a door.**
- 4. Less than 7 feet above and 3 feet away from a public walkway.**
- 5. Less than 3 feet above ground level.**
- 6. Between two buildings less than 10 feet apart.**

It is recommended that the end of the flue pipe terminates at least 12 inches away from the side of the building in order to minimize any fly ash build-up.

Mobile home installations should be done in accordance with the Manufactured Home and Safety Standard (HUD), CFR 3280, Part 24.

DAMP COAL SHOULD NOT BE LEFT IN THE HOPPER OF A COLD STOVE.

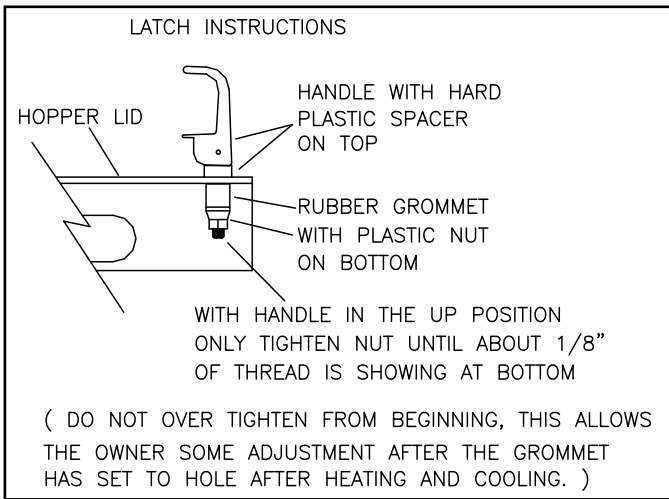

1. Install the hopper latch as shown at left.
2. Install 3 firebricks on the cast iron angle behind the grate as shown.
3. Cement in grates as shown below. This may already be done at the factory.

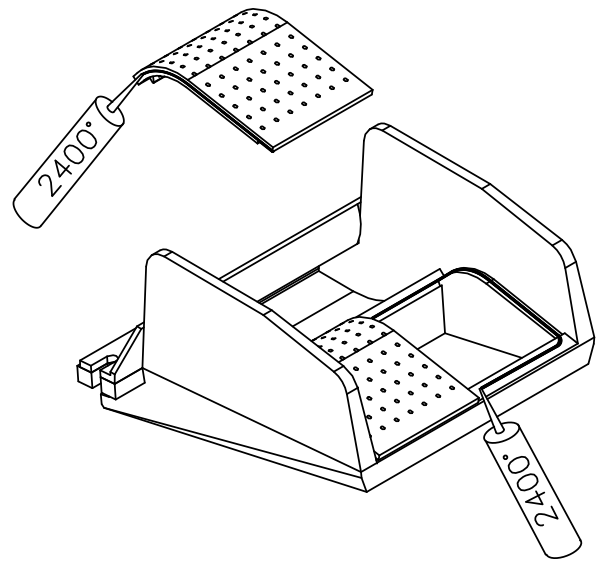
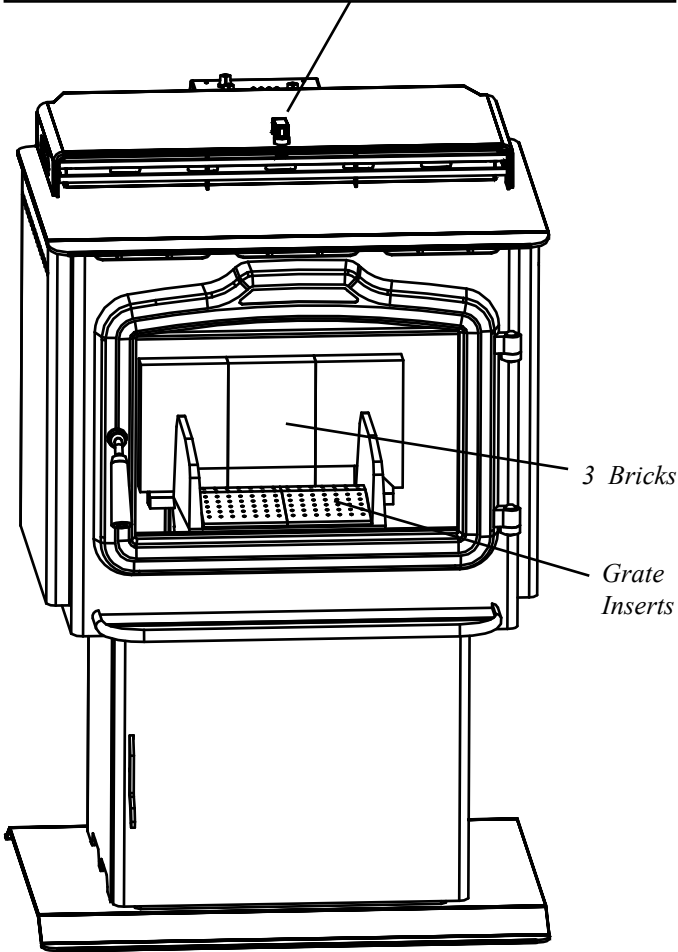

fig. 3

The glass in your Harman stove is a special ceramic glass.

- Do not abuse the glass by striking or slamming the door.
- Never burn the appliance if the door glass is cracked or broken.
- Replace only with Harman supplied glass.

Soot and/or fly-ash may accumulate on the viewing glass, and will occasionally need to be cleaned.

Clean the glass with a soft cloth and mild glass cleaner. Do not spray cleaner on hot glass, and avoid the use of abrasive cleaners.

Glass replacement

Carefully remove all remaining glass and gasket materials prior to replacing the glass.

Lay the door face down on a flat surface. Remove the glass retainers and screws. Apply the gasket material to the face of the new glass. Lay the glass into the door, making sure that the glass is contained within the channels and raised areas of the door itself. Lay the glass retainers into position and install the screws. Tighten each screw evenly to avoid making any stress points.

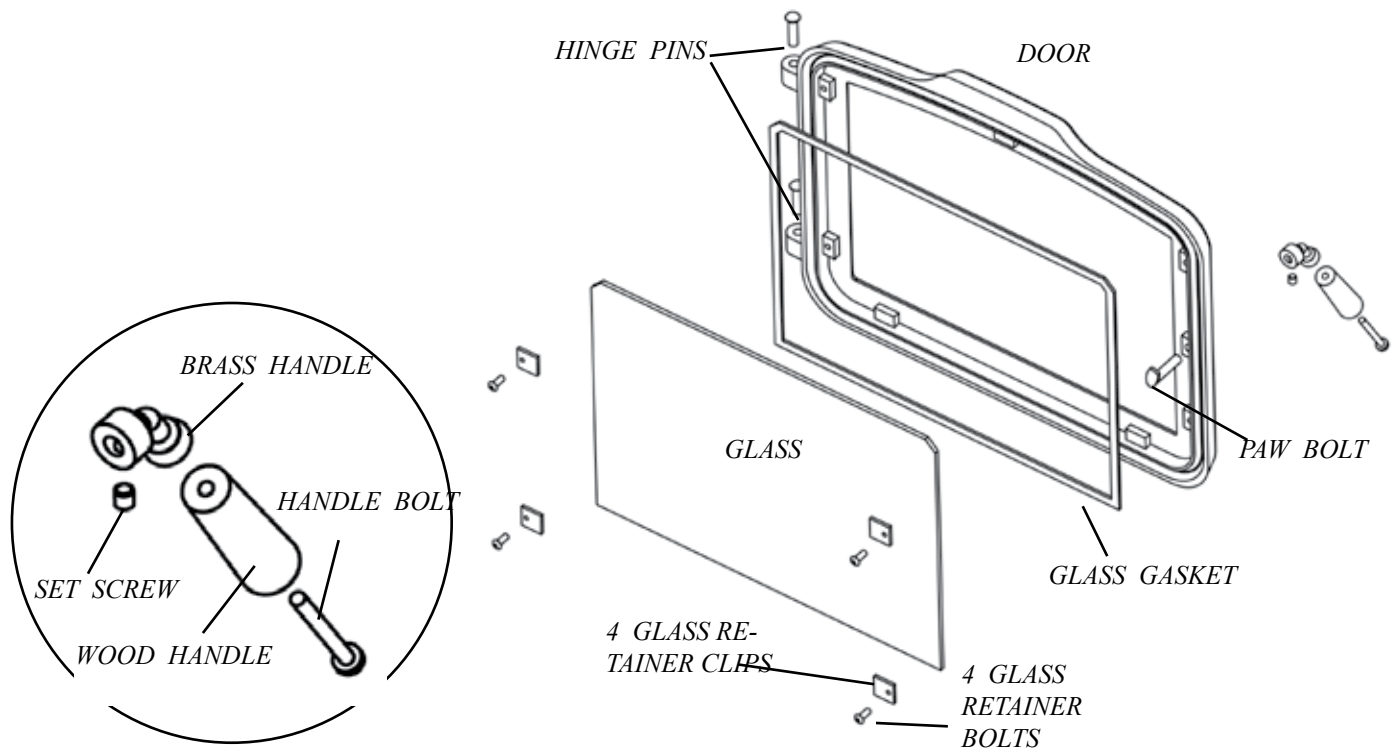

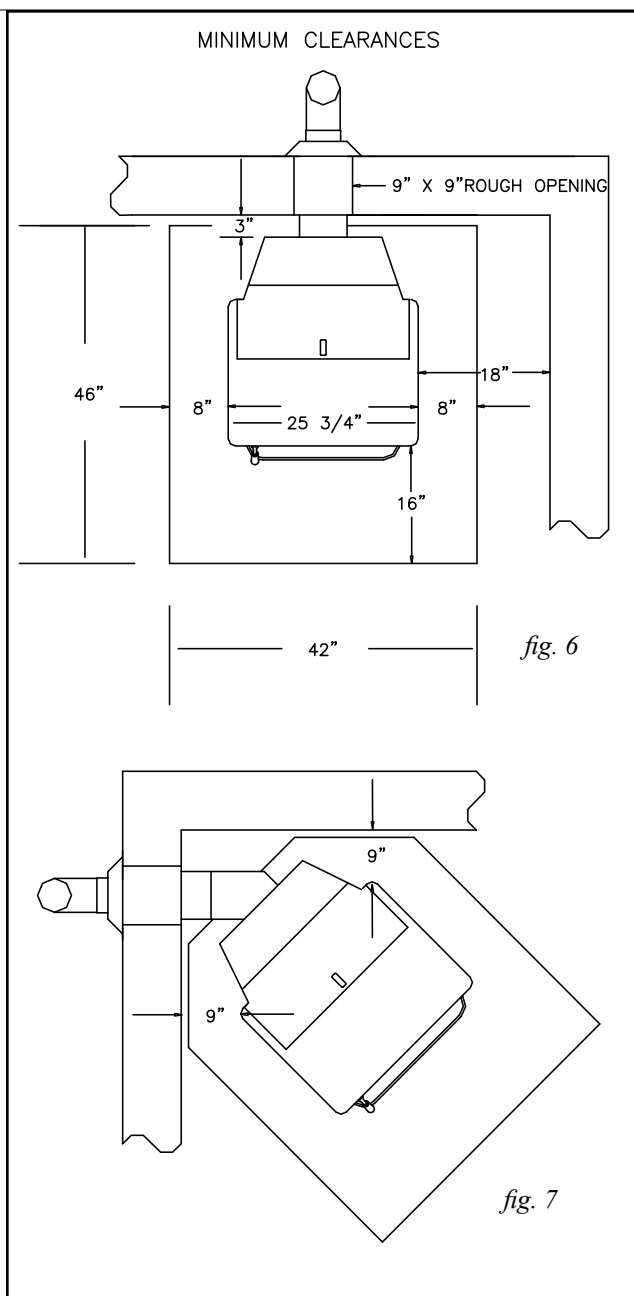

DO NOT INSTALL A FLUE DAMPER IN THE EXHAUST VENTING SYSTEM OF THIS UNIT

DO NOT CONNECT THIS UNIT TO A CHIMNEY FLUE SERVING ANOTHER APPLIANCE.

INSTALL VENT AT CLEARANCES SPECIFIED BY THE MANUFACTURER

Tips On Installation

Before the positioning of the unit can be decided a few questions should be considered?

1. Can the unit be vented properly and installed safely?
2. Will exhaust be vented where fumes can build up or be drawn into lower levels of the structure?
3. Will fumes and fly ash affect the exterior of the structure or surrounding structures?
4. Are there any local regulations governing the use and placement of the unit?
5. Are there any structural reasons why the unit cannot be placed where you want?
6. How close is the electrical outlet?

Follow the guidelines to the left regarding clearances to combustible materials.

Floor Protector

This stove should be placed on a non-combustible floor protector extending 16 inches to the front, 8 inches to the sides, and 1 inch to the rear.

Straight Through Wall

1. When positioning of the unit has been decided, use measurements on Page 10 for cutting the hole through the wall. Don't forget to figure the thickness of the floor protector used.
2. Cut at least a 9" x 9" hole through the wall.
3. Remove the side doors / rear cover assembly (6 black screws, 5/16" socket or straight screwdriver)
4. Place the unit in front of the hole approximately 1/2" closer to the wall than the length of the wall termination. (From outside of wall to back of unit where termination bolts up)
5. Take the wall termination outside and slide it into the hole until it mates to the rear of the unit. Go inside and install the bolts and tighten, making sure the gasket is in place and the flue pipe section is level.
6. Reposition the unit inward until the stainless steel intake section comes against the outside wall surface. NOTE: If the wall is over 8" thick you will need a longer wall termination. The standard termination will provide 3" of wall clearance behind the stove, with a 8" wall. Therefore, with a 5" thick wall, it will provide 6" of clearance behind the stove.

**WARNING:
DO NOT INSTALL IN MOBILE
HOME SLEEPING ROOM**

**CAUTION:
THE STRUCTURAL INTEGRITY OF THE
MOBILE HOME FLOOR, WALL, AND
CEILING/ROOF MUST BE MAINTAINED.**

7. Check the exterior of the termination for best fit and screw to exterior and caulk with high grade exterior caulking.
8. Complete any other exterior flue piping necessary, using 4" pellet venting.
9. Back inside, place the 2 halves of the interior wall trim plate over flue pipe. Using the black pop rivets, fasten together, then slide it against the wall and fasten it to the wall.
10. Replace the side door / rear cover assembly with 6 black screws.
11. Complete the unit assembly and test.

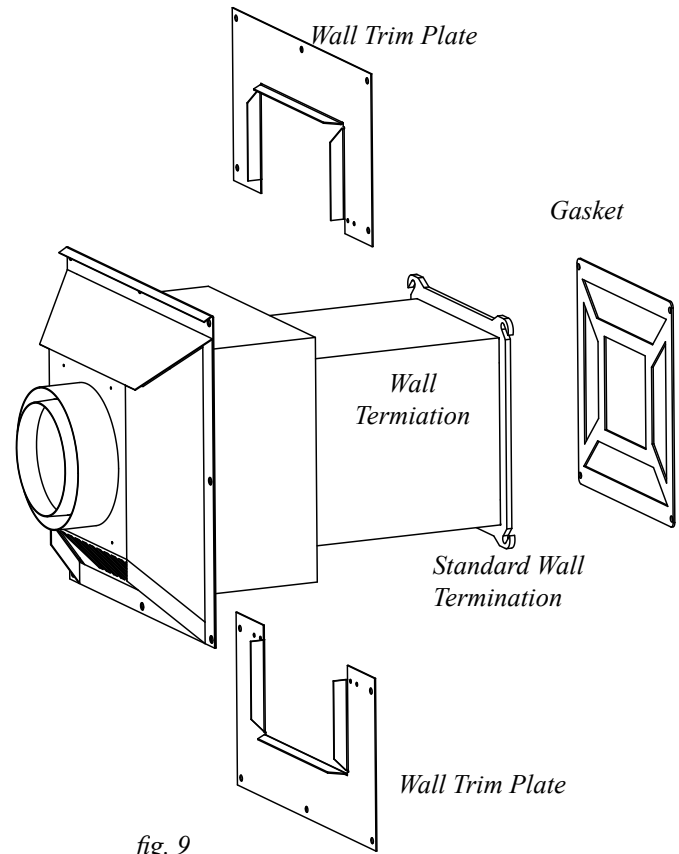
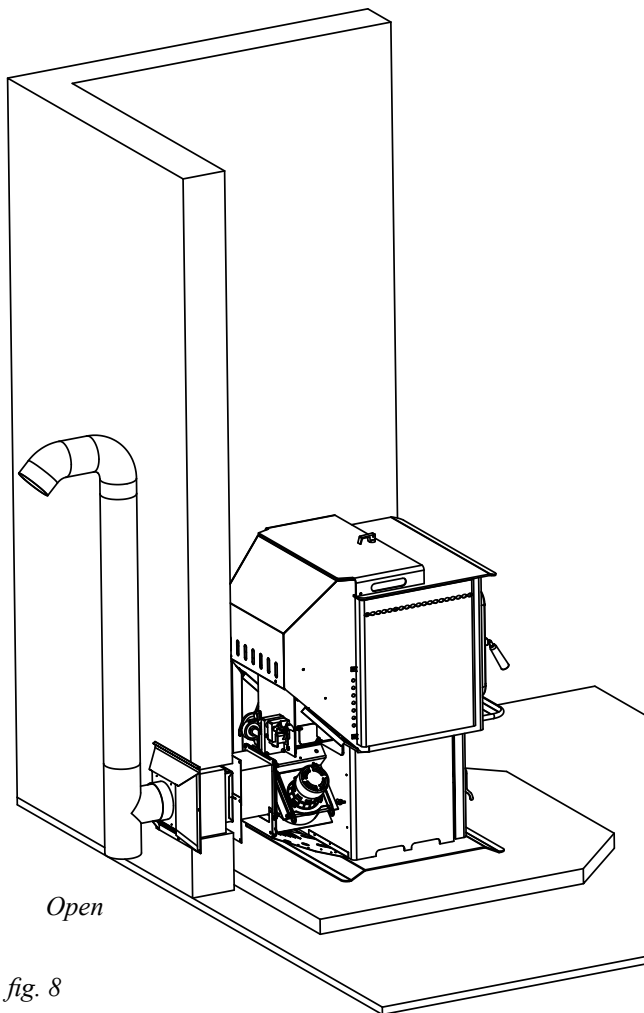

RECOMMENDED INSTALLATION

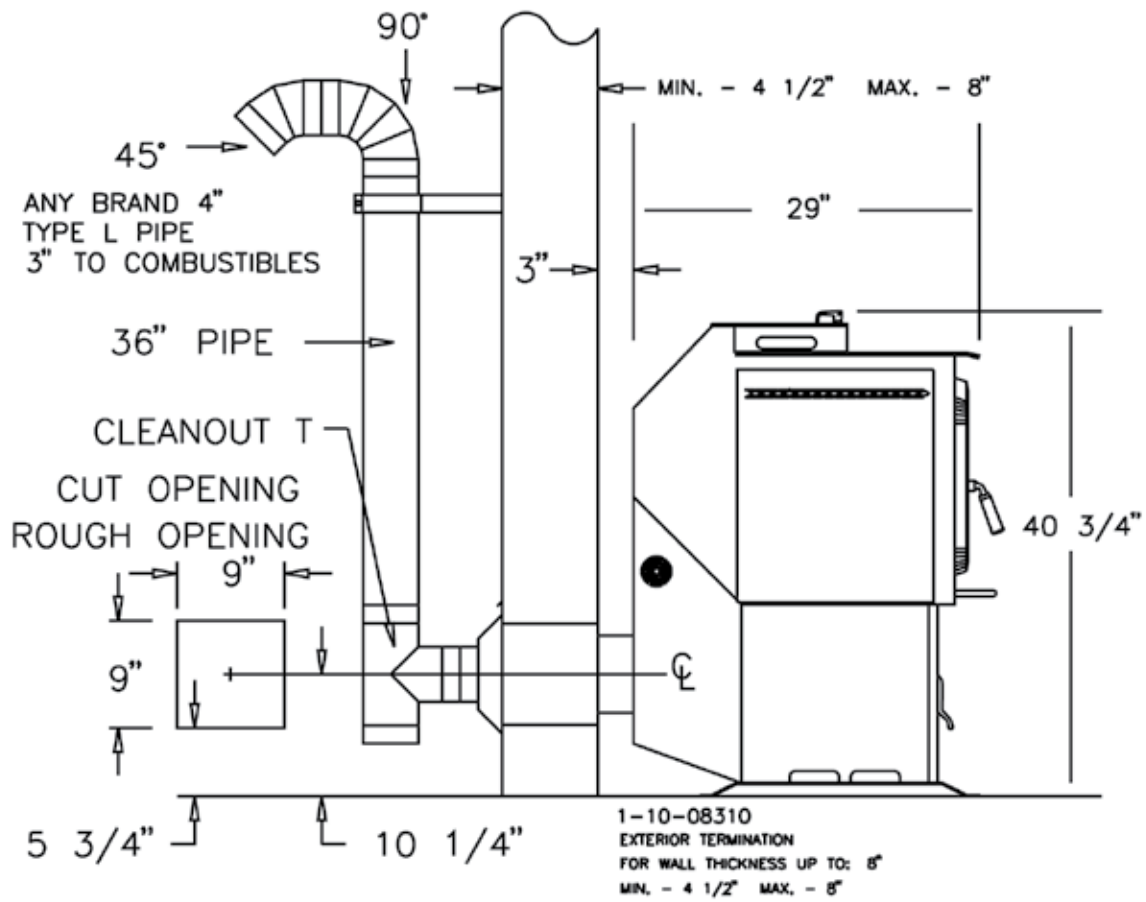

MAINTAINING 3" CLEARANCE TO REAR
AN EXTENDER FRAME CAN BE MOUNTED ON EXTERIOR
EXTRA CARE MUST BE TAKEN TO WEATHERPROOF PROPERLY

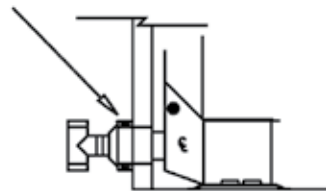

UNIT BOTTOM MUST BE LEVEL WITH PIPE THROUGH THE WALL
PIPE FLANGE MOUNTING TO UNIT FLANGE
MUST BE PARALLEL TO MATE PROPERLY



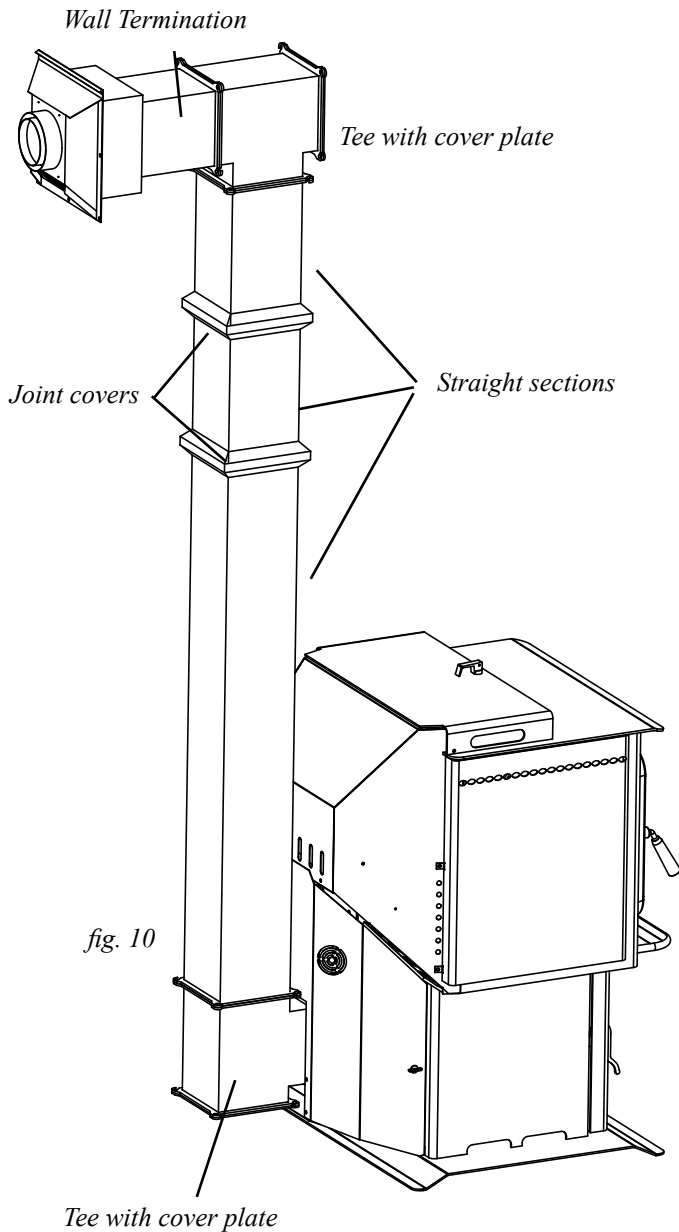

Basement Installation

To install a DVC 500 in a basement you will need additional DVC vent sections. These sections are made with a 316-grade stainless steel liner and a 20 gauge galvaneled outer shell. Each joint is sealed with a gasket and is bolted together with 4 bolts. In order to maintain the best seal, there are no adjustable sections. There are straight, 45 degree, and Tee fittings. Refer to Page 14 for all of the sections available.

Never use venting other than Harman DVC venting inside the building. It is the only vent certified for this appliance.

Refer to page 12 & 14 to calculate which sections will be needed for your installation.

Corner Installation

A corner installation requires a 45 degree section in addition to the standard wall termination.

In order to cut a hole in the wall that will allow the stove to be placed an equal distance to each wall, refer to Page 13.

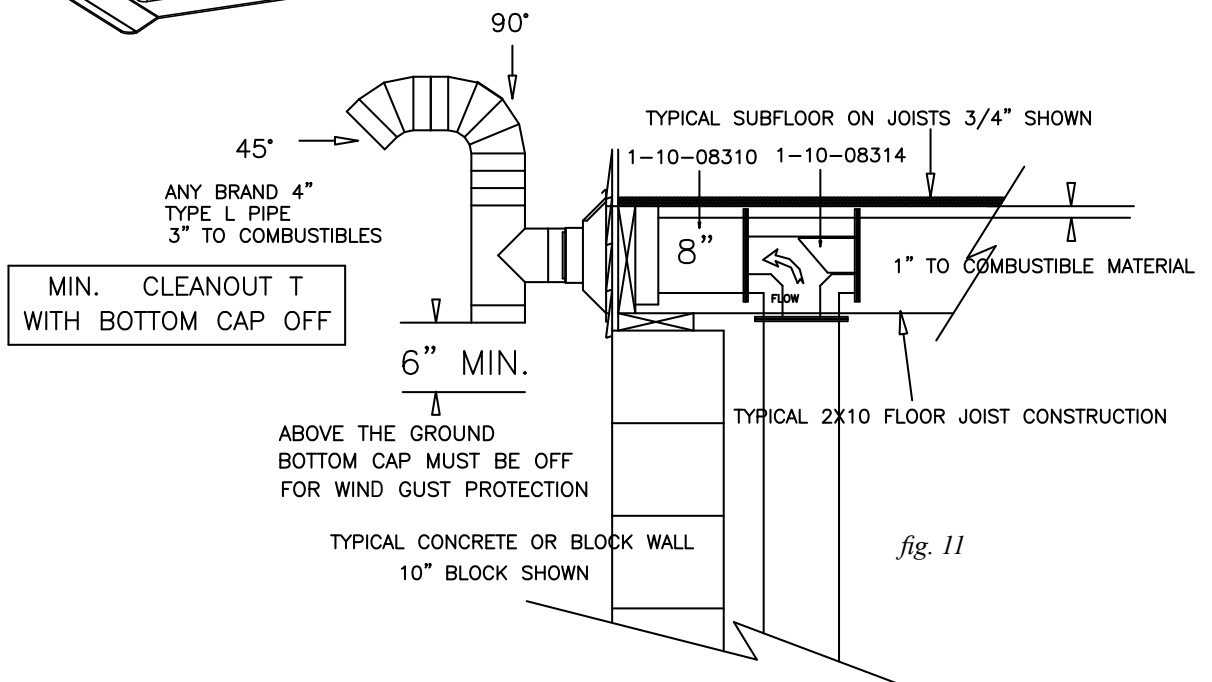

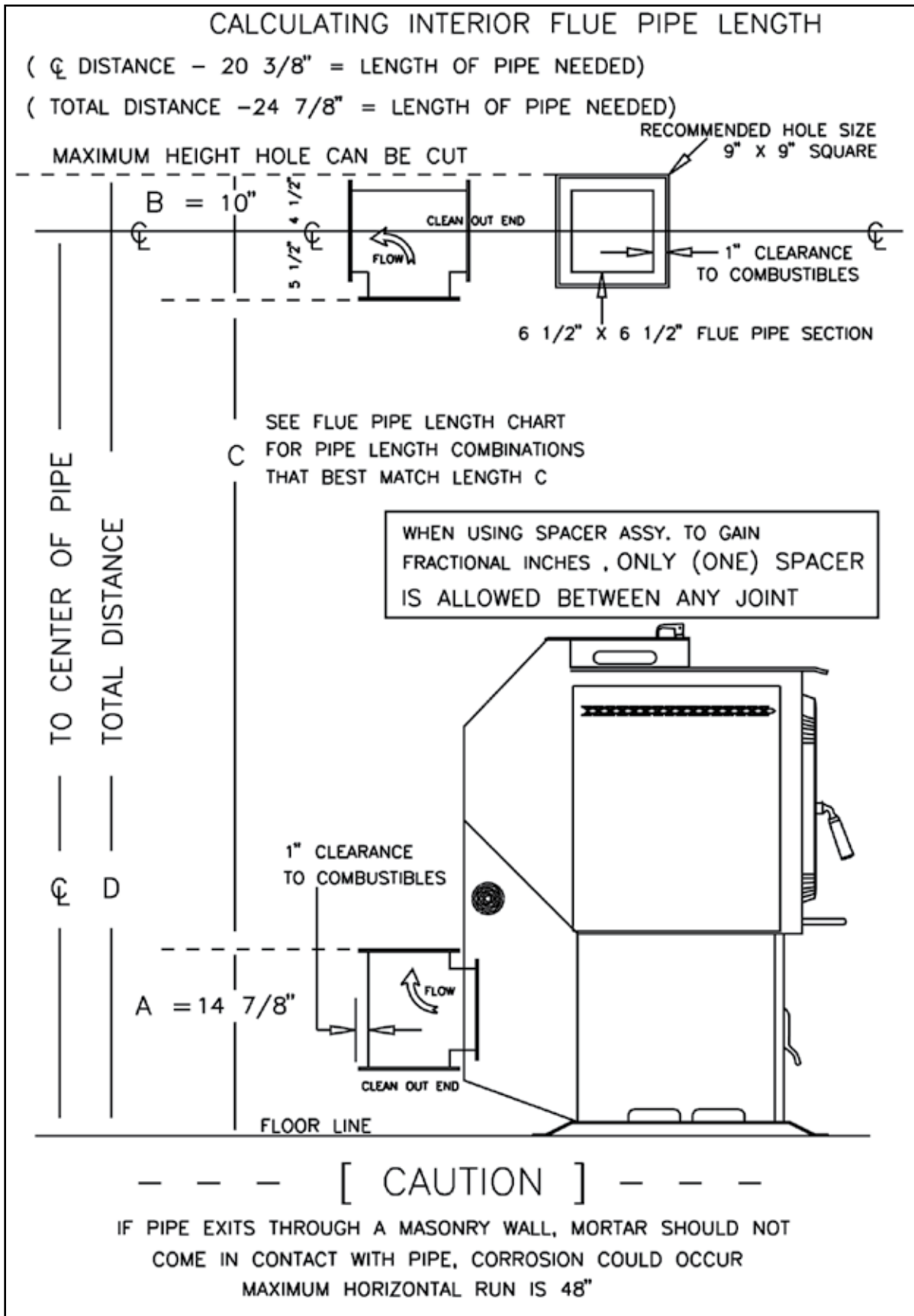

CORNER INSTALLATION

CALCULATING CENTER LINE OF PIPE FROM CORNER

WALL THICKNESS	-	CENTER LINE
4 1/2"	-	14 1/4"
4 3/4"	-	14"
5"	-	13 3/4"
5 1/4"	-	13 1/2"
5 1/2"	-	13 1/4"
5 3/4"	-	13"
6"	-	12 3/4"
6 1/4"	-	12 1/2"
6 1/2"	-	12 1/4"
6 3/4"	-	12"
7"	-	11 3/4"
7 1/4"	-	11 1/2"
7 1/2"	-	11 1/4"
7 3/4"	-	11"
8"	-	10 3/4"
8 1/4"	-	14 1/2"
8 1/2"	-	14 1/4"
8 3/4"	-	14"
9"	-	13 3/4"
9 1/4"	-	13 1/2"
9 1/2"	-	13 1/4"
9 3/4"	-	13"
10"	-	12 3/4"
10 1/4"	-	12 1/2"
10 1/2"	-	12 1/4"
10 3/4"	-	12"
11"	-	11 3/4"
11 1/4"	-	11 1/2"
11 1/2"	-	11 1/4"
11 3/4"	-	11"
12"	-	10 3/4"
12 1/4"	-	14 1/2"
12 1/2"	-	14 1/4"
12 3/4"	-	14"
13"	-	13 3/4"
13 1/4"	-	13 1/2"
13 1/2"	-	13 1/4"
13 3/4"	-	13"
14"	-	12 3/4"
14 1/4"	-	12 1/2"
14 1/2"	-	12 1/4"
14 3/4"	-	12"
15"	-	11 3/4"
15 1/4"	-	11 1/2"
15 1/2"	-	11 1/4"
15 3/4"	-	11"
16"	-	10 3/4"

EXTERIOR TERMINATION FOR WALL THICKNESS UP TO: 8"

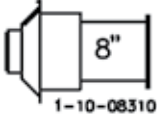

1-10-08310

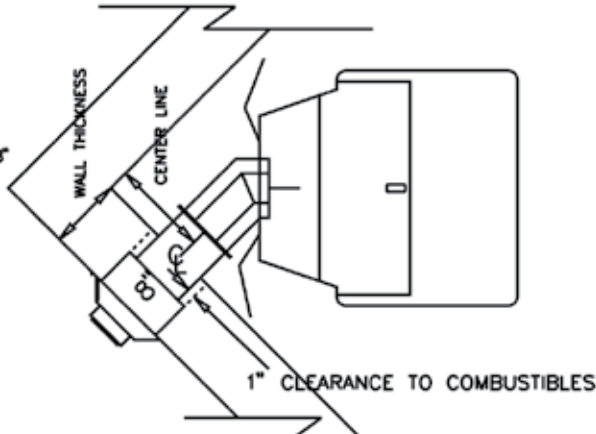

EXTERIOR TERMINATION FOR WALL THICKNESS UP TO: 12"

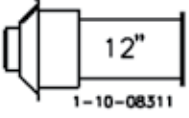

1-10-08311

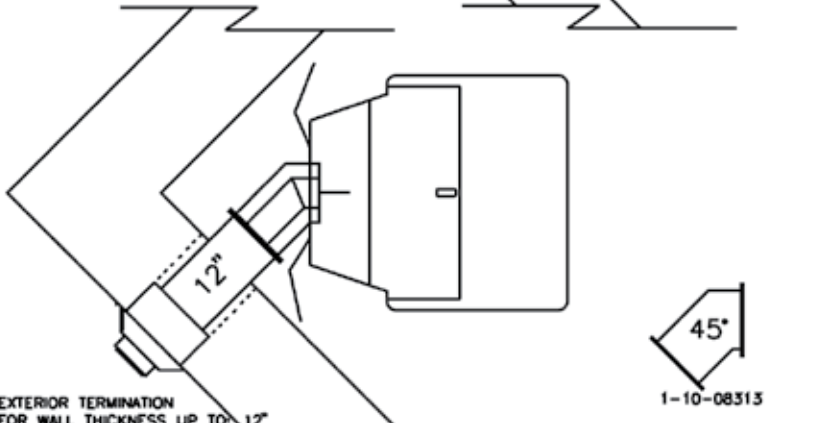

EXTERIOR TERMINATION FOR WALL THICKNESS UP TO: 16"

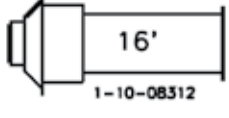

1-10-08312

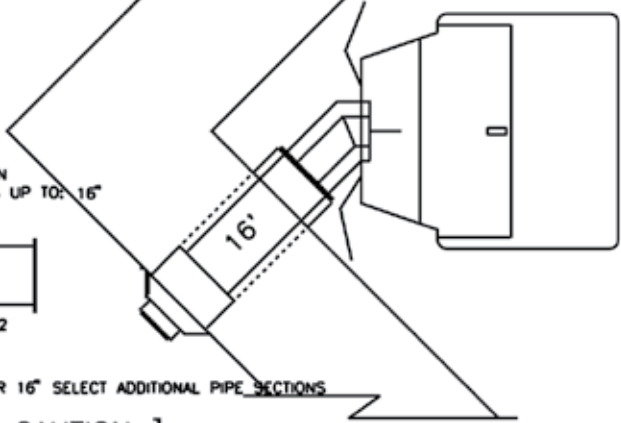

FOR WALL THICKNESSES OVER 16" SELECT ADDITIONAL PIPE SECTIONS

--- [CAUTION] ---

IF PIPE EXITS THROUGH A MASONRY WALL, MORTAR SHOULD NOT COME IN CONTACT WITH PIPE, CORROSION COULD OCCUR

MAXIMUM HORIZONTAL RUN IS 48"

Harman Direct Vent Coal Flue Pipe Venting System

1" Clearance to Combustibles

Exterior Termination for wall thickness up to 8 inches

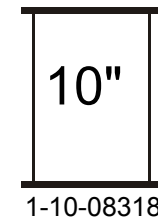
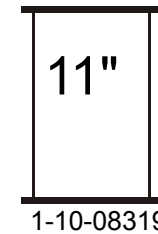
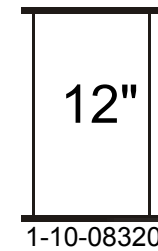
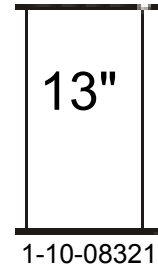
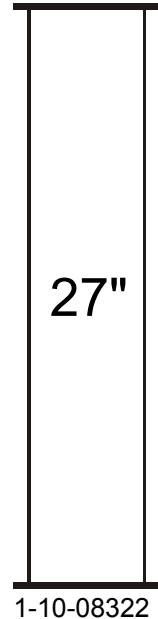
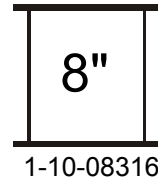
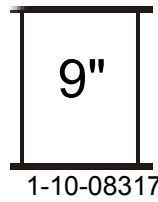
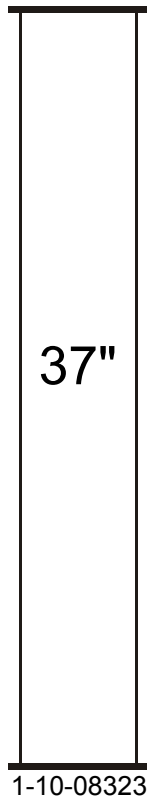
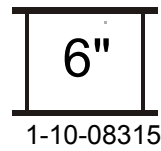
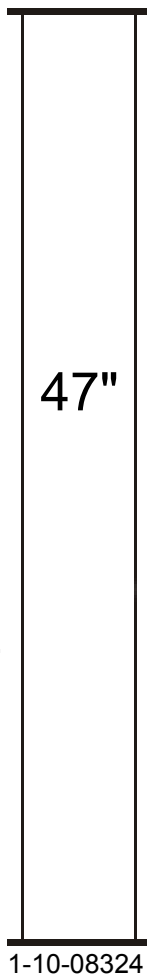
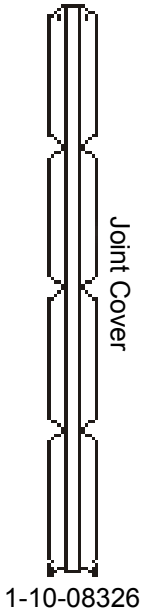
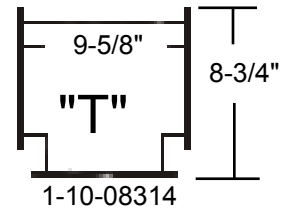
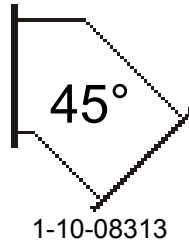
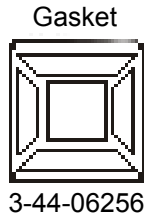
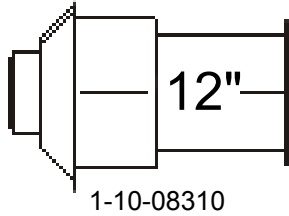

Exterior Termination for wall thickness up to 16 inches

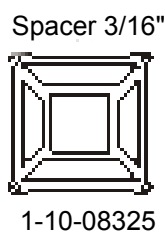
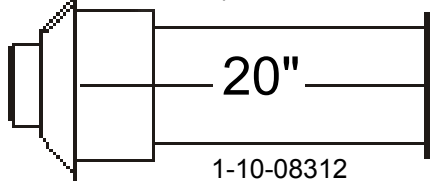

Exterior Termination for wall thickness up to 12 inches

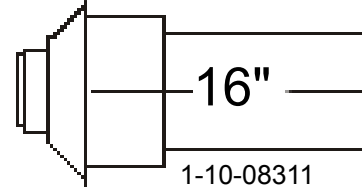

Maximum Horizontal Run is 48 Inches - (4 ft.)

ESP CONTROL

Power Light

Indicates power is "on" to the control.

Status Light

Will be lit in either Stove or Room Temp Mode when pointer is not within "off" position band except after normal shut down. Blinks to indicate errors listed below.

Indicates power to Distribution Blower

Indicates power to Combustion Blower

Indicates power to the Feed Motor.

Indicates power to the Draft Motor.

Temp Dial

Allows you to adjust the room temperature in Room Temp Mode using the outer scale marked in degrees Fahrenheit. It also allows you to adjust the stove temperature while in Stove Temp Mode using the inner scale marked from 1 to 7.

DDM Port

Allows service technician to attach diagnostic meter when troubleshooting or verifying proper operation.

Mode Selector

Allows you to choose between Room Temp Mode, Stove Temp Mode, or OFF. Also allows you to vary the Distribution Blower speed by turning the knob to the "high" or "low" side of each mode.

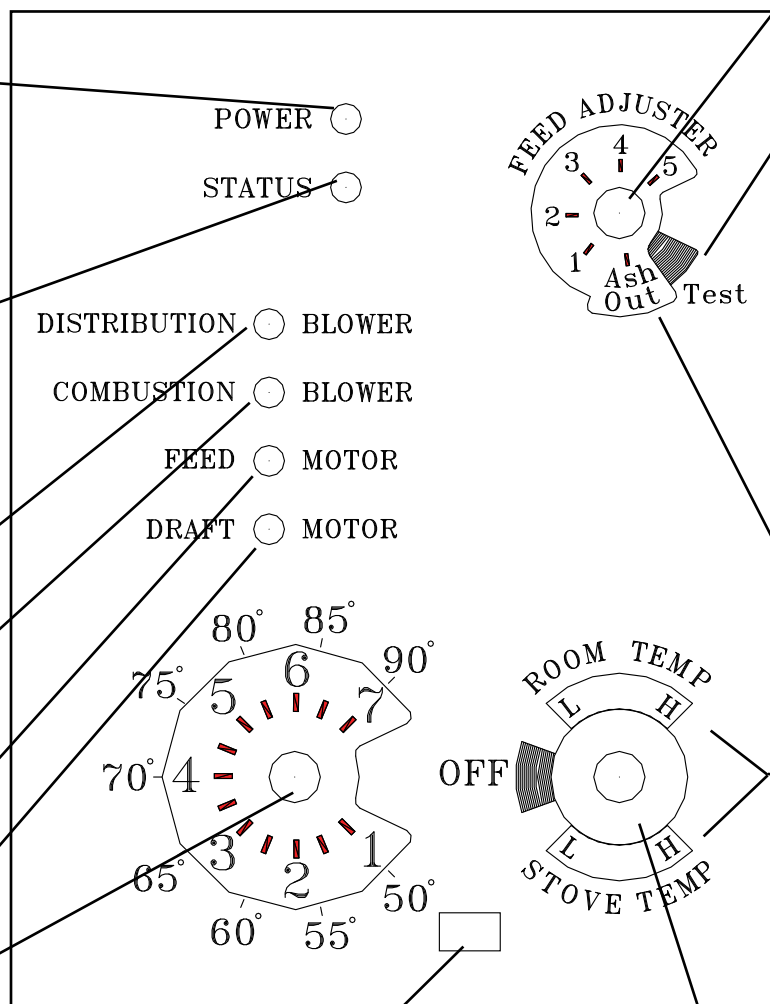

Feed Adjuster

Sets the maximum feed rate, 1 to 5

Test

Runs all motors at full speed for two minutes to check operation. After two minutes the feeder stops and the distribution blower alternates from high to low every four seconds to remind you that you are still in "Test Mode".

Ash Removal position

See page 19

Distribution Blower speed adjustment range.

fig. 12

Status Light Error Messages:

2 Blinks: Indicates that there is insufficient negative pressure in the firebox. This begins a shut-down process described in more detail on Page 31.

The most common cause of the 2 blink status is leaving the ash door open without turning the Feed Adjuster to "Ash Out". For other causes of a 2 blink status see Page 32.

This requires a Manual Reset*.

3 Blinks: Indicates that the ESP (Exhaust Sensing Probe) has gone out of range a specified number of times. If the stove seems to be performing normally, perform a Manual Reset*.

4 Blinks: Can occur only in Room Temp Mode and indicates Room Sensing Probe has failed or is not installed. If a Room Sensing Probe is then installed, the status light will automatically reset.

5 Blinks: Indicates a lack of communication between the circuit board and the TCP (Temperature Control Probe). This requires a manual reset*.

* **Manual Reset:** Disconnect power cord for a few seconds and reconnect. If error still occurs call your Dealer.

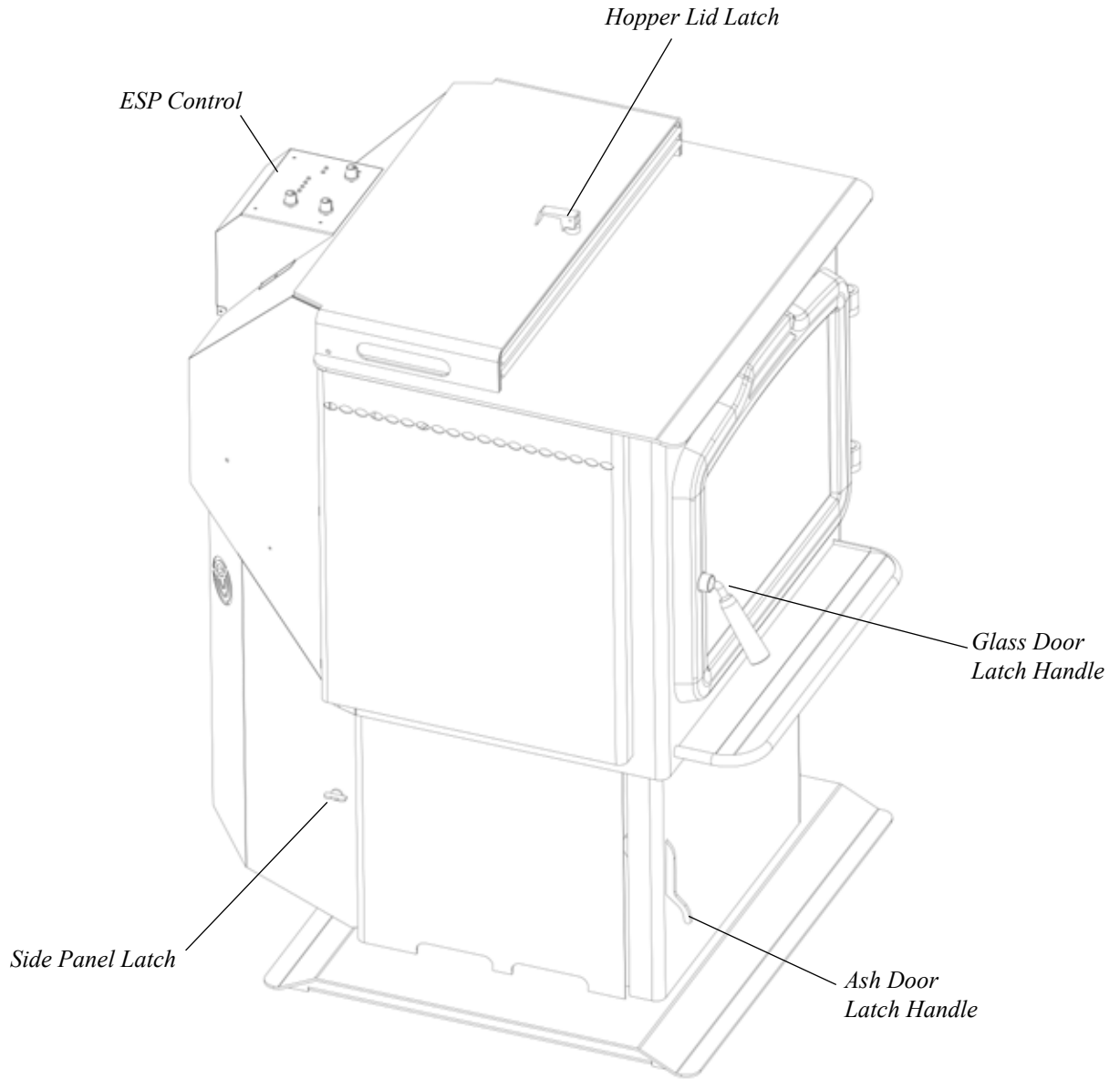

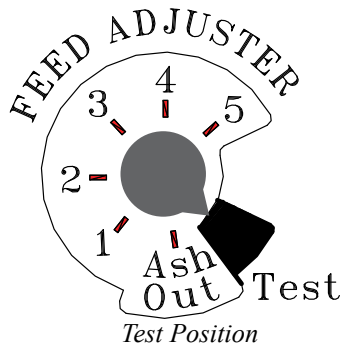

fig. 13

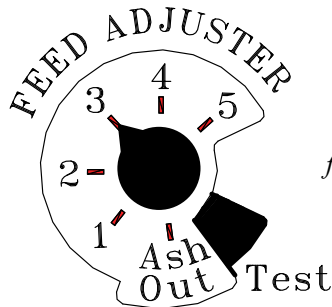

fig. 14

#3 Feed Adjustment setting

Testing Operation:

Turn the Feed Adjuster to "Test" mode, (fig. 13.) This will cause all motors to run 100% for 2 minutes. The lights on the control panel will be lit for each motor. If you leave it on "test" the blowers will cycle as an audible reminder.

Starting Fire:

1. Fill the hopper with dry coal. **NOTE: Remove all coal from hopper ledge. (fig 17)**
2. Fill burn-grate area from firebrick to front of grate with about one inch of (DRY) coal.
3. Plug into 120 volt AC outlet and turn control to "OFF". Turning to "OFF" and then back to the desired mode resets the control.
4. Turn Feed Adjuster to the # 3 position, fig. 14.
5. Make a valley in the coal at the top of the burn grate. Fill valley with fire starting material (coal starter, crushed charcoal, wood pellets).
6. Turn Mode Selector to Room Temp or Stove Temp as desired.
7. Turn the Temp Dial to the desired setting.
8. Light the fire and make sure that all doors and the hopper lid are closed. As the ESP senses the correct temperature, the Feed Motor will start.

Shutdown Procedure:

To kill the fire or stop burning the stove, turn the Mode Selector knob to the "OFF" position. This will stop the feeder and the fire will burn out. When the stove cools to about 95 degrees Fahrenheit, all motors will stop. The unit can then be unplugged. **NOTE: It is always best to let the stove run out of coal to shut it down rather than use the "OFF" position. This is because there is no moisture left in the hopper from the coal. Always run the stove out of coal to shut it down when the heating season is over or if the stove will not be used for several days.**

Restarting Fire After Shutdown:

All ash and partially burned coal must be cleaned out from behind grates down under firebrick until fresh coal is seen. Follow "Starting Fire" procedure above.

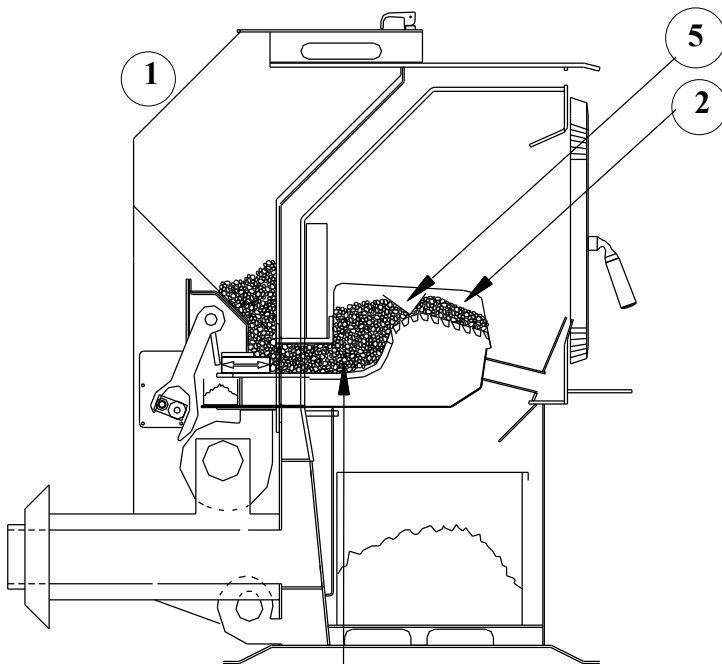

fig. 15

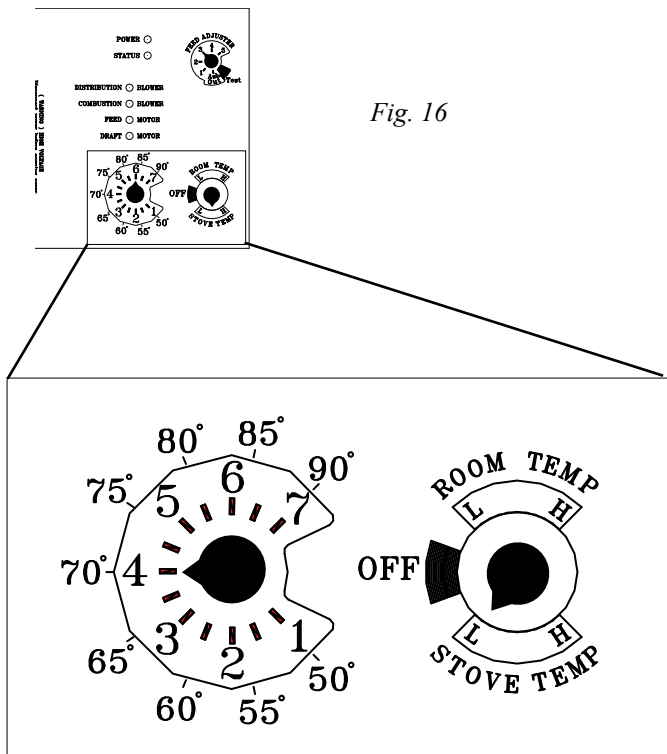
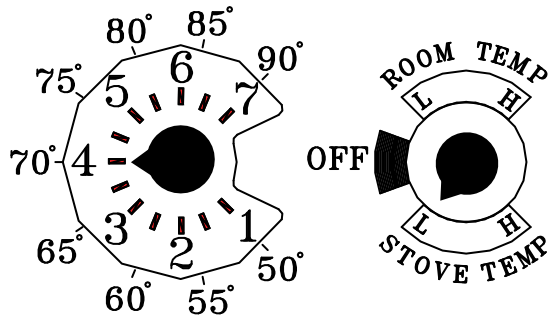
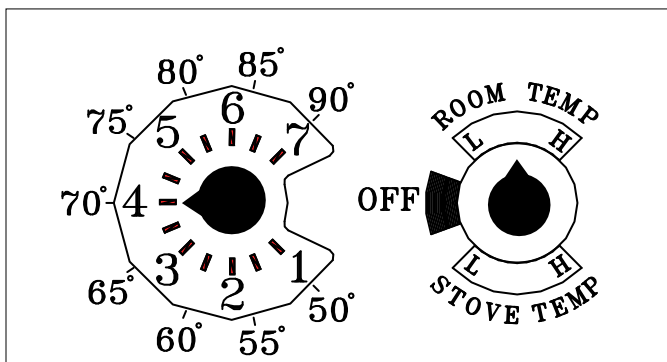

Fig. 16



This setting will produce medium heat with the Distribution Blower on "low".



This setting will produce a room temperature of 70 degrees with the Distribution Blower at "medium" speed.

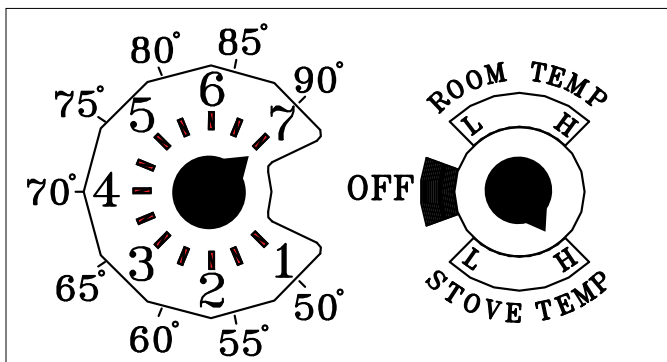

This setting will produce continuous maximum heat output with the Distribution Blower at full speed.

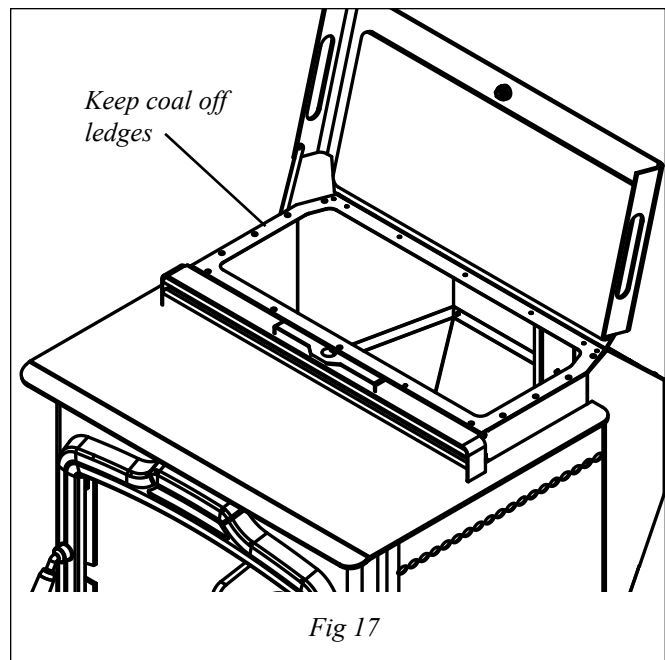

Fig 17

When to use "Stove Temp Mode"

In "Stove Temp Mode" the control will regulate the fire to match a constant exhaust temperature, based on the #1 thru 7 settings on the inner portion of the temp dial. Heat output and fuel consumption will remain constant. This makes it possible to tell how long a hopper full of coal will last. The distribution blower speed can be varied according to the position of the mode selector, between "low" and "high", fig. 16.

When to use "Room Temp Mode"

In "Room Temp Mode" heat output is controlled automatically by use of the Room Sensing Probe. When the Room Sensing Probe calls for heat, the stove will increase output. When the Room Sensing Probe is getting close to the set temperature, the stove will begin to level off output and keep the fire burning at just the right temperature to maintain that setting. If the temperature in the room exceeds the set point, the stove will idle on a low burn until more heat is needed.

High output is determined by the Feed Rate. The maximum Feed Rate should be set for 1 1/2" to 2" of ash in front of the fire.

In "Room Temp Mode" fuel consumption is sacrificed for exact room temperature. Therefore, as it gets colder, more coal will be burned automatically.

The distribution blower speed can be varied according to the position of the mode selector.

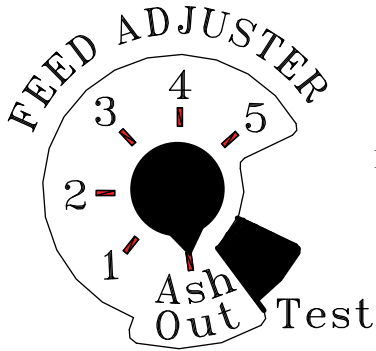

Fig. 18

Ash Out Position

If the feed adjuster is left in the "Ash Out" position the fire will burn out.

WARNING

OPENING THE VIEWING DOOR OR ASH DOOR WITHOUT TURNING THE FEED ADJUSTER TO THE "ASH OUT" POSITION MAY CAUSE COMBUSTION GASES AND FLY ASH TO ESCAPE.

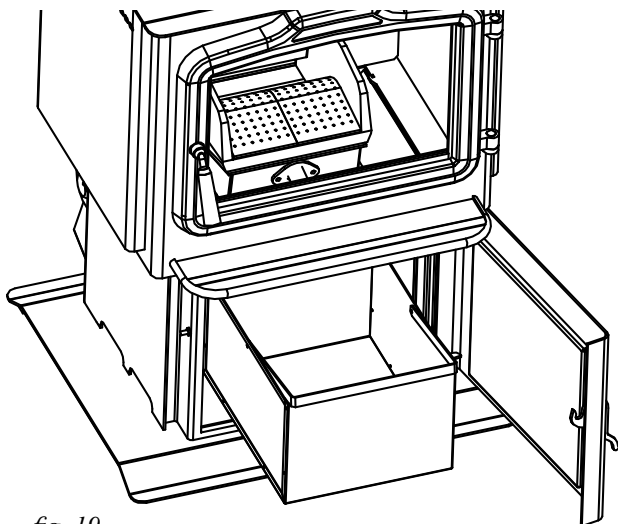

fig. 19

Ash Removal

With each hopper of coal that is burned, approximately one ashpan full of ashes must be removed. (fig. 19) It may take from one to four days for the ash pan to get full, depending on the burn rate.

Failure to remove the ashes will result in a blocked grate and the fire will not burn properly. Remember, the ashpan will be hot, so always wear protective gloves.

Ash Removal Setting:

The "Ash Out" position on the feed adjuster knob is for ash removal (fig. 18). This position stops the Combustion Blower, the Feeder Motor, and slows the Distribution Blower so the doors can be opened. This is to limit exhaust fumes from leaving the unit.

Don't forget to turn knob back to previous feed number setting after completion of ash removal.

Removing Ash While Unit Is Burning:

CAUTION: ASH PAN HANDLE WILL BE HOT, WEAR GLOVES.

Make note of the position of the Feed Adjuster knob so it can be returned to the same position when you are finished removing the ashes.

Turn the Feed Adjuster knob to "Ash Out", this is the ash removal setting, Fig 18. This setting turns off the Combustion Blower and Feeder Motor but does not turn off Draft Motor. Now the ash door can be opened with minimal exhaust leakage. If ash removal takes more than 4 minutes, the Distribution Blower will start to cycle up and down to indicate the Feed Adjuster knob was left in the "Ash Out" position. This is not a problem if you remember to return the Feed Adjuster to its previous setting when completed. ***If left in the "Ash Out" position, the fire will burn out.***

Ashes should be placed in a metal container with a tight fitting lid. The closed container of ashes should be placed on a noncombustible floor or on the ground, well away from all combustible materials, pending final disposal. If ashes are disposed of by burial in soil or otherwise locally dispersed, they should be retained in the closed container until all cinders have thoroughly cooled.

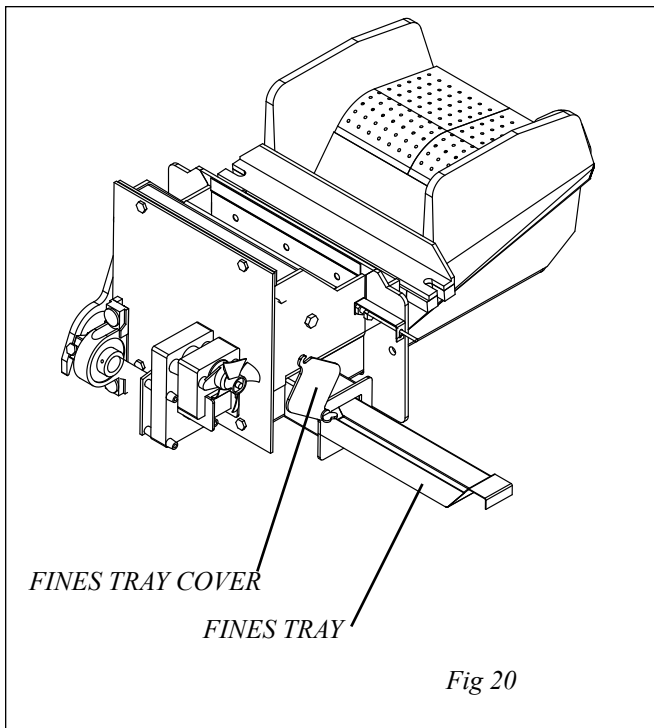

Empty Fines Tray

The small Fines Tray in the side of the stoker should be removed and emptied

To remove the Fines Tray, first open the door on the left rear of the stove. Next, loosen the thumb screws holding the Fines Tray Cover, fig# 20. Next, turn the cover 90 degrees and slide out the Tray as shown. If the Tray has over- flowed, use a vacuum cleaner to reach into the opening and remove the excess material.

Cleaning Glass While Unit Is Burning:

Caution: The glass and door frame will be hot, gloves must be worn.

Turn the temperature control to lowest setting and allow the stove to cool down. Have all cleaning supplies ready and close by. Take note at which # the Feed Adjuster is set, fig 14. Turn Feed Adjuster knob to "Ash Out". (This is the ash removal setting.) This setting turns "off" the Combustion Blower and Feeder Motor but does not turn "off" the Draft Motor. Now the viewing door can be opened with minimal exhaust leakage. Use a safety razor in handle and scrape the inside of the glass with the blade almost flat to the surface, Fig 21. If further cleaning is necessary, the window can now be cleaned with liquid cleaner and a non synthetic cloth. **CAUTION: Do not spray cleaner directly on Hot Glass.** If the cleaning takes more than 4 minutes, the Distribution Blower will start to cycle up and down to indicate the Feed Adjuster knob was left in the "Ash Out" (ash removal setting). This is not a problem, just remember to return the Feed Adjuster to its previous setting when completed.

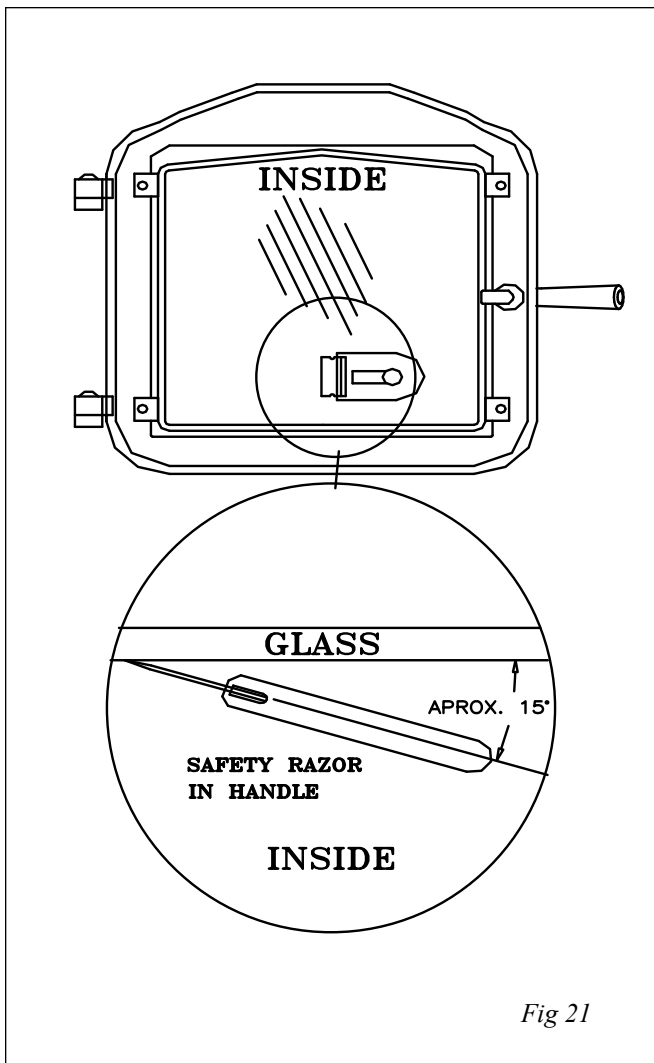

Soot and Fly Ash

The products of combustion will contain small particles of fly ash. The fly ash will collect in the exhaust venting system and restrict the flow of the flue gases. Incomplete combustion, such as occurs during startup, shutdown, or incorrect operation of the room heater, will lead to some soot formation which will collect in the exhaust venting system. The exhaust venting system should be inspected at least once every year to determine if cleaning is necessary.

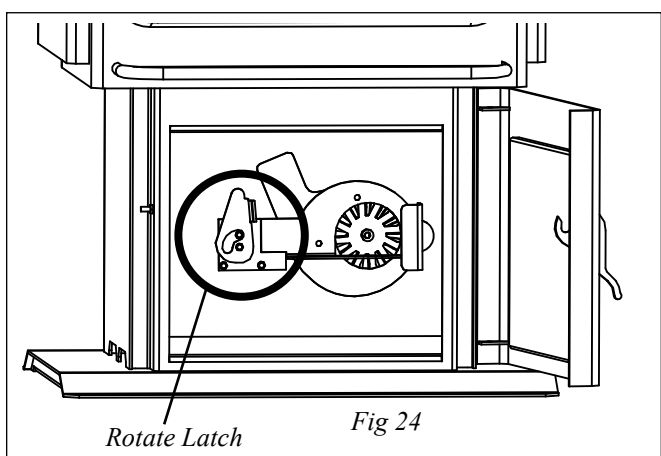
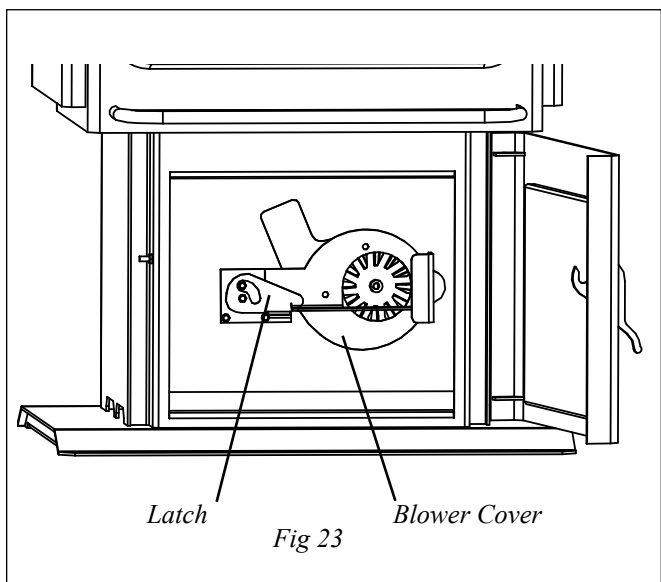
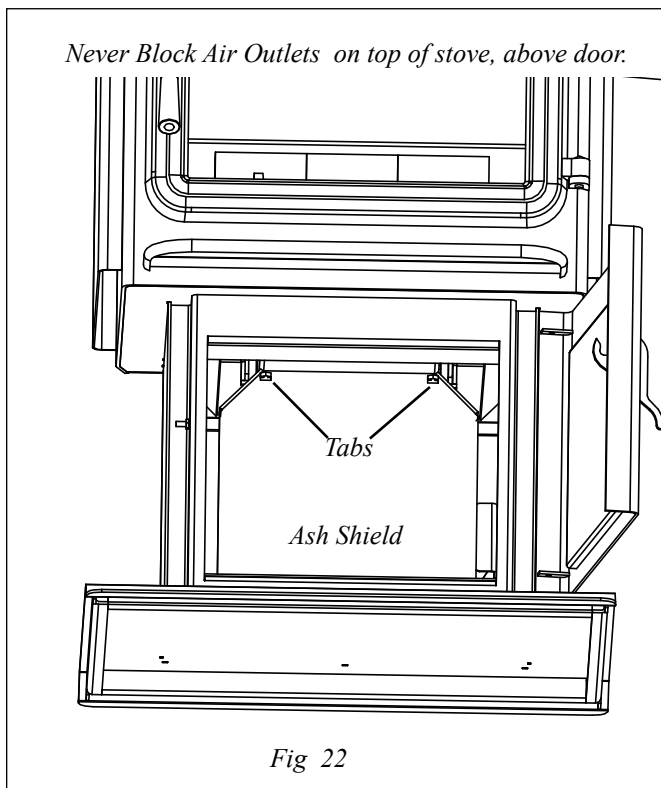

A 3-month cleaning will give you a base line as to how often your DVC500 needs to be cleaned. Cleaning intervals will differ in each installation because of the ash and moisture content of the coal and the amount of coal burned.

NOTE: Unit should be off & cooled down enough to perform these maintenance items:

1. Remove Ash Pan then remove ash shield behind Ash Pan, fig.22. Lift the shield up and forward in order to remove it from the stove. This will expose the Blower Cover and Latch, fig.23.
2. Rotate the Latch counterclockwise to the vertical position as shown in fig. 24.
3. Remove the Blower Cover by tilting the left side slightly forward. Next, slide the Cover left and out of the slot that holds the right side in place. The Cover can now be removed to expose the Draft Blower Wheel and Exhaust Outlet, fig. 25.
4. The blower wheel, blower housing, and exhaust outlet can now be cleaned with a brush and vacuum cleaner. **NOTE:** The ESP probe is located at the rear of the exhaust outlet shown in fig 28. **Be careful not to damage the probe when cleaning.**
5. Open the Fines Cover on the bottom of the feeder under the grates and clean, see fig.26. **ATTENTION: MAKE SURE COVER IS CLOSED AND TIGHTENED BEFORE RELIGHTING UNIT. UNIT WILL NOT OPERATE PROPERLY WITH CLEAN OUT COVER LEAKAGE.**
6. Check the flue pipe for excess buildup of fly ash and clean if necessary.
7. Clean the glass thoroughly, use a safety razor to scrape the sulfur buildup from the surface of glass. Then clean with standard window cleaning fluid, fig.21.
8. Inspect all gaskets for damage and turn the control to "test", for motor test before relighting a fire.

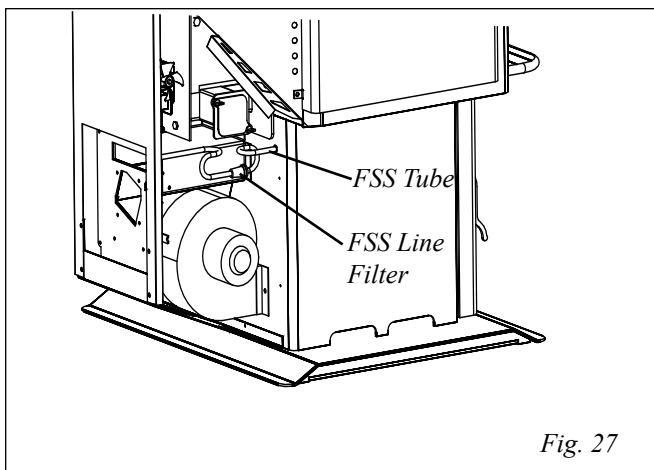
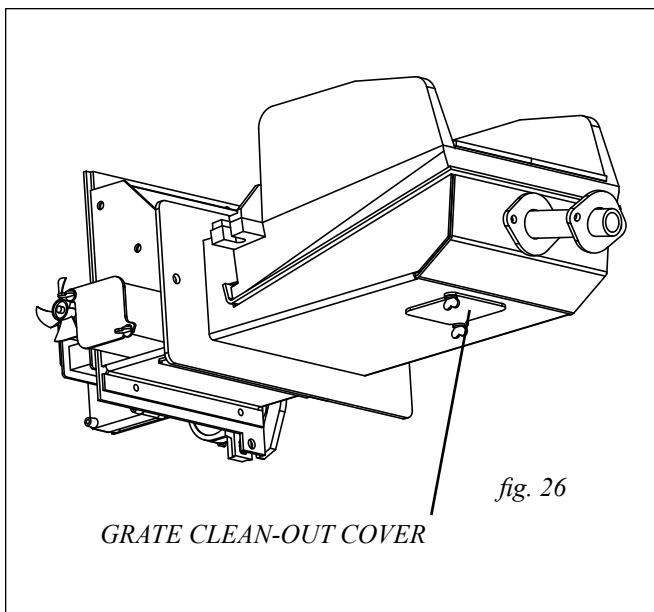
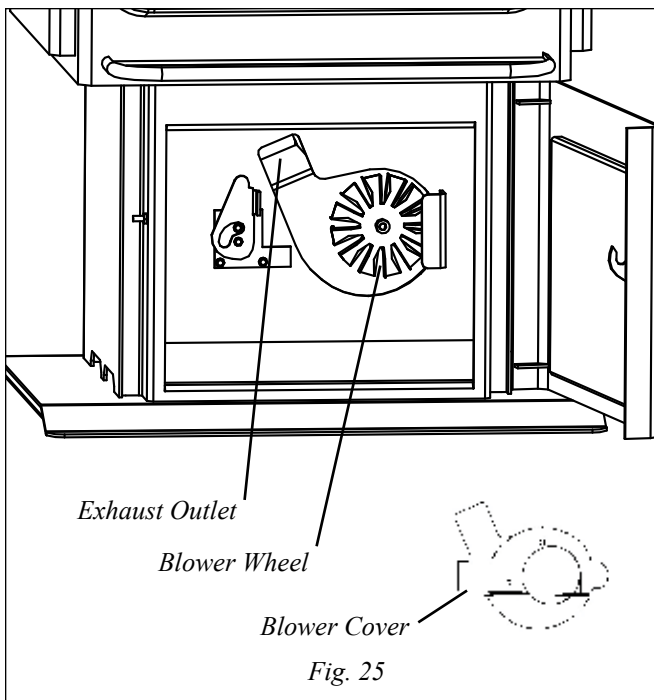

The End Of Season Shut Down List.

1. Allow the stove to run out of coal in order to extinguish the fire. This saves having to remove the coal from the hopper manually and most importantly, drives the moisture out of the stove that may be present in the coal.
2. Perform all the steps of the 3 month maintenance list.
3. Clean the glass as shown in fig.21.
4. Empty the fines tray and inspect the area for rust and corrosion
5. Make sure the hopper is empty. Wet or damp coal in the hopper will promote rust.
6. Remove the FSS Tube from the rear of the firebox (fig.27) and clean the brass fitting going into the firebox with a pipe cleaner. Reconnect tube.
7. The FSS line filter can be changed annually to insure proper flow, however, it may only be necessary if the filter is discolored.
8. Remember to cover the flue pipe over the summer to block out rodents and birds. Place a note inside the unit to remind yourself or others not to forget to uncover the flue pipe before lighting a fire.

Prevent Rust

Summertime moisture and high humidity are your stove's enemy. A clean stove will have less fly ash and fines to absorb moisture and cause rust and corrosion. Allowing wet coal to remain in the hopper of a cold stove will promote the formation of rust and corrosion. Some owners choose to spray a light coating of oil on all internal workings and the firebox as a rust inhibitor.

Annual Service

It is recommended that your DVC500 is serviced annually by your trained Harman dealer. The best time for this service is during a non-use period. You may choose to combine this service with the end of season maintenance.

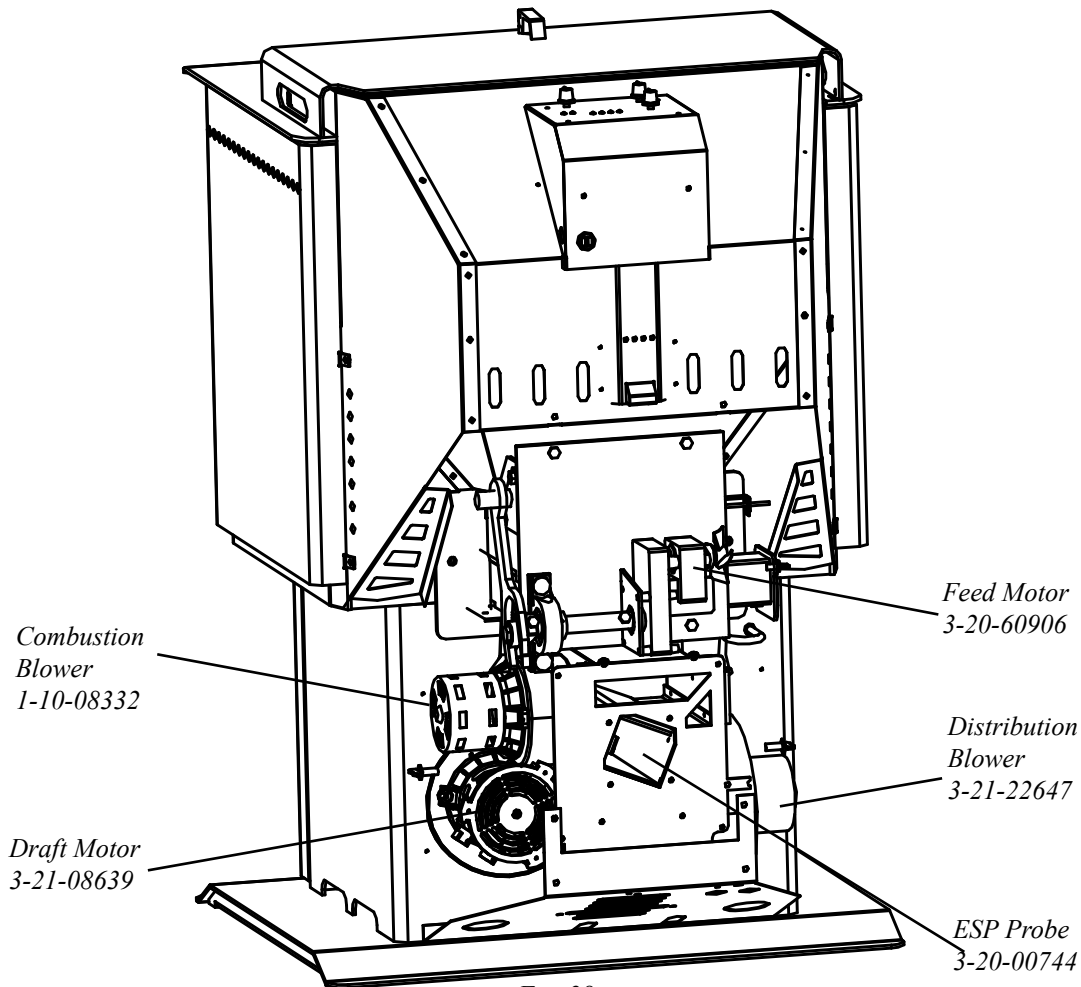

Fig. 28

Fuel

The DVC500 is designed to burn **Anthracite Rice Coal**, which is approximately 3/8" long and wide by 3/16" thick. Anthracite coal is considered either White Ash or Red Ash.

White Ash Coal will have 13 to 14,000 btu's per lb. White ash coal usually has less ash and will burn longer.

Red Ash coal is usually about 12,000 btu's per lb. and is higher in volatiles. Higher volatiles makes the coal easier to light and produces a more yellow flame.

At a very low burn rate the TCP (Temperature Control Probe) may be activated with Red Ash coal, especially if the hopper lid is open or leaking. The TCP senses the temperature of the feeder and feeds coal if the temperature rises too much. This prevents the fire from reaching the coal in the hopper. Red Ash Coal may form klinkers (fused together ash) which may cause grate blockage in severe cases.

Anthracite Coal can be purchased in bags or in bulk. If you buy in bulk, try to have the coal delivered before temperatures reach the freezing level. This is because salt may be added to the coal to keep it from freezing on the truck. This will not affect burning but will promote rust and corrosion.

Some Coal Companies wash their coal better than others to remove fines and dirt. This makes air flow through the coal better and produces less fly ash.

Whether bagged or in bulk, the coal must be dry before loading it into the stove. At a minimum, open bags a few days in advance to allow drying. Buy your bulk coal mid summer to allow plenty of time for drying.

Good, clean, White Ash Coal is the fuel of choice, "however" Red Ash Coal will also burn well. As long as it is **Anthracite**.

Grate System Assembly Or Replacement:

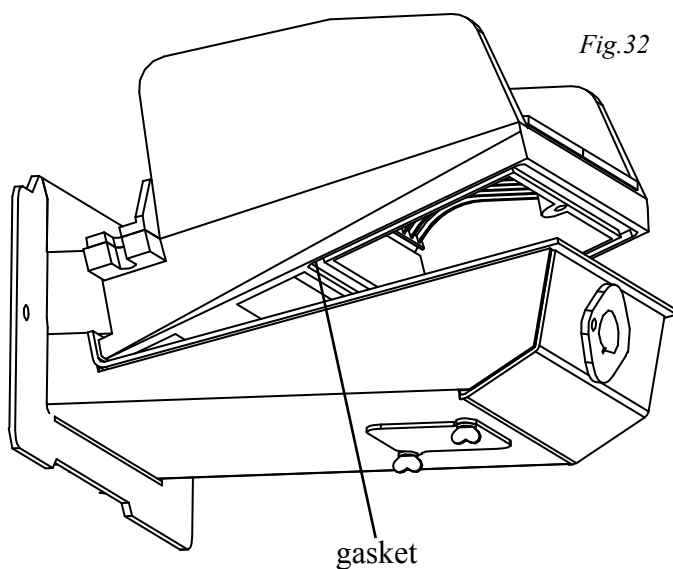
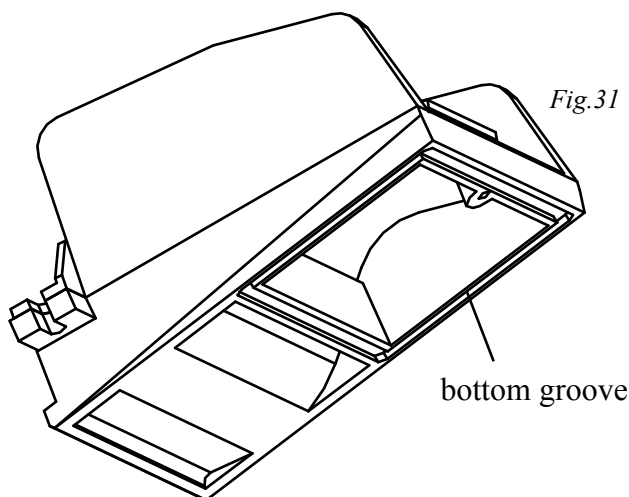
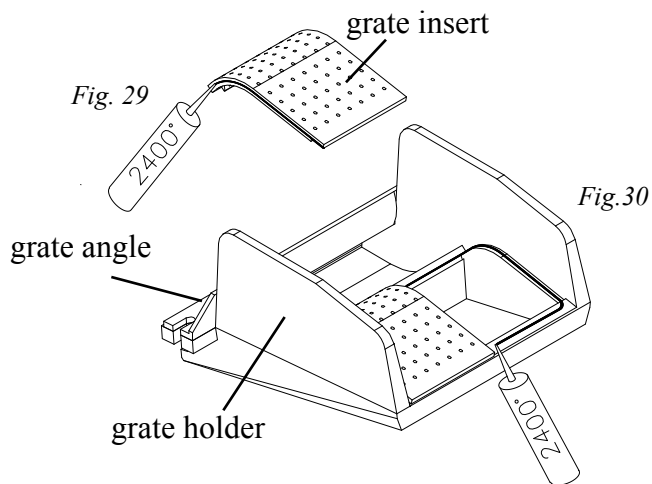

IMPORTANT
Be sure the grate holder is centered and back as far as possible.

The DVC500 grate system is composed of four pieces: the grate holder, (2)-63 hole grate inserts, and grate angle. The grate angle is bolted to the grate holder with (2) 3/8 x 1 1/4 bolts. Before installing the grate holder, 3/8" round gasket must be checked in the groove on the bottom side of the grate holder, as shown in Fig 31. Check to be sure the gasket has not been damaged.

The grate holder must be installed through the top door opening after the feeder has been installed.

Locate the flange at the rear of the grate holder into the slot on the feeder as shown below. Bolt the front end down with the 1/4 x 20 allen bolt and nut provided. The rear end will be locked in place by the flange. Before tightening the bolt, be sure the grate holder is back as far as possible and centered side to side on the feeder opening.

Install grate inserts as shown at left. Seal joints with high temp furnace cement caulking as shown in Fig 30. Insert first grate and squeeze into caulking. Caulk other grate insert, Fig 29, on edge that joins grate already in place. Insert caulked grate in remaining space and squeeze together to make middle joint as tight as possible. Clean any caulking that has pushed out from the joints on top of grates. Let caulking cure before firing.

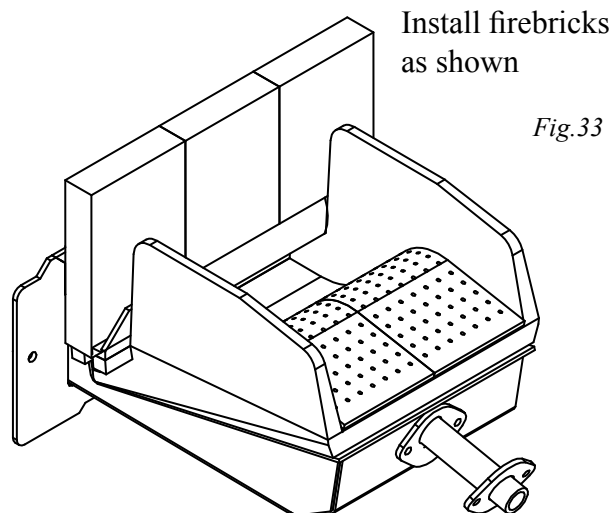

	Daily	Weekly	3 Months	End of Season	Annual Service
Remove Ashes	X				
Add Coal to hopper	X				
Clean Glass		X	X	X	X
Empty Fines Tray		X			
Clean Draft Blower			X	X	X
Clean Exhaust Outlet			X	X	X
Clean Vent Pipe			X	X	X
Clean FSS Tube			X	X	X
Check ESP Probe					X
Check Gaskets			X	X	X
Check Hopper Lid Seal		X	X	X	X
Check Pusher Block for Movement					X
Check for Rust and Corrossion			X	X	X
Clean Combustion Blower Inlet			X	X	X
Clean Stove Exterior		X			
Clean Under Grates			X	X	X
Check Grates for Seal and Warpage			X	X	X
Clean Grate Holes			X	X	X

It is recommended that End of Season Cleaning and the Annual Service are coordinated to happen at the same time for best results.

Wiring Diagram

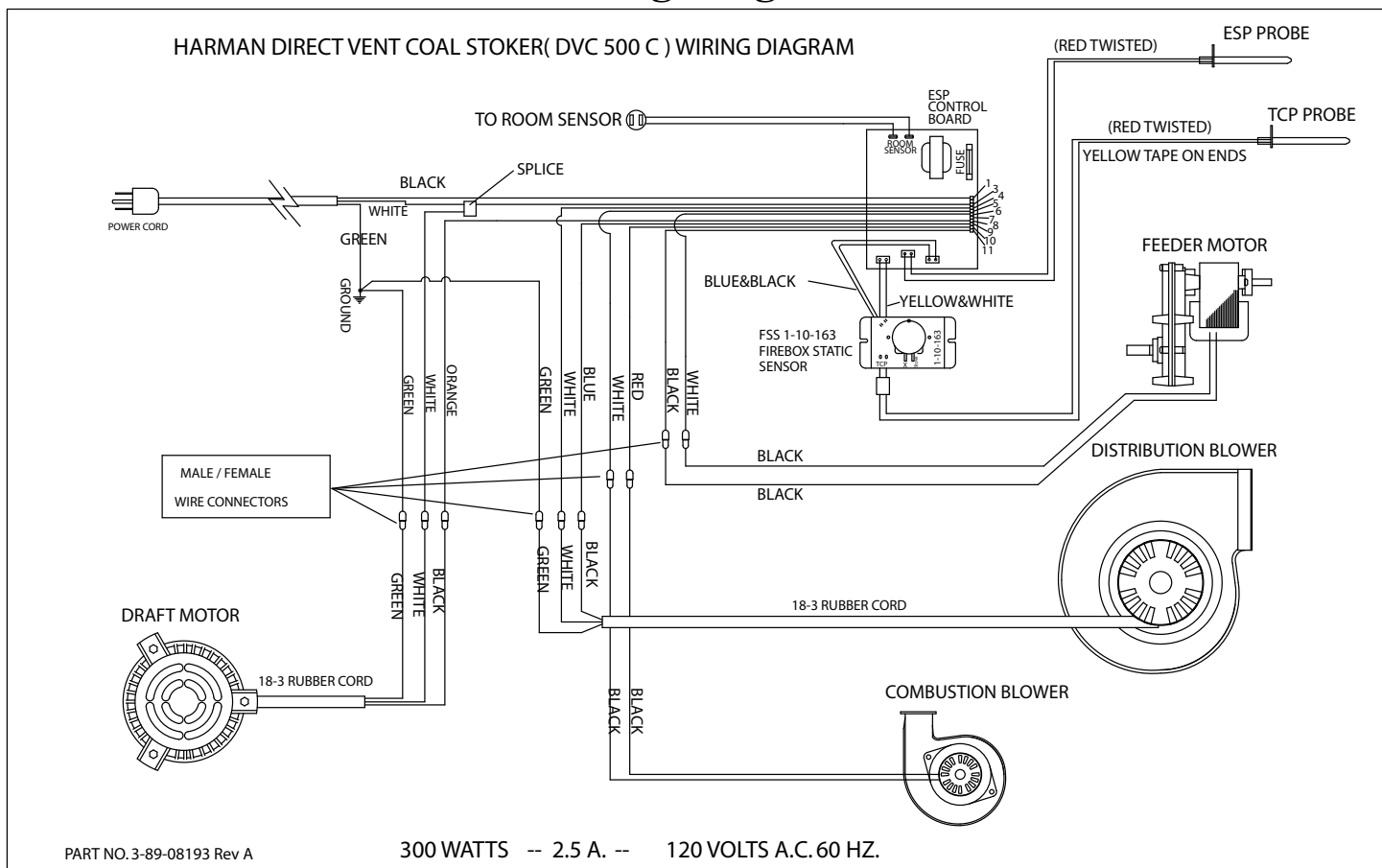

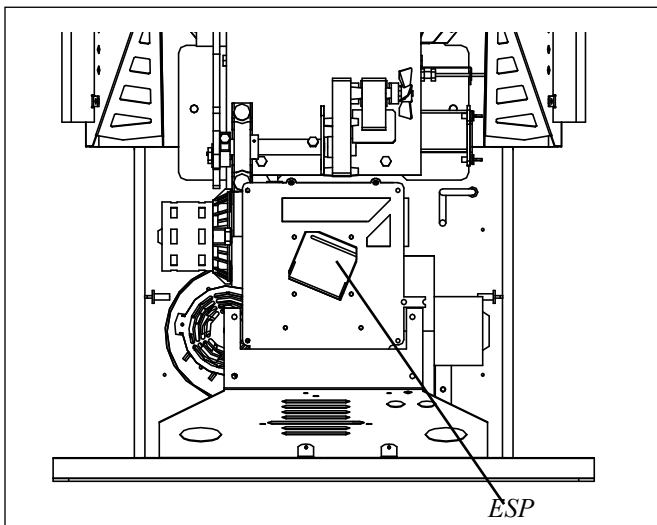

Control and Safety Sensors

ESP

The ESP (Exhaust Sensing Probe) is a temperature sensing probe located in the exhaust outlet. The ESP works with the Control to perform all burn rate functions as well as high and low limit control.

Room Sensor

The Room Sensor is a small temperature sensor placed where you would normally put a thermostat. The Room Sensor is extended to the stove with normal thermostat wire. The Room Sensor works with the ESP and the Control to provide the right size fire.

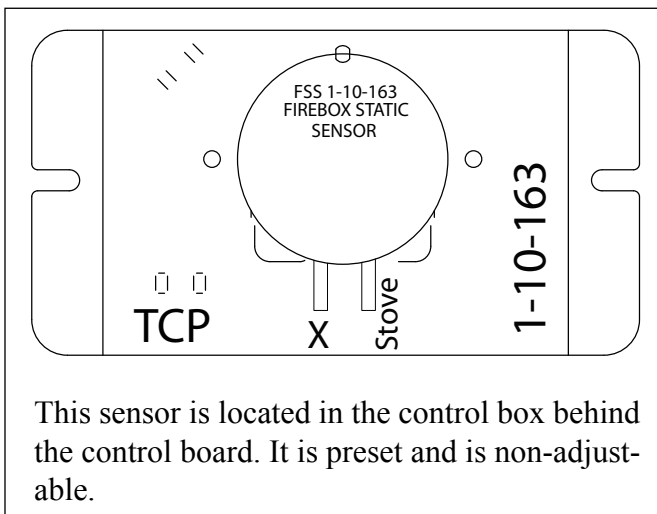

FSS

The FSS (Firebox Static Sensor) is an electronic pressure sensor reading the firebox pressure. The FSS works with the ESP Control to adjust the draft blower speed to compensate for wind and changing house pressures.

TCP

The TCP (Temperature Control Probe) is located on the left side of the feeder. The TCP works with the Control to reduce the feeder temperature if the temperature begins to rise.

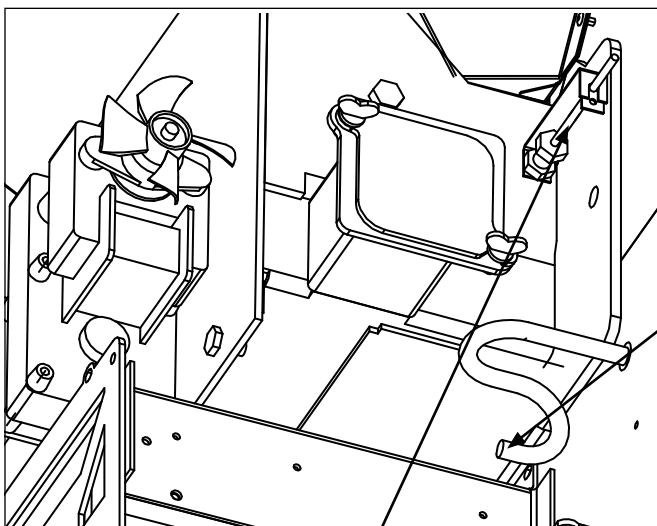

FSS LINE FILTER

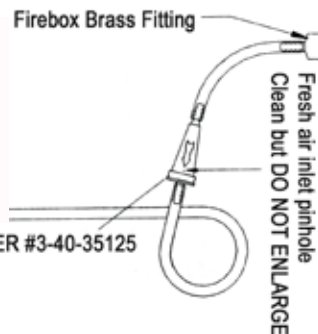

NOTE: FSS LINE FILTER #3-40-35125

The FSS line filter should last years, although dirty or wet coal may reduce the length of time between changes.

TCP

1-70-08600-1 (Black), 1-90-08600-1 (Black w/Door)

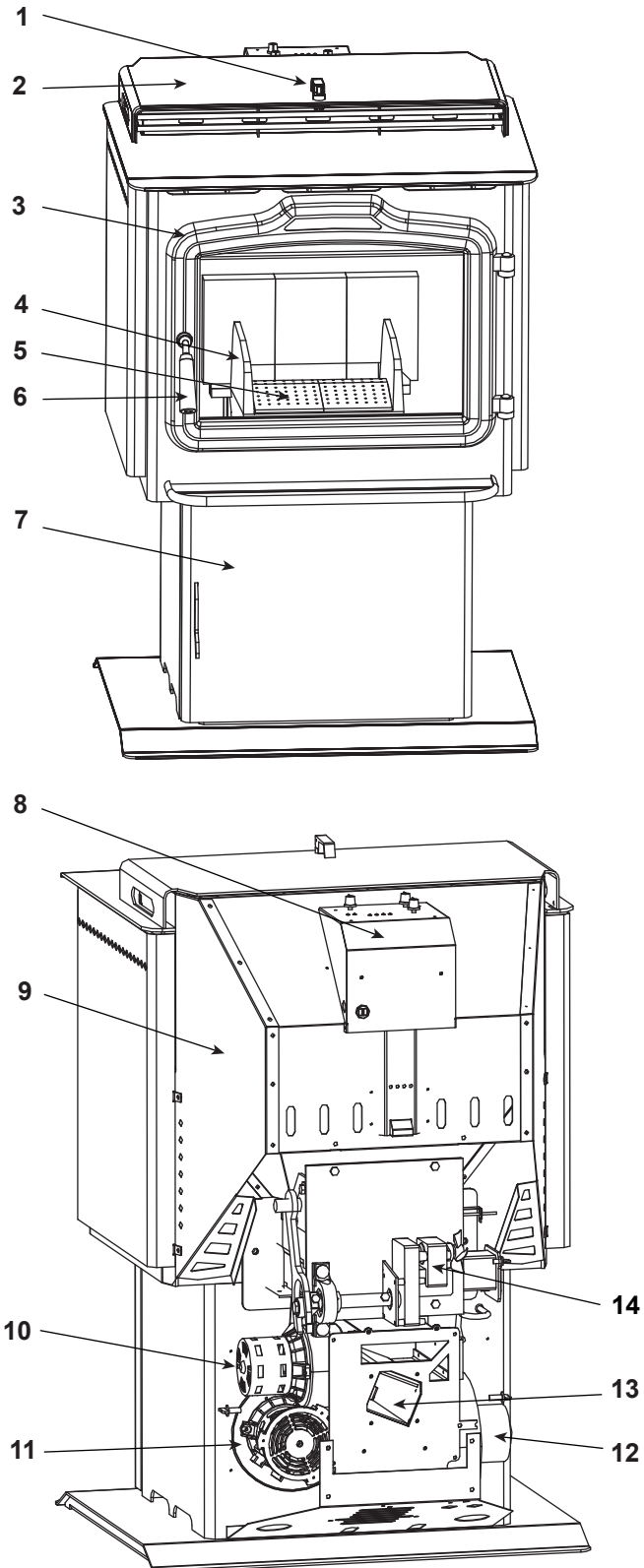

Part number list on following page.

IMPORTANT: THIS IS DATED INFORMATION. When requesting service or replacement parts for your appliance please provide model number and serial number. All parts listed in this manual may be ordered from an authorized dealer.



**Stocked
at Depot**

ITEM	DESCRIPTION	COMMENTS	PART NUMBER	
1	Hopper Lid Swell Latch		3-31-191410	Y
2	Hopper Lid Assembly		1-10-08212A	
3	Door Kit Assembly	Classic Black	1-00-08600-1	
	Door Kit Assembly (Gold)	No longer available	1-00-08600-4	
	Glass, Rect 12-7/16" X 17-5/8"		3-40-08214	Y
4	Grate Holder Assembly		1-10-01000	Y
5	Grate Inserts	Qty. 2 Req.	4-00-08307D	
6	Wooden Handle with screws		1-00-00122	Y
7	Ash Door Assembly		1-10-08205A	
	Ash door Latch Hardware		1-00-38223	Y
8	Control Box Assembly - W/Board & Pressure Switch			
	Control Box		1-10-06486	
	Circuit Board (Requires D-Shaft Knobs)		1-00-05889	Y
	Pressure Switch		1-00-163	Y
9	Hopper Assembly		1-10-08207A	
10	Combustion Blower - W/Flange		1-10-70219720	Y
11	Draft Motor		3-21-08639	Y
12	Distribution Blower		3-21-22647	Y
13	Thermister Probe	Pre 008065076	1-00-00744	Y
		Post 008065076	3-20-00844	Y
14	Feed Motor - 4 rpm		3-20-60906	Y
	1/4"-20 x 2 1/2" Phillips Round Head Zinc Pltd Machine Screw	Pkg of 25	3-30-6007-25	Y
	Ash Lip Trim		3-43-4722386	
	Ash Pan		1-10-08177	Y
	Ash Shield		2-00-06423B	Y
	Brass Elbow		3-40-00121	
	Brick Set		1-00-00382	Y
	Combustion Blower Inlet Cover		1-10-08552W	
	Combustion Blower Seal		3-44-06417	Y
	Combustion Inlet Cover Retainer Assembly		1-10-08553S	Y
	Door (frame only) (Gold)	No longer available	1-10-05165	
	Door (frame only)	Cast	4-00-05165	
	Double Paddle Fan Blade 4-3/4" (old tilt out draft motor)		3-20-502222	Y
	Double Paddle Fan Blade 5" (new style draft motor)		3-20-502221	Y
	Feeder Assembly		1-10-08197A	
	Feeder Cam Block Assembly		1-10-00102A	Y
	Filter, In line for DVC		3-40-35125	
	Fine Tray		2-00-06387S	

Additional service part numbers appear on following page.

IMPORTANT: THIS IS DATED INFORMATION. When requesting service or replacement parts for your appliance please provide model number and serial number. All parts listed in this manual may be ordered from an authorized dealer.



**Stocked
at Depot**

ITEM	DESCRIPTION	COMMENTS	PART NUMBER	
	Gasket, Flue Pipe	Pkg of 3	3-44-06256-3	Y
	Gasket, Glass, 1/4" Round		1-00-2312	Y
	Gasket, Hinge Seal		2-00-06416	Y
	Gasket, Hopper Lid		3-44-06415	Y
	Gasket, Round 1/2" (Load Door)	20 Ft	1-00-1086204	Y
	Glass Clip	Pkg of 4	2-00-05202-4	Y
	#10-24 x 3/8" Alloy Steel Black Oxide Button Head Cap Screw	Pkg of 100	3-30-3011-100	Y
	Gold Air Grill Trim		3-43-08157	
	Handle Assembly		1-00-08176	Y
	Hercules Grate Cement	12 oz. Tube	3-42-08308	
	Paw Bolt		4-31-08055	Y
	Pillow block Bearing		3-31-06238	Y
	Pusher Block, Aluminum		3-50-06438	Y
	Room Sensor		3-20-00906	Y
	Silicone foam 1/16" - grey (hopper lid)		3-44-08551	Y
	Silicone Tubing For In Line Filter		1-00-5113574	Y
	Silicone, Red Sponge W/PSA (Old Units)		3-44-08215	Y
	TCP Probe (Yellow Thermister Probe)	Pre 008065076	3-20-08272	Y
		Post 008065076	3-20-00844	Y
	Termination Trim Collar	Qty. 2 Req.	2-00-06326	
	Tile frame assembly 12 X 6	No longer available	1-00-08617	
	Tilit Draft Motor		3-21-42940	Y
Tile Pack				
	Brushed Stainless Steel Plate 12 X 6	Deer	1-00-06732-2	
	Ceramic Tile 12 X 6 (No longer available)	Pheasants	3-43-120601	
		Deer	3-43-120602	
		Mallards	3-43-120603	
		Old Mill	3-43-120604	
		Cottage	3-43-120605	
		Eagle	3-43-120606	
		Bridge	3-43-120607	
		Bear	3-43-120608	
		Lighthouse	3-43-120609	
		Trout	3-43-120610	
	Slate Tile 12 X 6	Floral	3-43-06731-11	
		Horse Riders	3-43-06731-12	
		Deer	3-43-06731-2	
		Lighthouse	3-43-06731-9	

Specifications

Weight	500 Pounds
BTU Output Range	7000 to 75,000
Heating Capacity	2200 Square Feet
Fuel	Anthracite Rice Coal
Hopper Capacity	93 Pounds
Distribution Blower Size	135 cfm
Flue	4" Harman DVC Vent
Wattage	295 Watts
Control	ESP with Micro-processor
Width	25 ³ / ₄ "
Height	40 ³ / ₄ "
Depth	29"

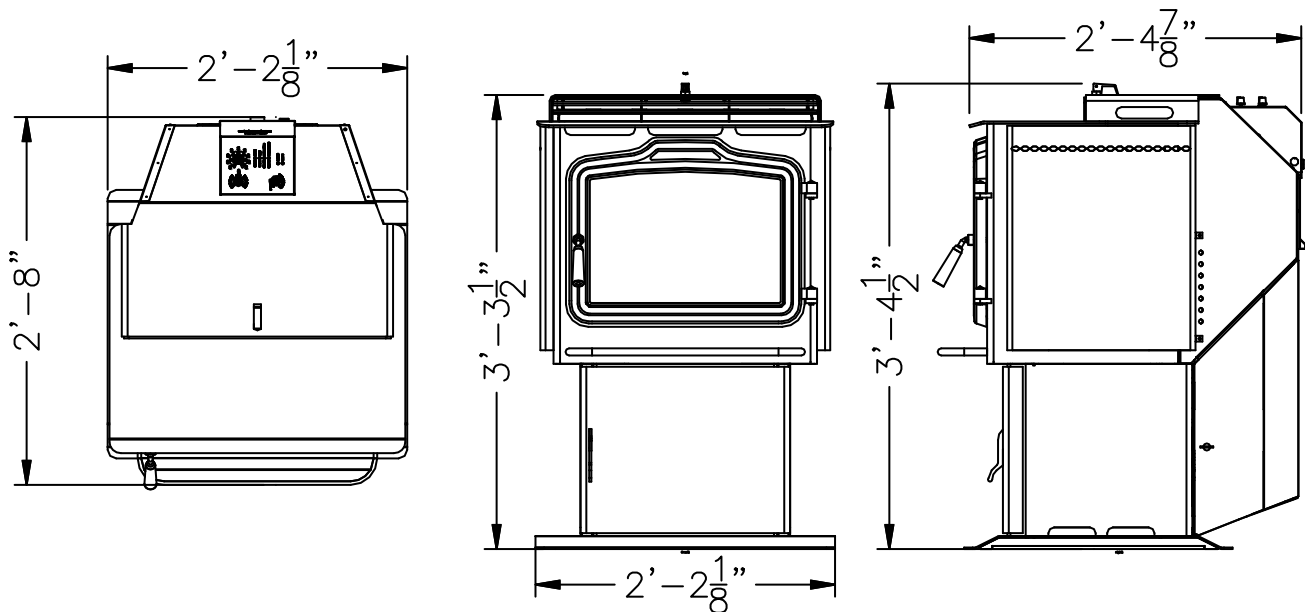

DVC 500-C

Firebox Static Pressure

Safety Protocol

The DVC-500 operates with a negative pressure firebox as a safety feature. The control continuously adjusts the draft motor speed to maintain a safe firebox negative static.

NOTE: Observe the intensity of the Draft Motor light on the control panel in comparison with the Feed Motor light when it is on. When the appliance and venting system are clean, the indicator light is much dimmer than the others. This is because there is lower voltage flowing to the draft motor. As ashes build up, the light will get brighter because the draft motor needs to run faster in order to maintain the negative pressure in the firebox. When the indicator light for the draft motor appears as bright as the rest of the lights, it is a good indication that it's time to clean the appliance and the venting.

If the circuit board is flowing full line voltage to the Draft Motor, and the negative pressure in the firebox is too low, the following safety protocol will begin.

Stage 1

When the safety switch senses a loss of negative pressure in the firebox for more than 68 seconds the following happens:

The combustion blower will reduce in speed. During this cool down period the feeder is allowed to operate. If needed, the feeder can operate for up to 3 minutes.

After 72 minutes, if the safety switch has not sensed another pressure loss, the unit will automatically go back to the control board setting.

If the safety switch senses a loss of negative pressure anytime during the STAGE 1 Protocol, the unit automatically goes to the STAGE 2 Protocol.

Stage 2:

If Stage 1 has already begun and the negative pressure is lost:

The status light will start to blink (2 blinks).

The combustion blower and feeder motor will shut off. These motors will remain off for a 5 minute cool-down period. After five minutes, those components will restart at a reduced feed rate (30 seconds max.) for 72 minutes.

After 72 minutes, if the safety switch has not sensed another pressure loss, the unit will automatically go back up to Stage 1.

The status light will continue to blink (2 blinks) throughout Stage 1 and Stage 2.

If the safety switch senses a loss of negative pressure anytime during the Stage 2 Protocol, the unit automatically goes to the Stage 3 Protocol.

Stage 3:

During stage 2, if another loss of negative pressure is sensed;

The status light will continue to blink 2 blinks.

The Distribution Blower will be cycling "high" to "low" as an audible warning.

The Combustion Blower and Feeder Motor will shut off.

When the unit reaches Stage 3 these motors will not restart.

The Draft Motor will continue to run at maximum voltage, but the fire will go out.

[At any time, the 2 blink status can be reset by disconnecting the power to the unit for a few seconds.]

CAUTION

Resetting a 2 Blink Status likely indicates that service is required.

Clean the appliance and the venting system thoroughly. If the error persists, contact your dealer for more advanced service.

Causes And/Or Reasons For (2-blink) Shutdown:

The DVC-500 operates with a negative pressure firebox as a safety feature. Any loss of this negative pressure will start the safety protocol, (A two blink status warning)

The following list of potential reasons for warnings is in order of most likely to least likely to occur:

1. **Opening the viewing door or the ash door** for long periods of time without turning the feed adjuster knob to the "ASH OUT" position.

2. **Blocked or partially blocked flue pipe.** This is generally a slow buildup and may only cause the unit to go in and out of Stage 1. Although as the condition worsens, the unit will continue to step down until it goes out.

3. **Draft motor fan blades dirty.** This is generally a slow buildup and may only cause the unit to go in and out of Stage 1. Although as the condition worsens, the unit will Continue to step down until it goes out.

4. **Draft motor fan cover plate** not installed or not in proper position. (Behind ash pan)

5. **Gasketing problems** with the viewing or ash removal door.

6. **Grate clean-out cover** not closed properly, Fig.26.

7. **Grate inserts** are extremely loose or out of alignment, fig. 30.

8. **Coal ash building up** behind the ash pan to a point where the ash door is sprung and not sealing when latched.

9. **Transparent tubing** from firebox to sensing switch is off or blocked with fly ash.

10. **Poor seal on the hopper lid** (usually caused by coal under hopper lid edge gasketing after fueling).

11. **Fines tray cover** not closed properly, fig. 20.

12. **Poor or improper flue termination**, other than those shown in the owners manual.

13. **Too high of negative pressure** in the area being heated. This is usually caused by the area being too tight and using many exhausting appliances (range hood, clothing dryer, exhaust fans, etc.). Often this condition can be caused by heavy and gusting winds hitting the outside, creating a negative pressure inside. This internal to external pressure difference may cause the unit to go in and out of Stage 1.

14. **Faulty computer circuit** or disconnected wiring between control board and safety switch.

15. **Faulty safety switch** (not field adjustable).

16. **Draft motor failure** - there is electricity to the motor but it will not turn.

[At any time, the 2 blink status can be reset by disconnecting the power to the unit for a few seconds.]

Hearth & Home Technologies Inc. LIMITED LIFETIME WARRANTY

Hearth & Home Technologies Inc., on behalf of its hearth brands ("HHT"), extends the following warranty for HHT gas, wood, pellet, coal and electric hearth appliances that are purchased from an HHT authorized dealer.

WARRANTY COVERAGE:

HHT warrants to the original owner of the HHT appliance at the site of installation, and to any transferee taking ownership of the appliance at the site of installation within two years following the date of original purchase, that the HHT appliance will be free from defects in materials and workmanship at the time of manufacture. After installation, if covered components manufactured by HHT are found to be defective in materials or workmanship during the applicable warranty period, HHT will, at its option, repair or replace the covered components. HHT, at its own discretion, may fully discharge all of its obligations under such warranties by replacing the product itself or refunding the verified purchase price of the product itself. The maximum amount recoverable under this warranty is limited to the purchase price of the product. This warranty is subject to conditions, exclusions and limitations as described below.

WARRANTY PERIOD:

Warranty coverage begins on the date of original purchase. In the case of new home construction, warranty coverage begins on the date of first occupancy of the dwelling or six months after the sale of the product by an independent, authorized HHT dealer/ distributor, whichever occurs earlier. The warranty shall commence no later than 24 months following the date of product shipment from HHT, regardless of the installation or occupancy date. The warranty period for parts and labor for covered components is produced in the following table.

The term "Limited Lifetime" in the table below is defined as: 20 years from the beginning date of warranty coverage for gas appliances, and 10 years from the beginning date of warranty coverage for wood, pellet, and coal appliances. These time periods reflect the minimum expected useful lives of the designated components under normal operating conditions.

Warranty Period		HHT Manufactured Appliances and Venting							Components Covered
Parts	Labor	Gas	Wood	Pellet	EPA Wood	Coal	Electric	Venting	
1 Year		X	X	X	X	X	X	X	All parts and material except as covered by Conditions, Exclusions, and Limitations listed
2 years				X	X	X			Igniters, electronic components, and glass
		X	X	X	X	X			Factory-installed blowers
				X					Molded refractory panels
3 years				X					Firepots and burnpots
5 years	1 year			X	X				Castings and baffles
7 years	3 years		X	X	X				Manifold tubes, HHT chimney and termination
10 years	1 year	X							Burners, logs and refractory
Limited Lifetime	3 years	X	X	X	X	X			Firebox and heat exchanger
90 Days		X	X	X	X	X	X	X	All replacement parts beyond warranty period

See conditions, exclusions, and limitations on next page.

WARRANTY CONDITIONS:

- This warranty only covers HHT appliances that are purchased through an HHT authorized dealer or distributor. A list of HHT authorized dealers is available on the HHT branded websites.
- This warranty is only valid while the HHT appliance remains at the site of original installation.
- Contact your installing dealer for warranty service. If the installing dealer is unable to provide necessary parts, contact the nearest HHT authorized dealer or supplier. Additional service fees may apply if you are seeking warranty service from a dealer other than the dealer from whom you originally purchased the product.
- Check with your dealer in advance for any costs to you when arranging a warranty call. Travel and shipping charges for parts are not covered by this warranty.

WARRANTY EXCLUSIONS:

This warranty does not cover the following:

- Changes in surface finishes as a result of normal use. As a heating appliance, some changes in color of interior and exterior surface finishes may occur. This is not a flaw and is not covered under warranty.
- Damage to printed, plated, or enameled surfaces caused by fingerprints, accidents, misuse, scratches, melted items, or other external sources and residues left on the plated surfaces from the use of abrasive cleaners or polishes.
- Repair or replacement of parts that are subject to normal wear and tear during the warranty period. These parts include: paint, wood, pellet and coal gaskets, firebricks, grates, flame guides, light bulbs, batteries and the discoloration of glass.
- Minor expansion, contraction, or movement of certain parts causing noise. These conditions are normal and complaints related to this noise are not covered by this warranty.
- Damages resulting from: (1) failure to install, operate, or maintain the appliance in accordance with the installation instructions, operating instructions, and listing agent identification label furnished with the appliance; (2) failure to install the appliance in accordance with local building codes; (3) shipping or improper handling; (4) improper operation, abuse, misuse, continued operation with damaged, corroded or failed components, accident, or improperly/incorrectly performed repairs; (5) environmental conditions, inadequate ventilation, negative pressure, or drafting caused by tightly sealed constructions, insufficient make-up air supply, or handling devices such as exhaust fans or forced air furnaces or other such causes; (6) use of fuels other than those specified in the operating instructions; (7) installation or use of components not supplied with the appliance or any other components not expressly authorized and approved by HHT; (8) modification of the appliance not expressly authorized and approved by HHT in writing; and/or (9) interruptions or fluctuations of electrical power supply to the appliance.
- Non-HHT venting components, hearth components or other accessories used in conjunction with the appliance.
- Any part of a pre-existing fireplace system in which an insert or a decorative gas appliance is installed.
- HHT's obligation under this warranty does not extend to the appliance's capability to heat the desired space. Information is provided to assist the consumer and the dealer in selecting the proper appliance for the application. Consideration must be given to appliance location and configuration, environmental conditions, insulation and air tightness of the structure.

This warranty is void if:

- The appliance has been over-fired or operated in atmospheres contaminated by chlorine, fluorine, or other damaging chemicals. Over-firing can be identified by, but not limited to, warped plates or tubes, rust colored cast iron, bubbling, cracking and discoloration of steel or enamel finishes.
- The appliance is subjected to prolonged periods of dampness or condensation.
- There is any damage to the appliance or other components due to water or weather damage which is the result of, but not limited to, improper chimney or venting installation.

LIMITATIONS OF LIABILITY:

- The owner's exclusive remedy and HHT's sole obligation under this warranty, under any other warranty, express or implied, or in contract, tort or otherwise, shall be limited to replacement, repair, or refund, as specified above. In no event will HHT be liable for any incidental or consequential damages caused by defects in the appliance. Some states do not allow exclusions or limitation of incidental or consequential damages, so these limitations may not apply to you. This warranty gives you specific rights; you may also have other rights, which vary from state to state. EXCEPT TO THE EXTENT PROVIDED BY LAW, HHT MAKES NO EXPRESS WARRANTIES OTHER THAN THE WARRANTY SPECIFIED HEREIN. THE DURATION OF ANY IMPLIED WARRANTY IS LIMITED TO DURATION OF THE EXPRESSED WARRANTY SPECIFIED ABOVE.

HARMANTM
HOME HEATING

Proudly Printed On 100% Recycled Paper

