

# **SERVICE MANUAL**

## **DUAL TECHNOLOGY FINISHER**

**MODEL 1921,1922**

# SEQUENCE OF OPERATION

## DUAL TECHNOLOGY FINISHER

1921	208VAC	60 HZ.	3 PHASE
1922	240VAC	60 HZ.	3 PHASE

POWER SUPPLY	Electrical power to be supplied to the oven by a four conductor service for three phase. Black conductor is hot. Red conductor is hot. Orange conductor is hot Green conductor is ground.
MAIN FAN CIRCUIT	Power is permanently supplied through the 10 amp fuses, through the normally closed oven cavity hi-limit thermostat, to the normally open main power switch and to terminal number 1 of the 30 minute cool down timer. Closing the main power switch enables the 30 minute cool down timer. The 30 minute cool down timer supplies line voltage to the coil of the main fan relay, its contacts now close, supplying 208/240VAC to the main fan motor. Voltage is also supplied to the primary of the control transformer, the conveyor motor, the oven control and the infrared heater switch. NOTE: Model 1922 ovens use a 240VAC to 208VAC step down transformer for the main fan motor
TEMPERATURE CONTROL	Closing the main power switch supplies 208/240VAC to the primary of the control transformer. Secondary voltage, 24VAC, is supplied to the oven control. The oven control is set to desired temperature. The thermocouple will provide varying millivolts to the oven control. The oven control supplies 208/240VAC to the coil of the heater relay at intermittent intervals to maintain the desired temperature. The display on the oven control will indicate when the main heater relay is energized. NOTE: The display also indicates oven temperature.
INFRARED HEAT	Closing the infrared heater switch supplies line voltage to the coil of the infrared heater relay, its contacts now close, supplying 208/240VAC to the infrared heaters.
CONVEYOR DRIVE	Closing the main power switch supplies 208/240VAC to the primary of the control transformer and, through the air pressure switch, the Infrared heater switch, to the conveyor motor. Secondary voltage, 24VAC, is supplied to the oven control. Setting the oven control to the desired time outputs voltage, through a reversing switch and capacitor, to the conveyor motor. NOTE: The conveyor system uses a hall effect sensor and magnet to prove operation of the conveyor motor. If the conveyor motor is not running, "BELT JAM" is indicated on the display.
AUTOMATIC COOL DOWN	When the machine is started, the time delay relay timing circuit is enabled, permitting the main fan to operate for approximately 30 minutes after the machine is shut off, to cool the machine. The 30-minute time delay relay will keep the coil of the main fan relay energized, maintaining operation of the main fan motor for 30 minutes.

# SCHEMATIC DIAGRAM MODEL 1921

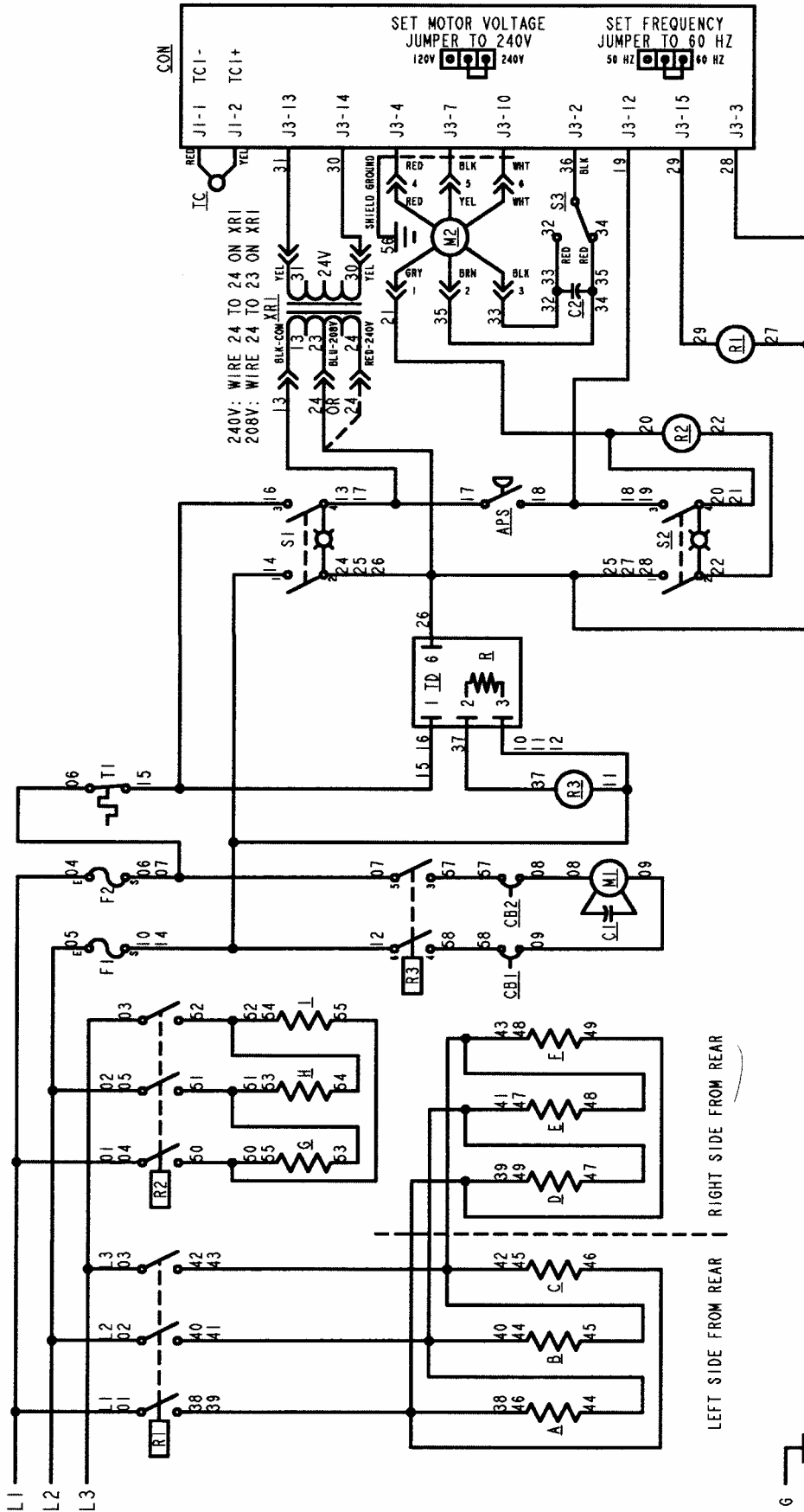

**Lincoln**  
Foodservice Products, Inc.  
FORT WAYNE, INDIANA

DTF FINISHER

2806487B

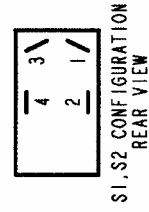

- R1 - RELAY, MAIN HEATER
- R2 - RELAY, INFRARED HEATER
- R3 - RELAY, MAIN FAN
- S1 - SWITCH, MAIN
- S2 - SWITCH, INFRARED HEATER
- S3 - SWITCH, CONVEYOR REVERSING
- TC - THERMOSTAT, TYPE K
- TI - THERMOCOUPLE, OVEN HIGH LIMIT
- TD - TIME DELAY, 30 MINUTES
- XRI - TRANSFORMER, CONTROL

- A-F - HEATER, MAIN, 1000 W
- APS - AIR PRESSURE SWITCH
- C1 - CAPACITOR, MAIN FAN
- C2 - CAPACITOR, CONVEYOR MOTOR
- CB1, CB2 - CIRCUIT BREAKER, M1, 3 AMP
- CON - CONTROL, OVEN
- F1, F2 - FUSE, MOTOR & CONTROLS
- G-I - HEATER, INFRARED, 1000 W
- M1 - MOTOR, MAIN FAN
- M2 - MOTOR, CONVEYOR

# SCHEMATIC DIAGRAM MODEL 1922

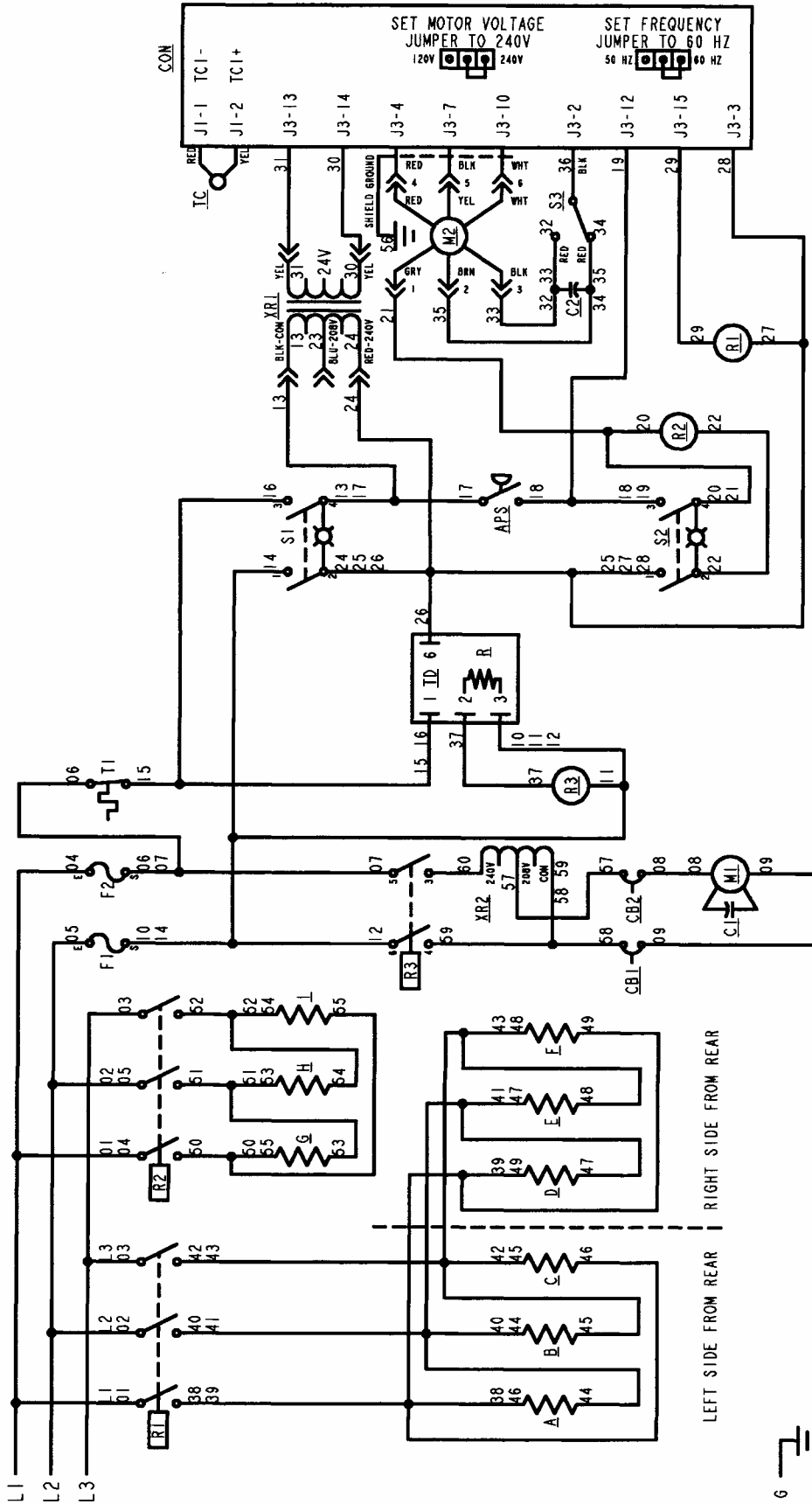

**Lincoln**  
**Foodservice Products, Inc.**  
 FORT WAYNE, INDIANA  
 DTF FINISHER

2806501A

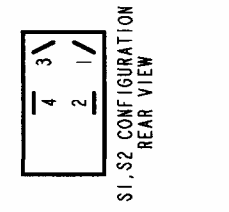

- R1 - RELAY, MAIN HEATER
- R2 - RELAY, INFRARED HEATER
- R3 - RELAY, MAIN FAN
- S1 - SWITCH, MAIN
- S2 - SWITCH, INFRARED HEATER
- S3 - SWITCH, CONVEYOR REVERSING
- TC - THERMOCOUPLE, TYPE K
- TI - THERMOSTAT, OVEN HIGH LIMIT
- TD - TIME DELAY, 30 MINUTES
- XR1 - TRANSFORMER, CONTROL
- XR2 - AUTOFORMER, 240-208 VOLT

- A-F - HEATER, MAIN, 1000 W
- APS - AIR PRESSURE SWITCH
- C1 - CAPACITOR, MAIN FAN
- C2 - CAPACITOR, CONVEYOR MOTOR
- CB1, CB2 - CIRCUIT BREAKER, M1, 3 AMP
- CON - CONTROL, OVEN
- F1, F2 - FUSE, MOTOR & CONTROLS
- G-I - HEATER, INFRARED, 1000 W
- M1 - MOTOR, MAIN FAN
- M2 - MOTOR, CONVEYOR

## TROUBLESHOOTING GUIDE

1921  
1922

208 VAC  
240 VAC

60 HZ.  
60 HZ.

3 PHASE  
3 PHASE

SYMPTOM	POSSIBLE CAUSE	EVALUATION
Oven fan will not run	Incoming power supply	Check circuit breakers. Reset if required. Call power co. if needed.
	Fuses, 10 Amp, motor and controls	Check, replace if necessary.
	Fuse holder	Check, replace if necessary.
	Hi-limit thermostat, Oven cavity	Terminals are normally closed. If open, reset thermostat and retest. If thermostat will not hold for maximum oven temperature, and oven is not exceeding temperature setting, check for proper location of capillary bulb in its spring holder. If the capillary checks okay, replace the hi-limit thermostat.
	Switch, main power	Check continuity between switch terminals. Replace switch as needed.
	30 minute time delay relay	Check for supply voltage to 30 minute time delay relay at terminals #1 and #6. If no voltage is present, trace wiring back to main power switch. If there is supply voltage at terminals #1 and #6, check for output voltage at terminals #2 and #3. If there is incoming voltage but no output voltage, and the main power switch is on, replace the 30 minute time delay relay.
	Relay, main fan	Check for supply voltage to relay contacts, if no voltage is present, trace wiring back to power supply. Check for supply voltage to the coil of the main fan relay. If no voltage is present, trace wiring back to the 30 minute time delay relay. If voltage is present, check to insure contacts are closing. Replace as needed.
	Transformer, Motor (MODEL 1922 ONLY)	Check for 240 VAC supply to the transformer primary. If no voltage is present, trace wiring back to relay. If 240VAC is present at transformer primary, check for 208VAC at the transformer secondary. If there is primary voltage, but no secondary voltage, replace transformer.
	Circuit breaker(s), 3A.	Push and reset circuit breakers. Check for voltage to the circuit breaker. If no voltage is present, trace wiring back to the main fan relay. If there is voltage present, proceed. Check for continuity through the circuit breaker, if the circuit breaker has been reset and there is no continuity through the circuit breaker, replace the circuit breaker.
	Main fan motor	Check for supply voltage at motor. If no voltage is present, trace wiring back to circuit breakers. WITH POWER OFF: Check for opens, shorts or grounds. Turn fan blade to check for locked rotor.
	Capacitor	Check for shorts or grounds. WARNING: Capacitor has a stored charge, discharge before testing.
Oven will not heat	Main fan motor	Check for main fan operation. If it is not operating, refer to "Oven fan will not run".
	Air pressure switch	This normally open switch should close when the main fan is activated. Refer to the "Removal and installation" section for proper adjustment. Replace as needed.

	Control transformer	Check for 208/240VAC supply to the primary of the control transformer. If no voltage is present, trace wiring back to the main power switch. If voltage is present, check for 24VAC at the transformer secondary. If there is primary voltage, but no secondary voltage, replace the control transformer.
	Oven control	Check for 24VAC supply to control. If no voltage is present, trace wiring back to control transformer. If 24VAC is present, check for a read-out on the display. If there is 24VAC supplied, but there is no read-out on the control display, replace the oven control. If there is a read-out on the control, set the control to maximum temperature (see installation operations manual for temperature adjustment). With the control set at maximum temperature, check for supply voltage to the oven control at terminals J3-12 and J3-3. If there is no voltage present, trace wiring back to the air pressure switch. If there is voltage present, check for output voltage at the Main heater relay (R1). If there is voltage at the Main heater relay, proceed to "Main heater relay" for next check. If there is no voltage at the Main heater relay, trace wiring back to the oven control. If there is no voltage output at the oven control, check the read-out on the control. If the control reads "PROBE FAIL", this indicates that the thermocouple has failed or become disconnected from the oven control.
	Thermocouple	Check to be sure that the thermocouple is securely connected to the oven control. If the thermocouple is connected to the oven control, and the control indicates "PROBE FAIL", disconnect the thermocouple from the oven control and measure the resistance of the thermocouple. The thermocouple should read approx. 11Ω. If these readings are not achieved, replace the thermocouple. If these readings are correct, proceed.
	Oven control	If the thermocouple checks good, but the oven control display indicates that there is a thermocouple failure, replace the oven control. If the oven control indicates a temperature reading but the oven will not heat, proceed.
	Thermocouple	WITH POWER ON AND THERMOCOUPLE ATTACHED TO THE OVEN CONTROL: Measure the DC millivolt output of the thermocouple. Refer to the thermocouple chart (located in the "Removal" section of the manual) for proper millivolt readings. If these readings are not achieved, replace thermocouple.
	Oven control	If the thermocouple checks good, but there is no voltage output to the Main heater relay, replace the oven control. If there is voltage output to the Main heater relay, proceed.
	Main heater relay	Check for supply voltage to the relay coil. If voltage is present and the relay will not activate, replace the Main heater relay. Also check each relay contact for high voltage input and output.
	Heating element(s)	Check the Amp draw on each power leg for proper load. Check the specification plate for rating information. If the amp draw is high or low, check the individual elements for opens, shorts and proper resistance. WITH POWER OFF: To check resistance of the elements, remove all leads from the elements and use

		<p>a digital multimeter.  The element resistance should be as follows:  208V – 43 ohms approx.  240V – 57 ohms approx.  Replace heating elements as needed.</p>
No Infrared Heating	Main fan motor	Check for main fan operation. If it is not operating, refer to “Oven fan will not run”.
	Air pressure switch	Check for 208/240VAC to the air pressure switch. If no voltage is present, trace wiring back to main power switch. This normally open switch should close when the main fan is activated. Refer to the “Removal and installation” section for proper adjustment. Replace as needed.
	Switch, Infrared heater	Check for 208/240VAC to the Infrared heater switch. If no voltage is present, trace wiring back to the air pressure switch. WITH POWER OFF: Check continuity between switch terminals. Replace switch as needed.
	Infrared heater relay	Check for supply voltage to the relay coil. If no voltage is present, trace wiring back to Infrared heater switch. If voltage is present and the relay will not activate, replace the Infrared heater relay. Also check each relay contact for high voltage input and output.
	Infrared Heating element(s)	<p>Check the Amp draw on each power leg for proper load. Check the specification plate for rating information. If the amp draw is high or low, check the individual elements for opens, shorts and proper resistance.  WITH POWER OFF: To check resistance of the elements, remove all leads from the elements and use a digital multimeter.  The element resistance should be as follows:  208V – 45 ohms approx.  240V – 58 ohms approx.  Replace heating elements as needed.</p>
Oven heats with switch off	Main heater relay or Infrared heater relay	The Main heater relay or Infrared heater relay has probably failed in the closed position. If there is no voltage to the operating coil, but there is high voltage at the relay output, replace the heater relay.
Intermittent heating	Thermal/overload of motor	The main fan motor is equipped with internal thermal protection and will cease to operate if overheating occurs. As the motor overheats and then cools, this will cause the oven to cycle on and off intermittently. Improper ventilation or lack of preventive maintenance may cause this. Also, most of the problems listed under “Oven will not heat” can cause intermittent failure.
Conveyor will not run	NOTE: Display will indicate “Belt Jam”	
	Power supply	Check circuit breakers, reset if required. Check power plug to be sure it is firmly in receptacle. Measure incoming power, call power co. if needed.
	Fuse, 10 Amp	Check, replace if necessary.
	Fuse holder	Check, replace if necessary.
	Hi-limit thermostat, oven cavity	Terminals are normally closed. If open, reset thermostat and retest. If thermostat will not hold for maximum oven temperature, and oven is not exceeding temperature setting, check for proper location of capillary bulb in its spring holder. If the capillary checks okay, replace the hi-limit thermostat.

	Switch, Main Power	WITH POWER OFF: Check continuity between switch terminals. Replace switch as needed.
	Control transformer	Check for supply voltage to the primary of the control transformer. If no voltage is present, trace wiring back to the oven power relay. If voltage is present, check for 24 VAC at the transformer secondary. If there is primary voltage but no secondary voltage, replace control transformer.
	Air pressure switch	Check for 208/240VAC to the air pressure switch. If no voltage is present, trace wiring back to main power switch. This normally open switch should close when the main fan is activated. Refer to the "Removal and installation" section for proper adjustment. Replace as needed.
	Switch, Infrared heater	Check for 208/240VAC to the Infrared heater switch. If no voltage is present, trace wiring back to the air pressure switch. WITH POWER OFF: Check continuity between switch terminals. Replace switch as needed.
	Conveyor motor	Check for supply voltage to the conveyor motor. If no voltage is present, trace wiring back to the primary of the control transformer. If voltage is present and the motor will not run, check the motor windings for opens or shorts. WITH POWER OFF: Check the motor windings as follows: Grey to black - 236 ohms approx. Grey to brown - 236 ohms approx. Brown to black - 472 ohms approx. If any of the above fails, replace conveyor motor.
	Capacitor, conveyor motor	Check for shorts or grounds. Replace capacitor as needed. WARNING: Capacitor has a stored charge, discharge before testing.
	Switch, conveyor reversing	Check continuity between switch terminals. Replace switch as needed.
	Oven control	If there is supply voltage to the motor, and the motor, motor capacitor, and reversing switch check good, replace the oven control.
Conveyor motor runs, but there is no speed display	Oven control	Check for output voltage from oven control to hall effect sensor (sensor is located in conveyor motor). Measure voltage at the motor connector, red wire and yellow wire. Voltage should be approx. 10VDC. If no voltage is present, trace wiring back to oven control. If there is no voltage present at the oven control, replace the oven control.
	Conveyor motor	If there is voltage supplied to the hall effect sensor, check for a frequency output from the hall effect sensor. Measure frequency across the yellow and white wires at the motor connector. Frequency reading should be approx. 25 – 100 Hz. If these readings are not achieved, replace conveyor motor. If the readings are achieved, proceed.
	Oven control	If the hall effect sensor readings are correct, but there is no speed indicated on the display, replace the oven control.



# REMOVAL, INSTALLATION AND ADJUSTMENT

## DUAL TECHNOLOGY FINISHER

### CAUTION!

BEFORE REMOVING OR INSTALLING ANY COMPONENT IN THE DUAL TECHNOLOGY FINISHER, BE SURE TO DISCONNECT THE ELECTRICAL POWER SUPPLY.

### MOTOR, MAIN FAN - REPLACEMENT

1. Shut off power at main breaker.
2. Remove conveyor and finger assemblies from oven (see installation operations manual).
3. Remove front plenum assembly. Measure location of main fan on motor shaft for reassembly. Loosen two set screws and remove main fan from motor shaft.
4. Remove oven top and rear cover. Disconnect wiring from motor. Remove motor and motor mount assembly from back of oven.
5. Measure proper location of cooling fan on motor shaft for reassembly. Remove cooling fan. Remove motor from motor mount.
6. Reassemble in reverse order and test for proper operation.

### MAIN FAN - REPLACEMENT

See "MOTOR, MAIN FAN" above.

### SWITCH, ON/OFF – SWITCH, STANDBY - REPLACEMENT

1. Shut off power at main breaker.
2. Remove control box top.
3. Depress clips on sides of switch and remove switch from front panel.
4. Disconnect all wires from switch. Mark all wires for reinstallation.
5. Reassemble in reverse order and check system operation.

### RELAY, TIME DELAY - REPLACEMENT

1. Shut off power at main breaker.
2. Remove rear cover.
3. Remove wires from time delay relay and mark wires for reinstallation.
4. Remove mounting screw and remove time delay relay.
5. Reassemble in reverse order and check system operation.

### RELAY, MAIN FAN - REPLACEMENT

1. Shut off power at main breaker.
2. Remove rear cover.
3. Remove wires from main fan relay and mark wires for reassembly.
4. Remove mounting screws and remove main fan relay.
5. Reassemble in reverse order and check system operation.

## **CIRCUIT BREAKER, MAIN MOTOR - REPLACEMENT**

1. Shut off power at main breaker.
2. Remove rear cover.
3. Remove wires from appropriate circuit breaker and mark wires for reassembly.
4. Remove mounting nut from circuit breaker and remove circuit breaker.
5. Reassemble in reverse order and check system operation. Be sure to reset circuit breaker before operation.

## **FUSE HOLDER - REPLACEMENT**

1. Shut off power at main breaker.
2. Remove rear cover.
3. Remove wires from appropriate fuse holder and mark wires for reassembly.
4. Remove mounting screws from fuse holder and remove fuse holder.
5. Reassemble in reverse order and check system operation.

## **RELAY, MAIN HEATER – RELAY, INFRARED HEATER - REPLACEMENT**

1. Shut off power at main breaker.
2. Remove rear cover.
3. Remove wires from appropriate heater relay and mark wires for reassembly.
4. Remove mounting screws from heater relay and remove heater relay.
5. Reassemble in reverse order and check system operation. Be sure to mount the heater relay in the upright position, mounting the relay upside down will cause the relay to be in the constant “on” position.

## **REVERSING SWITCH, CONVEYOR - REPLACEMENT**

1. Shut off power at main breaker.
2. Remove rear cover.
3. Remove wires from reversing switch and mark wires for reassembly.
4. Remove mounting nut from reversing switch and remove reversing switch.
5. Reassemble in reverse order and check system operation.

## **TRANSFORMER, CONTROL - REPLACEMENT**

1. Shut off power at main breaker.
2. Remove rear cover.
3. Remove wires from control transformer and mark wires for reassembly.
4. Remove mounting screws and remove control transformer.
5. Reassemble in reverse order and check system operation.

## **CAPACITOR, CONVEYOR MOTOR – REPLACEMENT**

1. Shut off power at main breaker.
2. Remove control box top. Remove tube from air pressure switch.
3. Remove wiring from air pressure switch and conveyor motor capacitor and mark all wires for reassembly.
4. Remove two screws and remove air pressure switch/capacitor mounting bracket.
5. Remove capacitor from mounting bracket.
6. Reassemble in reverse order and check system operation.

## **CONVEYOR MOTOR – REPLACEMENT**

1. Shut off power at main breaker.
2. Remove coupling from conveyor shaft (one screw at end of motor shaft).
3. Remove control box top and rear control box cover.
4. Remove three screws and remove main control board and mounting bracket.
5. Disconnect wiring for motor and remove motor mounting screws. Remove conveyor motor and mounting bracket.
6. Remove conveyor motor from mounting bracket.
7. Reassemble in reverse order and check system operation.

## **AIR PRESSURE SWITCH – REPLACEMENT**

1. Shut off power at main breaker.
2. Remove control box top. Remove tube from air pressure switch.
3. Remove wiring from air pressure switch and conveyor motor capacitor and mark all wiring for reassembly.
4. Remove two screws and remove air pressure switch/capacitor mounting bracket.
5. Remove air pressure switch from mounting bracket.
6. Reassemble in reverse order and check system operation.

## **AIR PRESSURE SWITCH – ADJUSTMENT**

1. Apply power to machine, set temperature control to maximum temperature.
2. Allow 30 minute preheat. Adjust air pressure switch so that switch will stay closed at maximum temperature.
3. Remove air tube from air pressure switch and verify that switch opens.
4. Reconnect air tube and check system operation.

## **THERMOCOUPLE – REPLACEMENT**

1. Shut off power at main breaker.
2. Remove control box top. Remove rear cover. Remove right side heating element cover.
3. Remove mounting screws and remove thermocouple from oven cavity.
4. Disconnect thermocouple from main control, remove thermocouple.
5. Remove connector plug from new thermocouple and mark wires for reassembly. Install thermocouple and reassemble plug connector.
6. Reassemble in reverse order and check system operation.

## **THERMOSTAT, HI-LIMIT – REPLACEMENT**

1. Shut off power at main breaker.
2. Remove rear cover, remove right side heating element cover.
3. Remove hi-limit thermostat from the mounting bracket. Remove mounting nut from hi-limit thermostat. Remove hi-limit thermostat.
4. Form 90° bend in hi-limit thermostat.
5. Reassemble in reverse order and check system operation. Be sure to reset thermostat before testing.

## **HEATING ELEMENT, MAIN – REPLACEMENT**

1. Shut off power at main breaker.
2. Remove conveyor, finger assemblies and plenum front. Remove rear cover and appropriate heating element cover.
3. Remove wires from heating element and mark wiring for reassembly.
4. Remove mounting screws and remove heating element.
5. Reassemble in reverse order and check system operation.

## **HEATING ELEMENT, INFRARED – REPLACEMENT**

1. Shut off power at main breaker.
2. Remove conveyor and lower finger assemblies. Remove front conveyor support from oven cavity.
3. Remove front cover and heating element cover. Disconnect wiring from heating element and mark wires for reassembly.
4. Reassemble in reverse order and check system operation.

## **MAIN CONTROL – REPLACEMENT**

1. Shut off power at main breaker.
2. Remove control box top, front panel and rear control box cover.
3. Remove display board from front panel by pulling board off of it's mounting pins.
4. Remove three screws from main control mounting bracket and remove main control board and its mounting bracket. Remove main control from it's mounting bracket by pulling the control from the mounting bracket.
5. When installing new control, be sure to use ground strap so that there is no static electricity. When installing new control, be sure to set the jumpers on the control for proper voltage (120/240) and frequency (50Hz./60Hz.). After the new control is installed, the control will need to be initialized. To initialize the new control, press and hold the two center buttons on the front control panel. After the oven starts, release the buttons, the control is now initialized. Reassemble in reverse order and check system operation.



GENERAL VIEW  
MODEL 1921, 1922

A	370438	Finger housing, lower
B	370441	Columnating plate, lower
C	370443	Finger cover, lower left. Marked 'LS'
D	370444	Finger cover, lower right. Marked 'RS'
E	370445	Front element cover
F	370446	Front cover
G	370447	Finger cover, upper
H	370442	Columnating plate, upper
I	370439	Finger housing, upper
J	370448	Air wash panel, upper
K	370449	Air wash panel, lower
L	370450	¼ turn fastener
M	370451	Air return assy.
N	370452	Finger support, upper
O	370454	Plenum front
P	370453	Finger support, lower
Q	370455	Top
R	369373	Receptacle, ¼ turn fastener

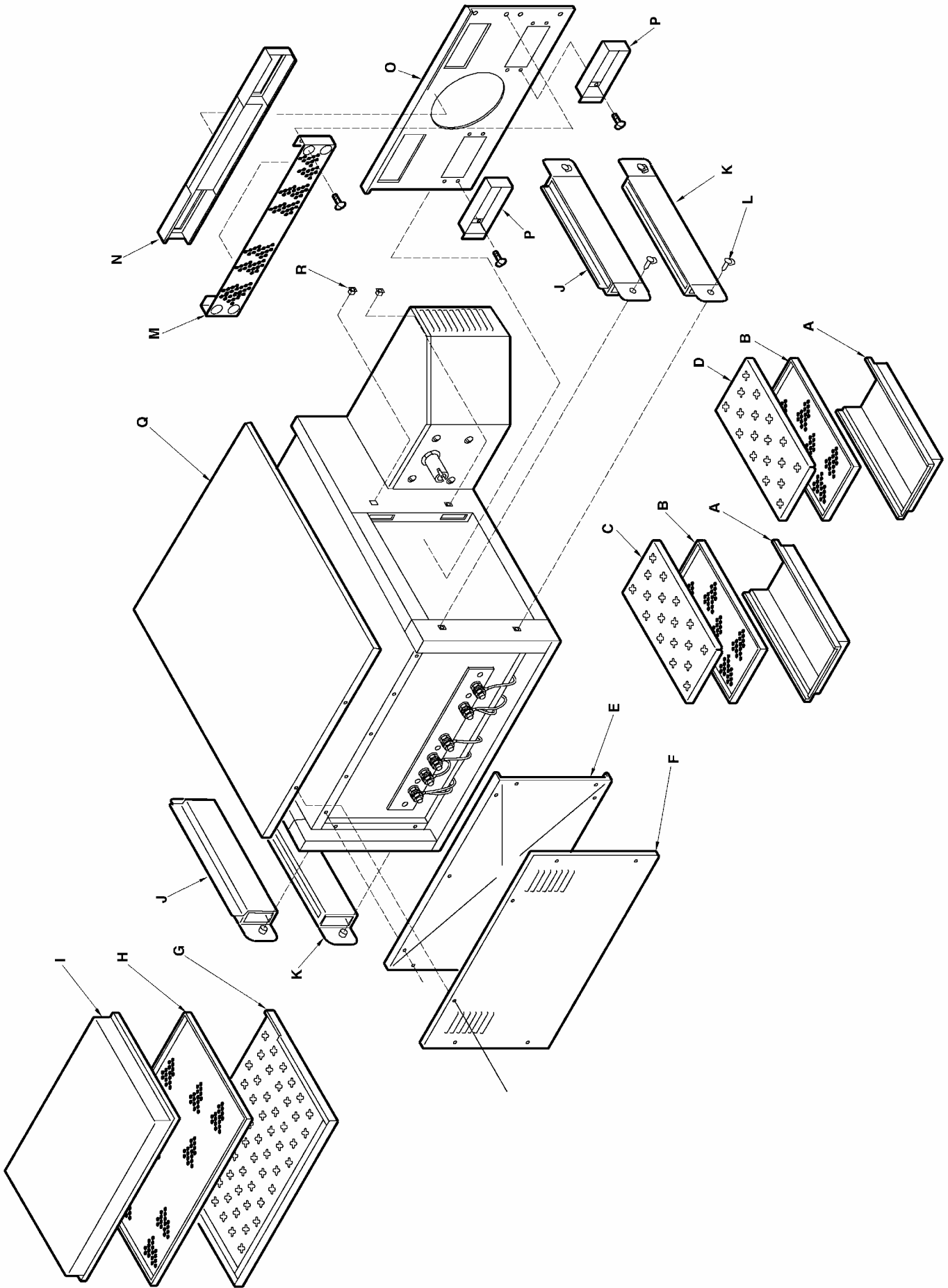

CONTROL BOX VIEW  
MODEL 1921, 1922

A	369432	Switch, on/off
B	370456	Label, control panel
C	370457	Front panel
D	369460	Spring, compression
E	369413	Drive key
F	369410	Coupling sleeve
G	370106	Washer
H	350259	Screw
I	370458	Heating element, Infrared – 208VAC
	370460	Heating element, Infrared – 240VAC
J	370462	Motor, conveyor
K	370383	Capacitor, conveyor motor
L	369430	Air pressure switch
M	370463	Top, control box
N	370464	Control, main and display
O	370465	Cover, rear control box



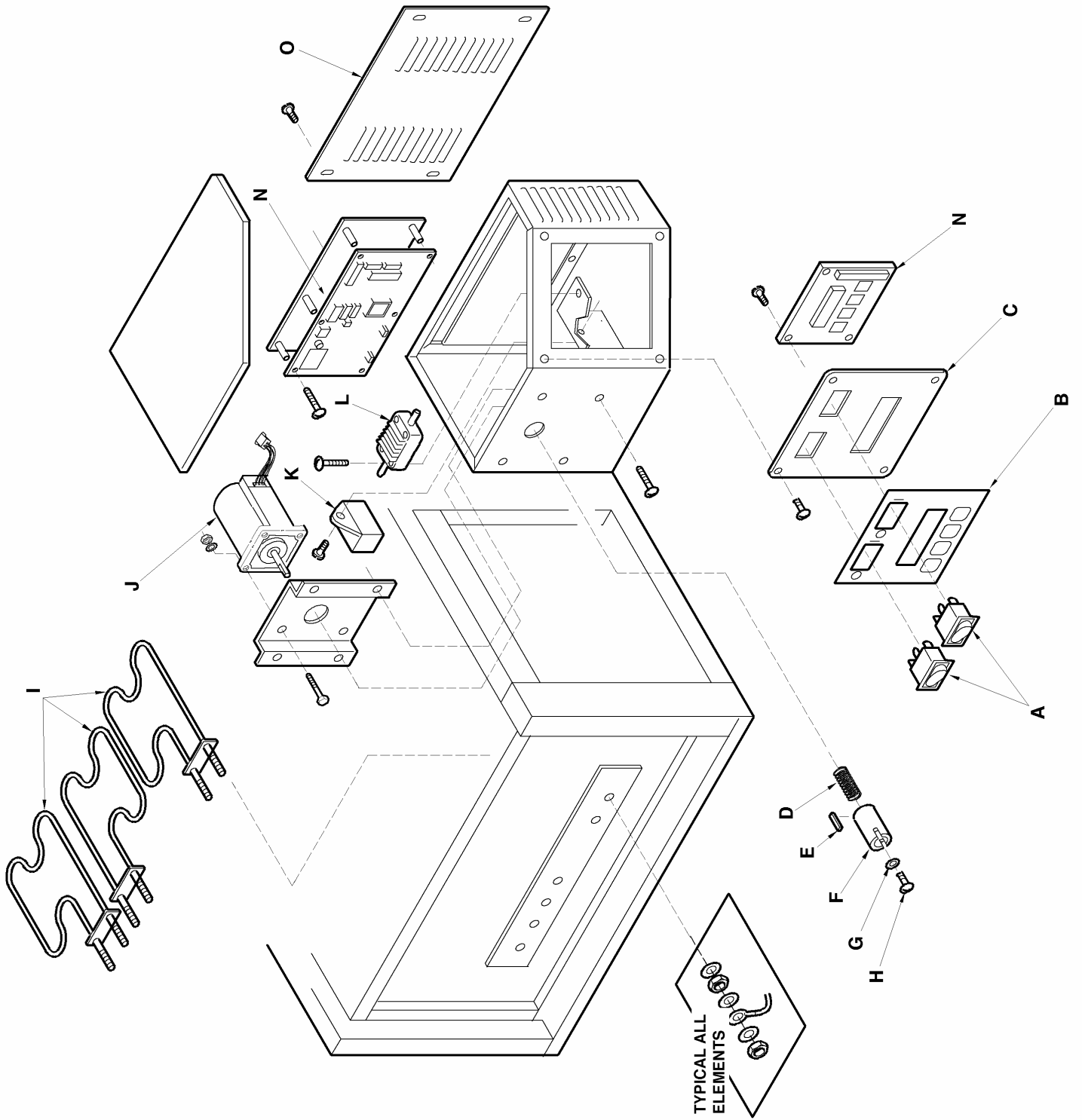

REAR VIEW  
MODEL 1921, 1922

A	370466	Timer, cool down, 30 minute
B	369422	Relay, main fan
C	370467	Thermocouple
D	370468	Cover, heating element
E	370469	Motor mount
F	370470	Motor, main fan
G	370468	Cover, heating element
H	370471	Cooling fan
I	370472	Air switch tube assy.
J	369427	Transformer, control
K	370459	Heating element, 208VAC
	370461	Heating element, 240VAC
L	369479	Relay, Heating element
M	369409	Main fan
N	370473	Circuit breaker, 3A
O	357067	Thermostat, hi-limit
P	370359	Reversing switch, conveyer
Q	369166	Fuse, 10A
R	369129	Fuse holder
S	12682	Adapter, cable
T	370474	Power cord
U	370475	Cover, rear
Not shown	370476	Transformer, motor (Model 1922 only)

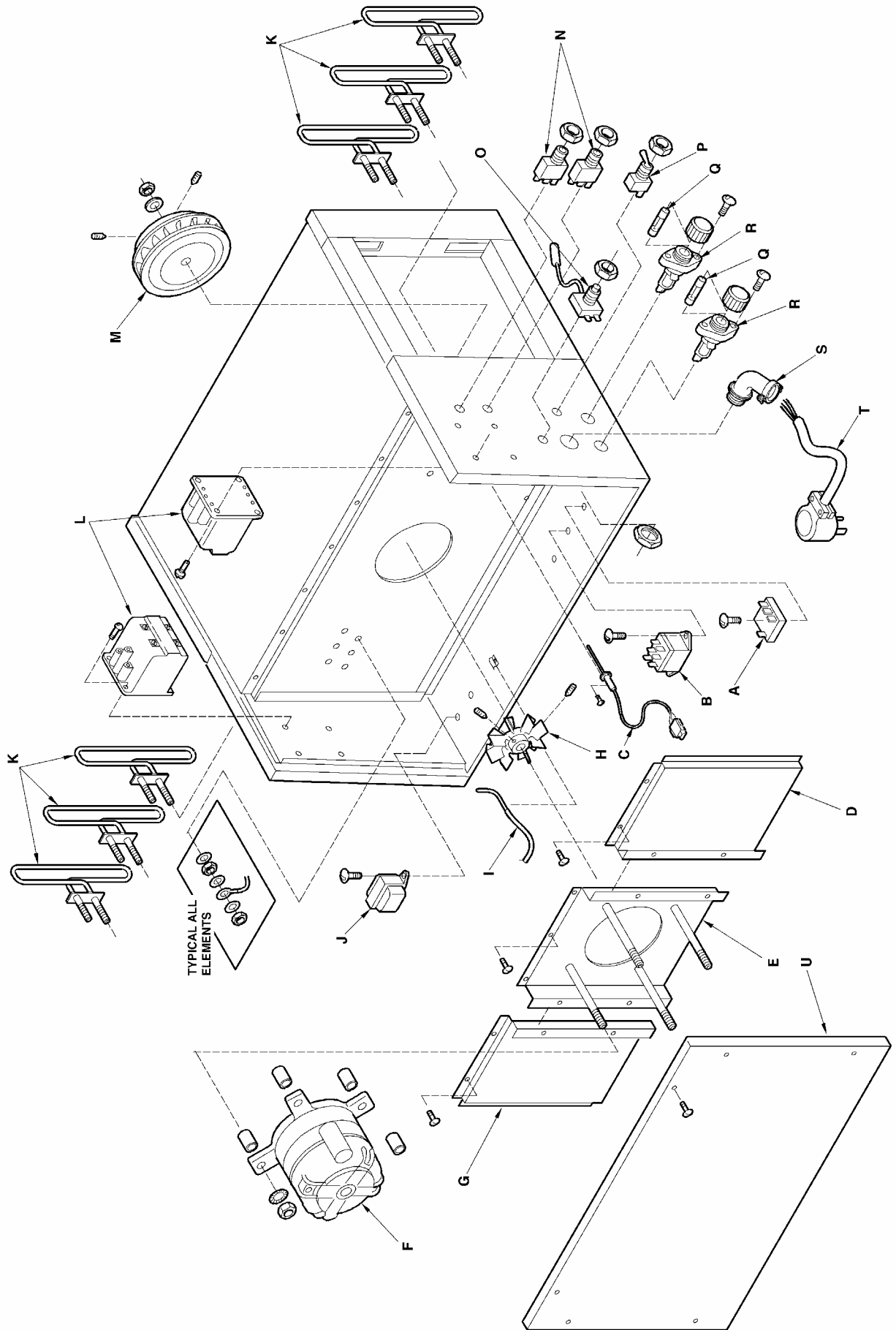

CONVEYOR  
MODEL 1921, 1922

A	370477	Crumb pan, right
B	370478	Crumb pan, left
C	370440	Frame, conveyor
D	370479	Belt, conveyor
E	370480	Bracket, conveyor bearing
F	370481	Flanged bearing, conveyor
G	370482	Shaft, idler
H	369515	Drive sprocket
I	369952	Connecting link, conveyor (three required)
J	370483	Shaft, drive
K	369471	Pin
Not shown	370484	Conveyor assembly, complete

