



# INSTRUCTIONS

-J04467

REV. 2007-06-28

## ISOLATED DRIVE SYSTEM

### GENERAL

#### Kit Number

40287-07

#### Models

For model fitment information, please see the P&A Retail Catalog or the Parts and Accessories section of [www.harley-davidson.com](http://www.harley-davidson.com) (English only).

#### Additional Parts Required

Separate purchase and installation of additional parts or accessories may be required for proper installation of this kit on your model motorcycle. Please see the P&A Retail Catalog or the Parts and Accessories section of [www.harley-davidson.com](http://www.harley-davidson.com) (English only) for a list of required parts or accessories for your model.

### ⚠ WARNING

The rider's safety depends upon the correct installation of this kit. Use the appropriate service manual procedures. If the procedure is not within your capabilities or you do not have the correct tools, have a Harley-Davidson dealer perform the installation. Improper installation of this kit could result in death or serious injury. (00333a)

#### NOTE

This instruction sheet references Service Manual information. A Service Manual for your model motorcycle is required for this installation and is available from a Harley-Davidson Dealer.

#### Kit Contents

See Figure 7 and Table 1.

### REMOVAL

### ⚠ WARNING

To prevent accidental vehicle start-up, which could cause death or serious injury, disconnect negative (-) battery cable before proceeding. (00048a)

### ⚠ WARNING

To prevent accidental vehicle start-up, which could cause death or serious injury, remove maxi-fuse before proceeding. (00251a)

1. Disconnect the negative (-) battery cable or remove the Maxi<sup>®</sup> fuse.
2. Refer to an appropriate Service Manual and remove the rear wheel from the motorcycle.

### INSTALLATION

#### Prepare Wheel

1. Remove five screws and the stock final drive sprocket from the rear wheel.
2. Remove any remaining lock patch material from the threaded final drive sprocket holes using a nylon brush and hot, soapy water. Do **not** use a wire brush.
3. Check the depth of the final drive sprocket holes of the rear wheel.
  - a. Thread gauge screw into each final drive sprocket hole of the rear wheel to verify that all of the holes are deep enough. The head of the gauge bolt must bottom against the wheel.
  - b. If the head of the gauge screw does not bottom out against the wheel, tap the hole through to the inner pocket of the wheel with a 7/16-14 inch tap. Repeat for each hole, then verify the hole depth again using the gauge screw.
  - c. If the head of the gauge screw does bottom out against the wheel, proceed to the "Assemble and Install Compensator" section of this Instruction Sheet.

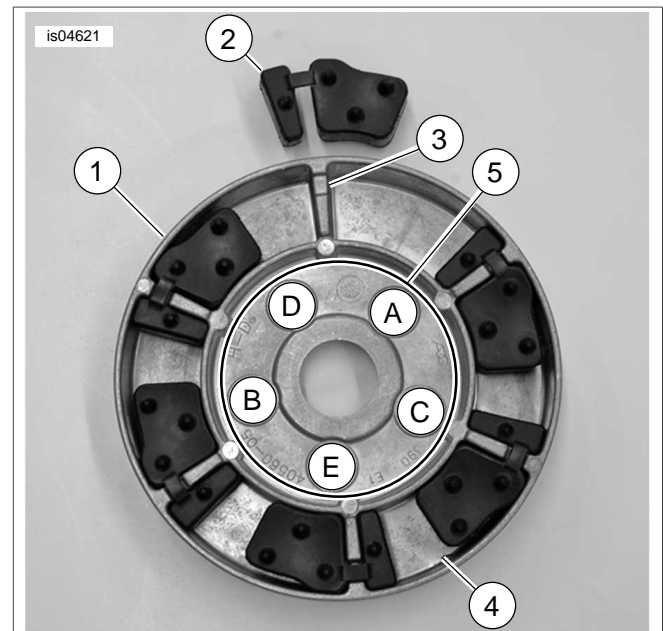

1. Compensator bowl
2. Isolator
3. Rib slot
4. Gap
5. Torque pattern

Figure 1. Install Isolators in Compensator Bowl

## Assemble and Install Compensator

1. Follow the instructions for Bearing Installation in the BEARING REPLACEMENT section of this Instruction Sheet and press the bearing into the sprocket.
2. See Figure 1. Install six isolators into the compensator bowl as follows:
  - a. Lubricate each isolator with 50/50 mix of isopropyl alcohol and water. Do **not** use a petroleum based lubricant.
  - b. Push each isolator into bowl, so that strap engages slot in rib.
  - c. Verify that each isolator (2) bottoms in bowl (1) and that each segment is square and flush against side walls of rib (3).
3. With the concave side out, align holes in bowl with those in wheel hub and start five hex screws (with captive washers).
4. See Figure 1. Alternately tighten screws according to the torque pattern (5) shown to 65 ft-lbs (88 Nm).
5. See Figure 7. Place the inner spacer (thick) (5) from the kit into compensator bowl bore.
6. Using a 50/50 mix of isopropyl alcohol and water, lubricate sides of each isolator where contact occurs with sprocket lugs.
7. See Figure 1. Aligning lugs on inboard side of sprocket with gaps (4) between isolators, push sprocket onto bowl. Ensure that the lugs of the sprocket seat properly and fully between the isolators in the compensator bowl.
8. Refer to the appropriate Service Manual and install the rear wheel assembly with the following exceptions:
  - a. See Figure 7. Install the outer (thin) spacer (6) when installing the wheel assembly.
  - b. Tighten the axle nut to specification, then loosen and tighten to specification again. Verify that the tip of the bowl does not contact the sprocket inside face. A small gap should be seen.
9. Refer to the appropriate Service Manual and install the Maxi fuse or connect the negative (-) battery cable.

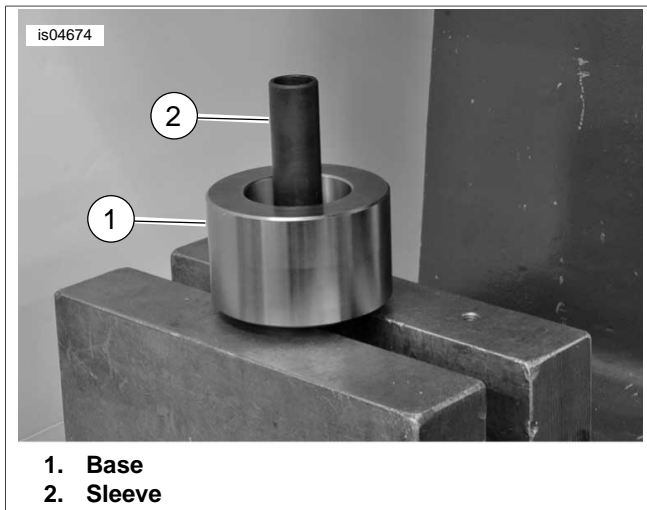

Figure 2. Rear Wheel Compensator Sprocket Bearing Remover/Installer (HD-48921)

## BEARING REPLACEMENT

### Bearing Removal (If Necessary)

1. Refer to the appropriate Service Manual and remove rear wheel.
2. Pull the sprocket from the compensator bowl.
3. See Figure 2. Obtain the REAR WHEEL COMPENSATOR SPROCKET BEARING REMOVER/INSTALLER (HD-48921).
4. See Figure 3. Place parallel press blocks on the deck of an arbor press. Leave a gap between press blocks to accommodate base pin in next step.
5. Position base (1) on press blocks with the large OD top-side.
6. Slide sleeve over base pin.
7. See Figure 4. With the inboard side facing up, slide sprocket (1) over the sleeve until it rests on base.
8. Slide small OD of driver (3) over sleeve until contact is made with the inner race of bearing.
9. Center driver under ram and apply pressure until bearing drops into base. Disassemble tool and discard bearing.



1. Base
2. Sleeve

**Figure 3. Base and Sleeve Set for Bearing Removal**

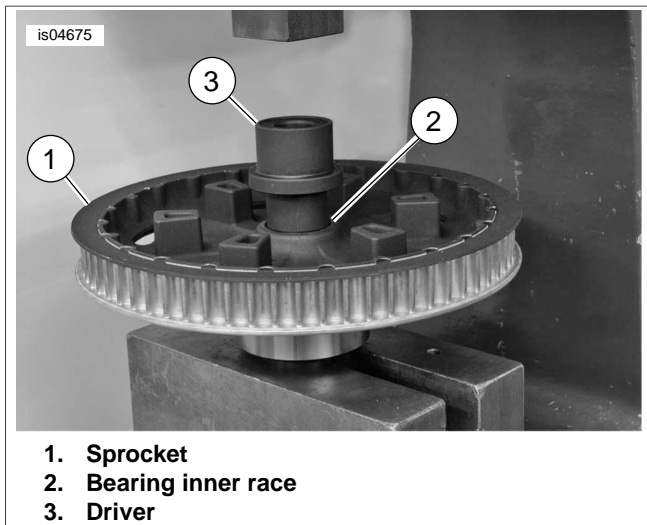

1. Sprocket
2. Bearing inner race
3. Driver

**Figure 4. Remove Compensator Sprocket Bearing**

### Bearing Installation

1. See Figure 2. Obtain the REAR WHEEL COMPENSATOR SPROCKET BEARING REMOVER/INSTALLER (HD-48921).
2. See Figure 5. Position base (1) on deck of arbor press with the small OD topside.
3. Slide sleeve (2) over base pin.
4. Verify that sprocket bearing bore is clean and dry.
5. See Figure 6. With the outboard side facing up, slide sprocket over sleeve until it rests on the base.

6. Slide new bearing (2) over sleeve and center the bearing on the sprocket bore chamfer.
7. Slide large OD of driver (3) over sleeve until contact is made with outer race of bearing.
8. Center driver under ram and apply pressure until bearing makes firm contact with counterbore in sprocket.
9. Turn sprocket over and verify that bearing is fully seated.
10. Refer to the ASSEMBLE AND INSTALL COMPENSATOR section of this Instruction Sheet and assemble the final drive sprocket to the compensator bowl.
11. Refer to the appropriate Service Manual and install the rear wheel.

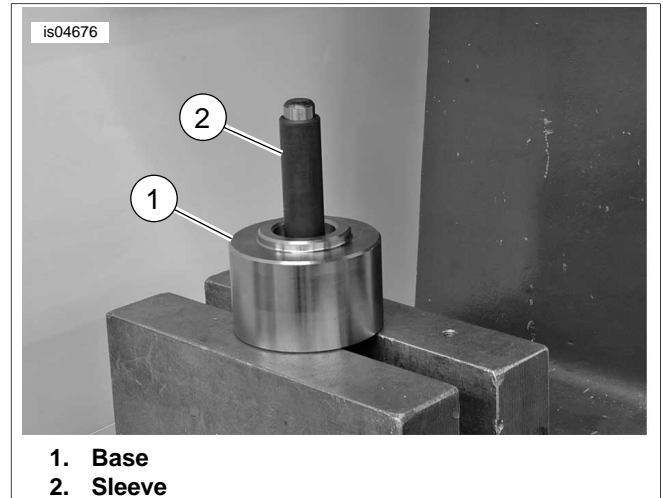

1. Base
2. Sleeve

**Figure 5. Base and Sleeve Set for Bearing Installation**

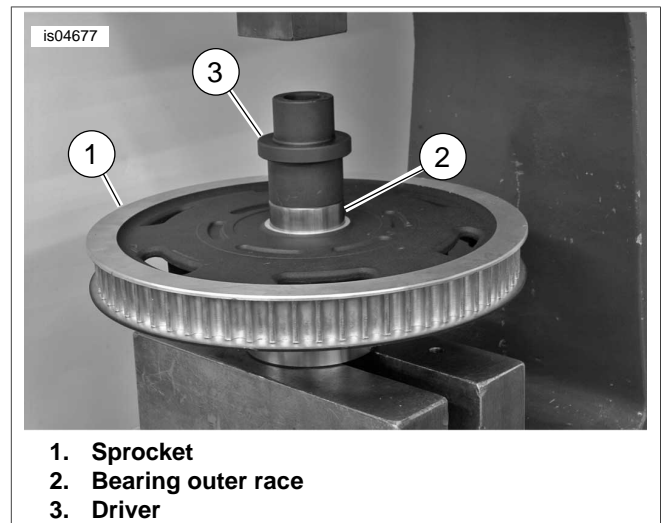

1. Sprocket
2. Bearing outer race
3. Driver

**Figure 6. Install Compensator Sprocket Bearing**

## SERVICE PARTS

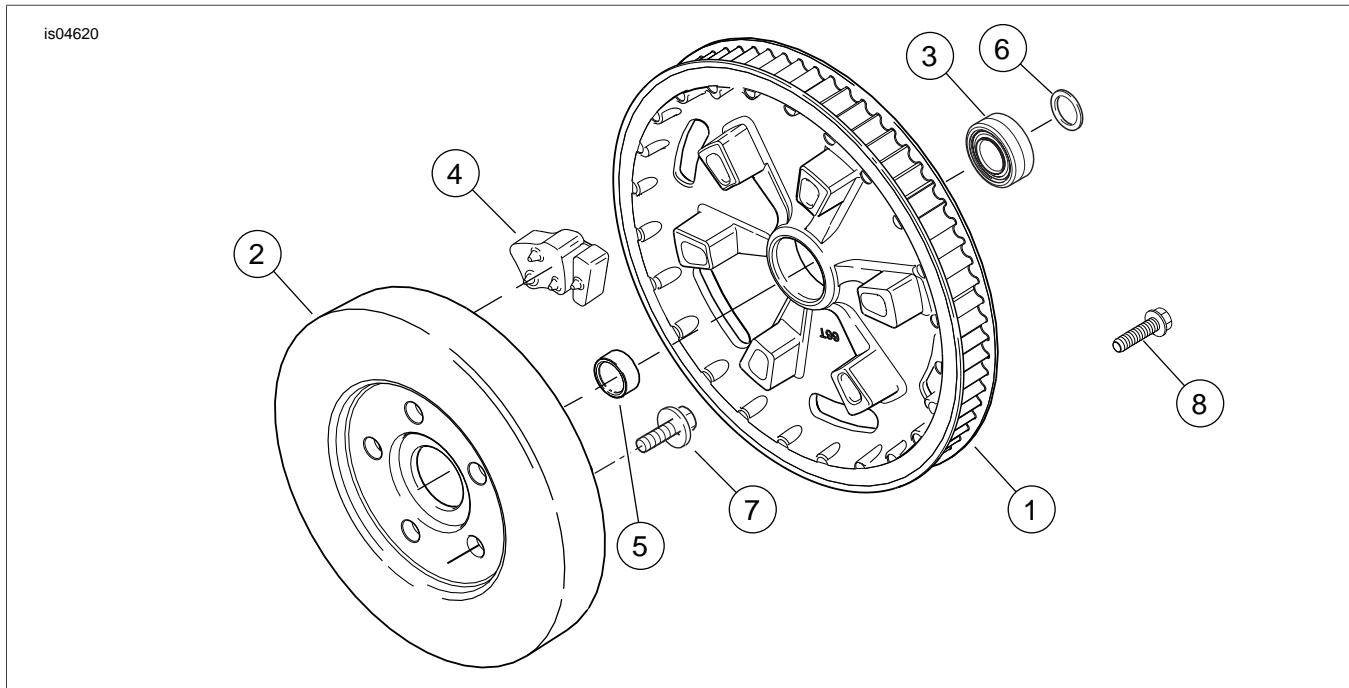

Figure 7. Service Parts: Touring Rear Sprocket Compensator Kit (40287-07)

Table 1. Service Parts

Item	Description (Quantity)	Part Number
1	Sprocket, final drive (black)	40265-08
2	Bowl	40560-05
3	Bearing	40670-06
4	Isolator, rubber	40278-08
5	Spacer, inner	11846
6	Spacer, outer	11844
7	Hex screw with washer (5)	3814
8	Gauge screw, 7/16-14 x 1-1/2	Not Sold Separately