

---

# AES•7750-*F*

---

*Including 7750-F-4x4 and 7750-F-8*  
**RF Subscriber Unit Version 2**  
**INSTALLATION & OPERATION MANUAL**

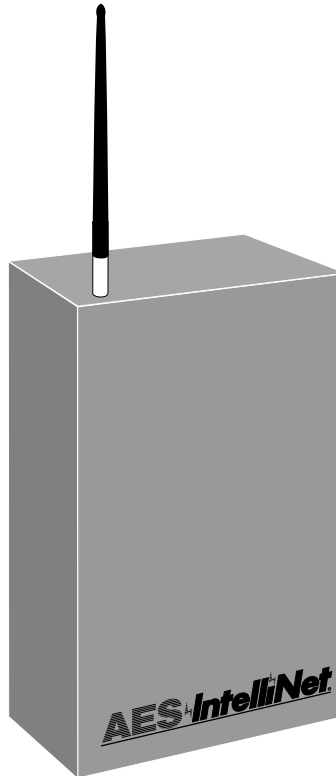

1 1 1 0 0 3

**AES IntelliNet**<sup>®</sup>

**AES Corporation**

285 Newbury Street • Peabody, Massachusetts 01960-1315 USA

Tel 978-535-7310 • Fax 978-535-7313

Copyright 2000 All Rights Reserved

# Table of Contents

**Wiring and Parts Location Diagrams .....3**

**Commercial Fire Alarm Installation and UL Compliance .....4**  
 General Requirements .....4  
 UL Burglary .....5  
 Compliance Chart ..... 6,7  
 Fire Application; Canadian Installations ..... 8

**Physical Installation .....9**

**Power Up, Initial Programming ..... 10**

**Error Messages, Troubleshooting ..... 11**

**Status Indicators ..... 11**

**Programming the Unit ..... 12**  
 Overview ..... 12  
 Setup Unit ..... 13  
 ID #; Dealer Code; Enable Repeating  
 Set Check-In Time ..... 14  
 Zone Trigger Programming ..... 15  
 Zone Trigger Wiring Diagrams ..... 18  
 Supervised / Fire - EOL; Reversing Polarity

**Initializing the Unit ..... 20**

**Status Check ..... 21**

**Other Functions ..... 22**  
 Default Reset  
 Monitoring Modes  
 Key Transmitter  
 Sending/Receiver ASCII Text Messages  
 Enable/Disable Repeating  
 Time-to-Live Programming

**Programming the Subscriber from a PC ..... 26**

**Antenna Cut / Acknowledge Delay Output ..... 26**

**7750-F Specifications, FCC Compliance ..... 27**

**Warranty / Service Procedures ..... 28**

**Quick Programming Guide ..... 29**

Copyright 2000, 2001, 2003 • AES Corporation • All Rights Reserved  
 AES•IntelliNet is a Registered Trademark of AES Corporation

## Model Number 7750-*F-8 Series* Subscriber Unit

Electrical Rating: 12VDC nominal

|                             |                |                 |
|-----------------------------|----------------|-----------------|
| <b>Current Draw:</b>        | <b>Standby</b> | <b>Transmit</b> |
| Subscriber Unit Only        | 584ma          | 1.55A           |
| Subscriber Unit & 7068 'Tap | 660ma          | 2.00A           |

Onboard Fuse: Self Resetting / Not User Serviceable

**In-Line Battery Fuse: 3 Ampere**

**12V Rechargeable Battery\*: 7AH (24 Hr); 14AH (60 Hr)**

\*If battery(s) are housed in separate enclosure see page 8.

Low battery condition is reported to the central station.

**All Circuits Power Limited.**

## Model Number 7750-*F-4X4 Series* Subscriber Unit

Electrical Rating: 12VDC nominal

|                             |                |                 |
|-----------------------------|----------------|-----------------|
| <b>Current Draw:</b>        | <b>Standby</b> | <b>Transmit</b> |
| Subscriber Unit Only        | 230ma          | 1.2A            |
| Subscriber Unit & 7068 'Tap | 295ma          | 1.3A            |

Onboard Fuse: Self Resetting / Not User Serviceable

**In-Line Battery Fuse: 3 Ampere**

**12V Rechargeable Battery\*: 7AH (24 Hr); 14AH (60 Hr)**

\*If battery(s) are housed in separate enclosure see page 8.

Low battery condition is reported to the central station.

**All Circuits Power Limited.**

# Wiring and Parts Location Diagram

## AES 7750-*F* Series Radio Subscriber Unit

**WARNING:** For Continued Protection Against Fire, Replace Only With Same Type and Rating of Fuse

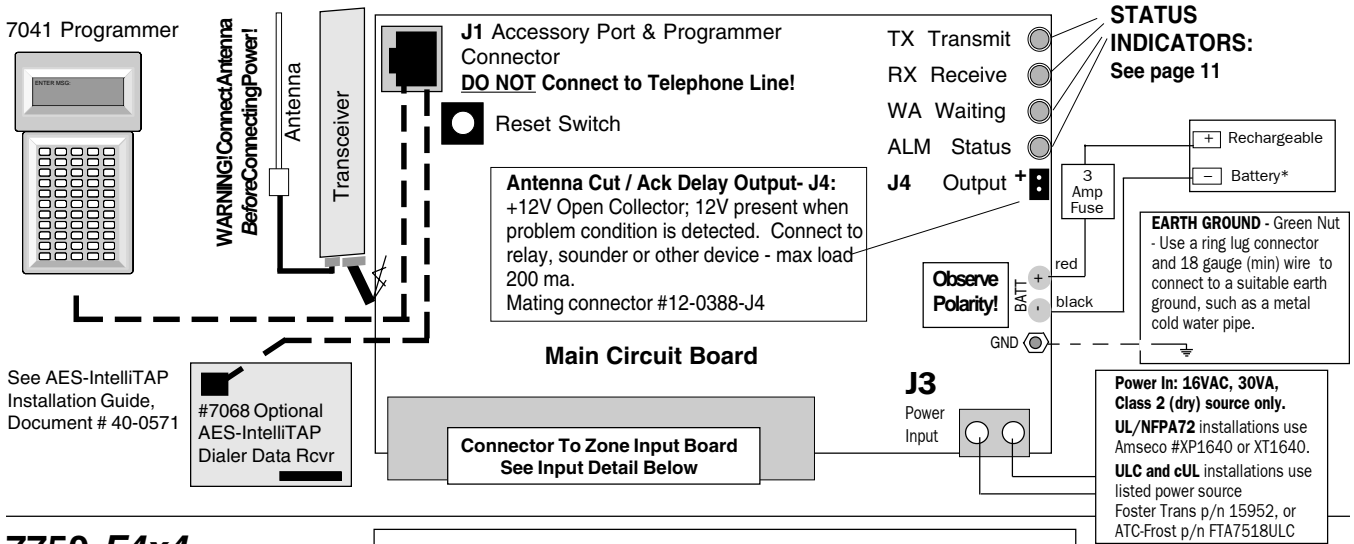

## 7750-*F4x4* Zone Inputs

### 7750-*F4x4* Zones 1 - 4

Typical Input: Dry Contact  
EOL Programmable Options:  
Supervised, Fire, Bypass; Restorals  
Shown Wired for Fire / EOL:  
1K resistor = Normal / Close = Alarm / Open=Trouble!<sup>1</sup>K  
Max Line Impedance = 100 ohms plus EOL resistor.

**Power must be provided to input board for Zones 1 - 4.** Requires 8-28VDC to terminals (J4) at center of input board. Internal battery may be used, but earth ground will be tied to common terminals. This may affect connection to other panels. If earth ground cannot be used, supply the input board with power from the alarm panel.

**Zones 1-4, To monitor power on Input Board when powered by an alarm panel:** For all Commercial Fire, UL burglar and Canadian UL burglar alarm installations, use one of the Z5-Z8 as a power fail report. Bridge power to one of the Z5-Z8 inputs. Program the zone for "F". If power fails, the zone reports "Trouble". Flag this at the central station in automation software as a power fail.

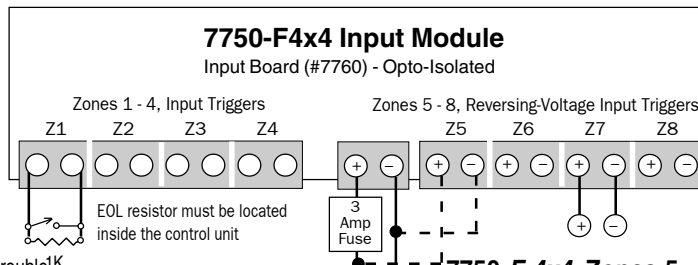

### 7750-*F4x4*, Zones 5 - 8, Reversing-Voltage Input from Fire Panel,

- **Input Range: 10 to 30VDC filtered;**  
+/- Voltage as Shown = Normal  
-/+ Reversed Voltage = Alarm  
Low / No Voltage = Trouble
- Intended for Connection to a Polarity Reversal Circuit of a Control Unit having Compatible Ratings (example on zone 7).
- Also used to monitor power when a remote source is used to power isolated zones 1-4 (example on zone 5).
- Current Draw for Zones 5-8, at 10V=2.5 ma; at 30V=10 ma.
- The Reversing Voltage inputs are self powered.
- Program unused inputs for BYPASS, otherwise unused inputs report as "trouble".

## 7750-*F8* Zone Inputs

**Power must be provided to 7761 "F-8" input board.** Requires 8-28VDC to terminals (J3) at lower left of input board. Internal battery may be used, but earth ground will be tied to common terminals. This may affect connection to other panels. If earth ground cannot be used, supply the input board with power from the alarm panel.

**To monitor power on Input Board when powered by an alarm panel:** For all Commercial Fire, UL burglar and Canadian UL burglar alarm installations, use one of the zones as a power fail report. Install a 3.01K resistor on the designated zone terminals. Program the zone for F / Fire. When power to the input board is lost, zone will report a "Trouble". Flag this as a power failure at the central station / automation software.

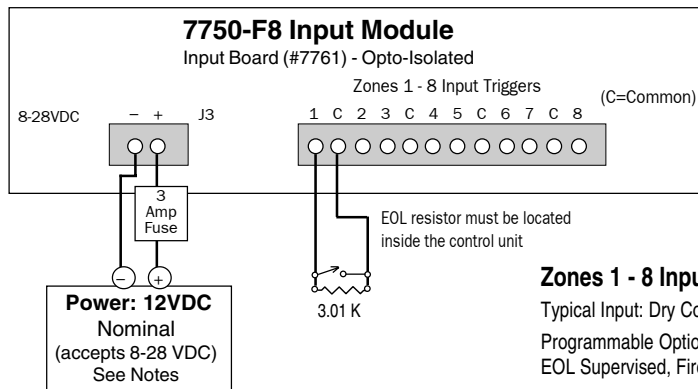

### Zones 1 - 8 Input Triggers

Typical Input: Dry Contact  
Programmable Options:  
EOL Supervised, Fire, Bypass; Restorals  
Shown Wired for Fire / EOL:  
3.01K resistor = Normal / Close = Alarm / Open=Trouble.  
Max Line Impedance = 300 ohms plus EOL resistor.

## Commercial Fire Alarm Installation and UL Compliance

**UL Burglar Installations Tamper Protection:** A UL Listed tamper switch that protects the cover against removal is required on the 7750-F. Additionally, when the 7750-F is used on a Safe or Vault UL burglar alarm installation, a rear pry-off tamper and a shock sensor UL Listed for protection of sheet metal enclosures is also required to be mounted on the inside of the 7750-F unit.

**Canadian Burglar Alarm Installations:** A tamper switch listed for use in Canada is required for protection of the 7750-F's cover. Additionally, when the 7750-F is used on a Safe or Vault burglar alarm installation in Canada, a rear pry-off tamper and a shock sensor Listed for protection of sheet metal enclosures is also required to be mounted on the inside of the 7750-F unit. The rear pry-off tamper and shock sensor must be Listed for use in Canada.

**Power Requirements:** 16 VAC, 30VA;

- For UL certificated burglar installations, use the Listed AMSECO transformer p/n XP-1640 or XT-1640,
- For commercial fire alarm installations in the U.S., use the Listed AMSECO transformer p/n XP-1640 or XT-1640.
- For commercial fire alarm installations in Canada, use the Listed Foster Model 15952 transformer or ATC-Frost model FTA7518ULC.
- Do Not Connect To A Receptacle Controlled By A Switch

### Back Up Battery Requirement, Commercial Fire

- Central Station Fire Signalling (24hr): use a 12V, 7 AH battery
- Remote Station Fire Signalling (60hr): use a 12V, 14 AH battery pack (see page 8)

### UL 681, CAN/ULC-304-M88 and CAN/ULC-S303-M91:

- Commercial Burglar Alarm Installation (4hr) use 12V, 7 AH battery
- Replace battery(s) every 3 years

**7750-F EOL Inputs / Zones:** EOL Alarm Inputs must be programmed for Supervised or Fire.

• **Type of signaling service;** manual fire alarm, automatic fire alarm, sprinkler supervisory and water flow alarm.

• **For a UL and ULC certificated system,** maintenance contracts must be in force between the central station issuing the certificate and the subscriber with the certificated system.

• **For Central Station Burglar Alarm Systems that Require Two Methods of Signal Transmission** (see chart pg 6) - connect the J4 output of the 7750-F Subscriber Unit main circuit board (see page 3) to a relay module that will cause the alarm panel to generate a local audible and visual annunciation when the antenna is cut.

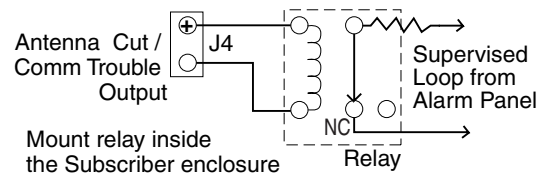

- For U.S. fire alarm installations, the relay module must be UL Listed for commercial fire alarm service.
- For Canadian fire alarm installations, the relay module must be Listed for commercial fire alarm service in Canada.
- For UL burglar alarm installations the relay module must be UL Listed for commercial burglar alarm service.
- For commercial burglar alarm installations in Canada the relay module must be Listed for commercial burglar alarm use in Canada.

When used for fire or burglar alarm installations, the relay module must be located inside the 7750-F subscriber unit. The wire connections between the control panel and the relay module must be supervised against opens, shorts and grounds.

• **For UL Grade A and AA Central Station Burglar Alarm** Installations, the 7750-F subscriber unit shall be connected to a UL Listed central station control panel such that:

- a) Opening and closings signals are provided.
- b) A means is provided for the central station operator to signal the subscriber that a normal closing signal has been received (i.e. a ringback signal).
- c) The control panel and the AES radio Subscriber Unit must monitor each other's method of signal transmission. The operable method of signal transmission shall send a signal to the central station if the other method of signal transmission is unable to transmit. The signal shall identify the condition.
- d) The time lapse between the occurrence of the above, such as the removal of the antenna, that can prevent the receipt of signals from the protection system and the annunciation and recording of that condition at the central station shall not exceed 200 seconds.
- e) The time lapse between the occurrence of a status change in a protection system and the annunciation and recording of that change at the central station shall not exceed 90 seconds.
- f) The cover to the 7750-F is protected with a UL Listed tamper switch.

• **For UL Grade B and BB Central Station Burglar Alarm** Installations, the 7750-F subscriber unit shall be connected to a UL Listed central station control panel such that:

- a) Opening and closings signals are provided.
- c) The control panel and the AES radio Subscriber Unit must monitor each other's method of signal transmission. The operable method of signal transmission shall send a signal to the central station if the other method of signal transmission is unable to transmit. The signal shall identify the condition.
- d) The time lapse between the occurrence of the above, such as the removal of the antenna, that can prevent the receipt of signals from the protection system and the annunciation and recording of that condition at the central station shall not exceed 200 seconds.
- e) The time lapse between the occurrence of a status change in a protection system and the annunciation and recording of that change at the central station shall not exceed 90 seconds.
- f) The cover to the 7750-F is protected with a UL Listed tamper switch.

• **For UL Grade A and AA Police Station Connected Burglar Alarm** Installations, the 7750-F subscriber unit shall be connected to a UL Listed central station control panel such that:

- a) The time lapse between the occurrence of a status change in a protection system and the annunciation and recording of that change at the central station shall not exceed 90 seconds.
- b) The control panel is connected in conduit to a UL Listed burglar alarm sounding device. Depending upon the particular installation an alarm sounding device housing may also be required.
- c) A bell test on arming is also provided.

• **For UL Grade C and CC Central Station Burglar Alarm** Installations, the 7750-F subscriber unit shall be connected to a UL Listed central station control panel such that:

- a) The control panel and the AES radio Subscriber Unit must monitor each other's method of signal transmission. The operable method of signal transmission shall send a signal to the central station if the other method of signal transmission is unable to transmit. The signal shall identify the condition.
- b) The time lapse between the occurrence of the above, such as the removal of the antenna, that can prevent the receipt of signals from the protection system and the annunciation and recording of that condition at the central station shall not exceed 200 seconds.
- c) The time lapse between the occurrence of a status change in a protection system and the annunciation and recording of that change at the central station shall not exceed 90 seconds.

**For Safe and Vault Burglar Alarm** Installations for any Grade, the 7750-F must also be protected with a UL Listed rear pry-off tamper and a shock sensor Listed for the protection of sheet metal enclosures.

# Compliance Chart - AES 7750-F SUBSCRIBER UNIT

For All Commercial Fire Alarm Installations (NFPA72), UL Commercial Burglar Alarm Installations (UL 681 \* 827), and Commercial Burglar Alarm installations in Canada CAN/ULC-S304-M88 & CAN/ULC-S303-M91.

UL 864 / NFPA-72 Standard for Control Units for Fire Protective Signaling Systems (UOJZ and UOXX, UOJZ when installed as part of the AES-IntelliNet Receiving System and UOXX when used as an accessory unit with other Listed Receiving System equipment. Includes 4, 5, 6 and 7.

UL 1610, Standard for Central Station Burglar Alarm Units (AMCX).

UL 365, Standard for Police Station connected Burglar Alarm Units and Systems (APAW).

UL 609, Standard for Local Burglar Alarm Units (AOTX) when remote signaling is required.

UL 1076, Standard for Proprietary Burglar Alarm Units and Systems

|   | Battery Requirement 4/24/60 | Accessory Battery Case Req. | Tamper Protection - Case | Supervision -Inputs | Req'd # Paths to Central | Check-In Interval (#/See Notes)                      | Shock Sensor Required | Rear Pry Off Sensor Required | More Than One Method of Signal Transmission Req (ie DACT, Der Ch, Mpx Line) |
|---|-----------------------------|-----------------------------|--------------------------|---------------------|--------------------------|--|-----------------------|------------------------------|---|
| A) Proprietary Fire<br>(UL 864 / NFPA72, UOJZ, UOJZ7, IPXX7)                                    | 24                          | No                          | No                       | Yes                 | T6-2<br>T7-2             | 24 hr<br>24 hr                                       | No                    | No                           | No  |
| B) Central Station Fire<br>(UL 864 / NFPA72, UOJZ, UOJZ7, IPXX7)                                | 24                          | No                          | No                       | Yes                 | T6-2<br>T7-2             | 24 hr<br>24 hr                                       | No                    | No                           | No  |
| C) Remote Station Fire<br>UOJZ, UOJZ7, UOXX, UOXX7)   | 60                          | Yes                         | No                       | Yes                 | T6-2<br>T7-2             | 24 hr<br>24 hr                                       | No                    | No                           | No  |
| Central Station Burglar Alarm<br>(UL 1610, CAN/ULC-S304-M88, AMCX, AMCX7)                       | 4                           | No (opt)                    | Yes                      | Yes                 | 1                        | AA-(1,2)<br>A(2,3) B(3)<br>BB (1)<br>C (3)<br>CC (1) | On S+V only (5)       | On S+V only (5)              | Yes<br>No, No<br>Yes<br>No<br>Yes   |
| Police Station Connected Burglar Alarm<br>(UL 365, CAN/ULC-S303-M91, CAN/ULC-S301-M88)          | 4                           | No (opt)                    | Yes                      | Yes                 | 1                        | AA (1)<br>A (3,5)                                    | On S+V (5)            | On S+V (5)                   | Yes<br>No   |
| Local Burglar Alarm - when remote monitoring is required (UL609, CAN/ULS-S303-M91, AOTX, AOTX7) | 4                           | No (opt)                    | Yes                      | Yes                 | 1                        | A (4,5)  | A(4)                  | A(4)                         | Opt   |
| Type 6 Fire   | 24 or 60                    | Yes for 60                  | No                       | Yes                 | 2                        | 24 hr  | NA                    | NA                           | No  |
| Type 7 Fire   | 24 or 60                    | Yes for 60                  | No                       | Yes                 | 2                        | 24 hr  | NA                    | NA                           | No  |

Type 4, 5 Fire Available; Contact AES for details

See Notes, next page

**FOOTNOTES for Compliance Chart on page 6:**

1. Since opening/closing and ringback signals are provided by a second communications method (DACT), the minimum check in time for Grade AA, BB, or CC Central Station Burglar Alarm installation is a least once every 6 minutes.
2. Check-in signals do not apply to Grade A.
3. Grade B and C central station and Police Station Connected Burglar alarm installations require a 24 hour check in.
4. Grade A Local Burglar Alarm installation only refers to equipment of the protected premise. When remote alarm monitoring is required, the 7750 or 7750-F is suitable.
5. For Safe and Vault (S&V) installations, a rear pry-off tamper switch and a shock sensor, Listed for protection of sheet metal enclosures, is required on the subscriber unit, in addition to a cover tamper switch. (This also applies to any burglar alarm installation where the subscriber unit has to be mounted outside the protected area.)
6. UL Local Burglar- and Police Station Connected- burglar alarm installations are roughly the same as ULC's Local Burglar Alarm installation except there is no recognition for line security. Thus, Canada's Local Burglar Alarm installation would be Grade A with or without the connection of remote monitoring.
7. Grade A is a rough equivalent to Level I line security in Canada. Grade AA is roughly equivalent to Level II line security in Canada.

**For UL installations**, the wire linking alarm panel to 7750-F must use electrically supervised inputs (program the subscriber unit for Supervised or Fire Supervised accordingly). If inputs are not supervised, the 7750-F Subscriber Unit must be mounted a) no more than 3 feet away from the control panel, b) within the same room as the control panel with no intervening barriers between the two units and c) all interconnecting wiring from the control panel to the subscriber unit must be run in conduit or the equivalent. Supervision of the zone inputs must be in compliance with the requirements of NFPA 72 for the type of initiating device and initiating device circuit being monitored.

### Commercial Fire and Other Applications Requiring 60 Hour Backup Power

Use two (2) 12V / 7AH batteries. A second case is required, linked by conduit. Use a listed case, such as AES # 30-0022.

When required for UL Burglar alarm systems, use a UL Listed tamper switch on the cover of the battery enclosure.

\*If battery(s) are housed in separate enclosure, the enclosure must be connected by conduit to the subscriber unit. For burglar alarm installations in the U. S. the enclosure and the tamper switch for protection of the cover must be UL Listed. For Canadian burglar alarm installation the enclosure and cover tamper switch must be Listed for use in Canada.

Suggested accessory: AES box p/n 30-0022 (red box p/n 30-0022-RED).

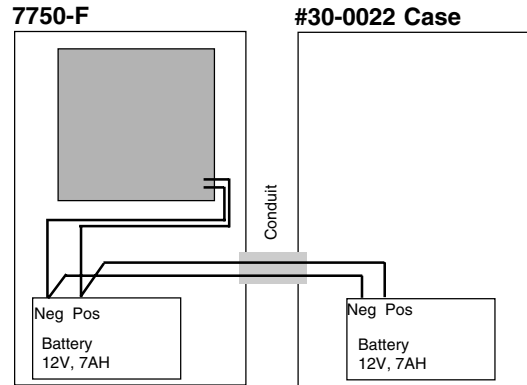

### Notes for Canadian Commercial Fire Alarm Installations

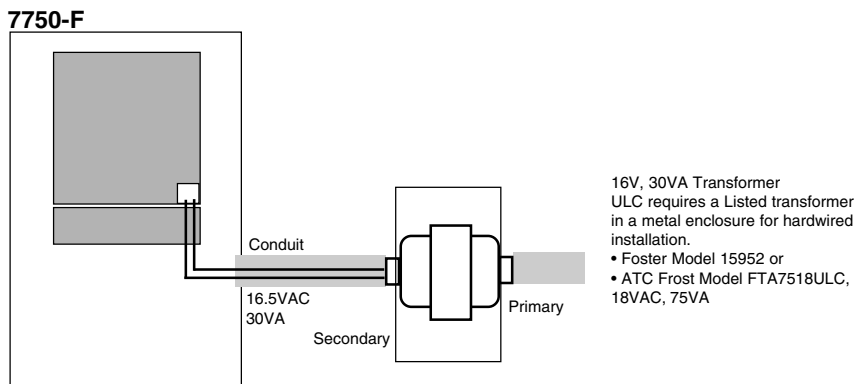

For cUL or ULC listed installations, the transformer must be permanently wired to its electrical outlet, or main power connection. It must be housed in a suitable metal enclosure, Listed for use in Canada, and that is provided with conduit connections. Suggested Transformers: Foster Transformer model 15952, or ATC Frost model FTA7518ULC. **The transformer may be mounted inside the case of the 7750-F, if space allows.**

**Signal Channel Security Levels:** The 7750-F is good for Level I and Level II Signal Channel Security.



## PHYSICAL INSTALLATION

### SUBSCRIBER UNIT

Choose a secure, dry location for the subscriber unit. The unit must be in a climate controlled area, avoiding extremes of heat or cold. Attach to a suitable, strong surface using proper fasteners. Pre-cut "knockout" holes are provided on the back and sides of the case for wiring access - After the subscriber unit is mounted, install the radio transceiver. For burglar applications, the unit should be located away from the alarm control panel - hidden if possible - and must be within the protected area. If an intruder attacks the control panel, the transceiver will still be able to send a signal.

### ANTENNA

The antenna should be mounted in a location near the transceiver to minimize signal loss due to cable length. Also, it should be located as high as possible, on or in the structure, with attics and rooftops locations preferred (Subscriber Unit must not be located in the attic as extremes of temperature can affect performance.) The antenna must be grounded properly to prevent lightning damage in accordance with building codes. To protect against attack for burglary applications, the antenna and cable must be within the secured area.

**Antenna Location is Important** - In many cases, the 2.5db case-mounted antenna (#7210-3-UR/C, below) is adequate. Otherwise, use a separate antenna positioned as high as possible and away from metal: some structures are insulated or sided with metal foil-backed materials, or may contain a lot of metal reinforcement inside the walls. This causes significant radio signal loss. In such cases, choose a location outdoors (inaccessible to intruders for burglary uses), in the attic (assuming that the roof has no foil) or near a window. Position the antenna away from metallic surfaces of any kind. Antenna must be mounted in a vertical position for best performance.

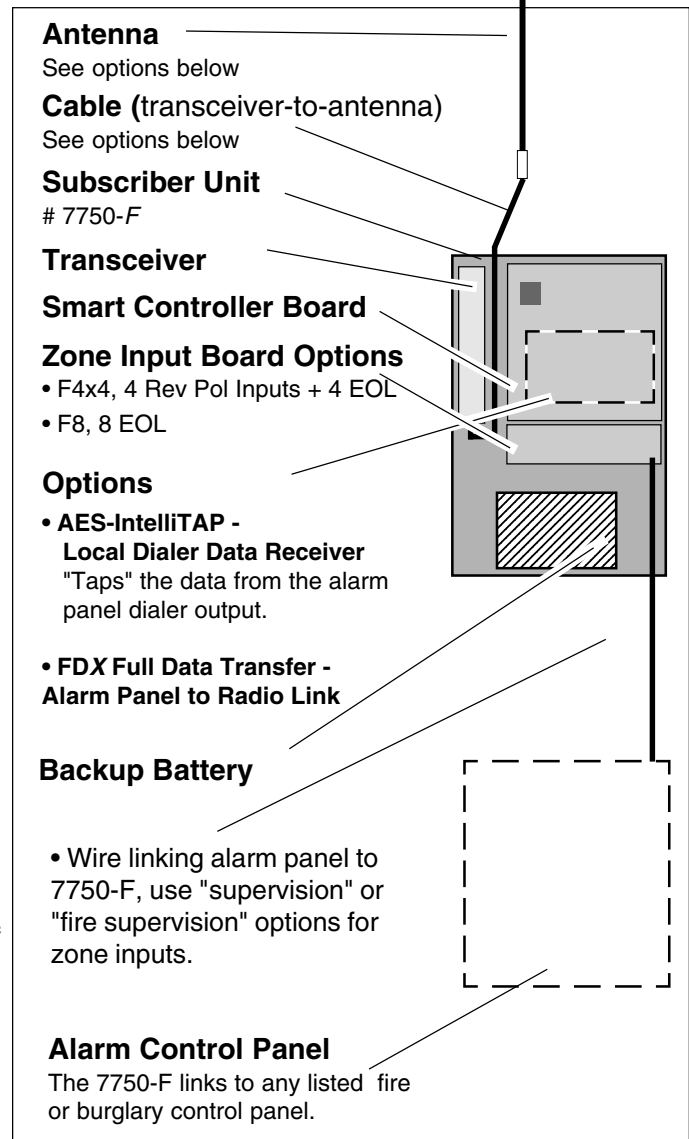

### ANTENNA OPTIONS (460-470 MHz)

- **2.5 db Antenna & Cable** - mounts on Subscriber Unit case, **order p/n 7210-3-UR/C**
- **3 db Stealth Antenna & Cable** - mounts in attics, vents, walls, behind drapes **order p/n 7211**
- **5 db Antenna\*** - steel mast, in/outdoor, with mount, 3 ft, **p/n 7210-5-UM**
- **6 db High Gain\*** - fiberglass mast, in/outdoor, with mount, 4.5 ft, **p/n 7210-6-UC**
- **7 db High Gain\*** - fiberglass mast, in/outdoor, with mount, 6 ft, **p/n 7210-7-US**

- **9 db High Gain\*** - fiberglass mast, in/outdoor, with mount, 8 ft, **p/n 7210-9-UC**

\*=requires cable, see below:

**CABLES, BNC/N, for all AES Subscriber Units,** hi performance, low loss for -UM, -UC and -US antennas. Cables and connectors are pre-assembled and tested.

- **10 Ft Cable, p/n 7220-10-N**
- **25 Ft Cable, p/n 7220-25-N**

## Power Up, Initial Programming

**NOTE:** When a subscriber unit is powered up, it immediately enrolls itself on the network, generating signals to the central station. Central station operators must be forewarned of activity on this account to avoid the chance of false alarm.

Connect handheld programmer to the controller board (see diagram, page 3). Note that all AES subscriber units use the same programmer, but there are two types of connector/cable assemblies. The 7750-F uses the type with the 6 pin modular telephone type plug at both ends (available from AES).

Connect power to the unit: 12V, 7AH (or larger) battery to battery terminals. Then, with the transformer NOT plugged in, connect the output of a 16-18VAC, 30-40 VA class II transformer to the power input terminals. Plug in power to the power input (see page 3). Be certain that the transformer is connected to an outlet that is NOT controlled by a switch. (See also UL and cUL Compliance notes on pages 4-8.)

After power is connected, **push Reset Button for a fresh reset.**

The controller runs a "self test". After a few seconds, a message will appear on the handheld programmer:

```
SELFTEST-PASS  
SUB [rev#] 7750F  
ID#: [4 digit ID number] (C)[YEAR] AES
```

If the message reads SELFTEST - PASS, you may proceed to the "Programming the Subscriber Unit" section. Note that the current ID# for this unit is displayed, as well as the software version and date.

If the messages reads SELFTEST - FAIL [Error Code], retry the procedure by pushing the controller RESET button (see diagram). Errors reported during the self test may be the result of transient conditions caused during a cold power up or by power interruptions during a programming procedure. Pushing the RESET button clears many of these problems.

If the Fail message persists, see the list of error messages on following page.

Repeat the procedure several times if necessary. If the unit consistently fails the self test, it must be serviced.

**SELF TEST ERROR MESSAGES:** An [Error Code] is listed when the unit fails the self test.

Some may be correctable on site. Check that all IC's are seated properly in their sockets - on rare occasions chips may come loose in shipment.

- Message: **01 Battery / power input is low.**  
 Procedure: Push RESET button, see if unit will pass self test; If the unit fails and reports the same message, replace battery and/or check main power voltage.
- Message: **02 Random Access Memory (RAM) Checksum failure;** may be caused by initial power up, or by power interruption during a programming procedure.  
 Procedure: Push RESET button, check if unit will pass self test; If unit passes, please note that it must now be reprogrammed (see next section). If unit fails, memory may be damaged and require service.
- Message: **03 Self test detects both problems 01 and 02 above.**  
 Procedure: Follow procedures described in 01 and 02 above.
- Message: **04 or 06, EEPROM Failure**  
 Procedure: Push RESET button. If the unit fails and reports the same message, EEPROM chip may be bad. Push RESET button: if unit passes, please note that it must now be reprogrammed (see next section). If unit fails, memory may be damaged and require service.
- Message: **08, Analog Digital Converter / ADC Failure**  
 Procedure: Same as 04 / 06 failure, see above
- Message: **80 Loopback Test Failure,** common on initial power up  
 Procedure: Push RESET button, unit will likely pass self test; If the unit fails repeatedly and consistently reports the same message, contact factory for service.
- Message: **100 AC Not Present**  
 Procedure: Check AC power input, transformer
- Other Messages: Unit requires AES authorized servicing. Report error code to AES service rep.

**IMPORTANT! STATUS INDICATORS - A Key Source of Information**

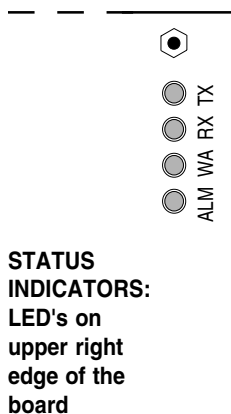

- TX** - indicates radio transmit
- RX** - indicates radio receive (includes any radio on activity on this frequency)
- WA** - Steady On = Waiting for acknowledgment of last transmission;
  - Steady Blinking = Not on Network;
  - Off = Normal
- AL** - Alert / troubleshooting indicator, "blink" codes as follows:
  - "." = short, "-" = long
  - . . . steady blink - system OK;
  - .. .. short-short blink - low battery;
  - .- .- .- short-long blink - an input zone is in alarm or trouble;
  - ..- ..- ..- short-short-long blink, low batt & zone in alarm/trouble;
  - . . . . short-pause-short-short, AC Fault
  - .. .. .. short-short-pause-short-short, AC fault & low batt
  - \_\_\_\_\_ steady / no blink - Selftest failure (excl low batt)

## PROGRAMMING THE SUBSCRIBER UNIT

Having passed the SELFTTEST procedure, you are now ready to program the subscriber unit. Previously programmed information is stored in nonvolatile memory, so the settings are not lost during a power down or failure condition.

### Overview of Programming Items:

- **THE ID NUMBER** selected for this subscriber unit must be unique, different from all other ID numbers in the system.
- **THE CIPHER** must be the same for all subscriber units and the central station on the network. The cipher serves as a password for units monitored by a specific central station. Thus if more than one AES-IntelliNet network is operating on the same radio frequency, the networks are kept separate by this code.
- **ENABLE REPEATING** function is used to enable or disable the subscriber units ability to relay messages. In general, enter Y/yes for all standard subscriber unit installations. However, mobile units must never use repeating - enter N/no for these applications.
- **CHECK-IN TIME\***: is the interval between supervisory signals to the central station. The allowable range is 1 minute to 24 hours. Use short check-in times **ONLY** for those installations that require it. Short check-in times create traffic that may slow the network speed.
- **THE REPORT DELAY\***: defines how often a unit can report an additional alarm. This allows the subscriber unit to accumulate multiple alarm events for each report, and assures the orderly flow of information through the network. The range is 0-330 seconds, the default is 10 seconds.
- **ZONE PROGRAMMING\***: The 7750F offers 2 zone input board options:
  - The "F-8", with 8 - EOL zone inputs,
  - The "F-4x4" with 4 - EOL inputs and 4 - reversing polarity inputs.Zones can be individually programmed. For the EOL inputs, choose from Supervised, Fire Supervised or Bypass. Other options include reporting of zone input Trouble\*\* and Restoral. Use Restorals **ONLY** for those installations that require it. Restorals create traffic that may slow the network speed.
- **ESCAPE/ ABORT FEATURE**: press the ESC escape key on the programmer to abort an operation at any time. NOTE: If you started to enter data and then press Escape, you may lose the data that was stored there. In this event, repeat the programming procedure.
- **TIMEOUT/SAFEGUARD FEATURE**: During programming, you have one minute to complete a function procedure. After one minute passes, the procedure is aborted. The message appears: TIMEOUT.

**\*NOTE:** Functions noted by a \* may be programmed using either the handheld programmer or the AES Net software supplied with the AES 7100/7700 Central Station Controller. It is much easier to use the Net software to program the subscriber units. **If the AES Net7K or Net77 software is used in the system, it is recommended that these functions be programmed using the Net software to enable it's powerful, centralized database capability.**

**\*\*NOTE:** Reporting of "Trouble" packets messages requires a version 1.70 or newer receiver. PRE-VERSION 1.70 RECEIVERS WILL NOT RECEIVE TROUBLE MESSAGES.

Check with the central station manager. If the receiver is pre-1.70, it should be upgraded to the current version. Contact AES Corporation or details.

**Procedure: SETUP UNIT - CTRL+F1**

The initial unit setup must be done with the handheld programmer.

NOTE: Entering new data with this function will overwrite (erase) any previously stored information on ID# and the Cipher Code. Pushing the ENTER key without entering new data saves the previously stored information. The programmer should be connected and the power should be on (as in self test).

To start, push Programmer keys (CTRL)+F1 (hold down the Control key and then the F1 key). The following message appears:

SETUP UNIT -OLD: NEW  
 ENTER ID#- 1234: \_\_\_\_\_

To keep previously stored ID#, simply push ENTER. To change the ID#, enter the 4 digit identification number for this unit using any of the 16 hex numerals, and then push ENTER. **The ID number must be unique, different from all other ID numbers in your system.**

After entering the ID number, the following message appears:

CPHR CODE - - XXXX: \_\_\_\_\_

Unit must be programmed with the cipher code chosen for your network. Enter the 4 digit dealer code as assigned by the system administrator, then push enter.

**NOTE:** The code must match that of the central station - If the wrong code is used, the unit cannot log on and will not work.

**NOTE:** DO NOT USE ZERO (0) AS A Cipher CODE. Zero is used at the factory for test and burn in purposes and should not be used in a live installation.

After entering the dealer code, the following message appears:

OK

**NOTE: The "SETUP UNIT" functions - Unit ID and Cipher - are the *only* functions that must be performed using the handheld programmer. You may complete the programming with the handheld programmer, but it is recommended that you program the remaining functions (timing, zone programming) using the AES Net software. Refer to the Net77/7K manual to complete the programming procedures.**

## Procedure: Set CHECK-IN TIME and REPORTING DELAY PERIOD - CTRL+F2

**The Check-In Time** is the interval at which the subscriber unit sends its “Check-in” messages to the central station. The range for this feature is 1 minute to 24 hours. For most applications, a check-in interval between 12 and 24 hours is used. More frequent check-ins are used for high security users. Note that shorter intervals create more network traffic.

- **Set Check in as required for UL Listed installations; set automation software accordingly.**
- See pages 4-8 for UL and Commercial Fire compliance notes.

**The Reporting Interval** is the time period after the initial alarm (which transmits instantly) and before the next transmission. The default value is 10 seconds, the range is 0 to 330 seconds. This function allows the unit accumulate alarm data between transmissions for optimum system performance.

- **For all Commercial Fire Alarm, UL Burglar Alarm, and Canadian Burglar Alarm installations, the Reporting Interval must not exceed 10 seconds.**

The programmer should be connected to J1 programmer port and the power should be on.

### To start, push Programmer keys (CTRL)+(F2)

Press programmer keys CTRL + F2 (hold down the Control and the F2 keys at the same time). The following message appears:

```
CHKIN TIME--OLD: NEW
ENTER HRS----HH:  __ [0-24] (HH = Previously programmed hours)
```

Enter a number between 0 and 24, and push ENTER.

Next, the minutes field appears

```
ENTER MINS---MM:  __ [1-59] (MM = Previously programmed hours)
```

Enter the number of minutes, a number between 0 and 59, and push ENTER.

```
NTR RPT DLY-NNN:  ___ [0-330] [seconds] (NNN= previously programmed delay)
```

Enter a number of seconds to allow between reporting of alarms; the range is 0 to 330; the default is 10 seconds.

If data has been entered correctly, the following message appears:

```
OK
```

### NOTES ON SELECTING A CHECK IN TIME:

- **Choose a check-in time in accordance with the security requirements of the installation**
- Except for high security applications, a check in time of 24 hours is typical.

The more frequent the check in times are set, the more traffic there is on the network.

Excessive traffic can cause delays in communications, and thus frequent check in times should be used only for highest security applications.

- Do not use a check in time of greater than 24 hours, 00 minutes.
- Also see UL and Fire Compliance section on pages 4-8.

## ZONE INPUT PROGRAMMING - OVERVIEW

The 7750-F zone inputs are connected to a special isolated circuit board. It is linked to the 7750-F processor board through optical couplers to keep unwanted energy from entering the main circuits.

The 7750F offers 2 zone input board options:

- The "F-8", with 8 - EOL zone inputs,
- The "F-4x4" with 4 - EOL inputs and 4 - reversing polarity inputs.

### 7750F-8

Zones 1-8 are E.O.L. input triggers which can be programmed for:

- E.O.L. / Supervised, using 3.01K end-of-line resistors , alarm on open or closed
- E.O.L. / Fire Supervised, reporting trouble for open circuits, alarm on closed
- Bypass, where the zone input is ignored.

### 7750F-4x4

Zones 1-4 are E.O.L. input triggers which can be programmed for:

- E.O.L. / Supervised, using 1K end-of-line resistors , alarm on open or closed
- E.O.L. / Fire Supervised, reporting trouble for open circuits, alarm on closed
- Bypass, where the zone input is ignored.

Zones 5-8 are reversing voltage inputs which are used to monitor reversing polarity output used on fire alarm and other equipment. , Zones 5-8 Programming Options:

- Supervised, reports alarm when input polarity reverses or if there is low or no voltage on the input
- Fire programming, Reports Alarms when input polarity reverses, and reports a Trouble if there is low or no voltage on the input.
- Bypass, where the zone input is ignored.

**For UL installations**, the wire linking alarm panel to 7750-F must use EOL / electrically supervised inputs (program the subscriber unit with "S" or "F"). If inputs are not supervised, the 7750-F Subscriber Unit must be mounted a) no more than 3 feet away from the control panel, b) within the same room as the control panel with no intervening barriers between the two units and c) all interconnecting wiring from the control panel to the subscriber unit must be run in conduit or the equivalent. Supervision of the zone inputs must be in compliance with the requirements of NFPA 72 for the type of initiating device and initiating device circuit being monitored.

The zone inputs can be programmed to match the output of the equipment being monitored by the 7750-F subscriber unit. The default setting is Supervised.

See diagrams in the next several pages for further details.

**ZONE RESTORALS:** Each zone can be programmed to report "restoral" to a normal status. Restoral reporting is usually reserved for higher security users, as it adds radio traffic to the system. Enable the zone restorals only when needed. The default setting is for "No" restorals.

**NOTE:** For systems using AES Net software in the central station, zone inputs can be programmed using that software. Zones can be set up using the handheld programmer, but it is easier to use the AES software for this task. Further, the subscriber data programmed using Net software is stored in the central station database.

## Zone Reporting Chart

| Zone Program:                   |                  | Bypass   | Supervised | Fire*    |
|---------------------------------|------------------|----------|------------|----------|
|                                 |                  | <b>B</b> | <b>S</b>   | <b>F</b> |
| <b>Zone Electrical State:</b>   |                  |          |            |          |
| <b>7750-F-8<br/>Zones 1-8</b>   | Open             | B        | A          | T*       |
|                                 | Resistor - 3.01K | B        | N          | N        |
|                                 | Closed/Short     | B        | A          | A        |
| <b>7750-F-4x4<br/>Zones 1-4</b> | Open             | B        | A          | T*       |
|                                 | Resistor - 1K    | B        | N          | N        |
|                                 | Closed/Short     | B        | A          | A        |
| <b>7750-F-4x4<br/>Zones 5-8</b> | Normal Polarity  | B        | N          | N        |
|                                 | Reverse Polarity | B        | A          | A        |
|                                 | Low/No Voltage   | B        | A          | T*       |

**Zone Report:**

**N**=Normal

**A**=Alarm

**T**=Trouble\*

**B**=Bypassed zone - no reports

**Programming for 7750F-8, Zones 1-8(E.O.L.):**

**S** = Supervised - 3.01K-EOL Resistor; 3.01K ohm = Normal / Open = Alarm / Short = Alarm

**F** = Fire - 3.01K-EOL Resistor; 3.01K ohm = Normal / Open = Trouble / Short = Alarm

**B** = Bypass - No Report

**Programming for 7750F-4x4, Zones 1-4 (E.O.L.):**

**S** = Supervised - 1K-EOL Resistor; 1K ohm = Normal / Open = Alarm / Short = Alarm

**F** = Fire - 1K-EOL Resistor; 1K ohm = Normal / Open = Trouble / Short = Alarm

**B** = Bypass - No Report

**Programming for 7750F-4x4, Zones 5-8 (Reversing Polarity):**

**S** = Supervised - Normal Polarity = Normal / Reverse Polarity = Alarm / Low-or-No Voltage = Alarm

**F** = Fire - Normal Polarity = Normal / Reverse Polarity = Alarm / Low-or-No Voltage = Trouble

**B** = Bypass - No Report

\*NOTE: Reporting of "Trouble" packets messages requires a version 1.70 or newer receiver.

PRE-VERSION 1.70 RECEIVERS WILL NOT RECEIVE TROUBLE MESSAGES.

Check with the central station manager. If the receiver is pre-1.70, it should be upgraded to the current version. Contact AES Corporation or details.



**Procedure: Zone Programming using the handheld programmer - CTRL+F3**

Press programmer keys CTRL + F3 (hold down the Control and the F3 keys at the same time). The following message appears:

```
FIRE/   - - - -OLD: NEW
TROUBLE PKT- Y:   .
```

The programming sequence first asks if any "Fire" inputs are to be used. Answer Y/yes if you wish to have the unit report "Trouble"\* conditions. Otherwise answer N/no (refer to chart on preceding page). The current programming is shown under the "OLD:" If you wish to change the setting, press Y or N, and push ENTER. To leave unchanged, simply push ENTER. Next appears:

```
ZONE BANK 0
SET ZONE (BSF) B0
OLD SSSSSSSS  LOW>HI
NEW .....
```

Individual zones can now be programmed. The valid programming options are shown in parentheses. The options that appear are determined by your input to the Fire/Trouble question above. The current programming is shown next to the word OLD, Zones 1-8 in order left to right. Your new entries will appear directly below, next to the word NEW. You must enter a valid letter for each of the 8 zones.

EOL Zone Inputs (Triggers) can be set for:

- B** - Bypass - No signals sent - all alarm, trouble conditions ignored;
- S** - Supervised/E.O.L. (alarm on open or short);
- F** - Fire Supervised E.O.L. (alarm on short; trouble\* on open)

Zones 5-8 Reversing Voltage (*7750-F-4x4 ONLY*) inputs can be set for:

- B** - Bypass - No signals sent - all alarm, trouble conditions ignored;
- S** - Supervised (alarm on reverse polarity of input; alarm on loss of voltage);
- F** - Fire (alarm on reverse polarity; trouble\* on loss of voltage)

Press ENTER after entering selections. Next appears:

```
SET RESTORAL (XR) B0
OLD XXXXXXXX  LOW>HI
NEW .....
```

You can program individual zones to report restorals - ie return to normal status. X= Restorals Not Reported; R=Restorals Reported. The existing or OLD programming is shown for each zone. Your new entries will appear directly below, next to the word NEW. You must enter a valid letter X or R for each zone. Press ENTER after entering selections. When all is complete, the OK message appears.

OK

**\*Important Note:** Reporting of "Trouble" packets messages requires a version 1.70 or newer receiver. PRE-VERSION 1.70 RECEIVERS WILL NOT RECEIVE TROUBLE MESSAGES.

Check with the central station manager. If the receiver is pre-1.70, it should be upgraded to the current version. Contact AES Corporation or details.

## Wiring EOL Zone Input Triggers for Subscriber Unit

Each zone trigger in the 7750-*F* area used with an E.O.L. resistive loop, using an end-of-line resistor. See preceding pages for zone programming.

Unused zones may be bypassed.

**IMPORTANT NOTE:** Isolated input board requires power, 8-28VDC. Refer to section below.

### E.O.L. INPUT TYPE: SUPERVISED or FIRE (also, see chart on page 16)

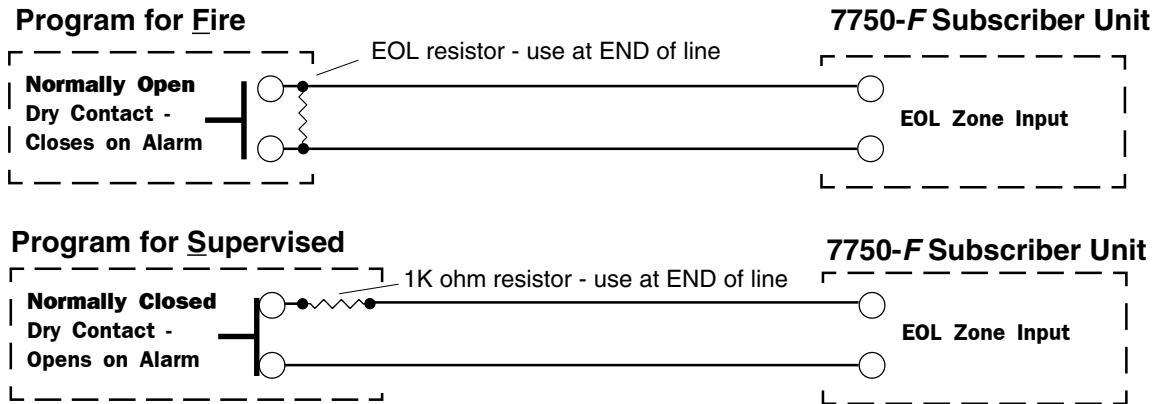

**7750-F-4x4 NOTE:** Maximum resistance of E.O.L. input, including wire and EOL resistor, is 1100 ohms. Thus, when using the 1K ohm resistor supplied, wire resistance must not exceed 100 ohms.

**7750-F-8 NOTE:** Maximum resistance of E.O.L. input, including wire and EOL resistor, is 3301 ohms. Thus, when using the 3.01K ohm resistor supplied, wire resistance must not exceed 300 ohms.

### 7750-F-4x4 *only*: Wiring Reversing Polarity Inputs, Zones 5-8

**INPUT TYPE: REVERSING POLARITY** - Alarm occurs input voltage when polarity is reversed.

- Input Voltage range is 10-30V
- These inputs are self powered
- Program 7750-*F* zone for Fire (see section on Zone Programming)

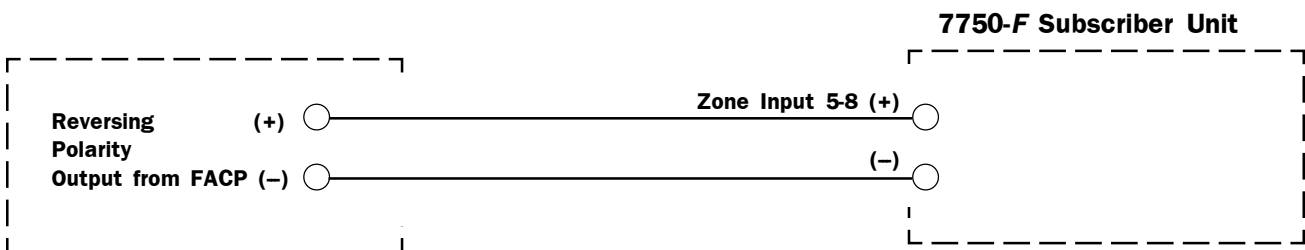

## Providing Power for Input Board Model 7750-F-4x4 (Zones 1-4 only)

**IMPORTANT NOTE:** Zone 1-4 of the isolated input board requires power, 8-28VDC (see page 3).

To power this input board, choose one of the following:

**A:** Use the battery of the Subscriber unit. NOTE: this introduces earth ground to the inputs, which may cause a trouble condition on the inputting device.

**or, B:** Use the power from the alarm panel (thus avoiding the earth ground).

**To monitor power on the input board,** connect the power to one of zones 5 - 8, and program that zone for "Fire" (see zone programming). If power is lost, this zone will report a "trouble" condition, indicating a power loss at the input board. (This is not necessary if the input board is powered by the subscriber unit battery.)

**Zones 1 - 4, Input Triggers**  
Typical Input: Dry Contact  
Programmable Options:  
Supervised EOL; Fire EOL;  
Restorals; Trouble; Bypass  
Shown: Wired for Fire/EOL:  
1K resistor = Normal  
Close = Alarm  
Open = Trouble

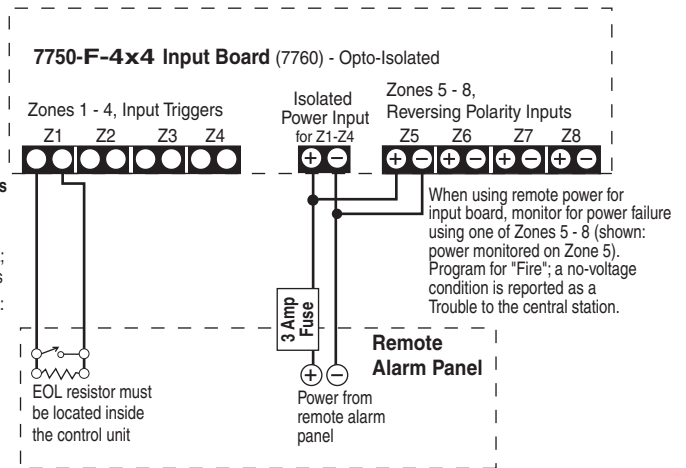

## Providing Power for Input Board Model 7750-F-8

**Power must be provided to 7761 "F-8" input board.** Requires 8-28VDC to terminals (J3) at lower left of input board. Internal battery may be used, but earth ground will be tied to common terminals. This may affect connection to other panels. If earth ground cannot be used, supply the input board with power from the alarm panel.

**To monitor power on Input Board when powered by an alarm panel:** For all Commercial Fire, UL burglar and Canadian UL burglar alarm installations, use one of the zones as a power fail report. Install a 3.01K resistor on the designated zone terminals. Program the zone for F / Fire. When power to the input board is lost, zone will report a "Trouble". Flag this as a power failure at the central station / automation software.

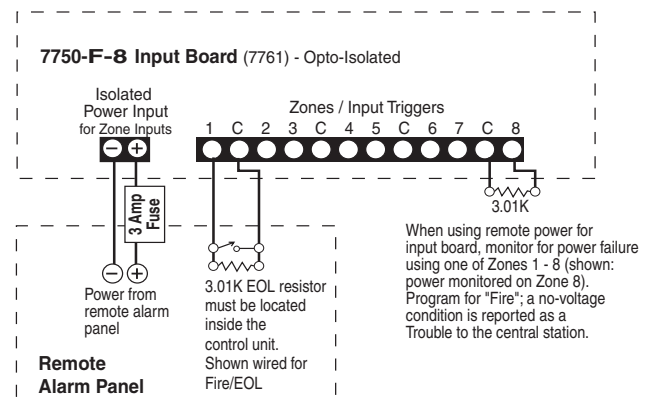

## CONFIRM PROGRAMMING - RESET

To confirm this procedure, press the RESET button on the controller to check the program. The reset function runs the Selftest, which prints out the ID number:

```
SELFTEST - PASS
SUB [rev#] 7750F
ID#:NNNN (C)[date] AES
```

(If "FAIL" messages appears, push RESET again; If Fail persists, go to page 11 to troubleshoot.)

**Proceed to "Initializing the Subscriber Unit", next page.**

## INITIALIZING THE SUBSCRIBER UNIT

Having passed the self test and programmed the unit, you are now ready to introduce it to the radio network. It is assumed that an AES•*IntelliNet* central station is actively monitoring the network and can respond to the new subscriber unit as it comes on line.

Power down the subscriber unit by disconnecting both the battery and power input. Connect programmer to subscriber unit (if you have not already done so).

Connect the antenna to the transceiver (if you have not already done so). Do not operate transceiver without the antenna connected!

Connect the controller-to-transceiver cable with 9 pin connector to the radio transceiver.

Connect the battery first, and then the AC primary power. The controller power indicator should be on. The Programmer should be connected as described earlier.

Push the Reset button on the controller board (see diagram page 3).

At this point, the message on the programmer should read:

```
SELFTEST - PASS
SUB [rev#]    7750F
ID#:NNNN (C)[date] AES
```

(If an "Fail" error message is displayed, push the reset button. If an error message continues to appear, see page 11 for possible solutions.)

When the reset button is pushed, the subscriber unit goes on the air to query the other subscriber units to set up the best route(s) to link with the central station. The status lights indicate the process:

- RX, TX and WA lights will all come on briefly, testing the LED's.
- RX comes on during loop back test (a self test);
- TX comes on sending a "Receiver Not in Service" message - a standard power up event;
- AL + WA will blink at different but steady rates
- TX comes on again as unit transmits a "Request for Reply" from other subscriber units
- WA stops flashing after about 30 seconds **IF** one or more other subscriber units reply to the "Request", (otherwise the WA continues to flash, indicating the unit is not on the network);
- TX comes on again (if WA stops flashing) to send first "Check-In";
- AL blinks at a steady rate, indicating a normal condition.

When the unit receives a valid acknowledgment, the WA light will turn off. This indicates that the subscriber unit is now connected to the network.

**IMPORTANT NOTE:** A flashing WA light (blinking at a steady rate) indicates that the subscriber has NOT linked itself into the network. Check antenna and all cables; be sure that correct system cipher has been programmed in to the unit.

The next step is to perform a status check.

**Procedure: STATUS CHECK - SHIFT +F4**

Performs a quick diagnostic check at any time.

Connect the programmer to J1 programmer port. Be sure that radio and antenna are connected, and power is on.

Press programmer keys SHIFT+F4 (hold down the Shift key and then press the F4 key). The following message appears:

```
SUB [rev#]      7750F
ID#[NNNN] (C)YYYY AES
RT1:NNNN LEVEL: NNN
STAT:NNN NETCON: N
```

**EXPLANATION OF STATUS CHECK TERMS**

**ID#:** 4 digit ID number programmed into this unit.

**LEVEL:** refers to the subscriber unit "level" or "link layer", which tells you how many "hops" the message packet must make to get to the central station. In general, if the number is 1, then this unit is communicating directly with the central station. If the number is 2, the unit relays its message through one other subscriber unit to reach the central station. If the number is 3, the message goes through 2 other subscribers ... and so on. Also, the level number of subscriber with a weak signal to the unit on the top of its routing list will be incremented. by 1. A unit level = 255 indicates that unit is not on network.

**RT1:** refers to the "first route" or primary route in the routing table. The 4 digit number is the subscriber unit ID of the next hop to the central station. If the unit is communicating directly with the central station, the 1ST RT is 0000 - the central station ID number. If the subscriber is using intermediate units to communicate, the RT1 number is the ID number of first subscriber on the message route. If XXXX appears, the unit is not on the network.

**Dynamic Routing Table:** Each subscriber unit maintains a list of up to 7 alternate routes. Routes are prioritized according to signal strength and NETCON ratings. This function is dynamic, and is updated constantly.

**STAT:** Status - shows self-test results (see page 11 for codes).

**NETCON:** "NETwork CONnectivity". This is an internal rating function used by the subscriber units to align themselves in the network. The scale is 0 to 7, 0 being best. Readings of 5 or 6 are common. Units at the end of the path may show a 7.

Minimum criteria for a "good" repeater are as follows:

1. RF signal exceeds marginal threshold
2. No faults indicated in status (such as low battery)
3. Level/Link Layer of repeater is less than or equal to this unit's
4. Signal received from unit a least once every 6 hours
5. NETCON of repeater is less than 7

continued...

## OTHER PROGRAMMING FUNCTIONS

### DEFAULT RESET CTRL+F5

The Default (Master) Reset function can be used to reset programmed values to their default settings. **The ID# and Cipher are not changed. Use this function only if you wish to reset all parameters.** Power must be on. Connect the programmer to J1 / programmer port.

Press programmer keys CTRL+F5 (hold down the Control key and then press F5 key).  
The following message appears:

```
RESET RAM? <Your Response:>
           (Y) (Enter) for YES, or
           (N) (Enter) for NO
```

If you answer (Y) Yes, all program parameters will be restored to their default values. The subscriber then goes through its normal "reset" routine. The following message appears:

```
SELFTEST - PASS
SUB [rev#] 7750F
ID# : [4 digit ID number] (C)[date] AES
```

The default reset restores program parameters to their default values:

|                          |  |
|--------------------------|--|
| CHECK IN TIME:           | 24 Hours 00 Minutes  |
| ZONE INPUT PROGRAMMING:  | Supervised, All Zones;<br>NO Restorals Reported, All Zones;                  |
| REPORT INTERVAL (DELAY): | 10 Seconds   |
| UNIT ID #:               | NOT Changed by Default Reset   |
| CIPHER                   | NOT Changed by Default Reset   |
| REPEATING                | Enabled  |
| TIME TO LIVE (TTL)       | Enabled for Check-Ins only, 30 minutes<br>(All other packets - TTL disabled) |

## OTHER FUNCTIONS, continued

### MONITORING Using the Handheld Programmer

Installers can view network data “traffic” on the handheld programmer at a remote site. It is not a practical way to “read” data (it scrolls off the screen quickly), but it can be useful to see that data is being sent or received. Three monitor functions can be enabled:

#### RECEIVE MONITOR ON/OFF

PROCEDURE: Push programmer keys **(SHFT)+(F1)**

MESSAGE: RX MONITOR ON (OFF)

Hold down the Shift key and then press the F1 key to enable or disable (toggle) the display of data addressed to this unit.

#### TRANSMIT MONITOR ON/OFF

PROCEDURE: Push programmer keys **(SHFT)+(F2)**

MESSAGE: TX MONITOR ON (OFF)

Hold down the Shift key and then press the F2 key to enable or disable (toggle) the display of messages transmitted by this unit.

#### MONITOR ALL ON/OFF

**NOTE:** Requires that Receive Monitor must be on - Enter (SHFT)+(F1)

PROCEDURE: Push programmer keys **(SHFT)+(F3)**

MESSAGE: MONITOR ALL ON (OFF)

Hold down the Shift key and then press the F3 key to enable or disable (toggle) the display of all network messages within range of this unit.

The monitor functions should be disabled when installation and testing is complete.

**NOTE:** Text messages cannot be received when any of the monitoring functions are in use. Use these functions only for test purposes. Toggle the functions OFF when testing is complete, or press Reset Switch (see page 3).

## KEY TRANSMITTER - SHFT+F5

This function activates the transmitter for 6 seconds. This allows the installer to use external test equipment (SWR, power meter, etc.) to test the radio power, cables connections, antenna tuning and other radio parameters. It is assumed that the programmer is connected to the subscriber, the transceiver is connected to the subscriber circuit board, power is on and the antenna is connected.

PROCEDURE: Push programmer keys (SHFT)+(F5)

MESSAGE: KEYING TX..

Activating this function causes the transmitter to go on the air for 6 seconds, and then shut off automatically. Press the ENTER key to cancel the transmit test.

## SENDING ASCII TEXT MESSAGE (F5)

Text messages can be sent from the subscriber unit to the central station.

PROCEDURE: Push programmer key (F5)

MESSAGE: ENTER MSG:  
\_ [Enter your text message, up to 200 characters. Push ENTER to send.]

If not data is entered within approximately 60 seconds, the unit will exit the text message mode. Note that the unit is unable to transmit or receive while in this mode

## RECEIVING ASCII TEXT MESSAGES

Messages can be sent from the central station to any subscriber unit. If the handheld programmer is connected to the unit, the message will be displayed on the screen and a beep will sound. This is a handy feature for communications between installers and central stations.

**NOTE:** Text messages cannot be received when a monitor function is in use.

## ENABLE REPEATING - CTRL+F4

To start, push Programmer keys (CTRL)+F4 (hold down the Control key and then the F4 key. The following message appears:

ENABLE RPTNG (Y): \_ ← previously stored data  
enter new data (Y/N) here

For most installations, enter a “Y” for YES, and then push ENTER.

**NOTE:** This enables the repeating function which is critical to the proper operation of the AES network. In general, repeating is disabled *only* for mobile units.

To disable this unit from forwarding messages, enter “N” for NO, and then push ENTER. Mobile units such as the 7050MMP or the 7550VLS must not be used for repeater functions.

OK



## PACKET TIME-TO-LIVE PROGRAMMING - F2

7750-F Ver 2 subscribers include the new "Time-To-Live" or "TTL" function. The TTL function ensures a smooth, continuous flow of data through the AES-IntelliNet system.

Like the Internet, AES-Intellinet is a packet-based technology. The Time-to-Live concept in the Internet is based on the fact that all data has a useful life. This is also true in the security industry. Statistics show that 95+% of all data sent through the AES-Intellinet system are check-in/test timer packets. These messages can be burdensome to both the network and the alarm automation software attached.

The benefits of TTL are best exhibited when the central station goes off line due to a lightning hit or some other unlikely, catastrophic event. While the receiver is off line, messages traveling through the system are stored in the individual subscriber units for later delivery. Under the default TTL settings, unimportant test timer messages are deleted from the subscriber unit memory after 30 minutes of being delayed in the network. Thus, the system will not have to handle the message when the central receiver comes back on line. All other messages, such as alarms, etc. speed there way to the central station as they normally do.

### NOTES:

- Even when a check-in packet is deleted due to a delay, the objective of that message has already served: the late or missing signal has been flagged at the central station.
- Under the default (factory) settings, only test timer messages are subject to the TTL function. If you want TTL for other message types, YOU must activate it when you program the subscriber unit (F4 on the handheld programmer).
- The TTL feature works best when the majority of subscribers, or the subscribers that are most heavily used, have the feature in the firmware. Call your AES representative for upgrade information.

To start, push Programmer key **F2**. The following message appears:

```

PACKET TIME TO LIVE
CHECK IN --- OLD:NEW
ENTER HRS --- 00:..

```

*Previously stored data*

*Enter new data here*

Enter new data Hours 0-24, or push ENTER to accept old data. Next appears:

```

ENTER MINS --- 30:..

```

Enter new data Minutes 0-59, or push ENTER to accept old data.

Default time for Check-In Packets is 00 hours, 30 minutes. DO NOT enter a greater than 24 hrs 00 mins. Entering a time of 00 hours and 00 minutes deactivates the time-to-live function for that packet type. The shortest allowed TTL time is 00 hours, 10 minutes.

Next appears

```

STATUS - - - - - OLD:NEW
ENTER HRS - - - - 00:..

```

*The sequence repeats for other packet types*

The sequence now repeats for:

- Status Packets
- Alarm Packets
- Trouble / Trouble-Restoral Packets
- Zone Restoral Packets
- AES-IntelliTAP Packets
- Special Packets (Vending, etc.)

The default time for the 6 packet types above is 00, i.e. the time-to-live function is deactivated for these packets. Entering anything greater than 00 HRS and 10 MINS will enable the Time-to-Live function.

Press ENTER to accept existing "old" data.

## PROGRAMMING THE SUBSCRIBER UNIT FROM A PC

*In place of a handheld terminal*

An cable adapter kit #7043 may be ordered from AES to link the 7750-*F* to your computer serial port.

Communications Parameters: 4800 baud, NO parity, 8 data bits, 1 stop bit,  
RTS/CTS Flow control OFF

Handheld (HH) Programmer Key equivalents to PC Keyboard:

| <u>HH</u>   | <u>PC</u> | <u>HH</u>    | <u>PC</u> | <u>HH</u>   | <u>PC</u> |
|-------------|-----------|--------------|-----------|-------------|-----------|
| F1 = CTRL-Q |           | SHIFT F1 = a |           | CTRL-F1 = f |           |
| F2 = CTRL-R |           | SHIFT F2 = b |           | CTRL-F2 = g |           |
| F3 = CTRL-S |           | SHIFT F3 = c |           | CTRL-F3 = h |           |
| F4 = CTRL-T |           | SHIFT F4 = d |           | CTRL-F4 = i |           |
| F5 = CTRL-U |           | SHIFT F5 = e |           | CTRL-F5 = j |           |

### REMARKS:

- When entering Hex numbers, use uppercase, i.e.. "9A" not "9a"
- If possible, set terminal program for "destructive backspace" so that backspace will erase the deleted character from the screen.
- If nothing is sent or received by the 7750-*F*, make sure the program is set to the correct COM port.
- If characters are received by the 7750-*F*, but nothing can be sent, make sure the CTS/RTS flow control is OFF, and that the cable is OK.

### Antenna Disconnect / Acknowledgment Delay Output (Terminal J4)

The 7750-*F* monitors radio traffic on its frequency. If the channel is "quiet" for more than 4 minutes (as would be the case if the antenna was disconnected) the 7750-*F* subscriber tests the channel by sending a test message to a unit within its routing table. If that message is not acknowledged within the programmed acknowledgment delay period (default is 2 minutes\*), a fault condition exists. This fault is annunciated by a voltage (12V) at the pins on J4 (see diagram, page 3). The voltage can be used to drive a relay, sounder or other device to notify someone of the condition. Maximum load is 200 ma.

**Mating Output Connectors:** Order part number 12-0388-J4 for a package of 10 mating connectors for the J4 output pins.

\*programmed through Net7K or Net77 Central Station Controller Software

## 7750-*F*-Series SUBSCRIBER UNIT SPECIFICATIONS

**SIZE:** 13.25"h x 8.5"w x 4.3"d  
34 cm x 21.5 cm x 11 cm

**WEIGHT:** 6.4 pounds (2.9 kilograms) (exc battery)

**RADIO:** Standard Frequency Ranges (others available) 450-470 MHz.  
Standard Radio Output Power: 2 Watts (others available) *All radio systems require FCC licensing;*

**POWER INPUT:** 16VAC, 30VA

**ZONE BOARD POWER INPUT:** 8-28VDC (not required for Reverse Polarity inputs)

**VOLTAGE:** 12VDC nominal

**CURRENT:**

|                             | <u>7750-F-4X4</u> |                 | <u>7750-F-8</u> |                 |
|-----------------------------|-------------------|-----------------|-----------------|-----------------|
|                             | <u>Standby</u>    | <u>Transmit</u> | <u>Standby</u>  | <u>Transmit</u> |
| Subscriber Unit Only        | 230ma             | 1.2A            | 584ma           | 1.55A           |
| Subscriber Unit & 7068 'Tap | 295ma             | 1.3A            | 660ma           | 2.00A           |

### INPUTS:

**7750-F-4x4** 8 zones: 4 zone triggers - EOL (1K); 4 Reversing Polarity inputs

**7750-F-8** 8 zones, zone triggers, EOL (3.01K)

Input Option: AES 7068 IntelliTap Dialer Output / Radio Interface

**OPERATING TEMPERATURE RANGE:** 0° to 50° C (32° to 122°F)

**STORAGE TEMPERATURE RANGE:** -10° to 60° C (14° to 140°F)

**RELATIVE HUMIDITY RANGE:** 0 to 85% RHC, Non Condensing

**BACK-UP BATTERY:** 12V, 7 AH (min), lead acid gel type; required for all installations

**LOW BATTERY REPORTING:** 22.5 Minute Test Cycle (approx)

**AC FAILURE REPORTING:** Reports to central station after approximately 4 minutes without AC power; reports AC power restoral after approximately 4 minutes of restored power.

**ANTENNA DISCONNECT/ LOCAL REPORTING:** Fault is annunciated by a ground (+12V open collector) at pins on J4 on the main circuit board; 200ma max load.

### • FCC COMPLIANCE

NOTE: This equipment has been tested and found to comply with the limits for a Class B digital device, pursuant to Part 15 of the FCC Rules. These limits are designed to provide reasonable protection against harmful interference in a residential installation. This equipment generates, uses and can radiate radio frequency energy and, if not installed and used in accordance with the instructions, may cause harmful interference to radio communications. However, there is no guarantee that interference will not occur in a particular installation. If this equipment does cause harmful interference to radio or television reception, which can be determined by turning the equipment off and on, the user is encouraged to try to correct the interference by one or more of the following measures:

Reorient or relocate the receiving antenna;

Increase the separation between the equipment and the receiver;

Connect the equipment into an outlet on a circuit different from that to which the receiver is connected;

Consult the dealer or an experienced radio/TV technician for help.

CAUTION: Changes or modifications to this equipment not expressly approved by the party responsible for compliance could void the user's authority to operate the equipment.

### • CANADIAN COMPLIANCE

This digital apparatus does not exceed the Class B limits for radio noise emissions from digital apparatus as set out in the interference-causing equipment standard entitled "Digital Apparatus", ICES-003 of Industry Canada.

Cet appareil numérique respecte les limites de bruits radio électriques applicables aux appareils numériques de Classe B prescrites dans la norme sur le matériel brouilleur: "Appareils Numeriques", NMB-003 édictés par l'Industrie Canada.

### WARNING:

- It is unlawful to operate this equipment without a valid FCC radio station license.
- If the antenna or cables connected to this equipment come in contact with electrical power lines, DEATH or SERIOUS INJURY may result.
- Never install the antenna where people may come in contact with it as SERIOUS INJURY may result.
- Test this system periodically for proper operation. AES assumes no responsibility for this equipment's failure to operate. AES's sole responsibility is to repair or replace any AES device found to be defective during the warranty period.

## AES THREE YEAR OWNER WARRANTY

We warrant AES products to be free from defects in material and workmanship for three (3) full years from date of purchase.

At no cost to the original purchaser for parts or labor, AES will repair or replace any part or parts which are judged defective under the terms of this Warranty.

Defective products must be returned to AES directly, provided they are properly packed, postage prepaid. Or exchange may be made through any authorized direct factory representative for any products which are judged defective under the terms of this Warranty.

This Warranty is in lieu of all other Warranties expressed or implied and of all other obligations or liabilities on the part of AES. This Warranty does not apply to any product or any part thereof which has been repaired or altered outside our factory in any way to affect its stability or reliability, or which has been subjected to misuse, negligence or accident, or which has had the serial number effaced or removed. Neither shall this Warranty apply to any product which has not been installed, applied or used in strict accordance with our instructions.

AES Corporation cannot be aware of, or responsible, for the differing values of property to be protected by its alarm reporting systems. The above Warranty is given in lieu of all other Warranties, either expressed or implied, including a Warranty of fitness for a particular purpose, and manufacturer shall not be liable for any defect, incidental or consequential, loss or damage arising out of the failure of the product to operate.

Some states do not allow the exclusion or limitation of incidental or consequential damages, so the above limitation or exclusion may not apply to you.

This warranty gives you specific legal rights and you may also have other rights which vary from state to state.

**AES IntelliNet**

**SERVICE PROCEDURE:** Authorized repair service is furnished only by AES Corporation.

Contact AES Corporation at 978-535-7310 (fax 978-535-7313) to receive a Return Authorization Number. Have the AES part number and serial number ready. Repack equipment in original or equivalent packaging. Inside the box, please include a contact name, telephone number, address and a brief description of the reason for return.

Ship items freight-prepaid to:

Repair Services, RA# \_\_\_\_\_ (call for Return Authorization number)  
AES Corporation  
285 Newbury St  
Peabody, MA 01960 USA

# Quick Programming Guide for 7750-F Ver. 2 Subscriber

Complete details of these procedures are provided in the manual. This page provides a handy reference sheet for technicians familiar with the AES•IntelliNet system who are using a handheld programmer to install or update the parameters of a subscriber unit.

**NOTE:** With the exception of the initial "Setup Unit" section, programming can be done from the AES Net central station software.

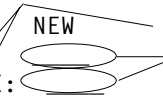
| FUNCTION                            | PROGRAMMER SCREEN   | NOTES  |
|-------------------------------------|---|--|
| <b>SETUP UNIT</b><br>(CTRL)+(F1)    | <pre> SETUP UNIT -OLD: NEW ENTER ID#- 1234: CIPHER CODE XXXX:                     </pre>                           | <p>Shows existing "old" ID#, but hides Cipher (Dealer) Code</p> <p>Enter new data, or push enter to keep old data;</p> <p>Caution: Cipher must match for all subscribers and central receiver (Legal characters are hex numerals 0123456789ABCDEF)</p>   |
| <b>CHECK IN TIME</b><br>(CTRL)+(F2) | <pre> CHKIN TIME--OLD: NEW ENTER HRS----HH:  _ [0-24] ENTER MINS---MM:  _ [1-59]                     </pre>   | <p>Range = 00 Hrs, 01 Min to 24 Hrs, 00Mins</p> <p>(minutes field appears if digits are entered in hours field)</p>  |
| <b>REPORT DELAY</b>                 | <pre> NTR RPT DLY-NNN:  _ [0-330]                     </pre>  | <p>[seconds, default is 10]</p>  |
| <b>ZONE SETUP</b><br>(CTRL)+(F3)    | <pre> FIRE/ ----OLD: NEW TROUBLE PKT Y:  . [Y/N]  ZONE BANK 0 SET ZONE (BSF) B0 OLD SSSSSSSS LOW&gt;HI NEW _____  SET RESTORALS (XR) B0 OLD XXXXXXXX LOW&gt;HI NEW _____                     </pre> | <p><b>Programming Zones:</b></p> <ol style="list-style-type: none"> <li>1. Answer Y/yes if you are using Fire inputs. This enables the unit to generate "Trouble" packets* (messages) for Fire type inputs. Otherwise, answer N/no. See definition below.</li> <li>2. "Set Zone" sets individual zone programming. The options [BSF] or [BS] are displayed in brackets; these vary according to your answers Y/N to zones part 1. above. <p>There are 8 spaces, each representing one of the 8 zones, numbered Low&gt;Hi, or 1 to 8, left to right.</p> <p><u>B</u>=Bypass</p> <p><u>S</u>=Supervised EOL, 2 Level Supervision</p> <p><i>No trouble signals are sent</i></p> <p>Zones 1-4, Supervised means: Alarm=Short, Normal=1K resistor, Alarm=Open</p> <p>Zones 5-8, Fire means: Alarm=Reverse Polarity, Normal=Normal Polarity, Alarm=No/Low Voltage</p> <p><u>F</u>=Fire Supervised EOL, 3 Level Supervision, see above</p> <p>Zones 1-4, Fire means: Alarm=Short, Normal=1K resistor, Trouble=Open</p> <p>Zones 5-8, Fire means: Alarm=Reverse Polarity, Normal=Normal Polarity, Trouble=No/Low Voltage</p> </li> <li>3. <b>Restorals</b> - All zones can be programmed to report restorals, i.e. when the zone returns to its normal state after an alarm condition</li> </ol> <p>There are 8 spaces, each representing one of the 8 zones, numbered Low&gt;Hi, or 1 to 8, left to right.</p> <p>Enter "R" for Restoral, Enter "X" for no restoral</p> |

**\*Important Note:** Reporting of "Trouble" packets messages requires a version 1.70 or newer receiver. PRE-VERSION 1.70 RECEIVERS WILL NOT RECEIVE TROUBLE MESSAGES.

Check with the central station manager. If the receiver is pre-1.70, it should be upgraded to the current version. Contact AES Corporation or details

## Programming Codes - Quick Reference, continued

|  |   |  |
|--|---|--|
| <b>ENABLE REPEATING</b><br>(CTRL)+(F4) | ENABLE RPTNG-Y: _   | Enter Y to enable repeating capability (page 26)   |
| <b>MASTER RESET</b><br>(CTRL)+(F5)     | RESET RAM? [Y/N]  |  |
| <b>DISPLAY STATUS</b><br>(SHIFT)+(F4)  | SUB N.NN 7750F<br>ID#:NNNN (C)YYYY AES<br>RT1:NNNN LEVEL: NNN<br>STAT:NNN NETCON: N                   | Version Number and Subscriber Type<br>ID # and Copyright<br>ID of #1 in 1st Route; Link Layer Number<br>Status/Error Message (if any); Netcon Rating |
| <b>KEY TRANSMITTER</b><br>(SHIFT)+(F5) | KEYING TX..   | (6 second test)  |
| <b>SEND TEXT MESSAGE</b><br>(F5)       | ENTER MSG:  | Sends text message to central receiver   |
| (SHIFT)+(F1)                           | RECEIVE MONITOR ON/OFF  | (toggle)   |
| (SHIFT)+(F2)                           | TRANSMIT MONITOR ON/OFF   | (toggle)   |
| (SHIFT)+(F3)                           | MONITOR ALL ON/OFF  | (toggle)   |
| <b>F2</b>                              | PACKET TIME TO LIVE<br>CHECKIN-----OLD:NEW<br>ENTER HRS----00:..<br>ENTER MINS---30:..<br>[continues] | See page 25  |