

040 HD

INSTRUCTION MANUAL

IMPORTANT! Read these instructions before you use your new 040 HD Key Machine.
Ensure that all safety recommendations are followed!
See page 3 for instructions.



PERFORMANCE
Series

This manual applies specifically to the 040 HD Performance Series key machine. It properly identifies your model and assures you will receive correct parts, if and when you require replacement parts. Retain this manual in a safe place. If ownership of this machine is transferred, this service manual should accompany the machine.

When seeking service information about this machine, refer to Model No. 040 HD and the part number desired (see pages 6 to 8). Note that many parts are not interchangeable with other KABA ILCO machines.

CONTENTS

Warranty	2
Safety Information	3
Introduction to the 040	4
Operating Parts (illustrated)	5
Exploded View	6-7
Exploded View Parts List	8
How to Duplicate Keys.....	9-10
The Cutting Operation	11-12
Replacements and Adjustments	13 -14

ONE YEAR LIMITED WARRANTY

KABA ILCO warrants to the original buyer of any new model 040 HD machine that it will repair or replace, at its option, any part of any machine which proves, to the reasonable satisfaction of KABA ILCO, to have defects arising from the faulty manufacture of the machine or from defective material or components, during a period of one (1) year from the date of shipment of the machine by KABA ILCO, provided that the machine is returned by prepaid transport to KABA ILCO or to its authorized representative before the expiry of the warranty period together with a detailed description of the alleged defect(s). KABA ILCO may, at its discretion, elect to refund the purchase price allowable to the part affected, or to issue a credit if the price therefore remains unpaid.

KABA ILCO sells precision-made machines. The buyer assumes all risks, and KABA ILCO shall not be liable for any reason, if the machine has been subjected to improper installation, improper use, improper or inadequate maintenance, negligence, if any unauthorized modification or alteration is made to the machine, or in case of accident. For greater certainty, any machine not operated in accordance with KABA ILCO printed instructions or operated beyond its rated capacity shall not be covered by this or any other warranty.

Any and all warranties made by KABA ILCO on any machine, product, or component thereof shall be effective only if and for so long as the buyer complies with all payment obligations pursuant to the buyer's accepted and acknowledged order. Failure to meet such payment obligations shall void all warranties and not extend the period of time for which such machine, product or component thereof is warranted irrespective of whether or not payment is eventually made.

These warranties are in lieu of and not in addition to any other warranty of condition, expressed or implied, including without limitation merchantability, fitness for a particular purpose or latent defects. The buyer releases KABA ILCO from any liability for any reason other than a breach of its warranties hereunder.

The liability of KABA ILCO shall in no case, including negligence, exceed the purchase price of the defective machine, nor shall KABA ILCO be liable for any personal injuries, property damage or consequential damages.

Use only genuine KABA ILCO replacement parts on this machine!

Serial number : _____

IMPORTANT - Please read carefully before operating machine.

Safety begins with education, and continues with proper application. All personnel who operate your machine should read the supplied Operator's Manual for information on how to properly operate it. The likelihood of accidents and miscuts will be greatly reduced.

General safety

- Safety glasses must be worn to reduce the possibility of eye injury while operating or in the immediate vicinity of key cutting equipment.
- Always turn machine off before making adjustments or inserting or removing keys.
- Machine should be located in an area accessible only by authorized operators. Location must be such that customers and other personnel are not subject to potential injury from "flying chips".
- Do not defeat safety features built into your machine. Removal or modification of safety shields, cutter guards, and other safety devices should be strictly forbidden.
- At no time should the mechanically-driven parts of the machine be touched while it is in operation. The operator should take care to ensure that loose-fitting clothing, long hair, etc. are kept from the area of machine operation.
- Your machine has been specially designed and built for key cutting purposes only and should be operated according to the Operator's Manual. All other uses are strongly discouraged as potentially dangerous, and should not be attempted! Such use will immediately void the machine's warranty.
- Some states have specific age restriction concerning the operation of certain types of equipment. Check local and state ordinances for compliance.

Electrical safety

- (115 Volt models) Your machine is designed to operate using 120 Volt A. C. 60 Hz. electrical current. It is supplied with a three-prong power plug which should be used with a properly grounded three-prong outlet only. Do not defeat the safety purpose of the plug by modifying or using with non-grounded outlets!
- To reduce risk of fire or electrical shock, do not expose or operate machine in damp or wet locations.
- Electrical problems should be referred to qualified repair technicians. If the machine is under warranty, contact KABA ILCO at the address printed on the cover. (KABA ILCO also offers repair service for out-of-warranty machines. Contact KABA ILCO for details.)
- Always unplug the machine before removing the hood or changing the cutter wheel.

Grounding instructions

- In the event of a malfunction or breakdown, grounding provides a path of least resistance for electric current to reduce the risk of electric shock. This machine is equipped with an electric cord that has an equipment-grounding conductor and a grounding plug. The plug must be plugged into a machine outlet that is properly installed and grounded in accordance with all local codes and ordinances.
- Do not modify the plug provided - if it will not fit the outlet, have the proper outlet installed by a qualified electrician.
- Improper connection of the equipment grounding conductor can result in a risk of electric shock. The conductor with insulation that has a green outer surface (with or without yellow stripes) is the equipment-grounding conductor. If repair or replacement of the electric cord or plug is necessary, do not connect the equipment grounding conductor to a live terminal.
- Check with a qualified electrician or service personnel if the grounding instructions are not completely understood, or if in doubt as to whether the machine is properly grounded.
- Use only 3-wire extension cords that have 3-prong grounding plugs and 3-pole receptacles that accept the machine's plug.
- Repair or replace damaged or worn cords immediately.

INTRODUCTION / UNPACKING

Congratulations! You've purchased a superior key cutting machine.

The Model 040 HD Auto/Manual Performance Series key machine you've just purchased is a dual function: 1) it will duplicate keys automatically at the press of a button and 2) it will duplicate keys manually. This dual capability gives you the freedom to select the type of action best suited for the key being duplicated.

The 040 HD is a proven approach to a long time problem in the retail store - how to handle a customer's needs while having to cut keys at the same time. With the 040 HD, the operator can depress a button and walk away, returning later to get the finished key. It will turn waiting time into product time, permitting your people to wait on customers more quickly and to ring up that cash register more frequently.

For those occasions when manual cutting of a key is required, such as a worn or broken key, you can use the 040 HD by operating it as a conventional manual duplicator. There are no complicated or involved procedures to follow for either the manual or the automatic mode.

Featuring exclusive Super Jaw 3 four-way vise jaws, the model 040 HD is designed to accommodate virtually any standard cylinder key without the need for adapters. Even double-sided automotive keys can be duplicated with ease; the four-way jaws include stations ideally suited to gripping these keys and is capable of gripping them in the groove or milling for enhanced clamping performance when necessary. (See illustration on page 11)

UNPACKING INSTRUCTIONS

Your 040 HD key machine has been shipped to you in a sturdy, specially cushioned container to prevent the possibility of damage during handling and shipment. Once the machine is removed from the carton, it should be set up on a level workbench and wiped free of all rustproof-

ing oil. The machine is adjusted at the factory and test keys have been cut on it, but it is recommended that you check the adjustments to make sure they have not slipped or shifted during transit (see page 13 "Adjusting for Depth of Cut").

SAFETY

The 040 HD has been engineered to duplicate cylinder (paracentric) keys. It is not intended or designed for any other purpose. The machine operator assumes all liability when using this machine in a manner inconsistent with its stated design purpose. Refer to page 3 for complete safety information before operating the machine.

KABA ILCO **strongly recommends** the use of protective eye glasses or goggles when operating this machine, or

when in the vicinity of the machine while it is being operated. Protective eye wear prevents injuries! The machine should be turned off before loading or unloading keys.

When the key machine is operating, be careful not to contact the vise jaw or carriage against the cutting wheel as this will cause damage to the cutter, jaw, or carriage.

CAUTION!	DO NOT DESTROY OR DISCARD THIS SPECIAL SHIPPING CARTON. STORE IT CAREFULLY IN A SAFE PLACE. THIS CARTON SHOULD BE USED WHENEVER THE MACHINE IS MOVED OR SHIPPED.
-----------------	---

REPLACEMENTS AND ADJUSTMENTS

REPLACING THE CUTTER

The P-CU20 cutter used on this machine is 2 1/4" in diameter, .250" thick (1/4") and has a 1/2" hole. It's a milling cutter, made out of high speed steel. It has a flat left side, which is excellent for making deep cuts, when these cuts are next to the shoulder, such as on GM, Chicago, etc. No warranty is place on the cutter. Operators should treat it with care and avoid harsh usage. Do not force the carriage up, causing the key blank to bank into the cutter, and do no apply heavy pressure when cutting. Also, do not let the cutter run into the vise jaw; this will dull the cutter quickly.

As with any metal cutting instrument, the P-CU20 will dull with usage. There are three ways to tell when a cutter is dull and required replacing:

1. Time - a dull cutter takes longer to make the cuts.
2. Sound - a dull cutter will emit a shrill sound as it runs across the key blank.
3. Burrs - a dull cutter will not cut away the metal but will roll it away. When this occurs, there will be a buildup of metal burrs on the underside of the key. If this buildup is heavy, the cutter is dull. A sharp cutter leaves little or no burrs.

To replace the cutter, use two wrenches, one 3/4" wrench for the cutter nut and one 1/2" wrench for the cutter shaft. Set the two wrenches in position and loosen the cutter nut. Note that the cutter nut has a reverse thread and turns "downward" to loosen. Remove the spacer washers and the dull cutter. Install the new cutter, the washers and the nut in the order they were removed.

ADJUSTING FOR DEPTH OF CUT

To ensure safety, UNPLUG machine from its power source before adjusting for depth of cut. It's imperative that the key guide and the cutter be in the same plane, that is, aligned to each other. If the cutter guide protrudes further than the cutter, the resulting cuts in a key blank will be too shallow and the duplicate key will not work. Likewise, if the cutter guide is behind the cutter, the cuts in the key will be too deep (see Fig. 8).

To check the depth adjustment, insert two identical key blanks into the vise jaws, setting them flat in each vise. (It is not necessary to align the blanks.) Then, raise the carriage, positioning the left blank against the cutter guide and the right blank against the cutter. Next, turn the machine pulley by hand and note the right key blank. The cutter should just barely graze the key blank when the adjustment is correct.

No cutter is perfectly round so make one complete rotation

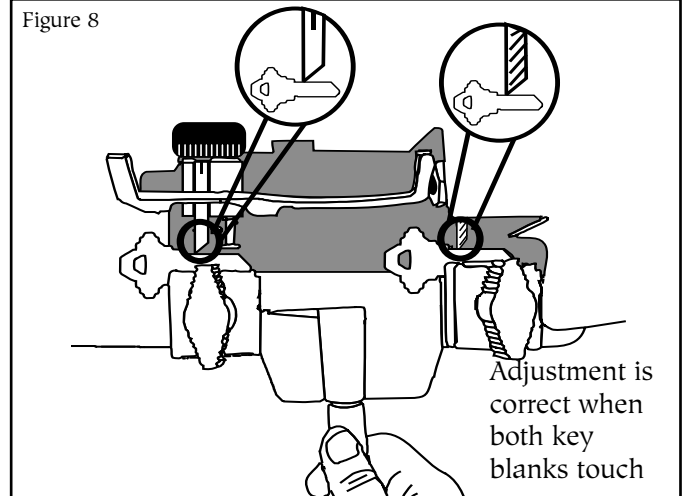

of the cutter before changing adjustment. There will be a high point on the cutter; the adjustment should be made to the high point. If the cutter does not touch the key blank after one rotation, proceed to change the adjustment.

To adjust the cutter guide, loosen the binding screw on

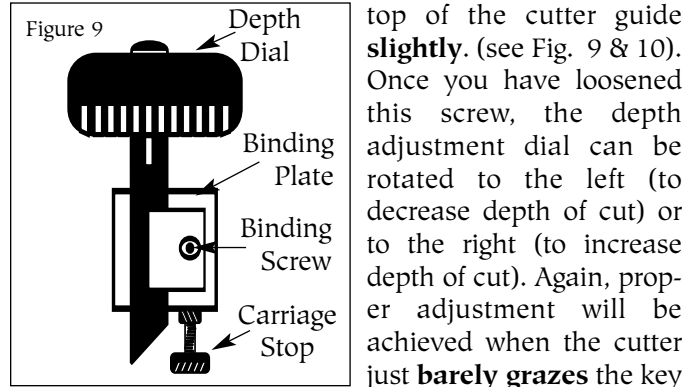

top of the cutter guide **slightly**. (see Fig. 9 & 10). Once you have loosened this screw, the depth adjustment dial can be rotated to the left (to decrease depth of cut) or to the right (to increase depth of cut). Again, proper adjustment will be achieved when the cutter just **barely grazes** the key

blank before it while the cutter guide is in contact with the other key blank. Retighten the binding screw once the calibration process is completed. Recheck after tightening to assure that adjustment did not shift.

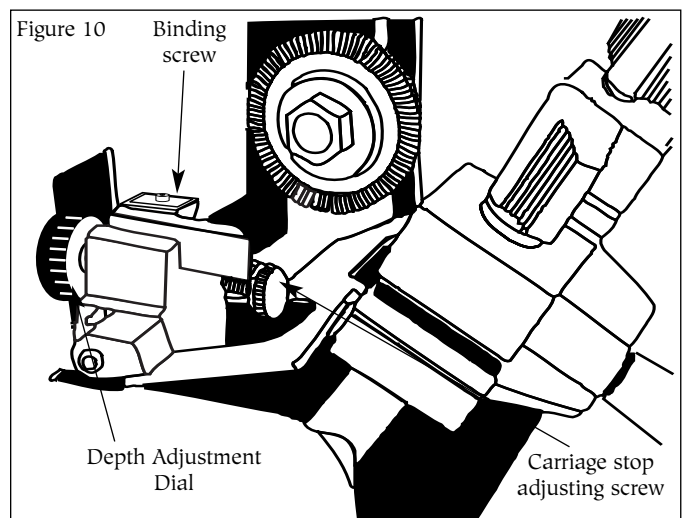

THE CUTTING OPERATION

9. Move the carriage to line up the cutter guide with the shoulder of the pattern key, then shift slightly away from the shoulder. Do not permit the cutter to touch the shoulder of the key blank.
10. Press in on the carriage, while guiding it to the left. Carefully trace the cuts of the pattern key with the cutter guide. The cutter will make corresponding cuts in the key blank.
11. When the cut closest to the tip of the pattern key has been traced, retrace the cuts by guiding the carriage to the right. This will clear away any metal not removed on the initial pass over the key blank.

DUPLICATING PROCEDURE - Automatic Mode

WARNING: Do not install or remove keys unless the off/on switch is in the off position.

1. Install the pattern key and key blank in the vise jaws as described in steps 1-6 of "Manual Mode".
2. Slide the carriage all the way to the right.
3. Press the off/on power switch to its "on" position.
4. Pull down on the carriage handle while pulling out on the carriage trigger (Fig. 7). This will enable the carriage tension spring to lift the carriage into cutting position. (EASE the carriage into cutting position. DO NOT allow it so "slam" forward.) Once eased into position, remove your hand from the carriage handle; the

Figure 7

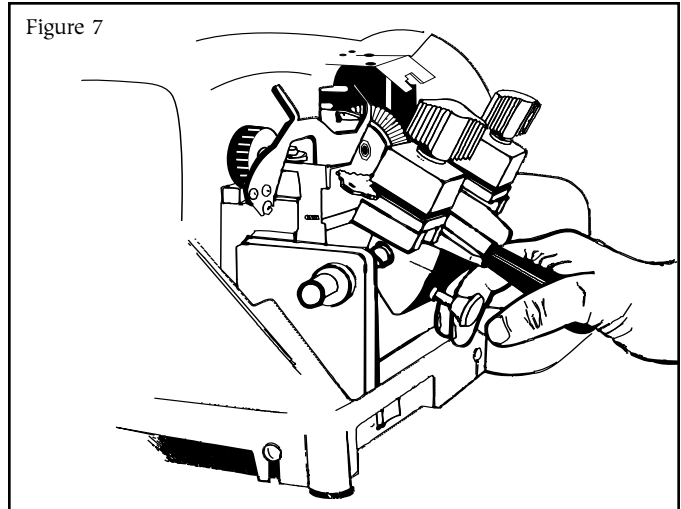

carriage spring will supply the necessary pressure to cut a key.

5. Depress the auto start switch and hold it depressed for a least two seconds. The drive motor will start and the carriage will begin moving to the left.
6. The carriage will make only one pass in front of the cutter. When it has completed this pass, the drive motor will turn off.
7. Press the off/on power switch to its "off" position.
8. Pull down on the carriage handle to lower the carriage. When the carriage snaps into its latched position, remove the cut key from the right vise jaw.
9. Depress the off/on power switch, which will cause the demurring brush and cutter to rotate. Press the cut key against the rotating brush to remove any burrs of chips that may be present.

Figure 4

Super Jaw 3 vise jaw shown gripping a typical automotive key

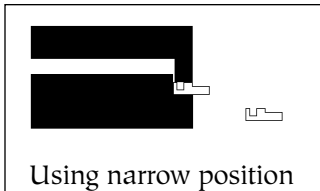
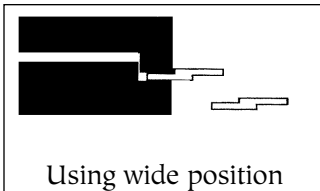
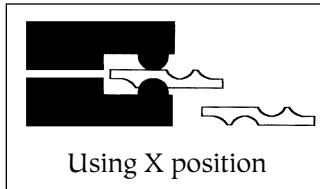
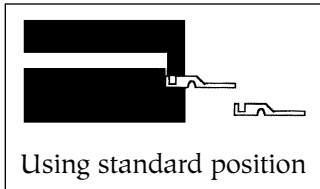
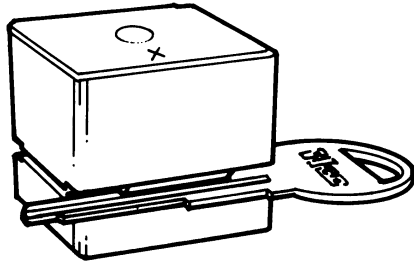

GENERAL OPERATING SEQUENCE

WARNING: Do not install or remove keys unless the off/on switch is in the off position.

The 040 HD key machine can be used in either a manual or automatic mode simply by altering steps in the operating procedure. For either manual or automatic operation, the pattern key and blank key are loaded using the same steps.

To duplicate keys using the manual mode, press the off/on switch to the "ON" position. Then the cutting operation is performed with the operator holding the carriage up to the cutter guide and cutter while moving the carriage sideways. The cutting operation should begin at the cut closest to the head of the key with the operator carefully tracing each cut in turn until they have traced the cut closest to the tip.

To duplicate using the automatic mode, load the pattern and blank key, then pull down on the carriage while pulling out on the carriage trigger. This will enable the operator to ease the carriage up into cutting position with cutting pressure automatically applied. With the off/on switch in the auto position, the cutting operation will begin once the automatic actuator switch is depressed.

DUPLICATING PROCEDURE - Manual Mode

WARNING: Do not install or remove keys unless the off/on switch is in the off position.

Use this procedure when the manual mode is selected:

1. Slide the carriage to its extreme right position.
2. Rotate both vise jaws to the station suitable for the key being duplicated.
3. Insert the blank key in the right vise and tighten the wing nut. Be sure the key is laying flat in the vise jaw and is not tilted up or down.
4. Lower the key gauge and move the blank key so that the shoulder of the key contacts the right finger of the key gauge. Leave the key gauge in this position (Fig. 5)

Figure 5

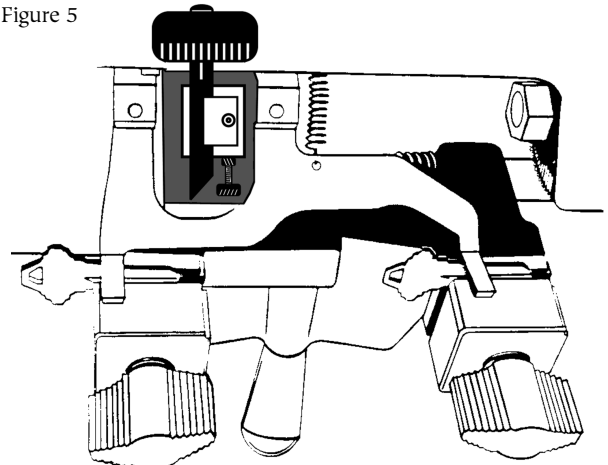

Aligning Shoulder of Keys with Key Gauge

5. Insert the pattern key into the left vise jaw, pushing it into the jaw until its shoulder butts against the left finger of the key gauge. Tighten the wing nut to secure the pattern key.
6. Lift the key gauge to its up position.
7. Press the off/on switch to the "manual" position.
8. Lift the carriage with both hands (Fig 6.)

Figure 6

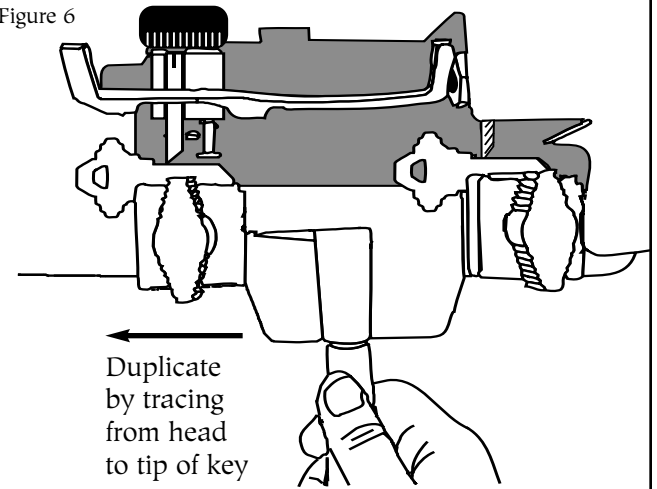

HOW TO DUPLICATE KEYS

ALIGNING KEYS IN THE VISE JAWS

Both the pattern key and key blank must be aligned to each other and must be securely clamped in the vise jaws. To do this, slide the machine carriage towards the right and clamp the appropriate blank key in the right jaw and tighten the wing nut (Do NOT over-tighten). Lower the key gauge and position the blank key so the shoulder of the key contacts the left side of the right hand key gauge finger (See Fig. 1). Insert the pattern key in the left vise jaw until its shoulder contacts the left key gauge finger. Tighten the wing nut (do NOT over-tighten). You can now proceed to cut.

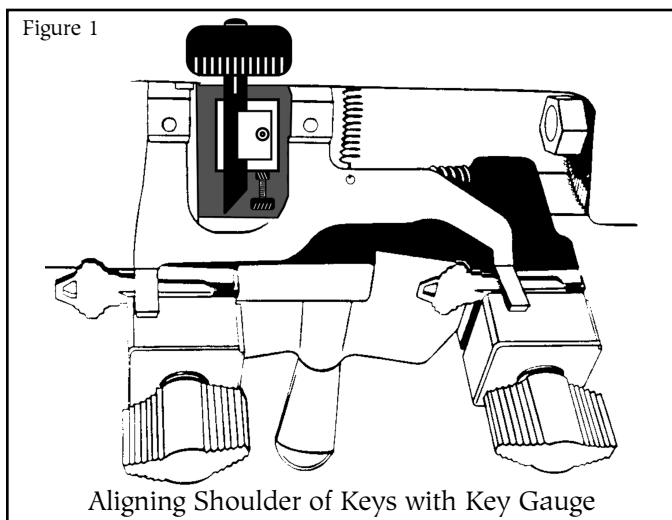

On keys such as the Ford double-sided key, which do not have conventional shoulder, the tip of the key is used as the aligning point (see Fig. 2). Clamp the blank key in first and move the machine carriage to the left. Lower the key gauge and position the carriage so the tip of the blank key touches the key gauge. Install and align the pattern key in the left vise jaw in the same manner.

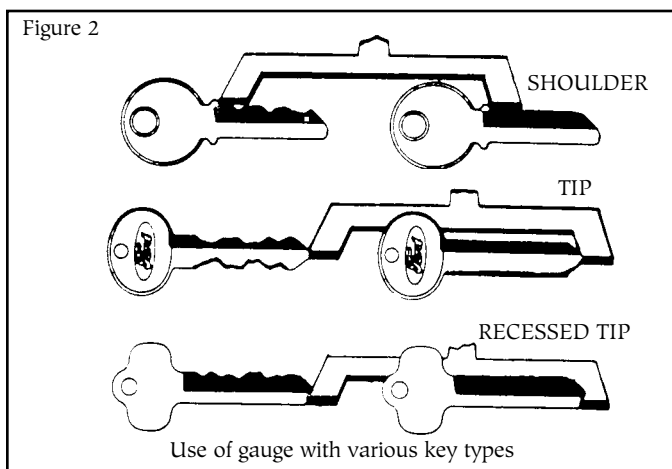

"Best" and "Falcon" type keys do not have a conventional shoulder but have a recessed tip and the key gauge is used to align the recessed tips. After clamping the blank key, the carriage is moved to the left so that the key gauge can be lowered to contact the recessed tip surface. The pattern key is aligned in the left vise jaw and positioned to contact the edge of the key gauge in the same manner.

USING THE SUPER JAW 3 FOUR-WAY VISE JAWS

Your 040 HD is equipped with the KABA ILCO versatile Four-way, Super Jaw 3 vise jaws. They feature four unique clamping surfaces to securely grip virtually any typical cylinder key (see Fig. 3).

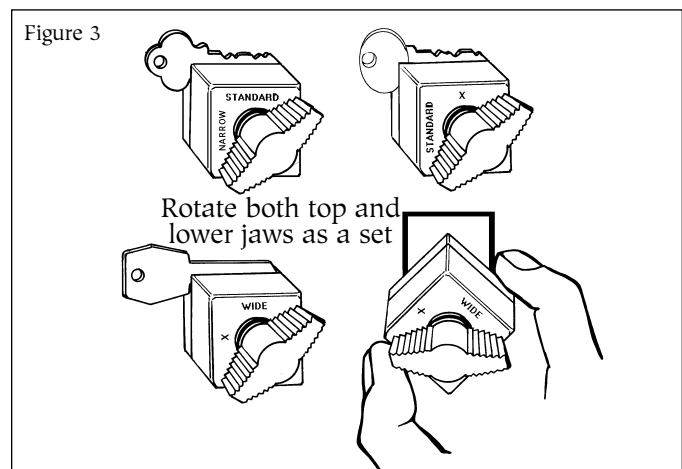

Standard - for holding regular cylinder keys, such as house keys, single-sided automotive keys, padlock keys, with one or two shoulders.

Narrow - for holding the 1092B and other narrow width keys.

Wide - for holding the Ford double-sided keys and similar types, either primary or secondary. When positioning the keys in the vise jaws, lay the key so that its center ledge is flat against the top surface of the jaw.

X - Ideal for holding most double-sided convenience keys used on most current automobiles. Grip these keys by the grooves rather than the blade edge where the cuts are located (see Fig. 4 on next page).

To reposition the vise jaws, as from Standard to Wide, first loosen the wing nuts. Then lift upward on the top and bottom of each vise jaw as a complete unit to raise them above their seat in the carriage. Rotate the jaws until the chosen vise position is facing toward the rear of the machine and lower the jaws back into contact with the carriage. Both left and right vise jaws should be rotated to the same position.

OPERATING HANDLES

The 040 HD key machine is shipped completely assembled except for the carriage handle. Upon unpacking the machine, locate the handle and thread it into the carriage. Note that the handle threads into the carriage in the area directly above the trigger assembly. Then, cut the nylon band holding the carriage rigid and let the carriage drop to its down position. At this point, you should be able to slide the carriage right to left easily. If there is any binding that prevents the carriage from sliding sideways, do NOT force the carriage. Instead, plug in the power cord and depress the ON button to start the cutter rotating. This will relocate the automatic cam (which may have been creating the binding action) to the starting position and thus free the carriage.

TEST KEYS

A series of cut keys are supplied with your machine. These keys were cut on your machine and represent the result of our quality inspectors' work before approving your machine for shipment. The keys are reproductions of factory dimensioned pattern keys and are accurate to .002" or less. Save these keys and use them as standards to check the accuracy of cuts in the keys you make. By measuring across the cuts with a micrometer, you'll be able to see if your machine is cutting too deep or too shallow thus indicating that an adjustment of the key guide is necessary.

PROPER KEY CUTTING TECHNIQUES

Even though your 040 HD key machine is designed to make key cutting fast, efficient and accurate, operator skill is important. The actual mechanics of placing keys within the vise jaws is simple to learn, but there are some basics that must be followed. A properly adjusted key machine used by someone who ignores good key cutting techniques will **NOT** produce a good key. The way a person clamps a key into the vise jaws is critical to the accuracy of the duplicated key.

Remember - the real purpose of a duplicate key is to operate the lock for which it was intended. If customers return keys, you should re-examine your cutting techniques and adjustment of the machine.

Here are some important operating tips:

1. Vise jaws - clean them regularly so that no metal chips lie under the keys. **It is essential that both keys lie flat across the entire width of each vise jaw. Neither key should be tilted.**
2. Do NOT use pliers or other tools to tighten the vise jaws. Firm hand pressure is sufficient.
3. Keep the carriage shaft free of metal chips. A thin film of oil can be applied to it. The carriage should be free to move without binding.
4. NEVER touch the shoulder of a key to the side of the

cutter guide. This will cause the shoulder of the key blank to touch the side of the cutting wheel. When this happens, some of the metal will be cut away from the shoulder of the key blank. If the resulting duplicated key is duplicated two, three, four times over, an error will accumulate and cause a non-operating key. Do not grind away the shoulder.

5. Don't run the cutter into the vise jaw; this will dull the cutter, and reduce cutter efficiency.
6. Keep the cutter clean. Don't let any foreign objects or instruments blunt it. This cutter is a precise cutting tool and should be handled with care.
7. Lubrication requirements for your new "HD" Performance Series key machine are minimized through the use of sealed, permanently lubricated cutter spindle bearings. The carriage shaft however, should be inspected on a routine basis, and wiped with a dry, clean cloth to remove any chip buildup that occurs. After cleaning, application of a dry film lubricant is recommended for maximum service life; spray type lubricants that dry completely once applied are fine. Depending on usage, the machine's 1/4 hp motor may require lubrication once annually. Refer to the label on the motor for lubrication details and recommended interval.

EXPLODED VIEW PARTS LIST

Refer to pages 6-7 for illustration

Ref.	Part no.	Description	Ref.	Part no.	Description
1	040HD-1	Carriage	87	040HD-87	Safety shield
1X	040HD-1X	Carriage assembly	90	025-90	Nut, #10-32
2	025-2	Carriage stud	91	040-91	Power cord
3X	045HD-3X	Vise jaw assembly (Super Jaw 3)	92	040-92	motor cable
4	025-4	Vise jaw spring	98	040-98	Cam motor screws
6X	025-6X	Thrust bearing set	100	040HD-100	Cutter spacer; right
8	025-8	Wing nut	101	025-101	Set screw, 1/4-20x1/4"
9X	040-9X	Carriage handle	106	040-106	Chip tray
11	040-11	Trigger Pin	108	040-108	Carriage Bumper
11X	040-11X	Trigger Assembly	109	025-109	Bearing washer
16	040-16	Carriage torsion spring	110	025-110	Wave washer
17	025-17	Washer	123	040-123	Screw, #4-40x1/2"
18	025-18	Screw. 10-32 x 1/2"	129	040-129	Locking nut (8-32)
20	040HD-20	Cutter shaft bearings	135	040-135	Cam
21	025-21	Carriage shaft bushing, right	137	040-137	Set screw, #10-32 x 3/16"
22	040-22	Carriage shaft bushing, left	138	040-138	Gear motor (115V)
23	040HD-23	Carriage shaft	140	040-140	Gear motor cam
24	040-24	Friction Reducer	141A	040-141A	Micro switch plate
36	025-36	Cutter nut, N-4	144	040HD-144	Automatic cycle switch
37	025-37	Cutter spacer; left	146	040-146	Strain relief for power cord
38	P-CU20	P-CU20 cutter	150	040-150	Switch screw (6-32 x 1/4")
40	040HD-40	Cutter shaft	151	040-151	Set screw (8-32 x 3/8")
41	040HD-41	Cutter shaft pulley (2")	153	040HD-153	Switch panel label
43	025-43	Nylon brush	158	040-158	Key gauge label
45	025-45	Brush bolt washer, 5/16"	160	025-160	Caution label
46A	025-46A	Hex head screw, 5/16-18 x 3/4"	161	040-161	Key Gauge guard
47	025-47	Motor pulley 2" - 3L	162	040-162	Key Gauge guard Screws
48	040HD-48	V-Belt, 3L160	163	045-163	Hood Screw
49	040-49	Cutter guide (stylus)	164	040-164	Cam follower block
50	040-50	Carriage stop	165	040-165	3932 x 1/2 dowel pin
52	040-52	Socket hd. screw 8-32 x 1-1/2"	166	044-166	Cam follower pin
53	040-53A	Cutter guide binding plate	169	040-169	Carriage Label
54	045-54	Cutter guide binding screw	171	025-171	Cutter pulley set screw, 3/8" -18
55	045-55A	Adjusting screw	181	024B-181	Key Gauge Spacer - Left
56	040-56	Key gauge	183	040-183	1/4-20 Lockwasher
58	040-58	Key gauge dowel pin	184	040-184	1/4-20 Hex Nut
59	025-59	Key gauge housing	186	045-186	6-32 x 3/8" set screw
60	025-60	Cap screw, 8-32 x 1/2"	187	045-187	dowel
62	025-62A	On/Off switch	188	045-188	dowel spring
65	040HD-65	Base machined	189	045-189	Adjustment dial
68	040-68	Electrical cover	190	045-190	Cutter guide label
69	040-69	Set Screw 10-24 x 3/8"	191	040-191	Switch plate (adjustable)
70	040-70	Rubber mount	192	040-192	Switch plate screws
74	040-74	Truss head screw, 8-32	193	040-193	Switch plate washer
75	040-75	Motor, 1/4hp, 115V C/S	194	045-194	#10 flat washer
79	040-79	Key gauge spring	195	045-195	10-32 x 1/2" Button hd. screw
84	024B-84	Crescent ring	NS	040HD-IM	040 HD Instruction Manual
86X	040HD-86X	Safety hood assembly			

EXPLODED VIEW

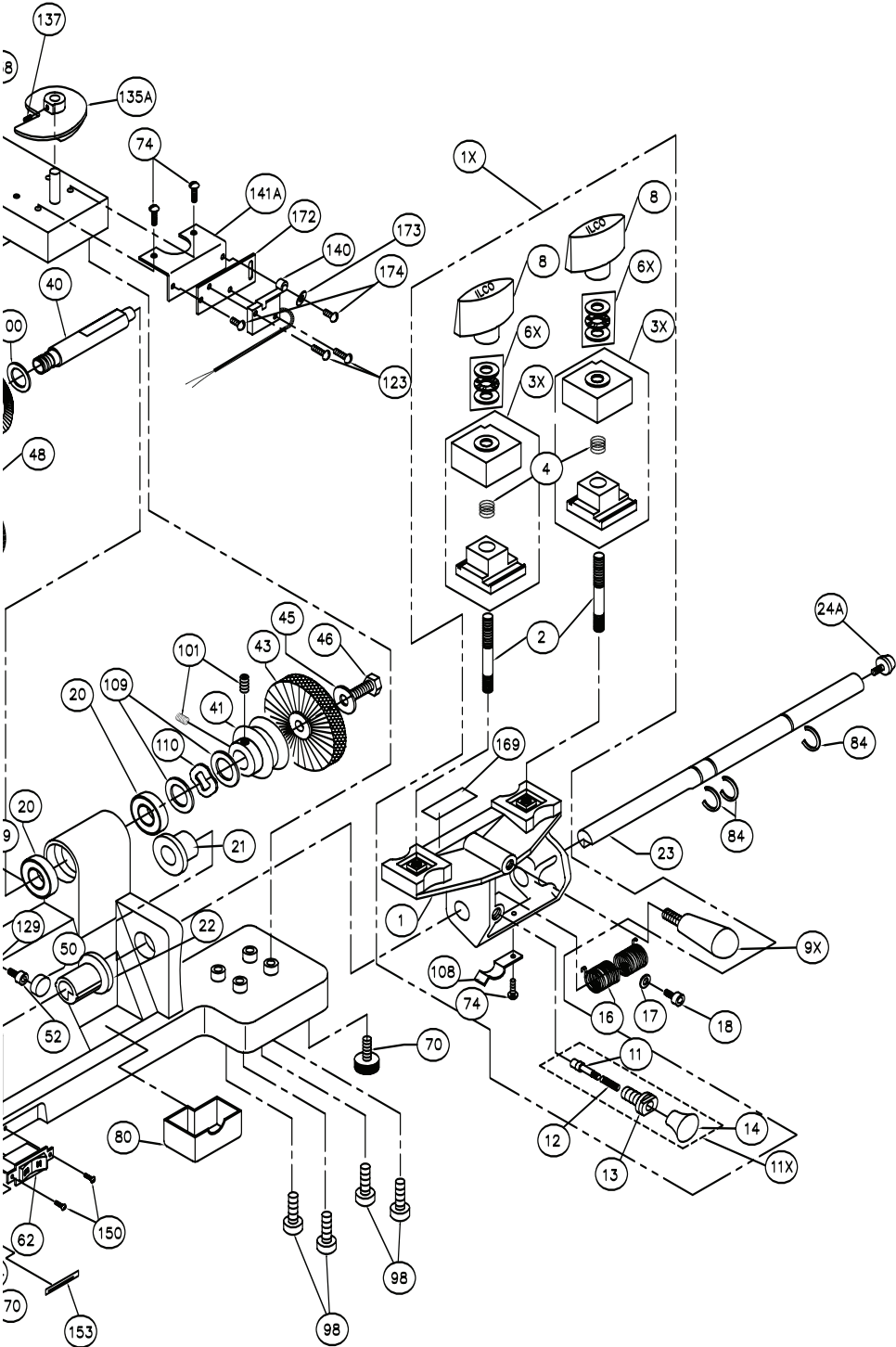

EXPLODED VIEW

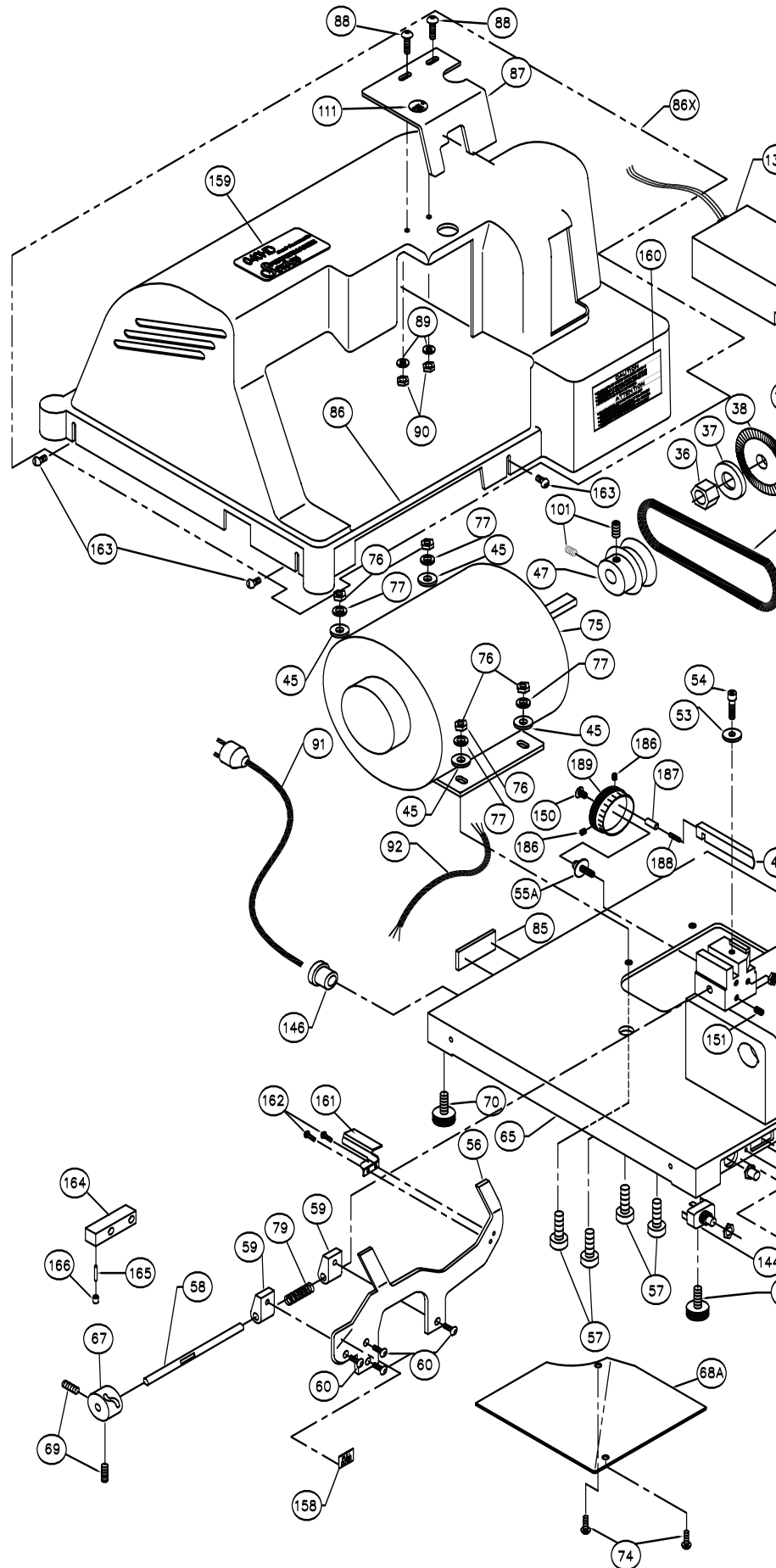

OPERATING PARTS

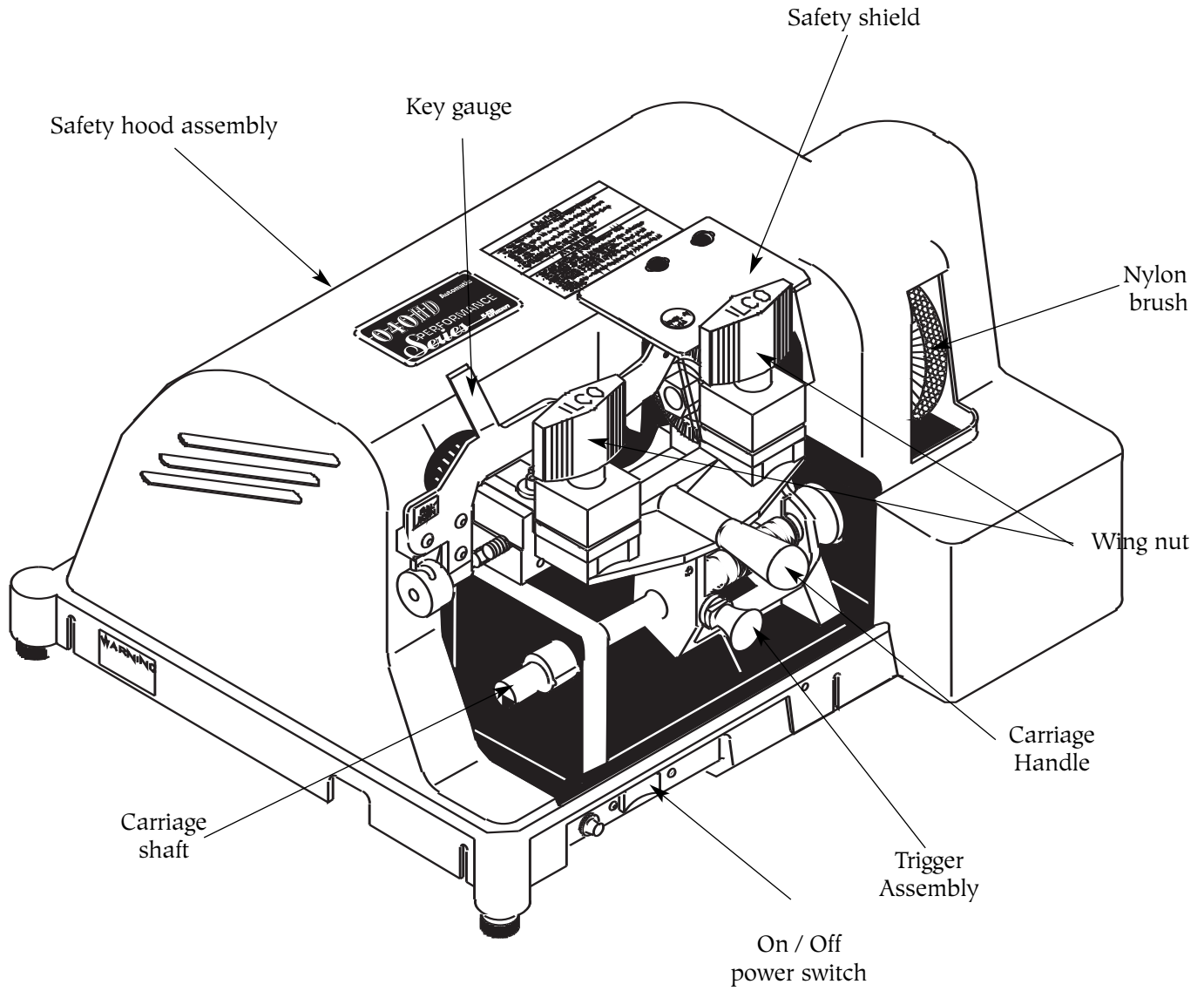

Operating Parts Identification

Part no.	Identification
040-1 025-3X 025-8	Carriage Vise jaw assembly Wing nut
040-9X 040-11X 040-23	Carriage Handle Trigger Carriage shaft
CU20 814-00-51 040-49A	P-CU20 cutter Nylon brush Cutter guide (stylus)
040-50 040-56 040-62	Carriage Stop Key gauge On/Off power switch
040-86X 040-87A 040-144	Safety hood assembly Safety shield Auto Start Switch

REPLACEMENTS AND ADJUSTMENTS

Each calibration mark on the depth adjustment dial is equivalent to approx. .0015" (1 1/2 thousandths of an inch). As you can see, this system can allow for very precise adjustment of your new key machine. In fact, if you have a key micrometer or dial caliper available, you can adjust your machine with "factory accuracy". To do this, you would simply duplicate a key and measure cuts on both the "pattern key" and the duplicate key for comparison. This would show any deviation that existed and whether the duplicate cuts were too deep or too shallow and by how much. With this information, you can use the depth adjustment dial on your machine to calibrate your machine for best possible accuracy. This is very important as many locks are designed with close fit tolerances and the keys you duplicate are often themselves copies; functional but just barely so. The more accurate your key machine is adjusted, the closer your duplicates will match their originals, resulting in fewer non-functional miscuts!

It is very important to understand that adjusting your machine is not a "one time" procedure. As the cutter on your machine wears down, the machine must be adjusted to compensate. It is good shop practice to **check** your machines' depth adjustment every 2-4 weeks, based upon your store's key cutting volume and readjust as necessary. You will find that re-calibration is seldom needed, but by checking and correcting **BEFORE** customers begin returning miscut keys, you will create a reputation for your store as a "good place" to have keys duplicated.

ADJUSTING FOR SPACING

There is no adjustment for spacing. However, if a key gauge assembly is ever replaced, the key gauge must be fitted to the machine after it has been installed. To do this, first install a pattern key and key blank and align these against the cutter guide and cutter. Then lower the key gauge and file the appropriate finger of the gauge to allow contact with the shoulder of both keys.

ADJUST THE CARRIAGE STOP

The purpose of the carriage stop is to prevent the cutter from hitting into the right vise jaw. The stop is a nut and bolt and is adjustable. To check the adjustment, raise carriage (without keys in vise jaws) and rotate the cutter by hand. The cutter should not contact the vise jaw. When the carriage stop is properly adjusted, there should be a space of .008" between the vise jaw and the cutter (this is about the thickness of an ordinary business card). Do not allow a greater distance since this may affect the depth of cut.

CLEANING

Your machine should be kept clean of all filings and dust. The most critical areas are the carriage jaws and shafts. A one inch paint brush is ideal to brush these areas of the machine. The shafts should be wiped periodically with a lightly oiled cloth. We suggest brushing the jaws often as even a single filing can alter the accuracy of the machine.



A Member of the Kaba Group

Kaba Ilco Corp.

P O Box 2627 (27802)

400 Jeffreys Rd., Rocky Mount, NC 27804

Tel.: (252) 446-3321 • Fax: (252) 446-4702

www.kaba-ilco.com