

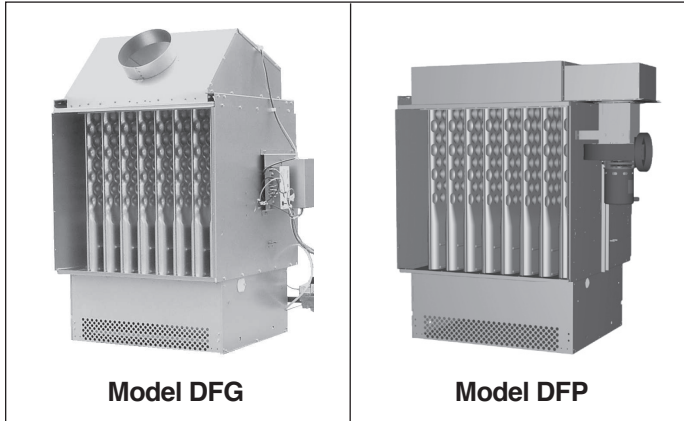

5-564.1
5H0806370001

August, 2015

INSTALLATION AND SERVICE MANUAL gas-fired indoor gravity and power vented duct furnaces models DFG and DFP



Intertek

DFP models are approved for use in California by the CEC.

FOR YOUR SAFETY

IF YOU SMELL GAS:

1. Open windows.
2. Don't touch electrical switches.
3. Extinguish any open flame.
4. Immediately call your gas supplier.

FOR YOUR SAFETY

The use and storage of gasoline or other flammable vapors and liquids in open containers in the vicinity of this appliance is hazardous.

⚠ WARNING

1. Improper installation, adjustment, alteration, service or maintenance can cause property damage, injury or death, and could cause exposure to substances which have been determined by various state agencies to cause cancer, birth defects or other reproductive harm. Read the installation, operating and maintenance instructions thoroughly before installing or servicing this equipment.
2. Installing, starting up and servicing heating, ventilation and air conditioning equipment poses significant hazards and requires specialized knowledge of Modine products and training in performing those services. Failure to have any service properly performed by, or making any modification to Modine equipment without the use of, qualified service personnel could result in serious injury to person and property, including death. Therefore, only qualified service personnel should work on any Modine products.

⚠ CAUTION

To prevent premature heat exchanger failure do not locate ANY gas-fired units in areas where chlorinated, halogenated, or acid vapors are present in the atmosphere.

Inspection on Arrival

1. Inspect unit upon arrival. In case of damage, report it immediately to transportation company and your local factory sales representative.
2. Check rating plate on unit to verify that power supply meets available electric power at the point of installation.
3. Inspect unit upon arrival for conformance with description of product ordered (including specifications where applicable).

THIS MANUAL IS THE PROPERTY OF THE OWNER.
PLEASE BE SURE TO LEAVE IT WITH THE OWNER WHEN YOU LEAVE THE JOB.

SPECIAL PRECAUTIONS / TABLE OF CONTENTS

SPECIAL PRECAUTIONS

THE INSTALLATION AND MAINTENANCE INSTRUCTIONS IN THIS MANUAL MUST BE FOLLOWED TO PROVIDE SAFE, EFFICIENT AND TROUBLE-FREE OPERATION. IN ADDITION, PARTICULAR CARE MUST BE EXERCISED REGARDING THE SPECIAL PRECAUTIONS LISTED BELOW. FAILURE TO PROPERLY ADDRESS THESE CRITICAL AREAS COULD RESULT IN PROPERTY DAMAGE OR LOSS, PERSONAL INJURY, OR DEATH. THESE INSTRUCTIONS ARE SUBJECT TO ANY MORE RESTRICTIVE LOCAL OR NATIONAL CODES.

HAZARD INTENSITY LEVELS

1. **DANGER:** Indicates an imminently hazardous situation which, if not avoided, WILL result in death or serious injury.
2. **WARNING:** Indicates a potentially hazardous situation which, if not avoided, COULD result in death or serious injury.
3. **CAUTION:** Indicates a potentially hazardous situation which, if not avoided, MAY result in minor or moderate injury.
4. **IMPORTANT:** Indicates a situation which, if not avoided, MAY result in a potential safety concern.

DANGER

Appliances must not be installed where they may be exposed to a potentially explosive or flammable atmosphere.

WARNING

1. Gas fired heating equipment must be vented - do not operate unvented.
2. a. Model DFG has a built-in draft diverter - additional external diverters are not required or permitted.
b. Model DFP has a built-in power exhaustor - additional external power exhaustors are not required or permitted.
3. If you are replacing an existing heater, it may be necessary to resize the venting systems. Improperly sized venting systems can result in vent gas leakage or the formation of condensate. Refer to the National Fuel Gas Code ANSI Z223.1 or CSA B149.1 latest edition. Failure to follow these instructions can result in injury or death.
4. For Model DFG, gas-fired heating equipment which has been improperly vented, or which experiences a blocked vent condition may have flue gases accidentally spilled into the heated space. See page 22 for specific information about the blocked vent safety switch supplied on the unit.
5. For Model DFP, under no circumstances should two sections of double wall vent pipe be joined together within one horizontal vent system due to the inability to verify complete seal of inner pipes.
6. All field gas piping must be pressure/leak tested prior to operation. Never use an open flame. Use a soap solution or equivalent for testing.
7. Gas pressure to appliance controls must never exceed 14" W.C. (1/2 psi).
8. Disconnect power supply before making wiring connections to prevent electrical shock and equipment damage.
9. All appliances must be wired strictly in accordance with wiring diagram furnished with the appliance. Any wiring different from the wiring diagram could result in a hazard to persons and property.
10. To reduce the opportunity for condensation, the minimum sea level input to the appliance, as indicated on the serial plate, must not be less than 5% below the rated input, or 5% below the minimum rated input of dual rated units.
11. Ensure that the supply voltage to the appliance, as indicated on the serial plate, is not 5% greater than the rated voltage.
12. Any original factory wiring that requires replacement must be replaced with wiring material having a temperature rating of at least 105°C.
13. When servicing or repairing this equipment, use only factory-approved service replacement parts. A complete replacement parts list may be obtained by contacting Modine Manufacturing Company. Refer to the rating plate on the appliance for complete appliance model number, serial number, and company address. Any substitution of parts or controls not approved by the factory will be at the owners risk.

CAUTION

1. Purging of air from gas lines should be performed as described in ANSI Z223.1 - latest edition "National Fuel Gas Code", or in Canada in CAN/CGA-B149 codes.
2. Do not attempt to reuse any mechanical or electrical controllers which have been wet. Replace defective controller.
3. Ensure that the supply voltage to the application, as indicated on the serial plate, is not 5% less than the rated voltage.

IMPORTANT

1. To prevent premature heat exchanger failure, do not locate ANY gas-fired appliances in areas where corrosive vapors (i.e. chlorinated, halogenated or acid) are present in the atmosphere.
2. To prevent premature heat exchanger failure, the input to the appliance, as indicated on the serial plate, must not exceed the rated input by more than 5%.
3. To prevent premature heat exchanger failure, observe heat exchanger tubes by looking at the heat exchanger through field installed access openings in connecting ductwork. If the bottom of the tubes become red while blower and duct furnace are in operation, additional baffles must be inserted between blower and duct furnace to assure uniform air flow across the heat exchanger.
4. To prevent premature heat exchanger failure, with all control systems, a blower starting mechanism must be provided so that the blower is running or energized within 45 seconds of the gas control operation.
5. Start-up and adjustment procedures should be performed by a qualified service agency.
6. To check most of the Possible Remedies in the troubleshooting guide listed in Table 20.1, refer to the applicable sections of the manual.

Table of Contents

Inspection on Arrival	1
Special Precautions	2
SI (Metric) Conversion Factors	3
Unit Location	3
Location Recommendations	3
Combustible Material and Service Clearances	3
Combustion Air Requirements	3
Unit Suspension	4
Installation	4
Direction of Airflow	4
Air Distribution Baffle Removal	4
Duct Installation and Airflow Distribution	4-5
Venting	5-7
Gas Connections	8
Considerations for Elevation	9
Electrical Connections	10
Start-Up Procedure	10
Pilot Burner and Main Burner Adjustment	11
Air Shutter Adjustment	12
Control Operating Sequence	12-13
Variable Air Movement Applications	13
Options	14
Performance	15
Air Temperature Rise Limits	15
Recommended Unit Configurations	15
Pressure Drop Curves	15
Dimensional Data	16-17
Maintenance	18-19
Service & Troubleshooting	20-22
Replacement Parts Ordering	23
Model Identification	24
Commercial Warranty	Back Page

SI (METRIC) CONVERSION FACTORS / UNIT LOCATION

SI (METRIC) CONVERSION FACTORS

Table 3.1

To Convert	Multiply By	To Obtain	To Convert	Multiply By	To Obtain
"W.C.	0.24	kPa	CFH	1.699	m ³ /min
psig	6.893	kPa	Btu/ft ³	0.0374	mJ/m ³
°F	(°F-32) x 0.555	°C	pound	0.453	kg
inches	25.4	mm	Btu/hr	0.000293	kW/hr
feet	0.305	meters	gallons	3.785	liters
CFM	0.028	m ³ /min	psig	27.7	"W.C.

UNIT LOCATION

! DANGER

Appliances must not be installed where they may be exposed to a potentially explosive or flammable atmosphere.

IMPORTANT

To prevent premature heat exchanger failure, do not locate ANY gas-fired appliances in areas where corrosive vapors (i.e. chlorinated, halogenated or acid) are present in the atmosphere.

Location Recommendations

- When locating the furnace, consider general space and heating requirements, availability of gas and electrical supply, and proximity to vent locations.
- Unit must be installed on the positive pressure side of the circulating blower.
- Be sure the structural support at the unit location site is adequate to support the weight of the unit. For proper operation the unit must be installed in a level horizontal position.
- Do not install units in locations where the flue products can be drawn into the adjacent building openings such as windows, fresh air intakes, etc.
- Be sure that the minimum clearances to combustible materials and recommended service clearances are maintained. Units are designed for installation on non-combustible surfaces with the minimum clearances shown in Figure 3.1 and Tables 3.2 and 3.3.
- Units installed downstream of refrigeration systems, or exposed to inlet air temperatures of 40°F or less, may experience condensation, therefore, provisions should be made for disposal of condensate. Means have been provided in the bottom pan of the unit to accommodate a condensate drain line connection flange.
- When locating units, it is important to consider that the exhaust vent piping must be connected to the outside atmosphere.
- In garages or other sections of aircraft hangars such as offices and shops which communicate with areas used for servicing or storage, keep the bottom of the unit at least 7" above the floor. In public garages, the unit must be installed in accordance with the Standard for Parking Structures NFPA #88A and the Standard for Repair Garages NFPA #88B. In Canada, installation of unit heaters in airplane hangars must be in accordance with the requirements of the enforcing authority, and in public garages in accordance with the current CAN/CGA-B149 codes.
- Do not install units in locations where gas ignition system is exposed to water spray, rain, or dripping water.

Figure 3.1 - Combustible Material and Service Clearances

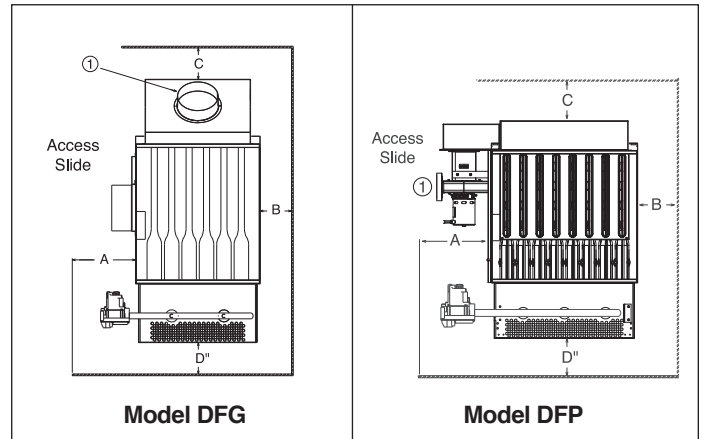

① A 3" minimum clearance to combustible material is required from the vent collar.

Table 3.2 - Combustible Material Clearances

Model Size	Access Side (A)		Non-Access Side (B)	Top (C)		Bottom (D)
	DFG	DFP	All	DFG	DFP	All
75 thru 175	6"	12"	1"	2"	3"	2"
200 thru 400	6"	12"	2"	2"	3"	2"

Table 3.3 - Recommended Service Clearances

Model Size	Access Side (A)	Non-Access Side (B)	Top (C)	Bottom (D)
75	18"	6"	10"	0"
100/125	20"			
150/175	25"			
200/225	27"			
250/300	30"			
350/400	41"			

Combustion Air Requirements

Units installed in tightly sealed buildings or confined spaces must be provided with two permanent openings, one near the top of the confined space and one near the bottom. Each opening should have a free area of not less than one square inch per 1,000 BTU per hour of the total input rating off all units in the enclosure, freely communicating with interior areas having, in turn adequate infiltration from the outside. For further details on supplying combustion air to a confined (tightly sealed) space or unconfined space, see the National Fuel Gas Code ANSI Z223.1 of CAN/CGA B149.1 or .2 Installation Code, latest edition.

UNIT SUSPENSION / INSTALLATION

UNIT SUSPENSION

Be sure the means of suspension is adequate to support the weight of the unit (see Dimensional Data for unit weights). For proper operation, the unit must be installed in a level horizontal position. Combustible material and service clearances as specified in Figure 3.1 and Tables 3.2 and 3.3 must be strictly maintained.

1. Four 1/2" - 13NC tapped holes in top of furnace are provided to accept ceiling hangers. To assure that flames are directed into the center of the heat exchanger tubes, the furnace must be supported in a vertical position. Use a spirit level to ensure that unit is suspended correctly.
2. NOTE: A pipe hanger adapter kit, shown in Figure 4.1, is available as an accessory. One kit consists of two drilled 3/4" IPS pipe caps and two 1/2 - 13 x 1-3/4" capscrews to facilitate threaded pipe suspension. Two kits are required for mounting all duct furnace models.

Figure 4.1 - Suspension Methods

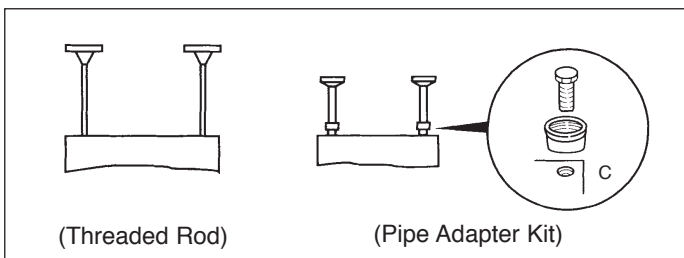

INSTALLATION

Direction of Airflow

Select proper direction of airflow. The air baffle must face the air inlet direction as shown in Figure 4.2. If it is necessary to reverse the airflow direction, remove the four screws securing the air distribution baffle, reverse the air distribution baffle to the air inlet side and replace the screws. See Airflow Reversal Note.

Figure 4.2 - Air Distribution Baffle Location

Baffle location shown on entering air side of duct furnace.

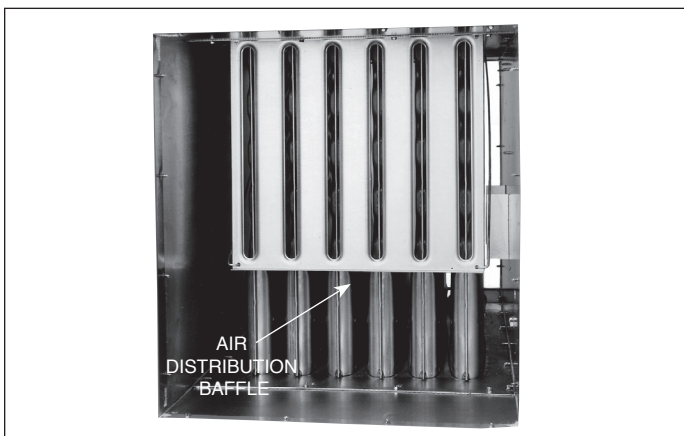

Airflow Reversal Note: If factory installed discharge air options (thermostat, freeze protection, etc.) were provided, these options would have to be relocated to the discharge air side of the duct furnace.

Air Distribution Baffle Removal

The duct furnaces are supplied with a factory installed air baffle. For applications where an air temperature rise less than 60°F is desired, it is recommended to remove this baffle to reduce system pressure drop. Refer to Figures 15.2 and 15.3.

Duct Installation

1. The furnace is designed to accept straight ductwork. See Figure 4.3. Provide an airtight seal between the ductwork and the furnace. Seams with cracks in ductwork should be caulked and/or taped and be of permanent type. All duct connections MUST be airtight to prevent air leakage.
2. Provide removable access panels on both the upstream and downstream sides of the ductwork; see Figure 4.3. These openings should be large enough to view smoke or reflect light inside the casing to indicate leaks in the heat exchanger and to check for hot spots on heat exchangers due to poor air distribution or lack of sufficient air (CFM)

Figure 4.3 - Duct Connections

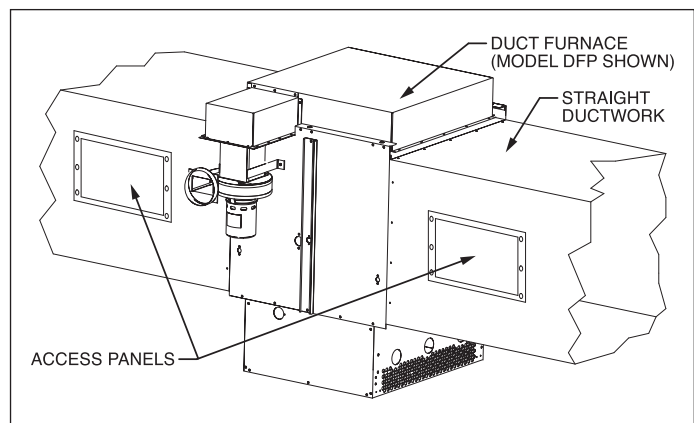

Airflow Distribution

IMPORTANT

To prevent premature heat exchanger failure, observe heat exchanger tubes by looking at the heat exchanger through field installed access openings in connecting ductwork. If the bottom of the tubes become red while blower and duct furnace are in operation, additional baffles must be inserted between blower and duct furnace to assure uniform air flow across the heat exchanger.

1. Provide uniform air distribution over the heat exchanger. Use turning vanes where required (see Figure 5.1) to obtain uniform air distribution. Avoid installing as in "G", "H" & "J" of Figure 5.1.
2. A bottom, horizontal discharge type blower should be installed at least 12" from the furnace (See "A", Figure 5.1).
3. A top, horizontal discharge type blower should be installed at least 24" from the furnace (See "B", Figure 5.1). Provide air baffle at top of duct to deflect air down to the bottom of heat exchanger.

INSTALLATION

Figure 5.1 - Typical Duct & Airflow Installation

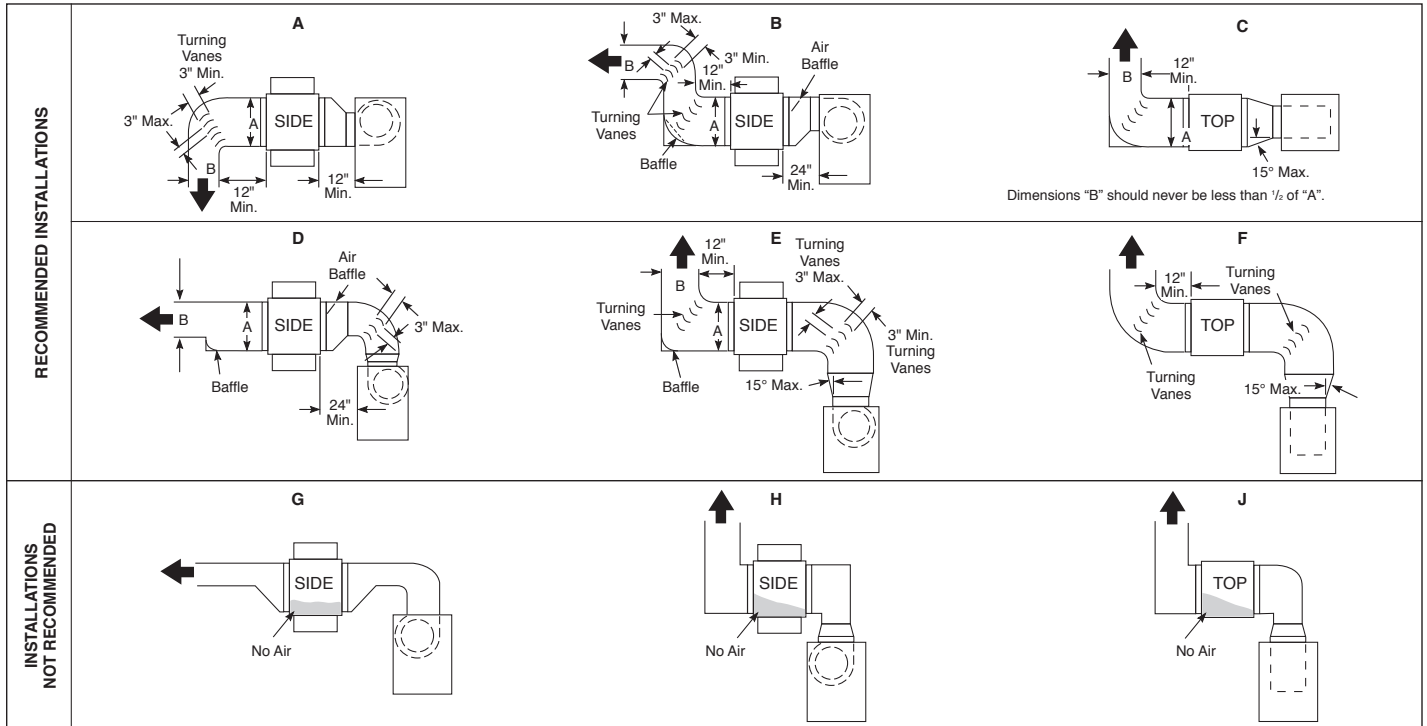

VENTING

⚠ WARNING

- Gas fired heating equipment must be vented - do not operate unvented.
- Model DFG has a built-in draft diverter - additional external diverters are not required or permitted.
 - Model DFP has a built-in power exhauster - additional external power exhausters are not required or permitted.
- If you are replacing an existing heater, it may be necessary to resize the venting systems. Improperly sized venting systems can result in vent gas leakage or the formation of condensate. Refer to the National Fuel Gas Code ANSI Z223.1 or CSA B149.1 latest edition. Failure to follow these instructions can result in injury or death.
- For Model DFG, gas-fired heating equipment which has been improperly vented, or which experiences a blocked vent condition may have flue gases accidentally spilled into the heated space. See page 22 for specific information about the blocked vent safety switch supplied on the unit.
- For Model DFP, under no circumstances should two sections of double wall vent pipe be joined together within one horizontal vent system due to the inability to verify complete seal of inner pipes.

General Venting Instructions

- Installation of venting must conform with local building codes, or in the absence of local codes, with the National Fuel Gas Code, ANSI Z223.1 (NFPA 54) - Latest Edition. In Canada, installation must be in accordance with CAN/CGA-B149.1 for natural gas units and CAN/CGA-B149.2 for propane units.
- To determine the Venting Category of the unit being installed, refer to Table 5.1.

Table 5.1 - Venting Category Determination

Model	Venting Category	Vent Configuration
DFG	I ①	Vertically vented units only.
DFP	I ①	Vertically vented units only.
	III ②	Horizontally vented units only.

- ① Vent is negative pressure, non-condensing. Follow standard venting requirements.
 ② Vent is positive pressure, non-condensing. Vent must be gastight.

- For units vented as Category I, refer to Table 5.2 for vent sizing. Vent sizing for units vented as Category III are covered in a later section on page 7. Do not use a vent pipe smaller than the size of the outlet or vent transition of the appliance. The pipe should be suitable corrosion resistant material. Follow the National Fuel Gas Code for minimum thickness and composition of vent material. The minimum thickness for connectors varies depending on the pipe diameter.

Table 5.2 - Category I Minimum Vent Pipe Diameter

Model Size	Minimum Vent Pipe Diameter	
	DFG	DFP
75	5"	4"
100-125	6"	4"
150-175	7"	5" ①
200-225	7"	6"
250	8"	6"
300-400	10"	6"

① Requires a 4" to 5" adapter for the larger vent pipe diameter.

VENTING

4. For Category I vent systems limit length of horizontal runs to 75% of vertical height. Install with a minimum upward slope from unit of 1/4 inch per foot and suspend securely from overhead structure at points no greater than 3 feet apart. For best venting, put vertical vent as close to the unit as possible. For Model DFP units, a minimum of 12" straight pipe is recommended from the power exhaustor outlet before turns in the vent system. Fasten individual lengths of vent together with at least three corrosion-resistant sheet-metal screws.
5. It is recommended that vent pipes be fitted with a tee with a drip leg and a clean out cap to prevent any moisture in the vent pipe from entering the unit. The drip leg should be inspected and cleaned out periodically during the heating season.
6. The National Fuel Gas Code requires a minimum clearance of 6 inches from combustible materials for single wall vent pipe. The minimum distance from combustible materials is based on the combustible material surface not exceeding 160°F. Clearance from the vent pipe (or the top of the unit) may be required to be greater than 6 inches if heat damage other than fire (such as material distortion or discoloration) could result.
7. Avoid venting through unheated space. When venting does pass through an unheated space, insulate runs greater than 5 feet to minimize condensation. Inspect for leakage prior to insulating and use insulation that is noncombustible with a rating of not less than 350°F. Install a tee fitting at the low point of the vent system and provide a drip leg with a clean out cap as shown in Figure 6.1.
8. When the vent passes through a combustible wall or floor, a metal thimble 4 inches greater than the vent diameter is necessary. If there is 6 feet or more of vent pipe in the open space between the appliance and where the vent pipe passes through the wall or floor, the thimble need only be 2 inches greater than the diameter of the vent pipe. If a thimble is not used, all combustible material must be cut away to provide 6 inches of clearance. Any material used to close the opening must be noncombustible.
9. Do NOT use dampers or other devices in the vent pipes.
10. Precautions must be taken to prevent degradation of building materials by flue products.
11. For category I vent systems the outlet of the vent should extend as shown in Figure 6.1 and Tables 6.1 and 6.2.
12. Use a listed vent terminal to reduce downdrafts and moisture in vent. For model DFG, a vent terminal that is very open will avoid spillage at unit's diverter relief opening and tripping of the blocked vent safety switch.
13. For instructions on common venting refer to the National Fuel Gas Code.
14. The vent must terminate no less than 5' above the vent connector for Category I vent systems.
15. A unit located within an unoccupied attic or concealed space shall not be vented with single wall vent pipe.
16. Single wall vent pipe must not pass through any attic, inside wall, concealed space, or floor.
17. Do NOT vent Model DFP units into a masonry chimney. Model DFG units can be vented into a masonry chimney if the following requirements are met:
 - a. Do not vent a Category I unit into a common vent with mechanical draft systems operating under positive pressure (Category III or IV units.)
 - b. When connecting a vent to an existing chimney, do not push the vent pipe beyond internal surface of chimney.
 - c. When venting into a common vent, the area of the common vent should be equal to or greater than the area of the largest vent plus 50 percent of the area of all additional vents.
 - d. When venting into a common vent, the individual vents should enter at different levels.

Figure 6.1 - Vertical Category I Vent System

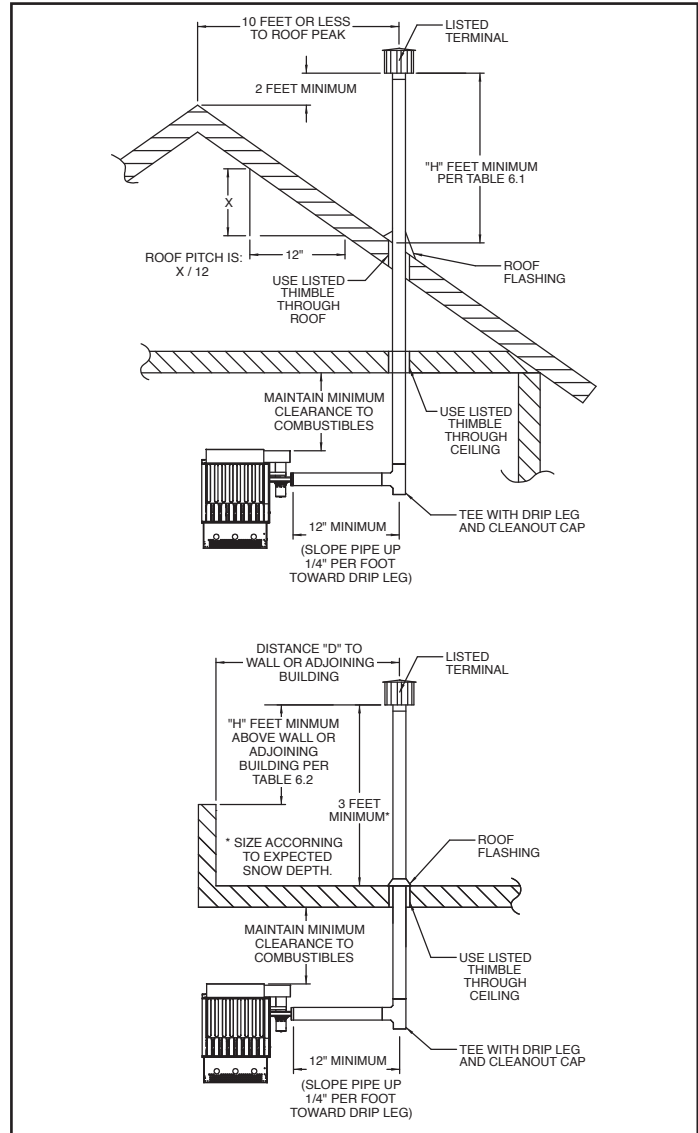

Table 6.1 - Minimum Height from Roof to Lowest Discharge Opening

Roof Rise "X" (in)	Equivalent Roof Pitch	Minimum Height "H" (ft) ①
0-10	Flat to 10/12	3.00
10-12	10/12 to 12/12	4.00
12-14	12/12 to 14/12	5.00
14-16	14/12 to 16/12	6.00
16-18	16/12 to 18/12	7.00
18-21	18/12 to 21/12	8.00

① Increase "H" as required to accommodate snow depth.

Table 6.2 - Minimum Height Above Adjacent Wall Less than 10 Feet Away

"D"	"H"
10 Feet or Less	2 Feet Minimum
Greater than 10 Feet	No Additional Height Required

VENTING

18. When condensation may be a problem, the venting system shall not terminate over public walkways or over an area where condensation or vapor could create a nuisance or hazard or could be detrimental to the operation of regulator relief openings or other equipment.
19. In cold ambient conditions, such as Canada, the following items are recommended for proper operation and equipment life:
 - The vent pipe must not pass through an unheated space or interior part of an open chimney unless the vent pipe is insulated.
 - Where the vent pipe may be exposed to extreme cold, or come into contact with snow or ice, the entire vent must be insulated or double wall (includes outdoors). It is preferred that the double wall vent is one continuous piece but a joint is allowed outside the building.
 - The heater system shall be checked at least once a year by a qualified service technician.

Additional Requirements for Horizontally Vented Category III Units (Model DFP units only)

1. Seal the joints with a metallic tape or silastic suitable for temperatures up to 350°F. (3M tapes 433 or 363 are acceptable.) Wrap tape two full turns around the vent pipe.
2. Refer to Table 7.1 for total minimum and maximum vent lengths making the vent system as straight as possible. The equivalent length of a 90° elbow is 5 feet for 4" diameter and 7 feet for 6" diameter.

Table 7.1 - Horizontal Category III Vent Sizing Requirements

Model Size	Vent Connector Diameter	Minimum Vent Pipe Diameter	Maximum Vent Length
75	4"	4"	48'
100-175	4"	4"	55'
200	6"	5" ①	70'
225	6"	6"	70'
250-300	6"	6"	63'
350-400	6"	6"	70'

① Unit can be vented with 5" diameter pipe if a 6" to 5" reducer is used. Otherwise, use 6" pipe.

3. The vent terminal must be Modine part number:
 - 5H072285-0001 (Item Code 27866) for 4" vent pipe
 - 5H072285-0004 (Item Code 27867) for 5" vent pipe
 - 5H072285-0002 (Item Code 27868) for 6" vent pipe
 A Gary Steel 1092 cap is an acceptable alternate.
4. The vent must extend a minimum of 12" beyond the exterior wall surface and must be supported as shown in Figure 7.1. Precautions must be taken to prevent degradation of building materials by flue products.
5. The vent system shall terminate at least 3 feet above any forced air inlet (except direct vent units) located within 10 feet, and at least 4 feet below, 4 feet horizontally from, or 1 foot above any door, window, or gravity air inlet into any building. The bottom of the vent terminal shall be located above the snow line or at least 1 foot above grade; whichever is greater. When located adjacent to public walkways the vent system shall terminate not less than 7 feet above grade.
6. The venting system must be exclusive to a single unit, and no other unit is allowed to be vented into it.
7. Horizontally vented units must use single wall vent pipe although one continuous section of double wall vent pipe may be used with the vent system. Under no circumstances should two sections of double wall vent pipe be joined together within one vent system due to the inability to verify complete seal of inner pipes.

Figure 7.1 - DFP Horizontal Venting

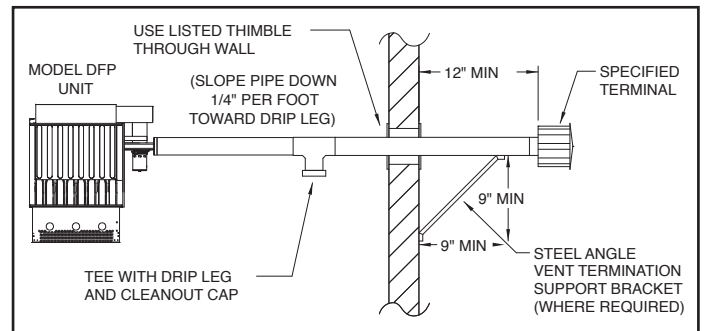

INSTALLATION

Gas Connections

⚠ WARNING

1. All field gas piping must be pressure/leak tested prior to operation. Never use an open flame. Use a soap solution or equivalent for testing.
2. Gas pressure to appliance controls must never exceed 14" W.C. (1/2 psi).
3. To reduce the opportunity for condensation, the minimum sea level input to the appliance, as indicated on the serial plate, must not be less than 5% below the rated input, or 5% below the minimum rated input of dual rated units.

⚠ CAUTION

Purging of air from gas lines should be performed as described in ANSI Z223.1 - latest edition "National Fuel Gas Code", or in Canada in CAN/CGA-B149 codes.

IMPORTANT

To prevent premature heat exchanger failure, the input to the appliance, as indicated on the serial plate, must not exceed the rated input by more than 5%.

1. Installation of piping must conform with local building codes, or in the absence of local codes, with the National Fuel Gas Code, ANSI Z223.1 (NFPA 54) - Latest Edition. In Canada, installation must be in accordance with CAN/CGA-B149.1 for natural gas units and CAN/CGA-B149.2 for propane units.
2. Piping to units should conform with local and national requirements for type and volume of gas handled, and pressure drop allowed in the line. Refer to Table 8.1 to determine the cubic feet per hour (cfh) for the type of gas and size of unit to be installed. Using this cfh value and the length of pipe necessary, determine the pipe diameter from Table 8.2. Where several units are served by the same main, the total capacity, cfh and length of main must be considered. Avoid pipe sizes smaller than 1/2". Table 8.2 allows for a 0.3" W.C. pressure drop in the supply pressure from the building main to the unit. The inlet pressure to the unit must be 6-7" W.C. for natural gas and 11-14" W.C. for propane gas. When sizing the inlet gas pipe diameter, make sure that the unit supply pressure can be met after the 0.3" W.C. has been subtracted. If the 0.3" W.C. pressure drop is too high, refer to the Gas Engineer's Handbook for other gas pipe capacities.
3. The gas piping to the unit can enter the unit from the side of the unit or from below. Install a ground joint union with brass seat and a manual shut-off valve external of the unit casing, and adjacent to the unit for emergency shut-off and easy servicing of controls, including a 1/8" NPT plugged tapping accessible for test gauge connection (See Figure 8.1).
4. Provide a sediment trap before each unit in the line where low spots cannot be avoided. (See Figure 8.1).
5. When Pressure/Leak testing, pressures above 14" W.C. (1/2 psi), close the field installed shut-off valve, disconnect the appliance and its combination gas control from the gas supply line, and plug the supply line before testing. When testing pressures 14" W.C. (1/2 psi) or below, close the manual shut-off valve on the appliance before testing.

Figure 8.1 - Recommended Sediment Trap/Manual Shut-off Valve Installation - Side or Bottom Gas Connection

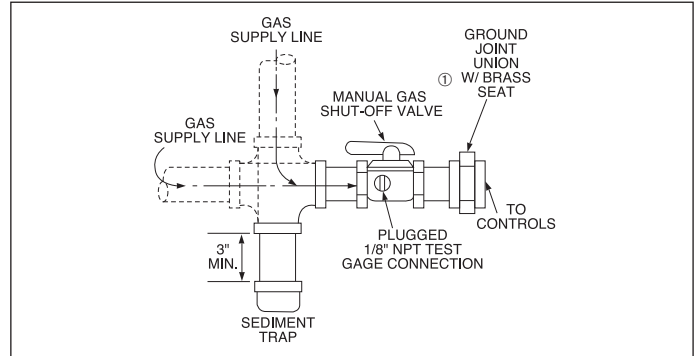

① Manual shut-off valve is in the "OFF" position when handle is perpendicular to pipe.

Table 8.1 - Burner Orifice Sizing and Gas Consumption

Model Size		Gas Type		Orifice Qty
		Natural ①	Propane ②	
75	Cfh	72.1	30.0	1
	Orifice Drill Size	20	39	
100	Cfh	96.1	40.0	2
	Orifice Drill Size	30	45	
125	Cfh	120.2	50.0	2
	Orifice Drill Size	25	42	
150	Cfh	144.2	60.0	3
	Orifice Drill Size	30	45	
175	Cfh	168.3	70.0	3
	Orifice Drill Size	27	43	
200	Cfh	192.3	80.0	3
	Orifice Drill Size	23	42	
225	Cfh	216.3	90.0	3
	Orifice Drill Size	20	39	
250	Cfh	240.4	100.0	4
	Orifice Drill Size	25	42	
300	Cfh	288.7	120.0	4
	Orifice Drill Size	20	39	
350	Cfh	336.5	140.0	6
	Orifice Drill Size	27	43	
400	Cfh	384.6	160.0	6
	Orifice Drill Size	23	42	

① Based on natural gas properties of 1040 Btu/Cu. Ft. and specific gravity of 0.60.

② Based on propane gas properties of 2500 Btu/Cu. Ft. and specific gravity of 1.53.

Table 8.2 - Gas Pipe Capacities - Natural Gas ① ②

Pipe Length (ft)	Natural Gas					
	1/2"	3/4"	1"	1-1/4"	1-1/2"	2"
10	132	278	520	1050	1600	3050
20	92	190	350	730	1100	2100
30	73	152	285	590	890	1650
40	63	130	245	500	760	1450
50	56	115	215	440	670	1270
60	50	105	195	400	610	1150
70	46	96	180	370	560	1050
80	43	90	170	350	530	930
100	38	79	150	305	460	870
125	34	72	130	275	410	780
150	31	64	120	250	380	710

① Capacities in Cubic Feet per Hour through Schedule 40 pipe with maximum 0.3" W.C. pressure drop with up to 14" W.C. gas pressure. Specific gravity is 0.60 for Natural gas and 1.50 for Propane gas.

② For Pipe Capacity with Propane Gas, divide Natural gas capacity by 1.6. Example: What is the Propane gas pipe capacity for 60 feet of 1-1/4" pipe? The Natural gas capacity is 400 CFH. Divide by 1.6 to get 250 CFH for Propane gas.

INSTALLATION

Considerations for Elevation

The standard ratings for Models DFG and DFP are certified for elevations up to 2000 feet above sea level. Operation at elevations above 2,000 feet requires ratings be reduced 4% for each 1000 feet above sea level per ANSI Z223.1. The exception is for units in Canada, CSA requires that ratings be reduced 10% for elevations between 2,001 and 4500 feet. The following instructions are for units that will be installed over 2,000 feet elevation. If this does not apply, you may skip ahead to the Electrical Connections section on page 10.

Manifold Pressure Adjustment

The unit manifold pressure is factory set for operation at elevations up to 2000 feet as follows:

- For **Natural Gas** units, 3.5" W.C. based on a gas heating value of 1,050 BTU/ft³.
- For **Propane Gas** units, 10.0" W.C. based on a gas heating value of 2,500 BTU/ft³.

For higher elevations, some utility companies may derate the BTU content (heating value) of the gas provided at altitude to a lower value to allow certain heating appliances to be used with no manifold pressure adjustments. For this reason it is necessary that the supplying utility be contacted for detailed information about the gas type and BTU content (heating value) before operating any heater. Table 9.1 shows the standard derated heating values of natural and propane gases at various elevations.

Table 9.1
Gas Heating Values at Altitude (Btu/ft³) ① ② ③ ④

Altitude (ft)	Natural Gas	Propane
0-2,000	1,050	2,500
2,001-3,000	929 ③	2212 ④
3,001-4,000	892 ③	2123 ④
4,001-4,500	874 ③	2080 ④
4,501-5,000	856	2,038
5,001-6,000	822	1,957
6,001-7,000	789	1,879
7,001-8,000	757	1,803
8,001-9,000	727	1,731
9,001-10,000	698	1,662

① Values shown are for 3.5" W.C. manifold pressure for Natural Gas and 10.0" W.C. for Propane Gas. If the local utility supplies gas with a different Btu/ft³ value, use Equation 9.1 to calculate the required manifold pressure.

② Gas heating values shown are derated 4% per 1,000' of elevation (10% between 2,000' and 4,500' elevation in Canada) in accordance with ANSI Z223.1 and CSA-B149, respectively.

③ 945 Btu/ft³ for Canada

④ 2,250 Btu/ft³ for Canada

⑤ When installed at altitudes above 2,000', a pressure switch may need to be changed. Refer to Tables 9.2 and 9.3 to determine if a switch change is required.

If the utility is supplying gas with heating values **SAME** as shown in Table 9.1, the manifold pressure should remain set to 3.5" W.C. for natural gas and 10.0" W.C. for propane gas and you may proceed to the section on this page titled "Selection of the Proper High Altitude Kit".

If the utility is supplying gas with heating values **DIFFERENT** than shown in Table 9.1, use Equation 9.1 to determine the appropriate manifold pressure for the elevation and gas heating value being supplied. Note what that value is, as it will be needed later for Start-Up. Proceed to the section on this page titled "Selection of the Proper High Altitude Kit".

Equation 9.1 - Manifold Pressure for Gas Heating Values Different Than Shown in Table 9.1

$$MP_{ELEV} = \left(\frac{BTU_{TBL}}{BTU_{ACT}} \right)^2 \times MP_{SL}$$

Where:

MP_{ELEV} = Manifold Pressure (" W.C.) at installed elevation

BTU_{TBL} = BTU/ft³ content of gas from Table 9.1

BTU_{ACT} = BTU/ft³ content of gas obtained from the utility company

MP_{SL} = Manifold Pressure (" W.C.), at Sea Level (use 3.5" W.C. for natural gas and 10.0" W.C. for propane)

NOTE: For units equipped with two-stage or modulating gas controls, only the high fire manifold pressure needs to be adjusted. No adjustments to the low fire manifold pressure are necessary on these units.

Selection of the Proper High Altitude Kit

All units installed at elevations greater than 2000 feet above sea level require a kit, in addition to potential manifold pressure adjustment outlined in the previous step. To determine the proper kit to use, refer to Table 9.2.

Table 9.3 shows the contents of the kit. For more information, refer to the latest revision of Modine Bulletin 75-530.

Table 9.2 - High Altitude Kit Selection Table ① ②

Model	Model Size	Item Code	Elevation Above Sea Level (ft)		
			2,001-5,500	5,501-6,500	6,501-7,500
DFG	All	Item Code	67248	67248	67248
DFP	75-350	Item Code	67248	67248	67248
	400	Item Code	67248	68409	68411

① Applies to both installations in the U.S. and Canada.

② Applies to both natural and propane gas.

Table 9.3 - High Altitude Kit Contents

Item Code	Kit Contents		
	High Altitude Conversion Label	Pressure Switch	Installation Instructions
67248	Yes	No	Yes
68409	Yes	Yes	Yes
68411	Yes	Yes	Yes

If a unit is to be installed at higher elevations AND converted from natural gas to propane gas operation, a propane conversion kit must be used in conjunction with the manifold pressure adjustment and high altitude kit listed above. For the Selection and Installation Instructions for propane conversion kits, please see the latest revision of Modine Bulletin 75-511.

INSTALLATION / START-UP PROCEDURE

Electrical Connections

WARNING

1. Disconnect power supply before making wiring connections to prevent electrical shock and equipment damage.
2. All appliances must be wired strictly in accordance with wiring diagram furnished with the appliance. Any wiring different from the wiring diagram could result in a hazard to persons and property.
3. Any original factory wiring that requires replacement must be replaced with wiring material having a temperature rating of at least 105°C.
4. Ensure that the supply voltage to the appliance, as indicated on the serial plate, is not 5% greater than rated voltage.

CAUTION

Ensure that the supply voltage to the appliance, as indicated on the serial plate, is not 5% less than rated voltage.

1. Installation of wiring must conform with local building codes, or in the absence of local codes, with the National Electric Code ANSI/NFPA 70 - Latest Edition. Unit must be electrically grounded in conformance to this code. In Canada, wiring must comply with CSA C22.1, Part 1, Electrical Code.
2. All duct furnaces are provided with a wiring diagram located on the inside door of the electrical junction box. Refer to this wiring diagram for all wiring connections. For factory installed options and field installed accessory wiring, refer to Set A and Set B on the provided wiring diagram.
3. The power supply to the duct furnace should be protected with a fused disconnect switch.
4. Refer to Table 10.1 to determine the amp draw of the duct furnace. For model DFG, the duct furnace amp draw is the Control Step Down Transformer Amp Draw (includes ignition controllers, gas valves, control relays, and amplifiers). For model DFP, the Power Exhauster Amp Draw must be added to the Control Step Down Transformer Amp Draw. Size the disconnect switch to cover the amp draw of the unit.
5. Refer to the unit dimensional drawings on pages 16-17 for the electrical knockout locations.

Table 10.1 - Unit Amps

Digit 14	Control Step Down Transformer Amp Draw (Models DFG and DFP)					Power Exhauster Amp Draw (Model DFP Only)		
	0 ①	1	2	3	4	75-175	200-400	
A	115/60/1	0	0.35	0.65	1.3	2.17	1.4	2.4
B	208/60/1	0	0.19	0.36	0.72	1.2	0.7	1.4
C	230/60/1	0	0.17	0.33	0.65	1.09	0.6	1.3
D	208/60/3	0	0.19	0.36	0.72	1.2	0.7	1.4
E	230/60/3	0	0.17	0.33	0.65	1.09	0.6	1.3
F	460/60/3 ②	0	0.09	0.16	0.33	0.54	0.30 ③	0.65 ④
G	575/60/3 ②	0	0.07	0.13	0.26	0.43	0.24 ③	0.52 ④

① Unit controls amp draw is included in master unit amp draw.

② For Digits F (460V) and G (575V), amp draw shown is on primary (line) side of required step-down transformer.

③ Requires a 250 VA transformer.

④ Requires a 500 VA transformer.

START-UP PROCEDURE

IMPORTANT

Start-up and adjustment procedures should be performed by a qualified service agency.

1. Turn off power to the unit at the disconnect switch. Check that fuses or circuit breakers are in place and sized correctly. Turn all hand gas valves to the "OFF" position.
2. Check that the supply voltage matches the unit supply voltage listed on the serial plate. Verify that all wiring is secure and properly protected. Trace circuits to insure that the unit has been wired according to the wiring diagram.
3. Check to insure that the venting system is installed and free from obstructions.
4. Check to see that there are no obstructions to the intake and discharge of the duct furnace.
5. Perform a visual inspection of the unit to make sure no damage has occurred during installation.
6. Turn on power to the unit at the disconnect switch. Check to insure that the voltage between terminals 1 and 2 is 24V.
7. Check the thermostat, ignition control, gas valve, power exhauster motor (model DFP only), and supply fan blower motor for electrical operation. If these do not function, recheck the wiring diagram. Check to insure that none of the Gas Control Options & Accessories (see page 14) have tripped.
8. Recheck the gas supply pressure at the field installed manual-shut-off valve. The inlet pressure should be 6"-7" W.C. on natural gas and 11"-14" W.C. on propane gas. If inlet pressure is too high, install an additional pressure regulator upstream of the combination gas control.
9. Open the field installed manual gas shut-off valve.
10. Open the manual main gas valve on the combination gas control. Call for heat with the thermostat. On a call for heat, the power exhauster relay will energize the power exhauster motor (model DFP only). Once the power exhauster motor has reached full speed, the differential pressure switch will close. The ignition controller will attempt to light the pilot. If the pilot does not light, purge the pilot line. If air purging is required, disconnect the pilot line at outlet of pilot valve. In no case should the line be purged into heat exchanger. Check the pilot flame length (See Pilot Burner Adjustment).
11. Once the pilot has been established, check to make sure that the main gas valve opens. Check the manifold gas pressure (See Main Burner Adjustment) and flame length (See Air Shutter Adjustment) while the circulating air blower is operating.
12. Check to insure that gas controls sequence properly (See Control Operating Sequence). Verify if the unit has any additional control devices and set according to the instructions in the Gas Controls Options.
13. Check vent system to see that combustion products are being vented properly. Operate unit for several minutes and then pass a lighted match around the edge of the diverter relief opening. If the flame is drawn into the opening, the vent system is drawing properly. If not, refer to page 22.
14. Once proper operation of the duct furnace has been verified, remove any jumper wires that were required for testing.
15. Close the electrical compartment door.
16. If installed at altitudes above 2,000', affix label included with high altitude kit and fill in all fields with a permanent marker.

START-UP PROCEDURE

Pilot Burner Adjustment

The pilot burner is orificed to burn properly with an inlet pressure of 6-7" W.C. on natural gas and 11-14" W.C. on propane gas, but final adjustment must be made after installation. If the pilot flame is too long or large, it is possible that it may cause soot and/or impinge on the heat exchanger causing failure. If the pilot flame is shorter than shown, it may cause poor ignition and result in the controls not opening the combination gas control. A short flame can be caused by a dirty pilot orifice. Pilot flame condition should be observed periodically to assure trouble-free operation.

To Adjust the Pilot Flame

1. Create a call for heat from the thermostat.
2. Remove the cap from the pilot adjustment screw. For location, see the combination gas control literature supplied with unit.
3. Adjust the pilot length by turning the screw in or out to achieve a soft steady flame 3/4" to 1" long and encompassing 3/8"-1/2" of the tip of the thermocouple or flame sensing rod (See Figure 11.1).
4. Replace the cap from the pilot adjustment screw.

Figure 11.1 - Correct Pilot Flame

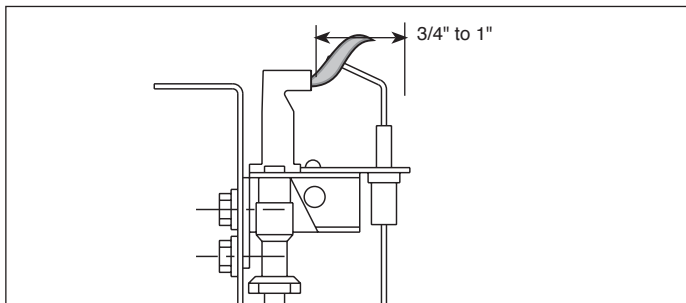

Main Burner Adjustment

The gas pressure regulator (integral to the combination gas control) is adjusted at the factory for average gas conditions. It is important that gas be supplied to the duct furnace in accordance with the input rating on the serial plate. Actual input should be checked and necessary adjustments made after the duct furnace is installed. Over-firing, a result of too high an input, reduces the life of the appliance and increases maintenance. Under no circumstances should the input exceed that shown on the serial plate.

Measuring the manifold pressure is done at the tee in the manifold for premium gas controls (Digit 13=0, 1, 2, or 3) or at the pressure tap on the gas valve for standard gas controls (Digit 13=4). (See Figure 11.2).

Figure 11.2 - Manifold Pressure Test Points

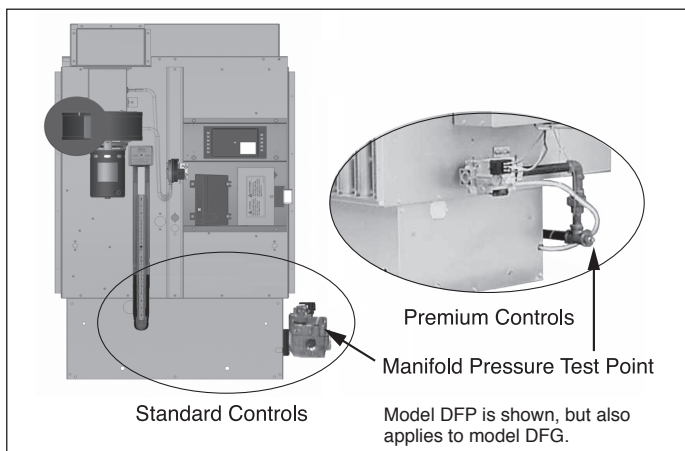

To Adjust the Manifold Pressure

1. Move the field installed manual shut-off valve to the "OFF" position.
2. Remove the 1/8" pipe plug in the pipe tee or gas valve and attach a water manometer of "U" tube type which is at least 12" high.
3. Move the field installed manual gas shut-off valve to the "ON" position.
4. Create a high fire call for heat from the thermostat.
5. Determine the correct high fire manifold pressure (3.5" W.C. for natural gas, 10" W.C. for propane gas). (Pressures at 0-2,000' elevation are 3.5" W.C. for natural gas, 10" W.C. for propane gas, for elevations above 2,000' refer to the instructions in "Gas Connections - High Altitude Accessory Kit" on page 9). Adjust the main gas pressure regulator spring to achieve the proper manifold pressure (for location, see the combination gas control literature supplied with unit).
6. If the unit has Electronic Modulation gas controls (determine from the Model Identification Digit 12), the low fire gas pressure needs to be adjusted. Using Figure 11.3 for item number locations, this is accomplished as follows:
 - a. Disconnect power.
 - b. Remove all wires from Maxitrol Amplifier terminal "3" or duct furnace terminal "43" (if available).
 - c. Turn on power at the disconnect switch.
 - d. Remove the maximum adjustment screw (4), spring (5), and plunger (8). A small magnet is useful for this purpose. CAUTION - The plunger is a precision part. Handle carefully to avoid marring or picking up grease and dirt. Do not lubricate.
 - e. Using minimum adjusting screw (9), adjust low fire manifold pressure to 0.56" W.C. for natural gas and 1.6" W.C. for propane gas.
 - f. Replace plunger and spring retainer, spring, and maximum adjusting screw in proper order.
 - g. Using maximum adjustment screw (4), adjust high fire manifold pressure to 3.5" W.C. for natural gas and 10" W.C. for propane gas.
 - h. Disconnect power.
 - i. Replace cover plate (2) and re-install all wires from Maxitrol amplifier terminal "3" or duct furnace terminal "43".
7. After adjustment, move the field installed manual shut-off valve to the "OFF" position and replace the 1/8" pipe plug.
8. After the plug is in place, move the field installed manual shut-off valve to the "ON" position and recheck pipe plugs for gas leaks with soap solution.

Figure 11.3 - Maxitrol Modulating Valve Adjustments

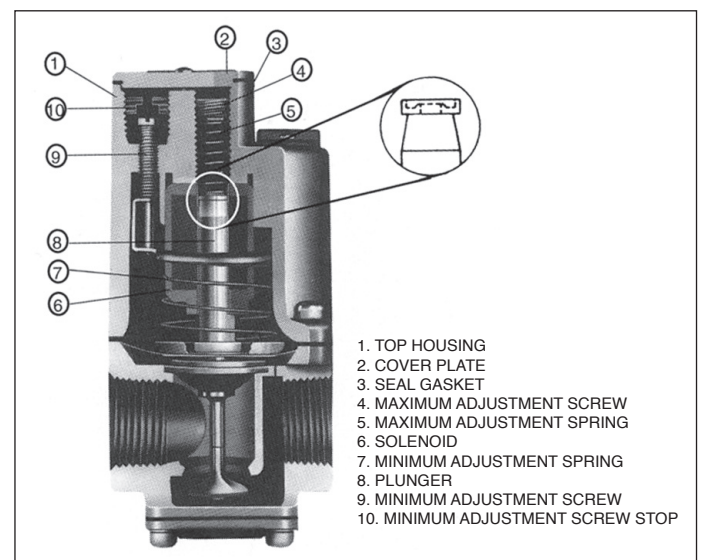

START-UP PROCEDURE

Air Shutter Adjustment

Proper operation provides a soft blue flame with a well-defined inner core. A lack of primary air will reveal soft yellow-tipped flames. Excess primary air produces short, well-defined flames with a tendency to lift off the burner ports. For both natural and propane gas, the air shutters can be adjusted to control the burner flame height. The air shutters can be accessed by reaching behind the gas valve in Figure 11.2. The larger models may require the removal of the manifold (see Manifold Assembly Removal).

Natural Gas Flame Control

Control of burner flames on duct furnaces utilizing natural gas is achieved by resetting the primary air shutters (See Figure 19.2) to either increase or decrease primary combustion air. Prior to flame adjustment, operate duct furnace for about fifteen minutes. The main burner flame can be viewed after loosening and pushing aside the gas designation disc on the side of the burner box.

To increase primary air, loosen the air shutter set screws and move the air shutters closer to the manifold until the yellow-tipped flames disappear. (See Figure 19.2 for air shutter and heat exchanger support locations.) To decrease primary air, move the air shutters away from the manifolds until flames no longer lift from burner ports, but being careful not to cause yellow tipping. Retighten set screws after adjustment.

Propane Gas Flame Control

An optimum flame will show a slight yellow tip. Prior to flame adjustment, operate furnace for at least fifteen minutes. Loosen air shutter set screws and move the air shutters away from the manifold to reduce the primary air until the yellow flame tips appear. Then increase the primary air until yellow tips diminish and a clean blue flame with a well defined inner cone appears.

IMPORTANT

To prevent premature heat exchanger failure, with all control systems, a blower starting mechanism must be provided so that the blower is running or energized within 45 seconds of the gas control operation.

Control Operating Sequence

Indoor gravity and power vented duct furnaces are supplied with intermittent pilot systems with continuous retry, which both the main burner and pilot burner are turned off 100% when the thermostat is satisfied. On a call for heat, the system will attempt to light the pilot for 70 seconds. If the pilot is not sensed for any reason, the ignition control will wait for approximately six minutes with the combination gas control closed and no spark. After six minutes, the cycle will begin again. After three cycles, some ignition controllers lockout for approximately one hour before the cycle begins again. This will continue indefinitely until the pilot flame is sensed or power is interrupted to the system.

Note: Gas Control Options (see page 14) could change the listed sequence of operation based on their function. The descriptions given are for the basic duct furnace.

Single Furnace Controls

Staged Control (Digit 12=1 or 2):

These units utilize a single- or two-stage combination gas valve, an ignition control, and a low voltage thermostat.

Electronic Modulating Control (Digit 12=4, 7, or 8):

These units utilize a single-stage combination gas valve, an electronic modulating gas valve, a modulating amplifier, an ignition control, and one of the following:

- Modulating room thermostat
- Modulating duct thermostat with remote temperature set point adjuster
- Building Management System (BMS) signal by others (an inverted signal where 0 VDC or 4 mA is high fire and 10 VDC or 20 mA is low fire).

The control operating sequence for all units is as follows:

1. The thermostat calls for heat. For BMS controlled units, the BMS closes a heat enable contact at the unit.
2. **Model DFP only** - The power exhauster relay is energized starting the power exhauster motor. Once the motor has reached full speed, the differential pressure switch closes. The power exhauster pre-purge time delay relay then closes after 20 to 40 seconds and energizes the gas control circuit.
3. The pilot valve opens and the spark igniter sparks in an attempt to light the pilot. (If the unit was not provided with a time delay relay, the blower starts).
4. Once the pilot is lit, the flame sensor proves the pilot and stops the spark igniter from sparking.
5. The main gas valve is opened and the main burner is controlled as follows:
 - a. **Single-Stage Units:** The main burner is lit to 100% full fire.
 - b. **Two-Stage Units:** The main burner is lit to 50% fire. If the temperature at the thermostat continues to fall, the thermostat will call for high stage heat and the main burner is lit to 100% full fire.
 - c. **Modulating Thermostat (Room or Duct):** The main gas valve is opened 100% and the burner firing rate is modulated between 40% and 100% full fire. A resistance

START-UP PROCEDURE

signal (8000 to 12000 ohms) in the thermostat is converted by the modulating amplifier to an inverted DC voltage (0VDC for high fire to 12 VDC for low fire). The output voltage is applied to the modulating gas valve to control the gas flow to the main burner. The modulating valve is modulated open or closed based on the voltage from the amplifier (less gas flow required = higher voltage, more gas flow required = lower voltage).

Note: When modulating duct sensing is utilized, a room override thermostat can be added. When the room override calls for heat, the burner modulates to full fire operation until the room override is satisfied. The unit then reverts back to duct sensing control. When equipped with both, either the duct sensor or the room override thermostat can call for heat.

- d. **BMS Signal:** The main gas valve is opened 100% and the burner firing rate is modulated between 40% and 100% full fire. A BMS 0-10VDC or 4-20mA signal (inverted, such that 0 VDC or 4 mA is high fire and 10 VDC or 20 mA is low fire) is converted by the signal conditioner/modulating amplifier into an inverted DC voltage (0VDC for high fire to 12 VDC for low fire). The output voltage is applied to the modulating gas valve to control the gas flow to the main burner. The signal conditioner can accept a 0-10 VDC signal when all the dip switches are in the "OFF" position and 4-20 mA signal when all the dip switches are in the "ON" position. The modulating valve is modulated open or closed based on the voltage from the amplifier (less gas flow required = higher voltage, more gas flow required = lower voltage), which correlates to the control signal from the BMS.
Note: For further information regarding the operation of any of the electronic modulating system options above, consult the literature provided with the unit.
6. If the unit was provided with a time delay relay, the blower starts after 30 to 45 seconds.
7. The unit continues to operate until the thermostat is satisfied, Once satisfied:
 - a. **Single-Stage Units:** Both the main and pilot valves close 100%.
 - b. **Two-Stage Units:** Once the high stage of the thermostat is satisfied, the main valve closes to 50% fire. The unit continues to operate until the low stage thermostat is satisfied, at which time both the main and pilot valves close 100%.
 - c. **Electronic Modulation Units:** The unit continues to operate in this manner until the thermostat is satisfied or the BMS heat enable contact opens. Power is then cut to both the main and pilot valves, closing them 100% and stopping gas flow to the main and pilot burners.
8. If the unit was not provided with a time delay relay, the blower stops immediately. If the unit was provided with a time delay relay, the blower stops after 30 to 45 seconds.

Multiple Furnace Controls

Staged Control (Digit 12=1 or 2):

For control of multiple staged units, each furnace would be individually controlled. Refer to the section for Single Furnace Controls, Staged Control (Digit 12=1 or 2).

Electronic Modulating Control (Digit 12=4):

Electronic modulation control of multiple furnaces with model nomenclature Digit 12=4 is not available. Refer to the section below for Electronic Modulating Control (Digit 12 = 5 and 6).

Electronic Modulating Control (Digit 12=7, or 8):

For control of multiple electronic modulation units for BMS control, each furnace would be individually controlled. Refer to the section for Single Furnace Controls, Electronic Modulation Control (Digit 12=7 or 8).

Electronic Modulating Control (Digit 12=5 and 6):

These units are the same as Electronic Modulating Gas Controls – Single Furnace (Digit 12=4) except the Master unit (Digit 12=5) features a modulating amplifier capable of driving multiple modulating gas valves for systems with a Master and up to three Slave units (Digit 12=6). Slave units do not have a modulating amplifier. The units would be controlled by one of the following:

- Modulating room thermostat
- Modulating duct thermostat with remote temperature set point adjuster

The sequence of operation for Electronic Modulating Gas Controls - Master/Slave is the same as Electronic Modulating Gas Controls - Single Furnace. The modulating amplifier sends an equal voltage signal to all of the modulating gas valves so that they modulate at the same percentage, between 40% and 100% full fire.

Variable Air Movement Applications

When the air mover supplied by others can provide variable air movement (i.e. variable frequency drive units), the allowable minimum CFM of the duct furnace can be 66% of the minimum listed CFM in Table 15.1 if the unit is applied as follows:

1. The unit is provided with 2-stage or electronic modulating gas controls (See Model Identification).
2. The unit is provided with a discharge air controller.
3. The system does not include a room thermostat.

The discharge air thermostat will prevent the unit from firing above the allowable 100°F rise when the unit is at or above the minimum CFM by monitoring the discharge air and going to low fire. A room thermostat, because it is located remote from the unit, could cause the unit to over-fire.

OPTIONS

Gas Control Options

The unit must be reviewed to determine if any of the listed gas control options were supplied.

① Time Delay Relay

The optional time delay relay allows the gas controls to operate for approximately 30 seconds before the blower starts. This allows the heat exchanger a warm up period so that the initial delivered air coming out of the ductwork is not cool. The time delay relay also keeps the motor running for approximately 30 seconds after the call for heat has been satisfied to remove the residual heat from the heat exchanger.

② Low Gas Pressure Switch

The switch monitors the gas pressure upstream of all the gas controls and shuts off the electric supply to the ignition controller and combination gas valve if low gas pressure is experienced. The switch has an automatic reset so that if the gas pressure is interrupted and then is returned, the switch will automatically allow the unit to operate when gas conditions are returned to the allowable range of the pressure switch. The pressure switch range is 2" to 14" W.C. and should be set to insure that the minimum inlet gas pressure is available (6" W.C. for natural gas, 11" W.C. for propane gas).

③ High Gas Pressure Switch

The switch monitors the gas pressure downstream of all the gas controls and shuts off the electric supply to the ignition controller and combination gas valve if high gas pressure is experienced right before the manifold. The switch has a manual reset so that if the gas pressure is too high, a service person must check the unit to make sure that none of the gas controls have been damaged by the high gas pressure and then reset the switch to allow the unit to operate when gas conditions are returned to the allowable range of the pressure switch. The pressure switch range is 2" to 16" W.C. and should be set to insure that the maximum manifold gas pressure is not exceeded (3.5" W.C. for natural gas, 10" W.C. for propane gas).

④ Supply Air Fire Stat

The fire stat is factory installed in the duct furnace electrical junction box with the sensor in the discharge air stream. In case of elevated temperatures in the supply air, the manual reset switch shuts down the entire unit. If the limit temperature is exceeded, a service person must inspect the unit for the cause of the high discharge temperature, take corrective action, and then reset the switch.

⑤ Timed Freeze Protection

The timed freeze protection system is factory installed in the duct furnace electrical junction box with the sensor (30°-75°F adjustable) factory installed in discharge air stream. On initial start-up, the timed delay in the system allows the unit to go through the normal ignition sequence. The timed delay is a manual reset switch and adjustable for 1-10 minutes. In the event that the unit fails to fire after this period, the discharge air sensor will sense the cold air and will shut down the entire unit.

⑥ Air Flow Proving Switch

The air flow proving switch is factory installed in the duct furnace electrical junction box. The air flow proving switch monitors the pressure differential between the duct furnace and the atmosphere. The purpose of the air flow proving switch is to cut power to the gas controls if a positive pressure is not measured by the switch.

This could be caused by a lack of air movement through the heat exchanger.

NOTE: The air flow proving switch will prevent any heat exchanger warm-up (the unit should not be equipped with a time delay relay) because the gas controls can not be energized until air flow is proven.

Setting the Air Flow Proving Switch

The range of the air flow proving switch is adjustable between 0.17" to 5.0" W.C.

1. Set the thermostat so that there is a call for heat. This should start the blower and fire the burner.
2. Turn the set screw of the pressure switch clockwise until it stops. This will set the pressure at 5.0" W.C.
3. Turn the screw counter-clockwise until the gas controls light and then one additional full turn (This is approximately 0.25" W.C.). This will allow for dirty filters or any other slight static pressure increases in the system.

⑦ Manual Reset High Limit

The manual reset high limit switch is factory installed in place of the standard automatic reset high limit switch located in the duct furnace electrical junction box. In case of a failure of the blower motor, blockage of the inlet air, etc., the manual reset switch prevents the unit from cycling on the high limit. If the limit temperature is exceeded, a service person must inspect the unit for the cause of the high discharge temperature, take corrective action, and then reset the switch.

Figure 14.1 - Location of Gas Control Options

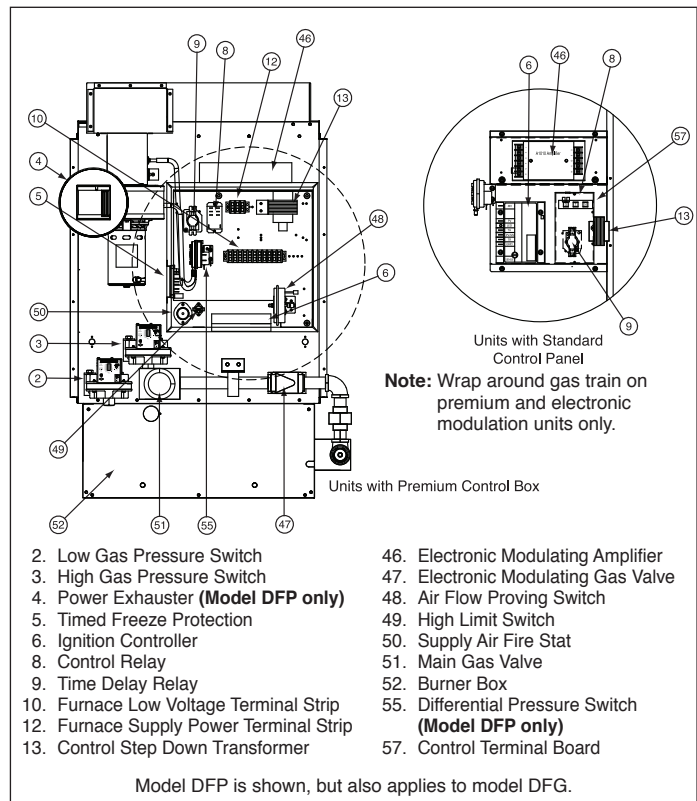

PERFORMANCE

Table 15.1 - Air Temperature Rise ① ②

Model Size	Input (Btu/Hr)	Output (Btu/Hr)	Air Temperature Rise Through Unit (°F)											
			20 ④	40 ④	50 ④	60	65	70	75	80	85	90	95	100
75	75,000	60,000	2,778	1,389	1,111	926	855	794	741	694	654	617	585	556
100	100,000	80,000	3,704	1,852	1,481	1,235	1,140	1,058	988	926	871	823	780	741
125	125,000	100,000	4,630	2,315	1,852	1,543	1,425	1,323	1,235	1,157	1,089	1,029	975	926
150	150,000	120,000	5,556	2,778	2,222	1,852	1,709	1,587	1,481	1,389	1,307	1,235	1,170	1,111
175	175,000	140,000	6,481	3,241	2,593	2,160	1,994	1,852	1,728	1,620	1,525	1,440	1,365	1,296
200	200,000	160,000	7,407	3,704	2,963	2,469	2,279	2,116	1,975	1,852	1,743	1,646	1,559	1,481
225	225,000	180,000	8,333	4,167	3,333	2,778	2,564	2,381	2,222	2,083	1,961	1,852	1,754	1,667
250	250,000	200,000	9,259	4,630	3,704	3,086	2,849	2,646	2,469	2,315	2,179	2,058	1,949	1,852
300	300,000	240,000	11,111	5,556	4,444	3,704	3,419	3,175	2,963	2,778	2,614	2,469	2,339	2,222
350	350,000	280,000	11,111	6,481	5,185	4,321	3,989	3,704	3,457	3,241	3,050	2,881	2,729	2,593
400	400,000	320,000	11,111	7,407	5,926	4,938	4,558	4,233	3,951	3,704	3,486	3,292	3,119	2,963

- ① Ratings are shown for elevations up to 2000 feet. For higher elevations, refer to section "Considerations for Elevation" on page 9.
- ② Minimum Air Temperature Rise is 20°F (23°F and a 27°F for the 350 and 400 model sizes respectively due to maximum airflow limits) and Maximum Air Temperature Rise is 100°F. The Maximum Discharge Air Temperature is 150°F.
- ③ For Variable Air Movement Applications, see page 13.
- ④ Models DFG and DFP are supplied with a factory installed air baffle. For applications where an air temperature rise less than 60°F is desired, it is recommended to remove this baffle to reduce system pressure drop. Refer to page 4.
- ⑤ The maximum CFM for the 350 and 400 sizes is 11,111CFM based on the maximum unit pressure drop.

Figure 15.1 - Recommended Unit Configurations ⑥

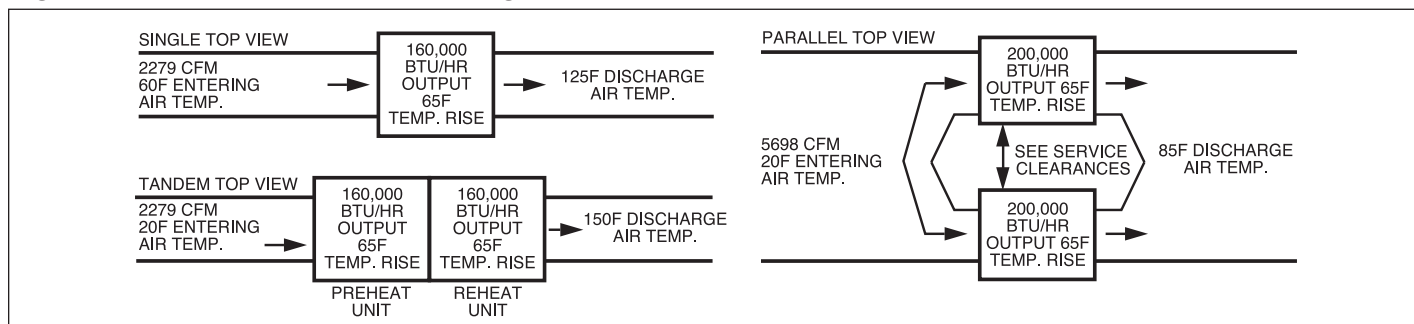

⑥ All duct furnaces are designed for a maximum allowable static pressure of 3.0" W.C. on the heat exchanger.

Figure 15.2 - Model DFG/DFP Pressure Drop vs CFM (Without Baffle)

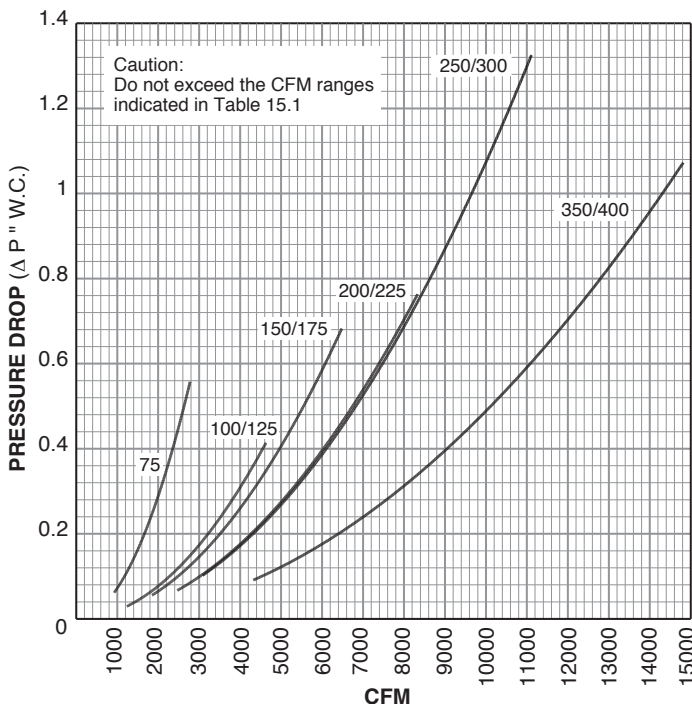
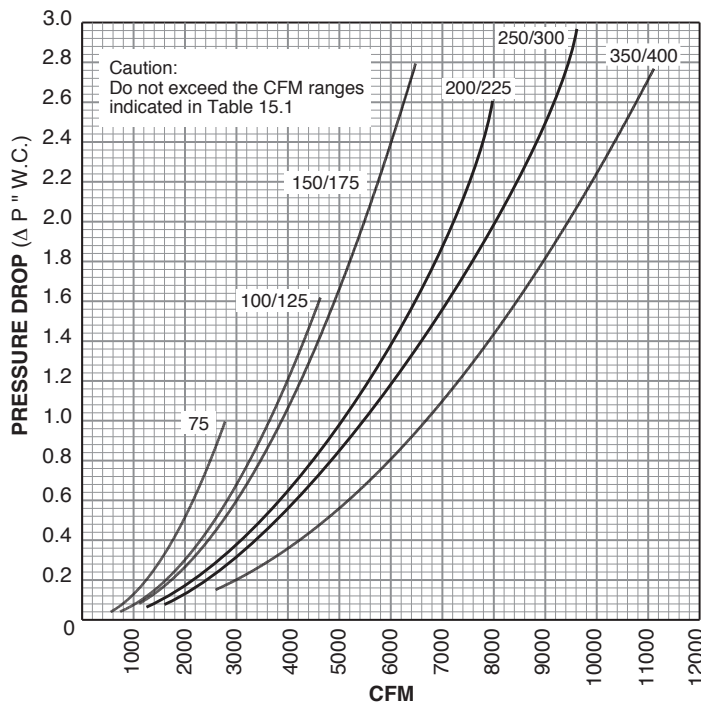

Figure 15.3 - Model DFG/DFP Pressure Drop vs CFM (With Baffle)



DIMENSIONAL DATA

Figure 16.1 - Indoor Gravity Vented Duct Furnace Dimensions

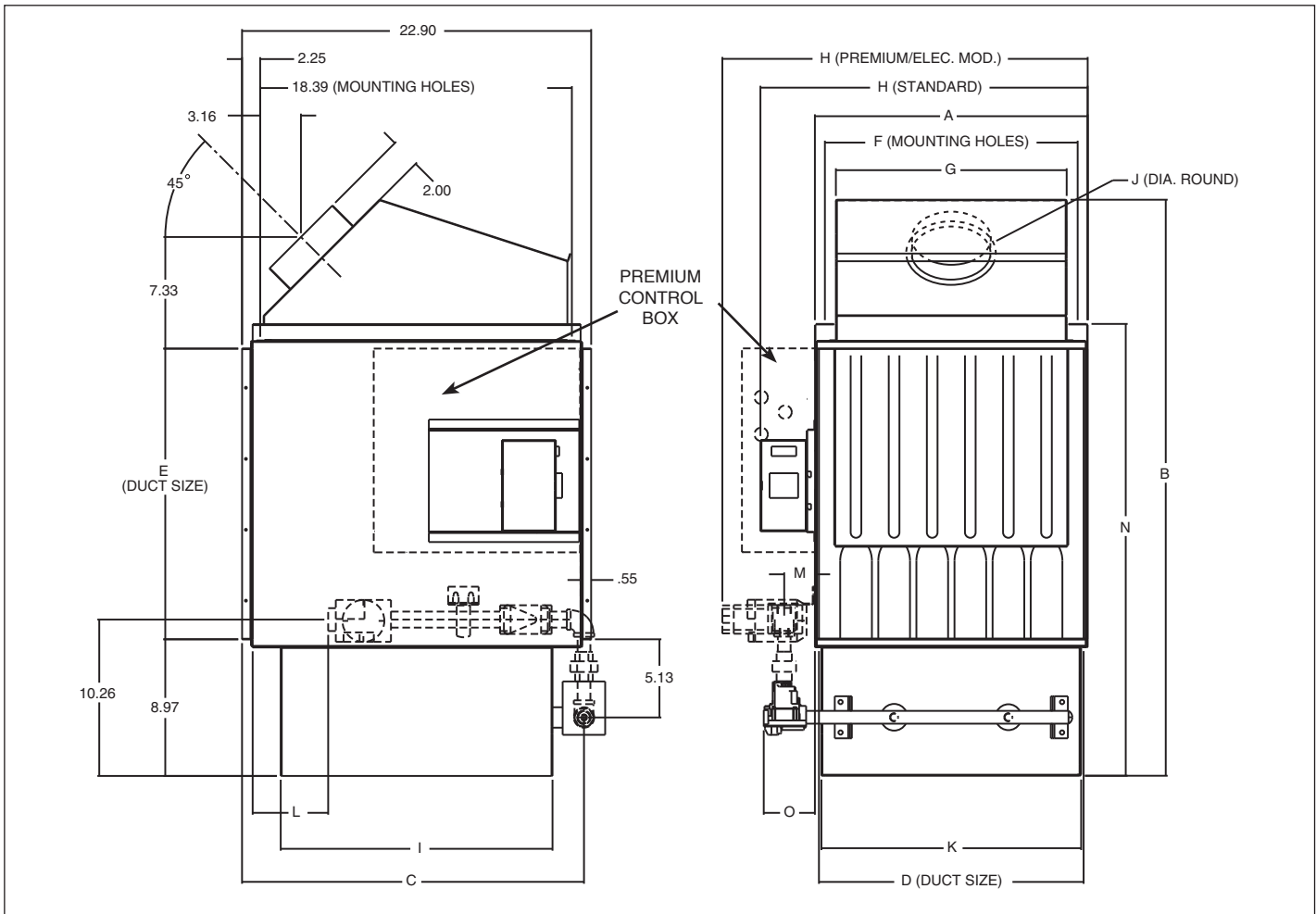

Table 16.1 - Indoor Gravity Vented Duct Furnace Dimensions

(All Dimensions in inches)

Dimensions	Model Size						
	75	100/125	150/175	200/225	250/300	350/400	
A	15.41	17.90	22.16	24.29	27.33	38.83	
B	37.80	37.80	37.80	41.80	41.80	41.80	
C	22.43	22.43	22.43	24.09	24.09	24.09	
D	15.21	17.70	21.96	24.09	27.13	38.63	
E	19.07	19.07	19.07	23.07	23.07	23.07	
F	14.09	16.59	20.85	22.98	26.01	37.51	
G	12.65	15.14	19.41	21.60	24.60	36.14	
H (standard)	18.98	21.47	25.73	28.06	31.40	42.40	
H (premium)	21.48	23.97	28.24	30.30	33.31	44.84	
I	17.83	17.83	17.83	20.68	20.68	20.68	
J	5	6	7	7	8/10	10	
K	14.55	17.04	21.31	23.26	26.44	37.80	
L (min. approx.)	5.0	5.0	5.0	6.6/6.1	6.1	6.1/5.8	
M	2.01	2.01	2.01	1.94	1.94	1.94	
N	29.65	29.65	29.65	33.65	33.65	33.65	
O (max. approx.)	5.6	5.6	5.6	6.8/6.2	6.2	8.3/8.6	
Gas Connection Pipe Size (max. std.)	1/2	1/2	1/2	1/2 / 3/4	3/4	3/4	
Gas Connection Pipe Size (max. prem.)	3/4	3/4	3/4	3/4	3/4	3/4	
Approx. Weight	Unit Shipping	89#	113#	140#	175#	213#	284#
	Unit Net	73#	95#	121#	155#	181#	251#

DIMENSIONAL DATA

Figure 17.1 - Indoor Power Vented Duct Furnace Dimensions

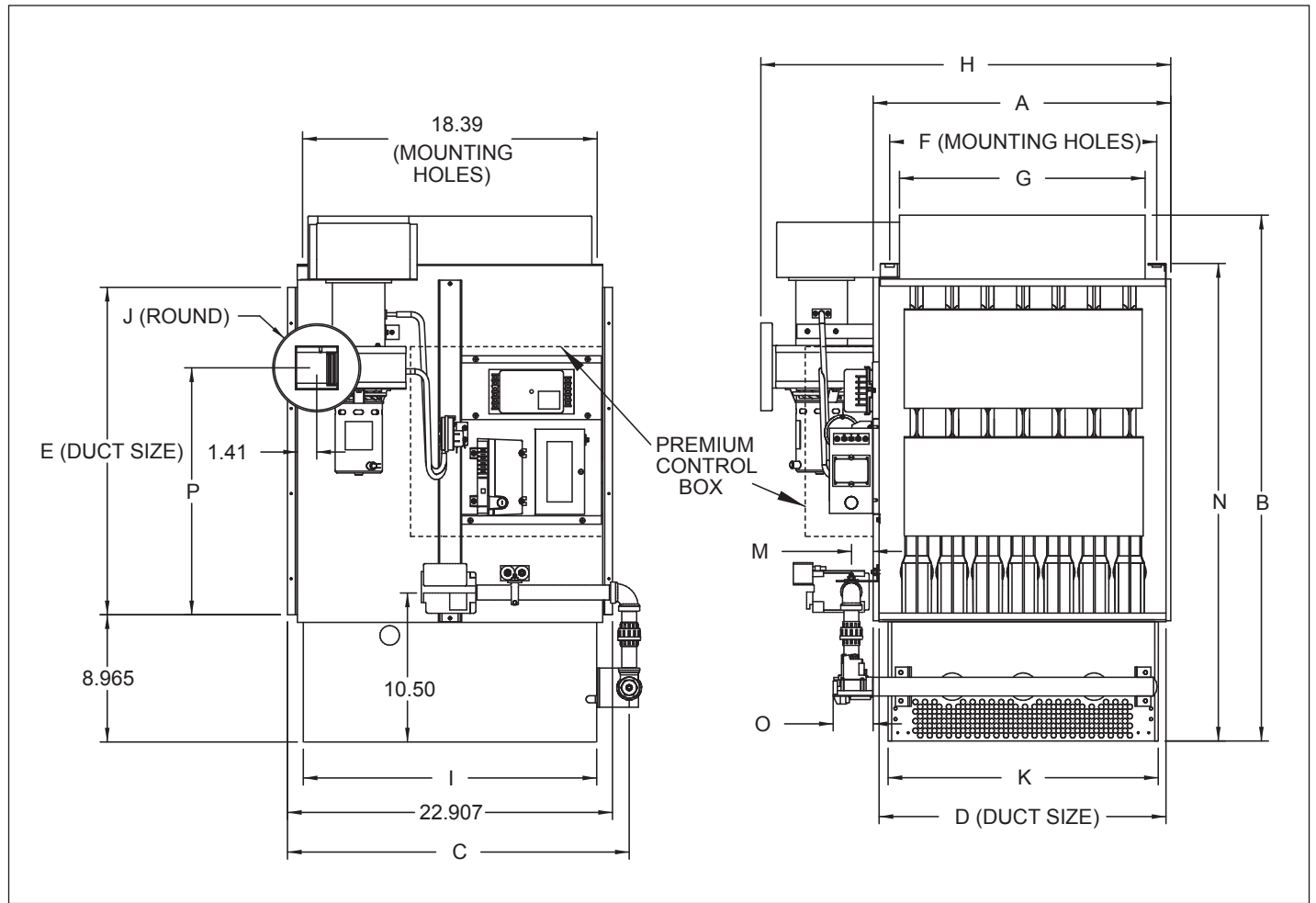

Table 17.1 - Indoor Power Vented Duct Furnace Dimensions

Dimensions		Model Size					
		75	100/125	150/175	200/225	250/300	350/400
A		15.41	17.90	22.16	24.29	27.33	38.83
B		33.05	33.05	33.05	37.05	37.05	37.05
C (standard)		22.43	22.43	22.43	24.09	24.09	24.09
D		15.21	17.70	21.96	24.09	27.13	38.63
E		19.07	19.07	19.07	23.07	23.07	23.07
F		14.09	16.59	20.85	22.98	26.01	37.51
G		12.65	15.14	19.41	21.60	24.60	36.14
H		23.75	26.26	30.51	32.78	35.79	47.32
I		17.83	17.83	17.83	20.68	20.68	20.68
J		4	4	4	6	6	6
K		14.55	17.04	21.31	23.26	26.44	37.80
M		2.01	2.01	2.01	1.94	1.94	1.94
N		29.65	29.65	29.65	33.65	33.65	33.65
O (max. approx.) (standard)		5.6	5.6	5.6	6.8/6.2	6.2	8.3/8.6
P		14.03	14.03	14.03	17.40	17.40	17.40
Gas Connection Pipe Size (max. std.)		1/2	1/2	1/2	1/2 / 3/4	3/4	3/4
Gas Connection Pipe Size (max. prem.)		3/4	3/4	3/4	3/4	3/4	3/4
Approx. Weight	Unit Shipping	101#	125#	152#	187#	225#	296#
	Unit Net	85#	107#	133#	167#	193#	263#

MAINTENANCE

WARNING

1. Installing, starting up and servicing heating, ventilation and air conditioning equipment poses significant hazards and requires specialized knowledge of Modine products and training in performing those services. Failure to have any service properly performed by, or making any modification to Modine equipment without the use of, qualified service personnel could result in serious injury to person and property, including death. Therefore, only qualified service personnel should work on any Modine products.
2. When servicing or repairing this equipment, use only factory-approved service replacement parts. A complete replacement parts list may be obtained by contacting Modine Manufacturing Company. Refer to the rating plate on the appliance for complete appliance model number, serial number, and company address. Any substitution of parts or controls not approved by the factory will be at the owner's risk.

CAUTION

Do not attempt to reuse any mechanical or electrical controllers which have been wet. Replace defective controller.

IMPORTANT

To check most of the Possible Remedies in the troubleshooting guide listed in Table 20.1, refer to the applicable sections of the manual.

All heating equipment should be serviced before each heating season to assure proper operations. The following items may be required to have more frequent service schedule based on the environment in which the unit is installed, and the frequency of the equipment operation.

Before any service, **BE SURE TO TURN OFF GAS AT THE MANUAL SHUT-OFF VALVE AHEAD OF THE COMBINATION GAS CONTROL AND TURN OFF ALL ELECTRIC POWER TO THE HEATER AND AIR MOVING SYSTEM.**

Blower Assembly

The blower assembly includes the bearings, drive sheaves and belts.

Blower bearings should be checked and lubricated based on the blower manufacturer's recommendations. Bearings should also be checked for any unusual wear and replaced if needed.

Drive sheaves should be checked at the same time the bearings are inspected. Check to make sure the sheaves are in alignment and are securely fastened to the blower and motor shafts.

Belt tension should be rechecked shortly after the unit has been installed to check for belt stretching. After the initial start-up, monthly checks are recommended.

Filters

If the unit is supplied with a dirty filter switch and light, clean or replace the filters any time the dirty filter light comes on.

Units which do not have a dirty filter warning light should have the filters checked monthly. Clean or replace if necessary. In dirty atmospheres, filter maintenance may be required more often.

Duct Furnace

When providing annual maintenance for the duct furnace, keep the unit free from dust, dirt, grease and foreign matter. Pay particular attention to:

1. The exhaust vent piping and vent terminal.
2. The burner ports and pilot burner orifices (avoid the use of hard, sharp instruments capable of damaging surfaces for cleaning these ports). To check the burner port and pilot burner orifice, see Burner and Pilot Assembly Removal.
3. The air shutters and main burner orifices (avoid the use of hard, sharp instruments capable of damaging surfaces for cleaning these orifices). To check the air shutters and main burner orifices, see for Manifold Assembly Removal.

The heat exchanger should be checked annually for cracks and discoloration of the tubes. If a crack is detected, the heat exchanger should be replaced before the unit is put back into service. If the tubes are dark gray, airflow across the heat exchanger should be checked to insure that a blockage has not occurred or the blower is operating properly.

Power Exhauster Motor (Model DFP only)

The power exhaust motor bearings have been lubricated for long life and do not require additional lubrication. In dirty atmosphere, it may be desirable to clean the motors and blower housing and blow out the cooling air passages of the motor with compressed air.

Electrical Wiring

The electrical wiring should be checked annually for loose connections or deteriorated insulation.

Gas Piping & Controls

The gas valves and piping should be checked annually for general cleanliness and tightness.

The gas controls should be checked to insure that the unit is operating properly.

Manifold Assembly Removal

To remove the manifold (refer to Figure 19.1)

1. Shut off gas and electric supply.
2. Disconnect gas manifold at ground union joint.
3. Remove the two screws holding the manifold to the heat exchanger support.
4. Slide the manifold through the manifold bracket.
5. Clean the orifices and adjust the air shutters as necessary.
6. Follow steps 3-6 in reverse order to install the manifold assembly.
7. Turn on the electric and gas supply.
8. Check the ground joint union for leaks with a soap solution. Tighten if necessary.

MAINTENANCE

Figure 19.1 - Manifold Assembly Removal

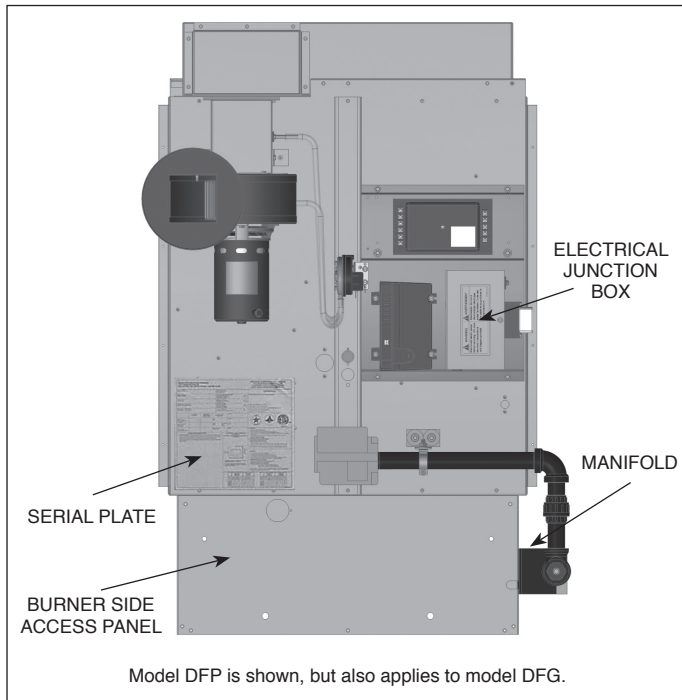
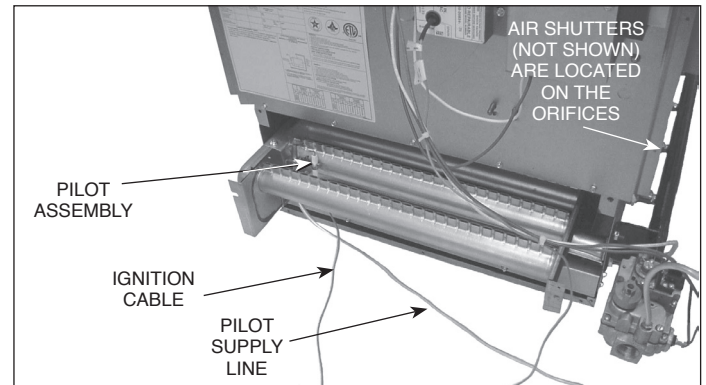

Figure 19.2 - Burner and Pilot Assembly Removal



Burner and Pilot Assembly Removal

To remove the burner (refer to Figure 19.2)

1. Shut off gas and electric supply.
2. Disconnect the pilot supply line from the gas valve.
3. Disconnect the ignition cable from the ignition controller (located in the electrical junction box). Feed the cable through the bushing in the bottom of the electrical junction box.
4. Remove the screws holding the burner side access panel. Attached to the panel are the burner retaining pins that align the burner.
5. Slide the burner assembly out. The pilot is attached to the burner assembly.
6. Examine the burner and pilot assembly for cleanliness and/or obstructions as necessary (see Duct Furnace for cleaning instructions).
7. Replace the burner assembly in reverse order. In replacing the burner, be certain that the rear burner slots are located properly on the burner retaining pins. Do not force the burner side access panel, it will not fit if the burner is not properly aligned.
8. Reconnect the ignition cable and pilot gas supply line.
9. Turn on the electric and gas supply.

SERVICE & TROUBLESHOOTING

Table 20.1 - Troubleshooting

Trouble	Possible Cause	Possible Remedy
Power Exhauster Motor will not start (Model DFP only)	<ol style="list-style-type: none"> 1. Power supply is off. 2. No 24V power to thermostat. 3. Thermostat malfunction. 4. Defective power exhauster relay. 5. Defective power exhauster motor. 	<ol style="list-style-type: none"> 1. Turn on main power. 2. Check control transformer. 3. Check/replace thermostat. 4. Replace power exhauster relay. 5. Replace power exhauster motor.
Pilot does not light/stay lit	<ol style="list-style-type: none"> 1. Main gas is off. 2. Power supply is off. 3. Air in gas line. 4. Dirt in pilot orifice. 5. Gas pressure out of proper range. 6. Pilot valve does not open. <ol style="list-style-type: none"> a. Defective ignition controller. b. Defective gas valve. 7. No spark at ignitor. <ol style="list-style-type: none"> a. Loose wire connections. b. Pilot sensor is grounded. c. Defective ignition controller. 8. Safety device has cut power. 9. Excessive drafts. 10. Pilot orifice fitting leak. 	<ol style="list-style-type: none"> 1. Open manual gas valve. 2. Turn on main power. 3. Purge gas line. 4. Check for plugged pilot orifice and clean with compressed air if necessary. 5. Adjust to a maximum of 14" W.C. Minimum for Natural Gas - 6" W.C. Minimum for Propane Gas - 11" W.C. 6. Check wiring for 24 volts to valve. <ol style="list-style-type: none"> a. Replace ignition controller. b. Replace gas valve. 7. <ol style="list-style-type: none"> a. Check all ignition controller wiring. b. Replace sensor if cracked or worn. c. Replace ignition controller. 8. Check all safety devices (High limit, air flow proving switch, differential pressure switch, gas pressure switches, etc.) Determine and correct problem. Reset if necessary. 9. Find source and re-direct airflow away from unit. 10. Tighten pilot orifice. Flame impingement on pilot sensor may cause pilot sensor to become inoperative.
Main burners do not light (Pilot is lit)	<ol style="list-style-type: none"> 1. Defective valve. 2. Loose wiring. 3. Defective pilot sensor. 4. Defective ignition controller. 5. Improper thermostat wiring. 6. Blocked vent safety switch tripped. (Model DFG only) 	<ol style="list-style-type: none"> 1. Replace valve. 2. Check wiring to gas valve. 3. Replace pilot sensor. 4. Replace ignition controller. 5. Verify wiring compared to wiring diagram. 6. Refer to page 22.
Lifting Flames (See Figure 21.1)	<ol style="list-style-type: none"> 1. Too much primary air. 2. Main pressure set too high. 3. Orifice too large. 	<ol style="list-style-type: none"> 1. Reduce primary air. 2. Adjust to a maximum of 14" W.C. 3. Check orifice size with those listed on the serial plate.
Yellow Tipping (With propane gas, some yellow tipping is always present.)	<ol style="list-style-type: none"> 1. Insufficient primary air. 2. Dirty orifice. 3. Misaligned orifice. 	<ol style="list-style-type: none"> 1. Increase primary air. 2. Check orifices and clean with compressed air if necessary. 3. Check manifold, replace if necessary.
Flashback	<ol style="list-style-type: none"> 1. Too much primary air. 2. Main pressure set too high. 3. Orifice too large. 	<ol style="list-style-type: none"> 1. Reduce primary air. 2. Adjust to a maximum of 14" W.C. 3. Check orifice size with those listed on the serial plate.
Floating Flames (See Figure 21.2)	<ol style="list-style-type: none"> 1. Insufficient primary air. 2. Main pressure set too high. 3. Orifice too large. 4. Blocked vent. 	<ol style="list-style-type: none"> 1. Increase primary air. 2. Adjust to a maximum of 14" W.C. 3. Check orifice size with those listed on the serial plate. 4. Clean/correct venting system.
Flame Rollout (See Figure 21.3)	<ol style="list-style-type: none"> 1. Main pressure set too high. 2. Orifice too large. 3. Blocked vent. 	<ol style="list-style-type: none"> 1. Adjust to a maximum of 14" W.C. 2. Check orifice size with those listed on the serial plate. 3. Clean/correct venting system.

SERVICE & TROUBLESHOOTING

Trouble	Possible Cause	Possible Remedy
<p>Not Enough Heat</p>	<ol style="list-style-type: none"> 1. Unit cycling on high limit. <ol style="list-style-type: none"> a. Obstructions/leaks in duct system. b. Main pressure set too high. c. Blower motor not energized. d. Loose belt e. Blower speed too low. f. Blocked/damaged venting system. g. Air distribution baffle removed (high temperature rise units only). h. Defective high limit switch. <ol style="list-style-type: none"> 2. Main pressure set too low. <ol style="list-style-type: none"> 3. Too much outside air. <ol style="list-style-type: none"> 4. Thermostat malfunction. 5. Gas controls wired incorrectly. <ol style="list-style-type: none"> 6. Unit undersized. 	<ol style="list-style-type: none"> 1. <ol style="list-style-type: none"> a. Clean/correct duct system. b. Adjust to a maximum of 14" W.C. c. Check/correct to insure blower motor operates within 45 seconds of when - gas controls are energized. d. Adjust belt tension. e. Check/correct blower drive settings for proper rpm. f. Check/correct venting system. g. Replace air distribution baffle. h. Replace high limit switch. 2. Adjust main gas pressure. Minimum for Natural Gas — 6" W.C. Minimum for Propane Gas — 11" W.C. 3. Adjust outside air damper to decrease outside air percentage (if possible). 4. Check/replace thermostat. 5. Check unit wiring against the wiring diagram. 6. Check design conditions. If unit is undersized, an additional unit(s) or other heat source must be added.
<p>Too Much Heat</p>	<ol style="list-style-type: none"> 1. Thermostat malfunction. 2. Gas controls do not shut-off. <ol style="list-style-type: none"> a. Gas controls wired incorrectly. b. Short circuit. 3. Main gas pressure set too high. 4. Defective gas valve. 	<ol style="list-style-type: none"> 1. Check/replace thermostat. 2. <ol style="list-style-type: none"> a. Check unit wiring against the wiring diagram. b. Check for loose or worn wires. 3. Adjust to a maximum of 14" W.C. 4. Replace gas valve.

① Automatic Reset High Limit

The duct furnace comes standard with an automatic reset high limit switch that will shut-off the gas should the discharge air temperature become excessive. See Figure 14.1, indicator ⑦ for the location of either the standard automatic or optional manual reset high limit switch. The switch should operate only when something is seriously wrong with the unit operation. Anytime the switch operates, correct the difficulty immediately or serious damage may result. If the switch cuts off the gas supply during normal operation, refer to the "Not Enough Heat" section of Service & Troubleshooting.

Figure 21.1
Lifting Flame Condition

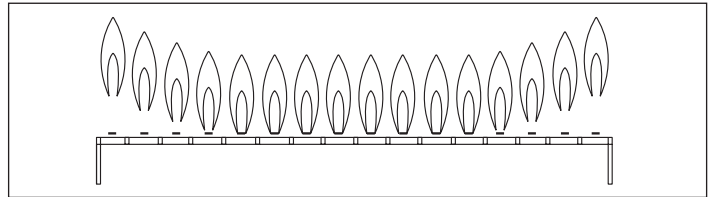

Figure 21.2
Floating Flame Condition

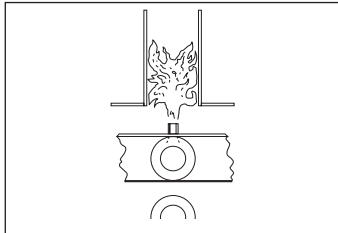
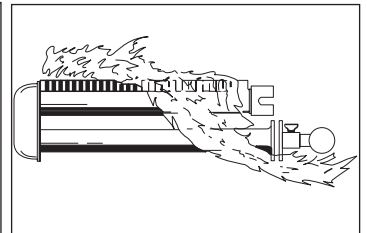

Figure 21.3
Flame Rollout Appearance



SERVICE & TROUBLESHOOTING

Blocked Vent Safety Switch

A manual reset blocked vent safety switch is supplied on all Model DFG units and is designed to prevent operation of the main burner in the event there is spillage of flue products into the space. This spillage may occur due to a restricted vent, inadequate vent draw, uninsulated vent pipe in cold ambient, long vent runs, excessive vent diameter, restrictive vent terminal, negative pressure within space, etc. After the cause of the spillage has been corrected, depressing the button of the blocked vent safety switch found on top of the unit may reset the switch. See Figure 22.2 for additional troubleshooting information.

Figure 22.1 - Blocked Vent Safety Switch Location

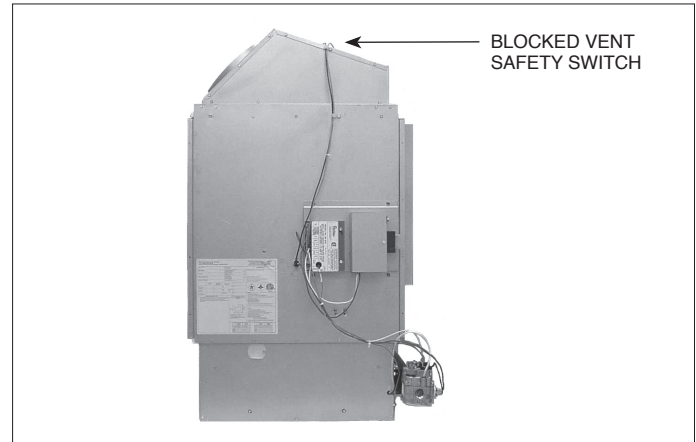
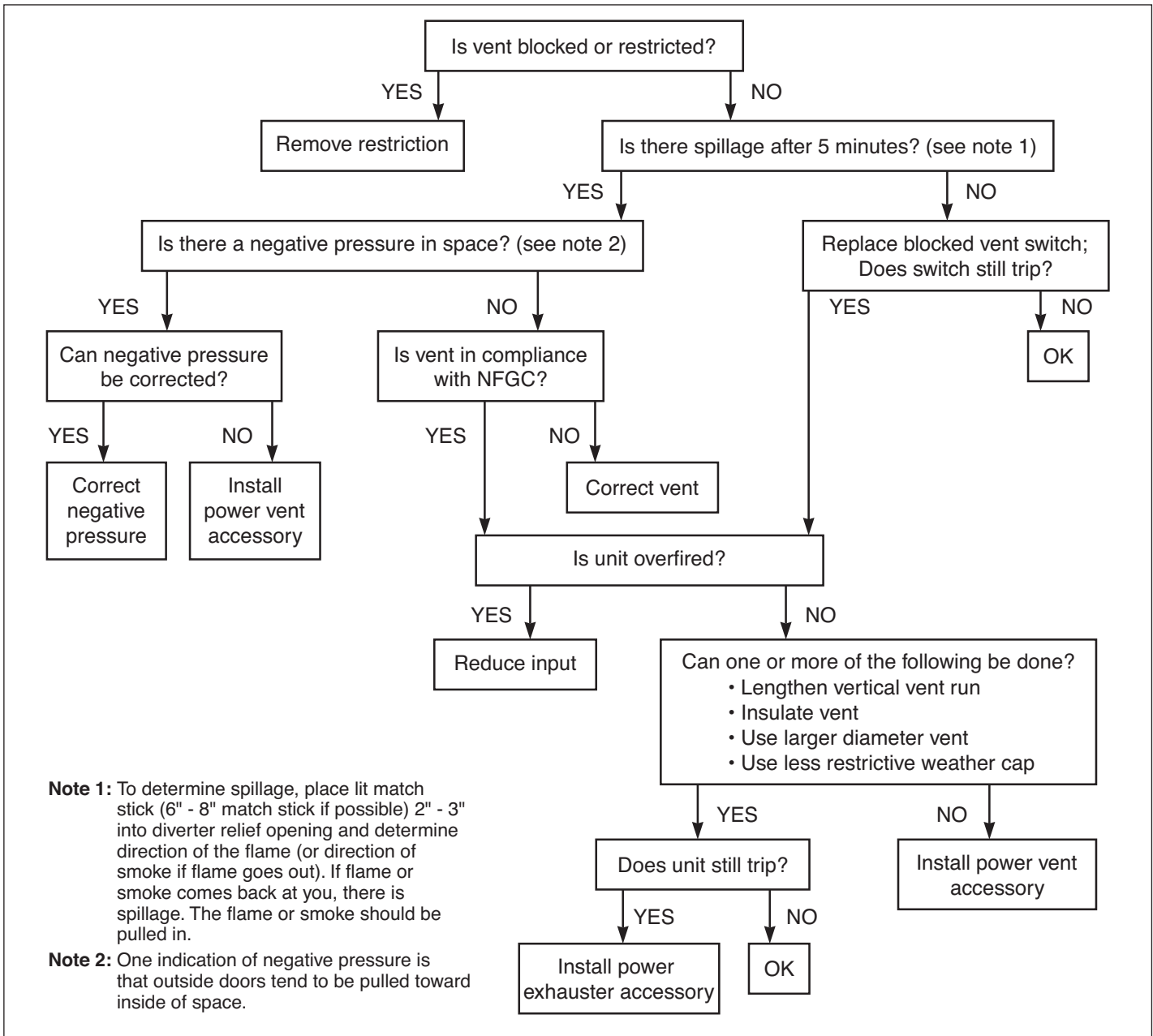

Figure 22.2 - Blocked Vent Safety Switch Troubleshooting Flow Chart (Model DFG only)



REPLACEMENT PARTS ORDERING

Ordering

When servicing, repairing or replacing parts on these units, locate the serial plate of the unit and always give the complete Model Number and Serial Number from the serial plate. The serial plate is located on the door of the electrical control box or

on the side of unit. The Modine Manufacturing Company part number for some common replacement parts are listed on the sample serial plate. For a complete description of the model number, see Model Identification.

Figure 23.1

Modine Manufacturing Company
1500 Dekoven Avenue, Racine, WI 53403-2552
Phone: 1-866-823-1631

Made in U.S.A.

GAS-FIRED DUCT FURNACE FOR INDUSTRIAL / COMMERCIAL USE
GENERATEUR D AIR CHAUD A GAINÉ POUR USAGE INDUSTRIEL/COMMERCIAL

MODEL NUMBER NUMERO DE MODELE DFP400AMRNN2 4A154321		(IN USA) FOR INSTALLATIONS ABOVE 2000 FEET, DERATE 4% FOR EACH 1000 FEET OF ELEVATION ABOVE SEA LEVEL (IN CANADA)		VOLTS 115	AMPS 2.35	PHASE 1	HERTZ 60	APPROVALS APPROVED FOR USE IN MASSACHUSETTS APPROVED FOR USE IN CA BY THE CEC ACCEPTED BY CITY OF NEW YORK
SERIAL NUMBER NUMERO DE SERIE S0917094908-0034		0 TO 2000 FT. 0 ET 610 M	2000 TO 4500 FT. 610 ET 1370 M	MINIMUM CLEARANCE TO COMBUSTIBLE MATERIAL DÉGAGEMENT MINIMUM POUR MATIÈRES COMBUSTIBLES				
MIN. INPUT DEBIT CALORIFIQUE 200000 BTU/HR	TYPE OF GAS TYPE DE GAZ Natural	INPUT DEBIT CALORIFIQUE 400000 BTU/HR 117120W	OUTPUT REDDNMENT 320000 BTU/HR 93696 W	TOP HAUT 2 IN 5.08 cm	BOTTOM BAS 2 IN 5.08 cm	ACCESS SIDE CÔTÉ D'ACCÈS 6 IN 15.24 cm	VENT CONNECTOR CONNECTEUR D'ABRATON 3 IN 7.62 cm	
MIN. INLET PRESS. FOR PURPOSES OF INPUT ADJ PRESSION D'ALIMENTATION EN GAZ MIN. ADMISE 6 IN W.C. 1.49 kPa	RECOMMENDED SERVICE CLEARANCES / DÉGAGEMENT DE SERVICE RECOMMENDE ACCESS CÔTÉ SIDE ACCÈDEZ 41 IN 104.14 cm	ORIFICE SIZE DIM. DE L'ÉLECTEUR 23	ORIFICE SIZE DIM. DE L'ÉLECTEUR 23	NON-ACCESS SIDE NON-COTÉ D'ACCÈS 2 IN 5.08 cm	AIR THROUGHPUT DEBIT D'AIR DESIGN COMPLIES WITH DUCT FURNACE STANDARD:			
TEMPERATURE RISE RANGE ELEVATION DE TEMPERATURE 20-100 °F	VENT CATEGORY ÉVÈNT CATÉGORIE III / I	MAXIMUM EXTERNAL STATIC PRESSURE PRESSION STATIQUE EXTERIEUR MAX 3 IN W.C. / PO. CD'B	VENT CONNECTOR SIZE CONNECTEUR DE VENTILATION 6 IN / PO.	MINIMUM 2963 CFM	MAXIMUM 11111 CFM	MIN VARIABLE SPEED 2222 CFM	CSA 2.6-2013 ANSI Z83.8-2013 MEA372-01-E	

INSTALL ON THE POSITIVE PRESSURE SIDE OF AIR CIRCULATING BLOWER.
INSTALLER DU CÔTÉ DE LA PRESSION POSITIVE DU VENTILATEUR.

GENERAL

FOR INDOOR INSTALLATIONS ONLY.
MINIMUM AMBIENT TEMPERATURE -40°F.

FOR INSTALLATION DOWNSTREAM OF REFRIGERATION SYSTEMS.

FOR UNITS WITH MANUAL RESET HIGH LIMIT SWITCH, RESET BUTTON IS LOCATED IN ELECTRICAL JUNCTION BOX.

(IN USA) FOR INSTALLATIONS ABOVE 2000 FEET, DERATE 4 PERCENT FOR EACH 1000 FEET OF ELEVATION ABOVE SEA LEVEL.

THIS APPLIANCE REQUIRES A SPECIAL VENTING SYSTEM. REFER TO INSTALLATION INSTRUCTIONS NO. 5-564 FOR PARTS LIST AND METHOD OF INSTALLATION.

GÉNÉRAL

SEULEMENT POUR INSTALLATION INTÉRIÈURE
LA TEMPERATURE MINIMUM DE L'AIR DEDORS EST -40°C.

INSTALLER DU CÔTÉ DE LA PRESSION POSITIVE DU VENTILATEUR.

POUR APPAREILS AVEC INTERRUPTEUR REMIS MANUEL HAUT-LIMITE, REMISE EST SITUÉE DANS LA BOÎTE JUNCTION ÉLECTRIQUE. POUR REMETTRE PRESSER LE BOUTON.

CET APPAREIL NÉCESSITE UN SYSTÈME D'ÉVACUATION SPÉCIAL. LA MÉTHODE D'INSTALLATION ET LA LISTE DES PIÈCES NÉCESSAIRES FIGURENT DANS LES INSTRUCTIONS

LIGHTING INSTRUCTIONS

1. OPEN ALL GAS VALVES. TURN ON POWER.
2. SET THERMOSTAT TO DESIRED SETTING.

REFER TO INSTALLATION AND SERVICE MANUAL FOR MORE INSTRUCTIONS

* FOR UNITS WITH TWO STAGE, MECHANICAL MODULATION, OR ELECTRONIC MODULATING GAS CONTROLS, A FACTORY DISCHARGE AIR CONTROLLER AND NO ROOM THERMOSTAT INCLUDED.

SHUT DOWN INSTRUCTIONS:

1. TURN OFF POWER & CLOSE ALL GAS VALVES.

INSTRUCTIONS D'ALLUMAGE

1. DUVRIER TOUTES LES ROBINETS A GAZ. DONNER LE COURANT.
2. REGLER LE THERMOSTAT SUR LA POSITION DESIRÉE.

REFERREZ AU MANUAL D'INSTALLATION ET DE SERVICE POUR PLUS D' INSTRUCTIONS

* POUR APPAREILS AVEC DEUX PHASES MODULATION MÉCANIQUE, OU APPAREILS DE CONTRÔLE DE GAZ ÉLECTRIQUES MODULÉS, UN AIR CONTRÔLEUR DÉCHARGE INSTALLÉ À LA MANUFACTURE, ET THERMOSTAT DE CHAMBRE N'EST PAS INCLUS.

INSTRUCTIONS DE FER METURE:

1. COUPER LE COURANT ET FERMER TOUTES LES ROBINETS A GAZ.

COMMON REPLACEMENT PARTS

FOR PARTS ORDERING, contact the parts wholesaler or the manufacturer representative serving your area. WHEN INQUIRING ABOUT PARTS, always provide model number, serial number, description and part number. When ordering parts, provide part number listed. FOR SERVICE, contact your local qualified installation and service contractor or appropriate	5H080687 5H080689 5H71675- 5H79441-3 5H73598-1 5H80563-4	Comb. Gas Valve Ignition Control TD1 Relay Pressure Switch Power Exhauster Wiring Diagram	5H71956-1 3H37454-1 3H37398-11 3H35628-6 5H71790-	Ctrl Transformer Pilot Replace Kit Heat Exch. Kit Burner Kit Optional TDR
---	---	--	---	---

MODEL IDENTIFICATION

Indoor Gravity and Power Vented Duct Furnace Model Nomenclature

1	2	3	4 5 6	7	8	9	10	11	12	13	14	15
PT	UC	V	MBH	HE	DS	AS	ATR	GT	GV	SS	SV	TR

1 - Product Type (PT)

D - Indoor HVAC Unit

2 - Unit Configuration (UC)

F - Furnace

3 - Venting (V)

G - Gravity
P - Power

4,5,6- Furnace Input Rating (MBH)

75 - 75,000 Btu/Hr Input
100 - 100,000 Btu/Hr Input
125 - 125,000 Btu/Hr Input
150 - 150,000 Btu/Hr Input
175 - 175,000 Btu/Hr Input
200 - 200,000 Btu/Hr Input
225 - 225,000 Btu/Hr Input
250 - 250,000 Btu/Hr Input
300 - 300,000 Btu/Hr Input
350 - 350,000 Btu/Hr Input
400 - 400,000 Btu/Hr Input

7 - Heat Exchanger/Burner/Drip Pan Material (HE)

A - Aluminized Steel
S - 409 Stainless Steel Heat Exchanger/Burner
T - 409 Stainless Steel Heat Exchanger/Burner/Drip Pan

8 - Development Sequence Designation (DS)

F - Single Stage
M - 2-stage or Modulating

9 - Access Side (AS)

R - Right Hand
L - Left hand

10 - Air Temperature Rise (ATR)

N - Not Used

11- Gas Type (GT)

N - Natural with ignition controller
P - Propane with ignition controller

12 - Gas Valve (GV)

1 - Single Stage
2 - Two Stage
4 - Electronic Modulation Input
5 - Electronic Modulation Master
6 - Electronic Modulation Slave
7 - Electronic Modulation 0-10 Vdc External Input
8 - Electronic Modulation 4-20mA External Input

13 - Additional Safety Switches (SS)

4 - No Switches (Standard)
0 - No Switches (Premium)
1 - Low Gas Pressure Switch (Premium)
2 - High Gas Pressure Switch (Premium)
3 - High and Low Gas Pressure Switch (Premium)

14 - Supply Voltage (SV)

A - 115/60/1
B - 208/60/1
C - 230/60/1
D - 208/60/3
E - 230/60/3
F - 460/60/3
G - 575/60/3

15 - Transformer (TR)

1 - 40 VA
2 - 75 VA
3 - 150 VA
4 - 250 VA
0 - None

Figure 24.1 - Serial Number Designations

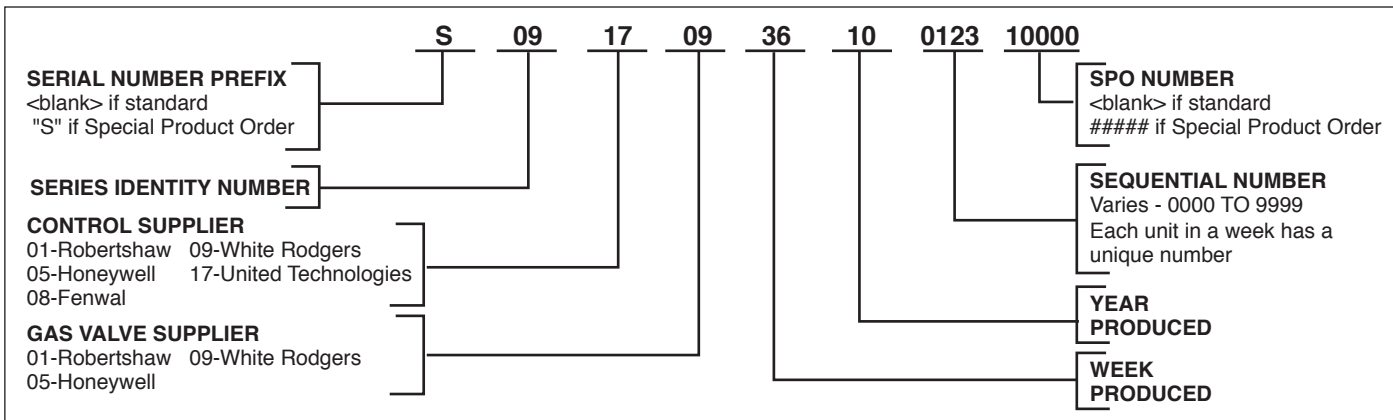

THIS PAGE INTENTIONALLY LEFT BLANK

THIS PAGE INTENTIONALLY LEFT BLANK

THIS PAGE INTENTIONALLY LEFT BLANK

COMMERCIAL WARRANTY

Seller warrants its products to be free from defects in material and workmanship, EXCLUSIVE, HOWEVER, of failures attributable to the use of materials substituted under emergency conditions for materials normally employed. This warranty covers replacement of any parts furnished from the factory of Seller, but does not cover labor of any kind and materials not furnished by Seller, or any charges for any such labor or materials, whether such labor, materials or charges thereon are due to replacement of parts, adjustments, repairs, or any other work done. This warranty does not apply to any equipment which shall have been repaired or altered outside the factory of Seller in any way so as, in the judgment of Seller, to affect its stability, nor which has been subjected to misuse, negligence, or operating conditions in excess of those for which such equipment was designed. This warranty does not cover the effects of physical or chemical properties of water or steam or other liquids or gases used in the equipment.

BUYER AGREES THAT SELLER'S WARRANTY OF ITS PRODUCTS TO BE FREE FROM DEFECT IN MATERIAL AND WORKMANSHIP, AS LIMITED HEREIN, SHALL BE IN LIEU OF AND EXCLUSIVE OF ALL OTHER WARRANTIES, EITHER EXPRESS OR IMPLIED, WHETHER ARISING FROM LAW, COURSE OF DEALING, USAGE OF TRADE, OR OTHERWISE, THERE ARE NO OTHER WARRANTIES, INCLUDING WARRANTY OF MERCHANTABILITY OR FITNESS FOR PURPOSE, WHICH EXTEND BEYOND THE PRODUCT DESCRIPTION CONFIRMED BY BUYER AND SELLER AS OF THE DATE OF FINAL AGREEMENT.

This warranty is void if the input to the product exceeds the rated input as indicated on the product serial plate by more than 5% on gas-fired and oil-fired units, or if the product in the judgment of SELLER has been installed in a corrosive atmosphere, or subjected to corrosive fluids or gases, been subjected to misuse, negligence, accident, excessive thermal shock, excessive humidity, physical damage, impact, abrasion, unauthorized alterations, or operation contrary to SELLER'S printed instructions, or if the serial number has been altered, defaced or removed.

BUYER AGREES THAT IN NO EVENT WILL SELLER BE LIABLE FOR COSTS OF PROCESSING, LOST PROFITS, INJURY TO GOODWILL, OR ANY OTHER CONSEQUENTIAL OR INCIDENTAL DAMAGES OF ANY KIND RESULTING FROM THE ORDER OR USE OF ITS PRODUCT, WHETHER ARISING FROM BREACH OF WARRANTY, NONCONFORMITY TO ORDERED SPECIFICATIONS, DELAY IN DELIVERY, OR ANY LOSS SUSTAINED BY THE BUYER.

BUYER'S REMEDY FOR BREACH OF WARRANTY, EXCLUSIVE OF ALL OTHER REMEDIES PROVIDED BY LAW, IS LIMITED TO REPAIR OR REPLACEMENT AT THE FACTORY OF SELLER, ANY COMPONENT WHICH SHALL, WITHIN THE APPLICABLE WARRANTY PERIOD DEFINED HEREIN AND UPON PRIOR WRITTEN APPROVAL, BE RETURNED TO SELLER WITH TRANSPORTATION CHARGES PREPAID AND WHICH THE EXAMINATION OF SELLER SHALL DISCLOSE TO HAVE BEEN DEFECTIVE; EXCEPT THAT WHEN THE PRODUCT IS TO BE USED BY BUYER AS A COMPONENT PART OF EQUIPMENT MANUFACTURED BY BUYER, BUYER'S REMEDY FOR BREACH, AS LIMITED HEREIN, SHALL BE LIMITED TO ONE YEAR FROM DATE OF SHIPMENT FROM SELLER. FOR GAS-FIRED PRODUCTS INSTALLED IN HIGH HUMIDITY APPLICATIONS AND UTILIZING STAINLESS STEEL HEAT EXCHANGERS, BUYER'S REMEDY FOR BREACH, AS LIMITED HEREIN, SHALL BE LIMITED TO TEN YEARS FROM DATE OF SHIPMENT FROM SELLER.

These warranties are issued only to the original owner-user and cannot be transferred or assigned. No provision is made in these warranties for any labor allowance or field labor participation. Seller will not honor any expenses incurred in its behalf with regard to repairs to any of Seller's products. No credit shall be issued for any defective part returned without proper written authorization (including, but not limited to, model number, serial number, date of failure, etc.) and freight prepaid.

OPTIONAL SUPPLEMENTAL WARRANTY

Provided a supplemental warranty has been purchased, Seller extends the warranty herein for an additional four (4) years on certain compressors. Provided a supplemental warranty has been purchased, Seller extends the warranty herein for an additional four (4) years or nine (9) years on certain heat exchangers.

EXCLUSION OF CONSUMABLES & CONDITIONS BEYOND SELLER'S CONTROL

This warranty shall not be applicable to any of the following items: refrigerant gas, belts, filters, fuses and other items consumed or worn out by normal wear and tear or conditions beyond Seller's control, including (without limitation as to generality) polluted or contaminated or foreign matter contained in the air or water utilized for heat exchanger (condenser) cooling or if the failure of the part is caused by improper air or water supply, or improper or incorrect sizing of power supply.

Component Applicable Models	"APPLICABLE WARRANTY PERIOD"
Heat Exchangers Gas-Fired Units except MPR Models	TEN YEARS FROM DATE OF FIRST BENEFICIAL USE BY BUYER OR ANY OTHER USER, WITHIN TEN YEARS FROM DATE OF RESALE BY BUYER OR ANY OTHER USER, WITHIN TEN YEARS FROM DATE OF RESALE BY BUYER IN ANY UNCHANGED CONDITION, OR WITHIN ONE HUNDRED TWENTY-SIX MONTHS FROM DATE OF SHIPMENT FROM SELLER, WHICHEVER OCCURS FIRST
Heat Exchangers Low Intensity Infrared Units , Gas Heat option on MPR models Compressors Condensing Units for Cassettes	FIVE YEARS FROM DATE OF FIRST BENEFICIAL USE BY BUYER OR ANY OTHER USER, WITHIN FIVE YEARS FROM DATE OF RESALE BY BUYER OR ANY OTHER USER, WITHIN FIVE YEARS FROM DATE OF RESALE BY BUYER IN ANY UNCHANGED CONDITION, OR WITHIN SIXTY-SIX MONTHS FROM DATE OF SHIPMENT FROM SELLER, WHICHEVER OCCURS FIRST
Burners Low Intensity Infrared Units Compressors MPR Models Other Components excluding Heat Exchangers, Coils, Condensers, Burners, Sheet Metal	TWO YEARS FROM DATE OF FIRST BENEFICIAL USE BY BUYER OR ANY OTHER USER, WITHIN TWO YEARS FROM DATE OF RESALE BY BUYER IN ANY UNCHANGED CONDITION, OR WITHIN THIRTY MONTHS FROM DATE OF SHIPMENT FROM SELLER, WHICHEVER OCCURS FIRST
Heat Exchangers/Coils Indoor and Outdoor Duct Furnaces and System Units, Steam/Hot Water Units, Oil-Fired Units, Electric Units, Cassettes, Vertical Unit Ventilators Compressors Vertical Unit Ventilators Burners High Intensity Infrared Units Sheet Metal Parts All Products	ONE YEAR FROM DATE OF FIRST BENEFICIAL USE BY BUYER OR ANY OTHER USER, WITHIN ONE YEAR FROM DATE OF RESALE BY BUYER IN ANY UNCHANGED CONDITION, OR WITHIN EIGHTEEN MONTHS FROM DATE OF SHIPMENT FROM SELLER, WHICHEVER OCCURS FIRST

As Modine Manufacturing Company has a continuous product improvement program, it reserves the right to change design and specifications without notice.



Modine Manufacturing Company
1500 DeKoven Avenue
Racine, WI 53403
Phone: 1.800.828.4328 (HEAT)
www.modinehvac.com