

# **Agilent 700 Series ICP Optical Emission Spectrometers**

## **User's Guide**



**Agilent Technologies**

## Notices

© Agilent Technologies, Inc. 2006, 2009–2013

No part of this manual may be reproduced in any form or by any means (including electronic storage and retrieval or translation into a foreign language) without prior agreement and written consent from Agilent Technologies, Inc. as governed by United States and international copyright laws.

## Manual Part Number

8510230100

## Edition

Seventh edition, May 2013

Printed in Malaysia

Agilent Technologies, Inc.

## Errata Statement

NOTICE: This document contains references to Varian. Please note that Varian, Inc. is now part of Agilent Technologies. For more information, go to [www.agilent.com](http://www.agilent.com).

## Warranty

**The material contained in this document is provided “as is,” and is subject to being changed, without notice, in future editions. Further, to the maximum extent permitted by applicable law, Agilent disclaims all warranties, either express or implied, with regard to this manual and any information contained herein, including but not limited to the implied warranties of merchantability and fitness for a particular purpose. Agilent shall not be liable for errors or for incidental or consequential damages in connection with the furnishing, use, or performance of this document or of any information contained herein. Should Agilent and the user have a separate written agreement with warranty terms covering the material in this document that conflict with these terms, the warranty terms in the separate agreement shall control.**

## Technology Licenses

The hardware and/or software described in this document are furnished under a license and may be used or copied only in accordance with the terms of such license.

## Restricted Rights Legend

If software is for use in the performance of a U.S. Government prime contract or subcontract, Software is delivered and licensed as “Commercial computer software” as defined in DFAR 252.227-7014 (June 1995), or as a “commercial item” as defined in FAR 2.101(a) or as “Restricted computer software” as defined in FAR 52.227-19 (June 1987) or any equivalent agency regulation or

contract clause. Use, duplication or disclosure of Software is subject to Agilent Technologies’ standard commercial license terms, and non-DOD Departments and Agencies of the U.S. Government will receive no greater than Restricted Rights as defined in FAR 52.227-19(c)(1-2) (June 1987). U.S. Government users will receive no greater than Limited Rights as defined in FAR 52.227-14 (June 1987) or DFAR 252.227-7015 (b)(2) (November 1995), as applicable in any technical data.

## Safety Notices

### CAUTION

A **CAUTION** notice denotes a hazard. It calls attention to an operating procedure, practice, or the like that, if not correctly performed or adhered to, could result in damage to the product or loss of important data. Do not proceed beyond a **CAUTION** notice until the indicated conditions are fully understood and met.

### WARNING

A **WARNING** notice denotes a hazard. It calls attention to an operating procedure, practice, or the like that, if not correctly performed or adhered to, could result in personal injury or death. Do not proceed beyond a **WARNING** notice until the indicated conditions are fully understood and met.

# Contents

<b>1. Safety Practices and Hazards</b>	<b>7</b>
General	7
Plasma	8
Heat, Vapors and Fumes	9
Compressed Gas Hazards	9
Electrical Hazards	10
Other Precautions	10
Warning Symbols	12
Color Coding	14
CE Compliance	14
Electromagnetic Compatibility	15
EN55011/CISPR11	15
ICES/NMB-001	16
<b>2. Introduction</b>	<b>17</b>
Site Preparation Requirements	17
User Documentation	18
Conventions	18
Notes and Tips	18
Environmental Conditions	19
Temperature Control	19
Electrical Power Supplies	19
Fuses	19

## Contents

Other Connections	20
Gas Supplies	20
Water Cooling System	22
Drain Vessel	23
<b>3. Installation</b>	<b>25</b>
Personal Computer Requirements	25
ICP Expert II Software	26
PCI-GPIB Communications Card	27
Performing a Dark Current Scan, Wavelength Calibration and Torch Scan	31
Hardware	32
<b>4. Operation</b>	<b>33</b>
Analysis Checklist	34
Turning On the Instrument and Software	34
Turning On the Instrument for the First Time (or From Shutdown Mode)	34
Turning On the Instrument from Standby Mode	35
Preparing for Analysis	36
Calibrating the Detector	37
Aligning the Torch	37
Setting Operating Conditions	37
Creating/Opening a Worksheet	38
Developing a Method	38

Running Samples	38
Printing a Report	38
Turning Off the Instrument	39
Using Standby Mode	39
Using Shutdown Mode	41
<b>5. Maintenance and Troubleshooting</b>	<b>43</b>
Routine	44
Induction Coil Maintenance	46
Radial Induction Coil	47
Axial Induction Coil	48
Cleaning	49
Consumables	49
Troubleshooting	50
Spare Parts	50

## Contents

*This page is intentionally left blank.*

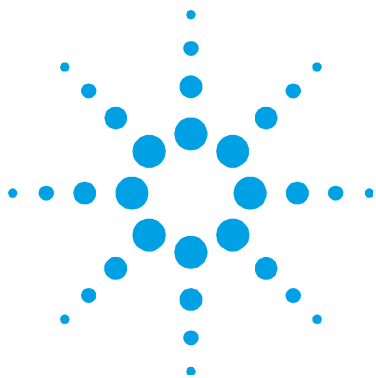

## 1. Safety Practices and Hazards

General	7
Plasma	8
Heat, Vapors and Fumes	9
Compressed Gas Hazards	9
Electrical Hazards	10
Other Precautions	10
Warning Symbols	12
Color Coding	14
CE Compliance	14
Electromagnetic Compatibility	15

### General

Operation of an Agilent 710/715/720/725 Series ICP Optical Emission Spectrometer involves the use of compressed gases, high voltage radio frequency energy and hazardous materials including corrosive fluids and flammable liquids. Careless, improper or unskilled use of this spectrometer can cause death or serious injury to personnel, and/or severe damage to equipment and property.

The spectrometer incorporates interlocks and covers that are designed to prevent inadvertent contact with any potential hazards. If the instrument is used in any manner not specified by Agilent, this protection provided by the equipment may be impaired. It is good practice to develop safe working habits that do not depend upon the correct operation of the interlocks for safe operation. It is essential that no interlock or cover is bypassed, damaged or removed.

The safety practices described below are provided to help the user operate the instrument safely. Read each safety topic thoroughly before attempting to operate the instrument and *always* operate the spectrometer in accordance with these safety practices.

### Plasma

The plasma is extremely hot (about 10,000 K) and radiates dangerous levels of radio frequency (RF) and ultraviolet (UV) energy. The work coil operates at 1,500 V RMS and about 40 MHz. Exposure to the RF and UV energy can cause severe skin damage and cataracts of the eyes, while close contact with the operating plasma can result in severe heat burns to the skin, and an electrical discharge that can jump a considerable distance and may cause death, severe electric shock or sub-surface skin burns.

The plasma must *never* be operated unless:

- the torch compartment door is closed, with the locking lever fully latched; and
- the space above the chimney is clear of objects.

The shielding around the torch compartment is designed to reduce UV, visible and RF radiation to safe levels while still permitting easy access to, as well as installation and viewing of, the torch. The spectrometer has an interlock system that is designed to extinguish the plasma if either the mains supply fails or the handle on the torch compartment door is opened. *Do not* attempt to bypass the interlock system.

Before opening the torch compartment door, *always* extinguish the plasma by pressing F4 on the keyboard or by clicking the 'Plasma Off' icon on the ICP Expert II software toolbar.

The torch and its surroundings remain hot for up to five minutes after the plasma is extinguished. Touching this area before it has cooled sufficiently may result in burns. Allow the torch and torch compartment to cool before carrying out any work in this area, or wear heat-resistant gloves.



The plasma system has been carefully designed to operate safely and effectively when using torches and related components that conform to Agilent's design criteria. Use of non-approved components in the plasma compartment may render the system inoperative and/or hazardous. It may also invalidate the warranty on the instrument. Use only torches and related components supplied or authorized by Agilent.

## Heat, Vapors and Fumes

Heat, ozone, vapors and fumes generated by the plasma can be hazardous, and must be extracted from the instrument by means of an exhaust system. Ensure that an exhaust system of the appropriate type is fitted (as specified in the Site Preparation Guide). The system must be vented to the outside air in accordance with local regulations and never within the building. Regularly check the exhaust system by smoke test to ensure that the exhaust system is functioning correctly. The exhaust fan must always be switched on *before* igniting the plasma.

## Compressed Gas Hazards

All compressed gases (other than air) can create a hazard if they leak into the atmosphere. Even small leaks in gas supply systems can be dangerous. Any leak (except that of air) can result in an oxygen-deficient atmosphere, which can cause asphyxiation. The area in which cylinders are stored and the area surrounding the instrument must be adequately ventilated to prevent such gas accumulations.

Gas cylinders must be stored and handled strictly in accordance with local safety codes and regulations. Cylinders must be used and stored only in a vertical position and secured to an immovable structure or a properly constructed cylinder stand. Move cylinders only by securing them to a properly constructed trolley.

Use only approved regulator and hose connectors (refer to the gas supplier's instructions). Keep gas cylinders cool and properly labeled. (All cylinders are fitted with a pressure relief device that will rupture and empty the cylinder if the internal pressure is raised above the safe limit by excessive temperatures.) Ensure that you have the correct cylinder before connecting it to the instrument.

## Safety Practices and Hazards

The primary gas to be used with the spectrometer is argon, which is the conductive gas for the plasma. Argon or nitrogen can be used as the polychromator purge gas. Other gases may be required for future options and accessories. Use only 'instrument grade' gases with your spectrometer.

If using cryogenic gases (for example, liquid argon), prevent severe burns by wearing suitable protective clothing and gloves.

### Electrical Hazards

The spectrometer system and some accessories contain electrical circuits, devices and components operating at dangerous voltages. Contact with these circuits, devices and components can cause death, serious injury or painful electric shock. Panels or covers which are retained by screws on the spectrometer and accessories may be opened *only* by Agilent-trained, Agilent-qualified or Agilent-approved field service engineers (unless specified otherwise). Consult the manuals or product labels supplied with your personal computer (PC), monitor, printer and water-cooling system to determine which parts are operator-accessible.

Replace blown fuses with ones of the size and rating shown in the text near to the fuse holder.

### Other Precautions

Use of the spectrometer system and accessories may involve materials, solvents and solutions which are flammable, corrosive, toxic or otherwise hazardous. Careless, improper or unskilled use of such materials, solvents and solutions can create explosion hazards, fire hazards, toxicity and other hazards that can result in death, serious personal injury or damage to equipment.

Operation of an ICP-OES involves analysis of solutions that have been prepared in or digested with acids, or in some cases, samples that have been prepared in organic solvents.

The acid concentrations in the sample that is measured is variable, depending upon the digestion steps and acid types used. Instrument users should be aware of the hazards associated with use of the acids used for sample preparation and apply all necessary precautions including use of lab coats, safety goggles and other appropriate forms of personal protection. The acid wastes should be disposed of in accordance with local regulatory requirements.

The type, volatility and concentration of the organic solvents used in the sample that is measured is variable, depending upon the selected solvent and the sample preparation involved. Instrument users should be aware of the hazards associated with use of the organic solvents used for sample preparation, and apply all necessary precautions including ensuring adequate ventilation during use, and use of lab coats, safety goggles, gloves and other appropriate forms of personal protection. The organic wastes should be disposed of in accordance with local regulatory requirements.

Air flow to the cooling fans of the spectrometer and accessories must be unobstructed. Do not block the ventilation grills on the spectrometer and accessories. Consult the manuals supplied with your PC, monitor, printer and water-cooling system for their specific ventilation requirements.

Great care should be taken when working with glass or quartz parts to prevent breakage and cuts. This is especially important when attaching plastic tubing to glass barbs, or removing and replacing pieces of broken torch or bonnet.

The spectrometer weighs approximately 203 kg (448 lb). To avoid injury to personnel or damage to the instrument or property, always use a forklift or other suitable mechanical lifting device to move the instrument.

Use only Agilent-supplied or approved spares with your instrument.

## Warning Symbols

The following is a list of symbols that appear in conjunction with warnings in this manual and on the spectrometer. The hazard they describe is also shown. The beginning of the warning text is noted by a warning icon:

### WARNING

A triangular symbol indicates a warning. The meanings of the symbols that may appear alongside warnings in the documentation or on the instrument itself are as follows:



*Broken glass*



*Corrosive liquids*



*Electrical shock*



*Extreme cold hazard*



*Eye hazard*



*Fire hazard*



*Heavy weight  
(danger to feet)*



*Heavy weight  
(danger to hands)*



*Hot surface*



*Noxious gases*



*RF radiation*

The following symbol may be used on warning labels attached to the instrument. When you see this symbol, refer to the relevant operation or service manual for the correct procedure referred to by that warning label.



The following symbols appear on the instrument for your information.



Mains power on



Mains power off



Fuse



Single phase alternating current



Direct current



When attached to the rear of the instrument, indicates that the product complies with the requirements of one or more EU directives.



'Out' position of a bi-stable push switch.



'In' position of a bi-stable push switch.



Plasma on



Plasma off



'On' for part of equipment.



'Off' for part of equipment.



When attached to the rear of the product, indicates that the product has been certified (evaluated) to CSA 61010.1 and UL 61010-1.

### Color Coding

The various indicator lights appearing on Agilent instruments and associated accessories are color coded to represent the status of the instrument or accessory.

- A green light indicates the instrument is in normal/standby mode.
- An orange light indicates that a potential hazard is present.
- A blue light indicates that operator intervention is required.
- A red light warns of danger or an emergency.

### CE Compliance

Your Agilent 700 Series ICP-OES instrument has been designed to comply with the requirements of the Electromagnetic Compatibility (EMC) Directive and the Low Voltage (electrical safety) Directive (commonly referred to as the LVD) of the European Union. Agilent has confirmed that each product complies with the relevant Directives by testing a prototype against the prescribed EN (European Norm) standards.

Proof that a product complies with these directives is indicated by:

- the CE Marking appearing on the rear of the product, and
- the documentation package that accompanies the product containing a copy of the Declaration of Conformity. The Declaration of Conformity is the legal declaration by Agilent that the product complies with the directives listed above, and shows the EN standards to which the product was tested to demonstrate compliance.

## Electromagnetic Compatibility

### EN55011/CISPR11

**Group 1 ISM equipment:** group 1 contains all ISM equipment in which there is intentionally generated and/or used conductively coupled radio- frequency energy which is necessary for the internal functioning of the equipment itself.

**Class A equipment** is equipment suitable for use in all establishments other than domestic and those directly connected to a low voltage power supply network which supplies buildings used for domestic purposes.

This device complies with the requirements of CISPR11, Group 1, Class A as radiation professional equipment. Therefore, there may be potential difficulties in ensuring electromagnetic compatibility in other environments, due to conducted as well as radiated disturbances.

Operation is subject to the following two conditions:

- 1 This device may not cause harmful interference.
- 2 This device must accept any interference received, including interference that may cause undesired operation.

If this equipment does cause harmful interference to radio or television reception, which can be determined by turning the equipment off and on, the user is encouraged to try one or more of the following measures:

- 1 Relocate the radio or antenna.
- 2 Move the device away from the radio or television.
- 3 Plug the device into a different electrical outlet, so that the device and the radio or television are on separate electrical circuits.
- 4 Make sure that all peripheral devices are also certified.

## Safety Practices and Hazards

- 5 Make sure that appropriate cables are used to connect the device to peripheral equipment.
- 6 Consult your equipment dealer, Agilent Technologies, or an experienced technician for assistance.
- 7 Changes or modifications not expressly approved by Agilent Technologies could void the user's authority to operate the equipment.

### **ICES/NMB-001**

This ISM device complies with Canadian ICES- 001.

Cet appareil ISM est conforme à la norme NMB-001 du Canada.



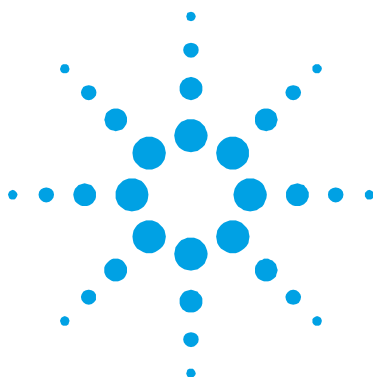

## 2. Introduction

Site Preparation Requirements	17
User Documentation	18
Environmental Conditions	19
Electrical Power Supplies	19
Other Connections	20
Gas Supplies	20
Water Cooling System	22
Drain Vessel	23

### Site Preparation Requirements

Prior to receiving your instrument you will have been provided with an Agilent 700 Series ICP Optical Emission Spectrometer Site Preparation Guide, which describes the environmental and operating requirements of the ICP-OES system. You must prepare your laboratory according to these instructions before the ICP-OES can be installed. You should keep the Site Preparation Guide for future reference for example, if you plan to move your instrument. If you have misplaced your copy, you can obtain a free replacement from your local Agilent office.

Position the equipment for easy access to the disconnecting switch on the rear of the instrument.

### User Documentation

You have been provided with the following documentation to help you set up and operate your Agilent ICP-OES system:

- This operation manual, with safety practices and hazards information, instructions for finding information about installing and maintaining the components of the ICP-OES and a brief operation overview.
- An extensive Help system containing context-sensitive Help, step-by-step instructions for frequently performed operations and instructions for using any accessories you ordered.

### Conventions

The following conventions have been used throughout the documentation:

- Menu items, menu options and field names (for example, click **Copy** from the **Edit** menu) have been typed in bold. Bold is also used to signify the pushbuttons appearing throughout the software (e.g., click **OK**).
- ALL CAPITALS indicate keyboard and mouse commands (e.g., press the F2 key) and text you must type in from the keyboard (e.g., type SETUP at the prompt).
- References to the ICP-OES instrument are applicable to all models (Agilent 710/715/720/725 Series ICP-OES) unless otherwise stated.

### Notes and Tips

A Note is used to give advice or information.

A Tip is used to give practical hints to help you achieve the best possible performance from your ICP-OES.

## Environmental Conditions

The instrument is suitable for indoor use *only* and is classified suitable under the following categories (EN 61010-1):

- Installation category II
- Pollution degree 2
- Equipment class I

## Temperature Control

For *optimum analytical performance*, it is recommended that the ambient temperature of the laboratory be between 20 and 25 °C (68 and 77 °F), and be held constant to within  $\pm 2$  °C ( $\pm 3.6$  °F) throughout the entire working day.

## Electrical Power Supplies

For electrical requirements, refer to your Agilent 700 Series ICP Optical Emission Spectrometers Site Preparation Guide.

### Fuses

**1FS1 and 1FS2**      T6.3 AH 250 V, IEC 127 sheet 5, 5 x 20 mm

**1CB1**                Circuit breaker 30 A Fast trip

#### NOTE

For safety reasons, any other internal fuse or circuit breaker is not operator accessible, and should only be replaced by Agilent-authorized personnel.

---

Fuse information on the rear of the instrument is the most up to date.

## Other Connections

IEEE 488

**NOTE**

Basic insulation is provided for single fault protection on the IEEE connector.

## Gas Supplies

The installation of compressed or liquid gas supplies must comply with the rules and/or regulations imposed by the local authorities responsible for such use in the workplace.

Liquid or gaseous argon and nitrogen may be used with Agilent ICP-OES spectrometer systems. Agilent recommends the use of liquid gases, which are more pure, more convenient and cheaper per unit volume.

The main gas supply requirement is argon for supply to the plasma, nebulizer and optics interface purge. Gas is also required to purge the polychromator assembly, and this may be either argon or nitrogen. A separate gas line connects internally to the argon supply unless the optional nitrogen purge kit is fitted (either factory or field fitted).

**Table 1.** Gas requirements

	<b>Argon</b>	<b>Nitrogen</b>
<b>Purity</b>	99.996%	99.996%
<b>Oxygen</b>	<5 ppm	<5 ppm
<b>Nitrogen (argon only)</b>	<20 ppm	-
<b>Water vapor</b>	<4 ppm	<4 ppm
<b>Permissible pressure range</b>	400–600 kPa (57 to 88 psi)	
<b>Recommended pressure</b>	550 kPa (80 psi) regulated	

**Table 2.** Typical flow rates for the Agilent 700 Series ICP-OES instruments

	<b>Argon (with argon purge gas)</b>	<b>Nitrogen (as purge gas)</b>
Standby mode	0.75 L/min	Nitrogen flow 0.45 L/min
Operational range (plasma on)	9–32.8 L/min	Argon flow 8.3–29.1 L/min Nitrogen flow 0.45–2.1 L/min
<b>Typical Flows</b>		
Measuring wavelengths > 200 nm (poly boost off)	13.5 to 21.75 L/min	Argon flow 12.75 – 21 L/min Nitrogen flow 0.45 L/min
Measuring wavelengths < 200 nm (poly boost on)	15.75 – 24 L/min	Argon flow 12.75 – 21 L/min Nitrogen flow 2.1 L/min

The spectrometer is fitted with PTFE gas supply hose assemblies, 1.8 meters (6 feet) in length fitted with Swagelok hardware. Gas supply adapters are included with each instrument to connect the instrument to regulated gas supplies.

The user (or other authorized personnel) must carry out appropriate leak tests necessary to ensure safety on the gas and liquid connections that the operator is directed to assemble during installation, normal use or maintenance.

### Storage Cylinder Instructions

Cylinders containing gas under pressure should be firmly secured to a rigid structure, and the storage area must be adequately ventilated.

Never locate gas cylinders near a source of ignition, or in a position that is subject to direct heat. Gas storage cylinders often incorporate a pressure release device, which will discharge the gas at a predetermined temperature, usually around 52 °C (125 °F).

If gases are to be plumbed from a remote storage area to the instrument site, ensure that the local outlets are fitted with stop valves, pressure gauges and suitable regulators, which are easily accessible to the instrument operator. The gas outlets must be provided within 1.5 meters (5 feet) of the instrument.

### Cryogenic Liquids

Cryogenic liquid gases are stored under pressure at very low temperatures in Portable Liquid Cylinders (PLCs).

---

#### WARNING



#### Extreme Cold Hazard

Contact with the super-cold liquid, gas or pipe surfaces can cause severe skin damage. The PLCs should be located in a shielded position, and all piping should be routed or covered to prevent skin contact.

---

For high gas flow rates and/or low ambient temperatures, it may be necessary to obtain the gas by passing the liquid through an external evaporator rather than use the internal pressure building facility of the PLCs.

Liquid argon and liquid nitrogen may *not* be stored for extended periods and often have special storage requirements. Contact your local authorities and cryogenic gas supplier for more detailed information on storage requirements and boil-off rates for local types of PLCs.

### Water Cooling System

Agilent ICP-OES instruments require a source of cooling water. Refer to the Site Preparation Guide for compatible water cooling systems.

#### NOTE

The operation manual, mounting and assembly hardware for the cooling system are included in the water cooler packaging. Care should be exercised to locate all of these articles before the pack is discarded.

---

#### NOTE

Pressure regulation is recommended for supplies where the cooling water pressure may be subject to fluctuations. Pressure regulation is necessary for supplies that may exceed the maximum permissible pressure of 310 kPa (45 psi).

---

The instrument is equipped with a water flow sensor, which will stop operation of the plasma and camera Peltier assembly if the cooling water flow through the instrument drops below 1.1 L/min (0.3 gpm).

**CAUTION**

Always ensure the water cooling system is on before igniting the plasma.

Provided that the flow rate can be maintained above 1.1 L/min and maximum supply pressure is below 310 kPa (45 psi), the cooling water supply may be taken from an in-house domestic water system, if local regulations permit.

An alternative is to install a recirculating water cooler system. The system should provide cover for the reservoir to prevent evaporation and stop contamination by dust or other impurities. Algicide should be used.

A recirculating water cooling system has the advantage of reducing the volume of water that will be required over the life of the instrument's operation. Because of the limited size of the water cooler's reservoir, in the case of accidental damage, the amount of water damage that can occur will also be limited.

## Drain Vessel

The Agilent ICP-OES system needs a drain vessel for disposal of excess fluids and vapors from the spraychamber. Suitable tubing is supplied with the spectrometer for use with inorganic solvents. When using organic solvents, different drain tubing that is suitable for the solvent in use will be required.

A chemically inert container, not glass or of a narrow-necked style, to hold a minimum of 2 liters (4 pints) of waste must be provided by the user. It should be located underneath the sample compartment (or on the right side of the instrument), where it is protected by the bench and in full view of the operator.

*This page is intentionally left blank.*



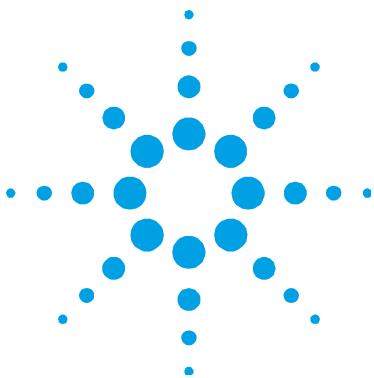

### 3. Installation

Personal Computer Requirements	25
ICP Expert II Software	26
PCI-GPIB Communications Card	27
Performing a Dark Current Scan, Wavelength Calibration and Torch Scan	31
Hardware	32

The Agilent 700 Series ICP-OES must be installed by an Agilent-trained, Agilent-qualified or Agilent-authorized field service engineer.

You should have completed and returned the form in the Site Preparation Guide stating that you have prepared the laboratory in accordance with the requirements detailed in that manual. An Agilent representative will then arrange a suitable installation date with you.

Details for unpacking the instrument and what to do in case it has been damaged in transit are also outlined in the Site Preparation Guide.

#### Personal Computer Requirements

The recommended PC specifications are listed in the Agilent 700 Series ICP Optical Emission Spectrometers Site Preparation Guide.

### ICP Expert II Software

The Agilent-trained, Agilent-qualified or Agilent-authorized field service engineer will install the ICP Expert II software for you during the installation process. However, you may need to install the software yourself at some later stage, for example if you change the PC. Instructions are provided.

**There are several installation scenarios:**

- Standalone Flat File for Microsoft Windows 7 or Windows XP
- Standalone Database for Microsoft Windows 7
- Network Database for Microsoft Windows 7
- Upgrading Standalone or Network Database ICP Expert II installations for Microsoft Windows 7 or Windows XP

**Installation includes:**

- Installing the ICP Expert II software
- Installing the ICP Expert II Help
- Installing the PCI-GPIB communications card
- Installing and configuring VSDA (if using the database file format and saving data over a network)
- Installing and configuring SCM (for 21 CFR Part 11 compliance)
- Complete the dark current scan, wavelength calibration and torch scan

**For instructions on how to install your ICP Expert II software, refer to the documentation provided with your software:**

- ICP Expert II Windows 7 64-bit (SP1) Software Installation Instructions
- ICP Expert II Windows XP 32-bit (SP3) Software Installation Instructions
- ICP Expert II Software Installation Instructions for 21 CFR Part 11 Environments for Windows 7 64-bit (SP1) only

Once you have installed the appropriate software, install the PCI-GPIB communications card (see below) and then perform the Dark Current Scan, Wavelength Calibration and Torch Scan (see Page 31).

## PCI-GPIB Communications Card

The National Instruments PCI-GPIB card must be installed in your PC to interface the PC and ICP-OES instrument.

### NOTE

Although the Agilent-trained, Agilent-qualified or Agilent-authorized field service engineer will install the GPIB communications device for you during the installation process, you may need to reinstall it yourself at some later stage, for example if you change the PC.

### CAUTION

The components on the communications card and in the PC are highly static-sensitive. To avoid damaging these components you must drain any static charges from your body before installing the board, and prevent the generation of any new static charges during the installation. This can be done by wearing an ESD (electrostatic discharge) wrist strap attached to a grounding point. You can obtain a disposable ESD strap from Agilent; or you can obtain one from your local electronics supplier.

### To install a National Instruments PCI-GPIB communications card:

- 1 Turn off and unplug the computer.
- 2 Remove the cover, following the instructions in the manual provided with the computer.

## Installation

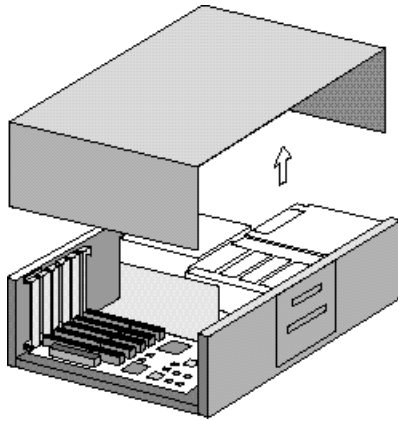

**Figure 1.** Removing the PC cover

- 3** Attach one end of the ESD strap to a bare metal part of the PC chassis and wrap the other end around your wrist.

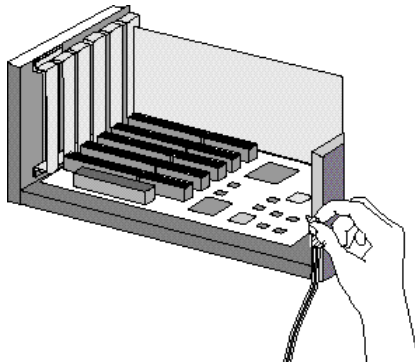

**Figure 2.** Attaching the ESD strap to a metal part of the PC

- 4** Remove a blanking plate from one of the empty slots in the computer.

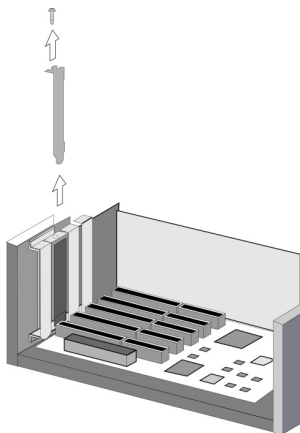

**Figure 3.** Removing a blanking plate from an empty PC slot

- 5 Remove the card from its static-shielded packaging. Do not touch the gold edge connectors.

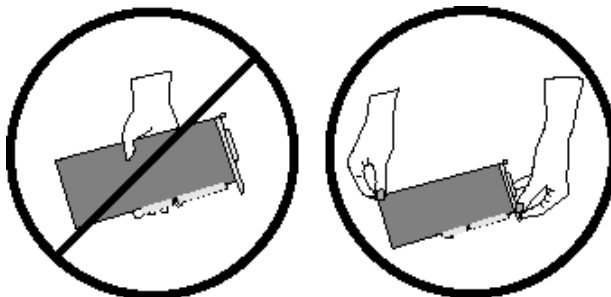

**Figure 4.** Incorrect and correct way to handle the card

- 6 Press the card firmly into the empty PC slot. The gold edge connectors should slide firmly into the matching sockets of the PC slot. Secure the card with the screw.

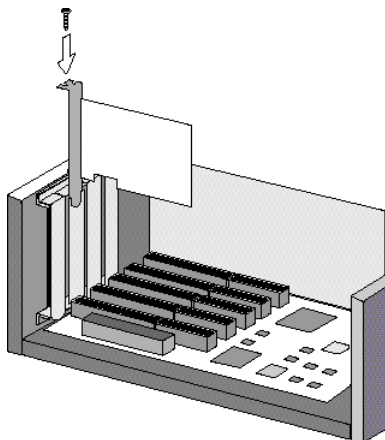

**Figure 5.** Sliding the card into an empty slot

- 7 Replace the computer cover.

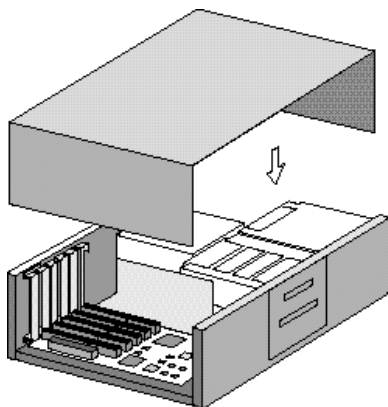

**Figure 6.** Replacing the PC cover

- 8 Connect the cable between the instrument and the computer (one end plugs into the interface board in the computer, and the other plugs into the socket in the rear of the instrument).
- 9 Connect the computer to the mains power.
- 10 Turn the computer on and log on as an administrator.

## Performing a Dark Current Scan, Wavelength Calibration and Torch Scan

**To perform a dark current scan, wavelength calibration and torch scan:**

- 1** Start the ICP Expert II software and open the Instrument Set-up Window.
- 2** Ignite the plasma.
- 3** Check that the Polychromator Boost purge is on.
  - a** Click the **Status** tab and check that under the Polychromator listing Poly Boost is 'On'.
  - b** If the Poly Boost purge is 'Off' you should turn it on.
  - c** Choose **PolyBoost On** from the Analyze menu in the main window.
  - d** Reopen the Instrument Setup window.
  - e** Leave the poly boost purging for at least 20 minutes prior to performing Step 7 below (the wavelength calibration).
- 4** Aspirate a blank solution and then select the **W/L Calib** tab.
- 5** If you have a 710/715 Series ICP-OES, click **Calibrate Detector** to perform a dark current scan.  
If you have a 720 Series ICP-OES, click **Dark Current Scan** to perform a dark current scan.

**NOTE**

It will take roughly 2 minutes to perform a Dark Current Scan. Once completed, a message will be displayed confirming the dark current measurement has been completed.

- 
- 6** Click **Store Dark Current**.

**NOTE**

It is recommended that you save the results using the default entries in a text file called "Dark Current.txt" in the Users\Public\Public Documents\Varian\ICP Expert II\Log directory on the drive on which the ICP Expert II software is installed.

## Installation

- 7 Aspirate the wavelength calibration solution. Select the **W/L Calib** tab.  
If you have a 710/715 Series ICP-OES, click **Calibrate Wavelength** to perform a wavelength calibration.  
If you have a 720 Series ICP-OES, click **Calibrate** to perform a wavelength calibration.

### NOTE

It will take up to 2 to 3 minutes to perform a Wavelength Calibration. Once completed, a message will be displayed confirming the wavelength calibration is complete, and the range of wavelengths over which the instrument has been calibrated.

- 
- 8 Click the **Torch Align** tab. Check that the Graph Type is set to **Intensity**. Set the Orientation to **Horizontal** and click the **Torch Scan** button.

### NOTE

The signal (Intensity or SRBR) as a function of the torch viewing position will be displayed. The highest point in the scan is identified by the software, and the corresponding viewing position value is stored and used for all subsequent measurements.

- 
- 9 If you have an ICP-OES with an axially oriented plasma, change the setting or 'Orientation' to **Vertical** and click **Torch Scan** again. If you have an ICP-OES with a radially oriented plasma, this step is not required.

## Hardware

Your ICP-OES should be ready to operate after the Agilent field service engineer has installed it. However, you may need to set up items such as the peristaltic pump, nebulizer, torch or spraychamber. For instructions on how to do this, please refer to the Help. Click **Start > Programs > ICP Expert II > ICP Expert II Help**.

When the ICP Expert II Help appears, click **How to > Install instrument components** to view step-by-step instructions on how to remove and install the various instrument components.



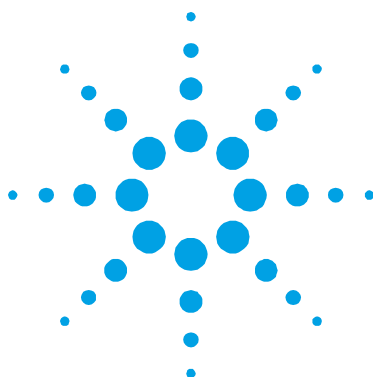

## 4. Operation

Analysis Checklist	34
Turning On the Instrument and Software	34
Preparing for Analysis	36
Calibrating the Detector	37
Aligning the Torch	37
Setting Operating Conditions	37
Creating/Opening a Worksheet	38
Developing a Method	38
Running Samples	38
Printing a Report	38
Turning Off the Instrument	39

This chapter provides a quick guide to getting the instrument set up and running samples.

You will find step-by-step instructions for common operations in the ICP Expert II Help. To access this information:

- 1 Select the Windows **Start** button and choose **Programs > ICP Expert II > ICP Expert II Help**.
- 2 When the ICP Expert II Help appears, click **How to** to view the available step-by-step instructions.

### Analysis Checklist

You need to complete the following steps in turn to measure a sample/s. You will find information on each step in this chapter.

- Turn on the instrument and software
- Prepare for analysis
- Calibrate the detector
- Align the torch
- Set operating conditions
- Create/open a worksheet
- Develop a method
- Run samples
- Print a report

### Turning On the Instrument and Software

Before starting the system, carefully read the Safety practices and hazards section at the front of this manual and ensure that the laboratory is set up according to the details specified in the Site Preparation Guide.

#### Turning On the Instrument for the First Time (or From Shutdown Mode)

**To turn on the instrument for the first time or from Shutdown mode:**

- 1 Check that all tubing on the torch, spraychamber, nebulizer and peristaltic pump is correctly connected.
- 2 Close the torch compartment door, ensuring that the locking lever is fully latched.
- 3 Switch on the computer, monitor and printer.
- 4 Switch on the water cooler.
- 5 Turn on the gas supply at the cylinder.

- 6 Plug the cable into the wall socket and set the switch to 'On'.
- 7 To turn on the spectrometer, set the RF supply circuit breaker located on the right rear side of the instrument to the 'On' (up) position.
- 8 Set the instrument power switch, located at the front left of the instrument, to 'I' (the green power indicator should light).

**NOTE**

Both the RF supply circuit breaker and instrument power switch must be switched on for the instrument to work.

- 
- 9 Switch on the laboratory exhaust system.
- 

**WARNING****Hot Surfaces and Noxious Fumes**

**Burn danger, inhalation hazard. The plasma emits heat, ozone and fumes, which can be hazardous. Always switch on the exhaust system before lighting the plasma.**

- 
- 10 To start the ICP Expert II software, click **Start > All Programs > ICP Expert II > ICP Expert II**. The Main Index window will appear.

**Turning On the Instrument from Standby Mode****To turn on the instrument from Standby mode:**

- 1 Check that all tubing on the torch, spraychamber, nebulizer and peristaltic pump is correctly connected.
- 2 Close the torch compartment door, ensuring that the locking lever is fully latched.
- 3 Switch on the monitor and printer (if they are off).
- 4 Switch on the water cooler (if it is off).

## Operation

- 5 The Peltier will switch on automatically. If for some reason it has been turned off, switch on the Peltier by choosing **Peltier on** from the **Analyze** menu.

### NOTE

You can check if the Peltier is on by looking at the Instrument Setup window Status page. It may take some time to reach operating temperature. It is recommended that you wait three to five minutes before starting an analysis.

- 
- 6 If you have accessories fitted, switch them on.
  - 7 Switch on the laboratory exhaust system.

### WARNING



#### Hot Surfaces and Noxious Fumes

**Burn danger, inhalation hazard. The plasma emits heat, ozone and fumes which can be hazardous. Always switch on the exhaust system before lighting the plasma.**

---

## Preparing for Analysis

For detailed information on how to prepare your instrument for analysis which includes setting up the peristaltic pump tubing and turning on the plasma, see the ICP Expert II Help:

- 1 Click **Start > All Programs > ICP Expert II > Help**.
- 2 Expand **How to** and then click **Prepare the instrument for use**.

## Calibrating the Detector

For detailed information on how to prepare the calibration solution and perform the wavelength calibration procedure see the ICP Expert II Help:

- 1 Click **Start > All Programs > ICP Expert II > Help**.
- 2 Expand **How to**, and then expand **Prepare the instrument for use**.
- 3 Click **Prepare the wavelength calibration solution** to make the required solution.
- 4 Click **Perform a wavelength calibration**.

## Aligning the Torch

You now need to align the torch viewing position before using a new method. For detailed information on how to align the torch, see the ICP Expert II Help:

- 1 Click **Start > All Programs > ICP Expert II > Help**.
- 2 Expand **How to**, and then expand **Prepare the instrument for use**.
- 3 Click **Perform a torch alignment scan**.

## Setting Operating Conditions

You now need to find, and set, the optimum operating conditions. For detailed information, see the ICP Expert II Help:

- 1 Click **Start > All Programs > ICP Expert II > Help**.
- 2 Expand **How to**, and then expand **Prepare the instrument for use**.
- 3 Click **Set the operating conditions**.

### Creating/Opening a Worksheet

For detailed information on how to create a new worksheet or open an existing one see the ICP Expert II Help:

- 1 Click **Start > All Programs > ICP Expert II > Help**.
- 2 Expand **How to** and then expand **Load a worksheet**.

### Developing a Method

For detailed information and tutorials on how to develop a method which includes selecting the elements, setting up the standards and adding any required additional information, see the ICP Expert II Help:

- 1 Click **Start > All Programs > ICP Expert II > Help**.
- 2 Expand **How to** and then click **Develop a method**.

### Running Samples

For detailed information and tutorials on how to run samples, which includes setting up the sequence and sequence parameters, see the ICP Expert II Help:

- 1 Click **Start > All Programs > ICP Expert II > Help**.
- 2 Expand **How to** and then click **Run an analysis**.

### Printing a Report

Once your analysis is complete, you can preview or print a report of your results or export your results. See the ICP Expert II Help for detailed instructions:

- 1 Click **Start > All Programs > ICP Expert II > Help**.
- 2 Expand **How to** and then click **Report your results**.

## Turning Off the Instrument

There are two modes of turning off your ICP-OES. For day-to-day use, it is recommended that the instrument be set to Standby mode (which keeps the polychromator thermostating system and purge systems operational). When the ICP-OES is not going to be in use for prolonged periods, the Shutdown mode may be used (which turns off all purging as well as the polychromator thermostating system).

### Using Standby Mode

**To set the instrument to Standby mode:**

- 1 Rinse the spraychamber by aspirating water for a few minutes.

---

**NOTE**

When running organic samples it is recommended that the spraychamber be cleaned and dried thoroughly between analyses.

- 2 Extinguish the plasma by clicking the **Plasma Off** icon, pressing F4 on the keyboard or choosing **Plasma Off** from the **Analyze** menu. The peristaltic pump stops automatically when the plasma is extinguished.

---

**NOTE**

The yellow Plasma emergency off button, located next to the mains power switch on the front of the instrument, is designed to be used only in an emergency—for example if the torch is melting. It is not intended to be used every time you want to extinguish the plasma. If used to extinguish the plasma, you will need to reset the Plasma emergency off button to the 'on' position before the plasma can be re-ignited.

- 3 Leave the mains power switch on to keep the polychromator thermostating system operational.

## Operation

- 4 To save on argon costs, you can turn the polychromator boost off overnight, by choosing **PolyBoost off** from the **Analyze** menu. This is not recommended if you are routinely analyzing lines below 190 nm, as the instrument will take some time to stabilize when the polychromator boost is turned on again.
- 5 To increase the pump tubing lifetime, loosen the peristaltic pump tubes by releasing the pressure bars and lift the tubes out of the grooves. To do this:
  - a Push up the pressure bar screws. This releases them from the resting bar (refer to Figure 8).
  - b Allow the resting bar to swing downwards.
  - c Lift the tubing out of the grooves.

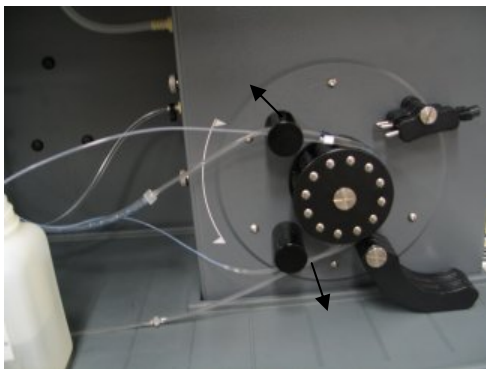

**Figure 7.** Peristaltic pump with pressure bars pushed up and resting bar freely down, allowing tubing to be loosened

### NOTE

Newer models of the peristaltic pump have a peg that the resting bars sit on instead of resting on the instrument.

- 
- 6 It is recommended that you switch off the water cooler.

### NOTE

If the water cooler is turned off, the Peltier will automatically turn off.

---



Close the worksheet by clicking 'Close' from the 'File' menu but leave the ICP Expert II software running. You may switch off the printer, monitor and any accessories if desired.

Ensure that the powersave option on your PC is disabled (this will prevent the shutdown of your hard disk). If this option is not disabled, you could lose data during an unexpected shutdown.

---

**WARNING****Noxious Fumes**

**Inhalation danger. The exhaust system MUST remain on if the gas supplies are on.**

---

**Using Shutdown Mode**

**To shut down your instrument:**

- 1 Rinse the spraychamber by aspirating water for a few minutes.

**NOTE**

When running organic samples it may be necessary to disconnect the spraychamber and clean and dry it thoroughly between analyses.

---

- 2 Extinguish the plasma by clicking the **Plasma Off** icon, pressing F4 on the keyboard or choosing **Plasma Off** from the **Analyze** menu. The peristaltic pump stops automatically when the plasma is extinguished.

**NOTE**

The yellow Plasma emergency off button, located next to the mains power switch on the front of the instrument, is designed to be used only in an emergency—for example if the torch is melting. It is not intended to be used every time you want to extinguish the plasma.

If used to extinguish the plasma, you will need to reset the Plasma emergency off button to the 'on' position before the plasma can be re-ignited.

---

- 3 Turn off the Peltier by choosing **Peltier Off** from the **Analyze** menu.

### CAUTION

The ICP-OES gas control unit supplies uninterrupted gas purge to the polychromator assembly to minimize the ingress of moisture. It is strongly recommended that gas supplies be left on at all times except during long periods of non-use.

---

- 4** Switch off the mains power switch (the green light will go off). This will turn off the complete instrument, including the Peltier (if not done so manually earlier) as well as the polychromator thermostating system.
- 5** Loosen the peristaltic pump tubes by releasing the pressure bars and lift the tubes out of the grooves. To do this:
  - a** Push up the pressure bar screws. This releases them from the resting bar (refer to Figure 8).
  - b** Allow the resting bar to swing downwards.
  - c** Lift the tubing out of the grooves.
- 6** Switch off the water cooler, laboratory exhaust system and any accessories (where applicable), and shut down the argon gas supply at the cylinder.
- 7** Exit the ICP Expert II software, if it is no longer required, by choosing **Exit** from the **File** menu. Switch off the printer and monitor.
- 8** Restarting the instrument will take several hours due to gas purge and polychromator thermal stabilization time.

### NOTE

If the instrument is not going to be in use for a period of time the torch, cone, snout and torch compartment should be cleaned of any deposits, dirt or residue.

---

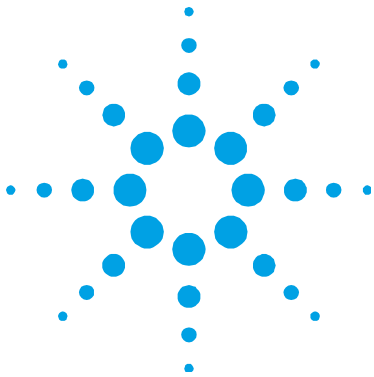

## 5. Maintenance and Troubleshooting

Routine	44
Induction Coil Maintenance	46
Cleaning	49
Consumables	49
Troubleshooting	50
Spare Parts	50

This chapter includes the Agilent 700 Series ICP optical emission spectrometer maintenance requirements that may be carried out by an operator. Any maintenance procedures not specifically mentioned in this chapter should be carried out only by Agilent-trained, Agilent-qualified or Agilent-authorized field service engineers.

### WARNING



#### Eye Hazard

**Danger to eyes. The plasma is an intense light source. Direct viewing of the light source will cause eye damage. Operators and other unauthorized personnel must NEVER remove the main covers or disable the safety interlock system.**

### WARNING



#### Shock Hazard

**This instrument contains electrical circuits, devices and components operating at dangerous voltages. Contact with these circuits, devices and components can result in death, cause serious injury, or painful electrical shock.**

### WARNING



#### RF Hazard and Hot surfaces

The plasma radiates dangerous levels of radio frequency (RF) energy. Exposure to the RF energy can cause severe skin damage and cataracts of the eyes, while close contact with the operating plasma can result in severe heat burns to the skin, and an electrical discharge which can jump a considerable distance and may cause death, severe electric shock or sub-surface skin burns.

---

### NOTE

This section refers to maintenance procedures for the ICP-OES instrument. You should refer to your PC and printer manuals for their maintenance procedures, and to the ICP Expert II Help for the maintenance procedures for any accessories you ordered.

---

## Routine

The following parts of the ICP-OES require routine maintenance. Maintenance instructions are included in the ICP Expert II Help. To access these instructions, click **Start > All Programs > ICP Expert II > ICP Expert II Help**. Click the **Maintenance** link.

### Hourly

- Check and, if necessary, empty the drain vessel.

### Daily

- Check the water level in the Argon Saturator Accessory (ASA) before every use (if applicable).
- Clean the surface of your ICP-OES (spills should be cleaned up immediately).
- Inspect the pump tubing and replace if it has lost its elasticity. Unclip the pump tubes when the pump is not in use.

### Weekly

- ❑ Clean the torch.
- ❑ Clean the cone (710/720 ICP-OES instruments).
- ❑ Clean the snout (715/725 ICP-OES instruments).
- ❑ Clean the bonnet (715/725 ICP-OES instruments).
- ❑ Clean the spraychamber.
- ❑ Clean the nebulizer.

### Monthly

- ❑ Clean the cooling air intake filter on top of your instrument.
- ❑ Inspect the state of the induction coil. Contact your local Agilent office or representative if maintenance is required. See the following section for additional information.
- ❑ Remove and clean the water filter on the back of the instrument.
- ❑ Check the water level in the water cooler (refer to the manual supplied with the water cooler for details).
- ❑ Check/clean the heat exchanger (radiator) on the cooling system to remove any build-up of dust and dirt.
- ❑ Periodically, drain the coolant from the cooling system and then refill/ treat with an appropriate algaecide (as recommended by the manufacturer).
- ❑ Perform a wavelength calibration.
- ❑ Inspect the external gas supply system for leaks including the tubing connected to the instrument. Replace any damaged, leaking or worn components.

### Induction Coil Maintenance

The induction coil transfers energy from the RF generator to the plasma. A deformed coil will distribute the RF energy unevenly to the plasma and may cause the torch or torch clamp to melt. If you suspect the coil has been damaged, you should arrange a service call to replace the coil.

#### NOTE

Due to the specialized expertise needed for the proper service of induction coils, it is strongly recommended that the induction coil be serviced only by an Agilent field service engineer. In addition to the safety hazards identified below, improper service may cause performance degradation and may invalidate your warranty.

#### WARNING



##### Fire Hazard

Operating your Agilent ICP-OES instrument with a deformed induction coil could cause the torch and/or torch lamp to overheat, which could create a risk of fire. Failure to ensure the induction coil is properly maintained and positioned could therefore result in personal injury or damage to the instruments and/or other property.

#### WARNING



##### Hot surfaces

The torch and torch compartment become extremely hot during instrument operation and remain hot for some time after the plasma has been extinguished. Allow the torch and torch compartment to cool for at least five minutes before inspecting the induction coil. Wear heat-resistant gloves.

#### CAUTION

Take care not to touch the induction coil when installing torches or the snout (Agilent 715/725 ICP-OES radial instruments only).

For a uniform RF field, and to ensure the best performance from your spectrometer, the torch should be positioned in the middle of the induction coil and the coils should be uniformly spaced around the torch.

Check that the loops of the coil are aligned with respect to each other (running in parallel) and that the turn-to-turn separation (the pitch) of neighboring loops lies within the specified tolerance for your instrument type:

- Radial induction coil (Agilent 715/725 ICP-OES radial instruments only)
- Axial induction coil (Agilent 710/720 ICP-OES axial instruments only)

### Radial Induction Coil

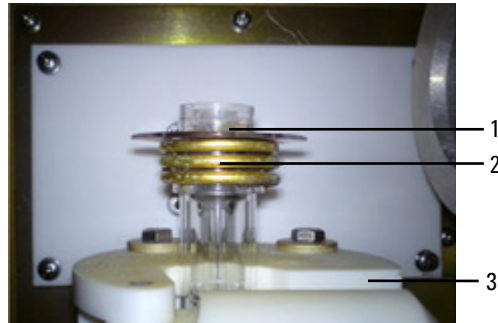

**Figure 8.** Induction coil—radial where 1. Torch, 2. Induction coil and 3. Torch clamp

### Pitch of Radial Induction Coil

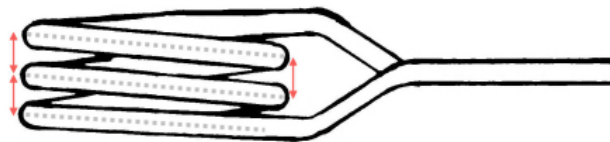
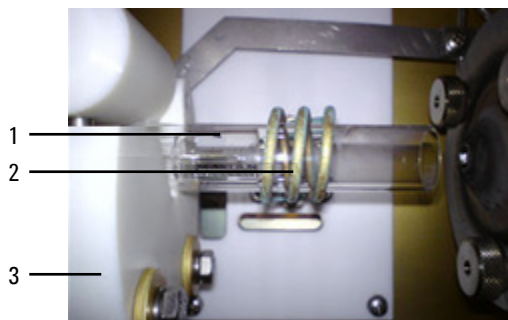

**Figure 9.** Pitch measurement—a radial induction coil must have a pitch (↕) of  $4.7 \pm 0.5$  mm

#### NOTE

Pitch is measured from the center of one coil to the next, as shown above by the arrows between the dotted gray lines, and *not* the gap between adjacent coils.

### Axial Induction Coil



**Figure 10.** Induction coil — axial where 1. Torch, 2. Induction coil and 3. Torch clamp

### Pitch of Axial Induction Coil

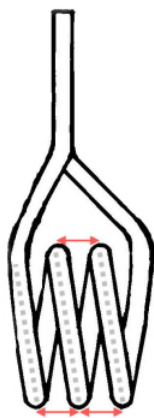

**Figure 11.** Pitch measurement — an axial induction coil must have a pitch (↔) of  $7.5 \pm 0.5$  mm

**NOTE**

Pitch is measured from the center of one coil to the next, as shown above by the arrows between the dotted gray lines, and *not* the gap between adjacent coils.



## Cleaning

Any spills in the sample compartment should be wiped up immediately.

The user (or other authorized personnel) must perform the appropriate decontamination procedure if hazardous material is spilled on or inside the ICP-OES.

The exterior surfaces of the ICP-OES should be kept clean. All cleaning should be done with a soft cloth. If necessary, this cloth can be dampened with water or a mild detergent. Do not use organic solvents or abrasive cleaning agents.

Before using any cleaning agent, procedure or decontamination method except those specified by Agilent, the user (or other authorized personnel) should check with your local authorized Agilent field service engineer or representative to confirm that the proposed method will not damage the equipment.

## Consumables

For information on maintaining consumables (such as replacing the torch, cleaning the cone, replacing the peristaltic pump tubes and replacing fuses), refer to the Help. Specifically:

- 1 Click **Start > All Programs > ICP Expert II > ICP Expert II Help**.
- 2 When the ICP Expert II Help appears, click **Maintenance** to view step-by-step instructions on how to maintain instrument consumables.

### Troubleshooting

For troubleshooting information, please see the ICP Expert II Help:

- 1 Click **Start > All Programs > ICP Expert II > ICP Expert II Help**.
- 2 When the ICP Expert II Help appears, click **Troubleshooting** to view instructions on how to troubleshoot.

### Spare Parts

For spare parts and consumables ordering information, refer to the Agilent Technologies website:

[www.agilent.com](http://www.agilent.com)



## **In This Book**

The manual describes the following:

- Safety Practices and Hazards
- Introduction
- Installation
- Operation
- Maintenance and Troubleshooting

© Agilent Technologies 2006, 2009-2013

Printed in Malaysia

05/13



8510230100

Issue 7



**Agilent Technologies**