



**Service Manual**



**MI-07 Integrated Engine Control  
System for 4.3L GM Engines**

**LPG Fuel Systems**

**2007 Emission-Certified Systems**

**Manual 36516**

## WARNING—DANGER OF DEATH OR PERSONAL INJURY



### WARNING—FOLLOW INSTRUCTIONS

Read this entire manual and all other publications pertaining to the work to be performed before installing, operating, or servicing this equipment. Practice all plant and safety instructions and precautions. Failure to follow instructions can cause personal injury and/or property damage.



### WARNING—OUT-OF-DATE PUBLICATION

This publication may have been revised or updated since this copy was produced. To verify that you have the latest revision, be sure to check the Woodward website:

[www.woodward.com/pubs/current.pdf](http://www.woodward.com/pubs/current.pdf)

The revision level is shown at the bottom of the front cover after the publication number. The latest version of most publications is available at:

[www.woodward.com/publications](http://www.woodward.com/publications)

If your publication is not there, please contact your customer service representative to get the latest copy.



### WARNING—OVERSPEED PROTECTION

The engine, turbine, or other type of prime mover should be equipped with an overspeed shutdown device to protect against runaway or damage to the prime mover with possible personal injury, loss of life, or property damage.

The overspeed shutdown device must be totally independent of the prime mover control system. An overtemperature or overpressure shutdown device may also be needed for safety, as appropriate.



### WARNING—PROPER USE

Any unauthorized modifications to or use of this equipment outside its specified mechanical, electrical, or other operating limits may cause personal injury and/or property damage, including damage to the equipment. Any such unauthorized modifications: (i) constitute "misuse" and/or "negligence" within the meaning of the product warranty thereby excluding warranty coverage for any resulting damage, and (ii) invalidate product certifications or listings.

## CAUTION—POSSIBLE DAMAGE TO EQUIPMENT OR PROPERTY



### CAUTION—BATTERY CHARGING

To prevent damage to a control system that uses an alternator or battery-charging device, make sure the charging device is turned off before disconnecting the battery from the system.



### CAUTION—ELECTROSTATIC DISCHARGE

Electronic controls contain static-sensitive parts. Observe the following precautions to prevent damage to these parts.

- Discharge body static before handling the control (with power to the control turned off, contact a grounded surface and maintain contact while handling the control).
- Avoid all plastic, vinyl, and Styrofoam (except antistatic versions) around printed circuit boards.
- Do not touch the components or conductors on a printed circuit board with your hands or with conductive devices.

## IMPORTANT DEFINITIONS

- A **WARNING** indicates a potentially hazardous situation which, if not avoided, could result in death or serious injury.
- A **CAUTION** indicates a potentially hazardous situation which, if not avoided, could result in damage to equipment or property.
- A **NOTE** provides other helpful information that does not fall under the warning or caution categories.

Revisions—Text changes are indicated by a black line alongside the text.

Woodward Governor Company reserves the right to update any portion of this publication at any time. Information provided by Woodward Governor Company is believed to be correct and reliable. However, no responsibility is assumed by Woodward Governor Company unless otherwise expressly undertaken.

# Contents

|   |           |
|---|-----------|
| <b>REGULATORY COMPLIANCE.....</b>               | <b>V</b>  |
| EPA / CARB Emissions Certification.....         | v         |
| North American Compliance .....                 | v         |
| <b>SPECIAL CONDITIONS FOR SAFE USE .....</b>    | <b>VI</b> |
| Electromagnetic Compatibility (EMC).....        | vi        |
| Electrostatic Discharge Awareness.....          | vii       |
| <b>CHAPTER 1. LPG SYSTEM OVERVIEW .....</b>     | <b>3</b>  |
| MI-07 General Description .....                 | 3         |
| MI-07 System Components .....                   | 5         |
| Key Components .....                            | 5         |
| MI-07 System Features .....                     | 5         |
| Customer-Supplied Components .....              | 6         |
| LPG Fuel System Operation .....                 | 7         |
| MI-07 LP Fuel Filter .....                      | 8         |
| MI-07 Fuel Lock-Off (Electric).....             | 8         |
| N-2007 Pressure Regulator/Vaporizer .....       | 9         |
| CA100 Mixer .....                               | 11        |
| Fuel Trim Valve (FTV) .....                     | 14        |
| Electronic Throttle System .....                | 16        |
| MI-07 Electronic Throttle .....                 | 16        |
| Ignition System.....                            | 18        |
| Exhaust System.....                             | 19        |
| Catalytic Muffler .....                         | 20        |
| SECM .....                                      | 21        |
| Fuel Management.....                            | 21        |
| Speed Management .....                          | 22        |
| Ignition Management .....                       | 25        |
| SECM Electrical Mounting Recommendations.....   | 25        |
| SECM / Sensors .....                            | 26        |
| Analog Inputs.....                              | 26        |
| Frequency/Position Inputs.....                  | 26        |
| Digital Inputs .....                            | 26        |
| Outputs .....                                   | 27        |
| SECM-48 Wiring Diagram .....                    | 28        |
| <b>CHAPTER 2. SPECIFICATIONS .....</b>          | <b>30</b> |
| LP Fuel System Requirements.....                | 30        |
| Environmental / Electrical Specifications ..... | 30        |
| N-2007 Pressure Regulator Specifications .....  | 31        |
| CA100 Mixer Specifications .....                | 32        |
| Electronic Throttle System Specifications ..... | 32        |
| SECM Specifications .....                       | 33        |
| Fuel Trim Valve (FTV) Specifications.....       | 33        |
| Ignition System Specifications.....             | 33        |
| System Control Performance Specifications.....  | 34        |
| Power /Torque .....                             | 34        |
| Exhaust Emissions .....                         | 34        |
| Drivability / Transient Response.....           | 34        |
| Low Idle Speed.....                             | 34        |
| Maximum Speed / High Idle .....                 | 34        |
| <b>CHAPTER 3. RECOMMENDED MAINTENANCE .....</b> | <b>35</b> |
| Maintenance Tests & Inspections .....           | 35        |
| Test Fuel System for Leaks.....                 | 35        |

|  |           |
|--|-----------|
| Inspect Engine for Fluid Leaks .....   | 35        |
| Inspect Vacuum Lines and Fittings .....  | 35        |
| Inspect Electrical System .....  | 35        |
| Inspect Foot Pedal Operation .....   | 36        |
| Check Coolant Level .....  | 36        |
| Inspect Coolant Hoses .....  | 36        |
| Inspect Battery System .....   | 36        |
| Inspect Ignition System .....  | 36        |
| Replace Spark Plugs .....  | 36        |
| Replace LP Fuel Filter Element .....   | 37        |
| Testing Fuel Lock-off Operation .....  | 38        |
| Pressure Regulator/Converter Inspection .....  | 38        |
| Fuel Trim Valve Inspection (FTV) .....   | 38        |
| Inspect Air/Fuel Valve Mixer Assembly .....  | 39        |
| Inspect for Intake Leaks .....   | 39        |
| Inspect Throttle Assembly .....  | 39        |
| Checking the TMAP Sensor .....   | 39        |
| Inspect Engine for Exhaust Leaks .....   | 39        |
| Maintenance Schedule .....   | 40        |
| <b>CHAPTER 4. INSTALLATION PROCEDURES.....</b>   | <b>42</b> |
| Hose Connections .....   | 43        |
| Removal and Installation of N-2007 LP Regulator/Converter .....  | 44        |
| Removal and Installation of CA100 Mixer .....  | 45        |
| <b>CHAPTER 5. TESTS AND ADJUSTMENTS.....</b>   | <b>48</b> |
| N-2007 Regulator Service Testing .....   | 48        |
| Break-Off Test .....   | 48        |
| Pressure Test .....  | 49        |
| AVV (Air Valve Vacuum) Testing .....   | 51        |
| Ignition Timing Adjustment .....   | 51        |
| Connection of MI-07 Service Tool .....   | 52        |
| Idle Mixture Adjustment .....  | 53        |
| <b>CHAPTER 6. BASIC TROUBLESHOOTING .....</b>  | <b>57</b> |
| Preliminary Checks .....   | 57        |
| Basic Troubleshooting .....  | 58        |
| Intermittents .....  | 58        |
| Surges and/or Stumbles .....   | 59        |
| Engine Cranking but Will Not Start / Difficult to Start .....  | 60        |
| Lack of Power, Slow to Respond / Poor High Speed Performance /<br>Hesitation During Acceleration ..... | 62        |
| Detonation / Spark Knock .....   | 64        |
| Backfire .....   | 65        |
| Dieseling, Run-on .....  | 65        |
| Rough, Unstable, Incorrect Idle, or Stalling .....   | 67        |
| Cuts Out, Misses .....   | 69        |
| Poor Fuel Economy / Excessive Fuel Consumption LPG Exhaust Smell .....                                 | 70        |
| High Idle Speed .....  | 71        |
| Excessive Exhaust Emissions or Odors .....   | 72        |
| Diagnostic Aids for Rich / Lean Operation .....  | 73        |
| Chart T-1 Restricted Exhaust System Check .....  | 74        |
| <b>CHAPTER 7. ADVANCED DIAGNOSTICS .....</b>   | <b>75</b> |
| Reading Diagnostic Fault Codes .....   | 75        |
| Displaying Fault Codes (DFC) from SECM Memory .....  | 75        |
| Clearing Fault (DFC) Codes .....   | 75        |
| Fault Action Descriptions .....  | 77        |
| Fault List Definitions .....   | 78        |
| Table 1. Fault List Definitions .....  | 78        |
| Table 2. Diagnostic Fault Codes (Flash Codes) .....  | 85        |

**CHAPTER 9. PARTS DESCRIPTION ..... 100**  
LP Fuel System Components for 4.3L GM Engines ..... 100  
Fuel Trim Valve ..... 100  
Ignition Coils ..... 100  
CA100 Mixer ..... 101  
N-2007 Regulator ..... 103

**APPENDIX ..... 105**  
LPG & LPG Fuel Tanks ..... 105  
    LPG Fuel Tanks ..... 107  
    Installing LPG Fuel Tanks ..... 107  
    LPG Fuel Tank Components ..... 108  
    Fuel Gauge ..... 108  
    Pressure Relief Valve ..... 109  
    Service Valve ..... 109  
    Quick Disconnect Coupling ..... 111  
    Filler Valve ..... 111  
Abbreviations ..... 113

## List of Figures

|  |     |
|--|-----|
| Figure 1. MI-07 System for 4.3L GM LP Engines .....                  | 3   |
| Figure 2. MI-07 Closed Loop LP Fuel System .....                     | 4   |
| Figure 3. Inline LP Fuel Filter .....                                | 8   |
| Figure 4. Electric Fuel Lock Assembly .....                          | 8   |
| Figure 5. N-2007 Regulator .....                                     | 9   |
| Figure 6. Parts View of N-2007 Regulator .....                       | 10  |
| Figure 7. CA100 Mixer.....   | 11  |
| Figure 8. CA100 Mixer Attached to Throttle Body.....                 | 11  |
| Figure 9. Parts View of CA100 Mixer .....                            | 12  |
| Figure 10. Bottom View of Air Valve Assembly.....                    | 13  |
| Figure 11. CA100 Mixer Installed with Electronic Throttle .....      | 13  |
| Figure 12. Idle Mixture Adjustment Screw .....                       | 14  |
| Figure 13. Fuel Trim Valves Connected to MI-07 System .....          | 15  |
| Figure 14. Bosch Electronic Throttle Body.....                       | 16  |
| Figure 15. Throttle Body Assembly Exploded View .....                | 17  |
| Figure 16. HEGO (O2) Sensor .....                                    | 20  |
| Figure 17. Foot Pedal.....   | 22  |
| Figure 18. Throttle Position Sensor (TPS) on DV-E5 Throttle .....    | 22  |
| Figure 19. Peak Torque and Power Available with MI-07 System.....    | 23  |
| Figure 20. Drive-By-Wire Signal Flow Process.....                    | 24  |
| Figure 21. SECM Wiring Diagram for LP Certified System.....          | 29  |
| Figure 22. MI-07 System Installed on GM 4.3L Engine .....            | 38  |
| Figure 23. Hose Connections for 4.3L Engine .....                    | 43  |
| Figure 24. N-2007 Regulator Installed on Engine .....                | 44  |
| Figure 25. CA100 Mixer Installed on Engine.....                      | 46  |
| Figure 26. O-Ring and Spacer Within Mixer Adapter Assembly.....      | 46  |
| Figure 27. Throttle Adapter Mount Screws .....                       | 46  |
| Figure 28. Secondary Stage Test Connection .....                     | 49  |
| Figure 29. Primary Stage Test Connection .....                       | 49  |
| Figure 30. Magnehelic Gauge Connection to Hose Barb .....            | 50  |
| Figure 31. Magnehelic Gauge Connection.....                          | 51  |
| Figure 32. KVaser Communication Adapter.....                         | 52  |
| Figure 33. Crypt Token Installed on Laptop .....                     | 52  |
| Figure 34. Opening the Service Tool Display.....                     | 52  |
| Figure 35. FTV Duty Cycle Percentage Displayed on Service Tool ..... | 54  |
| Figure 36. Installing Tamper Proof Cap .....                         | 55  |
| Figure 37. CA100 Mixer Exploded View .....                           | 102 |
| Figure 38. N-2007 Regulator Exploded View.....                       | 104 |
| Figure A1. LPG Tank Pressure vs Temperature.....                     | 106 |
| Figure A2. Portable Universal Cylinder .....                         | 107 |
| Figure A3. LPG Fuel Tank Components .....                            | 108 |
| Figure A4. Service Valve .....                                       | 109 |
| Figure A5. Quick Disconnect Coupling .....                           | 111 |
| Figure A6. Liquid Filler Valve .....                                 | 111 |

# Regulatory Compliance

## EPA / CARB Emissions Certification

When properly applied and calibrated, Woodward's MI-07 control system is capable of meeting Environmental Protection Agency (EPA) 2007 LSI emission standards (40 CFR Part 1048.101) when operating properly with an approved three-way catalyst. The emission standards, including appropriate deterioration factors over the useful life of the system, are as follows:

HC+NOx: 2.0 g/hp-hr [2.7 g/kW-hr]

CO: 3.3 g/hp-hr [4.4 g/kW-hr]

Evaporative emissions comply with 40 CFR Part 1048.105. These standards apply only to volatile liquid fuels such as gasoline. Note that the engine crankcase must be closed.

As defined in applicable regulations, the engine control system is designed to maintain emissions compliance for seven (7) years or 5000 hours, whichever occurs first, provided appropriate maintenance is performed as defined in the service manual for the system. Maintenance intervals shall be defined and approved by the regulating body. Component warranty shall comply with regulatory requirements (40 CFR Part 1048.120) for all emission related components. Warranty for non-critical emissions components will be as defined in the individual purchase agreement.

## North American Compliance

The N-2007 regulator is UL listed per Category ITPV LP-Gas Accessories, Automotive Type.

The N-2007 regulator and CA100 mixer have tamper-resistant features approved by the California Air Resources Board (CARB).

## Special Conditions for Safe Use

Field wiring must be suitable for at least 248°F (120°C).

SECM-48 inputs are classified as permanently connected IEC measurement Category I. To avoid the danger of electric shock, do not use inputs to make measurements within measurement categories II, III, or IV. See Woodward publication 26377, SECM-48 Manual, Chapter 2 for additional information on transient over-voltage input ratings.

SECM-48 input power must be supplied from a power supply/battery charger certified to IEC standard with a SELV (Safety Extra Low Voltage) classified output. Input power should be properly fused according to the wiring diagram in Woodward publication 26377, SECM-48 Manual.

SECM-48 inputs and outputs may only be connected to other circuits certified as SELV (Safety Extra Low Voltage).

The IP-56 Ingress Protection rating of the control depends on the use of proper mating connectors. See Woodward publication 26377, SECM-48 Manual, Chapter 2: Installation—Wiring Connections, Table 2-1 for information on the proper mating connectors for use with this control.



### **WARNING—EXPLOSION HAZARD**

**Do not connect or disconnect while circuit is live unless area is known to be non-hazardous.**

**Substitution of components may impair suitability for Class I, Division 2, or Zone 2 applications.**

## Electromagnetic Compatibility (EMC)

All MI-07 active electronic components manufactured by the Woodward Governor Company have been developed and individually tested for electromagnetic compatibility using standardized industry methods under laboratory test conditions. Actual EMC performance may be adversely affected by the wiring harness design, wire routing, the surrounding structure, other EMC generating components, and other factors that are beyond the control of the Woodward Governor Company. It is the responsibility of the vehicle and/or application manufacturer to confirm that the overall system's EMC performance is in compliance with all standards that they wish to apply for their particular use.



## Electrostatic Discharge Awareness

All electronic equipment is static-sensitive, some components more than others. To protect these components from static damage, you must take special precautions to minimize or eliminate electrostatic discharges.

Follow these precautions when working with or near the control.

1. Before doing maintenance on the electronic control, discharge the static electricity on your body to ground by touching and holding a grounded metal object (pipes, cabinets, equipment, etc.).
2. Avoid the build-up of static electricity on your body by not wearing clothing made of synthetic materials. Wear cotton or cotton-blend materials as much as possible because these do not store static electric charges as much as synthetics.
3. Keep plastic, vinyl, and Styrofoam materials (such as plastic or Styrofoam cups, cup holders, cigarette packages, cellophane wrappers, vinyl books or folders, plastic bottles, and plastic ash trays) away from the control, the modules, and the work area as much as possible.



### **CAUTION—ELECTROSTATIC DISCHARGE**

To prevent damage to electronic components caused by improper handling, read and observe the precautions in Woodward manual 82715, *Guide for Handling and Protection of Electronic Controls, Printed Circuit Boards, and Modules*.



# Chapter 1. LPG System Overview

## MI-07 General Description

Woodward's emission-certified MI-07 control system provides a complete, fully integrated engine management system that meets or exceeds 2007 emission standards for Large Spark Ignited (LSI) engines established by the California Air Resources Board (CARB) and the Environmental Protection Agency (EPA).

The control system is applicable to naturally aspirated engines ranging in size from 1.5L to 8.1L (25 HP to 170 HP) with up to 8 cylinders running on LPG in mobile industrial applications.

It provides accurate, reliable, and durable control of fuel, spark, and air over the service life of the engine in the extreme operating environment found in heavy-duty, under hood, on-engine electronic controls.

MI-07 is a closed loop system utilizing a catalytic muffler to reduce the emission level in the exhaust gas. In order to obtain maximum effect from the catalyst, an accurate control of the air fuel ratio is required. A small engine control module (SECM) uses two heated exhaust gas oxygen sensors (HEGO) in the exhaust system to monitor exhaust gas content. One HEGO is installed in front of the catalytic muffler and one is installed after the catalytic muffler.

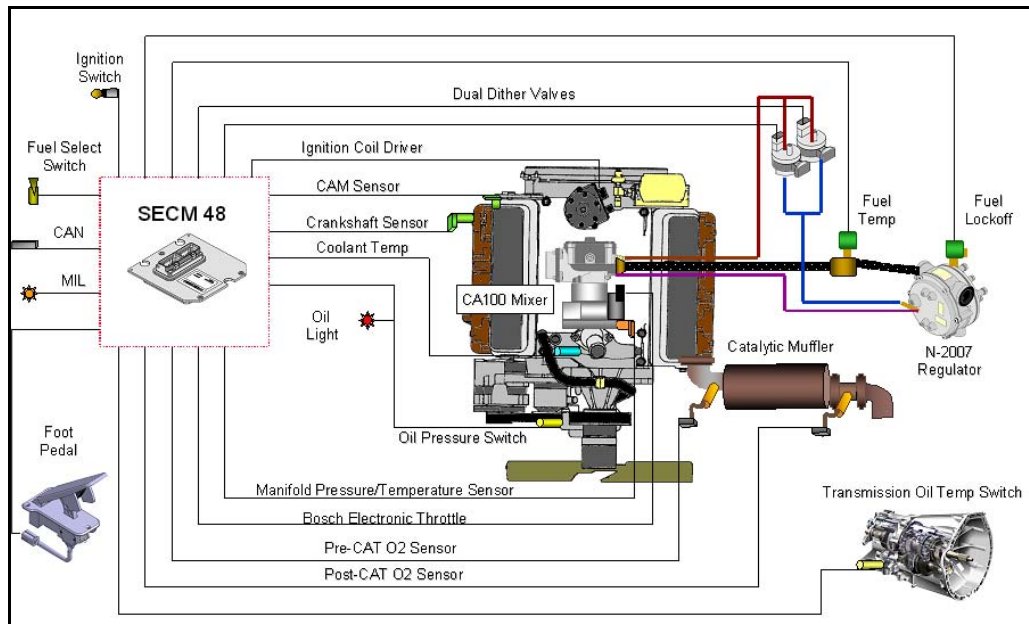

Figure 1. MI-07 System for 4.3L GM LP Engines

The SECM makes any necessary corrections to the air fuel ratio by controlling the inlet fuel pressure to the air/fuel mixer by modulating the dual fuel trim valves (FTV) connected to the regulator. Reducing the fuel pressure leans the air/fuel mixture and increasing the fuel pressure enriches the air/fuel mixture. To calculate any necessary corrections to the air fuel ratio, the SECM uses a number of different sensors to gain information about the engine's performance. Engine speed is monitored by the SECM through a variable reluctance (VR) or Hall Effect sensor. Intake manifold air temperature and absolute pressure are monitored with a TMAP sensor. MI-07 is a

drive-by-wire (DBW) system connecting the accelerator pedal to the electronic throttle through the electrical harness; mechanical cables are not used. A throttle position sensor (TPS) monitors throttle position in relation to the accelerator pedal position sensor (APP) command. Even engine coolant temperature and adequate oil pressure are monitored by the SECM. The SECM controller has full adaptive learning capabilities, allowing it to adapt control function as operating conditions change. Factors such as ambient temperature, fuel variations, ignition component wear, clogged air filter, and other operating variables are compensated.

### MI-07 Closed Loop LP Fuel System

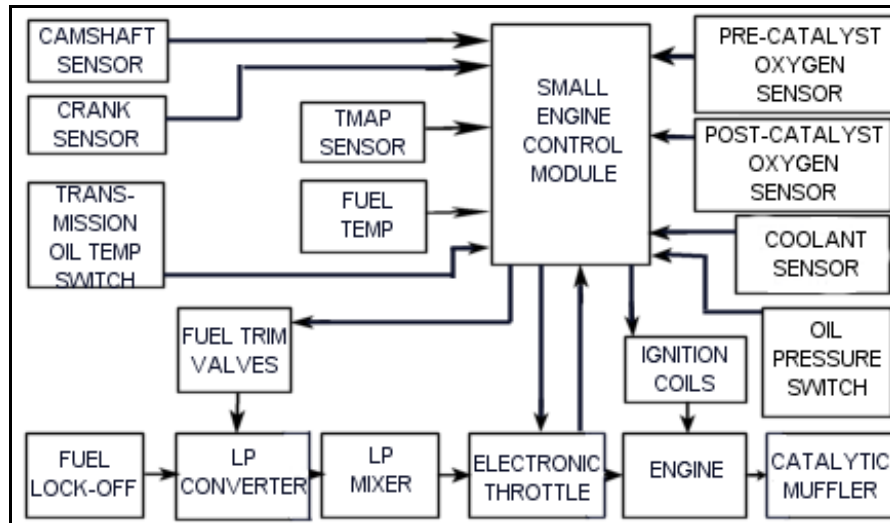

Figure 2. MI-07 Closed Loop LP Fuel System

## MI-07 System Components

The MI-07 control system provides electronic control to the following subsystems on mobile industrial engines:

- Fuel delivery system
- Spark-ignition control system
- Air throttle
- Sensors/Switches/Speed inputs

### Key Components

The MI-07 system functions primarily on engine components that affect engine emissions and performance. These key components include the following:

- Engine/Combustion chamber design
- Intake/Exhaust valve configuration, timing and lift
- Intake/Exhaust manifold design
- Catalytic converter and exhaust system
- Throttle body
- Air intake and air filter
- Gaseous fuel mixer †
- Gaseous fuel pressure regulator †
- Fuel trim valves
- Fuel trim orifices
- Small engine control module (SECM), firmware and calibration †
- Fuel system sensors and actuators
- Ignition system including spark plugs, cables, coils and drivers

(†) Components of MI-07 system manufactured by Woodward

## MI-07 System Features

The MI-07 system uses an advanced speed-density control strategy for fuel, spark, and air throttle control. Key features include the following.

- Closed-loop fuel
- Speed-load spark control with tables for dwell, timing, and fuel type
- Speed-load throttle control with table for maximum TPS limiting
- Closed-loop fuel control with two oxygen sensors (one installed pre catalyst and one installed post catalyst). The pre-catalyst oxygen sensor includes adaptive learn to compensate for fuel or component drift. The post-catalyst oxygen sensor includes adaptive learn to compensate the pre-catalyst oxygen sensor setting for pre-catalyst oxygen sensor drift and catalyst aging. The pre-catalyst oxygen sensor function includes parameters for transport delay, O<sub>2</sub> set point, excursion rich/lean, jump back rich/lean, and perturbation.
- LPG fuel temperature compensation
- Min/max governing
- All-speed isochronous governing
- Fixed-speed isochronous governing with three switch-selectable speeds
- Fuel enrichment and spark timing modifiers for temperature and fuel type

- Transient fuel enrichment based on rate of change of TPS
- Input sensor selection and calibration
- Auxiliary device control for fuel pump, fuel lock-off solenoid, tachometer, MIL, interlocks, vehicle speed limiting, etc.
- CANBus data transfer for speed, torque, etc.

### Other System Features Include:

#### Tamper-Resistance

Special tools, equipment, knowledge, and authorization are required to effect any changes to the MI-07 system, thereby preventing unauthorized personnel from making adjustments that will affect performance or emissions.

#### Diagnostics

MI-07 is capable of monitoring and diagnosing problems and faults within the system. These include all sensor input hardware, control output hardware, and control functions such as closed-loop fuel control limits and adaptive learn limits. Upon detecting a fault condition, the system notifies the operator by illuminating the MIL and activating the appropriate fault action. The action required by each fault shall be programmable by the OEM customer at the time the engine is calibrated.

Diagnostic information can be communicated through both the service tool interface and the MIL lamp. With the MIL lamp, it is possible to generate a string of flashing codes that correspond to the fault type. These diagnostics are generated only when the engine is not running and the operator initiates a diagnostic request sequence such as repeated actuations of the pedal within a short period of time following reset.

#### Limp Home Mode

The system is capable of "limp-home" mode in the event of particular faults or failures in the system. In limp-home mode the engine speed is approximately 1000 rpm at no load. A variety of fault conditions can initiate limp-home mode. These fault conditions and resulting actions are determined during calibration and are OEM customer specific.

#### Service Tool

A scan tool/monitoring device is available to monitor system operation and assist in diagnosis of system faults. This device monitors all sensor inputs, control outputs, and diagnostic functions in sufficient detail through a single access point to the SECM to allow a qualified service technician to maintain the system. This Mototune software (licensed by Mototron Communication) is secure and requires a crypt-token USB device to allow access to information.

## Customer-Supplied Components

MI-07 requires additional components to operate that are not included with the system. These include the wire harness, mixer-to-throttle adapter, air horn adapter, mounting brackets, non-critical fittings, and hoses. These items are application specific and are the responsibility of the packager, manufacturer of record (MOR), or original equipment manufacturer (OEM). Woodward will provide assistance as needed to ensure proper fitting to the MI-07 system components.



#### NOTE

**It is the responsibility of the customer to consult with Woodward regarding the selection or specification of any components that impact emissions, performance, or durability.**

## LPG Fuel System Operation

The principles outlined below describe the operation of MI-07 on an LPG fuel system.

An LPG fuel system consists of the following components:

- Fuel filter (supplied by customer)
- Electric fuel lock-off solenoid valve
- Fuel pressure regulator/vaporizer
- Two orificed fuel trim valves
- Gas/Air mixer with fixed orifice for trim system and fuel temperature sensor
- Miscellaneous customer-supplied hoses and fittings

Fuel is stored in the customer-supplied LPG tank in saturated liquid phase and enters the fuel system from the tank as a liquid and at tank pressure. Fuel passes through a high-pressure fuel filter and lock-off solenoid, and is then vaporized and regulated down to the appropriate pressure to supply the mixer. The regulator controls the fuel pressure to the gas/air mixer.

### Dual Dither Valve

The key to meeting emissions requirements when operating in LPG is the dual dither valve hardware in the fuel system. Similar to the Woodward MI-04 system, the dual dither system modulates the fuel pressure regulator outlet pressure by providing an offset to the regulator secondary stage reference pressure. By adding a second dither valve, or fuel trim valve (FTV), to the MI-07 system, smoother, more accurate control of supply pressure is achieved, resulting in better control of air fuel ratio and emissions. This smoother control also minimizes wear on fuel system components such as the regulator diaphragm and lever by significantly reducing the pressure pulsations observed with a single FTV.

### Regulator Pressure Offset

Regulator pressure offset is achieved through the use of a fixed orifice and a variable orifice in series. The inlet to the fixed orifice is connected to the mixer inlet pressure (roughly equal to ambient pressure). The outlet of the fixed orifice is connected to both the pressure regulator reference port and the inlet to the two FTVs (the variable orifice) that act in parallel. The outlets of the FTVs are connected to the mixer outlet, referred to as Air Valve Vacuum (AVV). Thus, by modulating the FTVs, the pressure regulator reference pressure can be varied between mixer inlet pressure and AVV. For a given change in the pressure regulator reference pressure, the pressure regulator outlet pressure changes by the same amount and in the same direction. The end result is that a change in FTV modulation changes the outlet pressure of the regulator/fuel inlet pressure of the mixer, and thus the AFR. A major benefit of this trim system results from the use of mixer inlet pressure and AVV as the reference pressure extremes. The pressure differential across the mixer fuel valve is related to these same two pressures, and thus so is fuel flow. Given this arrangement, the bias pressure delta scales with the fuel cone delta pressure. The result is that the trim system control authority and resolution on AFR stays relatively constant for the entire speed and load range of the engine.

### SECM

The Small Engine Control Module (SECM) controls the LPG lock-off solenoid valve and the FTVs. The lock-off solenoid is energized when fueling with LPG and the engine is turning. FTV modulation frequency will be varied as a function of rpm by the

SECM in order to avoid resonance phenomena in the fuel system. FTV commands will be altered by the SECM in order to maintain a stoichiometric air-fuel ratio. Commands are based primarily on feedback from the exhaust gas oxygen sensor, with an offset for fuel temperature.

### MI-07 LP Fuel Filter

After exiting the fuel tank, liquid propane passes through a serviceable inline fuel filter to the electric fuel lock off. **Figure 3** shows a typical inline type LP fuel filter manufactured by Century. The primary function of the fuel filter is to remove particles and sediments that have found their way into the tank. The LP fuel filter will *not* remove heavy end solids and paraffins that build up in LPG fuel systems as a result of vaporization.



**Figure 3. Inline LP Fuel Filter**

### MI-07 Fuel Lock-Off (Electric)

The fuel lock-off is a safety shutoff valve, normally held closed by spring pressure, which is operated by an electric solenoid and prevents fuel flow to the regulator/ converter when the engine is not in operation. This is the first of three safety locks in the MI-07 system.

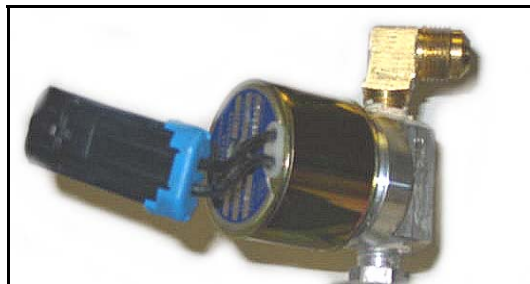

**Figure 4. Electric Fuel Lock Assembly**

In the MI-07 design, power is supplied to the fuel lock-off via the main power relay with the SECM controlling the lock-off ground (earth) connection. The lock-off remains in a normally closed (NC) position until the key switch is activated. This supplies power to the lock-off and the SECM, but will not open the lock-off via the main power relay until the SECM provides the lock-off ground connection. This design gives the SECM full control of the lock-off while providing additional safety by closing the fuel lock-off in the unlikely event of a power failure, wiring failure or module failure.

When the liquid service valve in the fuel container is opened, liquid propane flows through the LP filter and through the service line to the fuel lock-off. Liquid propane enters the lock-off through the 1/4" NPT liquid inlet port and stops with the lock-off in the normally closed position. When the engine is cranked over the main power relay applies power to the lock-off and the SECM provides the lock-off ground causing current to flow through the windings of the solenoid creating a magnetic field. The strength of this magnetic field is sufficient to lift the lock-off valve off of its seat against spring pressure. When the valve is open liquid propane, at tank pressure, flows through the lock-off outlet to the pressure regulator/converter. A stall safety shutoff



feature is built into the SECM to close the lock-off in case of a stall condition. The SECM monitors three engine states: *Crank*, when the crankshaft position sensor detects any engine revolutions; *Stall*, when the key is in the ON position but the crankshaft position sensor detects no engine revolutions; and the *Run* state, when the engine reaches pre-idle rpm. When an operator turns on the key switch the lock-off is opened, but if the operator fails to crank the engine the SECM will close the lock-off after 5 seconds.

### N-2007 Pressure Regulator/Vaporizer

The pressure regulator/vaporizer receives liquid LPG from the fuel storage tank, drops the pressure, changes the LPG phase from liquid to vapor, and provides vapor phase LPG at a regulated outlet pressure to the mixer. To offset the refrigeration effect of the vaporization process, the regulator will be supplied with engine coolant flow sufficient to offset the latent heat of vaporization of the LPG. A thermostat provided in the coolant supply line to maintain regulator outlet coolant temperature at or below 140°F (60°C) will minimize the deposit of fuel contaminants and heavy ends in the regulator and assure a more controlled vaporization process with reduced pressure pulsations.

A higher flow pressure regulator is required on larger engines.



Figure 5. N-2007 Regulator

The regulator is normally closed, requiring a vacuum signal (negative pressure) to allow fuel to flow. This is the second of three safety locks in the MI-07 system. If the engine stops, vacuum signal stops and fuel flow will automatically stop when both the secondary (2<sup>nd</sup> stage) valve and the primary (1<sup>st</sup> stage) valve closes. Unlike most other regulator/converters, the N-2007 primary valve closes *with* fuel pressure rather than against pressure, extending primary seat life and adding additional safety.

Liquid propane must be converted into a gaseous form in order to be used as a fuel for the engine. When the regulator receives the desired vacuum signal it allows propane to flow to the mixer. As the propane flows through the regulator the pressure is reduced in two stages from tank pressure to slightly less than atmospheric pressure. As the pressure of the propane is reduced, the liquid propane vaporizes and refrigeration occurs inside the regulator due to the vaporization of liquid propane. To replace heat lost to vaporization, engine coolant is supplied by the engine driven water pump and pumped through the regulator. Heat provided by this coolant is transferred through to the fuel vaporization chamber.

### N-2007 Operation

(Refer to **Figure 6**.)

Liquid propane, at tank pressure, enters the N-2007 through the fuel inlet port (1). Propane liquid then flows through the primary valve (2). The primary valve located at the inlet of the expansion chamber (3), is controlled by the primary diaphragm (4), which reacts to vapor pressure inside the expansion chamber. Two springs are used to apply force on the primary diaphragm in the primary diaphragm chamber (5), keeping the primary valve open when no fuel pressure is present.

A small port connects the expansion chamber to the primary diaphragm chamber. At the outlet of the expansion chamber is the secondary valve (6). The secondary valve

is held closed by the secondary spring on the secondary valve lever (7). The secondary diaphragm controls the secondary lever. When the pressure in the expansion chamber reaches 1.5 psig (10.342 kPa) it causes a pressure/force imbalance across the primary diaphragm (8). This force is greater than the primary diaphragm spring pressure and will cause the diaphragm to close the primary valve.

Since the fuel pressure has been reduced from tank pressure to 1.5 psig (10.342 kPa) the liquid propane vaporizes. As the propane vaporizes it takes on heat from the expansion chamber. This heat is replaced by engine coolant, which is pumped through the coolant passage of the regulator. At this point vapor propane will not flow past the expansion chamber of the regulator until the secondary valve is opened. To open the secondary valve, a negative pressure signal must be received from the air/fuel mixer. When the engine is cranking or running a negative pressure signal (vacuum) travels through the vapor fuel outlet connection of the regulator, which is the regulator secondary chamber, and the vapor fuel inlet of the mixer. The negative pressure in the secondary chamber causes a pressure/force imbalance on the secondary diaphragm, which overcomes the secondary spring force, opening the secondary valve and allowing vapor propane to flow out of the expansion chamber, through the secondary chamber to the mixer.

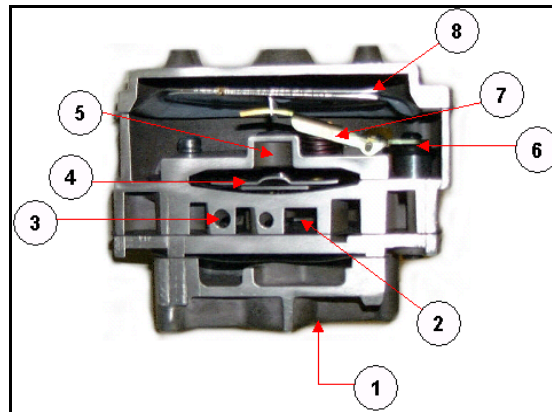

**Figure 6. Parts View of N-2007 Regulator**

Because vapor propane has now left the expansion chamber, the pressure in the chamber will drop, causing the primary diaphragm spring force to re-open the primary valve allowing liquid propane to enter the regulator, and the entire process starts again. This creates a balanced condition between the primary and secondary chambers allowing for a constant flow of fuel to the mixer as long as the demand from the engine is present. The fuel flow is maintained at a constant output pressure, due to the calibrated secondary spring. The amount of fuel flowing will vary depending on how far the secondary valve opens in response to the negative pressure signal generated by the air/fuel mixer. The strength of that negative pressure signal developed by the mixer is directly related to the amount of air flowing through the mixer into the engine. With this process, the larger the quantity of air flowing into the engine, the larger the amount of fuel flowing to the mixer.

## CA100 Mixer

The mixer is installed above the throttle body and meters gaseous fuel into the airstream at a rate that is proportional to the volumetric flow rate of air. The ratio between volumetric airflow and volumetric fuel flow is controlled by the shaping of the mixer fuel cone and biased by the controllable fuel supply pressure delivered by the pressure regulator. Fuel flow must be metered accurately over the full range of airflows. Pressure drop across the mixer air valve must be minimized to assure maximum power output from the engine.

The mixer fuel inlet is fitted with a thermistor-type temperature sensor. This permits the SECM to correct fuel pressure to compensate for variations in fuel temperature. Left uncorrected, fuel temperature variations can cause significant variations in air fuel ratio.

A higher flow mixer is required on larger engines. A lower flow mixer is required on smaller engines.



Figure 7. CA100 Mixer

## CA100 Mixer Operation

Vapor propane fuel is supplied to the CA100 mixer by the N-2007 pressure regulator/converter. The mixer uses a diaphragm type air valve assembly to operate a gas-metering valve inside the mixer. The gas-metering valve is normally closed, requiring a negative pressure (vacuum) signal from a cranking or running engine to open. This is the third of the three safety locks in the MI-07 system. If the engine stops or is turned off, the air valve assembly closes the gas-metering valve, stopping fuel flow past the mixer. The gas-metering valve controls the amount of fuel to be mixed with the incoming air at the proper ratio. The air/fuel mixture then travels past the throttle, through the intake manifold and into the engine cylinders where it is compressed, ignited and burned.

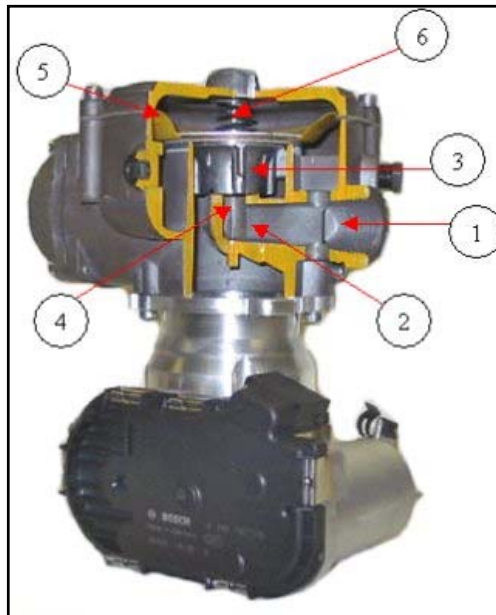

Figure 8. CA100 Mixer Attached to Throttle Body

(Refer to **Figure 9**.)

The air/fuel mixer is mounted in the intake air stream between the air cleaner and the throttle. The design of the main body incorporates a cylindrical bore or mixer bore, fuel inlet (1) and a gas discharge jet (2). In the center of the main body is the air valve assembly, which is made up of the air valve (3), the gas-metering valve (4), and air valve diaphragm (5) and air valve spring (6). The gas-metering valve is permanently mounted to the air valve diaphragm assembly with a face seal mounted between the two parts.

When the engine is not running this face seal creates a barrier against the gas discharge jet, preventing fuel flow with the aid (downward force) of the air valve spring. When the engine is cranked over it begins to draw in air, creating a negative pressure signal. This negative pressure signal is transmitted through four vacuum ports in the air valve.



**Figure 9. Parts View of CA100 Mixer**

A pressure/force imbalance begins to build across the air valve diaphragm between the air valve vacuum (AVV) chamber (above the diaphragm) and atmospheric pressure below the diaphragm. Approximately 6 inH<sub>2</sub>O (14.945 mbar) of negative pressure is required to overcome the air valve spring force and push the air valve assembly upward off the valve seat. Approximately 24 inH<sub>2</sub>O (59.781 mbar) pulls the valve assembly to the top of its travel in the full open position.

The amount of negative pressure generated is a direct result of throttle position and the amount of air flowing through the mixer to the engine. At low engine speeds, low AVV causes the air valve diaphragm assembly to move upward a small amount, creating a small venturi. At high engine speeds, high AVV causes the air valve diaphragm assembly to move much farther creating a large venturi. The variable venturi air/fuel mixer constantly matches venturi size to engine demand.

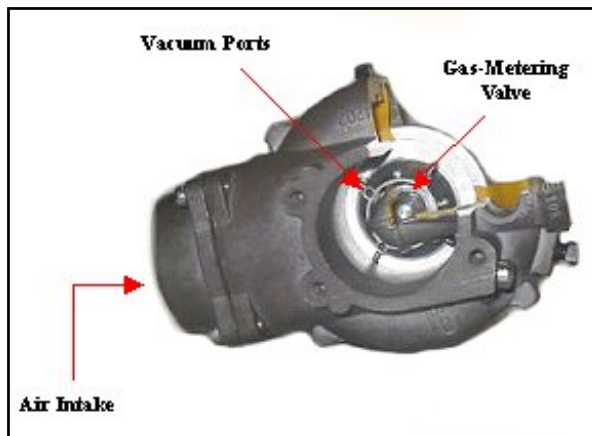

Figure 10. Bottom View of Air Valve Assembly

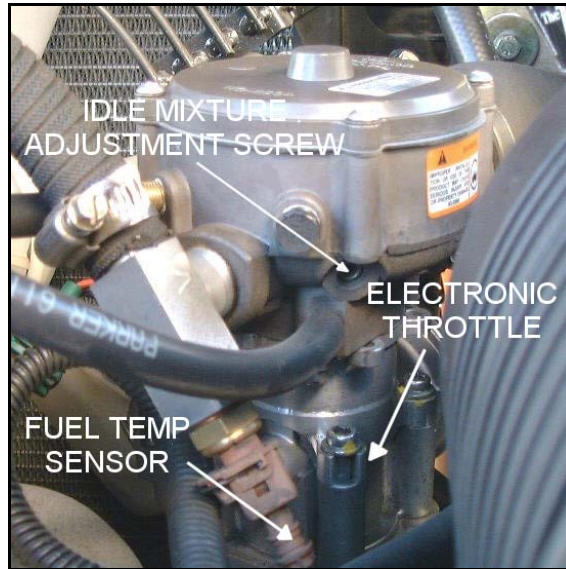

Figure 11. CA100 Mixer Installed with Electronic Throttle

A main mixture adjustment valve on the fuel inlet of the CA100 is not used in the MI-07 system, however an idle mixture adjustment is incorporated into the mixer (**Figure 12**). The idle mixture adjustment is an air bypass port, adjusting the screw all the way in, blocks off the port and enriches the idle mixture. Backing out the idle adjustment screw opens the port and leans the idle mixture. The idle mixture screw is a screw with locking threads that is factory set with a tamper resistant cap installed after adjustment. Accurate adjustment of the idle mixture can be accomplished by adjusting for a specific fuel trim valve (FTV) duty cycle with the Service Tool software or with a



voltmeter. **NOTE:** Adjustments should only be performed by trained service technicians.



**Figure 12. Idle Mixture Adjustment Screw (shown with tamper proof cap removed)**

### Fuel Trim Valve (FTV)

The Fuel Trim Valve (FTV) is a two-way electric solenoid valve and is controlled by a pulse-width modulated (PWM) signal provided by the SECM. Two FTVs are used to bias the output fuel pressure on the LPG regulator/converter (N-2007), by metering air valve vacuum (AVV) into the atmospheric side of the N-2007 secondary regulator diaphragm. An orifice balance line connected to the air inlet side of the mixer provides atmospheric reference to the N-2007 when the FTV is closed. The SECM uses feedback voltage from the O<sub>2</sub> sensor to determine the amount of bias needed to the regulator/converter.



In normal operation the N-2007 maintains fuel flow at a constant output pressure, due to the calibrated secondary spring. The amount of fuel flowing from the N-2007 will vary depending on how far the secondary diaphragm opens the secondary valve in response to the negative pressure signal generated by the air/fuel mixer. One side of the N-2007 secondary diaphragm is referenced to FTV control pressure while the other side of the diaphragm reacts to the negative pressure signal from the mixer. If the pressure on the reference side of the N-2007 secondary diaphragm is reduced, the diaphragm will close the secondary valve until a balance condition exists across the diaphragm, reducing fuel flow and leaning the air/fuel mixture.

### Branch-Tee Fitting

A branch-tee fitting is installed in the atmospheric vent port of the N-2007 with one side of the branch-tee connected to the intake side of the mixer forming the balance line and referencing atmospheric pressure. The other side of the branch-tee fitting connects to the FTV inlet (small housing side). The FTV outlet (large housing connector side) connects to the AVV port. When the FTVs are open AVV is sent to the atmospheric side of the N-2007 secondary diaphragm, which lowers the reference pressure, closing the N-2007 secondary valve and leaning the air/fuel mixture. The MI-07 system is calibrated to run rich without the FTV. By modulating (pulsing) the FTVs the SECM can control the amount of AVV applied to the N-2007 secondary diaphragm. Increasing the amount of time the FTVs remain open (modulation or duty cycle) causes the air/fuel mixture to become leaner; decreasing the modulation (duty cycle) enriches the mixture.

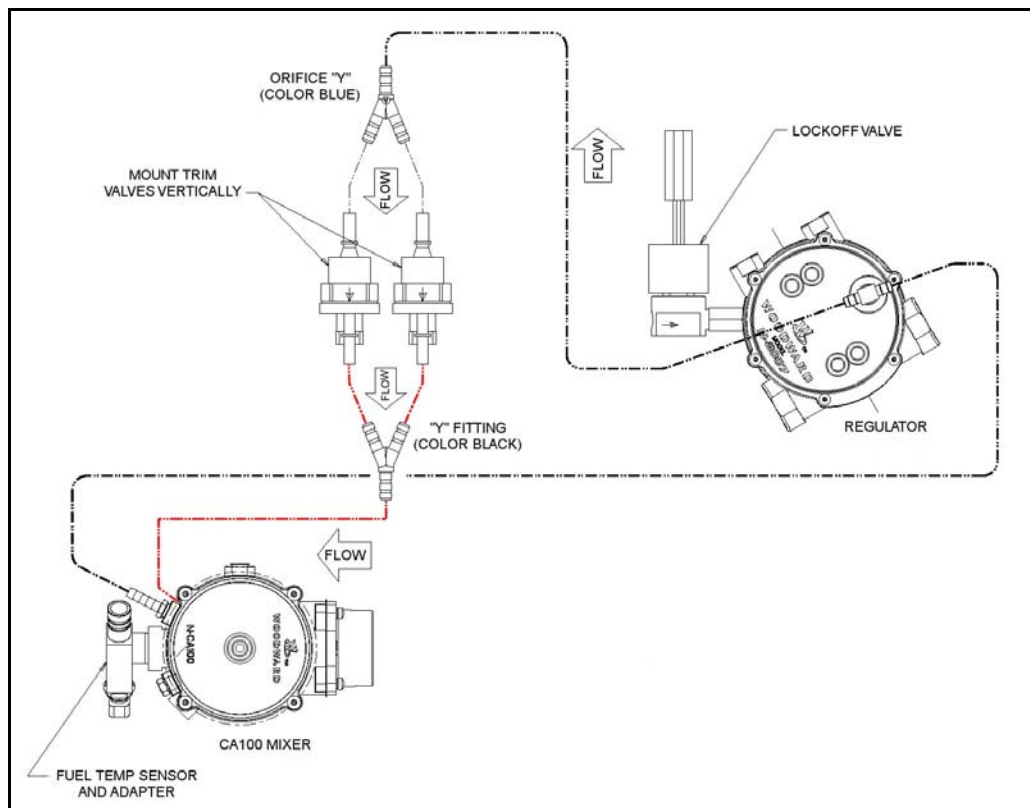

Figure 13. Fuel Trim Valves Connected to MI-07 System

## Electronic Throttle System

The electronic throttle system controls engine output (speed and torque) through electronic control of mass airflow to the engine. Any DC motor-actuated or Limited Angle Torquemotor (LAT)-actuated throttle with less than 5A peak and 2A steady state can be controlled. The TPS must be directly coupled to the throttle shaft for direct shaft position measurement.

A commonly used throttle is the Bosch DV-E5. This throttle is available in a variety of bore sizes to meet specific engine needs: 32mm, 40mm, and 54mm are readily available throttle bore sizes; other sizes are possible. The Bosch throttle is a fully validated automotive component incorporating a brushed DC motor with gear reduction, dual throttle position sensors, throttle plate, and cast aluminum housing. In the event of an electrical disconnection or other related failure, the throttle plate returns to a limp-home idle position at a no-load engine speed above curb idle speed. This provides sufficient airflow for the engine to move the vehicle on level ground. Any throttle bodies used for MI-07 meet or exceed the specification for the Bosch throttle bodies.

In terms of response, the throttle is capable of fully opening and closing in less than 50 msec. Position resolution and steady state control should be 0.25% of full travel or better.

### MI-07 Electronic Throttle

Conventional throttle systems rely on a mechanical linkage to control the throttle valve. To meet fluctuating engine demands a conventional system will typically include a throttle valve actuator designed to readjust the throttle opening in response to engine demand, together with an idle control actuator or idle air bypass valve.

In contrast, the MI-07 system uses electronic throttle control (ETC). The SECM controls the throttle valve based on engine RPM, engine load, and information received from the foot pedal. Two potentiometers on the foot pedal assembly monitor accelerator pedal travel. The electronic throttle used in the MI-07 system is a Bosch 32mm or 40mm electronic throttle body DV-E5 (**Figure 14**). The DV-E5 is a single unit assembly, which includes the throttle valve, throttle-valve actuator (DC motor) and two throttle position sensors (TPS). The SECM calculates the correct throttle valve opening that corresponds to the driver's demand, makes any adjustments needed for adaptation to the engine's current operating conditions and then generates a corresponding electrical (driver) signal to the throttle-valve actuator.



Figure 14. Bosch Electronic Throttle Body



The MI-07 uses a dual TPS design (TPS1 and TPS2). The SECM continuously checks and monitors all sensors and calculations that effect throttle valve position whenever the engine is running. If any malfunctions are encountered, the SECM's initial response is to revert to redundant sensors and calculated data. If no redundant signal is available or calculated data cannot solve the malfunction, the SECM will drive the system into one of its limp-home modes or shut the engine down, storing the appropriate fault information in the SECM.

There are multiple limp-home modes available with electronic throttle control:

1. If the throttle itself is suspected of being inoperable, the SECM will remove the power to the throttle motor. When the power is removed, the throttle blade returns to its "default" position, approximately 7% open.
2. If the SECM can still control the throttle but some other part of the system is suspected of failure, the SECM will enter a "Reduced Power" mode. In this mode, the power output of the engine is limited by reducing the maximum throttle position allowed.
3. In some cases, the SECM will shut the engine down. This is accomplished by stopping ignition, turning off the fuel, and disabling the throttle.

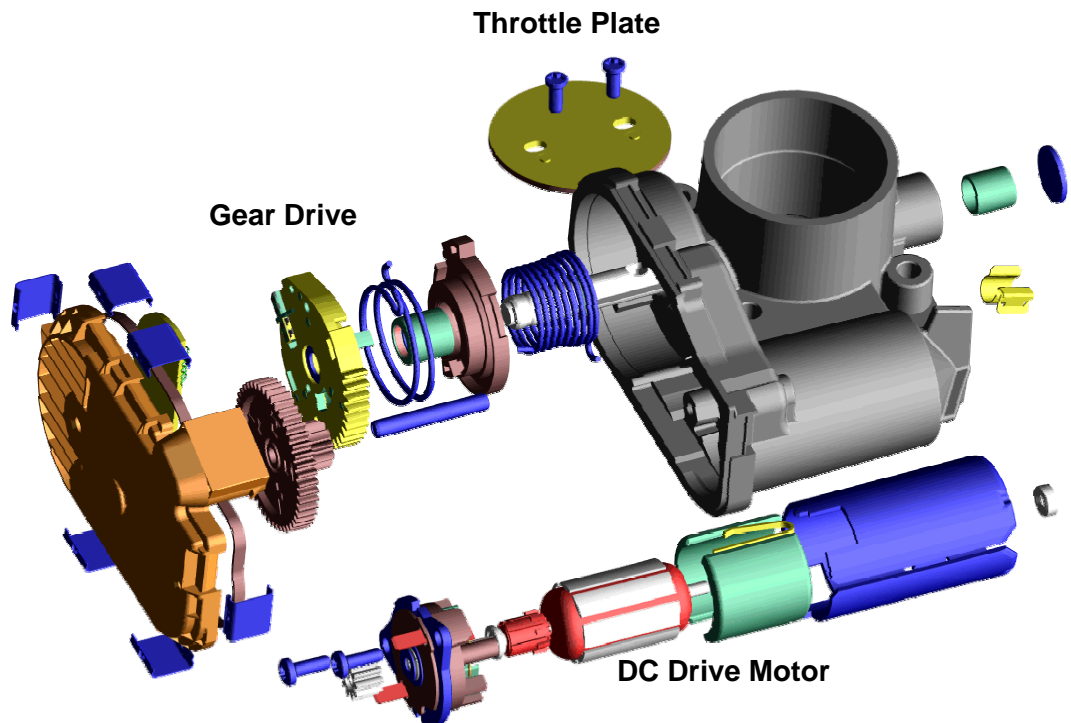

Picture courtesy of Robert Bosch GmbH

Figure 15. Throttle Body Assembly Exploded View

## Ignition System

Spark-ignited engines require accurate control of spark timing and spark energy for efficient combustion. The MI-07 ignition system provides this control. The system consists of the following components:

- SECM
- Ignition coil drivers \*
- Ignition coil(s) \*
- Crankshaft position sensor \*
- Crankshaft timing wheel \*
- Spark plugs \*

(\* ) Customer-supplied components

The SECM, through use of embedded control algorithms and calibration variables, determines the proper time to start energizing the coil and fire the spark plug. This requires accurate crank/camshaft position information, an engine speed calculation, coil energy information, and target spark timing. The SECM provides a TTL compatible signal for spark control. The coil must contain the driver circuitry necessary to energize the primary spark coil otherwise an intermediary coil driver device must be provided. The SECM controls spark energy (dwell time) and spark discharge timing.

### GM 4.3L V-6 ENGINE FUEL SYSTEM OPTIONS

General Motors (GM) industrial engines have the capability of being fueled with propane or natural gas. Propane and natural gas have higher octane ratings than gasoline, but they also have lower lubricity, so engines must be designed specifically to handle the increased frictions associated with these fuels.

The 4.3L V-6 engine versions are:

- LT (propane only) / EST ignition system
- AC (bi-fuel) / HVS ignition system

### GM Delco EST Ignition System

Used on LT propane only engines

The MI-07 system is capable of operating with either a distributor based ignition system or a distributorless ignition system. The current application uses a distributor based ignition system. The distributor will have no internal advance mechanisms giving the SECM consistent authority over ignition timing. The spark is sent to the appropriate cylinder in the conventional way via the rotor arm and spark plug wires. The SECM uses the signal from the GM Delco Ignition Module to determine the engine position and RPM at any time. It uses this information together with the information from the TPS sensor and TMAP to calculate the appropriate ignition timing settings.

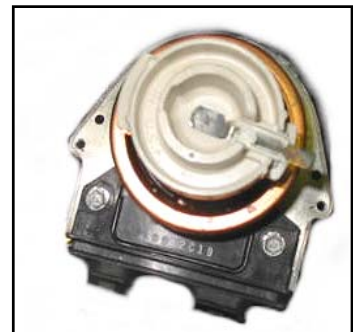

The GM distributor used in the Delco EST ignition system, incorporates a variable reluctance (VR) sensor, which transmits a reference signal to the GM ignition module located on the distributor. A variable reluctance sensor is an electromagnetic device consisting of a permanent magnet surrounded by a winding of wire. The sensor is used in conjunction with a ferrous signal rotor on the distributor shaft. The signal rotor has six lobes, one for each cylinder. Rotation of the signal rotor near the tip of the sensor changes the magnetic flux, creating an analog voltage signal in the sensor coil.

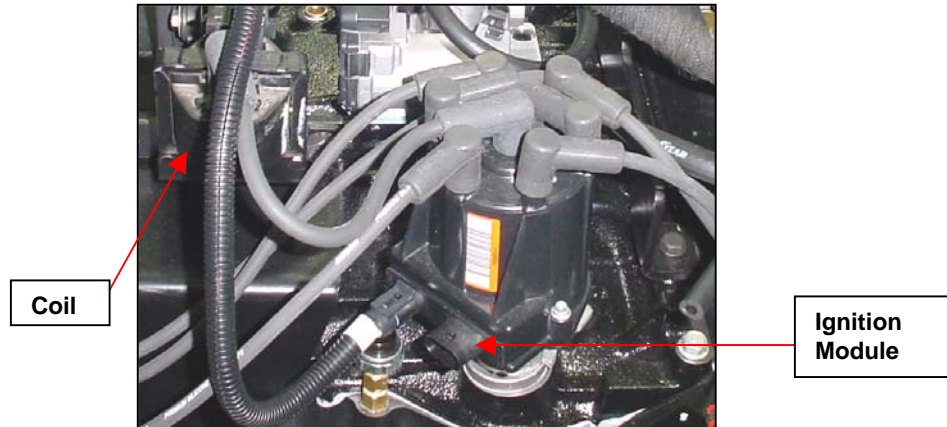

The rising edge of the VR signal is converted to a rising 5-volt signal by the ignition module. As the VR signal passes back through zero volts, a falling edge is created producing a square wave or digital signal, similar to the signal produced by a Hall effect sensor. This falling edge signal provides a stable engine position reference at all engine speeds for the SECM.

### HVS Ignition System

Used on AC bi-fuel engines

The High Voltage Switch (HVS) ignition system used on the AC engine version is very similar to that used in the EST system with a few caveats. The ignition module has been replaced with a High Voltage Switch that is located near the coils instead of inside the distributor. The distributor does still put out a cam sync signal. Note that the High Voltage Switch will not run a default spark advance map if the EST line is disconnected. The distributor is cosmetically different, but still functions identically to the distributor in the EST system, so you can still check the spark timing with the cylinder number 1 secondary wire.

## Exhaust System

### Heated Exhaust Gas Oxygen Sensors (HEGO)

The MI-07 system utilizes two HEGO (O<sub>2</sub>) sensors. One sensor is a pre-catalyst sensor that detects the amount of oxygen in the exhaust stream and is considered the primary control point. Based upon the O<sub>2</sub> sensor feedback, the MI-07 system supplies a stoichiometric air-fuel ratio to the catalytic converter. The catalytic converter then reduces emissions to the required levels. The second sensor is a post-catalyst sensor that detects the amount of oxygen after the catalyst. This sensor is used as a secondary control point to adjust the pre-catalyst setpoint to ensure proper catalyst conversion efficiency.

Once a HEGO sensor reaches approximately 600°F (316°C), it becomes electrically active. The concentration of oxygen in the exhaust stream determines the voltage produced. If the engine is running rich, little oxygen will be present in the exhaust and voltage output will be relatively high. Conversely, in a lean situation, more oxygen will be present and a smaller electrical potential will be noticed.

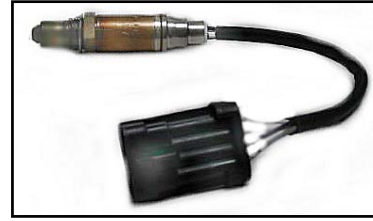

Figure 16. HEGO (O2) Sensor

In order for the sensor to become active and create an electrical signal below 600°F (316°C) a heated element is added to the sensor housing. Two wires provide the necessary 12 Vdc and ground signal for the heater element. A fourth wire provides an independent ground for the sensor. The pre-catalyst sensor heater is powered by the main power relay and is always powered. The post-catalyst sensor heater is powered from an additional relay that is controlled by the SECM. This relay is only energized when the SECM calculates that water condensation in the exhaust system and catalytic muffler prior to the sensor should be evaporated. This is to avoid thermal shock of the sensor that could prematurely fail the sensor.

The HEGO stoichiometric air-fuel ratio voltage target is approximately 500 mV and changes slightly as a function of speed and load. When the pre-catalyst HEGO sensor sends a voltage signal less than 450 mV the SECM interprets the air-fuel mixture as lean. The SECM then decreases the PWM duty cycle sent to the fuel trim valves in order to increase the fuel pressure to the mixer inlet; thus richening air-fuel mixture. The opposite is true if the SECM receives a voltage signal above 450 mV from the HEGO. The air-fuel mixture would then be interpreted as being too rich and the SECM would increase the duty cycle of the trim valves.



#### CAUTION

**The HEGO sensors are calibrated to work with the MI-07 control system. Use of alternate sensors may impact performance and the ability of the system to diagnose rich and lean conditions.**

### Catalytic Muffler

In order to meet 2007 emission requirements a 3-way catalyst is necessary.

The MI-07 control system monitors the exhaust stream pre and post catalyst and uses this information to control the air-fuel mixture. By using the signals from the HEGOs, the SECM can increase or decrease the amount of oxygen in the exhaust by modulating the FTVs and adjusting the air-fuel ratio. This control scheme allows the SECM to make sure that the engine is running at the correct air to fuel ratio so that the catalyst can perform as required to meet the emissions certification.

## SECM

The Woodward Small Engine Control Module (SECM) controller has full authority over spark, fuel and air. Utilizing a Freescale micro controller, the SECM has 48 pins of I/O and is fully waterproof and shock hardened. To optimize engine performance and drivability, the SECM uses several sensors for closed loop feedback information. These sensors are used by the SECM for closed loop control in three main categories:



- Fuel Management
- Load/Speed Management
- Ignition Management

The SECM monitors system parameters and stores any out of range conditions or malfunctions as faults in SECM memory. Engine run hours are also stored in memory. Stored fault codes can be displayed on the Malfunction Indicator Light (MIL) as flash codes or read by the MI-07 Service Tool software through a CAN (Controller Area Network) communication link.

Constant battery power (12 Vdc) is supplied through the fuse block to the SECM and the main power relays. Upon detecting a key-switch ON input, the SECM will fully power up and energize the main power relays. The energized main power relays supply 12 Vdc power to the heated element of the oxygen sensors, fuel lock-off, fuel trim valves (FTVs), crank sensor, cam sensor, and the ignition coils. The SECM supplies voltage to the electronic throttle actuator, oil pressure switch, fuel temperature sensor, and the coolant temperature sensor. Transducer or sensor power (+ 5 Vdc) is regulated by the SECM and supplied to the manifold temperature/air pressure (TMAP) sensor, throttle position sensor (TPS), and the accelerator pedal position sensors (APP1 & APP2). The SECM provides a transducer ground for all the sensors, and a low side driver signal controlling the fuel lock-off, MIL, and FTVs.

### Fuel Management

During engine cranking at startup, the SECM provides a low side driver signal to the fuel lock-off, which opens the lock-off allowing liquid propane to flow to the N-2007 regulator. A stall safety shutoff feature is built into the SECM to close the lock-off in case of a stall condition. The SECM monitors three engine states:

Crank, when the crankshaft position sensor detects any engine revolutions

Stall, when the key is in the ON position but the crankshaft position sensor detects no engine revolutions

Run state, when the engine reaches pre-idle RPM.

When an operator turns on the key switch the lock-off is opened but if the operator fails to crank the engine, the SECM will close the lock-off after 5 seconds.

To maintain proper exhaust emission levels, the SECM uses a heated exhaust gas oxygen sensor (HEGO) mounted before the catalyst, to measure exhaust gas content in the LP gas system. Engine speed is monitored by the SECM through a variable reluctance (VR) sensor or Hall-Effect type sensor. Intake manifold air temperature and absolute pressure are monitored with a (TMAP) sensor. The HEGO voltage is converted to an air/fuel ratio value. This value is then compared to a target value in the SECM. The target value is based on optimizing catalyst efficiency for a given load and speed. The SECM then calculates any corrections that need to be made to the air/fuel ratio.

The system operates in open loop fuel control until the engine has done a certain amount of work. This ensures that the engine and HEGO are sufficiently warmed up

to stay in control. In open loop control, the FTV duty cycle is based on engine speed and load. Once the HEGO reaches operating temperature the fuel management is in closed loop control for all steady state conditions, from idle through full throttle. In closed loop mode, the FTV duty cycle is based on feedback from the HEGO sensor. The system may return to open-loop operation when engine load or engine speed vary beyond a chosen threshold.

The SECM makes any necessary corrections to the air-fuel ratio by controlling the inlet fuel pressure to the air-fuel mixer. Reducing the fuel pressure leans the air/fuel mixture and increasing the fuel pressure enriches the air-fuel mixture. Control is achieved by modulating the fuel trim valves.

## Speed Management

Drive-by-wire refers to the fact that the MI-07 control system has no throttle cable from the foot pedal to the throttle body. Instead, the SECM is electronically connected both to the foot pedal assembly and the throttle body. The SECM monitors the foot pedal position and controls the throttle plate by driving a DC motor connected to the throttle. The DC motor actuates the throttle plate to correspond to the foot pedal position when the operator depresses the pedal. The SECM will override the pedal command above a maximum engine speed and below a minimum idle speed.

The use of electronic throttle control (ETC) ensures that the engine receives only the correct amount of throttle opening for any given situation, greatly improving idle quality and drivability.

Two throttle position sensors (TPS1 and TPS2), which are integral to the drive-by-wire (DBW) throttle assembly, provide feedback for position control by monitoring the exact position of the throttle valve. See **Figure 18**.

SECM self-calibration and “cross checking” compares both signals and then checks for errors.



Figure 17. Foot Pedal

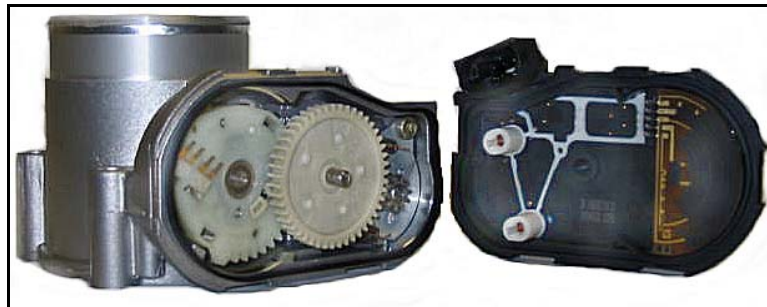

Figure 18. Throttle Position Sensor (TPS) on DV-E5 Throttle



### NOTE

The DV-E5 throttle is not a serviceable assembly. If a TPS sensor fails, the assembly should be replaced.



## ENGINE SPEED GOVERNING

The MI-07 system also performs minimum (min) and maximum (max) speed governing through the SECM and DBW throttle. For min governing, or idle speed control, the idle speed is fixed by the SECM. Unlike a mechanical system, the idle speed is not adjustable by the end user. The idle speed is adjusted by the SECM based on engine coolant temperature. At these low engine speeds, the SECM uses spark and throttle to maintain a constant speed regardless of load.

The MI-07 system eliminates the need for air velocity governors. This substantially increases the peak torque and power available for a given system as shown in **Figure 19**. When the engine speed reaches the max governing point the speed is controlled by closing the DBW throttle. Using the DBW throttle as the primary engine speed control allows for a smooth transition into and out of the governor. If excessive over speed is detected, the engine is shut down.

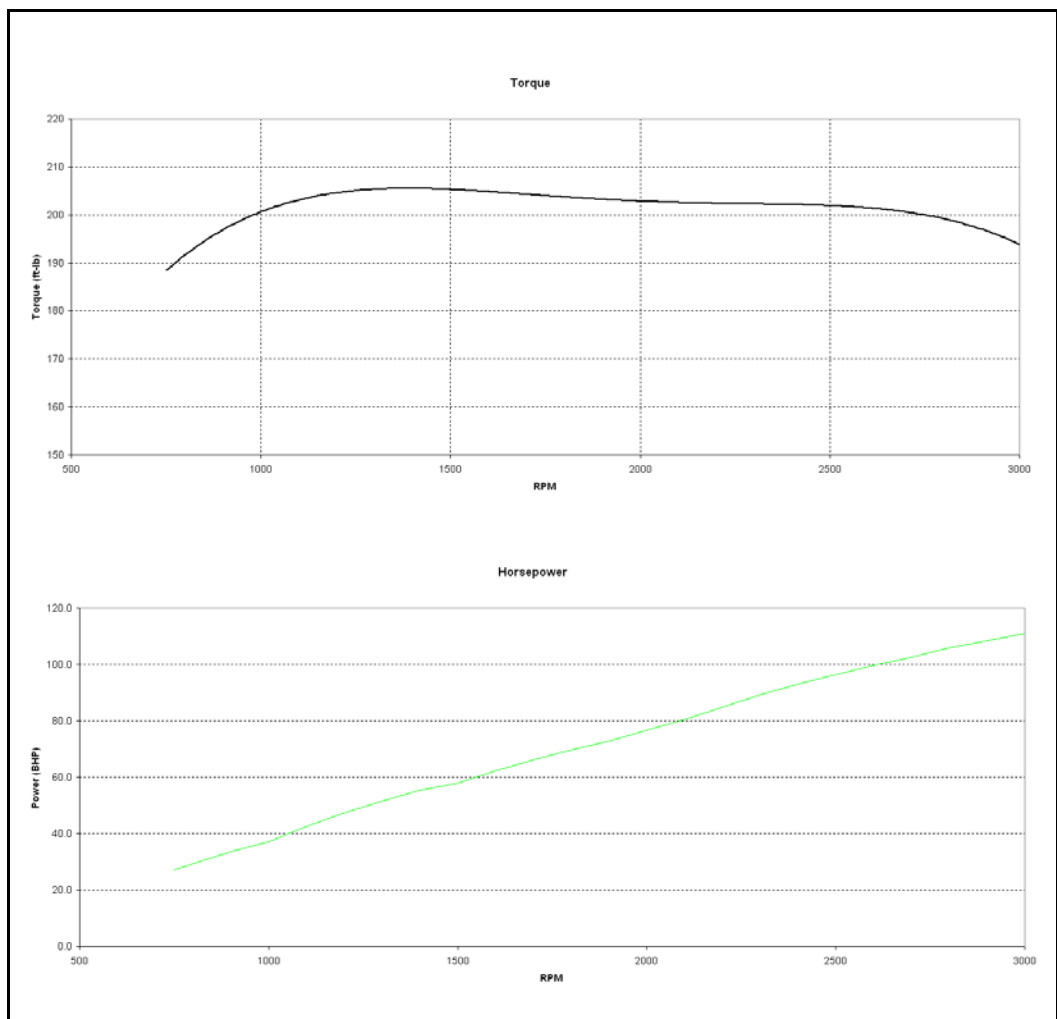

Figure 19. Peak Torque and Power Available with MI-07 System

## Drive-By-Wire Signal Flow Process

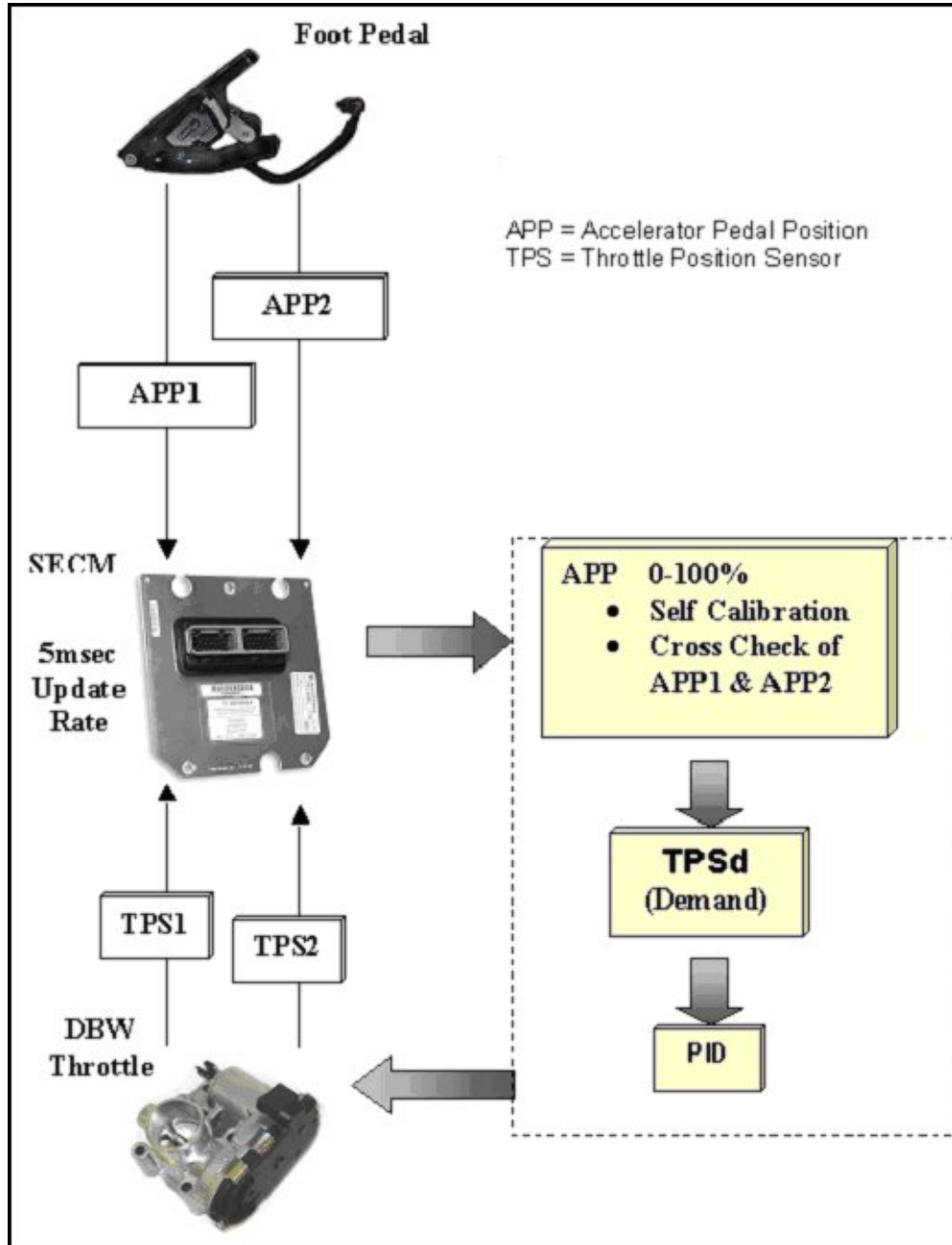

Figure 20. Drive-By-Wire Signal Flow Process

**Figure 20** describes the signal flow process of the MI-07 DBW section. The foot pedal assembly uses two potentiometers to detect pedal position. These two signals, accelerator pedal position 1 (APP1) and accelerator pedal position 2 (APP2) are sent directly to the SECM. The SECM uses a series of algorithms to self calibrate and cross check the signals from the pedal assembly. A demand position for the throttle will then be derived and sent to the throttle as a throttle position sensor demand (TPSd). This signal will be processed through a PID (Proportional, Integral, Derivative) controller in the SECM to achieve the appropriate motor-current response then passed to the throttle. The throttle moves to the commanded position and provides a feedback signal from the throttle position sensors (TPS1 and TPS2) to the SECM.



## Ignition Management

In the normal course of events, with the engine operating at the correct temperature in defined conditions, the SECM will use load and engine speed to derive the correct ignition timing. In addition to load and speed there are other circumstances under which the SECM may need to vary the ignition timing, including low engine coolant temperature, air temperature, start-up, and idle speed control.

## SECM Electrical Mounting Recommendations

In order to prevent the possibility of any SECM malfunctions due to EMI/RFI emissions, engine packagers and OEMs should follow industry "best practices" and the SECM mounting and harness recommendations listed below:

- The SECM should be mounted in a location that minimizes the amount of EMI the module is exposed to by locating it as far as practical from all high tension components, such as ignition coils, distributors, spark plug wires, etc. It is recommended that the SECM be mounted at least 29.5" (749 mm) away from the distributor and ignition coil, and at least 20" (508 mm) from the nearest plug wire.
- All wiring harnesses should be routed to minimize coupling (both radiated and conducted), and be securely fastened to minimize movement and maintain proper clearance between the SECM and all ignition system components.
- The OEM must ensure that a high-quality ground connection between the SECM and battery negative (-) is provided and can be maintained for the useful life of the vehicle. This may require the use of star-type washers on all ground lug connections between the SECM and the battery and/or special preparation of all mating surfaces that complete the ground connection in order to ensure that the connection is sound.

Engineering judgment must be exercised on all applications to determine if appropriate measures have been implemented to minimize EMI exposure to the SECM and associated cabling. The above recommendations do not provide any guarantee of proper system performance.

## SECM / Sensors

The 48-pin Small Engine Control Module (SECM) and sensors provide the computational power, algorithm logic, sensor inputs and control outputs to control the system. The SECM receives signals from the sensors, digitizes these signals, and then, through algorithms and calibration maps, computes the desired output response to effect control of fuel, spark and air to the engine. The SECM also provides a variety of other functions and features. These include system monitoring and diagnostics to aid in maintaining efficient system operation and auxiliary control.



SECM/sensor inputs and control output specifications are specific to the application, but include a selection of the following:

### Analog Inputs

The 48-pin SECM is equipped with sufficient analog inputs for the following sensors.

- **Manifold Absolute Pressure (MAP)** 1bar MAP, 0 to 5 V
- **Manifold Air Temperature (MAT)**  
-40°F to 266°F (-40°C to 130°C) range, 48 kohm to 85 ohm sensor range
- **Throttle Position Sensor 1&2 (TPS1 & TPS2)** 0 to 5 V
- **Foot Pedal Position 1&2 (FPP1 & FPP2)** 0 to 5 V
- **Coolant Temperature Sensor (CTS)**  
-40°F to 266°F (-40°C to 130°C) range, 48K ohm to 85 ohm sensor range
- **Fuel Temperature Sensor (FTS)**  
-40°F to 266°F (-40°C to 130°C) range, 48K ohm to 57 ohm sensor range
- **HEGO (3)** 0 to 1 V
- **Auxiliary Analog Input (2)** 0 to 5 V
- **Battery Voltage (Vbatt) (1)** 8-18 V

With the exception of battery voltage, all inputs are 0-5 Vdc, ground referenced. Resolution should be 0.1% or better. Accuracy should be 2% or better.

### Frequency/Position Inputs

- **Crankshaft position**  
Variable reluctance (2-wire, 200 Vpp max) or 0-5 V Hall Effect with calibration selectable pull-up resistor for open collector sensors  
Permits speed resolution of 0.25 rpm and crankshaft position resolution of 0.5°
- **Camshaft position**  
Variable reluctance (2-wire, 200 Vpp max) or 0-5 V Hall Effect with calibration selectable pull-up resistor for open collector sensors.

### Digital Inputs

- **Oil pressure switch**  
Normally open, internal pull-up resistor provided to detect external switch to ground
- **Transmission oil temperature switch**  
Normally open, internal pull-up resistor provided to detect external switch to ground

- **Ground speed select switch**  
Permits selecting two different maximum engine speeds
- **Vswitched**  
Switched battery voltage

### Outputs

- **FTV drivers (2)**  
10A peak, 45V max. To drive an on/off fuel trim valve with a minimum impedance of 5 ohms  
Capable of continuous on-time  
Drive circuit designed for minimum turn-on /turn-off delay  
FTVs will be pulse width modulated between 8 and 40 Hz with a minimum pulse width resolution of 50 usec
- **Fuel lock-off solenoid valve**  
Low side switch, 10A peak, 4A continuous 45 V max
- **Electronic Spark Timing (EST) (4)**  
TTL compatible outputs  
Software configured for coil-on-plug ignition system
- **Throttle control (1)**  
H-Bridge, 5A peak, 2.5A continuous at 2500 Hz PWM includes current feedback for diagnostic purposes.
- **MIL (malfunction indicator lamp)**  
Low side switch, sufficient to drive a 7W incandescent lamp continuously
- **CANBus**  
CAN 2.0b serial communication for J1939 communications, programming and diagnostics. Requires proper termination resistance per CAN 2.0b.

---

## SECM-48 Wiring Diagram

**CAUTION—PROPER WIRING**

To prevent system faults be sure to follow good wiring practices. Poor wiring may cause unexpected or intermittent failures not related to MI-07 components.

**NOTE**

Always refer to MOR-furnished wiring diagrams for your specific application.

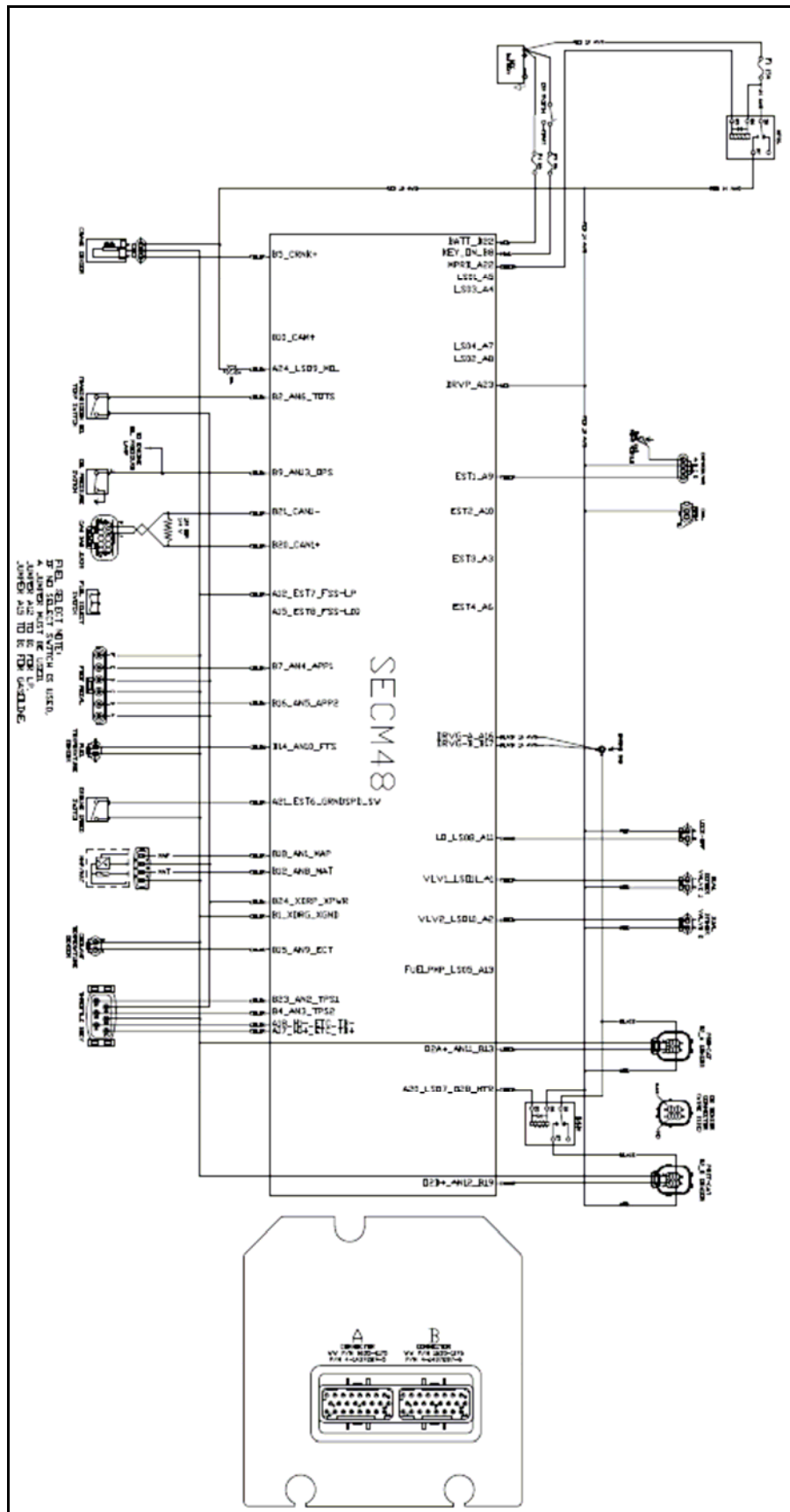

DWG NO. 9930-1062

Figure 21. SECM Wiring Diagram for LP Certified System

## Chapter 2. Specifications

### LP Fuel System Requirements

|   |   |
|---|---|
| <b>Operating Temperature</b>                      | -20 °F to 221°F [-29 °C to 105 °C]  |
| <b>Long-term Storage Temperature</b>              | -40 °F to 140 °F [-40 °C to 60 °C]  |
| <b>Short-term Storage Temperature (Heat Soak)</b> | ≤ 257 °F [125 °C]   |
| <b>LPG Composition Requirements</b>               | HD5 / HD10 LPG. Failure to use fuel compliant with HD5 or HD10 standards will void the user warranty. |
| <b>Fuel Filter Micron Size</b>                    | 10 micron or better at 99% efficiency   |

### Environmental / Electrical Specifications

|                                      |   |
|--------------------------------------|---|
| <b>Ambient Operating Temperature</b> | -20 °F to 221°F [-29 °C to 105 °C]  |
| <b>LPG Fuel Temperature</b>          | -20 °F to 120 °F [-29 °C to 49 °C]<br>(Due to the low vapor pressure of LPG below -20 °F (-29 °C), repeated cranking to start the engine may be required) |
| <b>Operating Voltage</b>             | 8-16 Vdc  |
| <b>Over Voltage Operation</b>        | 18 Vdc for less than 5 minutes<br>24 Vdc for less than 1 minute   |

## N-2007 Pressure Regulator Specifications

|   |  |
|---|--|
| <b>Fuel Supply Pressure</b>                   | 10 psi to 250 psi (68.95 kPa to 1723.69 kPa)   |
| <b>Fuel Inlet Fitting</b>                     | 1/4" NPT   |
| <b>Fuel Outlet Fitting</b>                    | Two 3/4" NPT fittings with one plugged and one 1/8" NPT fitting with plug  |
| <b>Fuel Supply Temperature at Tank Outlet</b> | -20 °F to 120 °F [-29 °C to 49 °C]   |
| <b>Primary Pressure Tap</b>                   | 1/8" NPT with plug   |
| <b>Max Flow</b>                               | 50 lbm/hr LPG  |
| <b>Coolant Flow to Vaporizer</b>              | > 1.0 gpm/100bhp, equipped with 140 °F (60 °C) thermostat  |
| <b>Fuel Outlet Pressure Setpoints</b>         | -0.7 ± 0.2 inH <sub>2</sub> O @ 1.7 lbm/hr LPG<br>(-1.744 ± 0.498 mbar) @ 1.7 lbm/hr LPG)<br>-2.0 ± 0.2 inH <sub>2</sub> O @ 50 lbm/hr LPG<br>(-4.982 ± 0.498 mbar) @ 50 lbm/hr LPG)           |
| <b>Mounting</b>                               | Regulator should be installed with centerline of outlet at least 15° below horizontal to permit drainage of any liquid precipitates from LPG fuel.<br>Diaphragm should be vertically oriented. |

## CA100 Mixer Specifications

|   |   |
|---|---|
| <b>Fuel</b>                                 | LPG   |
| <b>Fuel Inlet Fitting</b>                   | 1/2" NPT<br>Fuel inlet fitted with Delphi temperature sensor  |
| <b>Air Intake Flange</b>                    | 2.25" (57.15mm) ID inlet, four #10-24 screws in<br>1.94" (49.28mm) square pattern   |
| <b>Mixer Mounting Flange</b>                | 1.87" (47.49mm ID outlet, four #12-24 screws<br>arranged in a rectangular pattern   |
| <b>Reference Pressure Ports</b>             | Two 1/8-NPT ports. Pressure readings must be<br>identical within 0.25 inH <sub>2</sub> O (0.623 mbar) at all<br>airflows. |
| <b>Air Valve Vacuum (AVV)<br/>Port Size</b> | 1/4-28 UNF  |
| <b>Fuel Inlet Adjustments</b>               | None  |
| <b>Idle Air Adjustment</b>                  | None  |
| <b>Mounting</b>                             | Suitable for on-engine mounting in vertical<br>orientation  |

## Electronic Throttle System Specifications

|   |          |
|---|----------|
| <b>Minimum Electrical<br/>Resistance of Throttle Actuator</b> | 1.5 ohms |
|---|----------|



## SECM Specifications

|   |  |
|---|--|
| <b>Operating Temperature</b>                      | -20 °F to 221°F [-29 °C to 105 °C]   |
| <b>Long-term Storage Temperature</b>              | -40 °F to 140 °F [-40 °C to 60 °C]   |
| <b>Short-term Storage Temperature (Heat Soak)</b> | ≤ 257 °F [125 °C]  |
| <b>Operating Voltage</b>                          | 8-16 Vdc<br>SECM microprocessor may reset at voltages below 6.3 Vdc                              |
| <b>Operating Environment</b>                      | On-engine mounting, underhood automotive<br>Capable of withstanding spray from a pressure washer |

## Fuel Trim Valve (FTV) Specifications

|                          |   |
|--------------------------|---|
| <b>Actuator Type</b>     | On/off two-position valve compatible with LPG |
| <b>Operating Voltage</b> | 8-16 Vdc                                      |

## Ignition System Specifications

|   |                                    |
|---|------------------------------------|
| <b>Coil Type Inductive</b>                        | Inductive                          |
| <b>Coil Supply Voltage</b>                        | 8-16 Vdc                           |
| <b>Minimum Open Circuit Voltage</b>               | > 30 kV                            |
| <b>Minimum Coil Energy</b>                        | 35 mJ                              |
| <b>Minimum Coil Energy</b>                        | 4 msec                             |
| <b>Maximum Dwell Time</b>                         | -20 °F to 221°F [-29 °C to 105 °C] |
| <b>Operating Temperature</b>                      | -40 °F to 140 °F [-40 °C to 60 °C] |
| <b>Long-term Storage Temperature</b>              |                                    |
| <b>Short-term Storage Temperature (Heat Soak)</b> | ≤ 257 °F [125 °C]                  |

---

## System Control Performance Specifications

### Power /Torque

The MI-07 system maximizes engine power and torque while meeting customer-specific needs for emissions, fuel consumption, durability, and drivability. Bear in mind that engine power is dependent on many variables other than the fuel control system, i.e., compression ratio, friction, valve timing, etc.

### Exhaust Emissions

MI-07 is capable of meeting EPA 2007 LSI engine emission standards when operating properly with an approved three-way catalyst. Emission standards must be met on both the LSI engine off-highway transient emissions test cycle and the ISO 8178 type C2 steady-state emissions test cycle.

The fuel control logic employs a closed-loop exhaust gas oxygen control algorithm in order to compensate for fuel system tolerances, aging, altitude, and fuel composition. The algorithm utilizes dual heated exhaust gas oxygen (HEGO) sensors with an output that switches high and low at stoichiometry. When operated with LPG, the control logic compensates for variations in fuel temperature as measured at the mixer inlet.

### Drivability / Transient Response

The engine will meet requirements of the EPA LSI engine transient emissions test cycle. It should start, run, accelerate, decelerate, and stop without hesitation or miss-fire.

### Low Idle Speed

The low idle speed setpoint ranges between 500 rpm and 800 rpm, as defined by the OEM during calibration.

### Maximum Speed / High Idle

The maximum governed speed setpoint ranges between 1800 rpm and 3000 rpm, as defined by the OEM during calibration.

## Chapter 3.

# Recommended Maintenance

Suggested maintenance requirements for an engine equipped with an MI-07 fuel system are contained in this section. The operator should, however, develop a customized maintenance schedule using the requirements listed in this section and any other requirements listed by the engine manufacturer.

### Maintenance Tests & Inspections

#### Test Fuel System for Leaks

- Obtain a leak check squirt bottle or pump spray bottle.
- Fill the bottle with an approved leak check solution.
- Spray a generous amount of the solution on the fuel system fuel lines and connections, starting at the storage container.
- Wait approximately 15-60 seconds, then perform a visual inspection of the fuel system. Leaks will cause the solution to bubble.
- Listen for leaks
- Smell for LPG odor which may indicate a leak
- Repair any leaks before continuing.
- Crank the engine through several revolutions. This will energize the fuel lock-off and allow fuel to flow to the pressure regulator/convertor. Apply additional leak check solution to the regulator/ convertor fuel connections and housing. Repeat leak inspection as listed above.
- Repair any fuel leaks before continuing.



#### Inspect Engine for Fluid Leaks

- Start the engine and allow it to reach operating temperatures.
- Turn the engine off.
- Inspect the entire engine for oil and/or coolant leaks.
- Repair as necessary before continuing.

#### Inspect Vacuum Lines and Fittings

- Visually inspect vacuum lines and fittings for physical damage such as brittleness, cracks and kinks. Repair/replace as required.
- Solvent or oil damage may cause vacuum lines to become soft, resulting in a collapsed line while the engine is running.
- If abnormally soft lines are detected, replace as necessary.

#### Inspect Electrical System

- Check for loose, dirty or damaged connectors and wires on the harness including: fuel lock-off, TMAP sensor, O2 sensors, electronic throttle, control relays, fuel trim valves, crank position sensor, and cam position sensor.
- Repair and/or replace as necessary.

## Inspect Foot Pedal Operation

- Verify foot pedal travel is smooth without sticking.

## Check Coolant Level

- The items below are a general guideline for system checks. Refer to the engine manufacturer's specific recommendations for proper procedures.
- Engine must be off and cold.

**WARNING—PROPER USE**

Never remove the pressure cap on a hot engine.

- The coolant level should be equal to the "COLD" mark on the coolant recovery tank.
- Add approved coolant to the specified level if the system is low.

## Inspect Coolant Hoses

- Visually inspect coolant hoses and clamps. Remember to check the two coolant lines that connect to the pressure regulator/converter.
- Replace any hose that shows signs of leakage, swelling, cracking, abrasion or deterioration.

## Inspect Battery System

- Clean battery outer surfaces with a mixture of baking soda and water.
- Inspect battery outer surfaces for damage and replace as necessary.
- Remove battery cables and clean, repair and/or replace as necessary.

## Inspect Ignition System

- Remove and inspect the spark plugs. Replace as required.
- Inspect the ignition coil for cracks and heat deterioration. Visually inspect the coil heat sink fins. If any fins are broken replace as required.

## Replace Spark Plugs

- Using a gentle twisting motion, remove the high voltage leads from the spark plugs. Replace any damaged leads.
- Remove the spark plugs.
- Gap the new spark plugs to the proper specifications.
- Apply anti-seize compound to the spark plug threads and install.
- Re-install the high voltage leads.

**CAUTION**

Do not over tighten the spark plugs.

## Replace LP Fuel Filter Element

Park the lift truck in an authorized refueling area with the forks lowered, parking brake applied and the transmission in Neutral.

1. Close the fuel shutoff valve on the LP-fuel tank. Run the engine until the fuel in the system runs out and the engine stops.
2. Turn off the ignition switch.
3. Scribe a line across the filter housing covers, which will be used for alignment purposes when re-installing the filter cover.

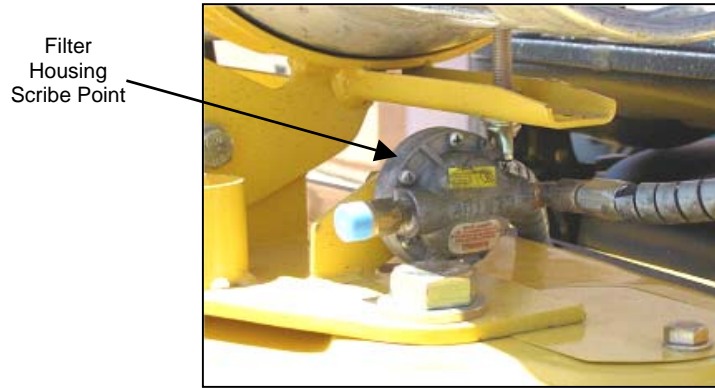

### FUEL FILTER DISASSEMBLY (Steps 4-7)

4. Remove the cover retaining screws (1).
5. Remove top cover (2), magnet (3), spring (4), and filter element (7) from bottom cover (5).
6. Replace the filter element (7).
7. Check bottom cover O-ring seal (6) for damage. Replace if necessary.
8. Re-assemble the filter assembly aligning the scribe lines on the top and bottom covers.
9. Install the cover retaining screws, tightening the screws in an opposite sequence across the cover.
10. Open the fuel valve by slowly turning the valve counterclockwise.
11. Crank the engine several revolutions to open the fuel lock-off. **DO NOT START THE ENGINE.** Turn the ignition key switch to the off position.
12. Check the filter housing, fuel lines and fittings for leaks. Repair as necessary.

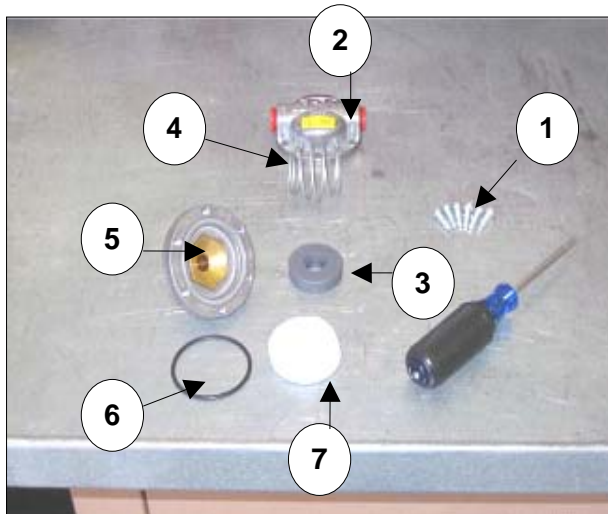

## Testing Fuel Lock-off Operation

- Start engine.
- Locate the electrical connector for the fuel lock (A).
- Disconnect the electrical connector.
- The engine should run out of fuel and stop within a short period of time.



### NOTE

The length of time the engine runs on trapped fuel vapor increases with any increase in distance between the fuel lock-off and the pressure regulator/converter.

- Turn the ignition key switch off and re-connect the fuel lock-off connector.

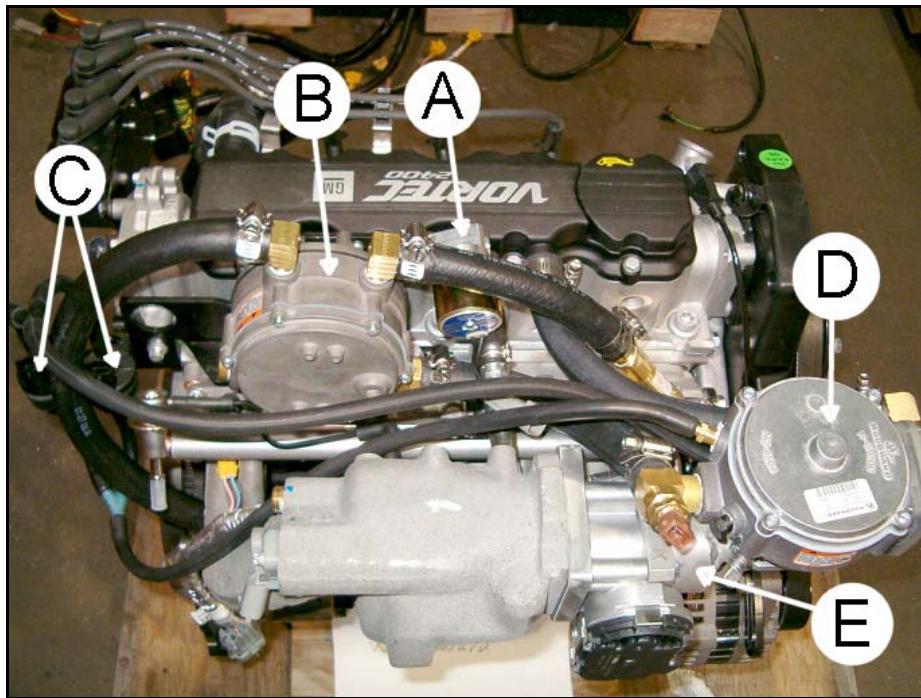

Figure 22. MI-07 System Installed on GM 4.3L Engine

## Pressure Regulator/Converter Inspection

- Visually inspect the pressure regulator/converter (B) housing for coolant leaks.
- Refer to Chapter 4 if the pressure regulator/converter requires replacement.

## Fuel Trim Valve Inspection (FTV)

- Visually inspect the fuel trim valves (C) for abrasions or cracking. Replace as necessary.
- To ensure a valve is not leaking a blow-by test can be performed.
  1. With the engine off, disconnect the electrical connector to the FTVs.
  2. Disconnect the vacuum line from the FTVs to the pressure regulator/converter at the converter's tee connection.
  3. Lightly blow through the vacuum line connected to the FTVs. Air should not pass through the FTVs when de-energized. If air leaks past the FTVs when de-energized, replace the FTVs.

### Inspect Air/Fuel Valve Mixer Assembly

- Refer to Chapter 4 for procedures regarding the LP mixer (D).

### Inspect for Intake Leaks

- Visually inspect the intake throttle assembly (E), and intake manifold for looseness and leaks. Repair as necessary.

### Inspect Throttle Assembly

- Visually inspect the throttle assembly motor housing for coking, cracks, and missing cover-retaining clips. Repair and/or replace as necessary.

**NOTE**

Refer to Chapter 4 for procedures on removing the mixer and inspecting the throttle plate.

### Checking the TMAP Sensor

- Verify that the TMAP sensor (F) is mounted tightly into the manifold or manifold adapter (E), with no leakage.
- If the TMAP is found to be loose, remove the TMAP retaining screw and the TMAP sensor from the manifold adapter.
- Visually inspect the TMAP O-ring seal for damage. Replace as necessary.
- Apply a thin coat of an approved silicon lubricant to the TMAP O-ring seal.
- Re-install the TMAP sensor into the manifold or manifold adapter and securely tighten the retaining screw.

### Inspect Engine for Exhaust Leaks

- Start the engine and allow it to reach operating temperatures.
- Perform visual inspection of exhaust system from the engine all the way to the tailpipe. Any leaks, even after the post-catalyst oxygen sensor, can cause the sensor output to be effected (due to exhaust pulsation entraining air upstream). Repair any/all leaks found. Ensure the length from the post-catalyst sensor to tailpipe is the same as original factory.
- Ensure that wire routing for the oxygen sensors is still keeping wires away from the exhaust system. Visually inspect the oxygen sensors to detect any damage.



## Maintenance Schedule

**NOTE**

The MI-07 fuel system was designed for use with LPG fuel that complies with HD5 or HD10 LPG fuel standards. Use of non-compliant LPG fuel may require more frequent service intervals and will disqualify the user from warranty claims.

| CHECK POINT   | INTERVAL HOURS                               |                            |                             |                              |                              |                            |
|---|--|----------------------------|-----------------------------|------------------------------|------------------------------|----------------------------|
|   | Daily  | Every 250 Hours or 1 month | Every 500 Hours or 3 months | Every 1000 Hours or 6 months | Every 1500 Hours or 9 months | Every 2500 Hours or 1 year |
| <b>General Maintenance</b>  |  |                            |                             |                              |                              |                            |
| Test fuel system for leaks.   | Prior to any service or maintenance activity |                            |                             |                              |                              |                            |
| Inspect engine for fluid leaks.   | X  |                            |                             |                              |                              |                            |
| Inspect all vacuum lines and fittings.  |  |                            | X                           |                              |                              |                            |
| Inspect electrical system; check for loose, dirty, or damaged wires and connections.  |  |                            | X                           |                              |                              |                            |
| Inspect isolation mounts on engine control module for cracks and wear; replace as necessary.  |  |                            | X                           |                              |                              |                            |
| Inspect all fuel fittings and hoses.  |  |                            |                             | X                            |                              |                            |
| Inspect foot pedal travel and operation.  | X  |                            |                             |                              |                              |                            |
| Replace timing belt   |  |                            |                             |                              |                              | X                          |
| Check for MIL lamp test at key-on. If MIL lamp remains illuminated (indicating a fault), use pedal to recover fault code(s). Repair faults. | X  |                            |                             |                              |                              |                            |
| <b>Engine Coolant</b>   |  |                            |                             |                              |                              |                            |
| Check coolant level.  | X  |                            |                             |                              |                              |                            |
| Inspect coolant hoses and fittings for leaks, cracks, swelling, or deterioration.   |  |                            |                             | X                            |                              |                            |
| <b>Engine Ignition</b>  |  |                            |                             |                              |                              |                            |
| Inspect battery for damage and corroded cables.   |  |                            |                             |                              |                              | X                          |
| Inspect ignition system.  |  |                            |                             |                              | X                            |                            |
| Replace spark plugs   |  |                            |                             |                              | X                            |                            |
| <b>Fuel Lock-Off/Filter</b>   |  |                            |                             |                              |                              |                            |
| Replace LP fuel filter element.   |  |                            |                             | X                            |                              |                            |
| Inspect lock-off and fuel filter for leaks.   |  |                            |                             | X                            |                              |                            |
| Ensure lock-off stops fuel flow when engine is off.   |  |                            |                             | X                            |                              |                            |

| CHECK POINT  | INTERVAL HOURS        |                            |                             |                              |                              |                            |
|--|-----------------------|----------------------------|-----------------------------|------------------------------|------------------------------|----------------------------|
|  | Daily                 | Every 250 Hours or 1 month | Every 500 Hours or 3 months | Every 1000 Hours or 6 months | Every 1500 Hours or 9 months | Every 2500 Hours or 1 year |
| <b>Pressure Regulator/Converter</b>  |                       |                            |                             |                              |                              |                            |
| Test regulator pressures.  |                       |                            |                             | X                            |                              |                            |
| Inspect pressure regulator vapor hose for deposit build-up. Clean or replace as necessary.                   |                       |                            |                             | X                            |                              |                            |
| Inspect regulator assembly for fuel/coolant leaks.   |                       |                            |                             | X                            |                              |                            |
| <b>Fuel Trim Valve</b>   |                       |                            |                             |                              |                              |                            |
| Inspect valve housing for wear, cracks or deterioration.   |                       |                            |                             | X                            |                              |                            |
| Ensure valve seals in the closed position when the engine is off.  |                       |                            |                             | X                            |                              |                            |
| Replace FTV.   | When indicated by MIL |                            |                             |                              |                              |                            |
| <b>Carburetor</b>  |                       |                            |                             |                              |                              |                            |
| Check air filter indicator.  | X                     |                            |                             |                              |                              |                            |
| Check for air leaks in the filter system.  |                       |                            |                             | X                            |                              |                            |
| Inspect air/fuel valve mixer assembly for cracks, loose hoses, and fittings. Repair or replace as necessary. |                       |                            | X                           |                              |                              |                            |
| Check for vacuum leaks in the intake system including manifold adapter and mixer to throttle adapter.        |                       |                            |                             |                              |                              | X                          |
| Repair or replace throttle assembly.   | When indicated by MIL |                            |                             |                              |                              |                            |
| Inspect air filter.  |                       |                            | X                           |                              |                              |                            |
| Replace air filter element.  |                       |                            |                             | X                            |                              |                            |
| Check TMAP sensor for tightness and leaks.   |                       |                            |                             |                              |                              | X                          |
| <b>Exhaust &amp; Emission</b>  |                       |                            |                             |                              |                              |                            |
| Inspect engine for exhaust leaks.  | X                     |                            |                             |                              |                              |                            |
| Replace PCV valve and breather element.  |                       |                            |                             |                              |                              | X                          |
| Replace HEGO sensors   | When indicated by MIL |                            |                             |                              |                              |                            |

## Chapter 4. Installation Procedures



### WARNING—PROPER USE

- LP gas is highly flammable. To prevent personal injury, keep fire and flammable materials away from the lift truck when work is done on the fuel system.
- Gas vapor may reduce oxygen available for breathing, cause headache, nausea, dizziness and unconsciousness and lead to injury or death. Always operate the forklift in a well ventilated area
- Liquid propane may cause freezing of tissue or frostbite. Avoid direct contact with skin or tissue; always wear appropriate safety protection including gloves and safety glasses when working with liquid propane.



### CAUTION

The regulator/converter and mixer are part of a certified system complying with EPA and CARB 2007 requirements. Only trained, certified technicians should perform disassembly, service or replacement of the regulator/converter or mixer.

## Hose Connections

Proper operation of the closed loop control greatly depends on the correct vacuum hose routing and fuel line lengths. Refer to the connection diagrams below for proper routing and maximum hose lengths when reinstalling system components.

**NOTE:** Preferred mounting of regulator is off engine.

### Hose Specifications

Vacuum hose to comply to SAE 1403 Type I or SAE J30 R7 R8 / EPDM textile reinforced / -40° F to +257° F (-40° C +125° C / Inside Diameter: 7/32" (5.56mm)

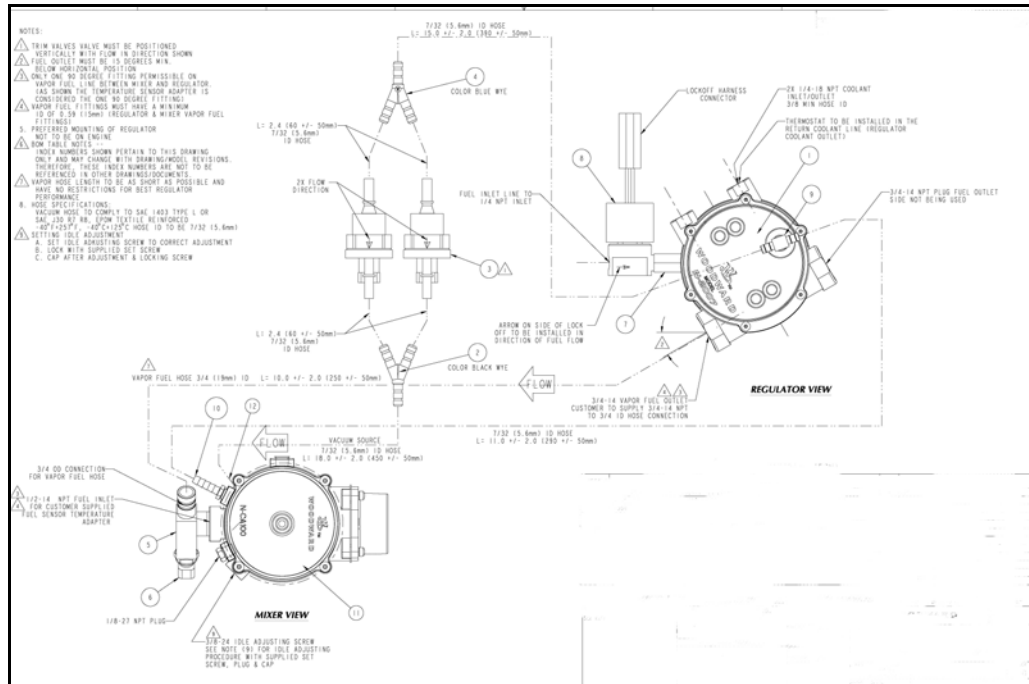

DWG NO 5555-1202

Figure 23. Hose Connections for 4.3L Engine

### DIAGRAM NOTES

- 1 Trim valves must be positioned vertically with flow arrows in position shown
- 2 Fuel outlet must be min 15° below horizontal position
- 3 Only one 90° fitting permissible on vapor fuel line between mixer and regulator (As shown the temp sensor adaptor is considered the one 90° fitting.)
- 4 Vapor fuel fittings (regulator and mixer) must have minimum ID of 0.46" (11.68mm)
- 8 Vapor hose length to be as short as possible and have no restrictions for best regulator performance

- 1 N-2007 Regulator
- 2 Plastic WYE Fitting (black color) for 7/32" (5.56mm) ID Tube Hose
- 3 Valve (TEV Bosch Canister)
- 4 Plastic WYE Fitting (blue color) for 7/32" (5.56mm) ID Tube Hose
- 5 Adapter (temperature sensor)
- 6 Sensor (coolant, temperature)
- 7 Nipple (.625 hex 4mp, 2.5L steel)
- 8 Solenoid (AFS Lock Off Valve)
- 9 Brass Tee Fitting. 1/4 Tube x 1/8 NPTF x 1/4 Tube
- 10 CA100 Mixer
- 11 1/4" (6.35mm) hose barb to 1/8" (3.2mm) male pipe, 125HBL, .062 flow ID
- 12 1/4-28 UNF x 1/4" (6.35mm) hose barb

## Removal and Installation of N-2007 LP Regulator/Converter

Follow the procedures below for removal and reinstallation of the N-2007 regulator.

### N-2007 Removal Steps

Refer to **Figure 24**.

1. Close the liquid outlet valve in the forklift cylinder or fuel storage container.
2. Purge the system of fuel by starting the engine and running until all trapped fuel in the system is exhausted and the engine shuts down.
3. Key switch in "OFF" position.
4. Remove the fuel inlet line (1) from the lock-off, the two vacuum lines (2) from the branch-tee fitting in the regulator vent and disconnect the lock-off connector (3).
5. Remove the four rear-mounting bolts that hold the regulator to the support bracket. This will allow easier access to the remaining hose clamps.
6. Remove the two cooling lines (4) from the regulator. *NOTE: Either drain the coolant system or clamp off the coolant lines as close to the regulator as possible to avoid a coolant spill when these lines are disconnected.*
7. Remove the fuel vapor outlet hose (5) from the regulator.
8. Remove the nipple extension (6) with the lock-off from the regulator.

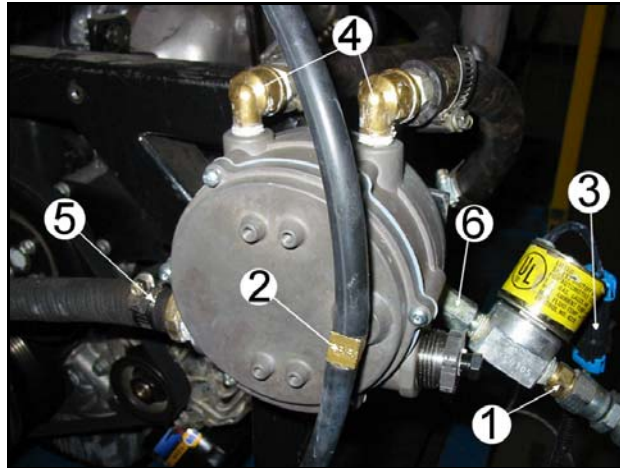

**Figure 24. N-2007 Regulator Installed on Engine**

### N-2007 Installation Steps

Refer to **Figure 27**.

1. Install the nipple extension (6) with the lock-off to the regulator.
2. Install the fuel vapor outlet hose (5) to the regulator.
3. Install the two cooling lines (4) to the regulator.
4. Install the four rear-mounting bolts that hold the regulator to the support bracket. Use a torque wrench and tighten each bolt to 60-70 lbf-in (6.78-7.91 N-m).
5. Install the fuel inlet line (1) to the lock-off, the two vacuum lines (2) to the branch-tee fitting in the regulator vent and re-connect the lock-off connector (3).
6. Open the liquid outlet valve in the forklift cylinder or fuel storage container.

## Removal and Installation of CA100 Mixer

Follow the procedures below for removal and reinstallation of the CA100 mixer.

### CA100 Mixer Removal Steps

Refer to **Figure 25**.

1. Close the liquid outlet valve in the forklift cylinder or fuel storage container.
2. Purge the system of fuel by starting the engine and running until all trapped fuel in the system is exhausted and the engine shuts down.
3. Key switch in "OFF" position.
4. Remove the air cleaner hose (1).
5. Mark the two vacuum lines (2) to the mixer for identification, as they must be reinstalled correctly for proper operation. Remove the two vacuum lines.
6. Remove vapor fuel inlet line (3) from the fuel temperature sensor fitting (4).
7. Disconnect the fuel temperature sensor connector (5).
8. Disconnect the wires leading to the electronic throttle body by pinching the lock tabs on either side of the wiring harness connector. (See **Figure 26** for location of connector.)
9. Loosen the four bolts (6) that secure the mixer/adapter/throttle body assembly to the intake manifold.
10. Remove the mixer (9), the adapter (7), and the throttle body (8) as an assembly by gently pulling upwards. Take care not to drop anything down the intake manifold.
11. Gently wiggle and pull to separate mixer and adapter from the throttle body. Take note of the adapter orientation on the mixer, as it must be reinstalled correctly for proper fit on the throttle.
12. Remove the four mounting screws that attach the throttle body adapter to the mixer.
13. Remove the fuel temperature sensor (not shown) from the tee (4).
14. Remove the fuel temperature sensor fitting from the mixer. Take note of the fitting's orientation on the mixer, as it must be reinstalled correctly for proper fit.
15. Remove the short vacuum port barb from the mixer. (See **Figure 27** for location of port barb on mixer.)

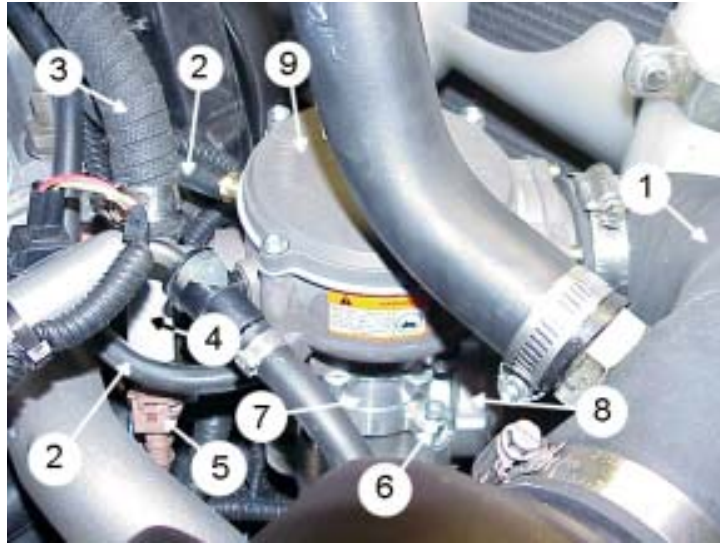

Figure 25. CA100 Mixer Installed on Engine



Figure 26. O-Ring and Spacer Within Mixer Adapter Assembly

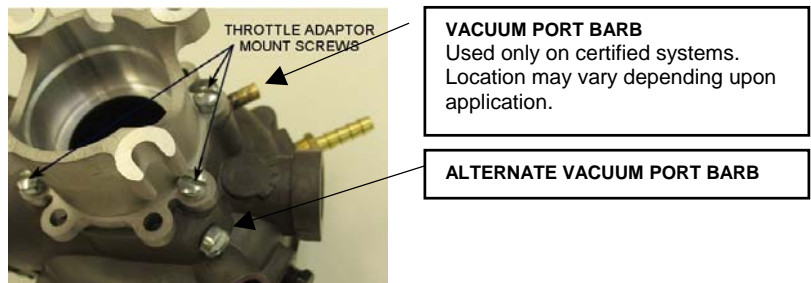

Figure 27. Throttle Adaptor Mount Screws

## CA100 Mixer Installation Steps

Refer to **Figure 25**.

1. Install the vacuum port barb onto the mixer (9).
2. Install the fuel temperature sensor fitting (4) onto the mixer.
3. Install the fuel temperature sensor into the fitting.
4. Install the four mounting screws that attach the throttle adapter (7) to the mixer. See **Figure 27**. Torque bolts to 30-40 lbf-in (3.39-4.52 N-m).
5. Position the mixer/adapter assembly onto the throttle body (8), then drop in the four mounting bolts (6) and gently push down on the assembly until it rests on the throttle body. Be careful not to pinch the O-ring.  
(See **Figure 26**.)
6. Attach the mixer/throttle body assembly to the intake manifold, making sure gasket is in place. Tighten the four mounting bolts.
7. Connect the wiring harness to the throttle body. (See **Figure 27** for location of connector.) Connect the fuel temperature sensor connector (5) to the sensor.
8. Install the vapor fuel inlet line (3) to the fuel temperature sensor fitting.
9. Install the two vacuum lines (2) to the mixer using the previous marks for identification. Vacuum lines must be installed correctly for proper operation.
10. Install the air cleaner hose (1).



## Chapter 5.

# Tests and Adjustments



### WARNING—PROPER USE

- LP gas is highly flammable. To prevent personal injury, keep fire and flammable materials away from the lift truck when work is done on the fuel system.
- Gas vapor may reduce oxygen available for breathing, cause headache, nausea, dizziness and unconsciousness and lead to injury or death. Always operate the forklift in a well ventilated area
- Liquid propane may cause freezing of tissue or frostbite. Avoid direct contact with skin or tissue; always wear appropriate safety protection including gloves and safety glasses when working with liquid propane.



### CAUTION

The regulator/converter and mixer are part of a certified system complying with EPA and CARB 2007 requirements. Only trained, certified technicians should perform disassembly, service or replacement of the regulator/converter or mixer.

## N-2007 Regulator Service Testing

For checking the N-2007 regulator/converter operation, the following tests can be performed (See Chapter 4 for removal/installation of the N-2007 regulator). To check the secondary regulation (output) a simple vacuum hand pump can be used to simulate the vacuum signal transmitted from the air/fuel mixer when the engine is running. See listing below for required hardware.

### Break-Off Test

#### Secondary Stage Test Hardware

1. Hand vacuum pump
2. Regulator vapor outlet test fitting 3/4" NPT x 1/4" hose barb
3. Union Tee 1/4" NPT with three 1/4" NPT x 1/4" hose barb
4. Vacuum hose
5. 0-3" WC Magnehelic gauge (inches of water column)

#### Secondary Stage (Break-Off) Test

1. Connect the vacuum pump, the Magnehelic gauge and the regulator vapor outlet to the Union Tee fitting (**Figure 33**). Make sure there is no leakage at any of the fittings.
2. Using the vacuum pump slowly apply enough vacuum to measure above -2" WC on the gauge. This vacuum signal opens the secondary valve in the N-2007 regulator/converter.
3. Release the vacuum pump lever and you will see the gauge needle start falling back toward zero. When the pressure drops just below the specified break-off pressure (-0.5 +/- 0.35 " WC) of the secondary spring, the needle should stop moving.
4. At this point the secondary valve should close. If the secondary valve seat or the secondary diaphragm is leaking the gauge needle will

continue to fall toward zero (proportional to the leak size). An excessively rich air/fuel mixture can be caused by a secondary valve seat leak and the regulator should be replaced.

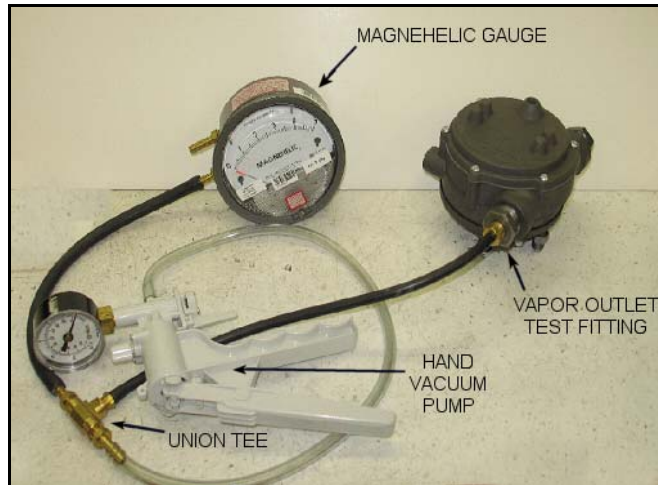

Figure 28. Secondary Stage Test Connection

## Pressure Test

### Primary Stage Test Hardware

1. Shop air pressure regulator adjusted to 100 psi
2. Shop air hose fitting (1/4" NPT to air hose)
3. Air hose
4. Test gauge fitting (1/16" NPT x 1/4" hose barb)
5. Vacuum hose or vinyl tubing
6. 0-60" WC Magnehelic gauge (inches of water column)

### Primary Stage Pressure Test

1. Remove the primary test port plug from the side of the regulator and install the 1/16" NPT hose barb fitting (**Figure 29**).
2. Connect a compressed air line (shop air ~100 psi) to the liquid propane fuel inlet of the N-2007 regulator (**Figure 29**).



Figure 29. Primary Stage Test Connection

3. Apply compressed air, wait for air to exit the hose barb in the test port, and then connect the Magnehelic gauge (**Figure 30**) to the hose barb using the vacuum hose or vinyl tubing. This prevents the gauge from reading maximum pressure due to the large velocity of compressed air entering the primary chamber.
4. Make sure there is no leakage at any of the fittings. The static pressure should read between 40-60" of water column on the Magnehelic gauge and maintain a constant pressure for 60 seconds.



**Figure 30. Magnehelic Gauge Connection to Hose Barb**

5. If the pressure reading begins to **increase**, a leak is most likely present at the primary valve, either the primary valve o-ring or the valve itself. If a leak is present the regulator should be replaced.
6. If the pressure begins to **decrease**, the secondary seat is probably not making an adequate seal and is leaking. The regulator should be replaced.
7. If the test is successful, re-install the primary test port plug and check the fittings for leaks. See Chapter 4 for installation of the N-2007 regulator.



#### NOTE

The N-2007 primary stage pressure can also be tested at idle on a running engine. The N-2007 primary pressure should be between 40 inH<sub>2</sub>O (99.635 mbar) and 55 inH<sub>2</sub>O (136.999 mbar) at 750 rpm, idle.



#### WARNING

- LP gas is highly flammable. To prevent personal injury, keep fire and flammable materials away from the lift truck when work is done on the fuel system.
- Gas vapor may reduce oxygen available for breathing, cause headache, nausea, dizziness and unconsciousness and lead to injury or death. Always operate the forklift in a well ventilated area

Liquid propane may cause freezing of tissue or frostbite. Avoid direct contact with skin or tissue; always wear appropriate safety protection including gloves and safety glasses when working with liquid propane.

## AVV (Air Valve Vacuum) Testing

### Purpose of Test

Check for excessive or inadequate pressure drop across CA100 mixer.

### AVV Test Hardware

1. Union Tee fitting, 1/4" (6.35mm) NPT with three 1/4" (6.35mm) NPT x 1/4" (6.35mm) hose barbs
2. Vacuum hose
3. 0-20" H<sub>2</sub>O differential pressure Magnehelic gauge

### AVV Test

1. Install Union Tee fitting in the hose between the FTVs and the AVV fitting. Connect this fitting to the low pressure port of the Magnehelic gauge (**Figure 31**).
2. Leave high pressure port of the Magnehelic gauge exposed to ambient pressure (**Figure 31**).
3. With the engine fully warmed up and running at idle (750 rpm) place the transmission in Neutral. The AVV should be between 5" and 8" H<sub>2</sub>O of pressure vacuum.
4. If the measured pressure drop is excessively high, check for sticking or binding of the diaphragm air valve assembly inside the mixer. Replace mixer if necessary.
5. If the measured pressure drop is low, check for vacuum leaks in the manifold, throttle, mixer, TMAP sensor and attached hoses.

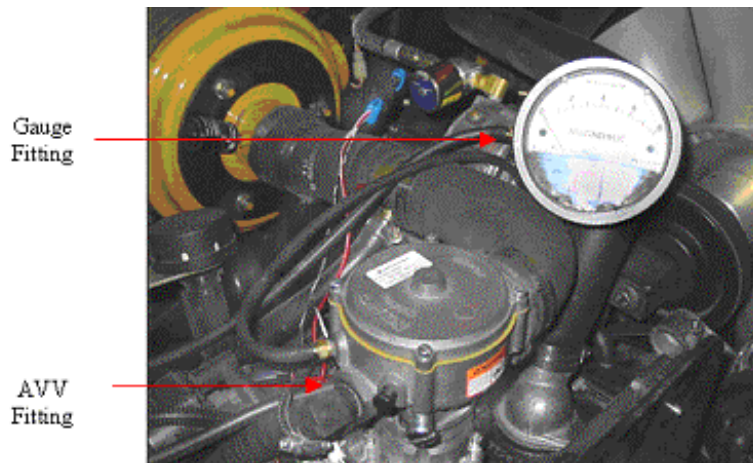

Figure 31. Magnehelic Gauge Connection

## Ignition Timing Adjustment

With the MI-07 system, ignition-timing advance is controlled by the SECM.

The initial ignition timing needs to be set by the MOR. This setup requires a specific technique for each engine installation.

## Connection of MI-07 Service Tool

To use the Service Tool, a USB (Universal Serial Bus) to CAN (Controller Area Network) communication adapter by KVaser will be required along with a Crypt Token (**Figure 32**). The Crypt Token acts as a security key allowing the laptop to retrieve the necessary data from the SECM.

1. Install the Crypt Token in an available USB port in the computer (**Figure 33**).
2. With the ignition key in the OFF position, connect the KVaser communication cable from a second USB port on the computer to the CAN communications cable on the engine.  
*(\*If your laptop computer does not have a second USB port an appropriate USB hub will need to be used).*
3. Connect a timing light to the engine.
4. Turn the ignition key to the ON position (**Do Not Start the Engine**).
5. Launch the MotoView program on your computer and open the Service Tool display (**Figure 34**).



**Figure 32. KVaser  
Communication Adapter**



**Figure 33. Crypt Token Installed on Laptop**



**Figure 34. Opening the Service Tool Display**

## Idle Mixture Adjustment

**NOTE**

Be sure engine is fully warm (ECT>167°F [75°C]) before performing the idle mixture adjustment.

The CA100 mixer requires adjustment of the idle mixture screw to assure optimal emissions and performance. This adjustment accounts for minor part-to-part variations in the fuel system and assures stable performance of the engine at idle. Once adjusted, the idle mixture screw is sealed with a tamper proof cap, after which it need not be adjusted for the life of the vehicle.

Therefore, the only situations in which the idle mixture screw needs to be adjusted are when the engine is initially fitted with a fuel system at the factory and following the field replacement of the mixer. Under these situations, follow the procedures below for adjustment of the idle mixture screw.

### Factory Test Preparation:

1. Install the MI-07 fuel system, wiring harness and SECM-48 control module on the engine.
2. All coolant hoses should be attached, filled with coolant and bled to remove any air.
3. Attach LPG fuel lines.
4. Attach wiring harness to battery power.
5. Attach exhaust system.
6. If present, set fuel select switch to LPG fuel.

When operated at the factory, it is critical to simulate the airflow found on a forklift at idle as nearly as possible in order to achieve the proper air valve lift in the mixer. It may be necessary to place a load on the engine to achieve the required airflow without overspeeding the engine. Means of achieving this load include:

- a) Place an electrical load on the alternator. The alternator should be able to briefly hold loads of approximately 1.2 kW.
- b) Attach the engine to a dynamometer.



## Factory Adjustment Procedure:

**NOTE**

Be sure engine is fully warm (ECT>167°F [75°C]) before performing the idle mixture adjustment.

1. Operating the engine on LPG fuel, start the engine and permit the engine to warm up until the coolant temperature (ECT on Mototune display) is approximately 167°F (75 °C).
2. Set APP input to minimum.
3. Adjust the load until engine speed reaches 750 rpm.
4. Mototune display parameter LP Fuel Control must display “Closed Loop.”
5. Use the Mototune Service Tool to monitor Duty Cycle % on the Mototune display.
6. To adjust the idle mixture screw, use a 5mm hex or Allen-type wrench. Turning the screw in (clockwise) should increase the duty cycle; turning the screw out (counter-clockwise) should decrease the duty cycle.
7. Adjust the idle mixture screw on the mixer until a reading of **40-45%** is reached for the FTV Duty Cycle in Closed Loop Idle (**Figure 35**).

|                        |           |     |
|------------------------|-----------|-----|
| AFR CONTROL            | LP        |     |
| LP Fuel Cntrl          | Open-Loop | Phi |
| Duty Cycle %           | 0.00      |     |
| LP Adapt Offset        | 0.00      |     |
| O2 Value               | 1.00      |     |
| AFR CONTROL            | Gasoline  |     |
| Gasoline Fuel Cntrl    | Open-Loop | Phi |
| O2 Value               | 1.00      |     |
| Gasoline Adapt Factor  | 0.00000   |     |
| INJ 1 mg per Injection |           |     |

Figure 35 shows a screenshot of the Mototune Service Tool interface. The interface displays two sections: 'LP' and 'Gasoline'. The 'LP' section shows 'LP Fuel Cntrl' as 'Open-Loop', 'Duty Cycle %' as '0.00', 'LP Adapt Offset' as '0.00', and 'O2 Value' as '1.00'. The 'Gasoline' section shows 'Gasoline Fuel Cntrl' as 'Open-Loop', 'O2 Value' as '1.00', 'Gasoline Adapt Factor' as '0.00000', and 'INJ 1 mg per Injection' as an empty field. Red arrows point from the 'Duty Cycle %' value to a red box labeled 'Duty Cycle%'. Another red arrow points from the 'Open-Loop' status to a red box labeled 'Closed Loop'.

**Figure 35. FTV Duty Cycle Percentage Displayed on Service Tool**

8. Use the accelerator pedal to increase RPM above idle momentarily (*rev the engine*) then release the pedal to return to idle RPM. The duty cycle setting should remain within the adjustment range (**40-45%**). Place your thumb over the adjustment port for a more accurate reading by preventing air from leaking past the mixture adjustment screw, which may cause the duty cycle to decrease.
9. Use the Mototune Service Tool to lock the FTV duty cycle. Set display parameter DitherValveDC\_ovr = locked (displayed in screen tab Manual Override 1 under AFR Trim Vales, select “locked” under box labeled Lock DC%).
10. Use the Mototune Service Tool to monitor throttle position (TPS1) and Exhaust gas oxygen equivalence ratio (“O2 Value” in Figure 1). While monitoring O2, slowly increase the pedal input (APP) to achieve a TPS1 value of 15%.
11. Use the Mototune Service Tool to unlock the FTV duty cycle. Set display parameter DitherValveDC\_ovr = unlocked (displayed in screen tab Manual Override 1 under AFR Trim Vales, select “unlocked” under box labeled Lock DC%).

12. If at any time in step 10, O2 was greater than 1.2 go to step 13. If O2 remained below 1.2, proceed to Step 15.
13. Adjust the idle mixture screw on the mixer until a reading of **50-55%** is reached for the FTV Duty Cycle in Closed Loop Idle (**Figure 35**).
14. Use the accelerator pedal to increase RPM above idle momentarily (*rev the engine*) then release the pedal to return to idle RPM. The duty cycle setting should remain within the adjustment range (**50-55%**). Place your thumb over the adjustment port for a more accurate reading by preventing air from leaking past the mixture adjustment screw, which may cause the duty cycle to decrease.

**NOTE**

If the FTV Duty Cycle reading is **NOT** between 25-60%, check for possible vacuum leaks, manifold leaks, or a faulty mixer.

15. Turn the ignition key to the **OFF** position to shut down the engine.
16. Install the tamper proof cap on the idle mixture screw adjustment port using a large pin punch, so that no further adjustments can be made (**Figure 36**).



**Figure 36. Installing Tamper Proof Cap**

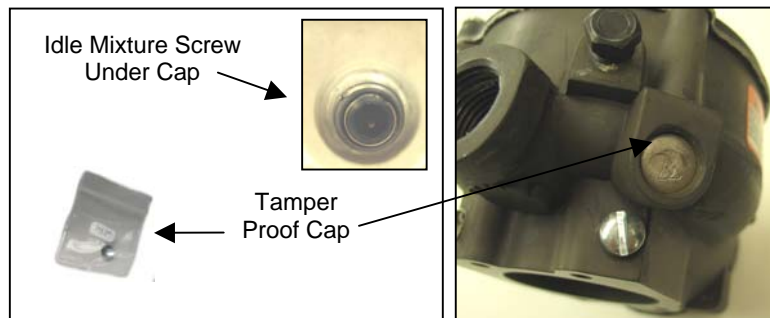



## Field Adjustment Procedure:

The idle mixture adjustment should only be necessary on a new mixer that does not have the tamper proof cap installed. The method for making the idle mixture adjustment to a running engine is to use the Service Tool software by connecting a laptop computer to the SECM. If you do not have the Service Tool a multimeter capable of measuring duty cycle, such as a Fluke 87 III, can be used. If using a multimeter, connect the meter positive lead to between battery positive and the meter negative to the FTV signal wire. For the Fluke 87, press the "RANGE" button until 4 or 40 appears in the lower right-hand corner of the display. Press the "Hz" button twice so that the percent sign (%) appears on the right-hand side of the display. The multimeter will then read the duty cycle percentage the same as the Service Tool shown in **Figure 35**.

1. After installing a new mixer, operate the engine on LPG fuel. Start the engine and permit it to warm up until the coolant temperature (ECT on Mototune display) is approximately 167°F (75 °C).
2. Place the transmission in Neutral.
3. Mototune display parameter LP Fuel Control must display "Closed Loop".
4. Use the Mototune Service Tool to monitor Duty Cycle % on the Mototune display.
5. To adjust the idle mixture screw, use a hex or Allen-type wrench. Turning the screw in (clockwise) should increase the duty cycle; turning the screw out (counterclockwise) should decrease the duty cycle.
6. Adjust the idle mixture screw on the mixer until a reading of **45-55%** is reached for the FTV Duty Cycle in Closed Loop Idle (**Figure 35**). If engine idle performance is unstable screw the idle screw in slightly to see if stability is obtained, but in no case should duty cycle exceed 60%.
7. Use the accelerator pedal to increase rpm above idle momentarily (*rev the engine*) then release the pedal to return to idle rpm. The duty cycle setting should remain within the adjustment range (**45-55%**). Place your thumb over the adjustment port for a more accurate reading by preventing air from leaking past the mixture adjustment screw, which may cause the duty cycle to decrease.
8. If the FTV duty cycle reading is above **55%** adjust the idle adjustment screw outward and re-check the duty cycle reading. Continue to do this until the FTV duty cycle reading is within the optimum range (**45-55%**). **DO NOT** adjust the screw so far outward that the tamper proof cap cannot be installed. A duty cycle measurement at Closed Loop Idle of **40-60%** is acceptable if the optimum range of **45-55%** cannot be reached through adjustment. If the FTV duty cycle cannot be adjusted below **60%**, the mixer is faulty and should be replaced.

**NOTE**

If the FTV Duty Cycle reading is **NOT** between 25-60%, check for possible vacuum leaks, manifold leaks, or a faulty mixer.

9. Turn the ignition key to the **OFF** position to shut down the engine.
10. Install the tamper proof cap on the idle mixture screw adjustment port using a large pin punch, so that no further adjustments can be made (**Figure 36**).

# Chapter 6.

## Basic Troubleshooting

### Preliminary Checks

MI-07 systems are equipped with built-in fault diagnostics. Detected system faults can be displayed by the Malfunction Indicator Lamp (MIL) and are covered in Chapter 7, Advanced Diagnostics. However, items such as fuel level, plugged fuel lines, clogged fuel filters, and malfunctioning pressure regulators may not set a fault code and usually can be corrected with the basic troubleshooting steps described on the following pages.

If engine or drivability problems are encountered with your MI-07 system, perform the checks in this section before referring to Advanced Diagnostics.

NOTE: Locating a problem in a propane engine is done exactly the same as with a gasoline engine. Consider all parts of the ignition and mechanical systems as well as the fuel system.

#### BEFORE STARTING . . .

1. Determine that the SECM and MIL light are operating. Verify operation by keying on engine and checking for flash of MIL light.

When the ignition key is turned on, the MIL will illuminate and remain on until the engine is started. Once the engine is started, the MIL lamp will go out unless one or more fault conditions are present. If a detected fault condition exists, the fault or faults will be stored in the memory of the small engine control module (SECM). Once an active fault occurs the MIL will illuminate and remain ON. This signals the operator that a fault has been detected by the SECM.

2. Determine that there are no diagnostic codes stored, or there is a diagnostic code but no MIL light.

#### VISUAL/PHYSICAL CHECK

Several of the procedures call for a "Careful Visual/Physical Check" which should include:

- SECM grounds for being clean and tight
- Vacuum hoses for splits, kinks, and proper connection.
- Air leaks at throttle body mounting and intake manifold
- Exhaust system leaks
- Ignition wires for cracking, hardness, proper routing, and carbon tracking
- Wiring for pinches and cuts

Also check:

- Connections to determine that none are loose, cracked, or missing
- Fuel level in vehicle is sufficient
- Fuel is not leaking
- Battery voltage is greater than 11.5 volts
- Steering, brakes, and hydraulics are in proper condition and vehicle is safe to operate

**NOTE**

The Visual/Physical check is very important, as it can often correct a problem without further troubleshooting and save valuable time.

## Basic Troubleshooting

### Intermittents

An intermittent fault is the most difficult to troubleshoot since the MIL flashes on at random, causing uncertainty in the number of flashes or the conditions present at the time of the fault. Also, the problem may or may not fully turn “ON” the MIL light or store a code.

**Therefore, the fault must be present or able to be recreated in order to locate the problem. If a fault is intermittent, use of diagnostic code charts may result in the unnecessary replacement of good components.**

| CORRECTIVE ACTION   |
|---|
| <p>Most intermittent problems are caused by faulty electrical connections or wiring. Perform careful visual/physical check for:</p> <ul style="list-style-type: none"> <li>• Poor mating of the connector halves or terminal not fully seated in the connector body (backed out)</li> <li>• Improperly formed or damaged terminal. All connector terminals in problem circuit should be carefully reformed or replaced to insure proper contact tension</li> <li>• Loose connections or broken wires</li> <li>• Poor terminal to wire connection crimp</li> </ul>   |
| <p>If a visual/physical check does not find the cause of the problem, perform the following:</p> <ol style="list-style-type: none"> <li>(1) Drive the vehicle with a voltmeter or “Service” tool connected to a suspected circuit. Check if circuit is active and signal is reasonable.</li> <li>(2) Using the “Service” tool, monitor the input signal to the SECM to help detect intermittent conditions.</li> <li>(3) An abnormal voltage, or “Service” reading, when the problem occurs, indicates the problem may be in that circuit.</li> <li>(4) If the wiring and connectors check OK, and a diagnostic code was stored for a circuit having a sensor, check sensor.</li> </ol> |
| <p>An intermittent “Service Engine Soon” light with no stored diagnostic code may be caused by:</p> <ul style="list-style-type: none"> <li>• Ignition coil shortage to ground and arcing at spark plug wires or plugs</li> <li>• MIL light wire to ECM shorted to ground</li> <li>• SECM grounds (refer to SECM wiring diagrams).</li> </ul>  |
| <p>Check for improper installation of electrical options such as lights, 2-way radios, accessories, etc.</p>  |
| <p>EST wires should be routed away from spark plug wires, distributor wires, distributor housing, coil and generator. Wires from SECM to ignition should have a good connection.</p>  |

## Basic Troubleshooting (cont'd.)

**Surges and/or Stumbles**

Engine power varies under steady throttle or cruise. Feels like the vehicle speeds up and slows down with no change in the acceleration pedal.

**PRELIMINARY CHECKS**

Perform the visual checks as described at start of "Basic Troubleshooting" chapter. Be sure driver understands vehicle operation as explained in the operator manual.

| <b>PROBABLE CAUSE</b>       | <b>CORRECTIVE ACTION</b>   |
|-----------------------------|--|
| Oxygen sensor malfunction   | The fuel management should maintain a stoichiometric air-fuel ratio under all steady state operating conditions following engine warmup. Failure of the Pre-catalyst O2 sensor should cause an O2 sensor fault that can be diagnosed with the MIL lamp or Service Tool.  |
| Fuel system malfunction     | <b>NOTE:</b> To determine if the condition is caused by a rich or lean system, the vehicle should be driven at the speed of the complaint. Monitoring pre-catalyst O2 adapts* or dither valve duty cycle will help identify problem.<br>Check fuel supply while condition exists.<br>Check in-line fuel filter. Replace if dirty or plugged.<br>Check fuel pressure.   |
| Ignition system malfunction | Check for proper ignition voltage output using spark tester.<br>Check spark plugs. <ul style="list-style-type: none"> <li>• Remove spark plugs, check for wet plugs, cracks, wear, improper gap, burned electrodes, or heavy deposits.</li> <li>• Repair or replace as necessary.</li> <li>• Check condition of distributor cap, rotor and spark plug wires (where applicable).</li> <li>• Check ignition timing.</li> </ul> |
| Component malfunction       | Check vacuum lines for kinks or leaks.<br>Check alternator output voltage. Repair if less than 9 or more than 16 volts.  |
| Exhaust backpressure        | Check condition of exhaust system.<br>Check backpressure before catalyst. It should be less than 3.5 psig (24.13 kPa).   |

(\*) Refer to **Table 1** for description of gaseous and liquid O2 adapts.

**Related MIL Faults:**

Pre-catalyst O2 sensor errors / O2 control errors

Dither valve DC faults / EST faults / ETC faults

## Basic Troubleshooting (cont'd.)

**Engine Cranking but Will Not Start / Difficult to Start**

Engine cranks OK, but does not start for a long time. Does eventually run, or may start but immediately dies.

| <b>PRELIMINARY CHECKS</b>  |
|--|
| Perform the visual checks as described at start of “ Basic Troubleshooting” chapter. Be sure driver is using correct method to start engine as explained in operator’s manual. Use “clear flood” mode during cranking by fully depressing the pedal and cranking the engine. If engine does not start, continue troubleshooting. |

| <b>PROBABLE CAUSE</b>  | <b>CORRECTIVE ACTION</b>   |
|--|--|
| Fuel container empty   | Check for LPG vapor from LPG liquid outlet valve on tank.<br>Fill fuel container. Do not exceed 80% of liquid capacity.  |
| Liquid valve closed  | Slowly open liquid valve.  |
| Propane excess flow valve closed   | Reset excess flow valve in LPG tank.<br>Close liquid valve. Wait for a “click” sound; slowly open liquid valve.  |
| Plugged fuel line  | Remove obstruction from the fuel line. <ul style="list-style-type: none"> <li>• Close liquid fuel valve.</li> <li>• Using caution, disconnect the fuel line (some propane may escape).</li> <li>• Clear obstruction with compressed air.</li> <li>• Re-connect fuel line.</li> <li>• Slowly open liquid fuel valve.</li> <li>• Leak test.</li> </ul> |
| Clogged fuel filter  | Repair/replace as required.<br><i>See Chapter 3 Fuel Filter replacement.</i>   |
| Faulty vapor connection between the pressure regulator/converter and the mixer | Check connection <ul style="list-style-type: none"> <li>• Verify no holes in hose.</li> <li>• Clamps must be tight.</li> <li>• Look for kinked, pinched and/or collapsed hose.</li> </ul>  |
| Fuel lock-off malfunction  | Repair/replace fuel lock-off.<br><i>See Chapter 3 Fuel Lock-off.</i>   |
| Pressure regulator/converter malfunction                                       | Test regulator/converter operation and pressure.<br><i>See Chapter 5 Tests and Adjustments.</i>  |
| Incorrect air/fuel or ignition/spark control                                   | <i>See Chapter 7 Advanced Diagnostics.</i>   |
| No crankshaft position sensor signal   | Verify the crankshaft position signal is present<br><i>See Chapter 7 Advanced Diagnostics.</i>   |

(continued on next page)

## Basic Troubleshooting (cont'd.)

**Engine Cranking but Will Not Start / Difficult to Start (cont'd.)**

| PROBABLE CAUSE                    | CORRECTIVE ACTION  |
|-----------------------------------|--|
| SECM / control system malfunction | <p>Check Coolant Temperature Sensor using the Service Tool; compare coolant temperature with ambient temperature on cold engine.</p> <p>If coolant temperature reading is 5° greater than or less than ambient air temperature on a cold engine, check resistance in coolant sensor circuit or sensor itself. Compare CTS resistance value to "Diagnostic Aids" chart at end of this section.</p> <p>Verify that there is no code for ETC spring check fault.</p> <p>Check for 0% APP during cranking.</p> <p>Cycle key ON and OFF and listen for throttle check (movement) on key OFF.</p> <p>Check for oil pressure switch faults.</p> <p>Check for sensor "sticking" faults.</p> <p>Check TPS for stuck binding or a high TPS voltage with the throttle closed.</p> |
| Fuel system malfunction           | <p>Check fuel lock off: actuator should turn "ON" for 2 seconds when ignition is turned "ON".</p> <p>Check fuel pressure.</p> <p>Check for contaminated fuel.</p> <p>Check lock off fuses (visually inspect).</p> <p>Check propane tank valve &amp; pickup. A faulty in-tank fuel pump check valve will allow the fuel in the lines to drain back to the tank after engine is stopped. To check for this condition, perform fuel system diagnosis.</p> <p>Check FTV system for proper operation.</p>   |
| Ignition system malfunction       | <p>Check for proper ignition voltage output with spark tester.</p> <p>Check spark plugs. Remove spark plugs, check for wet plugs, cracks, wear, improper gap, burned electrodes, or heavy deposits. Repair or replace as necessary.</p> <p>Check for:</p> <ul style="list-style-type: none"> <li>• Moisture in distributor cap*</li> <li>• Bare or shorted wires</li> <li>• Worn distributor shaft/rotor*</li> <li>• Loose ignition coil ground</li> <li>• Pickup coil resistance and connections</li> </ul> <p>(* ) Where present</p>   |

**Related MIL Faults:**

ETC spring check / ETC faults / EST faults / TPS conflict  
 APP faults / Encoder error / MAP faults / Oil pressure faults

## Basic Troubleshooting (cont'd.)

**Lack of Power, Slow to Respond / Poor High Speed Performance / Hesitation During Acceleration**

Engine delivers less than expected power. Little or no increase in speed when accelerator pedal is pushed down part way. Momentary lack of response as the accelerator is pushed down. Can occur at all vehicle speeds. Usually most severe when first trying to make vehicle move, as from a stop. May cause engine to stall.

**PRELIMINARY CHECKS**

Perform the visual checks as described at start of "Basic Troubleshooting" chapter.  
Drive vehicle; verify problem exists.  
Remove air filter and check for dirt or other means of plugging. Replace if needed.

| PROBABLE CAUSE              | CORRECTIVE ACTION  |
|-----------------------------|--|
| Fuel system malfunction     | Check for restricted fuel filter.<br>Check fuel supply.<br>Check for LPG vapor from LPG liquid outlet valve on tank.<br>Check for contaminated fuel.<br>Check for clogged fuel filter and repair or replace as required. <i>See Chapter 3 Fuel Filter replacement</i><br>Check for plugged fuel line and remove any obstruction from the fuel line: <ul style="list-style-type: none"> <li>• Close liquid fuel valve.</li> <li>• Using caution, disconnect the fuel line (some propane may escape).</li> <li>• Clear obstruction with compressed air.</li> <li>• Re-connect fuel line.</li> <li>• Slowly open liquid fuel valve and leak test.</li> </ul> Check for faulty vapor connection between pressure regulator/converter and mixer: <ul style="list-style-type: none"> <li>• Verify that there are no holes in hose.</li> <li>• Observe that clamps are tight.</li> <li>• Look for kinked, pinched and/or collapsed hose.</li> </ul> Monitor pre-catalyst O <sub>2</sub> with Service Tool.<br>Check for proper pressure regulator operation. <i>See Chapter 5 Test and Adjustments.</i><br>Check for proper air/fuel mixer operation. |
| Ignition system malfunction | Check spark advance for excessive retarded ignition timing. Use Service Tool.<br>Check secondary voltage using an oscilloscope or a spark tester to check for a weak coil.<br>Check spark plug condition.<br>Check poor spark plug primary and secondary wire condition.   |

(continued on next page)



## Basic Troubleshooting (cont'd.)

**Lack of Power, Slow to Respond / Poor High Speed Performance  
Hesitation During Acceleration (cont'd.)**

| PROBABLE CAUSE        | CORRECTIVE ACTION  |
|-----------------------|--|
| Component malfunction | <p>Check SECM grounds for cleanliness and secure connection. See SECM wiring diagrams.</p> <p>Check alternator output voltage. Repair if less than 9 volts or more than 16 volts.</p> <p>Check for clogged air filter and clean or replace as required.</p> <p>Check exhaust system for possible restriction. Refer to Chart T-1 on later pages.</p> <p>Inspect exhaust system for damaged or collapsed pipes.</p> <ul style="list-style-type: none"> <li>• Inspect muffler for heat distress or possible internal failure.</li> <li>• Check for possible plugged catalytic converter by comparing exhaust system backpressure on each side at engine. Check backpressure by removing Pre-catalyst O2 sensor and measuring backpressure with a gauge.</li> </ul> |
| Engine mechanical     | <p>See <i>Engine Manufacturer's Service Manual</i>.</p> <p>Check engine valve timing and compression</p> <p>Check engine for correct or worn camshaft.</p>   |

**Related MIL Faults:**

EST faults  
ETC faults  
ETC spring check  
TPS faults  
APP faults  
Encoder error  
Delayed Shutdown faults

## Basic Troubleshooting (cont'd.)

**Detonation / Spark Knock**

A mild to severe ping, usually worse under acceleration. The engine makes sharp metallic knocks that change with throttle opening (similar to the sound of hail striking a metal roof).

| <b>PRELIMINARY CHECKS</b>  |
|--|
| Perform the visual checks as described at start of " Basic Troubleshooting" chapter. |

| <b>PROBABLE CAUSE</b>       | <b>CORRECTIVE ACTION</b>  |
|-----------------------------|---|
| Fuel system malfunction     | Check for proper fuel level: <ul style="list-style-type: none"> <li>• Check for LPG vapor from LPG liquid outlet valve on tank.</li> <li>• Fill fuel container. Do not exceed 80% of liquid capacity.</li> </ul> Check fuel pressure.<br>To determine if the condition is caused by a rich or lean system, the vehicle should be driven at the speed of the complaint. Monitoring with the Service tool will help identify problem. |
| Cooling system malfunction  | Check for obvious overheating problems: <ul style="list-style-type: none"> <li>• Low engine coolant</li> <li>• Loose water pump belt</li> <li>• Restricted air flow to radiator, or restricted water flow through radiator</li> <li>• Inoperative electric cooling fan</li> <li>• Correct coolant solution should be a mix of anti-freeze coolant (or equivalent) and water</li> <li>• High coolant temperature</li> </ul>          |
| Ignition system malfunction | Check ignition timing.<br>Check spark module wiring.  |
| Exhaust system malfunction  | Check exhaust backpressure.<br>Check for debris clogging the catalyst.<br>Check that pre-catalyst O2 sensor is functioning.   |
| Engine mechanical           | Check for excessive oil in the combustion chamber and/or blow by from excessive PCV flow.<br>Check combustion chambers for excessive carbon build up.<br>Check combustion chamber pressure by performing a compression test.<br>Check for incorrect basic engine parts such as cam, heads, pistons, etc.  |

**Related MIL Faults:**

EST faults

Encoder error

High coolant temperature faults

## Basic Troubleshooting (cont'd.)

**Backfire**

Fuel ignites in intake manifold or in exhaust system, making loud popping noise.

| <b>PRELIMINARY CHECKS</b>   |
|---|
| Perform the visual checks as described at start of "Basic Troubleshooting" chapter.<br>Simulate condition by reviewing operation procedure practiced by vehicle operator. |

| <b>PROBABLE CAUSE</b>       | <b>CORRECTIVE ACTION</b>  |
|-----------------------------|---|
| Fuel system malfunction     | Perform fuel system diagnosis check: <ul style="list-style-type: none"> <li>• Check for fuel leaks</li> <li>• Check for MIL faults</li> <li>• Check for damaged components</li> </ul>   |
| Ignition system malfunction | Check proper ignition coil output voltage with spark tester.<br>Check spark plugs. Remove spark plugs, check for wet plugs, cracks, wear, improper gap, burned electrodes, or heavy deposits. Repair or replace as necessary.<br>Check spark plug wires for crossfire; also inspect distributor cap, spark plug wires and proper routing of plug wires.<br>Check ignition timing. |
| Engine mechanical           | Check compression: look for sticking or leaking valves.<br>Check intake and exhaust manifold for casting flash and gasket misalignment.<br>Refer to Engine Manufacturer's Service Manual.   |

**Related MIL Faults:** EST faults / ETC faults / Encoder error  
Pre-catalyst O2 sensor faults

**Dieseling, Run-on**

Engine continues to run after key is turned "OFF," but runs very roughly. If engine runs smoothly, check ignition switch and adjustment.

| <b>PRELIMINARY CHECKS</b>   |
|---|
| Perform the visual checks as described at start of "Basic Troubleshooting" chapter. |

| <b>PROBABLE CAUSE</b>       | <b>CORRECTIVE ACTION</b>   |
|-----------------------------|--|
| Fuel system malfunction     | Check for fuel leaks.  |
| Ignition switching          | Make sure power to system is shut off when key is in OFF position. |
| Fuel lock off valve         | Make sure lock off valve is closing properly.                      |
| Ignition system malfunction | Check spark advance at idle.                                       |

**Related MIL Faults:** EST faults / ETC faults / Pre-catalyst O2 sensor faults



## Basic Troubleshooting (cont'd.)

**Rough, Unstable, Incorrect Idle, or Stalling**

Engine cranks OK, but does not start for a long time. Does eventually run, or may start but immediately dies.

| <b>PRELIMINARY CHECKS</b>   |
|---|
| Perform the visual checks as described at start of "Basic Troubleshooting" chapter.<br>Check for vacuum leaks.<br>Check that SECM grounds are clean and tight. See SECM wiring diagram. |

| <b>PROBABLE CAUSE</b>              | <b>CORRECTIVE ACTION</b>   |
|------------------------------------|--|
| Fuel system malfunction            | Monitor oxygen feedback to help identify the cause of the problem. If the system is running lean or if the system is running rich evaluate further i.e. dither valve duty cycle.<br>Check for incorrect minimum idle speed that may be caused by foreign material accumulation in the throttle bore, on the throttle valve, or on the throttle shaft.<br>Check for liquid fuel in propane pressure regulator hose. If fuel is present, replace regulator assembly.<br>The pre-catalyst oxygen (O <sub>2</sub> ) sensor should respond quickly to different throttle positions. If it does not, then check the pre-catalyst O <sub>2</sub> sensor for contamination. If the pre-catalyst O <sub>2</sub> sensor is aged or contaminated, the SECM will not deliver correct amount of fuel, resulting in a drivability problem. |
| Fuel container empty               | Check for LPG vapor from LPG liquid outlet valve on tank.<br>Fill fuel container. Do not exceed 80% of liquid capacity.  |
| Ignition system malfunction        | Check ignition system; wires, plugs, etc.  |
| LPG pressure regulator malfunction | Test regulator operation and pressure.<br><i>See Chapter 5 Tests and Adjustments</i>   |
| Air/fuel mixer malfunction         | Check mixer.   |
| Component malfunction              | Check throttle for sticking or binding.<br>Check PCV valve for proper operation by placing finger over inlet hole in valve end several times. Valve should snap back. If not, replace valve.<br>Check alternator output voltage. Repair if less than 9 or more than 16 volts.  |
| Engine mechanical                  | Perform a cylinder compression check.<br><i>See Engine Manufacturer's Service Manual.</i>  |

(continued on next page)

## Basic Troubleshooting (cont'd.)

## Rough, Unstable, Incorrect Idle, or Stalling (cont'd.)

| PROBABLE CAUSE   | CORRECTIVE ACTION  |
|--|--|
| Excess flow valve closed   | Reset excess flow valve. <ul style="list-style-type: none"> <li>• Close liquid valve.</li> <li>• Wait for a "click" sound. Slowly open liquid valve.</li> </ul>  |
| Clogged fuel filter  | Repair/replace as required<br><i>See Chapter 3 Fuel Filter Replacement</i>   |
| Plugged fuel line  | Remove obstruction from the fuel line. <ul style="list-style-type: none"> <li>• Close liquid fuel valve.</li> <li>• Using caution, disconnect the fuel line (some propane may escape).</li> <li>• Clear obstruction with compressed air.</li> <li>• Re-connect fuel line.</li> <li>• Slowly open liquid fuel valve &amp; leak test.</li> </ul>                 |
| Fuel lock-off malfunction  | Repair/replace fuel lock-off.<br><i>See Chapter 3 Fuel Lock-Off.</i>   |
| Faulty vapor connection between the pressure regulator/converter and the mixer | Check connection. <ul style="list-style-type: none"> <li>• Verify no holes in hose.</li> <li>• Clamps must be tight.</li> <li>• Look for kinked, pinched and/or collapsed hose.</li> </ul>   |
| Pressure regulator freezes   | Check level in cooling system: <ul style="list-style-type: none"> <li>• Must be full, check coolant strength</li> <li>• -35°F (-37°C) minimum</li> </ul> Check coolant hoses. <ul style="list-style-type: none"> <li>• Watch for kinks and/or pinched hoses.</li> <li>• Verify one pressure hose and one return hose.</li> </ul> Test regulator. See Chapter 5 |
| Vacuum leak  | Check for vacuum leaks . . . <ul style="list-style-type: none"> <li>• Between mixer and throttle body</li> <li>• Between throttle body and intake manifold</li> <li>• Between intake manifold and cylinder head</li> </ul>   |

**Related MIL Faults:**

EST faults

ETC Sticking fault

Pre-catalyst adapts error

## Basic Troubleshooting (cont'd.)

**Cuts Out, Misses**

Steady pulsation or jerking that follows engine speed, usually more pronounced as engine load increases, sometimes above 1500 rpm. The exhaust has a steady spitting sound at idle or low speed.

| PRELIMINARY CHECKS  |
|---|
| Perform the visual checks as described at start of "Basic Troubleshooting" chapter. |

| PROBABLE CAUSE              | CORRECTIVE ACTION   |
|-----------------------------|---|
| Fuel system malfunction     | <p>Check fuel system specifically for plugged fuel filter, low pressure.</p> <p>Check for contaminated fuel.</p> <p>Check lock off intermittent connection.</p> <p>Check dither valve operation.</p>  |
| Ignition system malfunction | <p>Check for spark on the suspected cylinder(s) using a shop oscilloscope or spark tester or equivalent. If no spark, check for intermittent operation or miss. If there is a spark, remove spark plug(s) in these cylinders and check for cracks, wear, improper gap, burned electrodes, heavy deposits.</p> <p>Check spark plug wires by connecting ohmmeter to ends of each wire in question. If meter reads over 30,000 ohms, replace wire(s).</p> <p>Visually inspect distributor cap, rotor, and wires for moisture, dust, cracks, burns, etc. Spray plug wires with fine water mist to check for shorts.</p> <p>Check engine ground wire for looseness or corrosion.</p> |
| Component malfunction       | <p>Check for electromagnetic interference (EMI). A missing condition can be caused by EMI on the reference circuit. EMI can usually be detected by monitoring engine rpm with Service Tool. A sudden increase in rpm with little change in actual engine rpm indicates EMI is present. If problem exists, check routing of secondary wires and check distributor ground circuit.</p> <p>Check intake and exhaust manifolds for casting flash or gasket leaks.</p>   |
| Engine mechanical           | <p>Perform compression check on questionable cylinders. If compression is low, repair as necessary.</p> <p>Check base engine. Remove rocker covers and check for bent pushrods, worn rocker arms, broken valve springs, worn camshaft lobes, and valve timing.</p> <p>Repair as necessary.</p>  |

**Related MIL Faults:**

EST faults

ETC Sticking fault



## Basic Troubleshooting (cont'd.)

## Poor Fuel Economy / Excessive Fuel Consumption LPG Exhaust Smell

Fuel economy, as measured during normal operation, is noticeably lower than expected. Also, economy is noticeably lower than what it has been in the past. Propane fuel smell near vehicle sets off carbon monoxide sensors.

| PRELIMINARY CHECKS  |
|---|
| Perform the visual checks as described at start of "Basic Troubleshooting" chapter.<br>Verify operator complaint: identify operating conditions.<br>Check operator's driving habits:<br>Are tires at correct pressure?<br>Are excessively heavy loads being carried?<br>Is acceleration too much, too often?<br>Check air cleaner element (filter) for being dirty or plugged.<br>Visually (physically) check vacuum hoses for splits, kinks, and proper connections. |

| PROBABLE CAUSE  | CORRECTIVE ACTION  |
|---|--|
| Fuel system malfunction                                 | Check for faulty pressure regulator.<br>Check that dither valve duty cycle is < 15%.<br>Check for too high propane pressure at mixer (> 1" positive pressure).<br>Monitor Pre-catalyst O2 sensor with Service Tool.  |
| Cooling system malfunction                              | Check engine coolant level.<br>Check engine thermostat for faulty part (always open) or for wrong heat range.  |
| Ignition system malfunction                             | Check ignition timing.<br>Check for weak ignition and/or spark control.<br>Check spark plugs. Remove spark plugs and check for wet plugs, cracks, wear, improper gap, burned electrodes, or heavy deposits. Repair or replace as necessary.  |
| Component malfunction                                   | Check for exhaust system restriction or leaks.<br>Check induction system and crankcase for air leaks.<br>Check for clogged air filter; clean or replace as required.<br>Check FTV for housing cracks or obstructions; repair or replace as required.<br>Check for vacuum leak. Check system vacuum hoses from regulator to FTV and mixer. Repair or replace as required. |
| Air/fuel mixer malfunction                              | Check mixer.   |
| Pressure regulator malfunction / fuel pressure too high | Test regulator operation and pressure.<br><i>See Chapter 5 Tests and Adjustments.</i>  |
| Engine mechanical                                       | Check compression.<br><i>Refer to Engine Manufacturer's Service Manual.</i>  |

### Related MIL Faults:

Pre-catalyst O2 sensor faults / Low side driver / Dither valve duty cycle  
 EST faults / Fuel adapt faults / Low coolant temperature

## Basic Troubleshooting (cont'd.)

**High Idle Speed**

Engine idles above the range of 750-1000 rpm.

| <b>PRELIMINARY CHECKS</b>   |
|---|
| Perform the visual checks as described at start of "Basic Troubleshooting" chapter. |

| <b>PROBABLE CAUSE</b>                         | <b>CORRECTIVE ACTION</b>   |
|---|--|
| Incorrect idle speed control                  | Check all hoses and gaskets for cracking, kinks, or leaks.<br>Verify that there are no vacuum leaks.<br><i>See Chapter 7 Advanced Diagnostics &amp; Chapter 5 Tests and Adjustments</i>          |
| Throttle sticking                             | Replace throttle.<br><i>See Fault Code 461: ETC_Sticking</i>   |
| Foot pedal sticking or incorrect pedal signal | Check pedal return spring travel for binding.<br>Check APP function with Service Tool.<br>Verify smooth change of APP reading with pedal movement.<br><i>See Chapter 7 Advanced Diagnostics.</i> |
| Engine mechanical                             | Check for vacuum hose leak.<br>Check for PCV malfunction.<br>Check for defective intake gasket.  |

**Related MIL Faults:**

ETC Sticking fault  
Idle adapt out of range  
MAP Sticking fault  
MAP high value

## Basic Troubleshooting (cont'd.)

**Excessive Exhaust Emissions or Odors**

Vehicle has high CO emissions.

NOTE: Excessive odors do not necessarily indicate excessive emissions.

| PRELIMINARY CHECKS   |
|--|
| <p>Verify that no stored codes exist.</p> <p>If emission test shows excessive CO and HC, check items that cause vehicle to run <b>rich</b>.</p> <p>If emission test shows excessive NOx, check items that cause vehicle to run <b>lean</b> or too hot.</p> |

| PROBABLE CAUSE              | CORRECTIVE ACTION   |
|-----------------------------|---|
| Cooling system malfunction  | <p>If the Service tool indicates a very high coolant temperature and the system is running <i>lean</i>:</p> <ul style="list-style-type: none"> <li>• Check engine coolant level.</li> <li>• Check engine thermostat for faulty part (always open) or for wrong heat range.</li> <li>• Check fan operation</li> </ul>  |
| Fuel system malfunction     | <p>If the system is running <i>rich</i>, refer to "Diagnostic Aids" chart on the next page.</p> <p>If the system is running <i>lean</i> refer to "Diagnostic Aids" chart on the next page.</p> <p>Check for properly installed fuel system components.</p> <p>Check fuel pressure.</p>  |
| Ignition system malfunction | <p>Check ignition timing.</p> <p>Check spark plugs, plug wires, and ignition components.</p>  |
| Component malfunction       | <p>Check for vacuum leaks.</p> <p>Check for contamination for catalytic converter (look for the removal of fuel filler neck restrictor).</p> <p>Check for carbon build-up. Remove carbon with quality engine cleaner. Follow instructions on label.</p> <p>Check for plugged PCV valve.</p> <p>Check for stuck or blocked PCV hose.</p> <p>Check for fuel in the crankcase.</p> |

**Related MIL Faults:**

Low side driver  
 Fuel adapt faults  
 EST faults

## Basic Troubleshooting (cont'd.)

**Diagnostic Aids for Rich / Lean Operation**

| SERVICE TOOL ITEM                                     | RICH   | LEAN  |
|---|--|---|
| Pre-catalyst O2 A/ D counts                           | Consistently > 250   | Consistently < 170  |
| Pre-catalyst O2 sensor switching between high and low | Always high ADC  | Always low ADC  |
| Trim valve duty cycle                                 | > 90%  | < 10%   |
| Malfunction codes                                     | <ul style="list-style-type: none"> <li>• Pre-catalyst O2 sensor failed rich</li> <li>• Pre-catalyst O2 sensor high</li> <li>• Fuel adapts</li> </ul> | <ul style="list-style-type: none"> <li>• Pre-catalyst O2 sensor failed lean</li> <li>• Pre-catalyst O2 sensor low</li> <li>• Fuel adapts</li> </ul> |
| Closed loop operation                                 | Stuck in open loop   | Stuck in open loop  |

**RICH OPERATION**

LP (Trim valve duty cycle&gt;90%)

- Inspect hoses from AVV port (port on bottom of mixer) to trim valves and regulator for leaks or blockages, replace as necessary.
- Inspect in-line orifices for blockages (in wye), replace as necessary
- Check trim valves for proper operation, replace as necessary
- Check regulator out pressure, replace if out of spec
- Inspect fuel cone for damage, replace mixer assembly as necessary

**LEAN OPERATION**

LP (Trim valve duty cycle&lt;10%)

- Check for vacuum leaks, replace hoses, o-rings, and gaskets as necessary
- Check balance line for blockage, replace as necessary
- Check vapor hose for restrictions, replace as necessary
- Check trim valves for proper operation, replace as necessary
- Check regulator out pressure, replace if out of spec

## Chart T-1 Restricted Exhaust System Check

Proper diagnosis for a restricted exhaust system is essential before replacement of any components. The following procedures may be used for diagnosis, depending upon engine or tool used.

### CHECK AT PRE-CATALYST OXYGEN (O<sub>2</sub>) SENSOR

1. Carefully remove pre-catalyst oxygen (O<sub>2</sub>) sensor.
2. Install exhaust backpressure tester or equivalent in place of O<sub>2</sub> sensor using Snap-On P/N EEVPV311A kit and YA8661 adapter or Mac tool (see illustration).
3. After completing test described below, be sure to coat threads of O<sub>2</sub> sensor with anti-seize compound prior to re-installation.

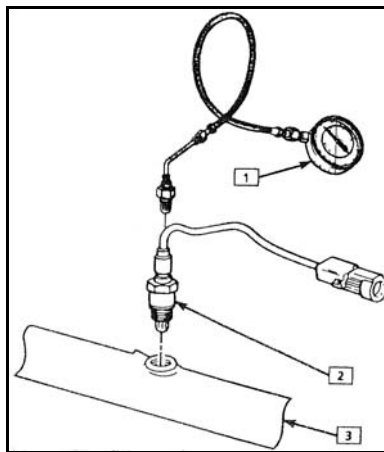

Courtesy of GM 1991 Service Manual  
for Chevrolet Camaro © 1990

#### ILLUSTRATION NOTES

- [1] Backpressure gage
- [2] Pre-catalyst Oxygen (O<sub>2</sub>) sensor
- [3] Exhaust manifold

#### DIAGNOSIS:

1. With the engine idling at normal operating temperature, observe the exhaust system backpressure reading on the gage. Reading should not exceed 1.25 psig (8.61 kPa).
2. Increase engine speed to 2000 rpm and observe gage. Reading should not exceed 3 psig (20.68 kPa).
3. If the backpressure at either speed exceeds specification, a restricted exhaust system is indicated.
4. Inspect the entire exhaust system for a collapsed pipe, heat distress, or possible internal damage, split welds, or cracked pipe.
5. If there are no obvious reasons for the excessive backpressure, the catalytic converter is restricted and should be replaced using current recommended procedures.

## Chapter 7.

# Advanced Diagnostics

MI-07 systems are equipped with built-in fault diagnostics. Detected system faults can be displayed by the Malfunction Indicator Lamp (MIL) as Diagnostic Fault Codes (DFC) or flash codes, and viewed in detail with the use of the Service Tool software. When the ignition key is turned on, the MIL will illuminate and remain on until the engine is started. Once the engine is started, the MIL lamp will go out unless one or more fault conditions are present. If a detected fault condition exists, the fault or faults will be stored in the memory of the small engine control module (SECM). Once an active fault occurs the MIL will illuminate and remain ON. This signals the operator that a fault has been detected by the SECM.

### Reading Diagnostic Fault Codes

All MI-07 fault codes are three-digit codes. When the fault codes are retrieved (displayed) the MIL will flash for each digit with a short pause (0.5 seconds) between digits and a long pause (1.2 seconds) between fault codes. A code 12 is displayed at the end of the code list.

**EXAMPLE:** A code 461 (ETCSticking) has been detected and the engine has shut down and the MIL has remained **ON**. When the codes are displayed the MIL will flash four times (**4**), pause, then flash six times (**6**), pause, then flash one time (**1**) This identifies a four sixty one (**461**), which is the ETCSticking fault. If any additional faults were stored, the SECM would again have a long pause, then display the next fault by flashing each digit. Since no other faults were stored there will be a long pause then one flash (**1**), pause, then two flashes (**2**). This identifies a twelve, signifying the end of the fault list. This list will then repeat.

### Displaying Fault Codes (DFC) from SECM Memory

To enter code display mode you must turn **OFF** the ignition key. Now turn **ON** the key but do not start the engine. As soon as you turn the key to the ON position you must cycle the foot pedal by depressing it to the floor and then fully releasing the pedal (pedal maneuver). You must fully cycle the foot pedal three (**3**) times within five (**5**) seconds to enable the display codes feature of the SECM. Simply turn the key **OFF** to exit display mode. The code list will continue to repeat until the key is turned **OFF**.

### Clearing Fault (DFC) Codes

To clear the stored fault codes from SECM memory you must complete the reset fault pedal maneuver.



#### **CAUTION**

**Once the fault list is cleared it cannot be restored.**

First turn **OFF** the ignition key. Now turn **ON** the key but do not start the engine. As soon as you turn the key to the ON position you must cycle the foot pedal by depressing it to the floor and then fully releasing the pedal (pedal maneuver). You must fully cycle the foot pedal ten (**10**) times within five (**5**) seconds to clear the fault code list of the SECM. Simply turn the key **OFF** to exit the reset mode.

The code list is now clear and the SECM will begin storing new fault codes as they occur.



## Fault Action Descriptions

Each fault detected by the SECM is stored in memory (FIFO) and has a specific action or result that takes place. Listed below are the descriptions of each fault action.

**Engine Shutdown:** The most severe action is an Engine Shutdown. The MIL will light and the engine will immediately shut down, stopping spark and closing the fuel lock-off solenoid valve.

**Delayed Engine Shutdown:** Some faults, such as low oil pressure, will cause the MIL to illuminate for 30 seconds and then shut down the engine.

**Cut Throttle:** The throttle moves to its default position. The engine will run at idle but will not accelerate.

**Cut Fuel:** Fuel flow will be turned off.

**Turn on MIL:** The MIL will light by an active low signal provided by the SECM, indicating a fault condition. May illuminate with no other action or may be combined with other actions, depending on which fault is active.

**Soft Rev Limit / Medium Rev Limit / Hard Rev Limit:** System will follow various sequences to bring engine speed back to acceptable levels.

**Level4 Power Limit / Level3 Power Limit / Level2 Power Limit / Level1 Power Limit:** The maximum engine power output will be limited to one of four possible levels. The engine power is calculated from measured engine parameters (e.g. MAP, rpm, fuel flow, etc).

**Disable Gas O2 Control:** In LPG mode, closed loop correction of air fuel ratio based on the Pre-catalyst O2 sensor is disabled.

## Fault List Definitions

All the analog sensors in the MI-07 system have input sensor range faults. These are the coolant temperature sensor, fuel temperature sensor, throttle position sensors, pedal position sensors, manifold pressure sensor, HEGO sensors, and intake air temperature sensor. Signals to these sensors are converted into digital counts by the SECM. A low/high range sensor fault is normally set when the converted digital counts reach the minimum of 0 or the maximum of 1024 (1024 = 5.0 Vdc with ~ 204 counts per volt).

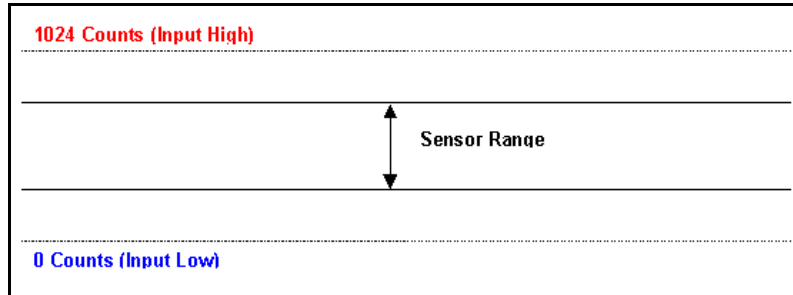

Additionally, the SECM includes software to learn the actual range of the pedal position and throttle position sensors in order to take full advantage of the sensor range. Faults are set if the learned values are outside of the normal expected range of the sensor (e.g. APP1AdaptLoMin).

**Table 1. Fault List Definitions**

| FAULT          | DESCRIPTION  | CODE<br>(MI04 CODE) |
|----------------|--|---------------------|
| APP1AdaptHiMax | Learned full pedal end of APP1 sensor range higher than expected   | 641<br>(64)         |
| APP1AdaptHiMin | Learned full pedal end of APP1 sensor range lower than expected  | 651                 |
| APP1AdaptLoMax | Learned idle end of APP1 sensor range higher than expected   | 661                 |
| APP1AdaptLoMin | Learned idle end of APP1 sensor range lower than expected  | 631<br>(63)         |
| APP1RangeHigh  | APP1 sensor voltage out of range high, normally set if the APP1 signal has shorted to power or the ground for the sensor has opened  | 621<br>(62)         |
| APP1RangeLow   | APP1 sensor voltage out of range low, normally set if the APP1 signal has shorted to ground, circuit has opened or sensor has failed | 611<br>(61)         |
| APP2AdaptHiMax | Learned full pedal end of APP2 sensor range higher than expected   | 642<br>(68)         |

**Table 1. Fault List Definitions (cont'd.)**

| <b>FAULT</b>         | <b>DESCRIPTION</b>  | <b>CODE<br/>(MI04 CODE)</b> |
|----------------------|---|-----------------------------|
| APP2AdaptHiMin       | Learned full pedal end of APP2 sensor range lower than expected   | 652                         |
| APP2AdaptLoMax       | Learned idle end of APP2 sensor range higher than expected  | 662                         |
| APP2AdaptLoMin       | Learned idle end of APP2 sensor range lower than expected   | 632<br>(67)                 |
| APP2RangeHigh        | APP2 sensor voltage out of range high, normally set if the APP2 signal has shorted to power or the ground for the sensor has opened           | 622<br>(66)                 |
| APP2RangeLow         | APP2 sensor voltage out of range low, normally set if the APP2 signal has shorted to ground, circuit has opened or sensor has failed          | 612<br>(65)                 |
| APP_Sensors_Conflict | APP position sensors do not track well, intermittent connections to APP or defective pedal assembly   | 691<br>(69)                 |
| CrankEdgesFault      | No crankshaft signal when engine is known to be rotating, broken crankshaft sensor leads or defective crank sensor                            | 193                         |
| CrankSyncFault       | Loss of synchronization on the crankshaft sensor, normally due to noise on the signal or an intermittent connection on the crankshaft sensor  | 194                         |
| ECTOverTempFault     | Engine Coolant Temperature is High. The sensor has measured an excessive coolant temperature typically due to the engine overheating.         | 161<br>(16)                 |
| ECTRangeHigh         | Engine Coolant Temperature Sensor Input is High. Normally set if coolant sensor wire has been disconnected or circuit has opened to the SECM. | 151<br>(15)                 |

Table 1. Fault List Definitions (cont'd.)

| FAULT              | DESCRIPTION   | CODE<br>(MI04<br>CODE) |
|--------------------|---|------------------------|
| ECTRangeLow        | Engine Coolant Temperature Sensor Input is Low. Normally set if the coolant sensor wire has shorted to chassis ground or the sensor has failed.   | 141<br>(14)            |
| ECT_IR_Fault       | Engine Coolant Temperature not changing as expected   | 171                    |
| EST1_Open          | EST1 output open, possibly open EST1 signal or defective spark module   | 421                    |
| EST1_Short         | EST1 output shorted high or low, EST1 signal shorted to ground or power or defective spark module   | 431<br>(42)            |
| ETCSpringTest      | Electronic Throttle Control Spring Return Test has Failed. The SECM will perform a safety test of the throttle return spring following engine shutdown. If this spring has become weak the throttle will fail the test and set the fault.<br><b>NOTE: Throttle assembly is not a serviceable item and can only be repaired by replacing the DV-EV throttle assembly.</b>                  | 481<br>(28)            |
| ETC_Open_Fault     | Electronic Throttle Control Driver has failed. Normally set if either of the ETC driver signals have opened or become disconnected, electronic throttle or SECM is defective.   | 471                    |
| ETC_Sticking       | Electronic Throttle Control is Sticking. This can occur if the throttle plate (butterfly valve) inside the throttle bore is sticking. The plate sticking can be due to some type of obstruction; a loose throttle plate or worn components shaft bearings.<br><b>NOTE: Throttle assembly is not a serviceable item and can only be repaired by replacing the DV-EV throttle assembly.</b> | 461<br>(26)            |
| FuelSelectConflict | Conflict in fuel select signals, normally set if one or both of the fuel select signals are shorted to ground   | 181                    |
| FuelTempRangeHigh  | Fuel Temperature Sensor Input is High. Normally set if the fuel temperature sensor wire has been disconnected or the circuit has opened to the SECM.  | 932                    |

Table 1. Fault List Definitions (cont'd.)

| FAULT                   | DESCRIPTION   | CODE<br>(MI04 CODE) |
|-------------------------|---|---------------------|
| FuelTempRangeLow        | Fuel Temperature Sensor Input is Low. Normally set if the fuel temperature sensor wire has shorted to chassis ground or the sensor has failed.  | 931                 |
| GasFuelAdaptRangeHi     | In LPG mode, system had to adapt lean more than expected  | 731<br>(73)         |
| GasFuelAdaptRangeLo     | In LPG mode, system had to adapt rich more than expected  | 721<br>(72)         |
| GasO2FailedLean         | Pre-catalyst O2 sensor indicates extended lean operation on LPG   | 751                 |
| GasO2FailedRich         | Pre-catalyst O2 sensor indicates extended rich operation on LPG   | 771<br>(77)         |
| GasO2NotActive          | Pre-catalyst O2 sensor inactive on LPG, open O2 sensor signal or heater leads, defective O2 sensor, or defective FTVs   | 741<br>(74)         |
| GasPostO2FailedRich     | Post-catalyst O2 sensor control on LPG has reached rich limit and sensor still reads to lean. This could be caused by oxygen leak before or just after sensor, catalyst failure, sensor failure, or wiring/relay failure causing the sensor to not be properly heated. If any Pre-O2 sensor faults are set, diagnose these first and after correcting these faults recheck if this fault sets.      | 772                 |
| GasPostO2FailedLean     | Post-catalyst O2 sensor control on LPG has reached lean limit and sensor still reads to rich. This could be caused by catalyst failure, sensor failure, or wiring/relay failure causing the sensor to not be properly heated. If any Pre-O2 sensor faults are set diagnose, these first and after correcting these faults recheck if this fault sets.   | 752                 |
| GasPostO2Inactive       | Post-catalyst O2 sensor control on LPG has sensed the O2 sensor is not responding as expected. If any Pre-O2 sensor faults are set diagnose these first and after correcting these faults recheck if this fault sets. Possible causes for this fault are sensor disconnected, sensor heater failed, sensor element failed, heater relay, or SECM control of heater relay is disconnected or failed. | 742                 |
| Reserved for Future Use |   | 743                 |

Table 1. Fault List Definitions (cont'd.)

| FAULT               | DESCRIPTION  | CODE<br>(MI04<br>CODE) |
|---------------------|--|------------------------|
| HbridgeFault_ETC    | (Electronic Throttle Control Driver has Failed)<br>Indeterminate fault on Hbridge driver for Electronic Throttle Control. Possibly either ETC+ or ETC- driver signals have been shorted to ground  | 491<br>(29)            |
| HardOverspeed       | Engine speed has exceeded the third level (3 of 3) of overspeed protection   | 571<br>(57)            |
| IATRangeHigh        | Intake Air Temperature Sensor Input is High normally set if the IAT temperature sensor wire has been disconnected, the circuit has opened to the SECM, or a short to Vbatt has occurred.           | 381<br>(38)            |
| IATRangeLow         | Intake Air Temperature Sensor Input is Low normally set if the IAT temperature sensor wire has shorted to chassis ground or the sensor has failed.   | 371<br>(37)            |
| IAT_IR_Fault        | Intake Air Temperature not changing as expected  | 391                    |
| LSDFault_Dither1    | Dither Valve 1 Fault, signal has opened or shorted to ground or power or defective dither 1 valve  | 711<br>(71)            |
| LSDFault_Dither2    | Dither Valve 2 Fault, signal has opened or shorted to ground or power or defective dither 2 valve  | 712                    |
| LSDFault_LockOff    | Fuel lock off Valve Fault, signal has opened or shorted to ground or power or defective Fuel lock off valve  | 717                    |
| LSDFault_MIL        | Malfunction Indicator Lamp Fault, signal has opened or shorted to ground or power or defective MIL lamp  | 718                    |
| Reserved            |  | 843                    |
| LowOilPressureFault | Low engine oil pressure  | 521<br>(52)            |
| MAPRangeHigh        | Manifold Absolute Pressure Sensor Input is High, normally set if the TMAP pressure signal wire has become shorted to power, shorted to the IAT signal, the TMAP has failed or the SECM has failed. | 342                    |

**Table 1. Fault List Definitions (cont'd.)**

| <b>FAULT</b>        | <b>DESCRIPTION</b>   | <b>CODE<br/>(MI04<br/>CODE)</b> |
|---------------------|--|---------------------------------|
| MAPRangeLow         | Manifold Absolute Pressure Sensor Input is Low, normally set if the TMAP pressure signal wire has been disconnected or shorted to ground or the circuit has opened to the SECM                     | 332                             |
| MAPTimeRangeHigh    | Manifold Absolute Pressure Sensor Input is High, normally set if the TMAP pressure signal wire has become shorted to power, shorted to the IAT signal, the TMAP has failed or the SECM has failed. | 341<br>(34)                     |
| MAPTimeRangeLow     | Manifold Absolute Pressure Sensor Input is Low, normally set if the TMAP pressure signal wire has been disconnected or shorted to ground or the circuit has opened to the SECM                     | 331<br>(33)                     |
| MAP_IR_HI           | MAP sensor indicates higher pressure than expected   | 351                             |
| MAP_IR_LO           | MAP sensor indicates lower pressure than expected  | 352                             |
| MAP_STICKING        | MAP sensor not changing as expected  | 353                             |
| MediumOverspeed     | Engine speed has exceeded the second level (2 of 3) of overspeed protection  | 572                             |
| O2RangeHigh         | Pre-catalyst O2 sensor voltage out of range high, sensor signal shorted to power   | 921                             |
| O2RangeLow          | Pre-catalyst O2 sensor voltage out of range low, sensor signal shorted to ground   | 911                             |
| O2_PostCatRangeHigh | Post-catalyst O2 sensor voltage out of range high, sensor signal shorted to voltage source (5V or battery)   | 922                             |
| O2_PostCatRangeLow  | Post-catalyst O2 sensor voltage out of range low, sensor signal shorted to ground  | 912                             |
| SensVoltRangeHigh   | Sensor reference voltage XDRP too high   | 561<br>(56)                     |
| SensVoltRangeLow    | Sensor reference voltage XDRP too low  | 551<br>(55)                     |
| ServiceFault1       | Service Interval 1 has been reached  | 991                             |
| ServiceFault2       | Service Interval 2 has been reached  | 992                             |
| ServiceFault3       | Service Interval 3 has been reached  | 993                             |
| ServiceFault4       | Service Interval 4 has been reached—time to replace HEGO sensors   | 994                             |
| ServiceFault5       | Service Interval 5 has been reached—time to replace engine timing belt   | 995                             |
| SoftOverspeed       | Engine speed has exceeded first level (1 of 3) of overspeed protection   | 573                             |
| TPS1AdaptHiMin      | Learned WOT end of TPS1 sensor range lower than expected   | 271                             |
| SysVoltRangeHigh    | System voltage too high  | 541<br>(54)                     |
| SysVoltRangeLow     | System voltage too low   | 531<br>(53)                     |
| TPS1AdaptHiMax      | Learned WOT end of TPS1 sensor range higher than expected  | 251<br>(25)                     |

Table 1. Fault List Definitions (cont'd.)

| FAULT                | DESCRIPTION  | CODE<br>(MI04<br>CODE) |
|----------------------|--|------------------------|
| TPS1AdaptHiMin       | Learned WOT end of TPS1 sensor range lower than expected   | 271                    |
| TPS1AdaptLoMax       | Learned closed throttle end of TPS1 sensor range higher than expected  | 281                    |
| TPS1AdaptLoMin       | Learned closed throttle end of TPS1 sensor range lower than expected   | 241<br>(24)            |
| TPS1RangeHigh        | TPS1 sensor voltage out of range high, normally set if the TPS1 signal has shorted to power or ground for the sensor has opened                                      | 231<br>(23)            |
| TPS1RangeLow         | TPS1 sensor voltage out of range low, normally set if TPS1 signal has shorted to ground, circuit has opened or sensor has failed                                     | 221<br>(22)            |
| TPS2AdaptHiMax       | Learned WOT end of TPS2 sensor range higher than expected  | 252                    |
| TPS2AdaptHiMin       | Learned WOT end of TPS2 sensor range lower than expected   | 272                    |
| TPS2AdaptLoMax       | Learned closed throttle end of TPS2 sensor range higher than expected  | 282                    |
| TPS2AdaptLoMin       | Learned closed throttle end of TPS2 sensor range lower than expected   | 242                    |
| TPS2RangeHigh        | TPS2 sensor voltage out of range high, normally set if the TPS2 signal has shorted to power or ground for the sensor has opened                                      | 232                    |
| TPS2RangeLow         | TPS2 sensor voltage out of range low, normally set if TPS2 signal has shorted to ground, circuit has opened or sensor has failed                                     | 222                    |
| TPS_Sensors_Conflict | TPS sensors differ by more than expected amount.<br><b>NOTE: The TPS is not a serviceable item and can only be repaired by replacing the DV-EV throttle assembly</b> | 291                    |
| TransOilTemp         | Excessive transmission oil temperature   | 933                    |



Table 2. Diagnostic Fault Codes (Flash Codes)

| DFC         | PROBABLE FAULT   | FAULT ACTION *  | CORRECTIVE ACTION FIRST CHECK   |
|-------------|--|---|---|
| 12          | <b>NONE</b><br>Signifies the end of one pass through the fault list  | NONE  | None, used as end of the fault list identification  |
| 141<br>(14) | <b>ECTRangeLow</b><br>Coolant Sensor failure or shorted to GND   | TurnOnMil   | Check ECT sensor connector and wiring for a short to GND<br>SECM (Signal) Pin B15 To ECT Pin 3<br>SECM (Sensor GND) Pin B1 to ECT Pin 1<br>SECM (System GND) Pin A16, B17   |
| 151<br>(15) | <b>ECTRangeHigh</b><br>Coolant sensor disconnected or open circuit   | (1) TurnOnMil<br>(2) DelayedEngine Shutdown<br>(3) CheckEngineLight | Check if ECT sensor connector is disconnected or for an open ECT circuit<br>SECM (Signal) Pin B15 to ECT Pin 3<br>SECM (Sensor GND) Pin B1 to ECT Pin 1   |
| 161<br>(16) | <b>ECTOverTempFault</b><br>Engine coolant temperature is high. The sensor has measured an excessive coolant temperature typically due to the engine overheating. | (1) TurnOnMil<br>(2) DelayedEngine Shutdown<br>(3) CheckEngineLight | Check coolant system for radiator blockage, proper coolant level and for leaks in the system.<br>Possible ECT short to GND, check ECT signal wiring<br>SECM (Signal) Pin B15 to ECT Pin 3<br>SECM (Sensor GND) Pin B1 to ECT Pin 1<br>SECM (System GND) Pin A16, B17<br>Check regulator for coolant leaks |
| 171         | <b>ECT_IR_Fault</b><br>Engine coolant temperature not changing as expected   | None  | Check for coolant system problems, e.g. defective or stuck thermostat   |
| 181         | <b>FuelSelectConflict</b><br>Conflict in fuel select signals, normally set if both of the fuel select signals are shorted to ground                              | TurnOnMil   | Check fuel select switch connection for a short to GND<br>SECM (SIGNAL) Pin A12<br>SECM (SIGNAL) Pin A15<br>SECM (Sensor GND) Pin B1  |
| 193         | <b>CrankEdgesFault</b><br>No crankshaft signal when engine is known to be rotating, broken crankshaft sensor leads or defective crank sensor                     | None  | Check Crankshaft sensor connections<br>SECM (SIGNAL) Pin B5 to Crank sensor Pin 3<br>SECM (Sensor GND) PIN B1 to Crank sensor Pin 2<br>Switched 12V to Crank sensor Pin 1<br>Check for defective Crank sensor   |

(\* ) Fault actions shown are default values specified by the OEM.

Table 2. Diagnostic Fault Codes (Flash Codes) cont'd.

| DFC         | PROBABLE FAULT  | FAULT ACTION* | CORRECTIVE ACTION FIRST CHECK   |
|-------------|---|---------------|---|
| 194         | <b>CrankSyncFault</b><br>Loss of synchronization on the crankshaft sensor, normally due to noise on the signal or an intermittent connection on the crankshaft sensor | None          | Check Crankshaft sensor connections<br>SECM (SIGNAL) Pin B5 to Crank sensor Pin 3<br>SECM (Sensor GND) Pin B1 to Crank sensor Pin 2<br>Switched 12V to Crank sensor Pin 1<br>Check for defective Crank sensor   |
| 221<br>(22) | <b>TPS1RangeLow</b><br>TPS1 sensor voltage out of range low, normally set if the TPS1 signal has shorted to ground, circuit has opened or sensor has failed           | TurnOnMil     | Check throttle connector connection and TPS1 sensor for an open circuit or short to GND<br>SECM Pin B23 (signal) to ETC Pin 6<br>SECM Pin B1 (sensor GND) to ETC Pin 2<br>SECM (system GND) Pin A16, B17  |
| 222         | <b>TPS2RangeLow</b><br>TPS2 sensor voltage out of range low, normally set if the TPS2 signal has shorted to ground, circuit has opened or sensor has failed           | TurnOnMil     | Check throttle connector connection and TPS2 sensor for an open circuit or short to GND<br>SECM Pin B4 (signal) to ETC Pin 5<br>SECM Pin B1 (sensor GND) to ETC Pin 2<br>SECM (system GND) Pin A16, B17   |
| 231<br>(23) | <b>TPS1RangeHigh</b><br>TPS1 sensor voltage out of range high, normally set if the TPS1 signal has shorted to power or the ground for the sensor has opened           | TurnOnMil     | Check throttle connector and TPS1 sensor wiring for a shorted circuit<br>SECM Pin B23 (signal) to ETC Pin 6<br>SECM Pin B1 (sensor GND) to ETC Pin 2  |
| 232         | <b>TPS2RangeHigh</b><br>TPS2 sensor voltage out of range high, normally set if the TPS2 signal has shorted to power or the ground for the sensor has opened           | TurnOnMil     | Check throttle connector and TPS1 sensor wiring for a shorted circuit<br>SECM Pin B4 (signal) to ETC Pin 5<br>SECM pin B1 (sensor GND) to ETC Pin 2   |
| 241<br>(24) | <b>TPS1AdaptLoMin</b><br>Learned closed throttle end of TPS1 sensor range lower than expected   | None          | Check the throttle connector and pins for corrosion.<br>To check the TPS disconnect the throttle connector and measure the resistance from:<br>TPS Pin 2 (GND) to Pin 6 (TPS1 SIGNAL) (0.7 $\Omega$ $\pm$ 30%)<br>TPS Pin 3 (PWR) to Pin 6 (TPS1 SIGNAL) (1.4 $\Omega$ $\pm$ 30%) |

(\*) Fault actions shown are default values specified by the OEM.

Table 2. Diagnostic Fault Codes (Flash Codes) cont'd.

| DFC         | PROBABLE FAULT  | FAULT ACTION *                       | CORRECTIVE ACTION FIRST CHECK   |
|-------------|---|--------------------------------------|---|
| 242         | <b>TPS2AdaptLoMin</b><br>Learned closed throttle end of TPS2 sensor range lower than expected   | None                                 | Check the throttle connector and pins for corrosion.<br>To check the TPS disconnect the throttle connector and measure the resistance from:<br>TPS Pin 2 (GND) to Pin 5 (TPS2 SIGNAL) (1.3K $\Omega$ $\pm$ 30%)<br>TPS PIN 3 (PWR) to PIN 5 (TPS2 SIGNAL) (0.6K $\Omega$ $\pm$ 30%) |
| 251<br>(25) | <b>TPS1AdaptHiMax</b><br>Learned WOT end of TPS1 sensor range higher than expected  | None                                 | N/A   |
| 252         | <b>TPS2AdaptHiMax</b><br>Learned WOT end of TPS2 sensor range higher than expected  | None                                 | N/A   |
| 271         | <b>TPS1AdaptHiMin</b><br>Learned WOT end of TPS1 sensor range lower than expected   | None                                 | N/A   |
| 272         | <b>TPS2AdaptHiMin</b><br>Learned WOT end of TPS2 sensor range lower than expected   | None                                 | N/A   |
| 281         | <b>TPS1AdaptLoMax</b><br>Learned closed throttle end of TPS1 sensor range higher than expected  | None                                 | N/A   |
| 282         | <b>TPS2AdaptLoMax</b><br>Learned closed throttle end of TPS2 sensor range higher than expected  | None                                 | N/A   |
| 291         | <b>TPS_Sensors_Conflict</b><br>TPS sensors differ by more than expected amount<br><b>NOTE: The TPS is not a serviceable item and can only be repaired by replacing the DV-EV throttle assembly.</b> | (1) TurnOnMil<br>(2) Engine Shutdown | Perform checks for DFCs 241 & 242   |

(\*) Fault actions shown are default values specified by the OEM.

Table 2. Diagnostic Fault Codes (Flash Codes) cont'd.

| DFC         | PROBABLE FAULT  | FAULT ACTION *                         | CORRECTIVE ACTION FIRST CHECK  |
|-------------|---|--|--|
| 331<br>(33) | <b>MAPTimeRangeLow</b><br>Manifold Absolute Pressure sensor input is low, normally set if the TMAP pressure signal wire has been disconnected or shorted to ground or the circuit has opened to the SECM                      | None                                   | Check TMAP connector and MAP signal wiring for an open circuit<br>TMAP Pin 4 to SECM Pin B18 (signal)<br>TMAP Pin 1 to SECM Pin B1 (sensor GND)<br>TMAP Pin 3 to SECM Pin B24 (XDRP +5 Vdc)<br>Check the MAP sensor by disconnecting the TMAP connector and measuring at the sensor<br>TMAP Pin 1(GND) to Pin 4 (pressure signal KPA) (2.4k $\Omega$ - 8.2k $\Omega$ )<br>TMAP Pin 3 (power) to Pin 4 (pressure signal KPA) (3.4k $\Omega$ - 8.2k $\Omega$ )   |
| 332         | <b>MAPRangeLow</b><br>Manifold Absolute Pressure sensor input is low, normally set if the TMAP pressure signal wire has been disconnected or shorted to ground or the circuit has opened to the SECM                          | (1)<br>TurnOnMil<br>(2)<br>CutThrottle | Check TMAP connector and MAP signal wiring for an open circuit<br>TMAP Pin 4 to SECM Pin B18 (signal)<br>TMAP Pin 1 to SECM Pin B1 (sensor GND)<br>TMAP Pin 3 to SECM Pin B24 (XDRP +5 Vdc)<br>Check the MAP sensor by disconnecting the TMAP connector and measuring at the sensor:<br>TMAP Pin 1(GND) to Pin 4 (pressure signal KPA) (2.4k $\Omega$ - 8.2k $\Omega$ )<br>TMAP Pin 3 (power) to Pin 4 (pressure signal KPA) (3.4k $\Omega$ - 8.2k $\Omega$ )  |
| 341<br>(34) | <b>MAPTimeRangeHigh</b><br>Manifold Absolute Pressure Sensor Input is High, normally set if the TMAP pressure signal wire has become shorted to power, shorted to the IAT signal, the TMAP has failed or the SECM has failed. | None                                   | Check TMAP connector and MAP signal wiring for a shorted circuit<br>TMAP Pin 4 to SECM Pin B18 (signal)<br>TMAP Pin 1 to SECM Pin B1 (sensor GND)<br>TMAP Pin 3 to SECM Pin B24 (XDRP +5 Vdc)<br>Check the MAP sensor by disconnecting the TMAP connector and measuring at the sensor<br>TMAP Pin 1(GND) to Pin 4 (pressure signal KPA) (2.4k $\Omega$ - 8.2k $\Omega$ )<br>TMAP Pin 3 (power) to Pin 4 (pressure signal KPA) (3.4k $\Omega$ - 8.2k $\Omega$ ) |

Table 2. Diagnostic Fault Codes (Flash Codes) cont'd.

| DFC         | PROBABLE FAULT   | FAULT ACTION *                         | CORRECTIVE ACTION FIRST CHECK   |
|-------------|--|--|---|
| 342         | <b>MAPRangeHigh</b><br>Manifold Absolute Pressure Sensor Input is High, normally set if the TMAP pressure signal wire has become shorted to power, shorted to the IAT signal, the TMAP has failed or the SECM has failed | (1)<br>TurnOnMil<br>(2)<br>CutThrottle | Check TMAP connector and MAP signal wiring for a shorted circuit<br>TMAP Pin 4 to SECM Pin B18 (signal)<br>TMAP Pin 1 to SECM Pin B1 (sensor GND)<br>TMAP Pin 3 to SECM Pin B24 (XDRP +5 Vdc)<br>Check the MAP sensor by disconnecting the TMAP connector and measuring at the sensor:<br>TMAP Pin 1(GND) to Pin 4 (pressure signal KPA) (2.4k $\Omega$ - 8.2k $\Omega$ )<br>TMAP Pin 3 (power) to Pin 4 (pressure signal KPA) (3.4k $\Omega$ - 8.2k $\Omega$ ) |
| 351         | <b>MAP_IR_HI</b><br>MAP sensor indicates higher pressure than expected   | None                                   | Check for vacuum leaks. Check that TMAP sensor is mounted properly. Possible defective TMAP sensor.   |
| 352         | <b>MAP_IR_LO</b><br>MAP sensor indicates lower pressure than expected  | None                                   | Possible defective TMAP sensor.   |
| 353         | <b>MAP_STICKING</b><br>MAP sensor not changing as expected   | None                                   | Check that TMAP sensor is mounted properly. Possible defective TMAP sensor.   |
| 371<br>(37) | <b>IATRangeLow</b><br>Intake Air Temperature Sensor Input is Low normally set if the IAT temperature sensor wire has shorted to chassis ground or the sensor has failed.   | TurnOnMil                              | Check TMAP connector and IAT signal wiring for a shorted circuit<br>TMAP Pin 2 to SECM Pin B12 (signal)<br>TMAP Pin 1 to SECM Pin B1 (sensor GND)<br>To check the IAT sensor of the TMAP disconnect the TMAP connector and measure the IAT resistance<br>Resistance is approx 2400 ohms at room temperature.  |
| 381<br>(38) | <b>IATRangeHigh</b><br>Intake Air Temperature Sensor Input is High normally set if the IAT temperature sensor wire has been disconnected or the circuit has opened to the SECM.  | TurnOnMil                              | Check TMAP connector and IAT signal wiring for a shorted circuit<br>TMAP Pin 2 to SECM Pin B12 (signal)<br>TMAP Pin 1 to SECM Pin B1 (sensor GND)<br>To check the IAT sensor of the TMAP disconnect the TMAP connector and measure the IAT resistance<br>Resistance is approx 2400 ohms at room temperature.  |
| 391         | <b>IAT_IR_Fault</b><br>Intake Air Temperature not changing as expected   | None                                   | Check connections to TMAP sensor. Check that TMAP sensor is properly mounted to manifold.   |

(\*) Fault actions shown are default values specified by the OEM.

Table 2. Diagnostic Fault Codes (Flash Codes) cont'd.

| DFC         | PROBABLE FAULT  | FAULT ACTION *   | CORRECTIVE ACTION FIRST CHECK   |
|-------------|---|--|---|
| 421         | <b>EST1_Open</b><br>EST1 output open, possibly open EST1 signal or defective spark module   | TurnOnMil  | Check coil driver wiring and connector for open circuit<br>SECM Pin A9 (EST1) to OEM ignition system. See application note.<br>Verify GND on ignition module Pin A (of both connectors)<br>Verify +12 Vdc on ignition module Pin B (of both connectors)<br>Refer to application manual for specific engine details.   |
| 431         | <b>EST1_Short</b><br>EST1 output shorted high or low, EST1 signal shorted to ground or power or defective spark module  | TurnOnMil  | Check coil driver wiring and connector for shorts<br>SECM Pin A9 (EST1) to ignition module Pin D (4-pin connector)<br>Verify GND on ignition module Pin A (of both connectors)<br>Verify +12 Vdc on ignition module Pin B (of both connectors)<br>Refer to application manual for specific engine details.  |
| 461<br>(26) | <b>ETC_Sticking</b><br>Electronic Throttle Control is sticking. This can occur if the throttle plate (butterfly valve) inside the throttle bore is sticking. The plate sticking can be due to some type of obstruction, a loose throttle plate, or worn components shaft bearings.<br><b>NOTE: The throttle assembly is not a serviceable item and can only be repaired by replacing the DV-EV throttle assembly.</b> | (1) TurnOnMil<br>(2) EngineShutdown<br>(3) CutThrottle | Check for debris or obstructions inside the throttle body <ul style="list-style-type: none"> <li>Perform the throttle test using the Service Tool and re-check for fault</li> <li>Check throttle-plate shaft for bearing wear</li> </ul> Check the ETC driver wiring for an open circuit<br>SECM Pin A17 to ETC + Pin 1<br>SECM Pin A18 to ETC - Pin 4<br>Check the ETC internal motor drive by disconnecting the throttle connector and measuring the motor drive resistance at the throttle<br>TPS Pin 1 (+DRIVER) to Pin 4 (-DRIVER) ~3.0-4.0Ω |
| 471         | <b>ETC_Open_Fault</b><br>Electronic Throttle Control Driver has failed, normally set if either of the ETC driver signals have opened or become disconnected, electronic throttle or SECM is defective.  | None   | Check the ETC driver wiring for an open circuit<br>SECM Pin A17 to ETC + Pin 1<br>SECM Pin A18 to ETC - Pin 4<br>Check the ETC internal motor drive by disconnecting the throttle connector and measuring the motor drive resistance at the throttle<br>TPS Pin 1 (+DRIVER) to Pin 4 (-DRIVER) ~3.0-4.0Ω  |

(\*) Fault actions shown are default values specified by the OEM.

Table 2. Diagnostic Fault Codes (Flash Codes) cont'd.

| DFC         | PROBABLE FAULT   | FAULT ACTION *  | CORRECTIVE ACTION FIRST CHECK   |
|-------------|--|---|---|
| 481<br>(28) | <p><b>ETCSpringTest</b><br/>Electronic Throttle Control Spring Return Test has failed. The SECM will perform a safety test of the throttle return spring following engine shutdown. If this spring has become weak the throttle will fail the test and set the fault.</p> <p><b>NOTE: The throttle assembly is not a serviceable item and can only be repaired by replacing the DV-EV throttle assembly.</b></p> | <p>(1) TurnOnMil<br/>(2) EngineShutdown</p>                                   | <p>Perform throttle spring test by cycling the ignition key and re-check for fault</p>  |
| 491<br>(29) | <p><b>HbridgeFault_ETC</b><br/>Electronic Throttle Control Driver has failed. Indeterminate fault on Hbridge driver for electronic throttle control. Possibly either ETC+ or ETC- driver signals have been shorted to ground</p>   | <p>TurnOnMil</p>  | <p>Check ETC driver wiring for a shorted circuit<br/>SECM Pin A17 to ETC + Pin 1<br/>SECM Pin A18 to ETC - Pin 4</p> <ul style="list-style-type: none"> <li>Perform the throttle test using the Service Tool and re-check for fault</li> </ul> <p>Check the ETC internal motor drive by disconnecting the throttle connector and measuring the motor drive resistance at the throttle<br/>TPS Pin 1 (+DRIVER) to Pin 4 (-DRIVER) ~3.0-4.0Ω</p>                            |
| 521<br>(52) | <p><b>LowOilPressureFault</b><br/>Low engine oil pressure</p>  | <p>(1) TurnOnMil<br/>(2) DelayedEngine Shutdown<br/>(3) CheckEngine Light</p> | <p>Check engine oil level<br/>Check electrical connection to the oil pressure switch<br/>SECM Pin B9 to Oil Pressure Switch</p>   |
| 531<br>(53) | <p><b>SysVoltRangeLow</b><br/>System voltage too low</p>   | <p>TurnOnMil</p>  | <p>Check battery voltage</p> <ul style="list-style-type: none"> <li>Perform maintenance check on electrical connections to the battery and chassis ground</li> <li>Check battery voltage during starting and with the engine running to verify charging system and alternator function</li> <li>Measure battery power at SECM with a multimeter (with key on)</li> </ul> <p>SECM Pin A23 (DRVP) to SECM Pin A16 (DRVG)<br/>SECM Pin A23 (DRVP) to SECM Pin B17 (DRVG)</p> |

(\*) Fault actions shown are default values specified by the OEM.



Table 2. Diagnostic Fault Codes (Flash Codes) cont'd.

| DFC         | PROBABLE FAULT   | FAULT ACTION *                      | CORRECTIVE ACTION FIRST CHECK   |
|-------------|--|-------------------------------------|---|
| 541<br>(54) | <b>SysVoltRangeHigh</b><br>System voltage too high   | TurnOnMil                           | <p>Check battery and charging system voltage</p> <ul style="list-style-type: none"> <li>• Check battery voltage during starting and with the engine running</li> <li>• Check voltage regulator, alternator, and charging system</li> <li>• Check battery and wiring for overheating and damage</li> <li>• Measure battery power at SECM with a multimeter (with key on)</li> </ul> <p>SECM Pin A23 (DRVP) to SECM Pin A16 (DRVG)<br/>SECM Pin A23 (DRVP) to SECM Pin B17 (DRVG)</p> |
| 551<br>(55) | <b>SensVoltRangeLow</b><br>Sensor reference voltage XDRP too low                                   | (1) TurnOnMil<br>(2) EngineShutdown | <p>Measure transducer power at the TMAP connector with a multimeter<br/>TMAP Pin 3 XDRP +5 Vdc to TMAP Pin 1 XDRG GND</p> <p>Verify transducer power at the SECM with a multimeter<br/>SECM Pin B24 +5 Vdc to SECM Pin B1 XDRG GND</p> <p>Verify transducer power at ETC with a multimeter<br/>ETC Pin 3 XDRP PWR to ETC Pin 2 XDRG GND</p> <p>Verify transducer power to the foot pedal with a multimeter.</p>   |
| 561<br>(56) | <b>SensVoltRangeHigh</b><br>Sensor reference voltage XDRP too high                                 | (1) TurnOnMil<br>(2) EngineShutdown | <p>Measure transducer power at the TMAP connector with a multimeter<br/>TMAP Pin 3 XDRP +5 Vdc to TMAP Pin 1 XDRG GND</p> <p>Verify transducer power at the SECM with a multimeter<br/>SECM Pin B24 +5 Vdc to SECM Pin B1 XDRG GND</p> <p>Verify transducer power at ETC with a multimeter<br/>ETC Pin 3 XDRP PWR to ETC Pin 2 XDRG GND</p> <p>Verify transducer power to the foot pedal with a multimeter.</p>   |
| 571<br>(57) | <b>HardOverspeed</b><br>Engine speed has exceeded the third level (3 of 3) of overspeed protection | (1) TurnOnMil<br>(2) HardRevLimit   | <p>Usually associated with additional ETC faults</p> <ul style="list-style-type: none"> <li>• Check for ETC Sticking or other ETC faults</li> </ul> <p>Verify if the lift truck was motored down a steep grade</p>  |

(\*) Fault actions shown are default values specified by the OEM.

Table 2. Diagnostic Fault Codes (Flash Codes) cont'd.

| DFC         | PROBABLE FAULT  | FAULT ACTION *                         | CORRECTIVE ACTION FIRST CHECK  |
|-------------|---|--|--|
| 572         | <b>MediumOverspeed</b><br>Engine speed has exceeded the second level (2 of 3) of overspeed protection   | (1) TurnOnMil<br>(2) MediumRevLimit    | Usually associated with additional ETC faults <ul style="list-style-type: none"> <li>Check for ETC Sticking or other ETC faults</li> </ul> Verify if the lift truck was motored down a steep grade |
| 573         | <b>SoftOverspeed</b><br>Engine speed has exceeded the first level (1 of 3) of overspeed protection  | (1) TurnOnMil<br>(2) SoftRevLimit      | Usually associated with additional ETC faults <ul style="list-style-type: none"> <li>Check for ETC Sticking or other ETC faults</li> </ul> Verify if the lift truck was motored down a steep grade |
| 611<br>(61) | <b>APP1RangeLow</b><br>APP1 sensor voltage out of range low, normally set if the APP1 signal has shorted to ground, circuit has opened or sensor has failed | (1) TurnOnMil<br>(2) CheckEngine Light | Check foot pedal connector <ul style="list-style-type: none"> <li>Check APP1 signal at SECM PIN B7</li> </ul>  |
| 612<br>(65) | <b>APP2RangeLow</b><br>APP2 sensor voltage out of range low, normally set if the APP2 signal has shorted to ground, circuit has opened or sensor has failed | TurnOnMil                              | Check foot pedal connector <ul style="list-style-type: none"> <li>Check APP2 signal at SECM PIN B16</li> </ul>   |
| 621<br>(62) | <b>APP1RangeHigh</b><br>APP1 sensor voltage out of range high, normally set if the APP1 signal has shorted to power or the ground for the sensor has opened | 1) TurnOnMil<br>(2) CheckEngine Light  | Check foot pedal connector <ul style="list-style-type: none"> <li>Check APP1 signal at SECM PIN B7</li> </ul>  |
| 622<br>(66) | <b>APP2RangeHigh</b><br>APP2 sensor voltage out of range high, normally set if the APP2 signal has shorted to power or the ground for the sensor has opened | TurnOnMil                              | Check foot pedal connector <ul style="list-style-type: none"> <li>Check APP2 signal at SECM PIN B16</li> </ul>   |
| 631<br>(63) | <b>APP1AdaptLoMin</b><br>Learned idle end of APP1 sensor range lower than expected  | None                                   | Check APP connector and pins for corrosion <ul style="list-style-type: none"> <li>Cycle the pedal several times and check APP1 signal at SECM Pin B7</li> </ul>                                    |
| 632<br>(67) | <b>APP2AdaptLoMin</b><br>Learned idle end of APP2 sensor range lower than expected  | None                                   | Check APP connector and pins for corrosion <ul style="list-style-type: none"> <li>Cycle the pedal several times and check APP2 signal at SECM Pin B16</li> </ul>                                   |
| 641<br>(64) | <b>APP1AdaptHiMax</b><br>Learned full pedal end of APP1 sensor range higher than expected   | None                                   | N/A  |
| 642<br>(68) | <b>APP2AdaptHiMax</b><br>Learned full pedal end of APP2 sensor range higher than expected   | None                                   | N/A  |

(\*) Fault actions shown are default values specified by the OEM.

Table 2. Diagnostic Fault Codes (Flash Codes) cont'd.

| DFC         | PROBABLE FAULT   | FAULT ACTION *                       | CORRECTIVE ACTION FIRST CHECK  |
|-------------|--|--------------------------------------|--|
| 651         | <b>APP1AdaptHiMin</b><br>Learned full pedal end of APP1 sensor range lower than expected   | None                                 | N/A  |
| 652         | <b>APP2AdaptHiMin</b><br>Learned full pedal end of APP2 sensor range lower than expected   | None                                 | N/A  |
| 661         | <b>APP1AdaptLoMax</b><br>Learned idle end of APP1 sensor range higher than expected  | None                                 | N/A  |
| 662         | <b>APP2AdaptLoMax</b><br>Learned idle end of APP2 sensor range higher than expected  | None                                 | N/A  |
| 691<br>(69) | <b>APP_Sensors_Conflict</b><br>APP position sensors do not track well, intermittent connections to APP or defective pedal assembly     | 1) TurnOnMil<br>(2) Level1PowerLimit | Check APP connector and pins for corrosion <ul style="list-style-type: none"> <li>• Cycle the pedal several times and check APP1 signal at SECM Pin B7</li> <li>• Cycle the pedal several times and check APP2 signal at SECM Pin B16</li> </ul>   |
| 711<br>(71) | <b>LSDFault_Dither1</b><br>Dither Valve 1 Fault, signal has opened or shorted to ground or power or defective dither 1 valve           | TurnOnMil                            | Check FTV1 for an open wire or FTV connector being disconnected<br>FTV1 Pin 1 (signal) to SECM Pin A1<br>FTV1 Pin 2 (power) to SECM (DRVP) Pin A23<br>Check FTV1 for an open coil by disconnecting the FTV connector and measuring the resistance ( $\sim 26\Omega \pm 2\Omega$ )                          |
| 712         | <b>LSDFault_Dither2</b><br>Dither Valve 2 Fault, signal has opened or shorted to ground or power or defective dither 2 valve           | TurnOnMil                            | Check FTV1 for an open wire or FTV connector being disconnected or signal shorted to GND<br>FTV2 Pin 1 (signal) to SECM Pin A2<br>FTV2 Pin 2 (power) to SECM (DRVP) Pin A23<br>Check FTV1 for an open coil by disconnecting the FTV connector and measuring the resistance ( $\sim 26\Omega \pm 2\Omega$ ) |
| 714         | <b>LSDFault_CheckEngine</b><br>Check Engine Lamp Fault, signal has opened or shorted to ground or power or defective check engine lamp | None                                 | Check 'Check Engine Lamp' for an open wire or shorted to GND   |

(\*) Fault actions shown are default values specified by the OEM.

Table 2. Diagnostic Fault Codes (Flash Codes) cont'd.

| DFC         | PROBABLE FAULT   | FAULT ACTION *                            | CORRECTIVE ACTION FIRST CHECK   |
|-------------|--|---|---|
| 715         | <b>LSDFault_CrankDisable</b><br>Crank Disable Fault, signal has opened or shorted to ground or power or defective crank disable relay  | None                                      | N/A   |
| 717         | <b>LSDFault_LockOff</b><br>Fuel lock off Valve Fault, signal has opened or shorted to ground or power or defective Fuel lock off valve | TurnOnMil                                 | Check fuel lock off valve for an open wire or connector being disconnected or signal shorted to GND<br>Lockoff Pin B (signal) to SECM Pin A11 Lockoff Pin A (power) to SECM (DRVP) Pin A23<br>Check CSV for an open coil by disconnecting the CSV connector and measuring the resistance ( $\sim 26\Omega \pm 3\Omega$ )  |
| 718         | <b>LSDFault_MIL</b><br>Malfunction Indicator Lamp Fault, signal has opened or shorted to ground or power or defective MIL lamp         | None                                      | Check MIL lamp for an open wire or short to GND.  |
| 721<br>(72) | <b>GasFuelAdaptRangeLo</b><br>In LPG mode, system had to adapt rich more than expected   | TurnOnMil                                 | Check for vacuum leaks.<br>Check fuel trim valves, e.g. leaking valve or hose<br>Check for missing orifice(s).  |
| 731<br>(73) | <b>GasFuelAdaptRangeHi</b><br>In LPG mode, system had to adapt lean more than expected   | TurnOnMil                                 | Check fuel trim valves, e.g. plugged valve or hose.<br>Check for plugged orifice(s).  |
| 741<br>(74) | <b>GasO2NotActive</b><br>Pre-catalyst O2 sensor inactive on LPG, open O2 sensor signal or heater leads, defective O2 sensor            | (1) TurnOnMil<br>(2) DisableGas<br>O2Ctrl | Check that Pre-catalyst O2 sensor connections are OK.<br>O2 (signal) Pin 3 to SECM Pin B13<br>O2 Pin 2 (HEATER GND) to SECM (DRVG GNG) Pins A16, B17<br>O2 Pin 1 (HEATER PWR) to SECM (DRVP + 12V) Pin A23<br>Verify O2 sensor heater circuit is operating by measuring heater resistance<br>( $2.1\Omega \pm 0.4\Omega$ )<br>O2 Pin 2 (HEATER GND) to Pin 1 (HEATER PWR) |

(\*) Fault actions shown are default values specified by the OEM.

Table 2. Diagnostic Fault Codes (Flash Codes) cont'd.

| DFC         | PROBABLE FAULT  | FAULT ACTION *                              | CORRECTIVE ACTION FIRST CHECK   |
|-------------|---|---|---|
| 742         | <b>GasPostO2NotActive</b><br>Post-catalyst O2 sensor inactive on LPG, open O2 sensor signal or heater leads, defective O2 sensor. | (1) TurnOnMil<br>(2) DisableGas Post O2Ctrl | Check that Post-catalyst O2 sensor connections are OK.<br>O2 (signal) Pin 3 to SECM Pin B19<br>O2 Pin 2 (HEATER GND) to SECM (DRVG GNG) Pins A16, B17<br>O2 Pin 1 (HEATER PWR) to Post O2 Heater Relay. Relay pin 87. This relay turns on only after engine has been running for some time and SECM has calculated that water condensation in exhaust has been removed by exhaust heat. Post O2 Heater Relay has SECM (DRVP + 12V) applied to the relay coil power. The relay coil ground is controlled by SECM Pin A20 to activate the relay to flow current through the post O2 heater.<br>Verify O2 sensor heater circuit is operating by measuring heater resistance ( $2.1\Omega \pm 0.4\Omega$ )<br>O2 Pin 2 (HEATER GND) to Pin 1 (HEATER PWR) |
| 743         | Reserved  |   |   |
| 751         | <b>GasO2FailedLean</b><br>Pre-catalyst O2 sensor indicates extended lean operation on LPG   | (1) TurnOnMil<br>(2) DisableGas O2Ctrl      | Check for vacuum leaks.<br>Check fuel trim valves, e.g. leaking valve or hose.<br>Check for missing orifice(s).   |
| 752         | <b>GasPostO2FailedLean</b><br>Pre-catalyst O2 sensor indicates extended lean operation on LPG                                     | (1) TurnOnMil<br>(2) DisableGas Post O2Ctrl | Correct other faults that may contribute to 752 (e.g. faults pertaining to fuel trim valves, Pre-Cat O2, Post Cat O2 sensor)<br>Check for vacuum leaks<br>Check for leaks in exhaust, catalytic converter, HEGO sensors; repair leaks.<br>Check all sensor connections (see fault 742 corrective actions).  |
| 771<br>(77) | <b>GasO2FailedRich</b><br>Pre-catalyst O2 sensor indicates extended rich operation on LPG   | (1) TurnOnMil<br>(2) DisableGas O2Ctrl      | Check fuel trim valves, e.g. plugged valve or hose.<br>Check for plugged orifice(s).  |

(\*) Fault actions shown are default values specified by the OEM.

Table 2. Diagnostic Fault Codes (Flash Codes) cont'd.

| DFC | PROBABLE FAULT  | FAULT ACTION *   | CORRECTIVE ACTION FIRST CHECK   |
|-----|---|--|---|
| 772 | <b>GasPostO2FailedRich</b><br>Pre-catalyst O2 sensor indicates extended rich operation on LPG                   | (1) TurnOnMil<br>(2) DisableGas<br>PostO2Ctrl            | Correct other faults that may contribute to 772 (e.g. faults pertaining to FTVs, Pre-Cat O2, Post Cat O2 sensor)<br>Look for leaks in exhaust, catalytic converter, HEGO sensors; repair leaks.<br>Check all sensor connections (see fault 742 corrective actions). |
| 843 | Reserved  |  |   |
| 911 | <b>O2RangeLow</b><br>Pre-catalyst O2 sensor voltage out of range low, sensor signal shorted to ground           | (1) TurnOnMil<br>(2) DisableGas<br>O2Ctrl                | Check if O2 sensor installed before the catalyst is shorted to GND or sensor GND.<br>O2 (signal) Pin 3 to SECM Pin B13<br>SECM (DRVG GND) Pins A16, B17<br>SECM (XDRG sensor GND) Pin B1  |
| 912 | <b>O2_PostCatRangeLow</b><br>Post-catalyst O2 sensor voltage out of range low, sensor signal shorted to ground  | (1) TurnOnMil<br>(2) Disable<br>LPG Post-catalyst O2Ctrl | Check if O2 installed after the catalyst sensor is shorted to GND or sensor GND.<br>O2 (signal) Pin 3 to SECM Pin B19<br>Possible sources: SECM (DRVG GND) Pins A16, B17 and SECM (XDRG sensor GND) Pin B1  |
| 921 | <b>O2RangeHigh</b><br>Pre-catalyst O2 sensor voltage out of range high, sensor signal shorted to power          | (1) TurnOnMil<br>(2) DisableGas<br>O2Ctrl                | Check if O2 sensor installed before catalyst is shorted to +5Vdc or battery.<br>O2 (signal) Pin 3 to SECM Pin B13<br>SECM (XDRP + 5V) Pin B24<br>SECM (DRVP + 12V) Pin A23  |
| 922 | <b>O2_PostCatRangeHigh</b><br>Post-catalyst O2 sensor voltage out of range low, sensor signal shorted to ground | (1) TurnOnMil<br>(2) Disable<br>LPG Post-catalyst O2Ctrl | Check if O2 sensor installed after catalyst is shorted to +5Vdc or battery.<br>O2 (signal) Pin 3 to SECM Pin B19<br>Possible voltage sources: SECM (XDRP + 5V) Pin B24 and SECM (DRVP + 12V) Pin A23  |

(\*) Fault actions shown are default values specified by the OEM.

Table 2. Diagnostic Fault Codes (Flash Codes) cont'd.

| DFC | PROBABLE FAULT  | FAULT ACTION *                              | CORRECTIVE ACTION FIRST CHECK   |
|-----|---|---|---|
| 931 | <b>FuelTempRangeLow</b><br>Fuel Temperature Sensor Input is Low normally set if the fuel temperature sensor wire has shorted to chassis ground or the sensor has failed.        | TurnOnMil                                   | Check fuel temp sensor connector and wiring for a short to GND<br>SECM (signal) Pin B14 to FTS Pin 1<br>SECM (sensor GND) Pin B1 to FTS Pin 2<br>SECM (system GND) Pin A16, B17 |
| 932 | <b>FuelTempRangeHigh</b><br>Fuel Temperature Sensor Input is High normally set if the fuel temperature sensor wire has been disconnected or the circuit has opened to the SECM. | TurnOnMil                                   | Check if fuel temp sensor connector is disconnected or for an open FTS circuit<br>SECM (signal) Pin B14 to FTS Pin 1<br>SECM (sensor GND) Pin B1 to FTS Pin 2                   |
| 933 | <b>TransOilTemp</b><br>Excessive transmission oil temperature   | (1) TurnOnMil<br>(2) Delayed EngineShutdown | Refer to drivetrain manufacturer's transmission service procedures.   |
| 991 | <b>ServiceFault1</b><br>Service Interval 1 has been reached   | None  | Perform service procedure related to Service Interval 1 (determined by OEM)   |
| 992 | <b>ServiceFault2</b><br>Service Interval 2 has been reached   | None  | Perform service procedure related to Service Interval 2 (determined by OEM)   |
| 993 | <b>ServiceFault3</b><br>Service Interval 3 has been reached   | None  | Perform service procedure related to Service Interval 3 (determined by OEM)   |
| 994 | <b>ServiceFault4</b><br>Service Interval 4 has been reached—replace HEGO sensors  | TurnOnMil                                   | Replace Pre-catalyst HEGO sensor<br>Replace Post-catlyst HEGO sensor  |
| 995 | <b>ServiceFault5</b><br>Service Interval 5 has been reached—replace timing belt   | TurnOnMil                                   | Replace engine timing belt  |

(\*) Fault actions shown are default values specified by the OEM.

## Chapter 9. Parts Description

### LP Fuel System Components for 4.3L GM Engines

The chart below lists the MI-07 components required for a 4.3L GM engine operating on LP fuel. Components shown with part numbers are supplied by Woodward as part of the MI-07 system package. Components shown with a dot (•) are supplied by customer.

| PART NO.  | DESCRIPTION                         | QTY |
|-----------|-------------------------------------|-----|
| 1751-6068 | Engine Control Module (SECM 48-pin) | 1   |
| •         | Crankshaft Position Sensor          | 1   |
| 1689-1033 | TMAP Sensor                         | 1   |
| 1689-1081 | Fuel Temperature Sensor             | 1   |
| •         | Transmission Oil Temperature Switch | 1   |
| •         | Oxygen Sensors                      | 2   |
| •         | Coolant Sensor                      | 1   |
| •         | Engine Oil Pressure Switch          | 1   |
| 1309-6019 | Fuel Trim Valve                     | 2   |
| •         | Ignition Coils                      | 1   |
| 1311-1011 | Fuel Lock Off Solenoid              | 1   |
| 5233-1018 | Regulator                           | 1   |
| 8062-1036 | CA100 Mixer                         | 1   |
| 6945-5001 | Throttle-DV-E5 40mm                 | 1   |



## CA100 Mixer

Refer to **Figure 37** exploded view on facing page.

### Parts List CA100 Mixer

| REF NO. | DESCRIPTION  | QTY |
|---------|--|-----|
| 1       | Torx Screws (T-25) #10-24 x 5/8"   | 4   |
| 2       | Lockwashers (T-210) #10 SST  | 4   |
| 3       | Mixer Cover  | 1   |
| 4       | Mixer Spring   | 1   |
| 5       | Diaphragm  | 1   |
| 6       | Air Valve Assembly   | 1   |
| 7       | Gas Valve Cone (part of air valve assembly)  | 1   |
| 8       | Mixer Body   | 1   |
| 9       | Expansion Plug Cap $\varnothing$ 1/2" x 1/16" thick ( $\varnothing$ 12.7mm x 27mm) | 1   |
| 10      | Fuel Inlet   | 1   |
| 11      | Air Horn Gasket  | 1   |
| 12      | Air Horn Adapter 2-1/16" (52.37mm)   | 1   |
| 13      | Fillister Head Screws SEMS Lockwasher 10-24 UNC x 5/8"                             | 4   |
| 14      | Throttle Body Gasket   | 1   |
| 15      | Fillister Head Screws SEMS Split Lockwasher #12-24 x 5/8"                          | 4   |

Exploded View CA100 Mixer

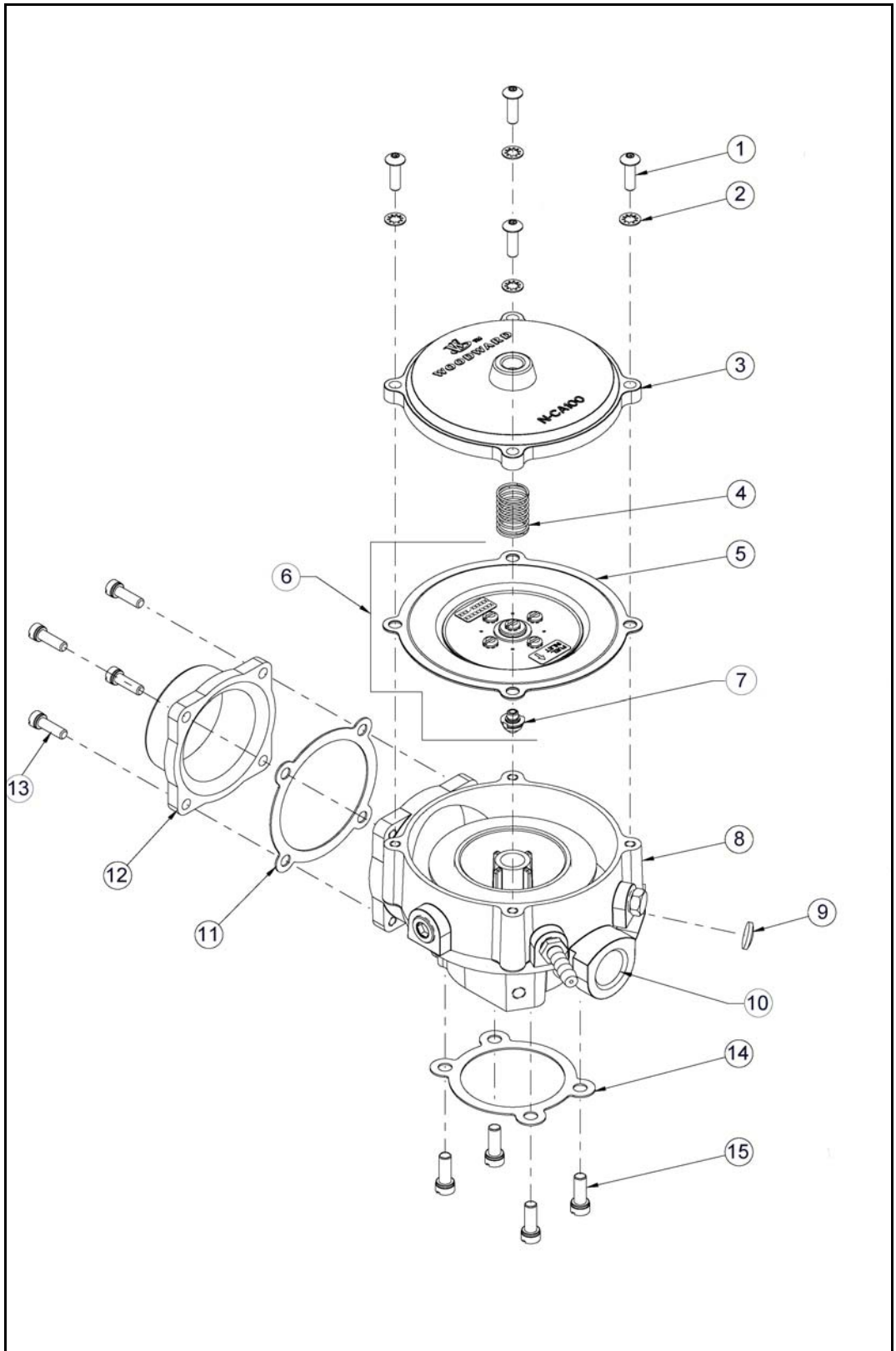

DWG NO 9097-2008 Rev 2

Figure 37. CA100 Mixer Exploded View

## N-2007 Regulator

Refer to **Figure 38** exploded view on facing page.

### Parts List N-2007 Regulator

| REF NO. | DESCRIPTION  | QTY |
|---------|--|-----|
| 1       | N-2007 Body  | 1   |
| 2       | Diaphragm, Primary Assembly  | 1   |
| 3       | Springs, Primary Assembly  | 2   |
| 4       | Cover, Primary Assembly  | 1   |
| 5       | Spring, Secondary Seat, Red  | 1   |
| 6       | Dowel Pin $\emptyset$ 0.094" x 1" L ( $\emptyset$ 2.39mm x 25.4mm L)<br>Hardened Steel | 1   |
| 7       | Diaphragm, Secondary Assembly  | 1   |
| 8       | Lever, Secondary   | 1   |
| 9       | Seat, Secondary  | 1   |
| 10      | Valve Primary  | 1   |
| 11      | Fillister Head Screws SEMS Split Lockwasher #12-24 x 5/8"                              | 6   |
| 12      | Pan Head Screw SEMS Ext. Tooth Lockwasher #12-24 x 1/4"                                | 1   |
| 13      | Body Gasket  | 1   |
| 14      | Back Plate   | 1   |
| 15      | O-ring, Size 107 GLT Viton <sup>®</sup>  | 1   |
| 16      | Bottom Plate Gasket  | 1   |
| 17      | Plate Cover  | 1   |
| 18      | Fillister Head Screws SEMS Split Lockwasher #12-24 x 1-3/8"                            | 6   |
| 19      | Hex Head Screws SEMS Split Lockwasher 1/4-20 x 5/8"                                    | 4   |
| 20      | Plug, Socket Head Pipe (T-086)   | 1   |
| 21      | Cover, Secondary Diaphragm   | 1   |
| 22      | Lockwasher, Int. Tooth (T-210) #8 SST  | 6   |
| 23      | Torx Screws (T-15) #8-32 x 5/8"  | 6   |

### Exploded View N-2007 Regulator

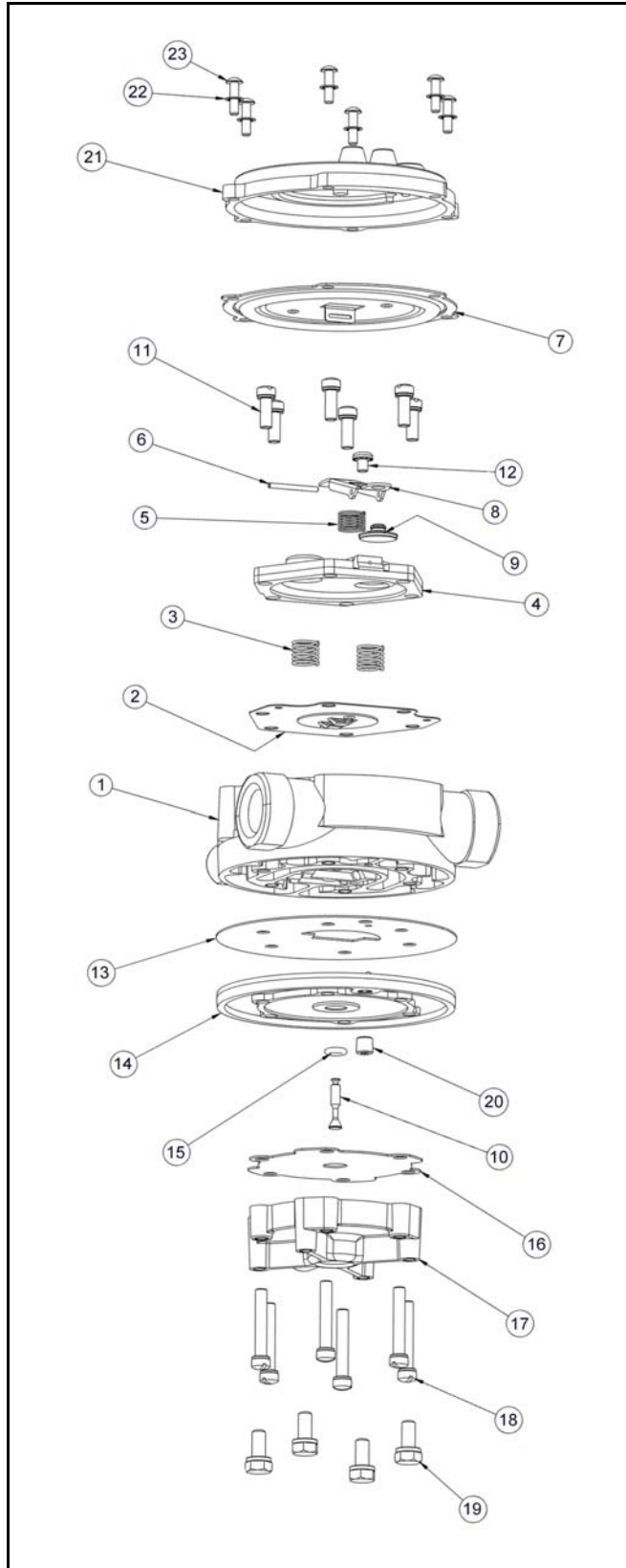

DWG NO 1326-4039 Rev 100

Figure 38. N-2007 Regulator Exploded View

## Appendix

### LPG & LPG Fuel Tanks

Liquefied petroleum gas (LPG) consists mainly of propane, propylene, butane, and butylenes in various mixtures. LPG is produced as a by-product of natural gas processing or it can be obtained from crude oil as part of the oil refining process. LPG, like gasoline, is a compound of hydrogen and carbon, commonly called hydrocarbons.

In its natural state, propane is colorless and odorless; an odorant (ethyl mercaptan) is added to the fuel so its presence can be detected. There are currently three grades of propane available in the United States. A propane grade designation of HD5 (not exceeding 5% propylene), is used for internal combustion engines while much higher levels of propylene (HD10) are used as commercial grade propane along with a commercial propane /butane mixture.

#### APPROXIMATE COMPOSITION OF HD5 PROPANE BY VOLUME

| Propane (C <sub>3</sub> H <sub>8</sub> ) | Propylene | Butane (C <sub>4</sub> H <sub>10</sub> ) | Iso-Butane | Methane (CH <sub>4</sub> ) | TOTAL |
|--|-----------|--|------------|----------------------------|-------|
| 90.0% min.                               | 5% max.   | 2.0%                                     | 1.5%       | 1.5%                       | 100%  |

An advantage of LPG is the ability to safely store and transport the product in the liquid state. In the liquid state propane is approximately 270 times as dense as it is in a gaseous form. By pressurizing a container of LPG we can effectively raise the boiling point above -44° F (-42° C), keeping the propane in liquid form. The point at which the liquid becomes a gas (boiling point) depends on the amount of pressure applied to the container.

This process operates similarly to an engine coolant system where water is kept from boiling by pressurizing the system and adding a mixture of glycol. For example, water at normal atmospheric pressure will boil at 212° F (100° C). If an engine's operating temperature is approximately 230° F (110° C) then the water in an open un-pressurized cooling system would simply boil off into steam, eventually leaving the cooling system empty and overheating the engine. If we install a 10-psig cap on the radiator, pressurizing the cooling system to 10 psig, the boiling point of the water increases to 242° F (117° C), which will cause the water to remain in liquid state at the engine's operating temperature.

The same principle is applied to LPG in a container, commonly referred to as an LPG tank or cylinder. Typically an LPG tank is not filled over 80% capacity to allow for a 20% vapor expansion space. Outside air temperature affects an LPG tank and must be considered when using an LPG system. **Figure A1** shows the relationship between pressure and temperature in a LPG tank at a steady state condition.

## LPG Tank Pressure VS Temperature

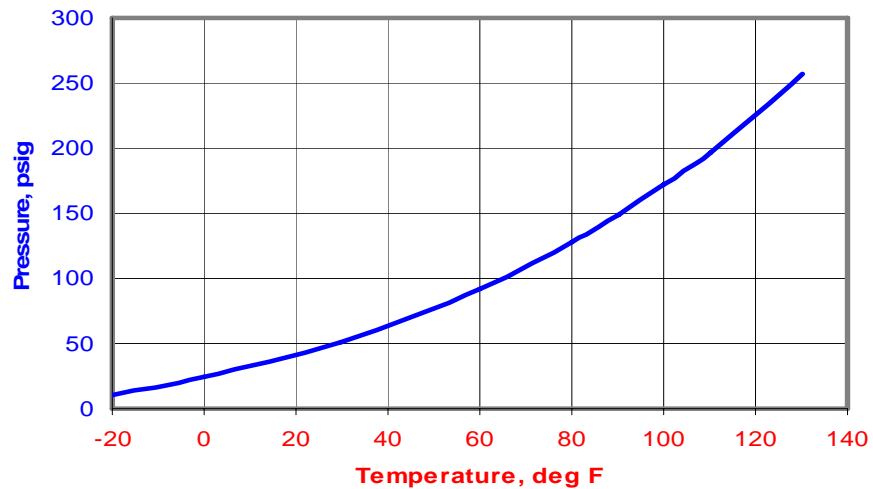
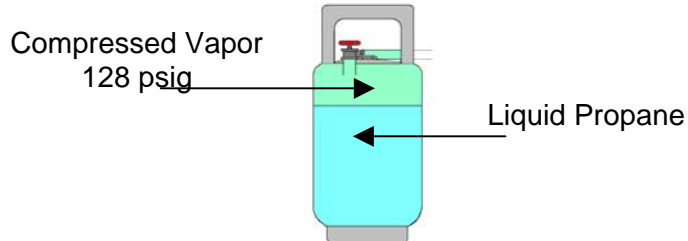

Figure A1. LPG Tank Pressure vs Temperature

With 128 psig vapor pressure acting against the liquid propane, the boiling point has been raised to slightly more than 80° F (27° C).

**NOTE**

Vapor pressure inside an LPG tank depends on the propane temperature, not the amount of liquid inside the tank. A tank that is 3/4 full of liquid propane at 80°F (27°C) will contain the same vapor pressure as a tank that is only 1/4 full of liquid propane.

LPG's relative ease of vaporization makes it an excellent fuel for low-rpm engines on start-and-stop operations. The more readily a fuel vaporizes, the more complete combustion will be. Because propane has a low boiling point (-44° F [-42° C]), and is a low carbon fuel, engine life can be extended due to less cylinder wall wash down and little, if any, carbon build up.

## LPG Fuel Tanks

The two styles of LPG storage containers available for industrial use and lift truck applications are portable universal cylinders and permanently mounted tanks. Portable universal cylinders are used primarily for off-highway vehicles and are constructed in accordance with the DOT-TC (United States Department of Transport – Transport Canada). The cylinders are referred to as universal because they can be mounted in either a vertical or horizontal position (**Figure A2**).



**Figure A2. Portable Universal Cylinder**



### NOTE

A 375-psig relief valve is used on a DOT forklift tank. The relief valve must be replaced with a new valve after the first 12 years and every 10 years thereafter.

The tank must be discarded if the collar is damaged to the point that it can no longer protect the valves. It must also be replaced if the foot ring is bent to the point where the tank will not stand or is easily knocked over.

## Installing LPG Fuel Tanks

When installing a tank on a lift truck, the tank must be within the outline of the vehicle to prevent damage to the valves when maneuvering in tight spaces. Horizontal tanks must be installed on the saddle that contains an alignment pin, which matches the hole in the collar of the tank. When the pin is in the hole, the liquid withdrawal tube is positioned to the bottom of the tank. A common problem is that often these guide-pins are broken off, allowing the tank to be mounted in any position. This creates two problems: (1) Exposure of the liquid withdrawal tube to the vapor space may give a false indication that the tank is empty, when actually it is not. (2). The safety relief valve may be immersed in liquid fuel. If for any reason the valve has to vent, venting liquid can cause a serious safety problem.



### CAUTION

Exchange empty tank with a pre-filled replacement tank. Wear safety glasses and gloves when exchanging a tank.

## LPG Fuel Tank Components

1. Fuel Gauge
2. 80% Stop Bleeder
3. Pressure Relief Valve
4. Service Valve (Tank end male coupling)
5. Filler Valve
6. Alignment Pin
7. Vapor Withdrawal Tube (used only with vapor withdrawal)
8. 80% Limiter Tube
9. Liquid Withdrawal Tube

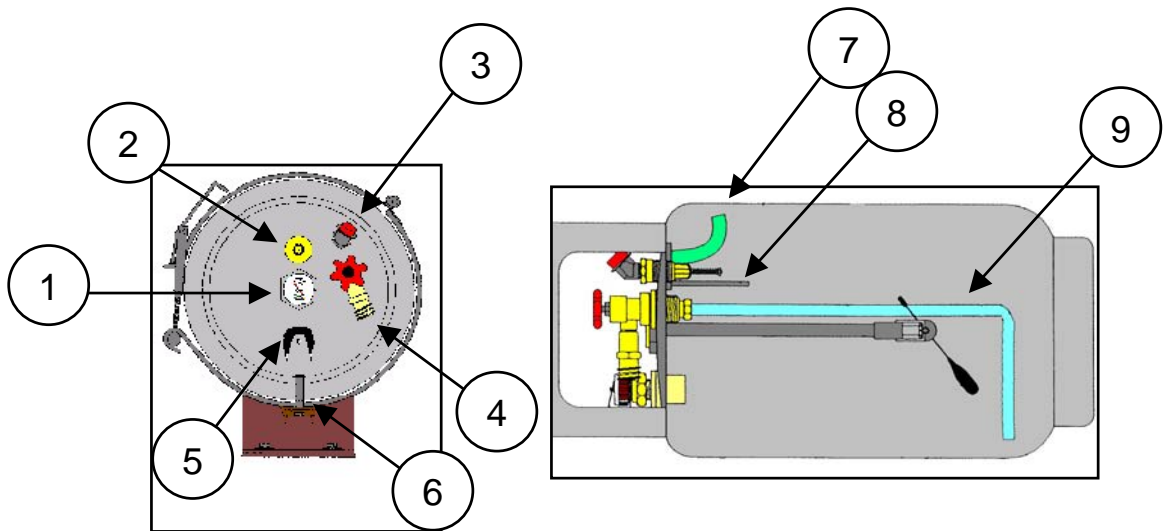

Figure A3. LPG Fuel Tank Components

## Fuel Gauge

In **Figure A3** a visual fuel gauge is used to show the fuel level in the tank. A mechanical float mechanism detects the liquid propane level. A magnet on the end of the float shaft moves a magnetic pointer in the fuel gauge. Some units have an electronic sending unit using a variable resistor, installed in place of a gauge for remote monitoring of the fuel level. The gauge may be changed with fuel in the tank. **DO NOT REMOVE THE FOUR LARGE FLANGE BOLTS THAT RETAIN THE FLOAT ASSEMBLY WHEN FUEL IS IN THE TANK!**



### WARNING

It is not a legal practice to fill the tank through the liquid contents gauge.

In some applications a fixed tube fuel indicator is used in place of a float mechanism. A fixed tube indicator does not use a gauge and only indicates when the LPG tank is 80% full. The fixed tube indicator is simply a normally closed valve that is opened during refueling by the fueling attendant. When opened



during refueling and the tanks LPG level is below 80%, a small amount of vapor will exit the valve. When the LPG tank level reaches 80% liquid propane will begin exiting the valve in the form of a white mist (Always wear the appropriate protective apparel when refueling LPG cylinders). In order for this type of gauge to be accurate, the tank must be positioned properly. When full (80% LPG) the valve is closed by turning the knurled knob clockwise. Typically a warning label surrounds the fixed tube gauge which reads **STOP FILLING WHEN LIQUID APPEARS**.

## Pressure Relief Valve

A pressure relief valve is installed for safety purposes on all LPG tanks. Portable fuel tank safety pressure relief valves are a normally closed spring-loaded valve and are calibrated to open at 375 psig tank pressure. This will allow propane vapor to escape to the atmosphere. When tank pressure drops below the preset value the valve closes.

## Service Valve

The service valve is a manually operated valve using a small hand wheel to open and close the fuel supply to the service line (fuel supply line). The service valve installs directly into the tank and has two main categories, liquid and vapor service valves. Liquid service valves used on portable LPG tanks use a 3/8" NPT) male pipe thread on the service valve outlet for attachment of a quick disconnect coupler.

An excess flow valve is built into the inlet side of the service valve as a safety device in case of an accidental opening of the service line or damage to the service valve itself. The excess flow valve shuts off the flow of liquid propane if the flow rate of the liquid propane exceeds the maximum flow rate specified by the manufacturer.

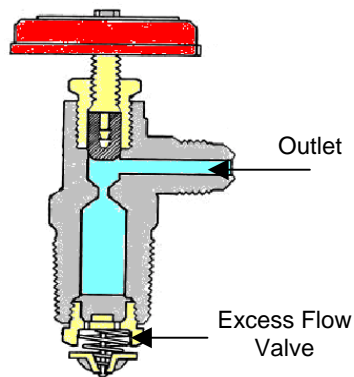

Figure A4. Service Valve

**CAUTION**

The service valve should be completely open when the tank is in use. If the valve is partly open, the vehicle may not get enough fuel to operate efficiently.

In addition to possibly starving the engine for fuel, a partly open valve may restrict the flow enough to prevent the excess flow valve from closing in the event of a ruptured fuel line.

Most liquid service valves have an internal hydrostatic relief valve and are usually labeled "**LIQUID WITH INTERNAL RELIEF.**" The hydrostatic relief valve protects the fuel service line between the tank and the lock off from over pressurization. The internal hydrostatic relief valve has a minimum opening pressure of 375 psig and a maximum pressure of 500 psig. These relief valves have an advantage over external relief valves because the propane is returned to the tank in the event of an over pressurization instead of venting the propane to the atmosphere.

## Quick Disconnect Coupling

The liquid withdrawal or service valve on a DOT tank has male threads and accepts the female portion of a quick disconnect coupling (**Figure A5**). The female portion is adapted to the liquid hose going to the fuel system. Both halves are equipped with 100% shutoffs, which open when coupled together to allow fuel flow. The coupler has two seals. One is an o-ring and the other is a flat washer. The o-ring prevents leakage from the shaft on the other coupling and the flat washer seals when the coupler is fully connected.

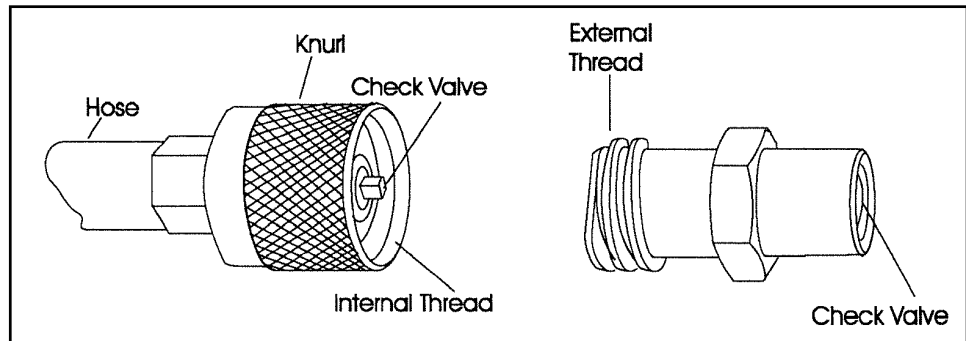

**Figure A5. Quick Disconnect Coupling**



### NOTE

The flat seal and/or the o-ring will sometimes pop off when disconnecting and slide up the shaft of the mating connector, causing the valve not to open when fully mated. Remove the extra washer or o-ring from the shaft and reconnect the coupling.

## Filler Valve

The liquid filler valve (**Figure A6**) has a male thread to receive a fuel nozzle and typically has a plastic or brass screw on cap that is retained with a small chain or plastic band to keep debris out of the filler valve. The filler valve is a one-way flow device that uses two check valves to allow fuel to enter the tank but prevent it from exiting. Both check valves are backpressure type check valves, designed so that backpressure from the tank assists the check valves own spring pressure to close the valve. The first valve uses a neoprene on metal seal and the second valve uses a metal on metal seal.

A weakness ring is machined into the filler valve just above the check valves and will allow the filler valve to shear off in case of an accident. The valve will break or shear off above the check valves so that the tank will be sealed and no liquid propane can escape.

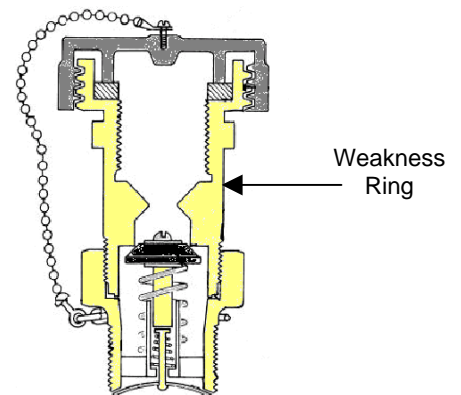

**Figure A6. Liquid Filler Valve**



## Abbreviations

|                  |  |
|------------------|--|
| <b>ACFM</b>      | Actual cubic feet per minute at the specified suction conditions   |
| <b>AFR</b>       | Air fuel ratio   |
| <b>BHP</b>       | Brake horsepower   |
| <b>Bi-Fuel</b>   | Able to operate on either of two fuels   |
| <b>CTS</b>       | Coolant temperature sensor   |
| <b>CNG</b>       | Compressed natural gas   |
| <b>Dual Fuel</b> | Able to run simultaneously on two fuels, e.g. diesel and natural gas. Often this term is incorrectly used to describe bi-fuel operation. Spark-ignited engines are typically bi-fuel while compression ignition engines are dual-fuel. |
| <b>ECM</b>       | Engine control module  |
| <b>FPP</b>       | Foot pedal position  |
| <b>FPV</b>       | Fuel primer valve  |
| <b>FTS</b>       | Fuel temperature sensor  |
| <b>FTV</b>       | Fuel trim valve  |
| <b>GPM</b>       | Gallons per minute of flow   |
| <b>HEGO</b>      | Heated exhaust gas oxygen (sensor)   |
| <b>LAT</b>       | Limited-angle torque motor   |
| <b>LPG</b>       | Liquified petroleum gas  |
| <b>MAP</b>       | Manifold absolute pressure   |
| <b>MAT</b>       | Manifold air temperature   |
| <b>MIL</b>       | Malfunction indicator lamp   |
| <b>MOR</b>       | Manufacturer of record for emissions certification on the engine   |
| <b>OEM</b>       | Original equipment manufacturer  |
| <b>PHI</b>       | Relative fuel-air ratio or percent of stoichiometric fuel<br>(actual fuel-air ratio / stoichiometric fuel-air ratio)   |
| <b>RPM</b>       | Revolutions per minute   |
| <b>SECM</b>      | Small engine control module  |
| <b>TMAP</b>      | Temperature and manifold absolute pressure   |
| <b>TPS</b>       | Throttle position sensor   |
| <b>VDC</b>       | Voltage of direct current type   |
| <b>VE</b>        | Volumetric efficiency  |
| <b>WOT</b>       | Wide open throttle   |

**We appreciate your comments about the content of our publications.**

**Send comments to: [icinfo@woodward.com](mailto:icinfo@woodward.com)**

**Please include the manual number from the front cover of this publication.**



PO Box 1519, Fort Collins CO 80522-1519, USA  
1000 East Drake Road, Fort Collins CO 80525, USA  
Phone +1 (970) 482-5811 • Fax +1 (970) 498-3058

**Email and Website—[www.woodward.com](http://www.woodward.com)**

**Woodward has company-owned plants, subsidiaries, and branches,  
as well as authorized distributors and other authorized service and sales facilities throughout  
the world.**

**Complete address / phone / fax / email information for all locations is available on our website.**