



MAV 500 VIDEO
GAMING MACHINE
ELECTRONIC PARTS CATALOG

(ACN 001 660 715)
(ABN 22-001-660-715)

AM - 1921503 - 01

The gaming machine described in this document may be covered by patents and registered designs. The information contained in this manual is the confidential proprietary property of Aristocrat Technologies Australia Pty Ltd. Absolutely no use, dissemination or copying in any matter whatsoever of this material or any portion of it is to be made without the prior written authorisation of Aristocrat Technologies Australia Pty Ltd. All rights in and to this work are fully reserved. In the event of publication, statutory copyright is claimed.

This document is not for use in countries where gaming machines are prohibited by law.

Aristocrat Technologies Australia Pty Ltd reserves the right to change, without notice, the design or specifications of the gaming machine covered by this document. Additional information is available from time to time in the form of technical bulletins. New editions of this document may change its contents.

CAUTION

UL APPROVED PARTS MUST
BE USED WHERE AVAILABLE

CAUTION

All functions of the machine are controlled by complex electronics. Unqualified personnel must not interfere with any mechanisms or controls as this may permanently damage the machine and lead to expensive repairs or component replacement, and will render the warranty void.

WARNING

This is a Class A product. In a domestic environment, this product may cause radio interference, in which case the user may be required to take adequate action.

Important Safety Information

This document contains important information about the use of the equipment and hazards involved in owning and operating the equipment to which it relates. The equipment can be very hazardous if used other than in accordance with this document.

Inform yourself and your staff

You must read this document before using the equipment or opening any part of the equipment. Ensure your staff do too.

The equipment itself is marked with important warning labels detailing dangers.

- Check for warning labels whenever opening any part of the equipment.
- Read and comply with all warning labels you see when operating or opening the equipment.
- Under no circumstances remove or alter any warning label.

Be careful

If you don't follow the directions in this manual and on warning labels you increase the risk of the following things occurring:

- **serious personal injury**, including electrocution and amputation. Unless you are a trained technician, tampering with the machine can kill you;
- serious damage to the equipment;
- serious damage to other equipment;
- serious damage to the premises housing the equipment.



Aristocrat MAV Manuals



Operator Manual

Primarily intended for operators of Aristocrat MAV Video Gaming Machines. The Operator Manual:

- gives a general overview of the hardware and software
- provides procedures for daily operations and simple maintenance.



Service Manual

Primarily intended for service technicians. The Service Manual:

- gives a general overview of the hardware and software
- provides instructions for installation and fault finding
- describes in detail each of the major components of the machine.



Parts Catalogue

Primarily intended for operators and service technicians. It enables operators and service technicians to order machine parts. The Parts Catalogue:

- shows an illustration of each of the components of the machine
- links each illustration with a part number.

Foreword

**This Parts Catalogue AM-1921503-01
Aristocrat U.S.A. MAV 500 (August: 2001),
covers the following:**

1. References to model variations, i.e. Light towers, etc., are included for use where those items are required and fitted.
2. Some items are listed “pending” where part numbers were not allocated at the time of going to print.
3. Where parts are referred to as “REFERENCE ONLY” they are generally not individually replaceable and the part numbers are given for Aristocrat Technical Services reference only.
4. Publishing of subsequent updated issues of the complete Parts Catalogue and/or individual pages will be identified by Issue “-03” replacing Issue “-02” in the I.D./Code number located at the bottom right hand corner of each text page & the bottom left hand corner of each illustration page.

The machines described herein are covered by patents and/or registered designs. Copying in any form is strictly prohibited without the written permission of Aristocrat Technologies Australia Pty. Ltd.

Aristocrat Technologies Australia Pty Ltd reserves the right to change, without notice, the design and/or specifications of the machines covered by this catalogue. However, additional information is, from time to time, available in the form of Updates and Technical Bulletins. This document itself is subject to change in the form of new issues indicated on that issue accordingly.

Issued - August 2001



Brief History of Aristocrat Technologies Australia Pty Ltd

Aristocrat Technologies Australia Pty Ltd, established in 1953, is one of the oldest and most successful gaming machine manufacturers. Aristocrat has supplied machines to every country and region in the world where gaming machines are legal, including Austria, France, Germany, Holland, Malaysia, New Zealand, the Philippines, Africa, Singapore, Russia, South America, and the USA.

Aristocrat Technologies Australia Pty Ltd employs over 1,400 people and has the largest gaming research and development facility in the Southern Hemisphere.

Offices

Spare Parts Department

PO Box 155, Rosebery, NSW 1445, Australia
Outside Australia Tel: 612 9697 4146 Fax: 612 9697 4199
Within Australia Tel: 02 9697 4146 Fax: 02 9697 4199

Head Office

New South Wales

Aristocrat Technologies Australia Pty Ltd (ACN 001 660 715),
71 Longueville Road, Lane Cove NSW 2066, Australia.
PO Box 808, Lane Cove NSW 1595, Australia.
Outside Australia Tel: 612 9413 6300 Fax 612 9420-1326
Within Australia Tel: 02 9413 6300 Fax 02 9420-1326

Manufacturing / Operations

New South Wales

Aristocrat Technologies Australia Pty Ltd (ACN 001 660 715),
85-113 Dunning Avenue, Rosebery NSW 2018, Australia.
Outside Australia Tel: 612 9697 4000 Fax: 612 9693 1340
Within Australia Tel: 02 9697 4000 Fax: 02 9693 1340

National Offices

South Australia

Aristocrat Technologies Australia Pty Ltd.
75 Henley Beach Road,
Mile End, Adelaide, South Australia 5031.
Outside Australia Tel: 6108 8352 0030 Fax: 618 8443 3606
Within Australia Tel: 08 8352 0030 Fax 08 8443 3606

Victoria

Aristocrat Technologies Australia Pty Ltd.
672 Lorimer Street, Port Melbourne, Victoria. 3207
Outside Australia Tel: 613 9644 1000 Fax: 613 9644 1032
Within Australia Tel: 03 9644 1000 Fax: 03 9644 1032

Queensland

Aristocrat Technologies Australia Pty. Ltd.
60-62 Commercial Drive, Shailer Park, Qld. 4128, Australia
Outside Australia Tel: 617 3801 4444 Fax 617 3801 4403
Within Australia Tel: 07 3801 4444 Fax 07 3801 4403

Western Australia

Aristocrat Technologies Australia Pty. Ltd.
PO Box 8206, Perth Business Centre, Perth WA 6846
Outside Australia Tel: 618 9355 1212 Fax: 618 9355 1213
Within Australia Tel: (08) 9355 1212 Fax: (08) 9355 1213

International Offices

Japan

Hiro Bld, 2-25-16 Shinmachi Setagaya-Ku
Tokyo Japan
Tel: 0011 813 576 00071 Fax: 0015 813 576 00072

International Offices (continued)

New Zealand

Auckland Office

Aristocrat Technologies NZ Ltd,
22 Vestey Drive, Mt. Wellington, Auckland, New Zealand.
Tel: 0011 64 9 270 1600 Fax: 0015 64 9 270 1601

Christchurch Office

Unit D 5 Tenahaun Place, Sockburn,
Christchurch, New Zealand.
Tel: 0011 64 3 338 7430 Fax: 0015 64 3 338 6492

Singapore

01-482 Bedok South Avenue 3
Block 69 Singapore 460069
Tel: 0011 65 444 5666

South Africa

Aristocrat Africa (Pty) Limited.
3 Kramer Road Kramerville Sandton, South Africa.
Tel: 0011 27 11 448 2320/1 Fax: 0015 27 11 448 2322

UK

Aristocrat Technologies Europe Ltd
Falcon Unit One, Stonefield Way, South Ruislip,
Middlesex HA4 OJS, England.
Tel: 0011 44 (0)208 426 5822 Fax: 0015 44 (0)208 426 5760

USA

Las Vegas

Aristocrat Technologies Incorporated,
7160 Bermuda Road, Suite 240
Las Vegas, Nevada 89119, USA
Tel: 0011 1702 952 4800 Fax: 0015 1702 952 5240

Aristocrat Technologies Incorporated,
3101 Marion Drive No. 107,
Las Vegas, Nevada NV 89115, USA.
Tel: 0011 1 702 64 2400 Fax: 0015 1 702 643 6890

Tucson

Aristocrat Technologies Incorporated,
5431 E. Williams Blvd,
Suite 151
Tucson, AZ 85711
Tel: 0011 15205198500

South America

8200 N.W. 27th Street, Office 104 Miami, Fl., 33122 USA
Tel: 0011 1 305 594 2881 Fax: 0015 1 305 594 9022



STATUS PAGE

AUTHOR	DATE	COMMENTS
G. Montgomery	24/8/2001	1 st Edition of Aristocrat U.S.A.MAV 500



PARTS CATALOGUE

CONTENTS LIST

SECTION	DESCRIPTION	PAGE No.s
1	SECTION REFERENCE	1-2 to 1-3
2	MAIN CABINET GENERAL COMPONENTS	2-1 to 2-3
3	TOP BOX ASSEMBLIES & COMPONENTS	3-1 to 3-3
4	MONITOR & COMPONENTS	4-1 to 4-3
5	HOPPERS & COMPONENTS	5-1 to 5-5
6	MAIN DOOR, GENERAL COMPONENTS	6-1 to 6-3
7	COIN COMPARATOR - COIN CHUTE	7-1 to 7-3
8	PANEL ART & DENOMINATION PATCHES	8-1 to 8-3
9	LIGHT TOWER	9-1 to 9-3
10	BILL ACCEPTOR, CAGE & COMPONENTS	10-1 to 10-3
11	CHIP TRAY, COMPONENTS FOR MAIN DOOR	11-1 to 11-3
12	BACC ESCUTCHEON/COIN ENTRY & P/BUTTON SW/TRIM	12-1 to 12-3
13	DOOR HINGES & COMPONENTS	13-1 to 13-3
14	DOOR LOCKING COMPONENTS	14-1 to 14-3
15	SPEAKERS / HARD METERS	15-1 to 15-3
16	LOOM ASSEMBLY for CAB. DOOR, C/CHUTE & REFLECTOR	16-1 to 16-3
17	LOOM ASSY for T/BOX & CABINET	17-1 to 17-3
18	SECURING MACHINES TO BASE	18-1 to 18-5

SECTION REFERENCE

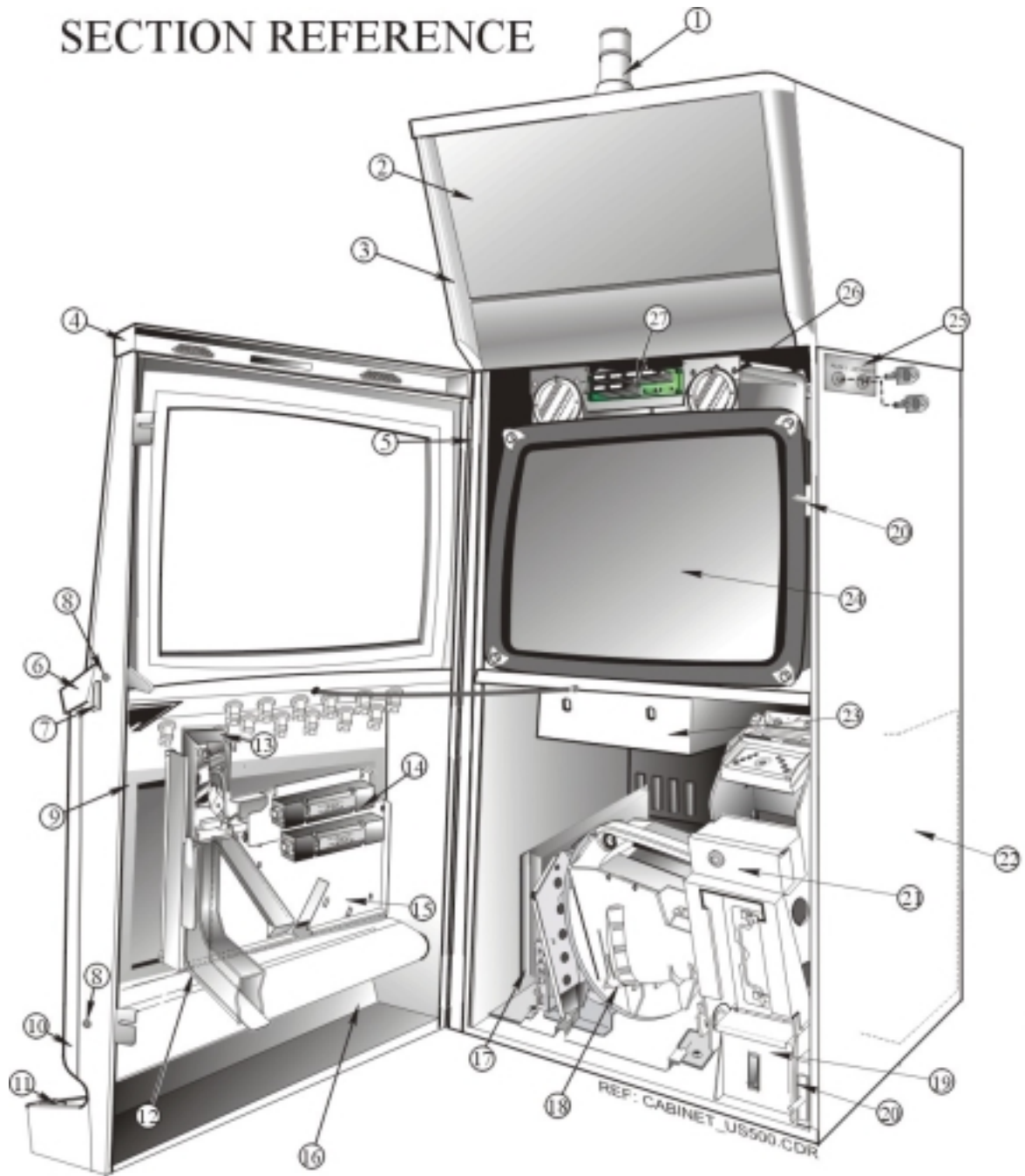

SECTION 1

SECTION REFERENCE

REF No.	DESCRIPTION	SECTION No.
1	LIGHT TOWER & COMPONENTS	SECTION 9
2	TOP BOX ART PANEL	SECTION 8
3	TOP BOX,	SECTION 3
4	TOP TRIM	SECTION 6
5	HINGES	SECTION 13
6	MID TRIM AND PUSH BUTTON ASSY	SECTION 12
7	HANDLE – MAIN DOOR	SECTION 6
8	MAIN DOOR & BELLY PANEL LOCKS	SECTION 14
9	MAIN DOOR LATCH	SECTION 14
10	BELLY PANEL DOOR	SECTION 6
	PANEL ART & DENOMINATION PATCHES.	SECTION 8
11	CHIP TRAY (Coin Tray)	SECTION 11
12	COIN CHUTE	SECTION 7
13	COIN VALIDATOR	SECTION 7
14	FLUORESCENT BALLASTS	SECTION 7
	BRACKET – BALLAST MOUNTING	SECTION 7
15	REFLECTOR PANEL	SECTION 7
	FLUOROS	SECTION 7
16	MAIN DOOR GENERAL COMPONENTS,	SECTION 6
17	WOOFER ASSEMBLY	SECTION 2
18	HOPPERS & COMPONENTS	SECTION 5
19	MAINS SWITCH	SECTION 2
20	MECHANICAL DOOR SWITCH	SECTION 2
21	BANK NOTE ACCEPTOR	SECTION 10
22	POWER SUPPLY ASSEMBLY	SECTION 2
23	LOGIC CAGE / PRINTED CIRCUIT BOARDS	SECTION 2
24	MONITOR & COMPONENTS	SECTION 4
25	AUDIT KEY SWITCH	SECTION 2
	JACKPOT KEY SWITCH	SECTION 2
26	SOUND SYTEM	SECTION 15
27	MECHANICAL METERS	SECTION 15
28	LOOM ASSEMBLY for CAB. DOOR, COIN CHUTE & REFLECTOR	SECTION 16
29	LOOMS ASSEMBLY for CABINET & TOP BOX	SECTION 17
30	SECURING MACHINES TO BASE	SECTION 18

SECTION 2

MAIN CABINET

GENERAL COMPONENTS



MAIN CABINET GENERAL COMPONENTS

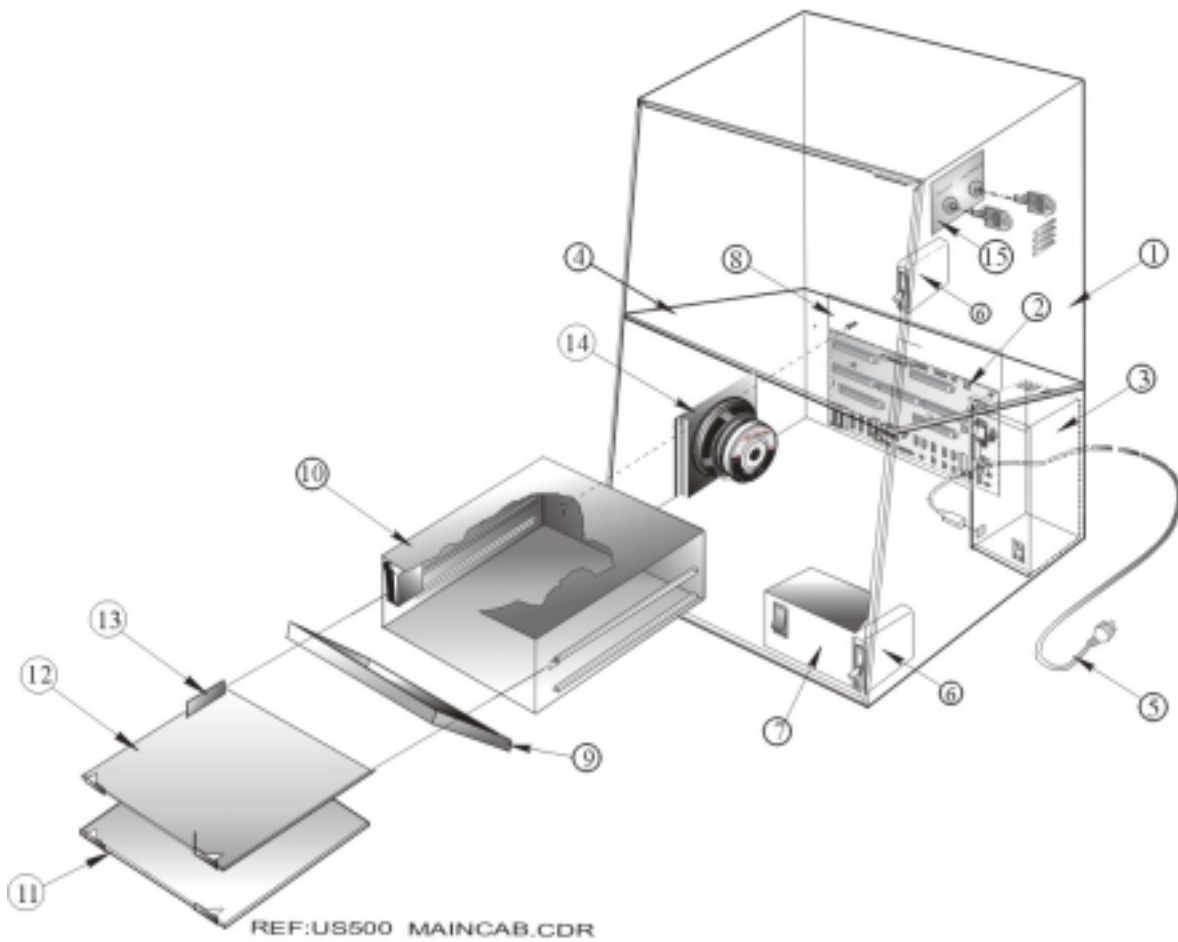

SECTION 2**MAIN CABINET
GENERAL COMPONENTS**

REF No.	DESCRIPTION	QTY	PARTNo.
1	CABINET/BODY – U.S.A. + GENERIC – (No Handle)	1	4501-300452
2	PCBA – MKV US BACKPLANE	1	2501-410351
3	POWER SUPPLY – 115V USA	1	3112-430947
4	SHELF – MONITOR (Part of Cabinet Assembly)		
5	LEAD – USA P+IEC_2.4metres BLACK	1	5815-560264
6	SWITCH, CHERRY - DOOR, E78-00A	1	6416-430795
7	MAIN SWITCH ASSEMBLY (Part of Ref: No.3 above.)	1	3111-565568
8	PANEL MVP – PGC	1	0944-571585
9	DOOR – MVP – PGC	1	0923-564829
	SHROUD – PGC DOOR (Not Illustrated)	1	0961-564830
10	BODY – MVP – PGC	1	0944-571584
	BRACKET – PGC RETAINER (Not Illustrated)	1	0923-571586
11	PCBA EXT. US I/O DRIVER BOARD	1	2501-410355
12	PCBA – MVP MAIN BOARD – (USA)	1	2501-410461
13	PCBA – COMMS CONFIG	1	2501-410291
14	WOOFER ASSEMBLY	1	3120-572285
	NUT – NYLOC M5	4	6612-07719
	LOOM ASSEMBLY – PLUG BREAK to DOOR SWITCH	1	3109-572817
15	KEY SWITCH KIT JACKPOT/AUDIT – (GENERAL)	1	3316-565091-1
16	LATCH - LOGIC CAGE (Not Illustrated)	1	0937-562971



SECTION 3

TOP BOX GENERAL COMPONENTS



TOP BOXES

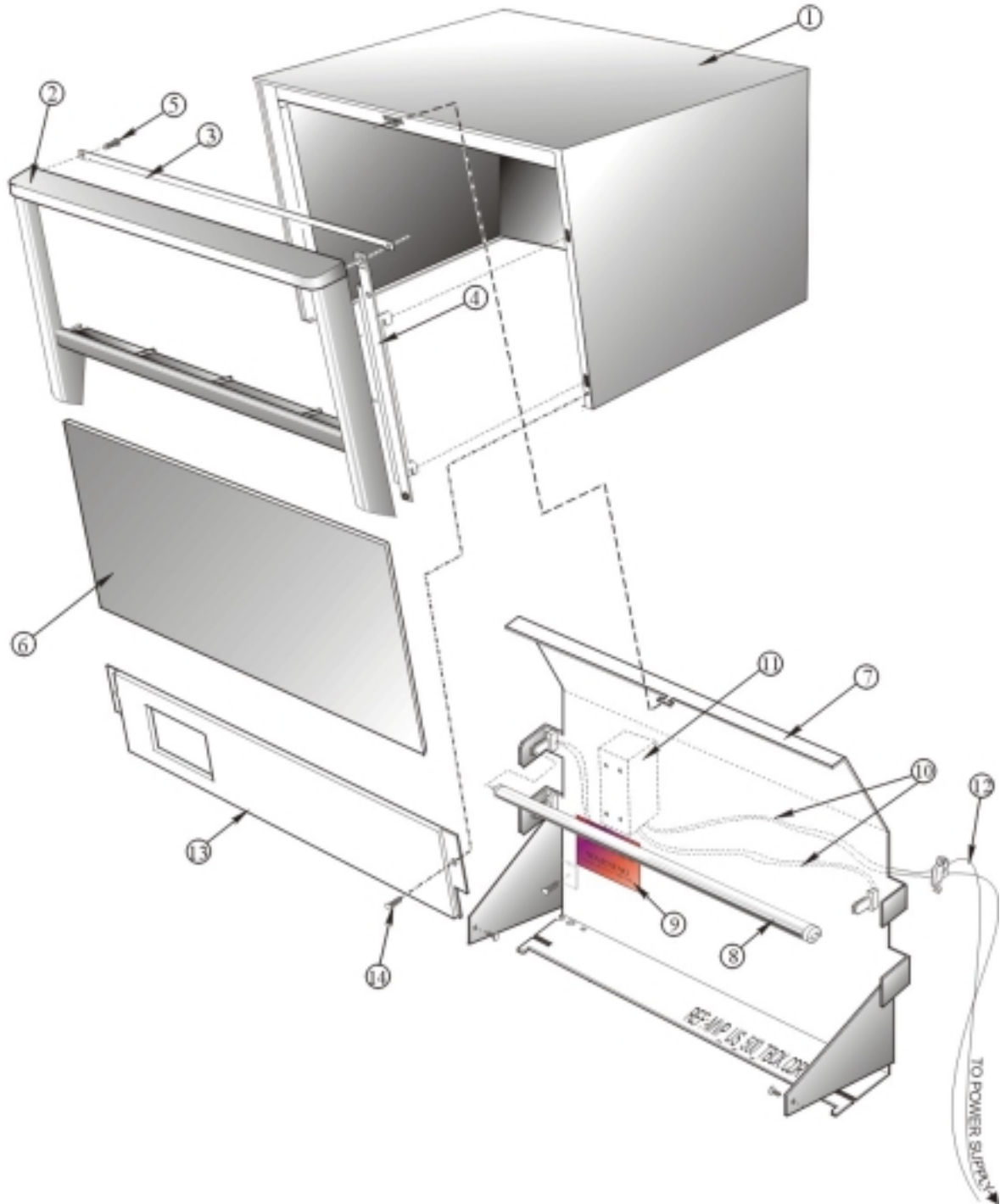

SECTION 3

TOP BOX
GENERAL COMPONENTS

REF No.	DESCRIPTION	QTY	PARTNo.
1	TOP BOX ASSEMBLY (Casino)	1	2209-572494
2	FRAME DOOR	1	0743-572316
3	BRACKET DOOR TOP	1	0913-572504
4	BRACKET DOOR R/H	1	0913-572505_1
	BRACKET DOOR L/H	1	0913-572505_2
	BRACKET DOOR BOTTOM (Not Illustrated)	1	0913-572506
	BRACKET – DOOR R.H.ART RETAINER	1	0913-572510_1
	BRACKET – DOOR L.H.ART RETAINER	1	0913-572510_2
	PANEL – ARTWORK BACKING 2mm	1	0507-572511_28
5	SCREW- 8x5/8	7	5742-04869
6	ART PANEL-TOP BOX (Refer to Section 8)		
7	REFLECTOR	1	0947-572509
8	LAMP - FLUORESCENT (15W)	1	5506-03441
9	LABEL - DANGER/WARNING (On Fluoro Reflector)	2	0104-09572
10	LOOM – TOP BOX FLUORO	1	3105-565126
11	BALLAST ASSEMBLY –FLUORO 15W	1	5501-430946
	COVER – BALLAST PCB (Not Illustrated)	2	0713-565130
12	LOOM – P_S_FLUORO_PCB	1	3109-568444
13	FRONT PANEL PMM BRIGHT CHROME (No Printer)	1	0944-573345_301
	FRONT PANEL PMM SATIN CHROME (No Printer)	1	0944-573345_304
	FRONT PANEL PMM BLACK ONYX (No Printer)	1	0944-573345_306
	FRONT PANEL PMM BRIGHT CHROME (SEIKO Printer)	1	0944-573345_101
	FRONT PANEL PMM SATIN CHROME (SEIKO Printer)	1	0944-573345_104
	FRONT PANEL PMM BLACK ONYX (SEIKO Printer)	1	0944-573345_106
	FRONT PANEL PMM BRIGHT CHROME (ITHACA Printer)	1	0944-573345_201
	FRONT PANEL PMM SATIN CHROME (ITHACA Printer)	1	0944-573345_204
	FRONT PANEL PMM BLACK ONYX (ITHACA Printer)	1	0944-573345_206
	FRONT PANEL PMM BRIGHT CHROME (JCM Printer)	1	0944-573345_401
	FRONT PANEL PMM SATIN CHROME (JCM Printer)	1	0944-573345_404
	FRONT PANEL PMM BLACK ONYX (JCM Printer)	1	0944-573345_406
13A	REAR PNL PMM Bright Chrome (ACRES No Printer) (Not Illustrated)	1	0944-573370_0101
	REAR PNL PMM Satin Chrome (ACRES No Printer) (Not Illustrated)	1	0944-573370_0104
	REAR PNL PMM Black Onyx (ACRES No Printer) (Not Illustrated)	1	0944-573370_0106
	REAR PNL PMM Bright Chrome (ACRES with Printer) (Not Illustrated)	1	0944-573348_0101
	REAR PNL PMM Satin Chrome (ACRES with Printer) (Not Illustrated)	1	0944-573348_0104
	REAR PNL PMM Black Onyx (ACRES with Printer) (Not Illustrated)	1	0944-573348_0106
	REAR PNL PMM Bright Chrome (MIKOHN No Printer) (Not Illustrated)	1	0944-573370_0201
	REAR PNL PMM Satin Chrome (MIKOHN No Printer) (Not Illustrated)	1	0944-573370_0204
	REAR PNL PMM Black Onyx (MIKOHN No Printer) (Not Illustrated)	1	0944-573370_0206
	REAR PNL PMM Bright Chrome (MIKOHN with Printer) (Not Illustrated)	1	0944-573348_0201
	REAR PNL PMM Satin Chrome (MIKOHN with Printer) (Not Illustrated)	1	0944-573348_0204
	REAR PNL PMM Black Onyx (MIKOHN with Printer) (Not Illustrated)	1	0944-573348_0206



TOP BOXES

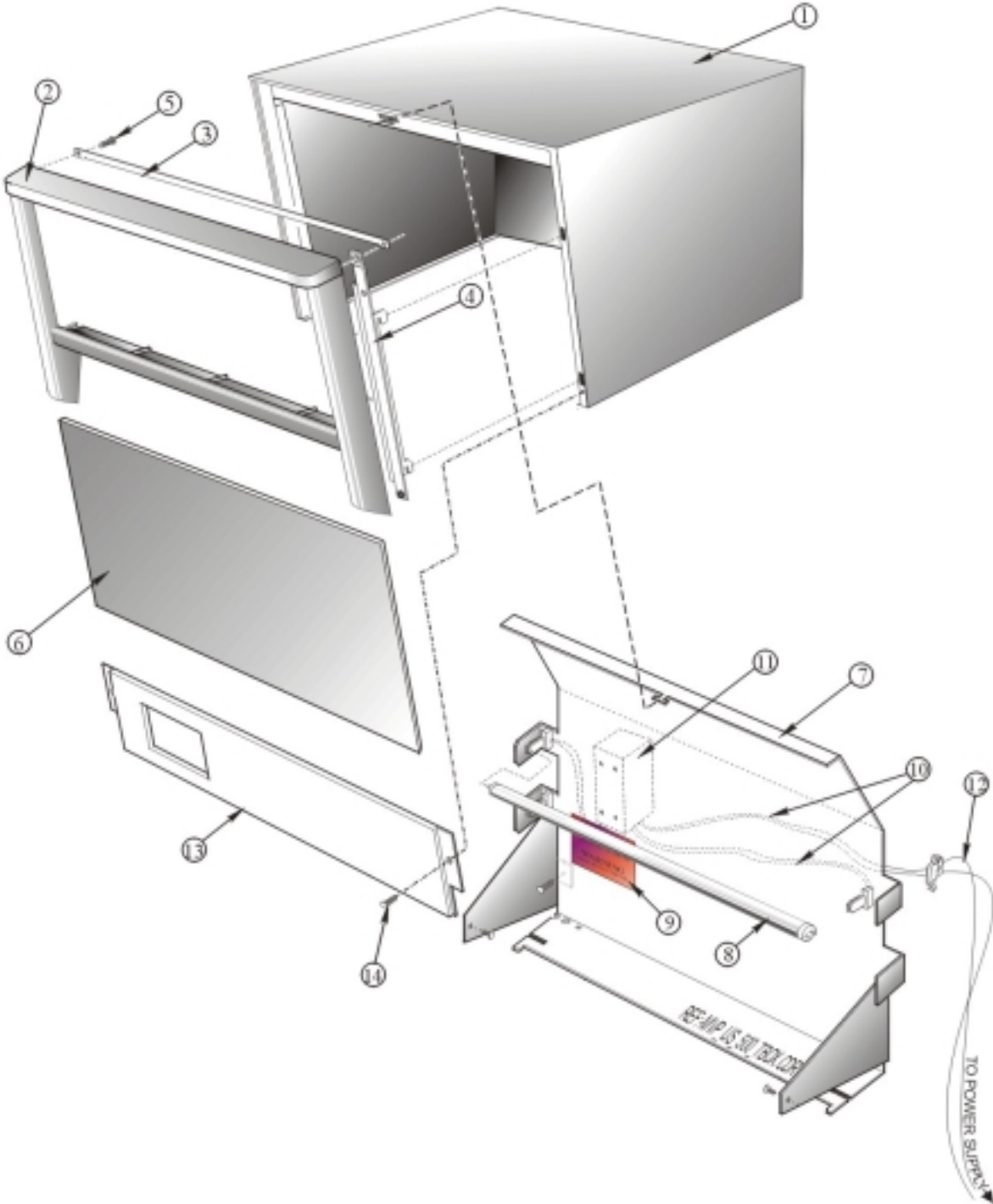

SECTION 3

TOP BOX

GENERAL COMPONENTS

REF No.	DESCRIPTION	QTY	PARTNo.
13A	REAR PNL PMM Bright Chrome (BALLY EPI LCD No Printer) (Not Illustrated)	1	0944-573370_0401
	REAR PNL PMM Satin Chrome (BALLY EPI LCD No Printer) (Not Illustrated)	1	0944-573370_0404
	REAR PNL PMM Black Onyx (BALLY EPI LCD No Printer) (Not Illustrated)	1	0944-573370_0406
	REAR PNL PMM Bright Chrome (BALLY EPI LCD with Printer) (Not Illustrated)	1	0944-573348_0401
	REAR PNL PMM Satin Chrome (BALLY EPI LCD with Printer) (Not Illustrated)	1	0944-573348_0404
	REAR PNL PMM Black Onyx (BALLY EPI LCD with Printer) (Not Illustrated)	1	0944-573348_0406
	REAR PNL PMM Bright Chrome (BALLY EPI Fluoro Display No Printer) (Not Illustrated)	1	0944-573370_0501
	REAR PNL PMM Satin Chrome (BALLY EPI Fluoro Display No Printer) (Not Illustrated)	1	0944-573370_0504
	REAR PNL PMM Black Onyx (BALLY EPI Fluoro Display No Printer) (Not Illustrated)	1	0944-573370_0506
	REAR PNL PMM Bright Chrome (BALLY EPI Fluoro with Printer) (Not Illustrated)	1	0944-573348_0501
	REAR PNL PMM Satin Chrome (BALLY EPI Fluoro with Printer) (Not Illustrated)	1	0944-573348_0504
	REAR PNL PMM Black Onyx (BALLY EPI Fluoro with Printer) (Not Illustrated)	1	0944-573348_0506
	REAR PNL PMM Bright Chrome (BALLY - SDS No Printer) (Not Illustrated)	1	0944-573370_0601
	REAR PNL PMM Satin Chrome (BALLY - SDS No Printer) (Not Illustrated)	1	0944-573370_0604
	REAR PNL PMM Black Onyx (BALLY - SDS No Printer) (Not Illustrated)	1	0944-573370_0606
	REAR PNL PMM Bright Chrome (BALLY - SDS with Printer) (Not Illustrated)	1	0944-573348_0601
	REAR PNL PMM Satin Chrome (BALLY - SDS with Printer) (Not Illustrated)	1	0944-573348_0604
	REAR PNL PMM Black Onyx (BALLY - SDS with Printer) (Not Illustrated)	1	0944-573348_0606
	REAR PNL PMM Bright Chrome (BALLY - CDS LARGE No Printer) (Not Illustrated)	1	0944-573370_0801
	REAR PNL PMM Satin Chrome (BALLY - CDS LARGE No Printer) (Not Illustrated)	1	0944-573370_0804
	REAR PNL PMM Black Onyx (BALLY - CDS LARGE No Printer) (Not Illustrated)	1	0944-573370_0806
	REAR PNL PMM Bright Chrome (BALLY - CDS LARGE with Printer) (Not Illustrated)	1	0944-573348_0801
	REAR PNL PMM Satin Chrome (BALLY - CDS LARGE with Printer) (Not Illustrated)	1	0944-573348_0804
	REAR PNL PMM Black Onyx (BALLY - CDS LARGE with Printer) (Not Illustrated)	1	0944-573348_0806
	REAR PNL PMM Bright Chrome (BALLY - CDS SMALL No Printer) (Not Illustrated)	1	0944-573370_1001
	REAR PNL PMM Satin Chrome (BALLY - CDS SMALL No Printer) (Not Illustrated)	1	0944-573370_1004
	REAR PNL PMM Black Onyx (BALLY - CDS SMALL No Printer) (Not Illustrated)	1	0944-573370_1006
	REAR PNL PMM Bright Chrome (BALLY - CDS SMALL with Printer) (Not Illustrated)	1	0944-573348_1001
	REAR PNL PMM Satin Chrome (BALLY - CDS SMALL with Printer) (Not Illustrated)	1	0944-573348_1004
	REAR PNL PMM Black Onyx (BALLY - CDS SMALL with Printer) (Not Illustrated)	1	0944-573348_1006
	REAR PNL PMM Bright Chrome (GSI No Printer) (Not Illustrated)	1	0944-573370_1201
	REAR PNL PMM Satin Chrome (GSI No Printer) (Not Illustrated)	1	0944-573370_1204
	REAR PNL PMM Black Onyx (GSI No Printer) (Not Illustrated)	1	0944-573370_1206
	REAR PNL PMM Bright Chrome (GSI with Printer) (Not Illustrated)	1	0944-573348_1201
	REAR PNL PMM Satin Chrome (GSI with Printer) (Not Illustrated)	1	0944-573348_1204
	REAR PNL PMM Black Onyx (GSI with Printer) (Not Illustrated)	1	0944-573348_1206
	REAR PNL PMM Bright Chrome (IGT / IGS No Printer) (Not Illustrated)	1	0944-573370_1401
	REAR PNL PMM Satin Chrome (IGT / IGS No Printer) (Not Illustrated)	1	0944-573370_1404
	REAR PNL PMM Black Onyx (IGT / IGS No Printer) (Not Illustrated)	1	0944-573370_1406
	REAR PNL PMM Bright Chrome (IGT / IGS with Printer) (Not Illustrated)	1	0944-573348_1401
	REAR PNL PMM Satin Chrome (IGT / IGS with Printer) (Not Illustrated)	1	0944-573348_1404
	REAR PNL PMM Black Onyx (IGT / IGS with Printer) (Not Illustrated)	1	0944-573348_1406
	REAR PNL PMM Bright Chrome (ACSC / SMS No Printer) (Not Illustrated)	1	0944-573370_1601
	REAR PNL PMM Satin Chrome (ACSC / SMS No Printer) (Not Illustrated)	1	0944-573370_1604
	REAR PNL PMM Black Onyx (ACSC / SMS No Printer) (Not Illustrated)	1	0944-573370_1606
	REAR PNL PMM Bright Chrome (ACSC / SMS with Printer) (Not Illustrated)	1	0944-573348_1601
	REAR PNL PMM Satin Chrome (ACSC / SMS with Printer) (Not Illustrated)	1	0944-573348_1604
	REAR PNL PMM Black Onyx (ACSC / SMS with Printer) (Not Illustrated)	1	0944-573348_1606
	REAR PNL PMM Bright Chrome (PARADIGM No Printer) (Not Illustrated)	1	0944-573370_1801
	REAR PNL PMM Satin Chrome (PARADIGM No Printer) (Not Illustrated)	1	0944-573370_1804
	REAR PNL PMM Black Onyx (PARADIGM No Printer) (Not Illustrated)	1	0944-573370_1806
	REAR PNL PMM Bright Chrome (PARADIGM with Printer) (Not Illustrated)	1	0944-573348_1801
	REAR PNL PMM Satin Chrome (PARADIGM with Printer) (Not Illustrated)	1	0944-573348_1804
	REAR PNL PMM Black Onyx (PARADIGM with Printer) (Not Illustrated)	1	0944-573348_1806
14	SCREW - 8x5/8	7	5742-04869
15	TRAY - PMM (Not Illustrated)	1	0957-572507



TOP BOX ROUND

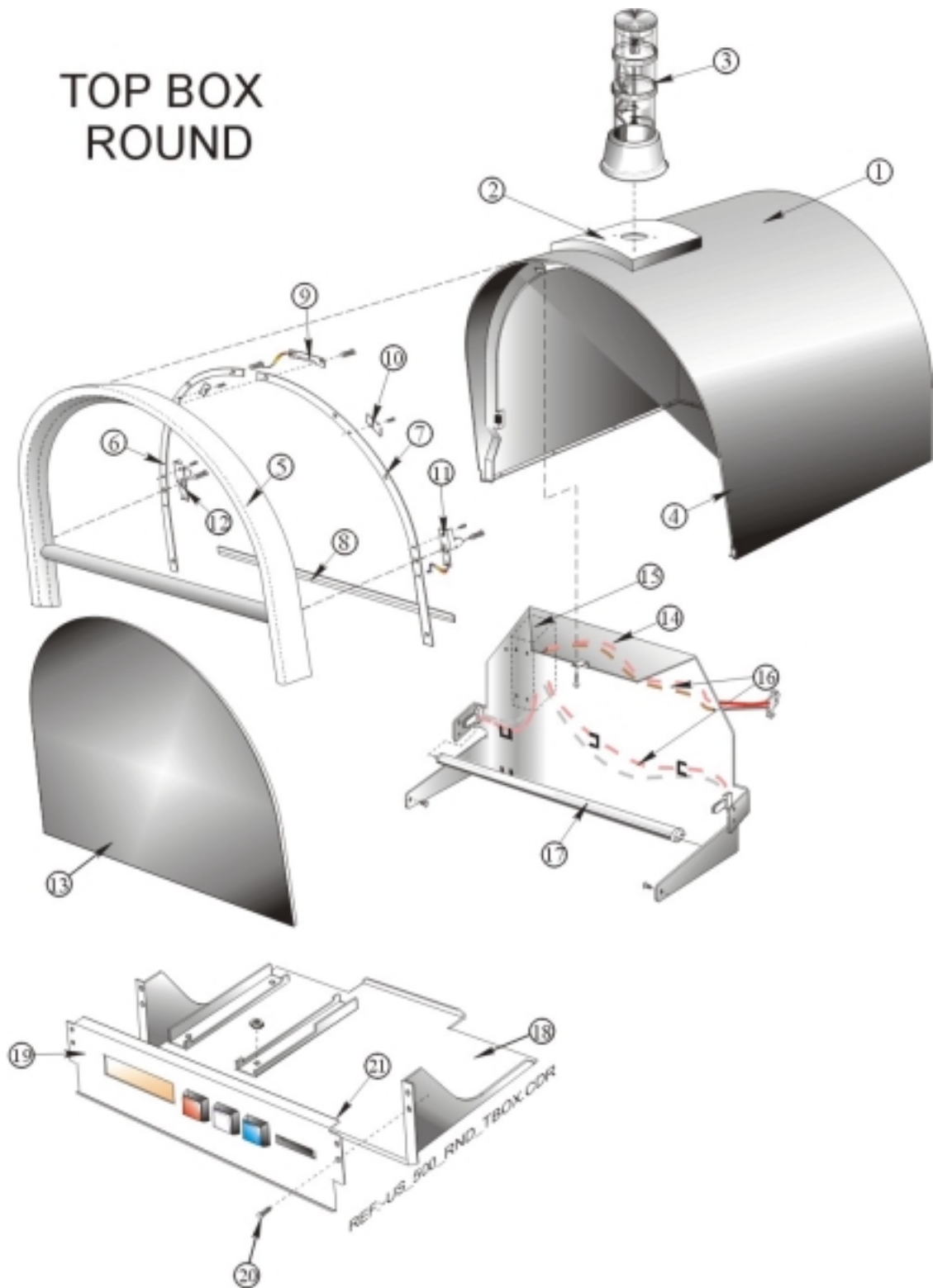

SECTION 3

TOP BOX
GENERAL COMPONENTS

REF No.	DESCRIPTION	QTY	PARTNo.
1	TOP BOX – ROUND (Black Onyx)	1	2243-572492_06
	TOP BOX – ROUND (Black Satin)	1	2243-572492_36
2	MOUNTING – LIGHT TOWER	1	0961-563650
3	LIGHT TOWER (IGT) Supplied ex USA Factory		
4	SPRING – EARTH ROUND TOP BOX	1	1002-572587
5	FRAME – DOOR ROUND (Bright Chrome)	1	0743-572526_101
	FRAME – DOOR ROUND (Bright Gold)	1	0743-572526_102
	FRAME – DOOR ROUND (Satin Chrome)	1	0743-572526_104
	FRAME – DOOR ROUND (Satin Gold)	1	0743-572526_105
	FRAME – DOOR ROUND (Black Onyx)	1	0743-572526_106
6	BRACKET SUPPORT L.H.	1	0913-572864_2
7	BRACKET SUPPORT R.H.	1	0913-572864_1
	SCREW (for bracket fixing)	8	5762-563051
8	BRACKET – DOOR BOTTOM FLAT	1	0913-572506
9	BRACKET – FRAME TOP ROUND	1	0926-572832
10	BRACKET – GLASS RETAINER ROUND	2	0948-572833
11	BRACKET – ART RETAINER R.H.	1	0948-572834_1
12	BRACKET – ART RETAINER L.H.	1	0948-572834_2
13	PANEL ARTWORK – (Glass 5.0 mm)	1	0507-572836_1
	PANEL ARTWORK – (PVC 2.0 mm)	1	0507-572836_8
	PANEL ARTWORK – (PVC 3.0 mm)	1	0507-572836_5
	PANEL ARTWORK – (PVC 4.5 mm)	1	0507-572836_3
	PANEL ARTWORK – (ACRYLIC 3.0 mm)	1	0507-572836_7
14	REFLECTOR ROUND	1	0947-572476
15	BALLAST ASSEMBLY –FLUORO 15W	1	5501-430946
	COVER – BALLAST PCB	2	0713-565130
16	LOOM – TOP BOX FLUORO	1	3105-565126
17	LAMP - FLUORESCENT (15W)	1	5506-03441
18	TRAY – PMM	1	0957-572507
19	FRONT PANEL PMM BRIGHT CHROME (No Printer)	1	0944-573345_301
	FRONT PANEL PMM SATIN CHROME (No Printer)	1	0944-573345_304
	FRONT PANEL PMM BLACK ONYX (No Printer)	1	0944-573345_306
	FRONT PANEL PMM BRIGHT CHROME (SEIKO Printer)	1	0944-573345_101
	FRONT PANEL PMM SATIN CHROME (SEIKO Printer)	1	0944-573345_104
	FRONT PANEL PMM BLACK ONYX (SEIKO Printer)	1	0944-573345_106
	FRONT PANEL PMM BRIGHT CHROME (ITHACA Printer)	1	0944-573345_201
	FRONT PANEL PMM SATIN CHROME (ITHACA Printer)	1	0944-573345_204
	FRONT PANEL PMM BLACK ONYX (ITHACA Printer)	1	0944-573345_206
	FRONT PANEL PMM BRIGHT CHROME (JCM Printer)	1	0944-573345_401
	FRONT PANEL PMM SATIN CHROME (JCM Printer)	1	0944-573345_404
	FRONT PANEL PMM BLACK ONYX (JCM Printer)	1	0944-573345_406
20	SCREW- 8x5/8	13	5742-04869
21	REAR PNL PMM Bright Chrome (ACRES No Printer) (Not Illustrated)	1	0944-573370_0101
	REAR PNL PMM Satin Chrome (ACRES No Printer) (Not Illustrated)	1	0944-573370_0104
	REAR PNL PMM Black Onyx (ACRES No Printer) (Not Illustrated)	1	0944-573370_0106
	REAR PNL PMM Bright Chrome (ACRES with Printer) (Not Illustrated)	1	0944-573348_0101
	REAR PNL PMM Satin Chrome (ACRES with Printer) (Not Illustrated)	1	0944-573348_0104
	REAR PNL PMM Black Onyx (ACRES with Printer) (Not Illustrated)	1	0944-573348_0106



TOP BOX ROUND

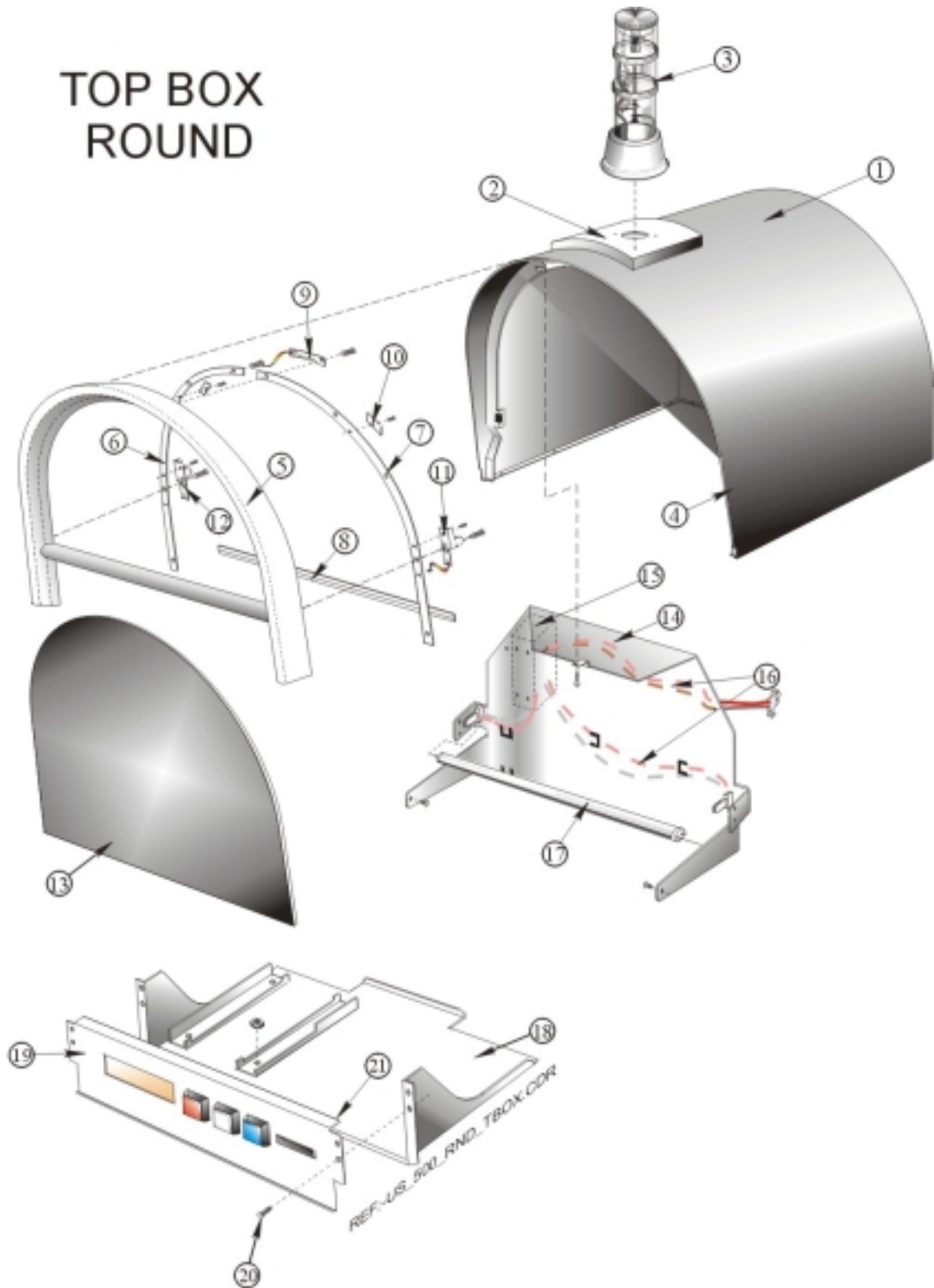

SECTION 3

TOP BOX
GENERAL COMPONENTS

REF No.	DESCRIPTION	QTY	PARTNo.
REAR PNL PMM	Bright Chrome (MIKOHN No Printer) (Not Illustrated)	1	0944-573370_0201
REAR PNL PMM	Satin Chrome (MIKOHN No Printer) (Not Illustrated)	1	0944-573370_0204
REAR PNL PMM	Black Onyx (MIKOHN No Printer) (Not Illustrated)	1	0944-573370_0206
REAR PNL PMM	Bright Chrome (MIKOHN with Printer) (Not Illustrated)	1	0944-573348_0201
REAR PNL PMM	Satin Chrome (MIKOHN with Printer) (Not Illustrated)	1	0944-573348_0204
REAR PNL PMM	Black Onyx (MIKOHN with Printer) (Not Illustrated)	1	0944-573348_0206
REAR PNL PMM	Bright Chrome (BALLY EPI LCD No Printer) (Not Illustrated)	1	0944-573370_0401
REAR PNL PMM	Satin Chrome (BALLY EPI LCD No Printer) (Not Illustrated)	1	0944-573370_0404
REAR PNL PMM	Black Onyx (BALLY EPI LCD No Printer) (Not Illustrated)	1	0944-573370_0406
REAR PNL PMM	Bright Chrome (BALLY EPI LCD with Printer) (Not Illustrated)	1	0944-573348_0401
REAR PNL PMM	Satin Chrome (BALLY EPI LCD with Printer) (Not Illustrated)	1	0944-573348_0404
REAR PNL PMM	Black Onyx (BALLY EPI LCD with Printer) (Not Illustrated)	1	0944-573348_0406
REAR PNL PMM	Bright Chrome (BALLY EPI Fluoro Display No Printer) (Not Illustrated)	1	0944-573370_0501
REAR PNL PMM	Satin Chrome (BALLY EPI Fluoro Display No Printer) (Not Illustrated)	1	0944-573370_0504
REAR PNL PMM	Black Onyx (BALLY EPI Fluoro Display No Printer) (Not Illustrated)	1	0944-573370_0506
REAR PNL PMM	Bright Chrome (BALLY EPI Fluoro with Printer) (Not Illustrated)	1	0944-573348_0501
REAR PNL PMM	Satin Chrome (BALLY EPI Fluoro with Printer) (Not Illustrated)	1	0944-573348_0504
REAR PNL PMM	Black Onyx (BALLY EPI Fluoro with Printer) (Not Illustrated)	1	0944-573348_0506
REAR PNL PMM	Bright Chrome (BALLY - SDS No Printer) (Not Illustrated)	1	0944-573370_0601
REAR PNL PMM	Satin Chrome (BALLY - SDS No Printer) (Not Illustrated)	1	0944-573370_0604
REAR PNL PMM	Black Onyx (BALLY - SDS No Printer) (Not Illustrated)	1	0944-573370_0606
REAR PNL PMM	Bright Chrome (BALLY - SDS with Printer) (Not Illustrated)	1	0944-573348_0601
REAR PNL PMM	Satin Chrome (BALLY - SDS with Printer) (Not Illustrated)	1	0944-573348_0604
REAR PNL PMM	Black Onyx (BALLY - SDS with Printer) (Not Illustrated)	1	0944-573348_0606
REAR PNL PMM	Bright Chrome (BALLY - CDS LARGE No Printer) (Not Illustrated)	1	0944-573370_0801
REAR PNL PMM	Satin Chrome (BALLY - CDS LARGE No Printer) (Not Illustrated)	1	0944-573370_0804
REAR PNL PMM	Black Onyx (BALLY - CDS LARGE No Printer) (Not Illustrated)	1	0944-573370_0806
REAR PNL PMM	Bright Chrome (BALLY - CDS LARGE with Printer) (Not Illustrated)	1	0944-573348_0801
REAR PNL PMM	Satin Chrome (BALLY - CDS LARGE with Printer) (Not Illustrated)	1	0944-573348_0804
REAR PNL PMM	Black Onyx (BALLY - CDS LARGE with Printer) (Not Illustrated)	1	0944-573348_0806
REAR PNL PMM	Bright Chrome (BALLY - CDS SMALL No Printer) (Not Illustrated)	1	0944-573370_1001
REAR PNL PMM	Satin Chrome (BALLY - CDS SMALL No Printer) (Not Illustrated)	1	0944-573370_1004
REAR PNL PMM	Black Onyx (BALLY - CDS SMALL No Printer) (Not Illustrated)	1	0944-573370_1006
REAR PNL PMM	Bright Chrome (BALLY - CDS SMALL with Printer) (Not Illustrated)	1	0944-573348_1001
REAR PNL PMM	Satin Chrome (BALLY - CDS SMALL with Printer) (Not Illustrated)	1	0944-573348_1004
REAR PNL PMM	Black Onyx (BALLY - CDS SMALL with Printer) (Not Illustrated)	1	0944-573348_1006
REAR PNL PMM	Bright Chrome (GSI No Printer) (Not Illustrated)	1	0944-573370_1201
REAR PNL PMM	Satin Chrome (GSI No Printer) (Not Illustrated)	1	0944-573370_1204
REAR PNL PMM	Black Onyx (GSI No Printer) (Not Illustrated)	1	0944-573370_1206
REAR PNL PMM	Bright Chrome (GSI with Printer) (Not Illustrated)	1	0944-573348_1201
REAR PNL PMM	Satin Chrome (GSI with Printer) (Not Illustrated)	1	0944-573348_1204
REAR PNL PMM	Black Onyx (GSI with Printer) (Not Illustrated)	1	0944-573348_1206
REAR PNL PMM	Bright Chrome (IGT / IGS No Printer) (Not Illustrated)	1	0944-573370_1401
REAR PNL PMM	Satin Chrome (IGT / IGS No Printer) (Not Illustrated)	1	0944-573370_1404
REAR PNL PMM	Black Onyx (IGT / IGS No Printer) (Not Illustrated)	1	0944-573370_1406
REAR PNL PMM	Bright Chrome (IGT / IGS with Printer) (Not Illustrated)	1	0944-573348_1401
REAR PNL PMM	Satin Chrome (IGT / IGS with Printer) (Not Illustrated)	1	0944-573348_1404
REAR PNL PMM	Black Onyx (IGT / IGS with Printer) (Not Illustrated)	1	0944-573348_1406
REAR PNL PMM	Bright Chrome (ACSC / SMS No Printer) (Not Illustrated)	1	0944-573370_1601
REAR PNL PMM	Satin Chrome (ACSC / SMS No Printer) (Not Illustrated)	1	0944-573370_1604
REAR PNL PMM	Black Onyx (ACSC / SMS No Printer) (Not Illustrated)	1	0944-573370_1606
REAR PNL PMM	Bright Chrome (ACSC / SMS with Printer) (Not Illustrated)	1	0944-573348_1601
REAR PNL PMM	Satin Chrome (ACSC / SMS with Printer) (Not Illustrated)	1	0944-573348_1604
REAR PNL PMM	Black Onyx (ACSC / SMS with Printer) (Not Illustrated)	1	0944-573348_1606
REAR PNL PMM	Bright Chrome (PARADIGM No Printer) (Not Illustrated)	1	0944-573370_1801
REAR PNL PMM	Satin Chrome (PARADIGM No Printer) (Not Illustrated)	1	0944-573370_1804
REAR PNL PMM	Black Onyx (PARADIGM No Printer) (Not Illustrated)	1	0944-573370_1806
REAR PNL PMM	Bright Chrome (PARADIGM with Printer) (Not Illustrated)	1	0944-573348_1801
REAR PNL PMM	Satin Chrome (PARADIGM with Printer) (Not Illustrated)	1	0944-573348_1804
REAR PNL PMM	Black Onyx (PARADIGM with Printer) (Not Illustrated)	1	0944-573348_1806



SECTION 4

MONITOR & COMPONENTS



MONITOR & COMPONENTS

MONITOR & COMPONENTS

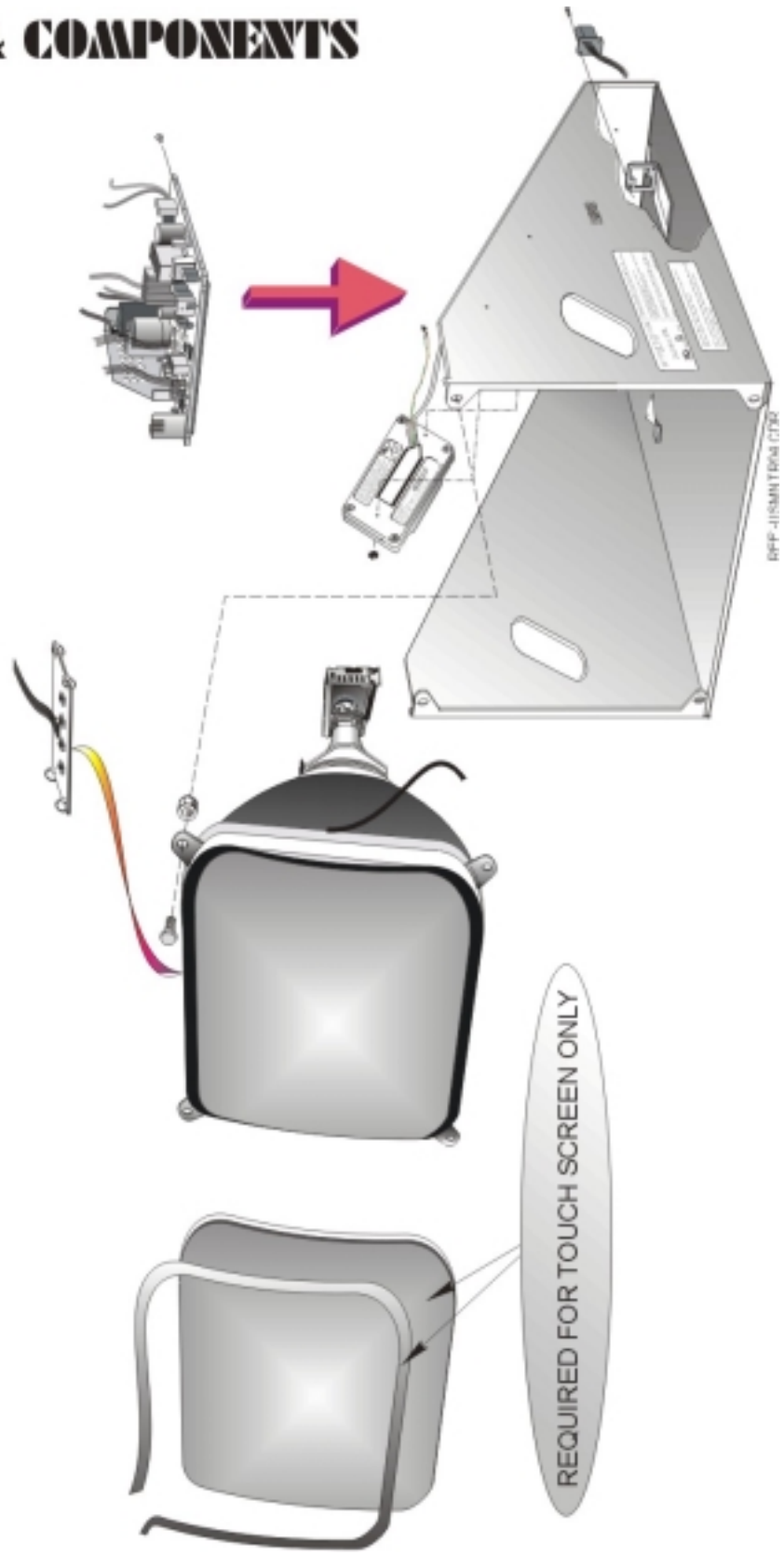

SECTION 4

MONITOR & COMPONENTS

REF No.	DESCRIPTION	QTY	PARTNo.
---------	-------------	-----	---------

The Monitor Assembly is Complete

There are no Replacement or Serviceable Parts in this Assembly

1	MONITOR ASSEMBLY - TOUCH SCREEN (Universal)	1	3316-571085-07
	MONITOR ASSEMBLY – NON TOUCH SCREEN (Universal)	1	3316-571085-06



SECTION 5

HOPPER & COMPONENTS

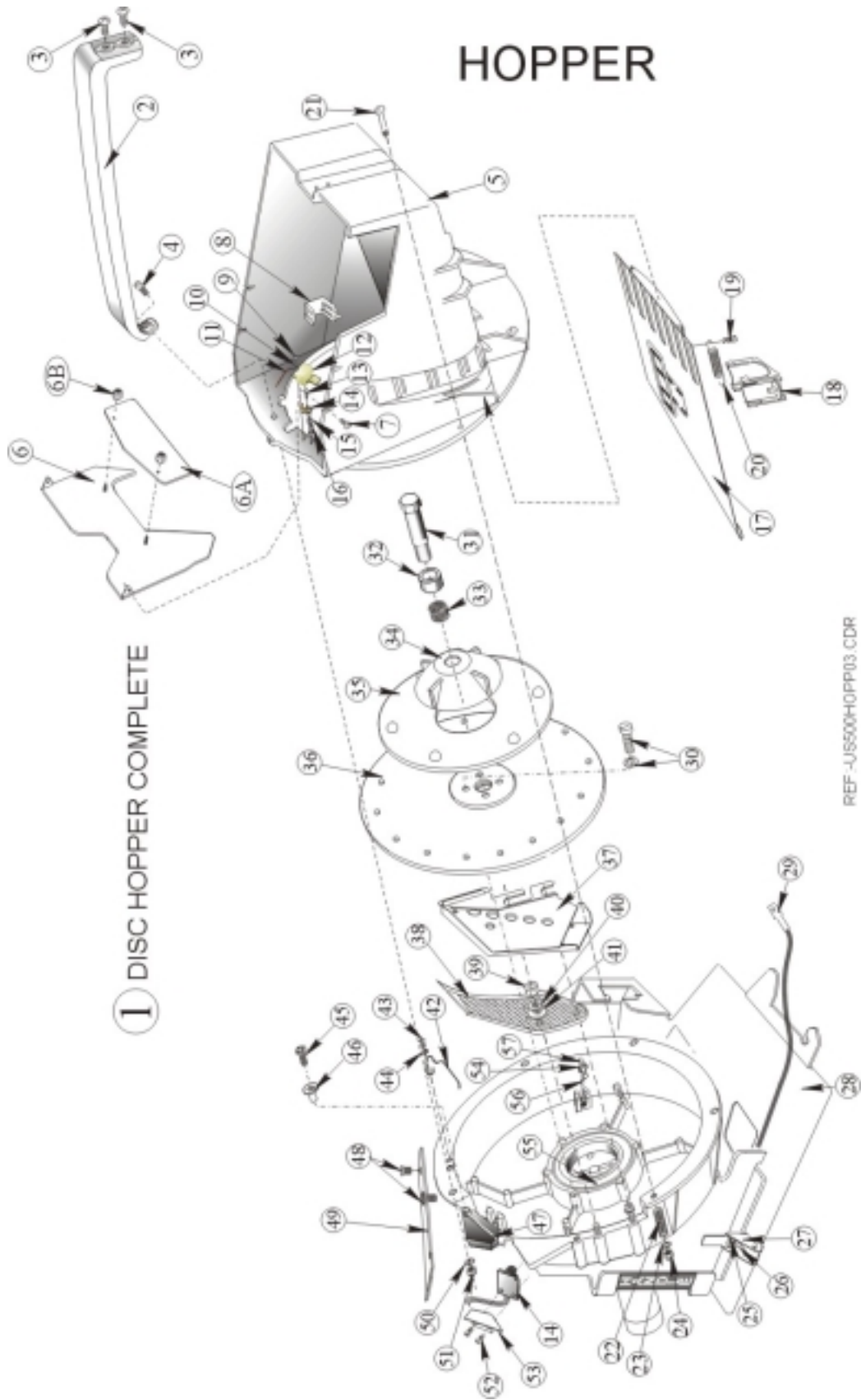

SECTION 5

HOPPERS AND COMPONENTS

REF No.	DESCRIPTION	QTY	PARTNo.
1	DISK HOPPER ASSEMBLY – F A GIANT – 5c USA (No Lid)	1	3802-568446-1134
2	HANDLE – HOPPER	1	0743-567679
3	SCREW – HOPPER HANDLE – M4 x 12 HI LO THREAD PAN HEAD PHILLIPS	2	5772-566175
4	SCREW – HOPPER HANDLE – HEX HEAD M5 x 20 ZINC	1	5753-02662
5	BOWL – LARGE HOPPER	1	0706-567675
6	BAFFLE – LARGE HOPPER BOWL	1	0905-572512
6A	PLATE – BAFFLE HOPPER BOWL	1	0945-572516
6B	NUT – NYLOC M4 x 2mm ZINC	2	6612-03262
7	SCREW – PAN HEAD (M4x30) ZINC POZ	2	5750-565880
8	PROBE – HOPPER BOWL MOULDED	2	0961-567853
9	SCREW – TAPTITE M3 x 10 POSI	2	5762-07251
10	WASHER – FLAT M4 x 8 x 0.7	1	6626-04007
11	EARTH BRAID (Photo Optic Cover to Pawl Coin)	1	3109-563477
12	COVER – PHOTO OPTIC	1	0920-566779
13	SCREW	1	5762-07251
14	LOOM – PHOTO OPTIC HOPPER	1	3109-572157
15	BUSH – PHOTO OPTIC PCB SPACER	1	0707-07370
16	HOUSING – PHOTO OPTIC	1	0723-06085
17	COIN SLIDE – MOULDED	1	0743-567677
18	RETAINING CLIP	1	0736-567678
19	SCREW – PLASTITE – M4 x 9	2	5762-563249
20	SPRING	1	1004-567749
21	SCREW – PAN HEAD M5 x 32 POZI Z	4	5754-10653
22	SPRING - COMPRESSION	4	1001-01118
23	WASHER – FLAT M5 x 11 x 1	4	6626-04009
24	NUT – NYLOC – M5 ZINC	4	6612-07719
25	SCREW – TAPTITE PN HD M4 x 8	1	5762-564343
26	SPRING – FINGER HOPPER LATCH	1	1002-564375
27	LATCH – HOPPER PLATE – LOCKING	1	0937-564376
28	PLATE - HOPPER MOUNTING	1	2231-564254
29	HOPPER LOOM INTERFACE	1	3109-572312
30	SCREW – CHEESE HD. ZINC PL. M4x35	4	5748-02650
	WASHER – SPRING 5/32" int	4	6624-03884
31	BOLT – SHOULDER (COIN STIR)	1	0609-06076
32	COVER – SPRING	1	0713-06075
33	SPRING – COMPRESSION	1	6501-06325
34	STIRRER – COIN	1	0743-06074
35	SHELF - WHEEL	1	2130-579430
36	DISC	1	2001-07428
37	CHUTE – COIN EXIT	1	2214-573369
38	RUNNER – COIN	1	0639-17980
39	NUT HEX M6 ZINC	2	6610-03255
40	WASHER – SHAKEPROOF (1/4" I.D. BLK)	2	6623-03882
41	WASHER – FLAT (M6x11x1 ZINC)	2	6626-04010
42	SPRING - 2 nd . COIN WIPE-OFF	1	6501-07479
43	SCREW – TAPTITE M3 x 10 POSI	2	5762-07251
44	WASHER – FLAT – M3 x 6 x 1 ZINC	2	6626-04006
45	SCREW – M5 x 20	1	5753-02662
46	BUSH – DRIVE BOSS	1	0612-568259
47	COIN PAWL ASSEMBLY	1	2001-12516
48	SCREW – TAPTITE M3 x 10 POSI	2	5762-07251
49	SPRING - PAWL PRELOAD	1	1003-07371
50	WASHER - FLAT M5 x 11 x 1 ZINC	1	6626-04009
51	NUT – NYLOC M5 ZINC	1	6612-07719
52	SCREW – TAPTITE M3 x 10 POSI	2	5762-07251
53	BRACKET – ADH PHOTO OPTIC SHIELD	1	0913-564035
54	BEARING – 6 x 19 x 6 626 ZZ	1	5601-02491
55	BEARING – 6007 DDU	1	5601-02490
56	SPRING – BEARING AXLE ADH	1	6501-07369
57	PIN BEARING AXLE ADH	1	0633-07368



HOPPER

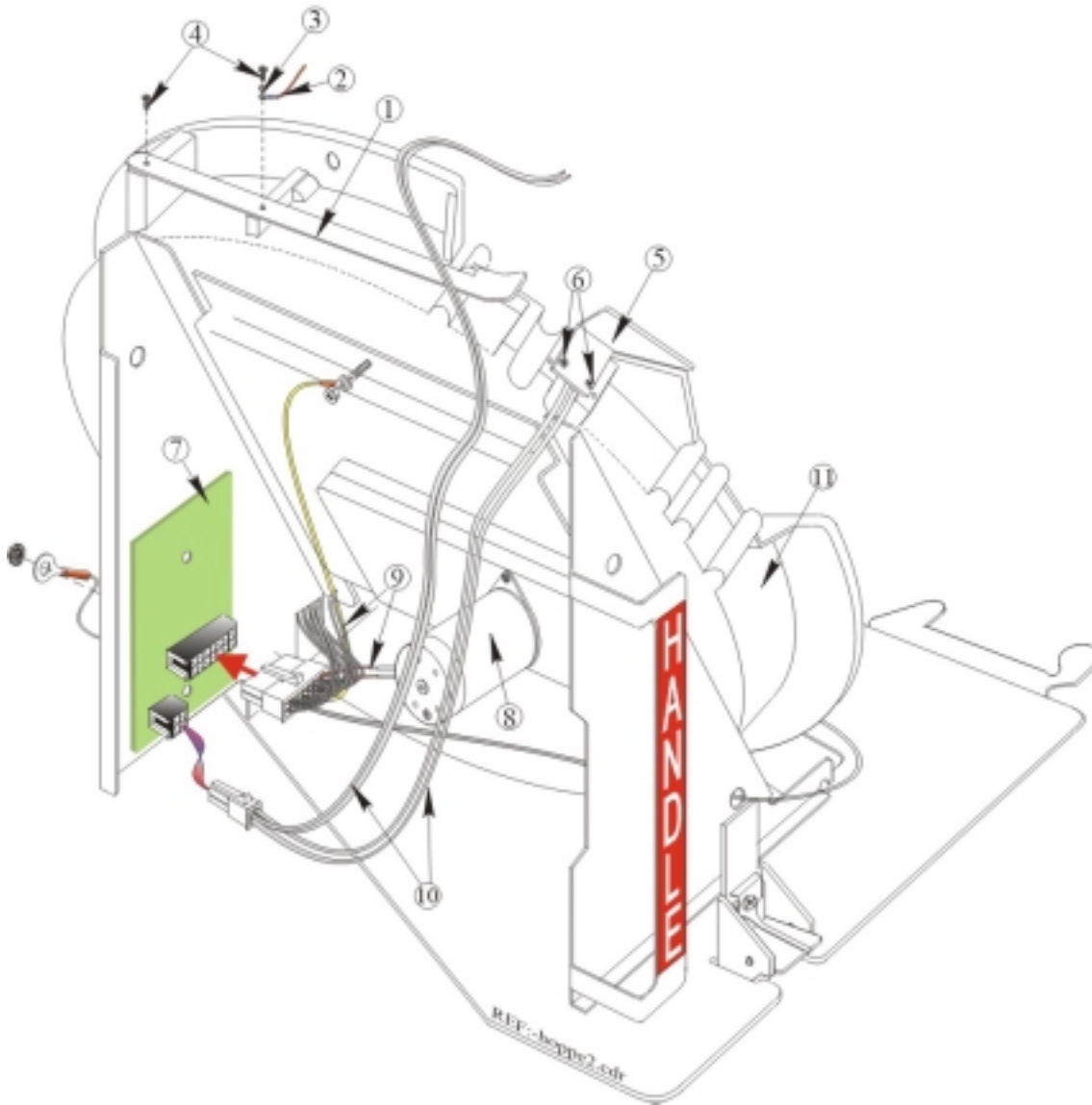

SECTION 5

HOPPERS AND COMPONENTS

REF No.	DESCRIPTION	QTY	PARTNo.
1	SPRING – PAWL PRELOAD	1	2001-12516
2	EARTH BRAID (Photo Optic Cover to Pawl Coin)	1	3109-563477
3	WASHER – FLAT M4 x 8 x 0.7	1	6626-04007
4	SCREW – TAPTITE M3 x 10 POSI	2	5762-07251
5	BRACKET – ADH PHOTO OPTIC SHIELD	1	0913-564035
6	SCREW – TAPTITE M3 x 10 POSI	2	5762-07251
7	PCBA ADH CONTROLLER	1	2501-410529
8	MOTOR & GEARBOX – 24Vdc BMG4023	1	6420-10871
9	LOOM ASSEMBLY – HOPPER INT AMP	1	3109-572312
10	LOOM ASSEMBLY – PHOTO OPTIC HOPPER	1	3109-572157
11	HOUSING – HOPPER	1	0313-07103



BRACKET-HOPPER

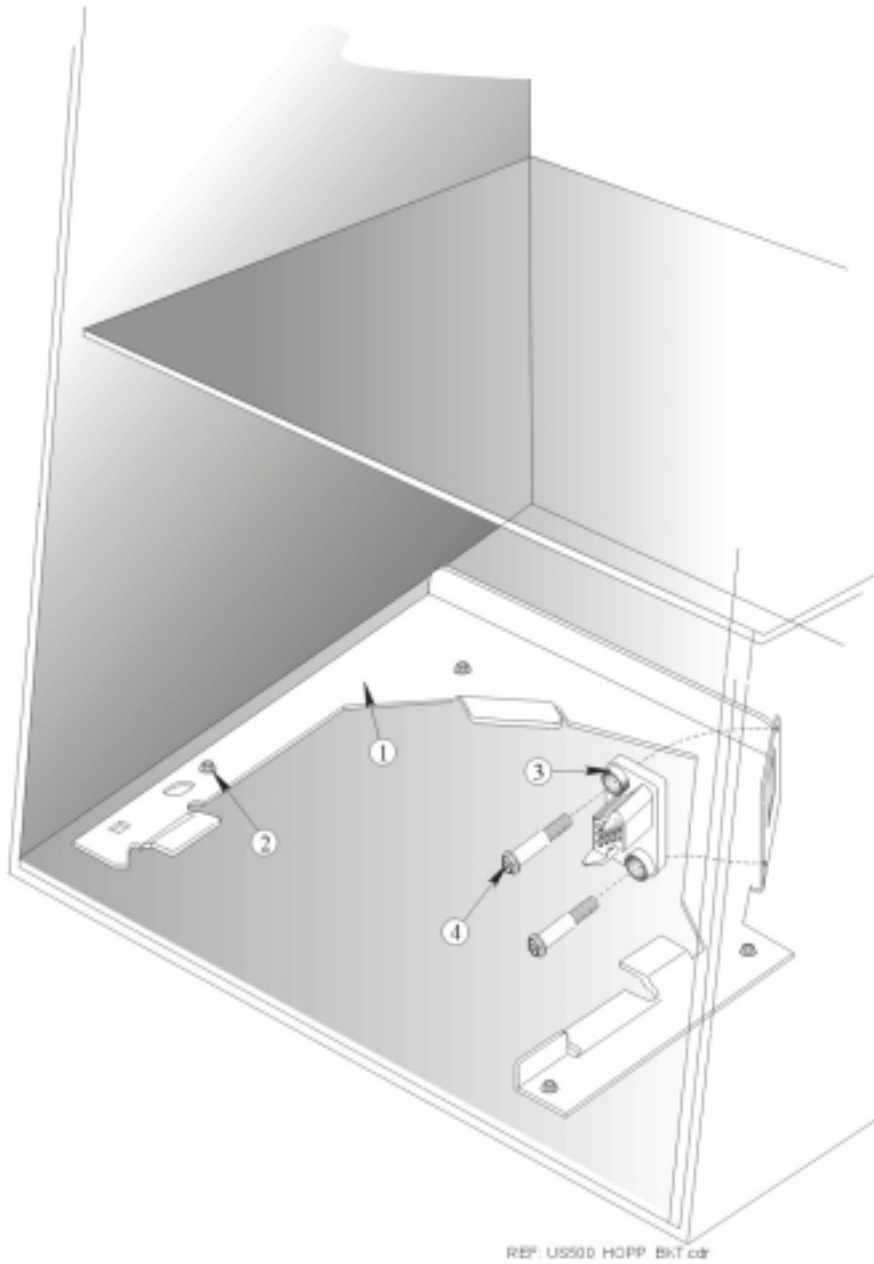

SECTION 5

HOPPERS AND COMPONENTS

REF No.	DESCRIPTION	QTY	PARTNo.
1	BRACKET – HOPPER	1	0913-564221
2	SCREW – HEX. HD. TAPTITE M5x12	4	5762-563051
3	LOOM - SOCKET	1	3109-565175
4	SCREW – SHOULDER AMP PLUG	2	5772-567282

SECTION 6

MAIN DOOR GENERAL COMPONENTS

MAIN DOOR

① DOOR ASSEMBLY

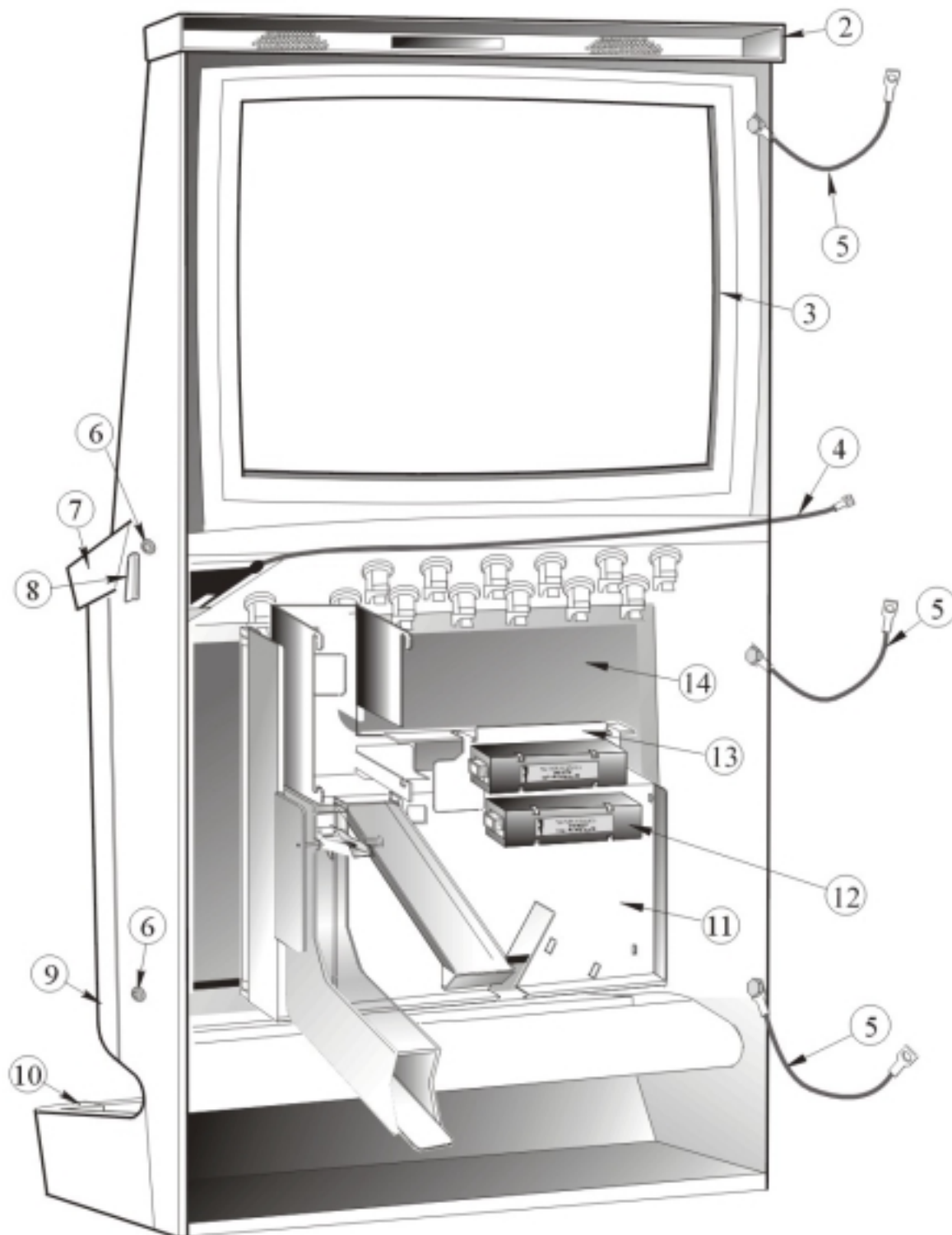

REF: MN_DR_US500.CDR



SECTION 6

MAIN DOOR GENERAL COMPONENTS

REF No.	DESCRIPTION	QTY.	PARTNo.
1	DOOR ASSEMBLY – MAIN	1	0001-572448
2	TOP TRIM	1	0958-572461
3	MASK - MONITOR	1	0728-572332
4	CABLE - DOOR SECURITY	1	1801-572483
5	LOOM ASSEMBLY BRAID EARTH LEAD	3	3109-563477
6	CAM – LARGE DOOR LATCH	2	0915-568751
	CAM – SMALL DOOR LATCH	2	0915-568752
	CAM – BELLY PANEL DOOR LATCH	1	0915-572491
	COVER – LATCH	1	0920-568754
	LINK – LATCH	1	0940-568763
	LINK – LATCH BELLY PANEL	1	0940-572489
	SPRING – LATCH	2	1004-571114
7	MID TRIM (Including Pushbutton Switches) - (Refer to Section 12)		
8	HANDLE – GRIP MAIN DOOR	1	0931-571788
9	BELLY PANEL DOOR ASSEMBLY	1	2219-572470
	STAY SPRING (Belly Panel Door) (Not Illustrated)	2	0952-565559
	EARTH KEAD BELLY PANEL (Not Illustrated)	1	3109-563477
	SWITCH (Cherry) BELLY PANEL (Not Illustrated)	1	6416-430795
	PANEL – BELLY PANEL ART BACKING	1	0501-572752
10	CHIP TRAY - (Refer to Section 11)		
11	REFLECTOR	1	0947-572315
12	BALLAST – FLUORO 6W	2	5501-430959
13	BRACKET – REFLECTOR BALLAST MOUNTING	1	0913-572714
14	MAT - ILLUMINATOR	1	0501-565247
15	LOOM - FLUORO SHORT (Not Illustrated)	1	3105-565750
	LOOM - FLUORO US (Not Illustrated)	1	3105-565534
	LOOM – FLUORO 24V	1	3105-565150



SECTION 7

COIN COMPARATOR & COIN CHUTE



REFLECTOR ASSEMBLY COIN COMPARATOR, and COIN CHUTE

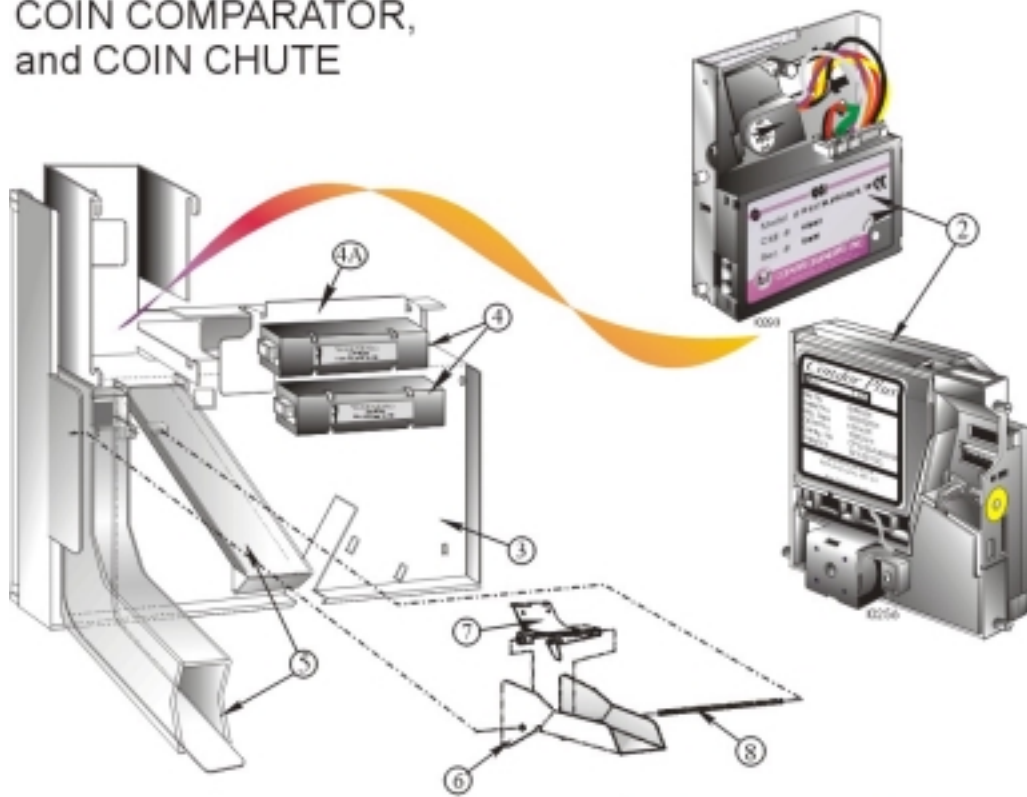

① REFLECTOR ASSEMBLY

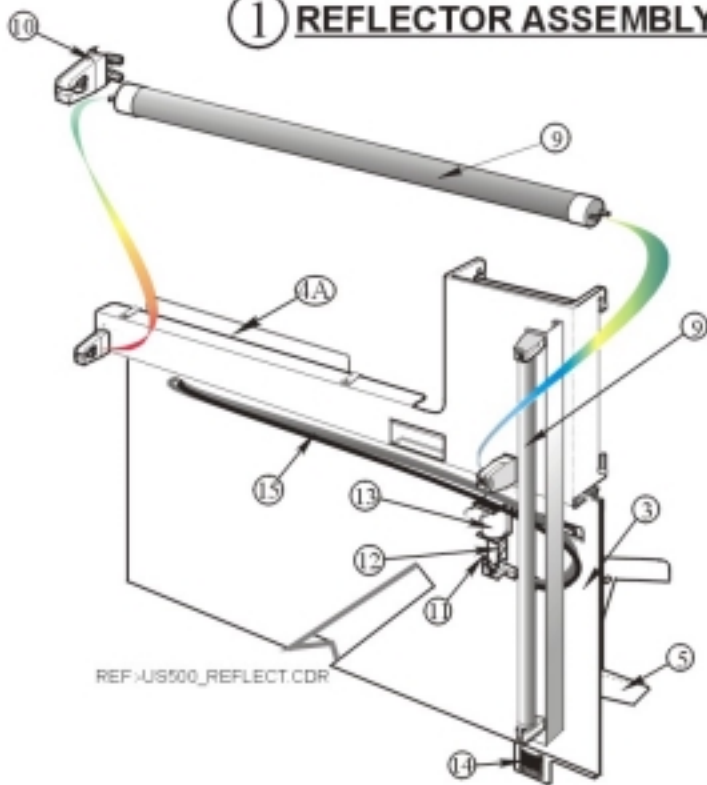

SECTION 7

COIN COMPARATOR
and
COIN CHUTE

REF No.	DESCRIPTION	QTY	PARTNo.
1	REFLECTOR ASSEMBLY	1	3316-572788_1
2	COIN VALIDATOR (CONDOR) USDO.05	1	6206-566365-12
	COIN VALIDATOR USDO.25	1	6206-566365-11
	COIN COMPARATOR (MC 62) (GENERIC)	1	0001-571730
3	REFLECTOR	1	0947-572315
4	BALLAST – FLUORO 6w	2	5501-430959
	COVER – BALLAST (Not Illustrated)	2	0713-565130
4A	BRACKET – REFLECTOR BALLAST MOUNTING	1	0913-572714
5	COIN CHUTE COVER	1	0710-565081
	NUT – KEPS - M4 ZINC	2	6604-51714
6	CHUTE – HOPPER FEED	1	0981-564841
7	DEFLECTOR ASSEMBLY	1	2217-564363
8	PIN – DEFLECTOR	1	0633-565241
9	TUBE - FLUORO	2	5506-03437
10	SOCKET – FLUORO TUBE	4	5504-430957
11	PIN, SPLIT (2.0mm x 12mm)	1	6635-564523
12	SPRING, SOLENOID	1	1001-564427
13	LOOM ASSEMBLY COIN DIVERSION & OPTIC SOLENOID	1	3114-565269
	BRACKET - SOLENOID	1	0913-566248
14	SPRING - COMPRESSION	2	0961-562039
15	LOOM - COIN DIVERter SOLENOID & OPTIC	1	3114-565269

SECTION 8

PANEL ART & DENOMINATION PATCHES



PANEL ART & PATCHES

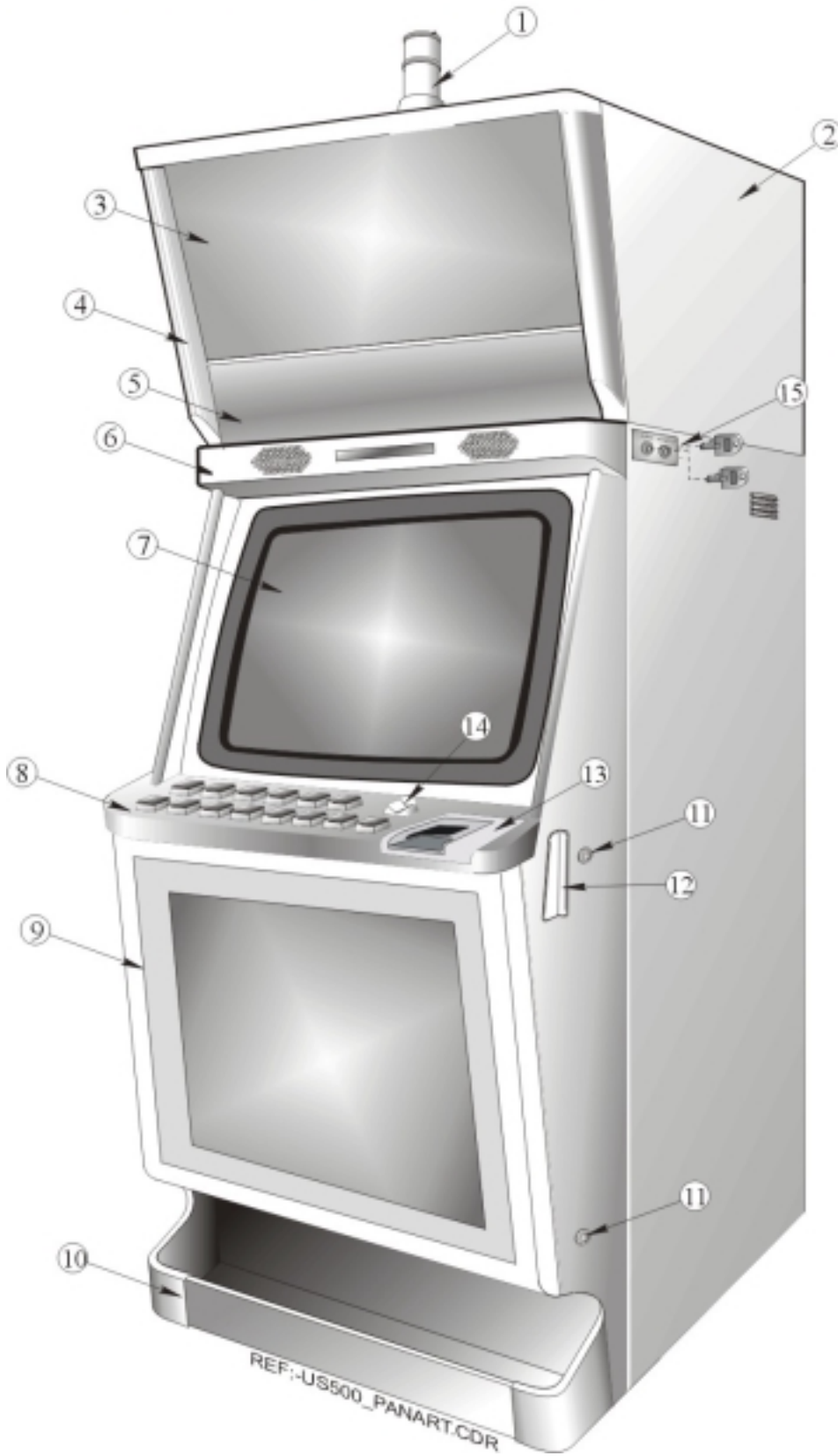

SECTION 8**PANEL ART & DENOMINATION PATCHES**

REF No.	DESCRIPTION	QTY	PART No.
1	LIGHT TOWER ASSEMBLY - (Refer to Section 9)		
2	TOP BOX ASSEMBLY –CASINO - (Refer to Section 3)		
	WRAP – CASINO TOP Box - (Refer to Section 3)		
3	ARTWORK BACKING 2mm - TOP BOX DOOR	1	0507-572511_28
4	BRACKETS – DOOR CASINO ART - (Refer to Section 3)		
5	BRACKET – DOOR BOTTOM - (Refer to Section 3)		
6	TOP TRIM - (Refer to Section 6)		
7	MONITOR (Refer to Section 4)		
8	PUSHBUTTONS & TRIM (Refer to Section 12)		
9	BELLY PANEL DOOR ASSEMBLY - (Refer to Section 6)		
10	CHIP TRAY COMPONENTS (Refer to Section 11)		
11	DOOR LOCKING COMPONENTS (Refer to Section 14)		
12	HANDLE - (Refer to Section 6)		
13	BILL ACCEPTOR ENTRY (Refer to Section 12)		
14	COIN ENTRY (Refer to Section 12)		

SECTION 9

LIGHT TOWER



**NOTE:-
THIS IS A TYPICAL LIGHT TOWER ASSEMBLY ONLY.**

1 LIGHT TOWER ASSEMBLY

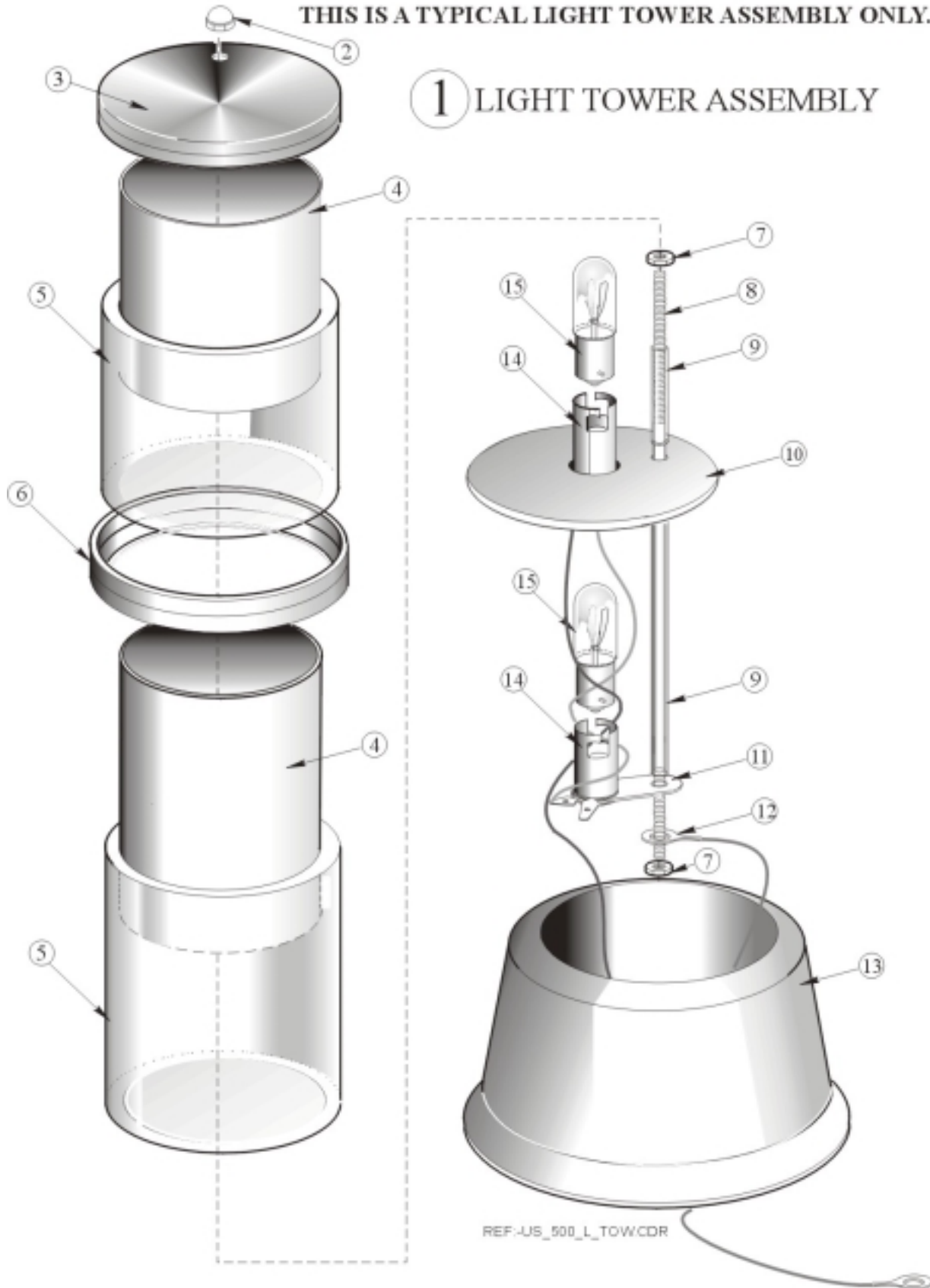

SECTION 9

LIGHT TOWER

REF No.	DESCRIPTION	QTY	PARTNo.
---------	-------------	-----	---------

NOTE :- This Is A Typical Light Tower Assembly Only

NOTE:- LOOM ASSEMBLY, AVAILABLE WITHIN LIGHT TOWER ASSEMBLY KIT ONLY.



SECTION 10

BANK NOTE ACCEPTOR CAGE AND COMPONENTS



BANK NOTE ACCEPTOR, CAGE & COMPONENTS

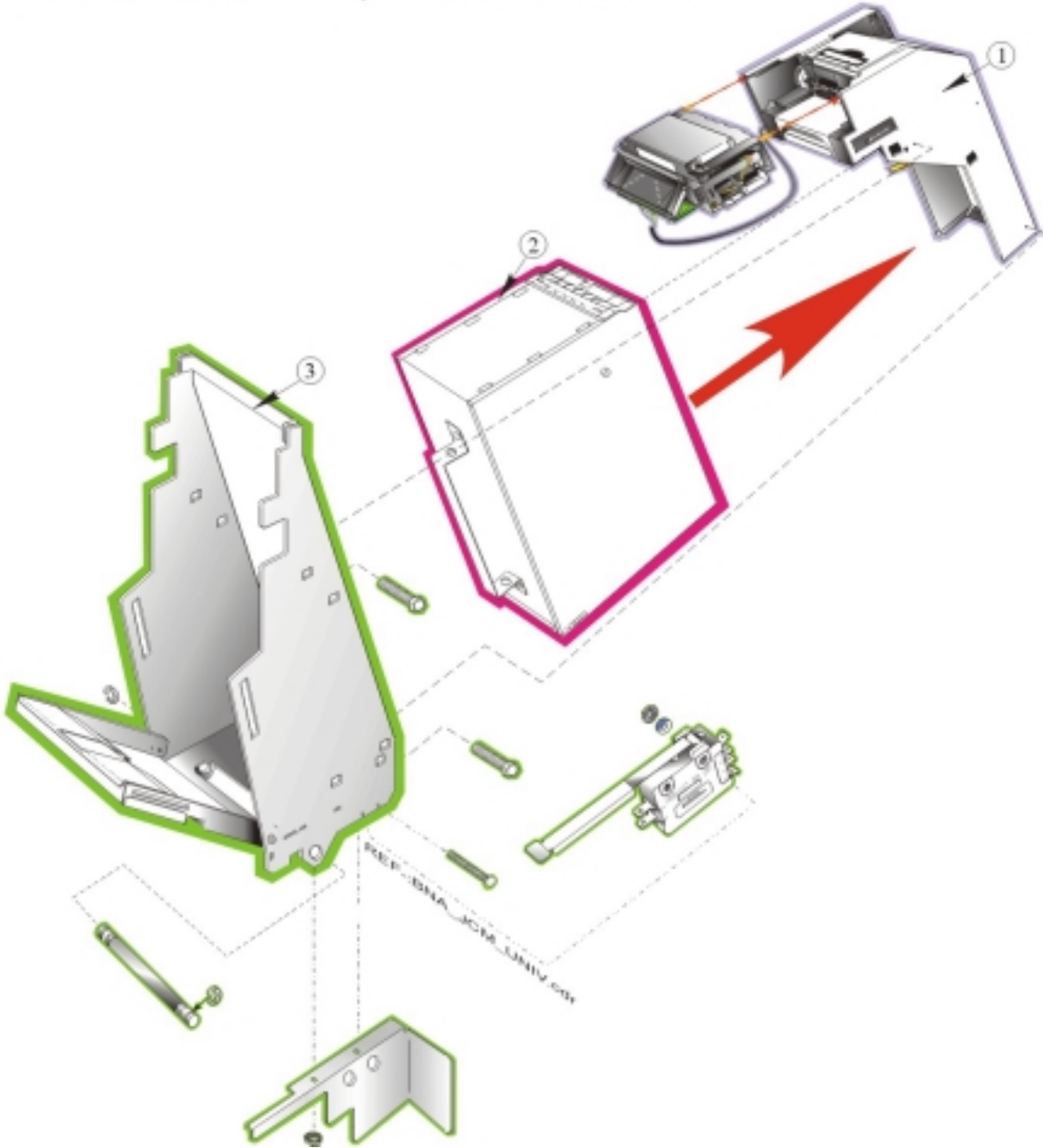

SECTION 10

BANK NOTE ACCEPTOR CAGE & COMPONENTS

REF No.	DESCRIPTION	QTY	PARTNo.
1	BANK NOTE ACCEPTOR (JCM) USA	1	6217-571695_2
2	STACKER (JCM) USA (CASHBOX)	1	6218-571725_2
3	BNA CAGE ASSEMBLY – UNIVERSAL (Includes Security Switch)	1	3316-571331

BANK NOTE ACCEPTOR, CAGE & COMPONENTS

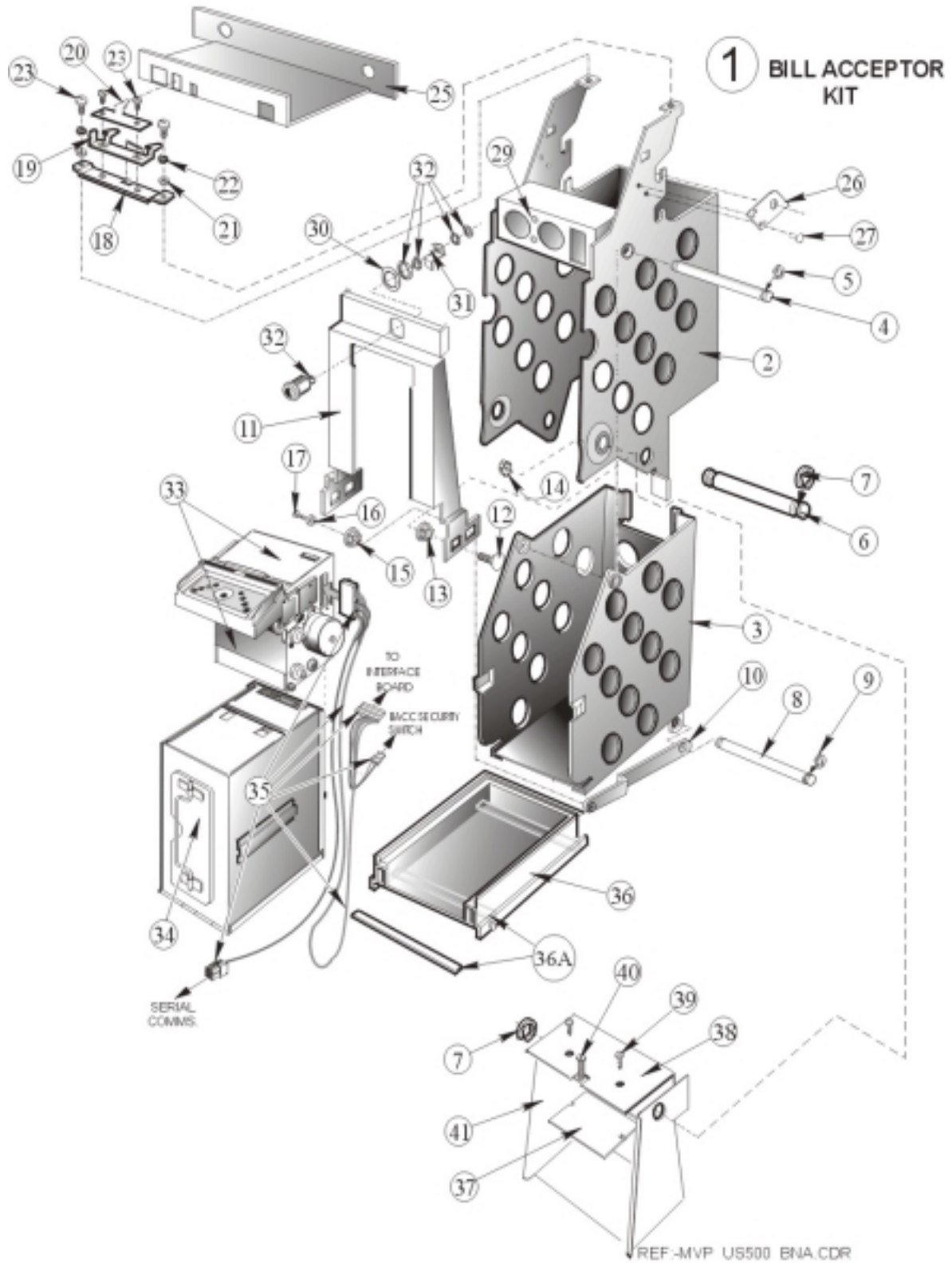

SECTION 10

BILL ACCEPTOR
CAGE & COMPONENTS

REF No.	DESCRIPTION	QTY	PARTNo.
1	KIT BILL ACCEPTOR (CONSISTS OF ITEMS 2 to 29 INCLUSIVE)	1	3316-565251-2
2	CAGE ASSEMBLY,WELDED	1	2246-566798
3	CRADLE, STACKER	1	0963-561737
4	PIN, CRADLE PIVOT	1	0633-561646
5	E-CIRCLIP 8mm (Anderton)	2	6627-561902
6	PIN, CAGE PIVOT	1	0633-561722
7	E-CIRCLIP 12mm (Anderton)	2	6627-561903
8	PIN, CRADLE PIVOT	1	0633-561646
9	E-CIRCLIP 8mm (Anderton)	2	6627-561902
10	LINK, PIVOT MECHANISM	1	0940-561647
11	DOOR ASSEMBLY – SINGLE LOCK	1	0923-567603-1
	DOOR ASSEMBLY – DOUBLE LOCK	1	0923-567603-2
12	SCREW, GUARD PIVOT	2	0604-561721
13	BUSH, PIVOT	2	0707-561719
14	NUT, KEP S ZINC PL. M5	2	6604-51713
15	BUSH, LINK	2	0707-561720
16	WASHER, FLAT ZINC PL. 1/8" x 3/8" OD	4	6622-03855
17	SCREW, PAN HD. ZINC PL. M3 x 5	4	5746-02640
18	BRACKET, BILL ACCEPTOR CAGE TOP	1	0913-562989
19	LATCH, BILL ACCEPTOR INTERLOCKING	1	0937-563375
20	BRACKET, STOP	1	0913-564859
21	WASHER, FLAT ZINC PL. M4.2 x 8 x 0.7 THICK	6	6622-03855
22	WASHER, SHAKEPROOF ZINC PL. 1/8" ID	2	6623-562924
23	SCREW, PAN HD. ZINC PL. M3 x 8	2	5746-11784
24	SPRING, EXTENSION	1	1004-562990
25	BRACKET BILL ACCEPTOR LOCATION	1	0913-564823
26	CLIP – VALIDATOR RETAINING	2	0919-565275
27	RIVET, BLIND 3.2 DIA	4	6637-03916
28	CLIP, BACC LOCK (Not Illustrated)	1	0919-566795
29	RIVET, BLIND 3.2 DIA	2	6637-03916
30	WASHER, SHAKEPROOF BLACK. 3/4"	1/LOCK	6623-03883
31	CAM, BILL ACCEPTOR LOCK	1/LOCK	0915-565287
32	LOCK (Quantity Option 1 or 2 and Lock Type as per Customer Requirements)	A/R	-
33	BILL VALIDATOR - STD - USA	1	6217-564516-11
34	STACKER, SRC std – SINGLE HOLE	1	6218-562007-11
NOTE:- ITEM 34 IS FITTED WITH THE FOLLOWING 2 SECURITY COMPONENTS:-			
-	LOCK, (Not Illustrated, Mounted into Base of Stacker)	1	-
-	CAM, KEY LOCK (Not Illustrated, Fitted to Lock)	1/LOCK	0915-565287
35	LOOM ASSEMBLY INTERFACE BOARD TO BILL ACCEPTOR	1	3109-565649
36	STACKER BASE	1	0703-561955
36A	SPRING FLAT, BILL ACCEPTOR CRADLE BASE	2	0703-561915
37	PLATE, ADJUSTER	1	0945-566250
38	PLATE, LOCKING	1	0945-564288
39	SCREW, HEX HD.TAPTITE, ZINC PL. M5 x 12	2	5762-563051
40	GRUB SCREW, M5 x 16	1	5761-562986
41	BRACKET, BILL ACCEPTOR, MOUNTING (PART OF MAIN CABINET)	1	2211-564816
42	BRACKET SECURITY (Not Illustrated)	1	0913-568062



SECTION 11
CHIP TRAY, COMPONENTS
FOR MAIN DOOR



CHIP TRAY COMPONENTS

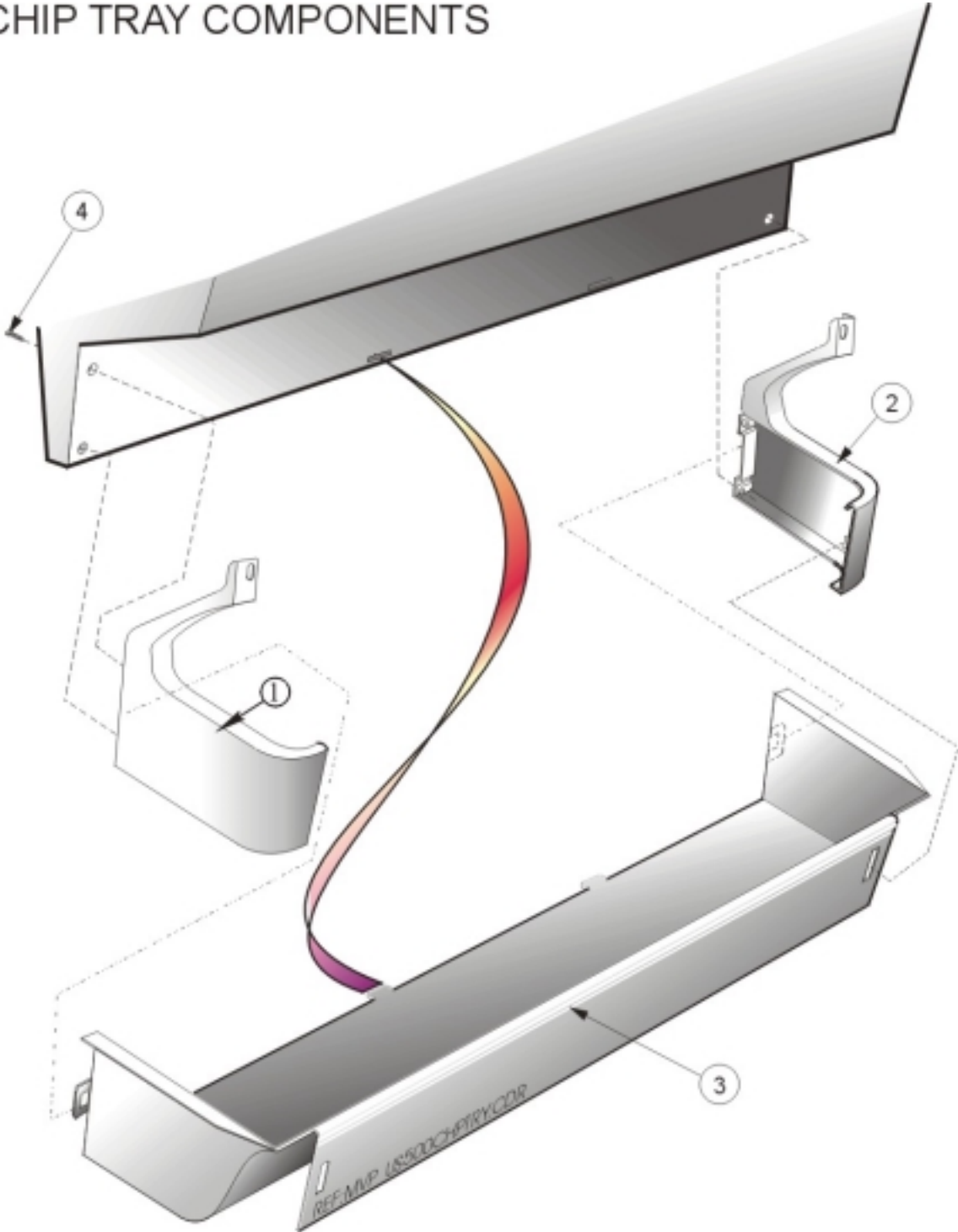

SECTION 11

CHIP TRAY, COMPONENTS FOR MAIN DOOR

REF No.	DESCRIPTION	QTY	PARTNo.
1	END CAP OUTER CHIP TRAY - L.H.BRIGHT CHROME	1	0303-572331_101
	END CAP OUTER CHIP TRAY - L.H.BRIGHT GOLD	1	0303-572331_102
	END CAP OUTER CHIP TRAY - L.H.SATIN CHROME	1	0303-572331_104
	END CAP OUTER CHIP TRAY - L.H.SATIN GOLD	1	0303-572331_105
	END CAP OUTER CHIP TRAY - L.H.BLACK ONYX	1	0303-572331_106
	END CAP OUTER CHIP TRAY - L.H.BLACK SATIN	1	0303-572331_136
2	END CAP OUTER CHIP TRAY - R.H.BRIGHT CHROME	1	0303-572331_201
	END CAP OUTER CHIP TRAY - R.H.BRIGHT GOLD	1	0303-572331_202
	END CAP OUTER CHIP TRAY - R.H.SATIN CHROME	1	0303-572331_204
	END CAP OUTER CHIP TRAY - R.H.SATIN GOLD	1	0303-572331_205
	END CAP OUTER CHIP TRAY - R.H.BLACK ONYX	1	0303-572331_206
	END CAP OUTER CHIP TRAY - R.H.BLACK SATIN	1	0303-572331_236
3	TRAY - CHIP	1	0957-572517
4	SCREW - TAPTITE - M5 x 12 HEX HD.	6	5762-563051



SECTION 12
MID TRIM ASSEMBLY
including
BANK NOTE ACCEPTOR ESCUTCHEON
COIN ENTRY
and
PUSHBUTTON SWITCH TRIM

BANK NOTE ACCEPTOR / COIN ENTRY and PUSH BUTTON SWITCH TRIM

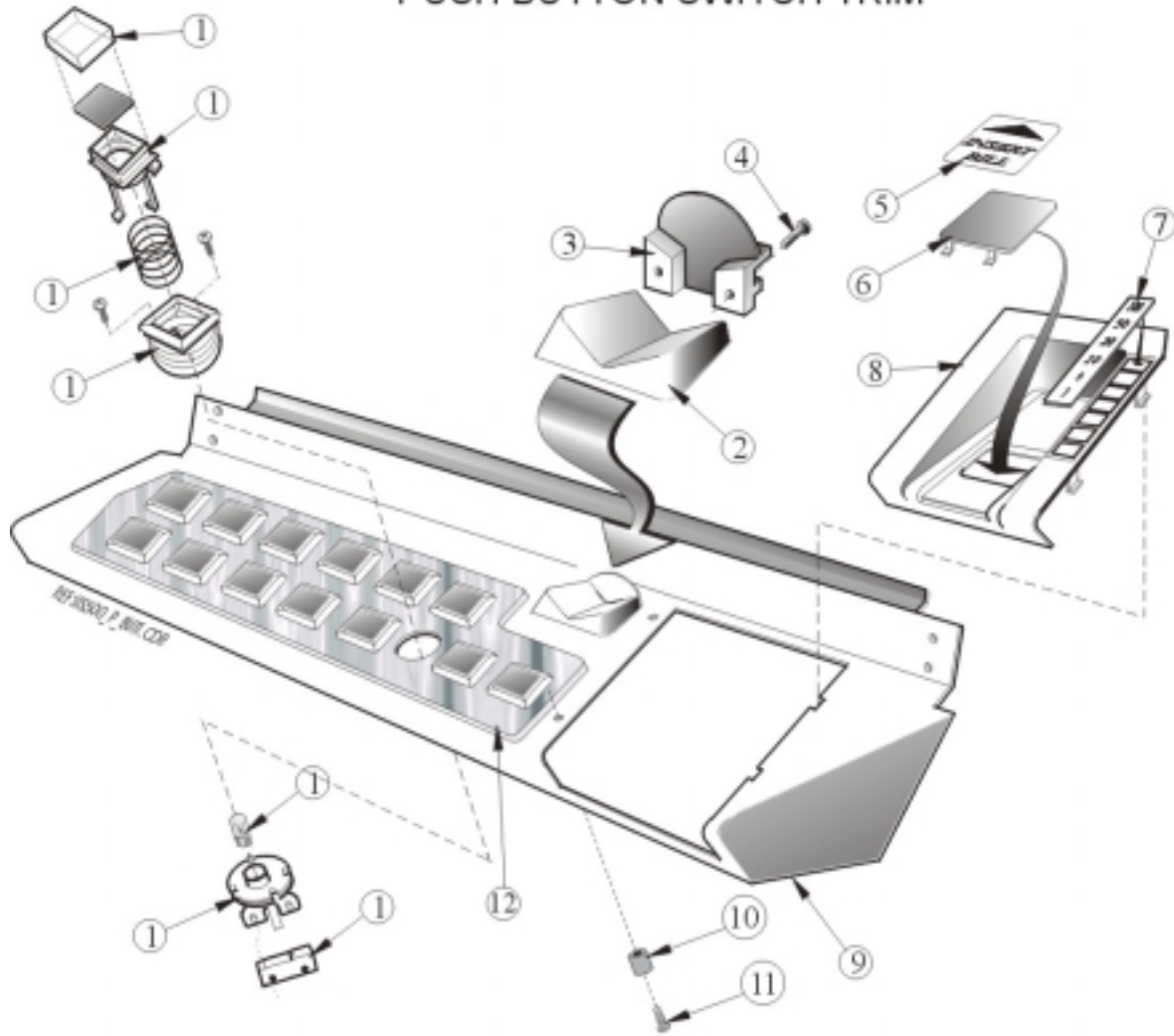

* NOTE:- Items 1 with 2 are a complete assembly.

SECTION 12
MID TRIM ASSEMBLY
Including
BANK NOTE ACCEPTOR / COIN ENTRY
and
PUSHBUTTON SWITCH TRIM

REF No.	DESCRIPTION	QTY	PART No.
1	PUSHBUTTON ASSEMBLY	14	6416-430744
2	BODY - COIN ENTRY - CHROME	1	0320-565059-1
	BODY - COIN ENTRY - GOLD	1	0320-565059-2
3	BACKPLATE - COIN ENTRY - CHROME	1	0320-565058-18-1
	BACKPLATE - COIN ENTRY - GOLD	1	0320-565058-18-2
4	SCREW - PAN HD - M4 x 12 ZINC	2	5750-02655
5	DECAL - BILL ACCEPTOR - INSERT BILL	1	0122-567376-2
6	INSERT - BILL ACCEPTOR	1	0724-564853
7	DECAL - BILL ACCEPTOR DENOM	1	0122-567375-4
8	ESCUTCHEON - BILL ACCEPTOR ENTRY - CHROME	1	0320-564854-1
	ESCUTCHEON - BILL ACCEPTOR ENTRY - GOLD	1	0320-564854-2
9	MID TRIM - 14 PUSHBUTTON (Bright Chrome)	1	2241-572463_01
	MID TRIM - 14 PUSHBUTTON (Bright Gold)	1	2241-572463_02
	MID TRIM - 14 PUSHBUTTON (Satin Chrome)	1	2241-572463_04
	MID TRIM - 14 PUSHBUTTON (Satin Gold)	1	2241-572463_05
	MID TRIM - 14 PUSHBUTTON (Black Onyx)	1	2241-572463_06
	MID TRIM - 14 PUSHBUTTON (Black Satin)	1	2241-572463_02
10	BUSH - ESCUTCHEON	2	0612-565117
11	SCREW - PAN HD - M3 x 5 ZINC	2	5750-02654
12	PANEL - MID TRIM (Bright Chrome)	1	0944-572469_0101
	PANEL - MID TRIM (Bright Gold)	1	0944-572469_0102
	PANEL - MID TRIM (Satin Chrome)	1	0944-572469_0104
	PANEL - MID TRIM (Satin Gold)	1	0944-572469_0105
	PANEL - MID TRIM (Black Onyx)	1	0944-572469_0106
	PANEL - MID TRIM (Black Satin)	1	0944-572469_0136
13	LOOM ASSEMBLY - 4 SMALL P/B (Not Illustrated)	1	3122-572289
14	LOOM ASSEMBLY - 10 SMALL P/B (Not Illustrated)	1	3122-572288



SECTION 13

DOOR HINGES and COMPONENTS

DOOR HINGES

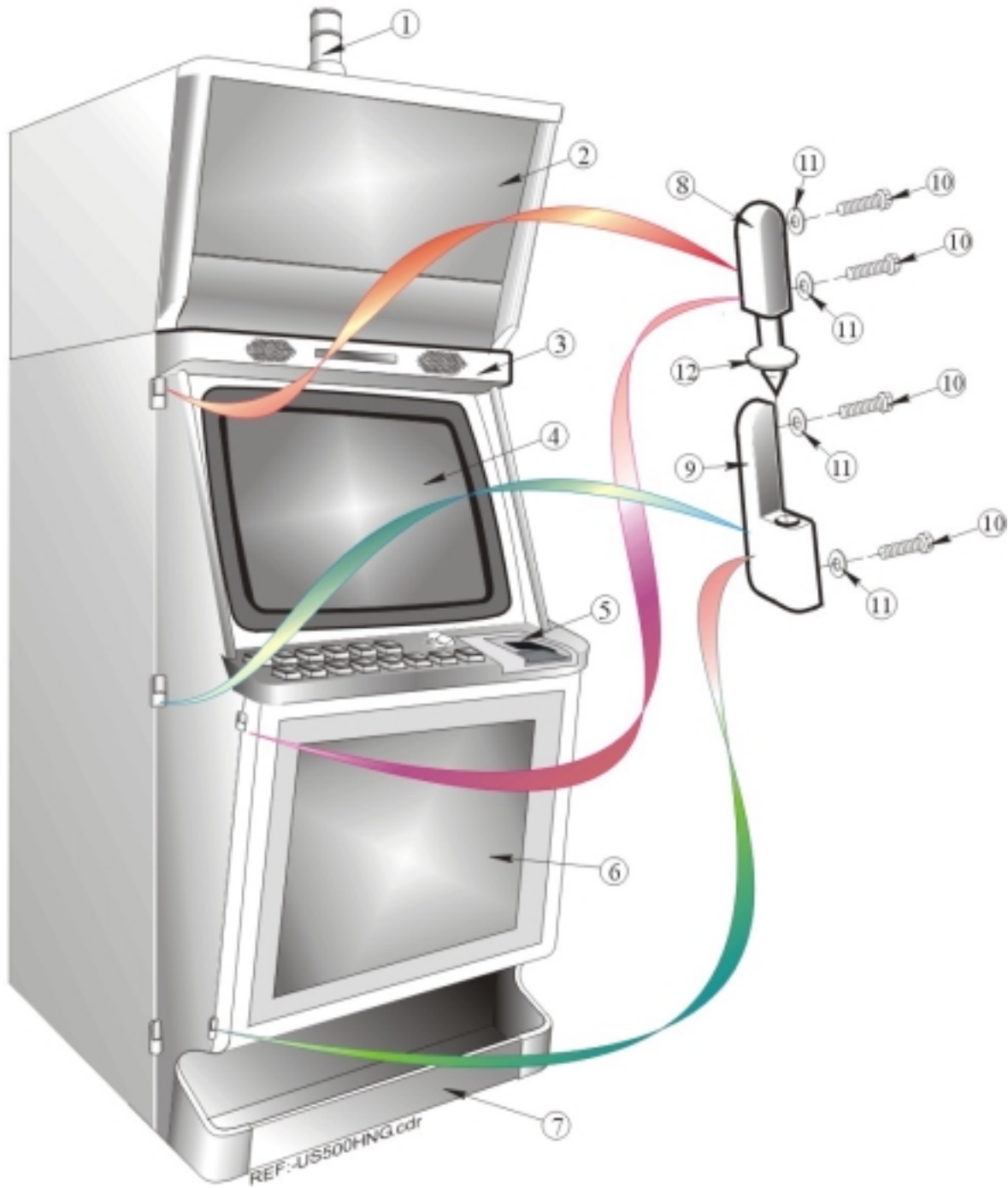

SECTION 13
DOOR HINGES
and
COMPONENTS

REF No.	DESCRIPTION	QTY	PARTNo.
1	LIGHT TOWER – (Refer to Section 9)		
2	ARTWORK – TOP BOX (Refer to Section 8)		
3	TOP TRIM – DOOR (Refer to Section 6)		
4	MONITOR ASSEMBLY (Refer to Section 4)		
5	MID TRIM ASSEMBLY (Refer to Section 12)		
6	BELLY PANEL DOOR (Refer to Section 8, 6 & 14)		
7	CHIP TRAY ASSEMBLY (Refer to Section 11)		
8	HINGE – MAIN DOOR – (Male U.S. Chrome)	3	0320-564494_1
	HINGE – MAIN DOOR – (Male U.S. Gold)	3	0320-564494_2
	HINGE – MAIN DOOR – (Male U.S. Painted)	3	0320-564494_3
	HINGE – BELLY PANEL DOOR – (Male US Chrome)	2	0320-562070_1
	HINGE – BELLY PANEL DOOR – (Male US Gold)	2	0320-562070_2
9	HINGE – MAIN DOOR – (Female U.S. Chrome)	3	0320-564493_1
	HINGE – MAIN DOOR – (Female U.S. Gold)	3	0320-564493_2
	HINGE – MAIN DOOR – (Female U.S. Painted)	3	0320-564493_3
	HINGE – BELLY PANEL DOOR – (Female US Chrome)	2	0320-562071_1
	HINGE – BELLY PANEL DOOR – (Female US Gold)	2	0320-562071_2
10	SCREW –TAPTITE - M5 x 12 - HEX HD (Main Door)	12	5762-563051
	SCREW – M4 x 8 – POZI ZC (Belly Panel Door)	8	5750-564342
11	WASHER - S/P 3/16” EXT 9 SPOKE (Main Door)	12	6623-562922
	WASHER - (Belly Panel Door)	8	6623-03880
12	WASHER - HINGE BEARING (Main Door)	3	6626-562079
	WASHER - HINGE BEARING (Belly Panel Door)	2	6626-562065



SECTION 14

DOOR LOCKING COMPONENTS

DOOR LOCKING COMPONENTS

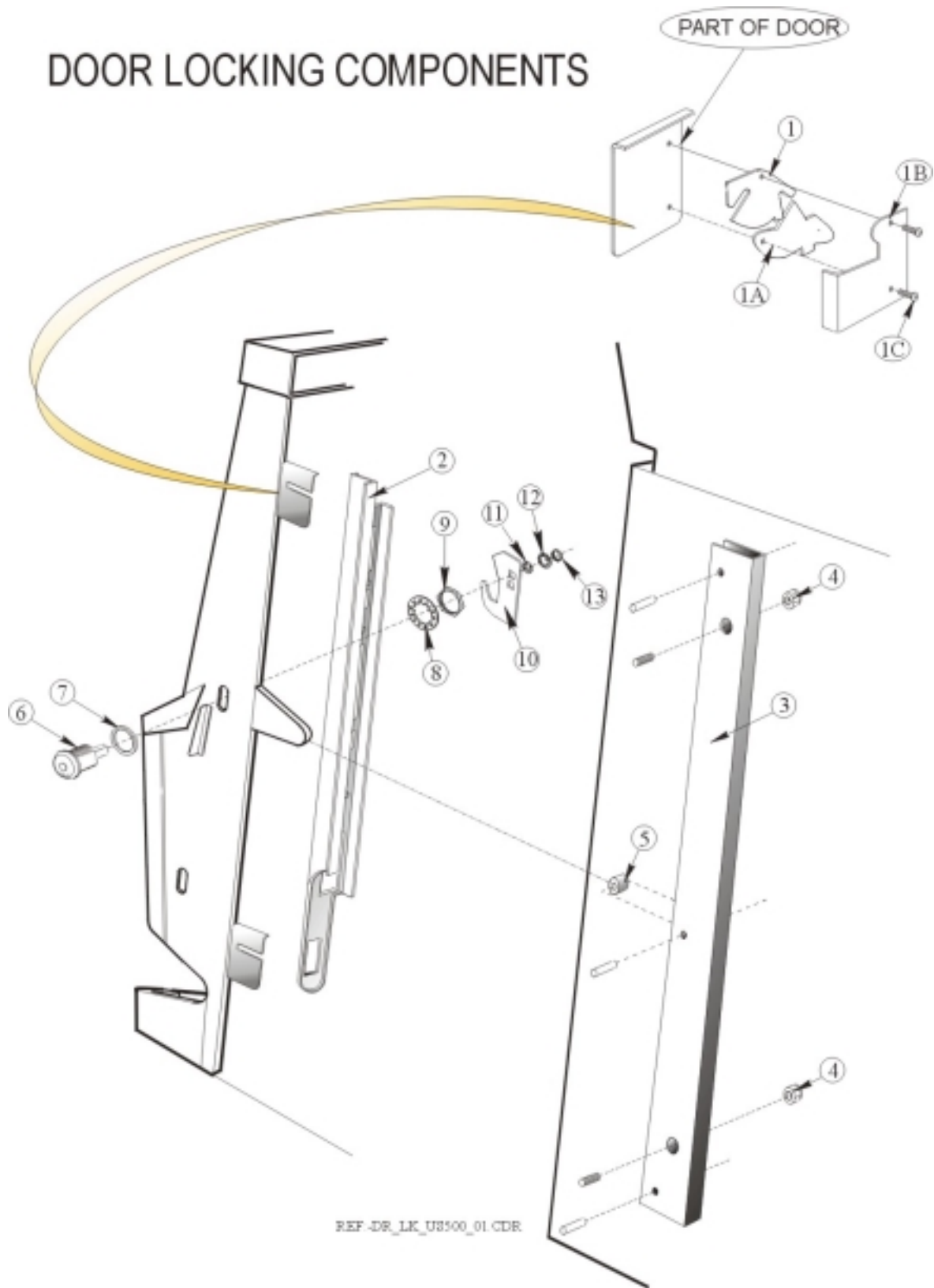

SECTION 14**DOOR LOCKING COMPONENTS**

REF No.	DESCRIPTION	QTY	PART No.
1	CAM – LARGE DOOR LATCH	2	0915-568751
1A	CAM – SMALL DOOR LATCH	2	0915-568752
1B	COVER – LATCH	1	0920-568754
1C	SCREW – BUTTON HEAD SKT. M4 x 8	4	5772-571623
2	LINK – LATCH ASSEMBLY	1	0940-568763
3	BRACKET DOOR LATCH	1	0913-568762
4	NUT – NYLOC M5 ZINC (Bracket to Cabinet)	2	6604-51713
5	ROLLER – DOOR LATCH	1	0638-568755
6	LOCK – (As Fitted)	1	5608-03287
7	SPACER – LOCK	1	0648-568756
8	WASHER - SHAKEPROOF BLACK - LARGE	1	6623-03883
9	NUT – HEX LARGE	1	5608-14306
10	CAM - LOCK	1	0915-568753
11	ADAPTER – CAM	1	0902-568060
12	WASHER – SHAKEPROOF SMALL	1	6623-03877
13	NUT – (lock)	1	5608-14307
14	SPRING – LATCH (Not Illustrated)	1	1004-571114

DOOR LOCKING COMPONENTS

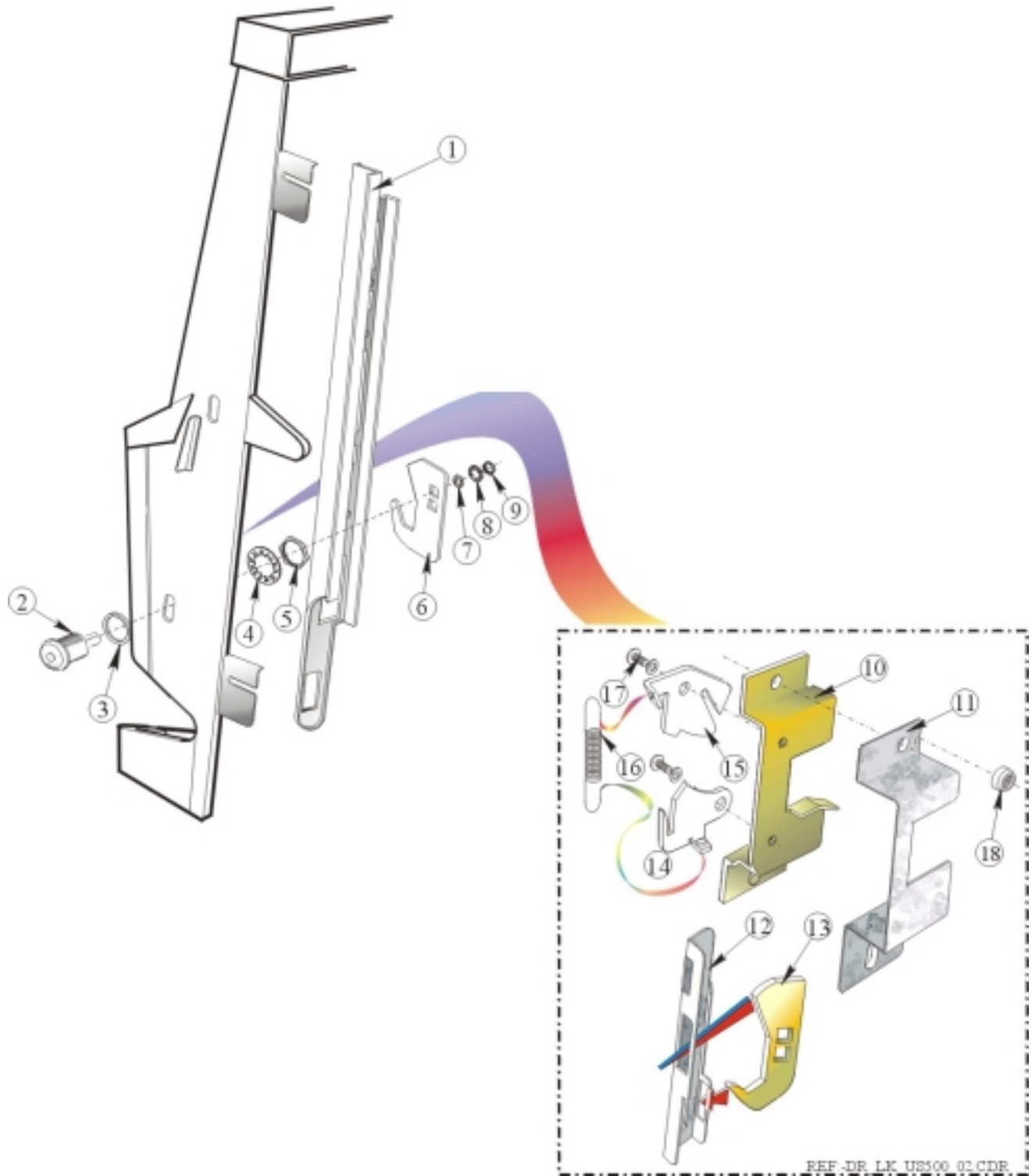

SECTION 14**DOOR LOCKING COMPONENTS**

REF No.	DESCRIPTION	QTY	PART No.
1	LINK – LATCH ASSEMBLY	1	0940-568763
2	LOCK – (As Fitted)	2	5608-03287
3	SPACER – LOCK	2	0648-568756
4	WASHER - SHAKEPROOF BLACK - LARGE	2	6623-03883
5	NUT – HEX LARGE	2	5608-14306
6	CAM - LOCK	2	0915-568753
7	ADAPTER – CAM	1	0902-568060
8	WASHER – SHAKEPROOF SMALL	2	6623-03877
9	NUT – (lock)	2	5608-14307
10	BRACKET – B/DOOR LATCH	1	0913-572490
11	CLAMP – B/DOOR LATCH	1	0961-572481
12	LINK – B/DOOR LATCH	1	0940-572489
13	CAM - LOCK	1	0915-568753
14	CAM – B/DOOR LATCH	1	0915-572491
15	CAM – LARGE	1	0915-568751
16	SPRING – LATCH	1	1004-571114
17	SCREWS M4 x 8	8	5750-564342
18	NUT – NYLOC M5 ZINC	3	6612-07719

SECTION 15

SPEAKER HOUSING ASSEMBLY
&
HARD METERS ASSEMBLY

SPEAKER/AMPLIFIER HOUSING ASSEMBLY and HARD METER ASSEMBLY

① SPEAKER/AMPLIFIER HOUSING ASSEMBLY 572794_1

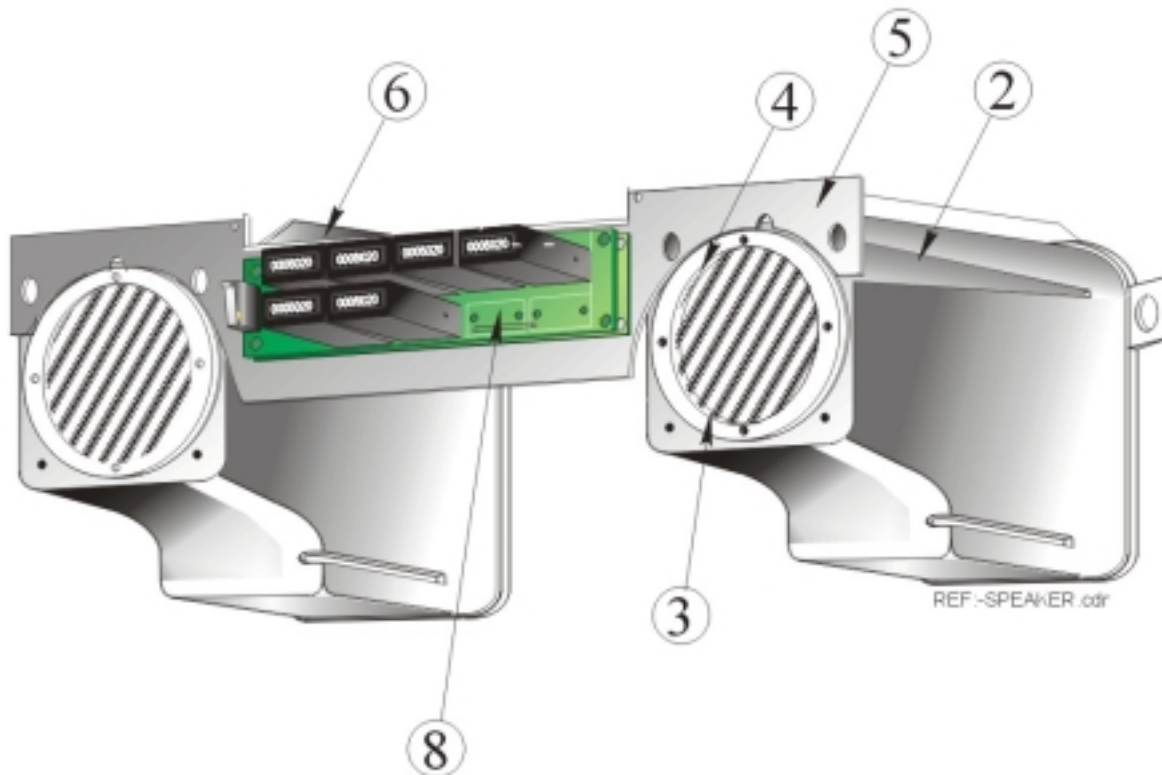

⑦ METER KIT ASSEMBLY 572793_1

SECTION 3**TOP BOX
GENERAL COMPONENTS**

REF No.	DESCRIPTION	QTY	PARTNo.
1	SPEAKER/AMPLIFIER HOUSING ASSEMBLY	1	3316-572794_1
2	HOUSING – SPEAKER BOX	2	0723-572365
3	SPEAKER ASSEMBLY	2	3120-572284
	SCREW – PLASTITE 45 M3.5 x 10 (Not Illustrated)	16	5762-572803
	SCREW – PLASTITE 45 M4 x 16 (Not Illustrated)	4	5762-572804
4	COVER – SPEAKER BOX	2	0713-572366
	LOOM VOLUME CONTROL (Not Illustrated)	1	3120-572377
5	BRACKET – METER & SPEAKER MOUNTING	1	0913-572728
6	PCBA – AUDIO AMPLIFIER	1	2501-410539
	SCREW – M3 x 10 PCBA to BRACKET (Not Illustrated)	5	5746-566696
	LOOM – BACKPLANE to AMPLIFIER SPEAKER SIGNAL (Not Illustrated)	1	3109-572287
7	METER KIT ASSEMBLY	1	3316-572793_1
8	HMB 6 METERS ASSEMBLY	1	2501-572391
	COVER – METER (Not Illustrated)	1	0920-572716
	SPRING – Hard Meter COVER (Not Illustrated)	1	1002-568865
	LABEL – METERS (Not Illustrated)	1	4503-566734
	NUT KEPS M3 ZINC (Cover to Plate) (Not Illustrated)	1	6602-561325
	LOOM – METERS SWITCH INPUT (Not Illustrated)	1	3109-568859



SECTION 16

LOOM ASSEMBLY
for
CABINET DOOR & REFLECTOR



Looms for Cabinet Door & Reflector

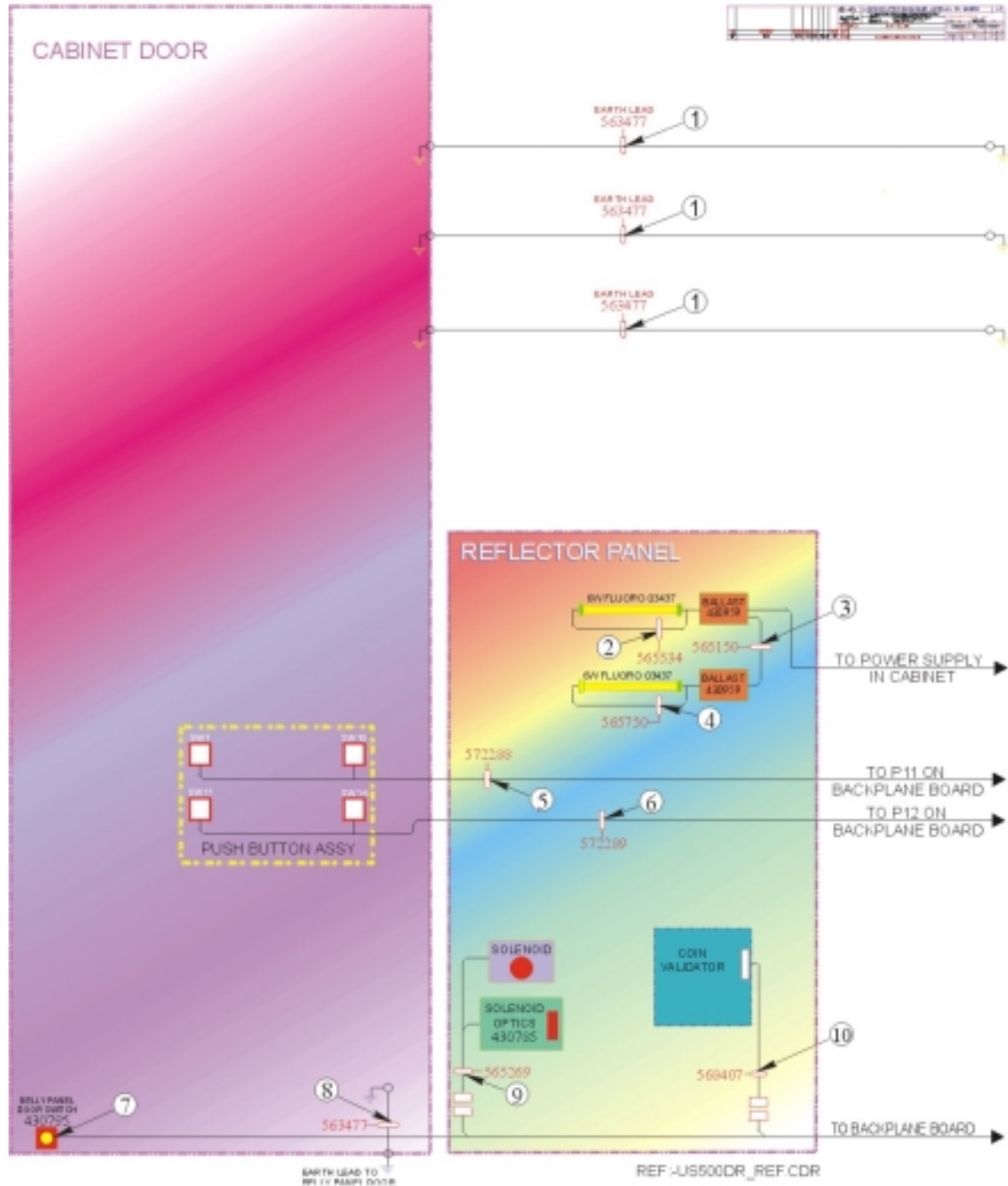

LOOM ASSEMBLY
for
CABINET DOOR
and
REFLECTOR

REF No.	DESCRIPTION	QTY	PARTNo.
1	LOOM ASSEMBLY - BRAID EARTH LEAD	3	3109-563477
2	LOOM ASSEMBLY – FLUORO to BALLAST	1	3105-565534
3	LOOM ASSEMBLY – DAISY FLUORO DOOR	2	3105-565150
4	LOOM ASSEMBLY – FLUORO SHORT	1	3105-565750
5	LOOM ASSEMBLY - 10 PUSHBUTTONS	1	3122-572288
6	LOOM ASSEMBLY - 4 PUSHBUTTONS	1	3122-572289
7	SWITCH – CHERRY E78-00A	1	6416-430795
8	LOOM ASSEMBLY - BRAID EARTH LEAD	1	3109-563477
9	LOOM ASSEMBLY – COIN DIVERSION & OPTIC SOLENOID	1	3114-565269
10	LOOM ASSEMBLY – Connects CONDOR To Trunk Loom.	1	3109-568407

SECTION 17

LOOM ASSEMBLY
for
CABINET
&
TOP BOX



Looms for Cabinet & Top Box

NOTE 1: DOOR SWITCH CONNECTIONS

MAIN DOOR		REPLY DOOR		CASHBOX SWITCH		SECOND DR. SW.		BILL ACCEPT SW.	
PUR-GRY	COMM1	GRY	COMM1	YELLOW	COMM1	BLU-WHTE	COMM1	YEL-ORNG	COMM1
GRY	NC	GRY-WHTE	NC	GRY-ORNG	TRIG	BLU	NC	GRY-WHTE	TRIG
RED-BLU	NC	GRY	COMM2	GRY	NC	BLU	NC	GRY-WHTE	TRIG
BROWN	COMM2	YEL-ORNG	TRIG	YEL-ORNG	COMM1				
WHITE-GRY	TRIG	GRY	NC	BLU	TRIG				

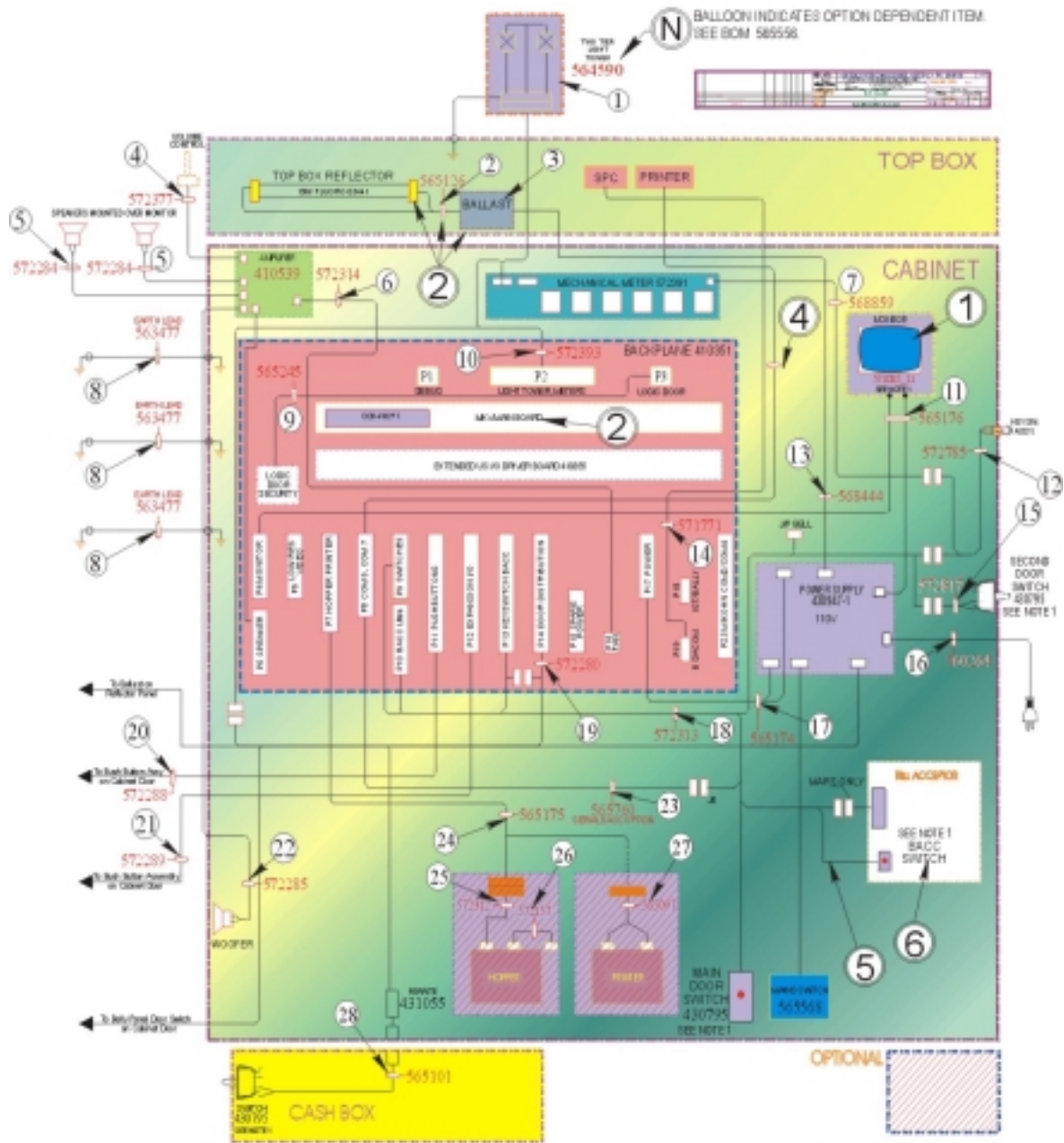

Ref-US500CB_TB02.cdr



SECTION 17
LOOM ASSEMBLY
for
CABINET & TOP BOX

REF No.	DESCRIPTION	QTY	PART No.
1	LIGHT TOWER ASSEMBLY	1	0001-564590
2	LOOM ASSEMBLY – T/B FLUORO	1	3105-565126
3	BALLAST 15W	1	5501-430946
4	LOOM ASSEMBLY – VOLUME CONTROL	1	3120-572377
5	LOOM ASSEMBLY – SPEAKER ASSEMBLY	2	3120-572284
6	LOOM ASSEMBLY – INTERFACE to AMPLIFIER 24V	1	3109-572314
7	LOOM ASSEMBLY – METER SWITCH INPUT	1	3109-568859
8	LOOM ASSEMBLY – BRAID EARTH LEAD	3	3109-563477
9	LOOM ASSEMBLY – LOGIC DOOR - SECURITY	1	3109-565245
10	LOOM ASSEMBLY – EHM to EGM PULSE	1	3109-572393
11	LOOM ASSEMBLY – BACKPLANE to MONITOR	1	3109-565176
12	JACKPOT AUDIT & METERS SWITCH ASSEMBLY	1	3121-572785
13	LOOM ASSEMBLY – POWER SUPPLY to FLUORO PCB	1	3109-568444
14	LOOM ASSEMBLY – VIDEO GAME to SPC BOARD	1	3109-571771
15	LOOM ASSEMBLY – PLUG BREAK to DOOR SWITCH	1	3109-572817
16	LOOM ASSEMBLY – LEAD US_PpIEC_S SJT_2M4_BLK	1	5815-560264
17	LOOM ASSEMBLY – DC POWER	1	3109-565174
18	LOOM ASSEMBLY – MAIN MACHINE	1	3109-572313
19	LOOM ASSEMBLY – INTERFACE to COINCHUTE SECURITY	1	3109-572280
20	LOOM ASSEMBLY – SMALL PUSH BUTTONS	10	3122-572288
21	LOOM ASSEMBLY – SMALL PUSH BUTTONS	4	3122-572289
22	LOOM ASSEMBLY – WOOFER ASSEMBLY	1	3120-572285
23	LOOM ASSEMBLY – SERIAL COMMS for BNA1	1	3109-565760
24	LOOM ASSEMBLY – BACKPLANE to HOPPER/PRINTER	1	3109-565175
25	LOOM ASSEMBLY – HOPPER PLUG to HOPPER PCB	1	3106-564350
26	LOOM ASSEMBLY – PHOTO OPTIC to HOPPER	1	3119-564389
27	LOOM ASSEMBLY – HOPPER PLUG to PRINTER	1	3109-565097
28	LOOM ASSEMBLY – CASHBOX SWITCH (In Stand)	1	3109-565101



SECTION 18

**SECURING MACHINES
TO
BASE ASSEMBLY**



SECTION 18

INTRODUCTION

This document defines the requirements and procedures to ensure compliance with the standards AS3260 and IEC 950. These standards define the stability requirements for equipment in normal operation and service mode.

Failure to comply with these standards may result in installations being, or becoming, unstable, occasioning injury and damage to persons and property. Aristocrat will not be responsible for any outcome associated with stability should the instructions in this document not be applied.

Care should be exercised during shipment and transit to prevent machines from toppling. Do not apply any undue offset forces and secure all loads prior to transport.

Ensure all machines and/or base assemblies being moved are secured to form a single assembly. Do not transport machines, or components thereof, unless they are duly connected together.

Base assemblies, or “furniture,” must be constructed appropriately to support the static load of the machine, as well as loads applied from forces imposed, in keeping with the above standards.



SECTION 18

SECURING MACHINE TO BASE ASSEMBLY

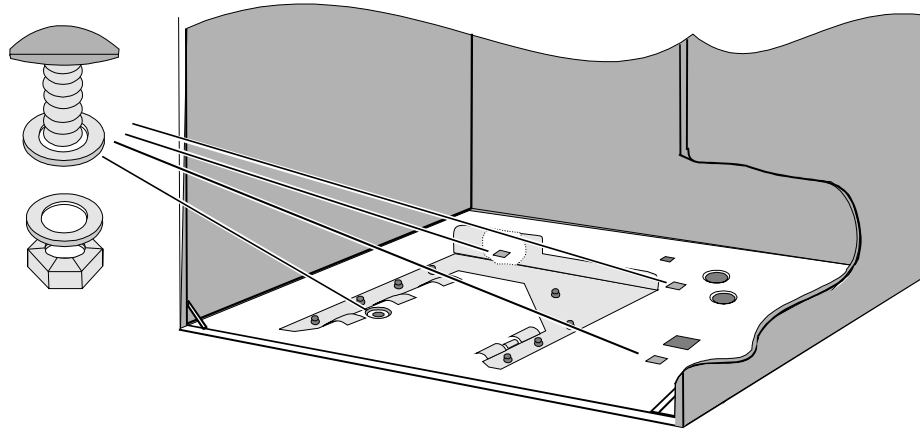

1. Secure Aristocrat machine to base assembly with 4 x 8mm (5/16" BSW) bolts, washers and hex nuts, as supplied.
2. Zinc plated steel bolts to penetrate machine base and top surface of the base assembly.
3. Coach bolts may be used with timber or manufactured wood base assemblies - bolts are to be inserted from the bottom up and washers and nuts are to be inside the machine unit.
4. For metal base assemblies, bolts to be inserted from the top down with a washer on both sides.
5. Ensure that at least two threads protrude from the nut when tight.
6. Bolting of machine to base assembly is not to occur until base assembly has been secured, but must be considered before any other work is commenced.

SCV080AB



1(a) - SIDE-TO-SIDE LAYOUT (3 OR MORE MACHINES)

Bolting base assemblies together

1. Secure with 2 bolts, washers and hex nuts.
2. Ensure zinc plated steel bolts penetrate both sides of base unit.
3. Coach bolts may be used with timber or manufactured wood base assemblies - washer to be on nut side only. Metal base assemblies to have washers on both sides.
4. Ensure that at least two threads protrude from the nut when tight.

Use 8mm (5/16" BSW) bolts, washers and hex nuts.

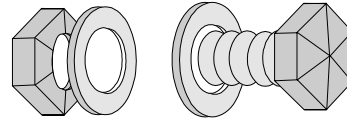

Secure with 2 bolts, washers, hex nuts.

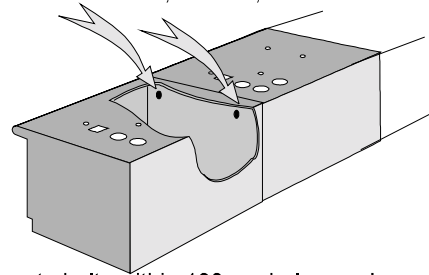

Locate bolts within 100mm below and inward of upper rear and front interior corners.

1(b) - SIDE-TO-SIDE LAYOUT (1-3 MACHINES)

Bolt base assemblies together (2-3 machines), AND strap base assemblies to floor (1-3 machines), AND secure base assemblies to floor at front with right-angled brackets (stand-alone machines).

1. For 2 or 3 machines, bolt base assemblies together as described above.
2. For 2 or 3 machines side to side, secure each to the floor with 1 floor strap, one 4mm countersunk self tapping screw, and 1 bolt, washers and nuts as appropriate for the flooring material (eg. Dynabolts 6mm for concrete floors). **For stand-alone machines / base-assemblies, use two straps and 2 right-angled brackets.**
3. Left hand strap to be secured between machine base and base assembly using the rear left hand bolt. A 4mm self tapping screw can be used to hold it in position. Care should be taken to drive the screw all the way down to reduce the profile under the machine. Use rear right hand bolt for right strap on stand-alone machines.
4. Strap to project over rear of base assembly. With the machine and base assembly secured, the strap is to be bent towards the floor. At the floor, the strap to be bent away from base assembly, and secured to the floor in the strap holes closest to the bend. Strap may be trimmed 20mm beyond the bolt.

1 machine - secure with left and right hand floor straps between the base assembly and the Aristocrat machine. Also, secure with 2 right-angled brackets in front.

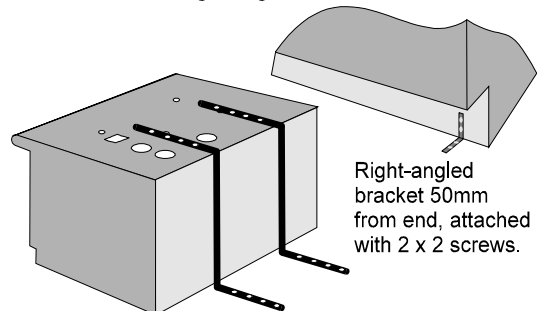

Right-angled bracket 50mm from end, attached with 2 x 2 screws.

2 or 3 machines - secure each with left hand strap (door hinge side).

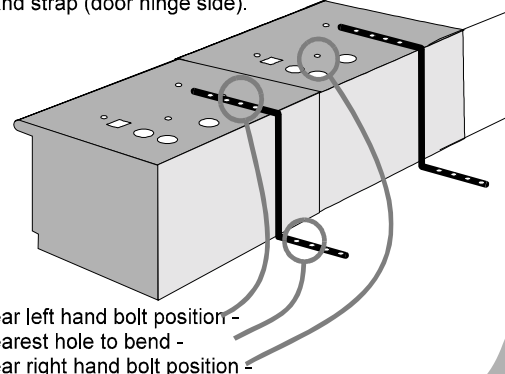

Rear left hand bolt position -
Nearest hole to bend -
Rear right hand bolt position -

Part Numbers: Stand-to-Floor Strap: No. 0954 564957
Right-angled Bracket: No. 0954 564958

SCV082AB



SECTION 18

2 - BACK-TO-BACK LAYOUT

Bolting base assemblies together

1. For 8 or more machines, secure with 1 bolt, washers and nut. For 2, 4 or 6 machines, secure with 2 bolts, washers and hex nuts.

2. Bolts, washers, nuts and attaching guidelines are same as for side-to-side layouts.

Use 8mm (5/16" BSW) bolts, washers and hex nuts.

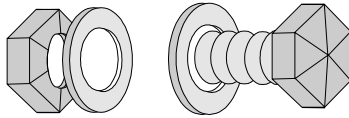

8 or more machines - secure each pair with 1 bolt, washers and hex nut. Locate bolts within +/- 25mm of the vertical centreline and 100mm below the ceiling of the base assembly.

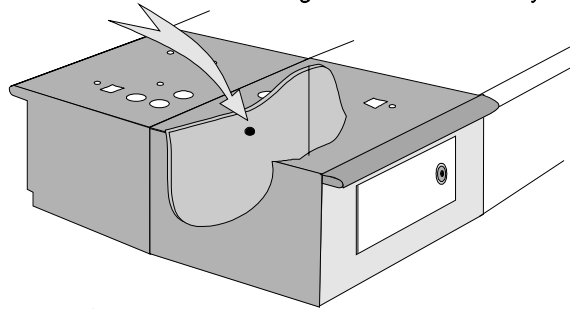

2, 4, or 6 machines - secure each pair with 2 bolts, washers and nuts.

Locate bolts within 100mm below and inward of upper rear interior corners.

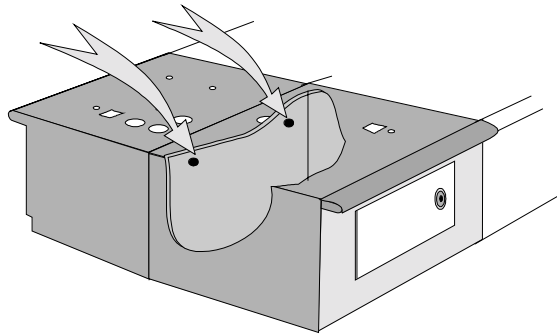

SCV082BB