



**TECHNICAL MANUAL
GLASSWASHER**

**GW-40 BarMaster
GW-40-D BarMaster**

Installation, Operation and Maintenance Instructions

Insinger Machine Company
6245 State Road
Philadelphia, PA 19135-2996

800-344-4802
Fax 215-624-6966



Thank you for purchasing this quality Insinger product.

On the space provided below please record the model, serial number and start-up date of this unit:

Model: _____

Serial Number: _____

Start-Up Date: _____

When referring to this equipment please have this information available.

Each piece of equipment at Insinger is carefully tested before shipment for proper operation. If the need for service should arise please contact your local Authorized Insinger Service Company.

A Service Network Listing is provided on our web site, www.insingermachine.com or call Insinger at 800-344-4802 for your local authorized servicer.

For proper activation of the Insinger Limited Warranty a SureFire™ Start-Up & Check-Out Service should be completed on your machine. Refer to the Introduction section in this manual for an explanation of Insinger SureFire™ Start-Up & Check-Out Program.

Please read the Insinger Limited Warranty and all installation and operation instructions carefully before attempting to install or operate your new Insinger product.

To register your machine for warranty by phone, fax or the internet or for answers to question concerning installation, operation, or service contact our Technical Services Department:

TECHNICAL SERVICE CONTACTS	
Toll-Free	800-344-4802
Fax	215-624-6966
e-mail	service@insingermachine.com
Web site	www.insingermachine.com

TABLE OF CONTENTS	
Part 1 Technical Information Catalog Cut-sheet Introduction Warranty	1-9
Part 2 Installation & Connection Instructions	10-11
Part 3 Operating Instructions	12-13
Part 4 Cleaning/General Maintenance	14
Part 5 Maintenance and Repair Procedures	15-16
Part 6 Electrical Schematics & Replacement Parts	17-35



GW-40 BarMaster

AUTOMATIC GLASSWASHER

DESIGN

Automatic, chemical sanitizing glasswasher with timed wash and rinse cycles. Fully automatic operation with power on/off button. Capacity is 40- 20"x20" racks per hour. Designed to save energy and water. Quiet operation.

STANDARD EQUIPMENT

- 40 racks per hour
- 1.4 gallon per cycle
- 11" wash clearance
- Electromechanical controls
- Automatic fill, wash, drain, and rinse cycles
- S/S frame, legs and feet
- Door safety switch
- Adjustable bullet feet
- EZ-Clean™ wash and rinse arms
- Multiple cycle selection 90 seconds, 150 seconds
- 115V electrical connection
- Side panels

OTHER SPECIFICATIONS

- Sanitizer required:
 - Sodium Hypochlorite 50 ppm
 - Iodophor 12.5 ppm
- Operating temperatures:
 - 120°F minimum (140°F recommended)

OPTIONAL EQUIPMENT

- Heated maintenance tank to maintain 120°F-140°F water



6245 State Road
Philadelphia, PA 19135-2995
215-824-4800
215-824-8968 FAX
800-344-4802
www.insingermachine.com





GW-40 BarMaster

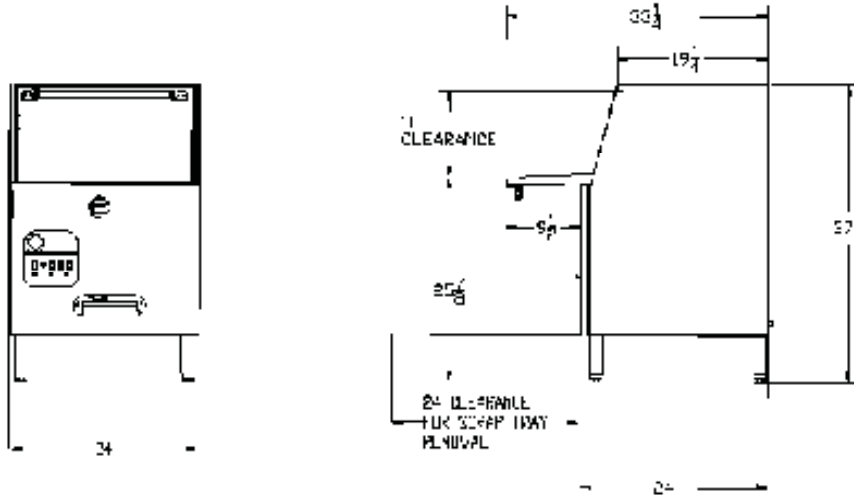

Note: For all rough in connections see Installation and Layout Detail drawing

SPECIFICATIONS

CONSTRUCTION- Hood and tank constructed of type 304 S/S. Hood unit of all welded seamless construction. S/S frame, legs and feet. All internal castings are non-corrosive lead free nickel alloy or bronze.

CONTROLS- Electro-mechanical controls are simple to use and located in a splash proof box.

WASH/RINSE SYSTEM- Rotating lower S/S wash arms. End caps are easily removable for cleaning.

DRAIN SYSTEM- Drain valve externally controlled.

Capacity Per Hour	Tank Capacity	Pump Motor Size	Optional Maintenance Tank	Water Inlet Temperature	Water Usage	Water Requirements
40 racks	1.5 gals	1 hp	1.8 kW	120°F minimum 140°F recommended	1.4 gal./rack 50 gals./hr.	6 gpm max. flow 20-25 psi flow supply
Exhaust Hood Requirement	Time Cycle	Peak Rate Drain Flow	Shipping Weight	Current Draw	Washer with Optional Maintenance Tank	
none	Standard-90 sec. Extreme-150 sec.	9 gals./min.	210 lbs.	115w/1PH/Hz.....	14.0.....16.0	

2/2008 PRINTED IN USA
Information and specifications subject to change without notice.

Available in AutoQuotes and KOL Catalog



GW-40-D BarMaster

AUTOMATIC DOUBLE DOOR GLASSWASHER

DESIGN

Automatic, chemical sanitizing glasswasher with timed wash and rinse cycles. Fully automatic operation with power on/off button. Pass through doors make it accessible from the waitstaff side and the bartender side and can be operated from each side. Capacity is 40- 20"x20" racks per hour. Designed to save energy and water. Quiet operation.

STANDARD EQUIPMENT

- 40 racks per hour
- 1.4 gallon per cycle
- 11" wash clearance
- Electromechanical controls
- Start button and cycle indicator light on front and back side
- Automatic fill, wash, drain, and rinse cycles
- S/S frame, legs and feet
- Squared off front and rear door panels
- Physical stop in unit assures correct placement of rack
- Door safety switch
- Adjustable bullet feet
- EZ-Clean™ wash and rinse arms
- Multiple cycle selection 90 seconds, 150 seconds
- 115V electrical connection
- Side panels

OTHER SPECIFICATIONS

- Sanitizer required:
 - Sodium Hypochlorite 50 ppm
 - Iodophor 12.5 ppm
- Operating temperatures:
 - 120°F minimum (140°F recommended)

OPTIONAL EQUIPMENT

- Heated maintenance tank to maintain 120°F-140°F water



6245 State Road
Philadelphia, PA 19135-2995
215-824-4800
215-824-8968 FAX
800-344-4802
www.insingermachine.com





GW-40-D BarMaster

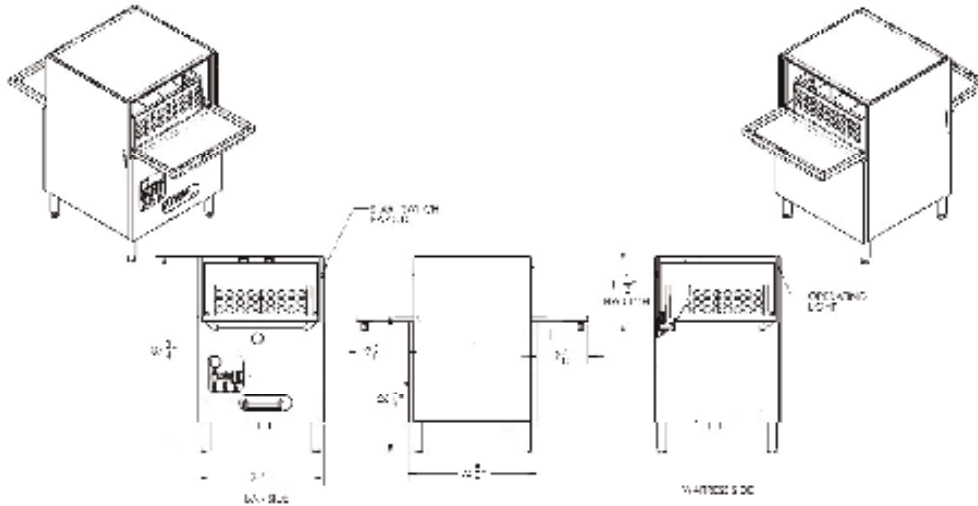

Note: For all rough in connections see Installation and Layout Detail drawing

SPECIFICATIONS

CONSTRUCTION- Hood and tank constructed of type 304 S/S. Hood unit of all welded seamless construction. S/S frame, legs and feet. All internal castings are non-corrosive lead free nickel alloy or bronze.

CONTROLS- Electro-mechanical controls are simple to use and located in a splash proof box.

WASH/RINSE SYSTEM- Rotating lower S/S wash arms. End caps are easily removable for cleaning.

DRAIN SYSTEM- Drain valve externally controlled.

Capacity Per Hour	Tank Capacity	Pump Motor Size	Optional Maintenance Tank	Water Inlet Temperature	Water Usage	Water Requirements
40 racks	1.5 gals	1 hp	1.8 kW	120°F minimum 140°F recommended	1.4 gal./rack 56 gals./hr.	6 gpm max. flow 20-25 psi flow supply
Exhaust Hood Requirement	Time Cycle	Peak Rate Drain Flow	Shipping Weight	Current Draw	Washer with Optional Maintenance Tank	
none	Standard-90 sec. Extreme-150 sec.	9 gals./min.	210 lbs.	115w/1PH/1HZ.....	14.0.....16.0	

2/2008 PRINTED IN USA
Information and specifications subject to change without notice.

Available in AutoQuotes and KCL Catalog

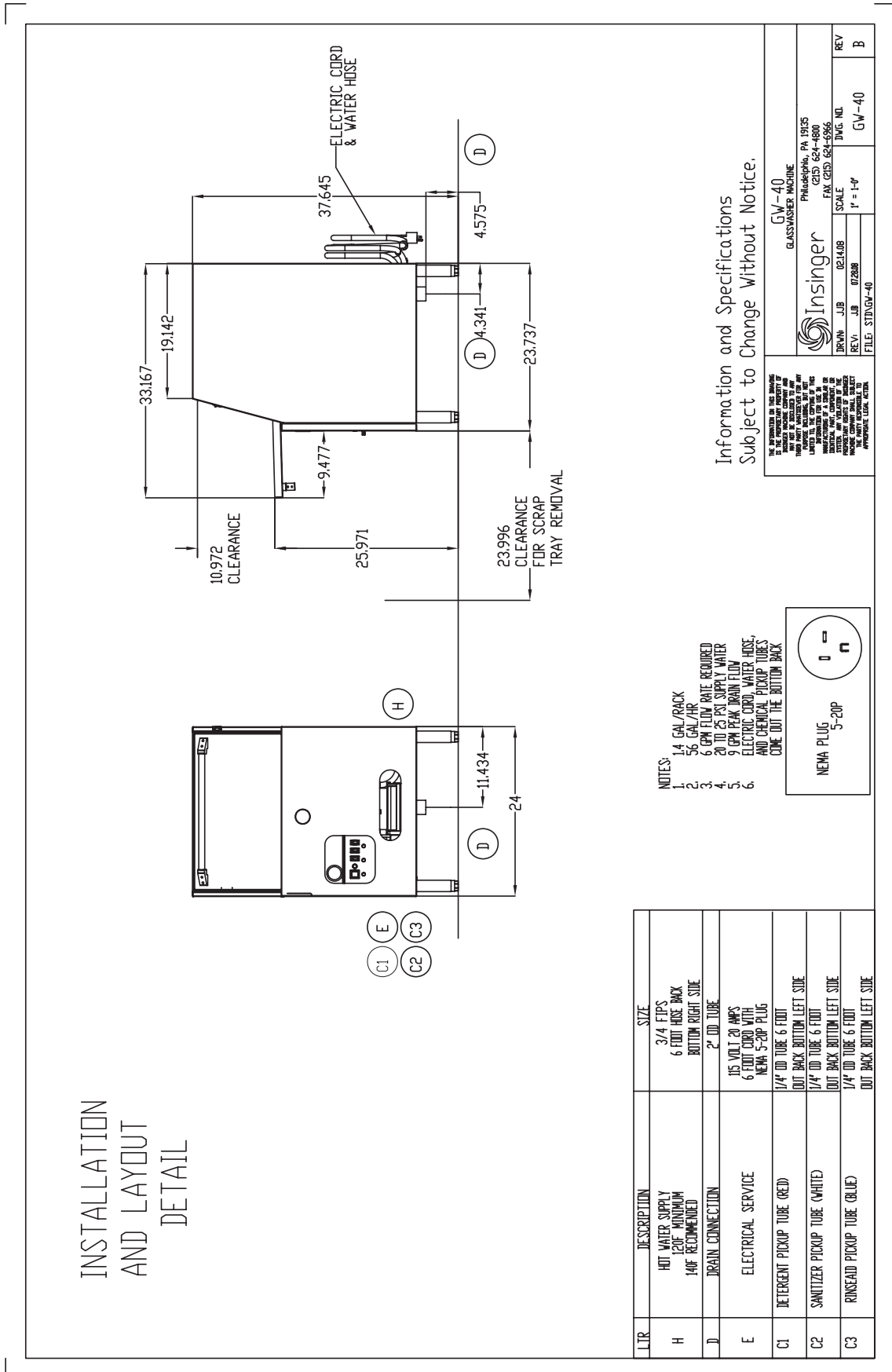

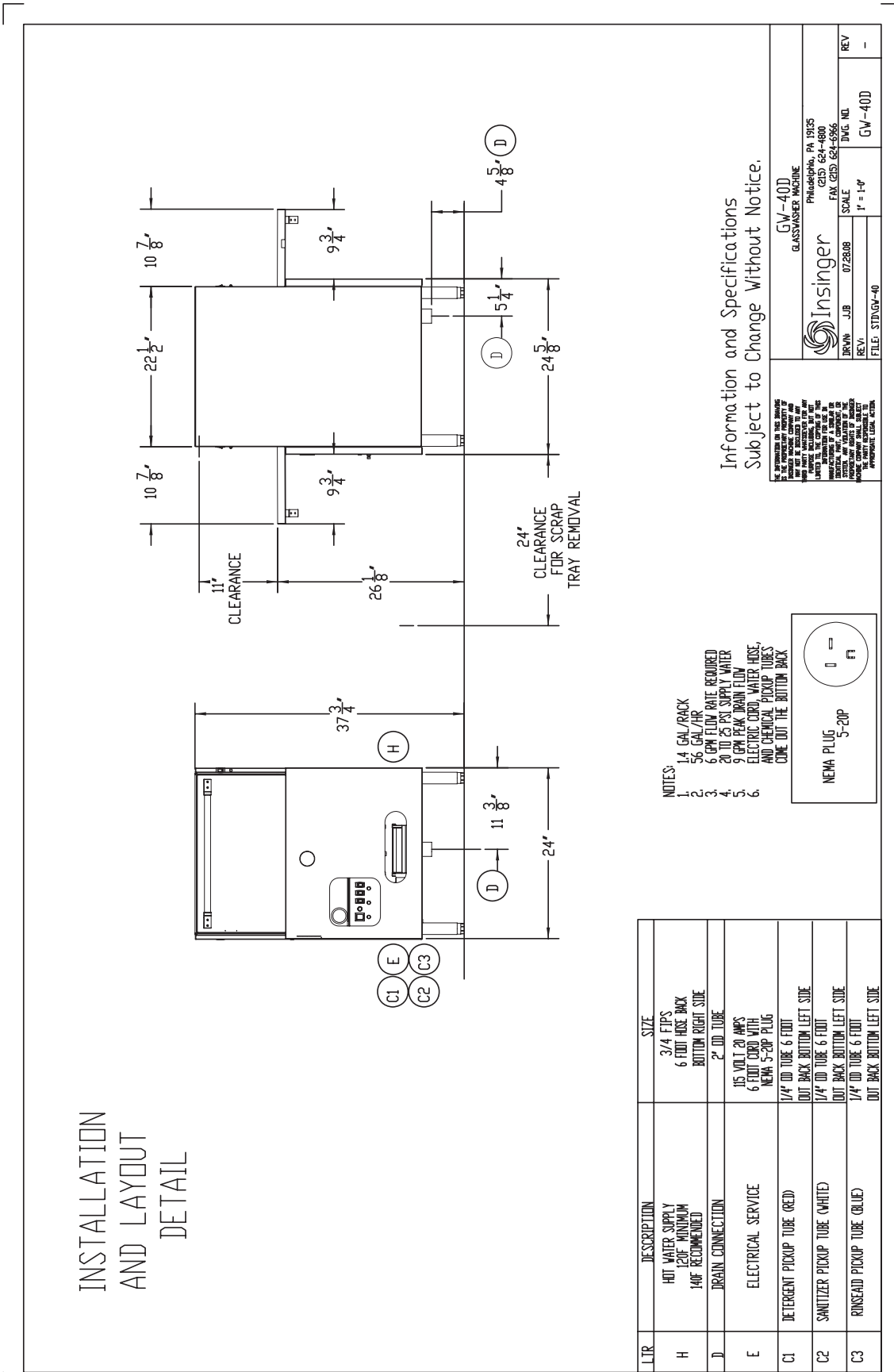

LTR	DESCRIPTION	SIZE
H	HOT WATER SUPPLY 120" MINIMUM 140" RECOMMENDED	3/4" FIPS 6 FOOT HOSE BACK BOTTOM RIGHT SIDE
D	DRAIN CONNECTION	2" OD TUBE
E	ELECTRICAL SERVICE	115 VOLT 20 AMPS 6 FOOT CORD WITH NEMA 5-20P PLUG
C1	DETERGENT PICKUP TUBE (RED)	1/4" OD TUBE 6 FOOT OUT BACK BOTTOM LEFT SIDE
C2	SANITIZER PICKUP TUBE (WHITE)	1/4" OD TUBE 6 FOOT OUT BACK BOTTOM LEFT SIDE
C3	RINSE AID PICKUP TUBE (BLUE)	1/4" OD TUBE 6 FOOT OUT BACK BOTTOM LEFT SIDE

GW-40 BARMASTER GLASSWASHER

INTRODUCTION

Purpose

The purpose of this technical manual is to provide installation, operation, cleaning and maintenance directions.

A section is provided for replacement parts.

Scope

This manual contains all pertinent information to assist in the proper installation, operation, cleaning, maintenance, and parts ordering for the Insinger GW-40 and GW-40-D Glasswashers.

The installation instructions are intended for qualified equipment installers. The operation and cleaning instructions are intended for the daily users of the equipment. The maintenance and parts sections are intended for qualified service and/or maintenance technicians. Replacement parts may be ordered directly from our factory or from your local Insinger Authorized Service Agency. You can speak to the Insinger Technical Services Department, 800/344-4802, or e-mail us at service@insingermachine.com. When calling for warranty information or replacement parts please provide the model and serial number of your Insinger Equipment. These important numbers should be noted in this manual on the spaces provided on the opening page.

Surefire™ Start-up & Check-out Program

Insinger is proud to offer our exclusive Surefire™ Start-up & Check-out Program to our commercial customers. This service is included in the purchase price of your new Insinger dishwasher. We will provide an authorized factory service technician for the initial start-up of your new Insinger dishwasher to ensure it is running at optimum levels from the very first pass. Please call the factory or your local Insinger Sales Representative to schedule this service.

NSF 3-2008 requirements for detergent and chemical sanitizer dispensers.

This machine must be operated with detergent in the integral detergent dispensing system to insure proper washing.

This machine must be operated with sanitizer in the integral sanitize dispensing system to insure proper sanitizing.

Intended use

The Insinger GW-40 or GW-40-D may only be used for cleaning glasses, cups and similar restaurant ware and commercial catering.

Any change in design or use of the glasswasher carried out without the written permission of Insinger, will lead to warranty nullification.

If damage is caused to the glasswasher due to failure to observe the instructions given in this manual, no claims under the warranty agreement can be submitted to Insinger Machine Company.

Safety Instructions

Make sure that you have read and understood the operating instructions before you start to use the glasswasher. The Insinger customer service department can tell you how to operate the washer and how it works.

Definitions

Throughout this guide you will find the following terms: WARNING, CAUTION, & NOTE.

WARNING indicates potential physical danger.

CAUTION indicates potential equipment damage.

NOTE indicates helpful operating hints or tips.

You will visually be able to identify each as shown below:



NOTE:

Indicates helpful operating hints or tips.



WARNING:

Indicates potential physical danger.

CAUTION:

Indicates potential equipment damage.

INSINGER MACHINE COMPANY LIMITED WARRANTY

Insinger Machine Company, Inc. (Insinger) hereby warrants to the original retail purchaser of this Insinger Machine Company, Inc. product, that if it is assembled and operated in accordance with the printed instructions accompanying it, then for a period of either 15 months from the date of shipment from Insinger or 1 year (12 months) from the date of installation or start-up that said Insinger product shall be free from defects in material and workmanship. Whichever one of the two aforesaid limited warranty time periods is the shortest shall be the applicable limited warranty coverage time period.

Insinger may require reasonable proof of your date of purchase; therefore, you should retain your copy of invoice or shipping document.

This limited warranty shall be limited to the repair or replacement of parts which prove defective under normal use and service and which on examination shall indicate, to Insinger's satisfaction, they are defective. Any part that is claimed to be defective and covered by this limited warranty must be returned to Insinger. An RMA# must be obtained from the Insinger Warranty Department before returning any material. Return may be done through an Authorized Service Agency. Furnish serial number of machine and RMA# with shipment and send to:

Insinger Machine Company
6245 State Road
Philadelphia, PA 19135-2996

If Insinger's inspection confirms the defect and the claim, Insinger will repair or replace such part without charge and return it to you freight or postage prepaid.

This limited warranty does not cover any failure or accident, abuse, misuse, alteration, misapplication, improper installation, fire, flood, acts of God or improper maintenance or service,

or failure to perform normal and routine maintenance as set out in the instruction booklet (operating instructions) or for improper operation or failure to follow normal operating instructions (as set out in the instruction booklet). Insinger is not responsible nor liable for any conditions of erosion or corrosion caused by corrosive detergents, acids, lye or other chemicals used in the washing and or cleaning process.

Service must be done by either Insinger Appointed Service Agencies or agencies receiving prior authorization from Insinger.

All warranty work must be done during normal working hours, unless purchaser receives prior authorization from Insinger.

There are no other express warrants except as set forth herein and any applicable implied warranties of merchantability and fitness are limited in duration to the period of coverage of this express written limited warranty. This limited warranty supersedes all other express warranties, implied warranties of merchant-ability and fitness or limited warranties as of this date, January 1, 1998. Some states do not allow limitation on how long an implied warranty lasts so this limitation may not apply to you.

Insinger is not liable for any special, indirect or consequential damages. Some states do not allow the exclusion or limitation of incidental or consequential damages, so this limitation nor exclusion may not apply to you.

Insinger does not authorize any person or company to assume for it any other obligation or liability in connection with the sale, installation, use, removal, return or replacement of its equipment: and no such representations are binding on Insinger.

INSINGER MACHINE COMPANY LIMITED WARRANTY- COMMERCIAL MARINE USE

Insinger Machine Company, Inc. (Insinger) hereby warrants to the original retail purchaser of this Insinger Machine Company, Inc. product, that if it is assembled and operated in accordance with the printed instructions accompanying it (installation manual), then for a period of 15 months from the date of installation on board the vessel, that said Insinger product shall be free from defects in material and workmanship.

Insinger may require reasonable proof of your date of equipment install, therefore, you should retain your copy of invoice or shipping document.

This limited warranty shall be limited to the replacement of parts which prove defective under normal use and service and which on examination shall indicate, to Insinger's satisfaction, they are defective. Any part that is claimed to be defective and covered by this limited warranty must be returned to Insinger. Furnish serial number of machine with shipment and send to:

Insinger Machine Company, Inc.
6245 State Road
Philadelphia, PA 19135-2996

If Insinger's inspection confirms the defect and the claim, Insinger will repair or replace such part without charge and return it to you freight or postage prepaid. If part damages are not covered, Insinger will contact the customer and advise.

If a factory trained authorized technician is required to repair or replace defective parts or material during the 18 month warranty period, the cruise line will be responsible for the payment of travel expense and a minimum of four hours labor.

Labor will be billed to the customer at a reduced rate of \$40.00 per hour. If sailing with a vessel is required, then an eight hour per day minimum will apply.

This limited warranty does not cover accident, abuse, misuse, alteration, misapplication, improper installation, fire, flood, or improper maintenance or service, or failure to perform normal and routine maintenance as set out in the instruction booklet (operating instructions) or for improper operation or failure to follow normal operating instructions (as set out in the instruction booklet).

Insinger is not responsible nor liable for any conditions of erosion or corrosion caused by corrosive detergents, acids, lye or other chemicals used in the washing, caring and or cleaning process.

Warranty service must be done by either Insinger Appointed Service Agencies or agencies, customers galley engineers receiving prior authorization from Insinger.

There are no other express warrants except as set forth herein and any applicable implied warranties of merchantability and fitness are limited in duration to the period of coverage of this express written limited warranty. This limited warranty supersedes all other express warranties, implied warranties of merchantability and fitness or limited warranties as the above date.

Insinger does not authorize any person or company locally or overseas to assume for it any other obligation or liability in connection with the sale, installation, use, removal, return or replacement of its equipment; and no such representations are binding on Insinger.

INSTALLATION AND CONNECTION

Check for Completeness:

After unpacking the machine, first check the delivery against the packing slip to ensure that it is complete, and inspect for damage that may have occurred during transportation. Immediately report any damage to the carrier, the insurance company and the manufacturer.

Setting Up and Alignment:

When setting up the machine, remember that the machine gives off steam during operation (when you open the door). Protect adjacent wooden furniture to prevent it absorbing moisture and swelling.

CAUTION:

Protect the washer against frost. Systems that carry water can be damaged if they freeze.

The machine must be completely level when installed. Adjust the machine's feet to compensate for any unevenness of the floor.

CAUTION:

Note all the information on the enclosed connection diagram. For the machine to work correctly, the required water pressure and flow rate must be guaranteed at all times.

Connection to the Water Supply:

All plumbing connections must comply with all applicable local, state, and national plumbing codes. Flush the incoming water supply to remove all foreign debris prior to connecting to the unit.

Connect the hot water (120°F minimum) supply hose (1/2" IPS) from the fill solenoid valve located behind the front panel on the right side to the building water supply. Recommended installation includes the use of a ball valve (supplied by others). A pressure regulator (supplied by others) is required if the water pressure fluctuates or is greater than the recommended pressure (22psig). The unit has a built in air gap. A vacuum breaker is not required.

Connection to the Drain:

The unit is equipped with a 2" OD drain connection and must be connected to drain capable of handling a 9.0 gal/min flow. A proper air gap must be supplied between the unit and the building drain connections. Failure to provide air gap will result in improper or inconsistent draining of unit and potential overflow condition.

Connection to the Power Supply:

Electrical and grounding connections must comply with all applicable portions of the National Electric Code (ANSI/NFPA 70) and/or other electrical codes that may apply.

The unit is 115 volts and the total amp load is 14 fla for the washer without the optional maintenance heater and 16.0 fla for the washer with the optional maintenance heater. The unit is internally wired so that the wash pump and the optional maintenance heater do not operate at the same time.



WARNING: Electrical Shock Hazard

Plug into a grounded 3 prong outlet.

Do not remove ground prong.

Do not use an adapter.

Do not use an extension cord.

Failure to follow these instructions can result in death, fire, or electrical shock.

INSTALLATION AND CONNECTION

A 120 volt, 60 Hz, AC only, 20 amp, fused electrical supply is required. A time-delay fuse or circuit breaker is recommended. It is recommended that a separate circuit serving only this appliance be provided.

This washer is equipped with a power supply cord having a grounded 3 prong plug.

To minimize possible shock hazard, the cord must be plugged into a mating, grounded 3 prong outlet, grounded in accordance with local codes and ordinances. If a mating outlet is not available, it is the personal responsibility and obligation of the customer to have the properly grounded outlet installed by a qualified electrician.

If codes permit and a separate ground wire is used, it is recommended that a qualified electrician determine that the ground path is adequate.

Do not ground to gas pipe.

Check with a qualified electrician if you are not sure the washer is properly grounded.

Do not have a fuse in the neutral or ground circuit.

Grounding Instructions:

For a grounded, cord-connected washer:

This washer unit must be grounded. In the event of a malfunction or breakdown, grounding will reduce the risk of electrical shock by providing a path of least resistance for electric current. This washer is equipped with a cord having an equipment-grounding conductor and a grounding plug. The plug must be plugged into an appropriate outlet that is properly installed and grounded in accordance with all local codes and ordinances.



WARNING: **Electrical Shock Hazard**

Improper connection of the equipment-grounding conductor can result in a risk of electrical shock. Check with a qualified electrician or serviceman if you are in doubt as to whether the appliance is properly grounded. Do not modify the plug provided with the appliance— if it will not fit the outlet, have a proper outlet installed by a qualified electrician.

Before using the washer, check that all electrical protection systems are working correctly.

Attention: The machine should not be regarded as isolated from the power supply unless switched off at the customer's main switch or unplugged.

Chemical Connection:

Use a qualified detergent/chemical supplier for your detergent, rinse aid, and sanitizer needs.

The machine is supplied with a chemical dispensing system that is internally wired and ready for use. Position the chemical bottles close to the Glasswasher making sure that they will not be prone to being knocked over or interfere with normal activity around the Glasswasher. Insert the color coded pickup tubes into the correct containers.

The RED tube is for a nonchlorinated, non foaming, commercial detergent recommended for your Glasswasher by your local detergent/chemical supplier.

The CLEAR/WHITE tube is for a chemical sanitizer using a sodium hypochlorite solution or an iodine based sanitizing solution, as recommended by your local detergent/chemical supplier.

The BLUE tube is for a low temperature rinse aid recommended by your local detergent/chemical supplier for the Glasswasher.

A priming push button switch for each of the chemicals is located on the front of the control box. Press and hold the priming switches until the chemical is seen being dispensed into the wash sump.

A speed potentiometer is located on the underneath side of the control box for adjusting the delivery of the chemicals. This adjustment should be left for a qualified person to perform.

Final Tasks:

The washer must be connected to all services (electricity supply and to the fresh water and waste water systems), prior to testing the machine & installation.

OPERATING INSTRUCTIONS

START-UP AND CHECK

Before proceeding with the start up verify the following:

- Open the door(s) and verify that all packaging materials and tie downs have been removed.
- Verify that the scrap and pump screens are properly located.
- Verify that the drain stopper is closed and that the linkage is free.
- Check that the plugs are securely screwed into the ends of the wash arms.
- Check that the wash arm is securely screwed into the base and that the arm rotates freely.
- Check that the external scrap screen is installed.
- Check the levels of all chemical containers. Replace if necessary.
- Verify that the incoming voltage is correct.

INSTALLATION START-UP PROCEDURE

- Turn the glasswasher ON/OFF switch to the OFF position.
- Turn the Glasswasher DE-LIME switch to the OFF position.
- Turn the Glasswasher cycle time switch to the STD position.
- Turn the water supply to the unit ON and check for leaks.
- Turn the electric power supply to the glasswasher ON
- Turn the Glasswasher ON/OFF switch to the ON position.
 - After a slight delay the water solenoid valve opens and the glasswasher fills.
 - The cycle light will be on while the fill solenoid is energized.
 - Confirm water supply pressure. (22-24 psi)
 - After the fill solenoid valve shuts off check the water level.
 - The water level should be at the lowest edge were the back and bottom of the sump meet. Adjust water level by adjusting incoming water supply to 22-24 psi.

- Press the PRIME switch for the detergent and hold it until there is detergent dropping into the fill box of the Glasswasher sump.
- Repeat for the Sanitizer and rinse-aid systems.
- With the door(s) closed press the cycle start switch (located near door handle on right side panel of Glasswasher) (Double door units have cycle start switches on both sides).
- The following occurs:
 - Cycle light comes ON
 - Pump starts for the wash cycle
 - Detergent dispenses into fill box.
 - After wash time is finished
 - Drain opens and water drains into the external scrap screen and goes to the building drain.
 - Drain closes
 - Sump fills with water through the fill box.
 - Sanitizer dispenses into fill box
 - Rinse-Aid dispenses into fill box.
 - After fill cycle is finished
 - Pump starts for the rinse cycle
 - After rinse cycle is finished
 - Cycle light goes OFF
 - Optional clean light (green) comes on and stays on until a door is opened

**NOTE:**

Pump stops when door is opened but the cycle continues

OPERATING INSTRUCTIONS

**NOTE:**

Pump stops when the door is opened but cycle does not stop.

DE-LIME

- Open the door and remove any glassware rack that may have been left in the washer.
- Manually add to the water in the sump the recommended delime agent recommended by your local detergent/chemical supplier.
- Close the door(s)
- Press the de-lime switch to the ON position.
- The pump will start and continue to operate until the delime switch is pressed to the OFF position.
- The cycle light will be lit while the delime switch is in the ON position.
- After the delime cycle has been performed operate at least one wash cycle without any glassware in the unit.
- Note pump stops when door is opened but cycle does not stop.

MANUAL FILL/DRAIN

- The front of the control panel contains a manual fill and drain switch.
- Pressing this switch to the top position the unit will fill with water.
- Pressing this switch to the bottom position the unit will drain.
- Do not operate a WASH or DELIME cycle after pressing the drain switch.

STD/EXT WASH

- This switch determines the length of the wash cycle.
- STD position uses the standard 90 second cycle.
- EXT position uses the extended 150 second cycle.

ADDING RINSE AID, SANITIZER, & DETERGENT

The machine is supplied with a chemical dispensing system that is internally wired and ready for use. Position the chemical bottles close to the Glasswasher making sure that they will not be prone to being knocked over or interfere with normal activity around the Glasswasher. Insert the color coded pickup tubes into the correct containers.

The RED tube is for a non chlorinated, non foaming, commercial detergent recommended for your Glasswasher by your local detergent/chemical supplier.

The CLEAR/WHITE tube is for a chemical sanitizer using a sodium hypochlorite solution or a iodine based sanitizing solution, as recommended by your local detergent/chemical supplier.

The BLUE tube is for a low temperature rinse aid recommended by your local detergent/chemical supplier.

A priming push button switch for each of the chemicals is located on the front of the control box. Press and hold the priming switches until the chemical is seen being dispensed into the wash sump.

A speed potentiometer is located on the underneath side of the control box for adjusting the delivery of the chemicals. This adjustment should be left for a qualified person to perform.

CAUTION:

Only use detergent and rinse aid which are suitable for commercial washers, a non-foaming industrial alkaline detergent.

Do not use any soap intended for a residential dishwasher. This leads to large amounts of foam building up in the washer and will void your manufacturers warranty.

CAUTION:

Detergents for commercial dishwashers cause corrosion. Always follow the instructions on the packaging and drums.

CAUTION:

Do not mix different detergent products, this could cause the dosing pump to break down due to crystallization.

CLEANING/GENERAL MAINTENANCE

Daily Cleaning:

- At the end of each day, or 8 hours
- Drain the machine by depressing the manual drain switch.
- After the unit has drained, turn the power switch to the off position.
- Open the door and remove the lower spray arm by unscrewing the knurled fastener.
- Inspect the spray nozzles to make sure that they are free of any debris that could affect their spray patterns.
- Remove the end caps from the spray manifold and clean with the brush provided. Do not strike the manifold against solid objects. Flush the manifold with water.
- Remove and clean the scrap and pump intake screens carefully to avoid any waste particles from falling into the tank. Empty any waste particles into an approved waste receptacle. Back flush the scrap screens until clean. Do not strike the scrap tray against solid objects.
- Clean the inside of the wash tank with clean water.
- Remove the scrap tray carefully from the drain sump to avoid any waste particles from falling into the drain sump. Empty any waste particles into an approved waste receptacle. Back flush the scrap tray until it is clean. Do not strike the scrap tray against solid objects.
- Thoroughly clean the interior of the drain sump.
- Check the levels of the chemical containers and replace as needed. When replacing chemical containers it may be necessary to prime the pumps by using the prime buttons.
- Replace the external scrap tray.
- Replace the pump intake screen.
- Replace the scrap screens.
- Replace the manifold end caps.
- Replace the manifold and screw in the knurled fastener. Confirm that the manifold is free rotating.
- Leave the door(s) open overnight to allow drying.

**NOTE:**

Clean the scrap tray after every use period or more frequently during heavy usage times.

Do not allow the scrap tray to become clogged with soil or waste particles.

De-liming:

Machines that are operated in hard water areas and are not connected to an external water treatment system must be de-limed from time to time. There are de-liming agents specially designed for commercial dishwasher available for this purpose. Please consult your detergent supplier.

CAUTION:

De-liming agents for commercial dishwashers cause corrosion.
Always follow the instructions for use and safety instructions on the packaging and drums.

De-liming solutions or other acids must not come in contact with household bleach (sodium hypochlorite) or any chemicals containing chlorine, iodine, bromine, or fluorine. Mixing will cause hazardous gases to form. Skin contact with de-liming solutions can cause severe irritation and possible chemical burns. Consult your chemical supplier for specific safety precautions.

TROUBLESHOOTING

Faults where it is *not necessary* to call Insinger.

You can rectify minor faults yourself following the steps described in the table below. If you are unable to rectify the fault, contact Insinger service (1-800-344-4802.)

Do not open any panels or expose any parts of the machine if tools are necessary to do so. Risk of electric shock.

Work on the electrical equipment should only be performed by service personnel. First disconnect the washer from the main power. Do not switch the washer on again until the cause of the fault has been identified.

WARNING:

Turn off the main switch on the dishwasher so it is isolated from the power supply

Before calling for service on your Glasswasher please check that:

- Wash arms are clean and free to rotate.
- Scrap screens are properly positioned and clean.
- Sanitizer, detergent and rinse aid bottles have an adequate level.
- All plumbing valves are open.
- Electrical power to unit is ON.

Problem	Cause	Remedy
Machine will not start	No Power (Power light off) Tripped circuit breaker Door(s) not closed Start switch not depressed long enough Defective door switch (s) Defective start switch(s)	Check power source Reset breaker in customer breaker panel Close door(s) fully. Hold start switch for 3 seconds Check and replace if necessary Check and replace if necessary
Low or no water	Main water supply is turned off Drain valve not seated and open	Turn on water supply Seat drain valve. Check for foreign matter on drain seat
Machine will not fill Low or no water	Closed water supply valve Plugged line strainer Drain valve open Defective fill valve Defective Timer	Open valve Remove and clean screen Check seat for food particles Check and replace if necessary Check and replace if necessary
Water leaking out the door	Spray arms not rotating Spray arm clean out caps not in place or loose No dish rack in machine	Remove and clean arm, shaft, and bushing Reinstall caps and hand tighten Place rack in machine
Machine overfills Fill level is to bottom edge of back wall Do not under fill	Supply water pressure too high Defective fill valve Defective drain solenoid Defective timer	Adjust supply water pressure to 22 -24 psig Do not under fill. Check and replace as necessary Check and replace as necessary. Check and replace as necessary
Scrap trap overflowing	Scrap screen full Scrap tray screen plugged Scrap tray tank drain line plugged Check water level for over filling	Must be kept clean and in place Clean scrap tray screen Clean out drain line Adjust water level
Water temperature is too low when in use	Incoming water temperature at machine too low	Raise temperature of incoming water to machine. (120°F min 140°F recommended)

TROUBLESHOOTING

Problem	Cause	Remedy
Poor washing results	Clogged spray nozzles and dirty sump tank Spray arm not revolving Low water level Poor water conditions Detergent container empty Detergent setting to low Wash water temperature too low Ware being improperly placed in rack Improperly cleaned equipment	Clean wash arm and unit Remove and clean arm, shaft, and bushing Adjust fill to proper level Have filter or softener installed Fill container Contact detergent supplier Check incoming water temperature Use proper racks do not overload racks Clean and delime
Glasses slimy or soapy at end of cycle	Sanitizer feed line in detergent container Improper Rinse Aid setting	Clean line and place in proper container Adjust chemical setting
Insufficient pumped spray pressure	Clogged spray arm Partially plugged pump inlet screen	Clean spray arm and nozzles Clean pump inlet screen
Detergent, sanitizer and/or rinse-aid not feeding properly	Chemical container is empty Feed tubes to/from pumps clogged Tubing kinked or split Feed lines will not fill	Refill or replace container(s) Clean obstruction and flush with hot water or replace tubing Straighten or replace tubing Replace defective parts: Note the detergent, sanitizer, or Rinse Aid advances in the line on each rotation of the pump. The product should hold position when the pump is off. If the product falls back toward the supply one or more of the following may exist. Debris in the pump Split feed line Bad pump tube Replace parts as necessary.

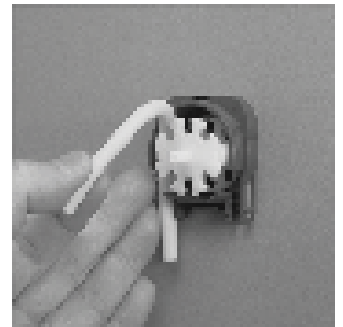
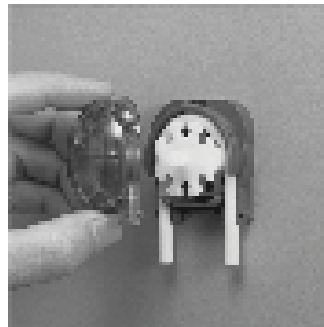
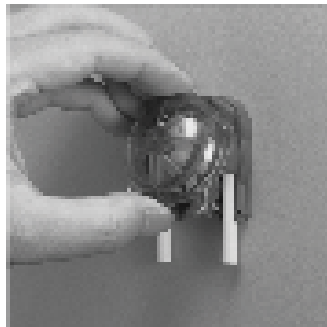
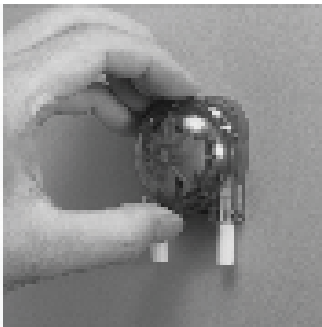

Detergent, Sanitizer and Rinse-aid pump squeeze tube replacement. Design eliminates the need for tools and enables easy cap removal and tube replacement.

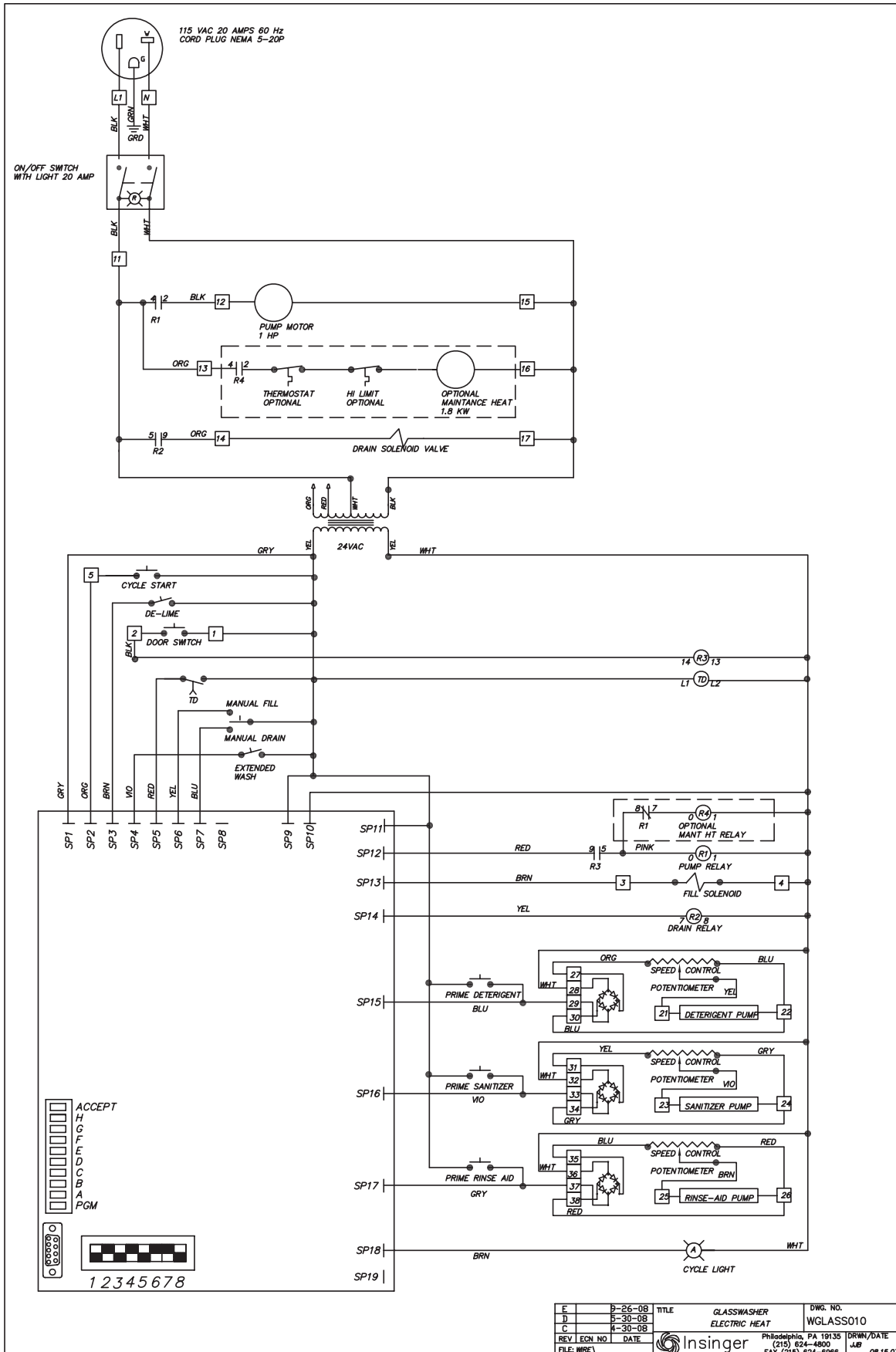

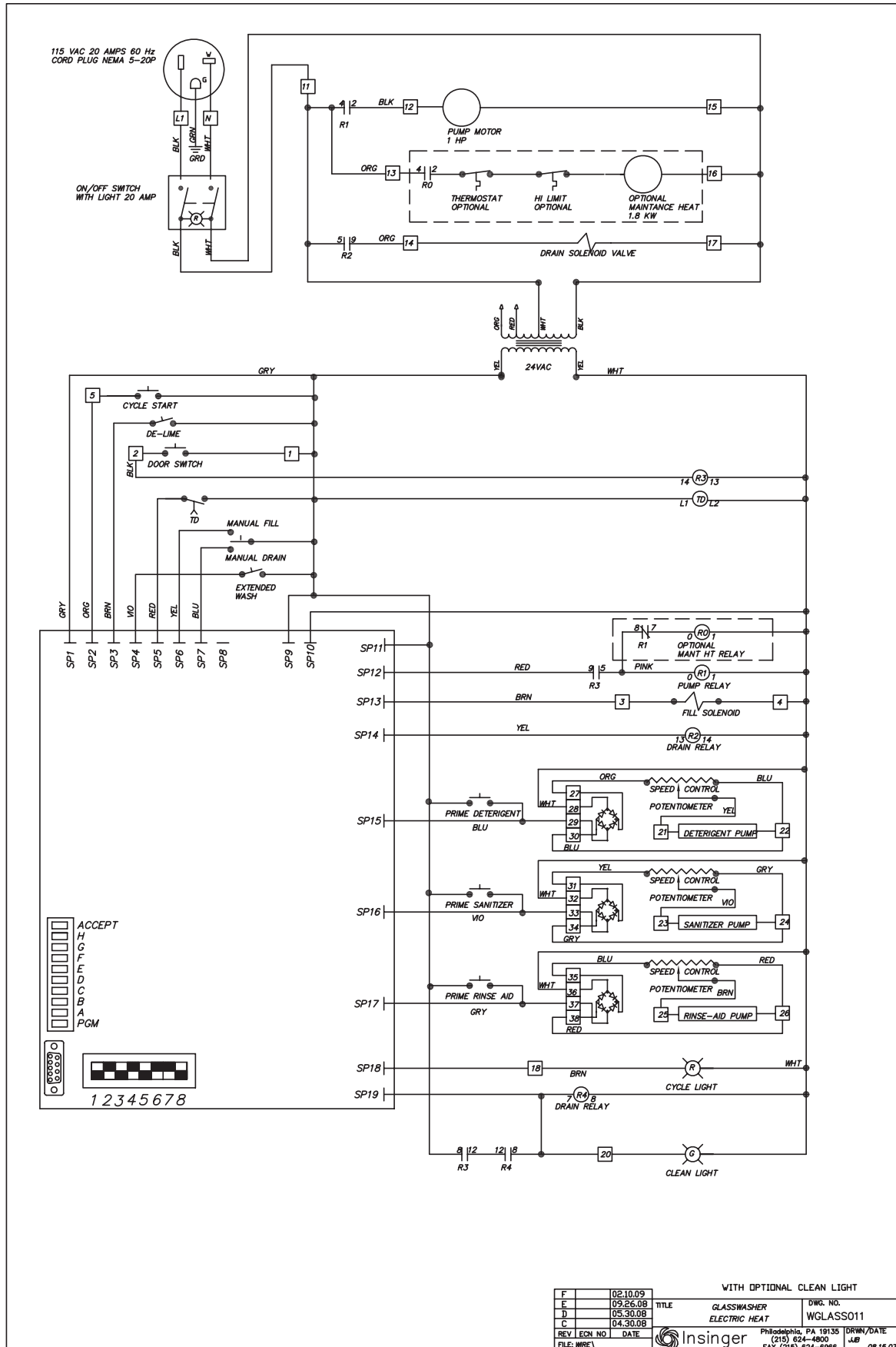

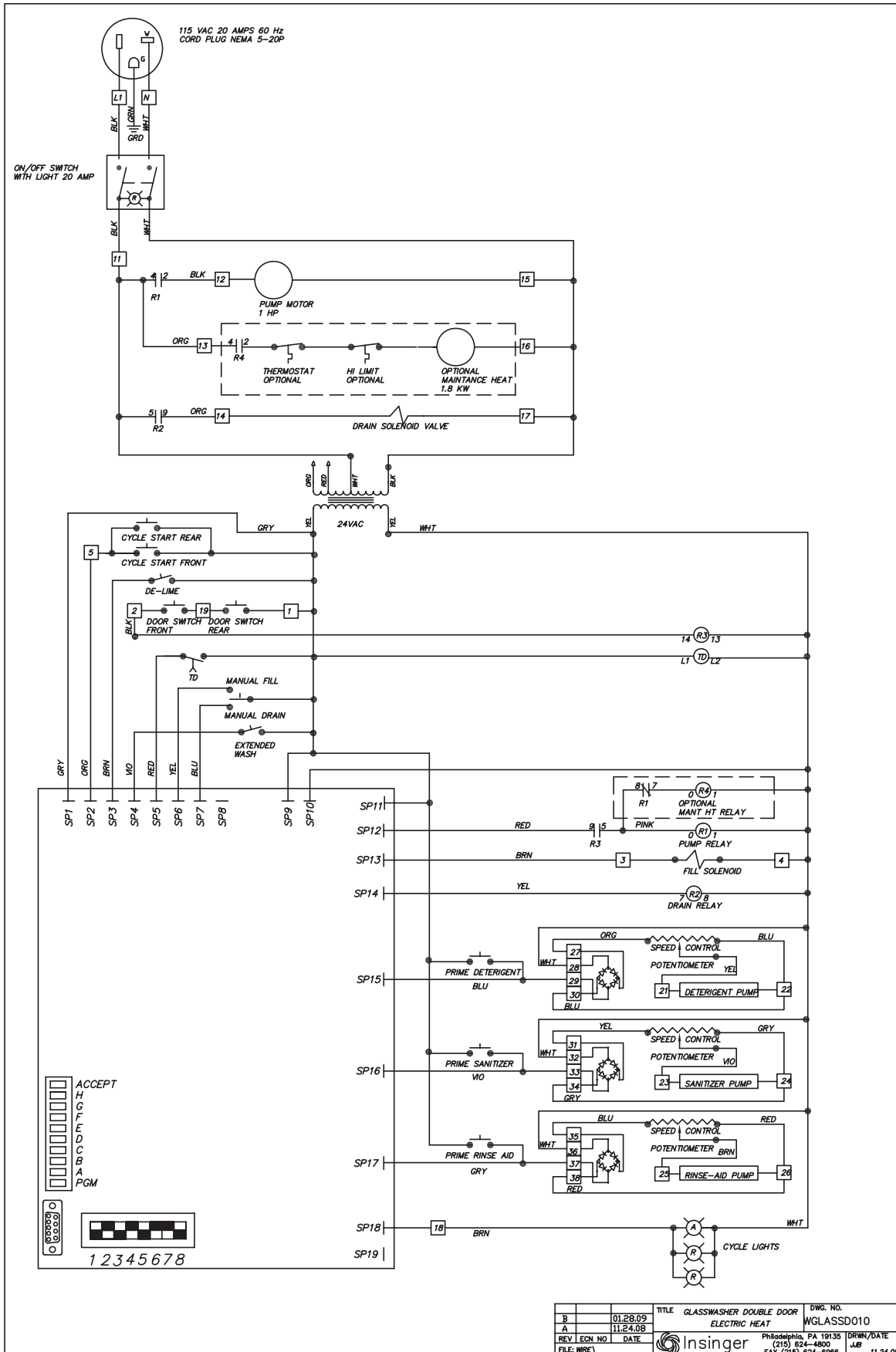

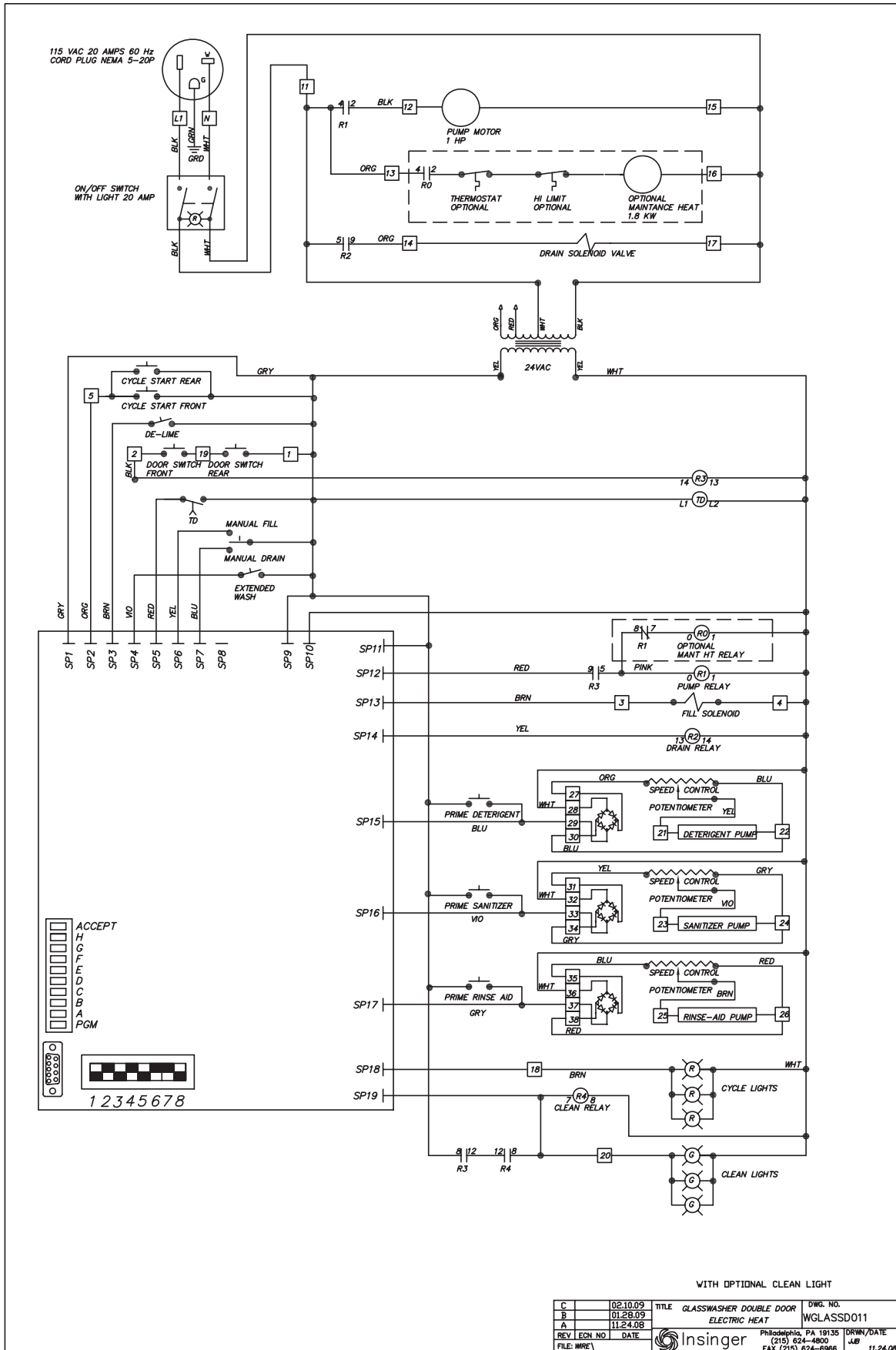

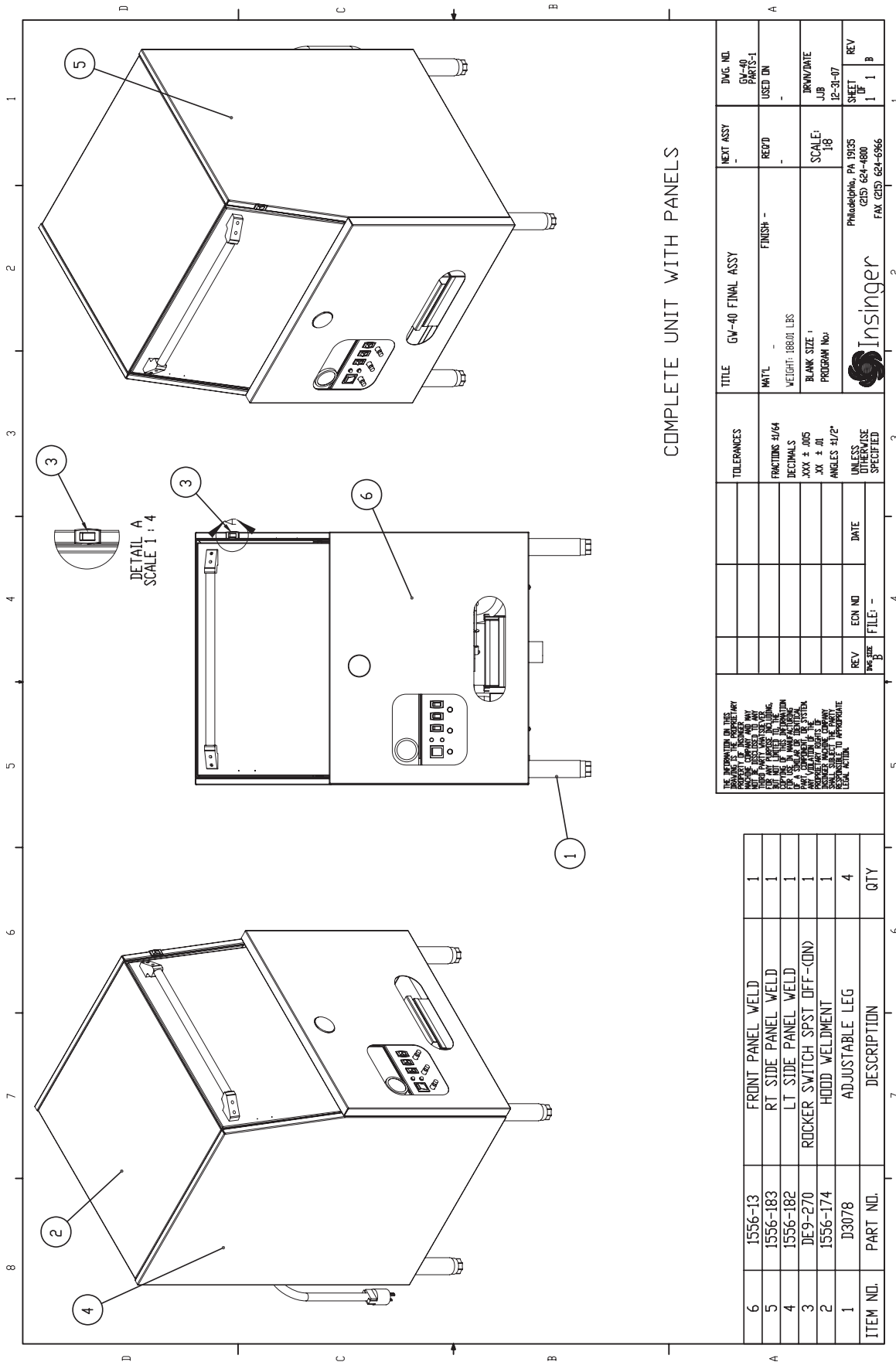

TOLERANCES	TITLE	NEXT ASSY	DWG. NO.
FRACTIONS 3/164	GW-40 FINAL ASSY	-	GW-40 PARTS-1
DECIMALS	MATL	REC'D	USED ON
XXX ± .005	WEIGHT: 180.00 LBS	-	-
XX ± .01	BLANK SIZE:	SCALE:	TRW/DATE
ANGLES ±1/2°	PROGRAM No:	1/8	J.B
UNLESS OTHERWISE SPECIFIED		Philadelphia, PA 19135	SHEET
		(215) 624-4800	OF
		FAX (215) 624-6966	1 1 B

ITEM NO.	PART NO.	DESCRIPTION	QTY
6	1556-13	FRONT PANEL WELD	1
5	1556-183	RT SIDE PANEL WELD	1
4	1556-182	LT SIDE PANEL WELD	1
3	DE9-270	ROCKER SWITCH SPST OFF-ON	1
2	1556-174	HOOD WELDMENT	1
1	D3078	ADJUSTABLE LEG	4

THIS DRAWING IS THE PROPERTY OF INSINGER MACHINE COMPANY. IT IS TO BE USED ONLY FOR THE MANUFACTURE OF THE EQUIPMENT SPECIFIED HEREON. IT IS NOT TO BE REPRODUCED, COPIED, OR TRANSMITTED IN ANY FORM OR BY ANY MEANS, ELECTRONIC OR MECHANICAL, INCLUDING PHOTOCOPYING, RECORDING, OR BY ANY INFORMATION STORAGE AND RETRIEVAL SYSTEM. INSINGER MACHINE COMPANY ACCEPTS NO LIABILITY FOR LOSS OF OR DAMAGE TO THIS DRAWING OR FOR ANY CONSEQUENCES ARISING FROM THE USE OF THIS DRAWING IN ANY MANNER NOT INTENDED BY INSINGER MACHINE COMPANY.

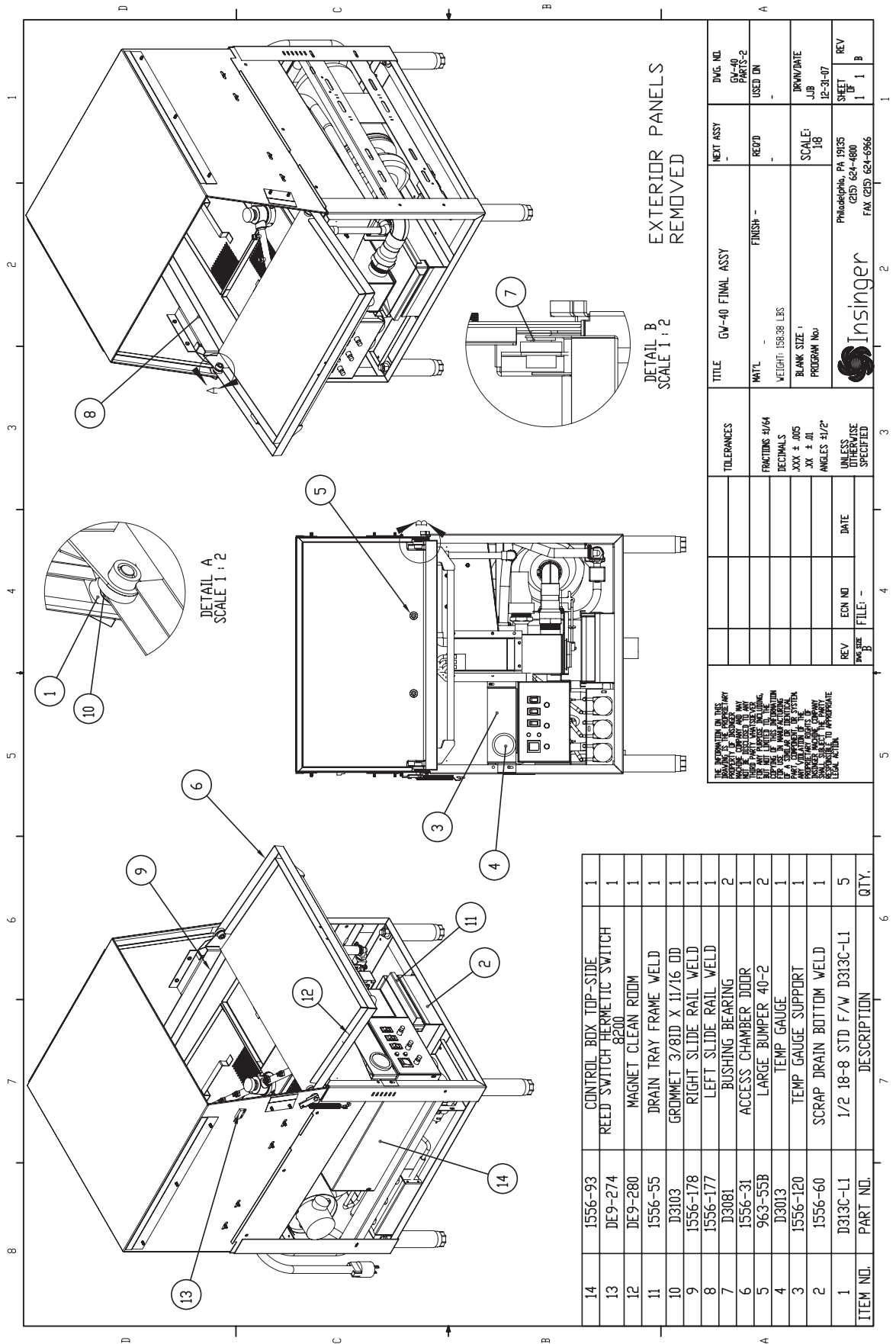

REV	DATE	ECN NO	FILE
REV B			
THE INFORMATION ON THIS DRAWING IS PROPRIETARY AND NOT BE LOANED, REPRODUCED, COPIED, REPRODUCED, OR TRANSMITTED IN ANY MANNER WITHOUT THE WRITTEN PERMISSION OF INSINGER MACHINE COMPANY. ANY VIOLATION OF THIS POLICY WILL BE PROSECUTED TO THE FULL EXTENT OF THE LAW.			
UNLESS OTHERWISE SPECIFIED		TOLERANCES	
FRACTIONS ±1/64 DECIMALS .XXX ± .005 .XX ± .01 ANGLES ±1/2°		TITLE	
GV-40 FINAL ASSY		FINISH -	
WEIGHT: 15838 LBS		MATERIAL	
BLANK SIZE 1		SCALE: 1/8"	
PROGRAM NO:		IRW/DATE	
JJB		USED ON	
12-31-07		DWG. NO.	
SHEET 1		PARTS-2	
REV 1		IRW/DATE	
12-31-07		JJB	
SHEET 1		DWG. NO.	
REV 1		PARTS-2	

ITEM NO.	PART NO.	DESCRIPTION	QTY.
14	1556-93	CONTROL BOX TOP-SIDE	1
13	DE9-274	REED SWITCH HERMETIC SWITCH 8200	1
12	DE9-280	MAGNET CLEAN ROOM	1
11	1556-55	DRAIN TRAY FRAME WELD	1
10	D3103	GROMMET 3/8ID X 11/16 OD	1
9	1556-178	RIGHT SLIDE RAIL WELD	1
8	1556-177	LEFT SLIDE RAIL WELD	1
7	D3081	BUSHING BEARING	2
6	1556-31	ACCESS CHAMBER DOOR	1
5	963-558	LARGE BUMPER 40-2	2
4	D3013	TEMP GAUGE	1
3	1556-120	TEMP GAUGE SUPPORT	1
2	1556-60	SCRAP DRAIN BOTTOM WELD	1
1	D313C-L1	1/2 18-8 STD F/W D313C-L1	5

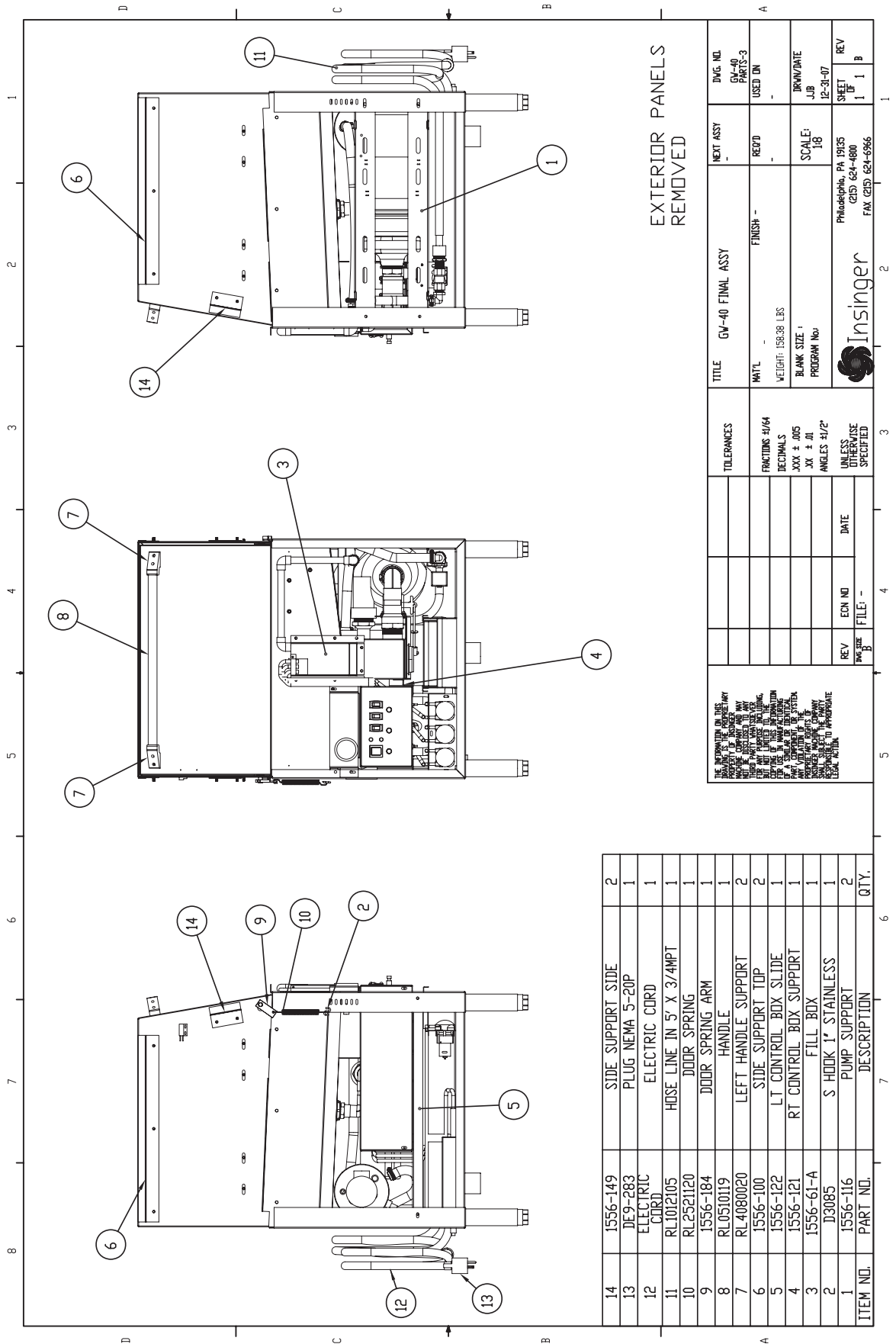

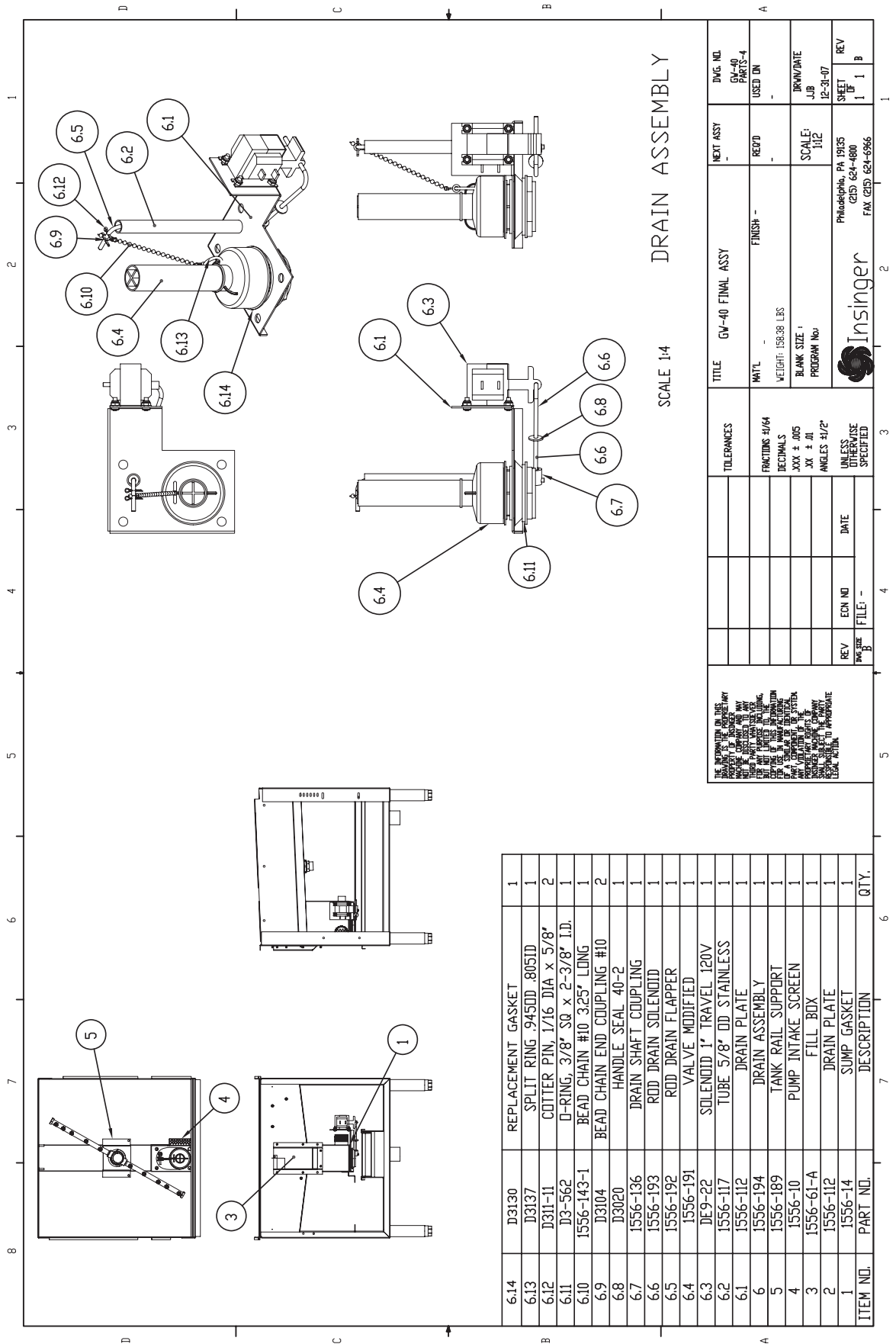

REV	DATE	ECN NO	FILE
1			
2			
3			
4			
5			
6			
7			
8			
9			
10			
11			
12			
13			
14			

ITEM NO.	PART NO.	DESCRIPTION	QTY.
6.14	D3130	REPLACEMENT GASKET	1
6.13	D3137	SPLIT RING .9450D .8051D	1
6.12	D311-11	COTTER PIN, 1/16 DIA x 5/8"	2
6.11	D3-562	O-RING, 3/8" SQ x 2-3/8" I.D.	1
6.10	1556-143-1	BEAD CHAIN #10 3.25" LONG	1
6.9	D3104	BEAD CHAIN END COUPLING #10	2
6.8	D3020	HANDLE SEAL 40-2	1
6.7	1556-136	DRAIN SHAFT COUPLING	1
6.6	1556-193	ROD DRAIN SOLENOID	1
6.5	1556-192	ROD DRAIN FLAPPER	1
6.4	1556-191	VALVE MODIFIED	1
6.3	DE9-22	SOLENOID, 1" TRAVEL, 120V	1
6.2	1556-117	TUBE 5/8" OD STAINLESS	1
6.1	1556-112	DRAIN PLATE	1
5	1556-194	DRAIN ASSEMBLY	1
4	1556-189	TANK RAIL SUPPORT	1
3	1556-10	PUMP INTAKE SCREEN	1
2	1556-61-A	FILL BOX	1
1	1556-112	DRAIN PLATE	1
	1556-14	SUMP GASKET	1
		DESCRIPTION	QTY.

THE INFORMATION ON THIS DRAWING IS PROPRIETARY TO INSINGER MACHINE COMPANY AND IS NOT TO BE REPRODUCED OR TRANSMITTED IN ANY FORM OR BY ANY MEANS, ELECTRONIC OR MECHANICAL, INCLUDING PHOTOCOPYING, RECORDING, OR BY ANY INFORMATION STORAGE AND RETRIEVAL SYSTEM, WITHOUT THE WRITTEN PERMISSION OF INSINGER MACHINE COMPANY. INSINGER MACHINE COMPANY IS NOT RESPONSIBLE FOR ANY DAMAGE TO PERSONS OR PROPERTY ARISING FROM THE USE OF THIS DRAWING.

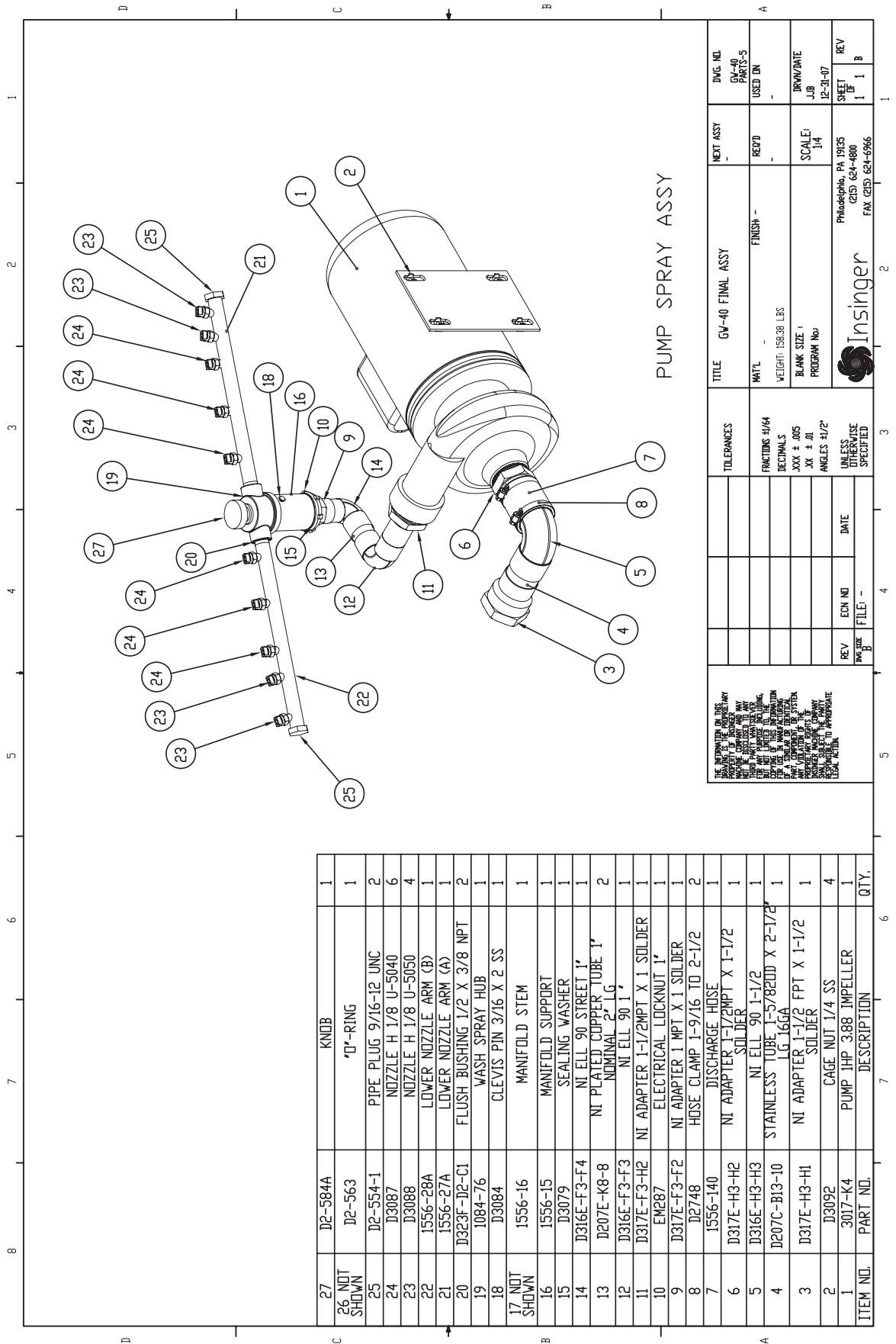

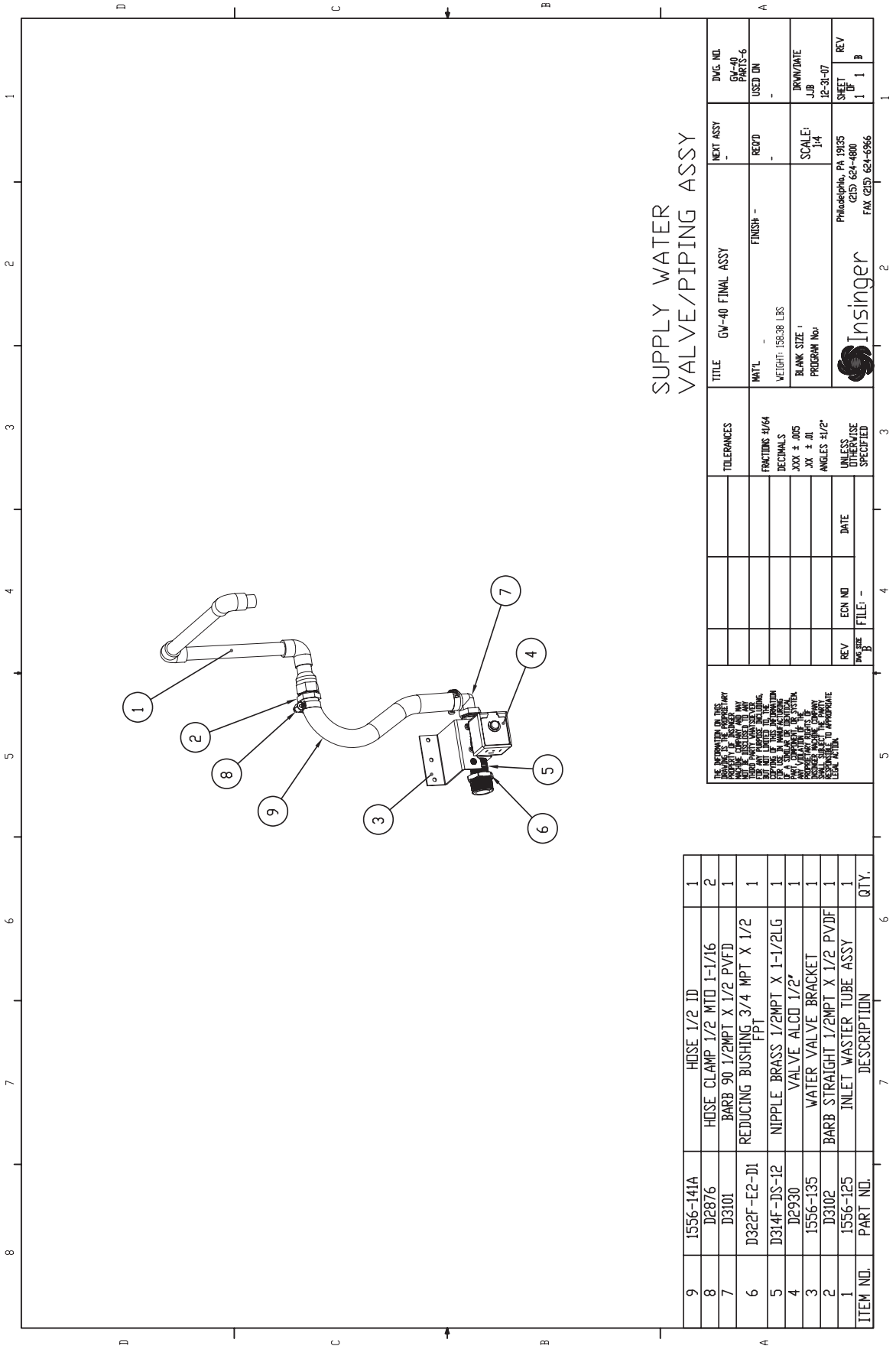
SUPPLY WATER VALVE/PIPING ASSY

ITEM NO.	PART NO.	DESCRIPTION	QTY.
9	I556-141A	HOSE 1/2 ID	1
8	D2876	HOSE CLAMP 1/2 MTD 1-1/16	2
7	D3101	BARB 90 1/2MPT X 1/2 PVFD	1
6	D322F-E2-D1	REDUCING BUSHING 3/4 MPT X 1/2 FPT	1
5	D314F-DS-12	NIPPLE BRASS 1/2MPT X 1-1/2LG	1
4	D2930	VALVE ALCOD 1/2"	1
3	I556-135	WATER VALVE BRACKET	1
2	D3102	BARB STRAIGHT 1/2MPT X 1/2 PVDF	1
1	I556-125	INLET WASTER TUBE ASSY	1
		DESCRIPTION	

THE INFORMATION ON THIS DRAWING IS PROPRIETARY TO INSINGER. IT IS TO BE USED ONLY FOR THE PROJECT AND NOT TO BE REPRODUCED OR TRANSMITTED IN ANY FORM OR BY ANY MEANS, ELECTRONIC OR MECHANICAL, INCLUDING PHOTOCOPYING, RECORDING, OR BY ANY INFORMATION STORAGE AND RETRIEVAL SYSTEM. WITHOUT THE WRITTEN PERMISSION OF INSINGER, THIS DRAWING IS TO BE USED ONLY FOR THE PROJECT AND NOT TO BE REPRODUCED OR TRANSMITTED IN ANY FORM OR BY ANY MEANS, ELECTRONIC OR MECHANICAL, INCLUDING PHOTOCOPYING, RECORDING, OR BY ANY INFORMATION STORAGE AND RETRIEVAL SYSTEM.

REV	DATE
REV B	
ECON NO	FILE

TOLERANCES
FRACTIONS ±1/64
DECIMALS
.XXX ± .005
.XX ± .01
ANGLES ±1/2°
UNLESS OTHERWISE SPECIFIED

TITLE	GV-40 FINAL ASSY	NEXT ASSY	DWG. NO.
MAT'L	FINISH -	REQ'D	GV-40 PARTS-6
WEIGHT: 15838 LBS			USED ON
BLANK SIZE: 1			
PROGRAM NO:	SCALE: 1/4		TRW/DATE
			JJB
			12-31-07
			SHEET
			OF
			1
			1
			B

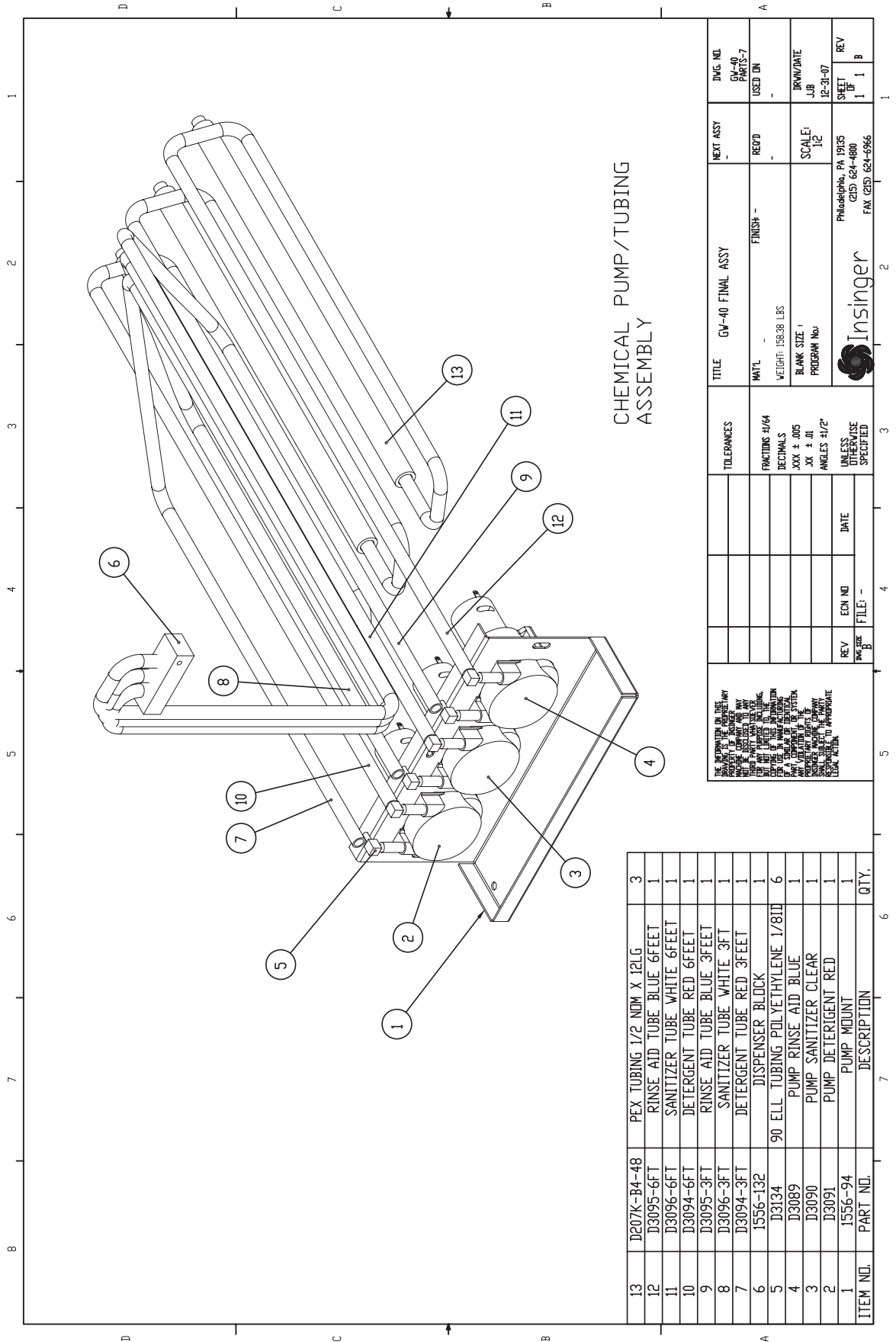

Philadelphia, PA 19135
 (215) 624-4800
 FAX (215) 624-6966

**CHEMICAL PUMP/TUBING
ASSEMBLY**

ITEM NO.	PART NO.	DESCRIPTION	QTY.
13	D207K-B4-48	PEX TUBING 1/2 NDM X 12LG	3
12	D3095-6FT	RINSE AID TUBE BLUE 6FEET	1
11	D3096-6FT	SANITIZER TUBE WHITE 6FEET	1
10	D3094-6FT	DETERGENT TUBE RED 6FEET	1
9	D3095-3FT	RINSE AID TUBE BLUE 3FEET	1
8	D3096-3FT	SANITIZER TUBE WHITE 3FT	1
7	D3094-3FT	DETERGENT TUBE RED 3FEET	1
6	1556-132	DISPENSER BLOCK	1
5	D3134	90 ELL TUBING POLYETHYLENE 1/8ID	6
4	D3089	PUMP RINSE AID BLUE	1
3	D3090	PUMP SANITIZER CLEAR	1
2	D3091	PUMP DETERGENT RED	1
1	1556-94	PUMP MOUNT	1
		DESCRIPTION	

THE INFORMATION ON THIS DRAWING IS UNLESS OTHERWISE SPECIFIED IS THE PROPERTY OF INSINGER MACHINE COMPANY AND IS NOT TO BE REPRODUCED OR TRANSMITTED IN ANY FORM OR BY ANY MEANS, ELECTRONIC OR MECHANICAL, INCLUDING PHOTOCOPYING, RECORDING, OR BY ANY INFORMATION STORAGE AND RETRIEVAL SYSTEM. ANY UNAUTHORIZED REPRODUCTION OR TRANSMISSION OF THIS DRAWING IS STRICTLY PROHIBITED. INSINGER MACHINE COMPANY SHALL BE RESPONSIBLE FOR ANY ERRORS OR OMISSIONS.

REV	DATE	ECN NO	FILE
B			
A			

TOLERANCES	FRACTIONS ±1/64	DECIMALS .XXX ± .005	ANGLES ±1/2°
	UNLESS OTHERWISE SPECIFIED		
TITLE	GW-40 FINAL ASSY		
MAT'L	FINISH -		
WEIGHT: 158.38 LBS			
BLANK SIZE: 1			
PROGRAM NO:			
SCALE: 1/2			
REV	DATE	ECN NO	FILE
1	12-31-07		

INSINGER	Philadelphia, PA 19105
	(215) 624-4800
	FAX (215) 624-6966

REV	SHEET	OF
1	1	1

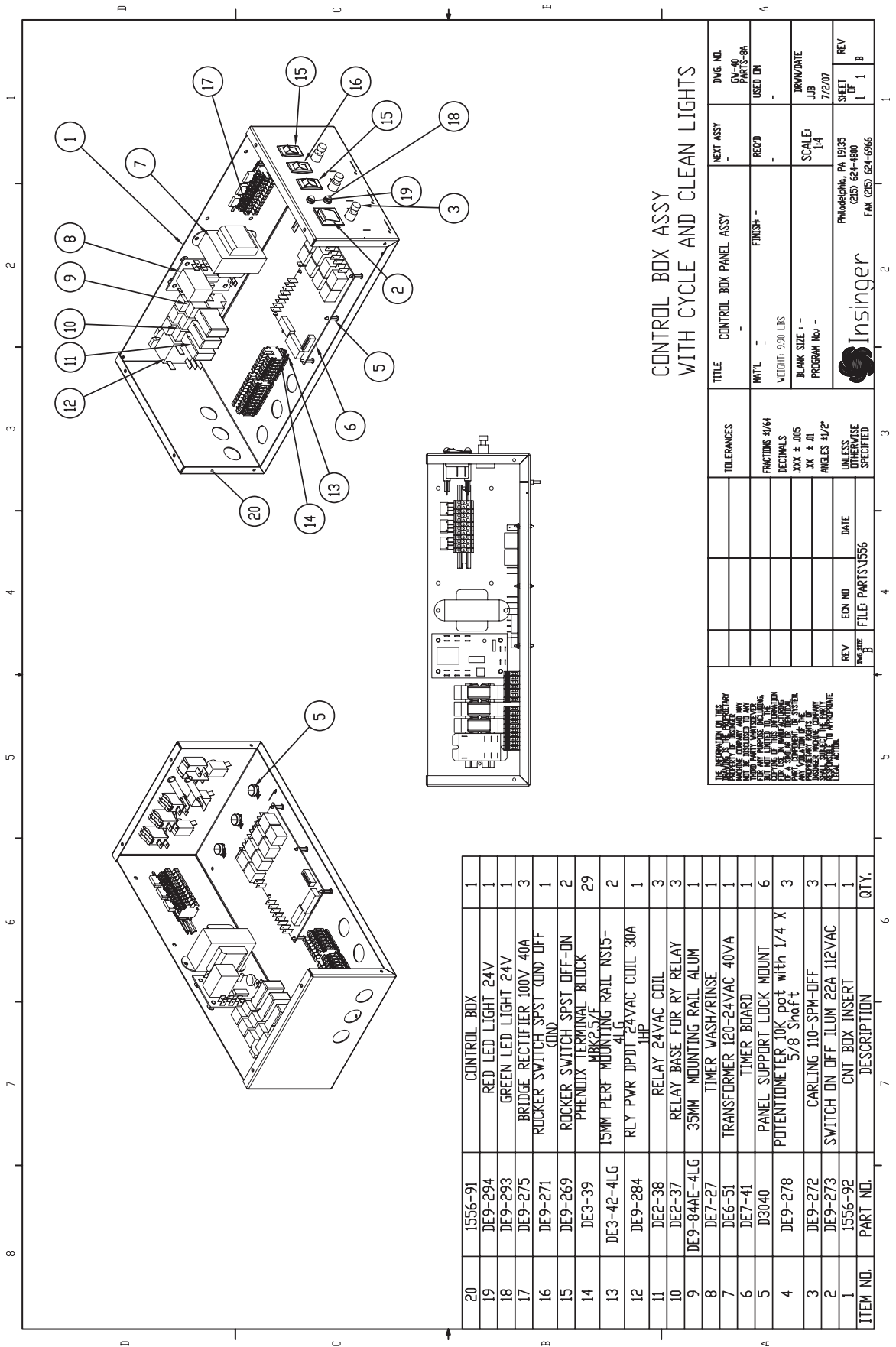
**CONTROL BOX ASSY
WITH CYCLE AND CLEAN LIGHTS**

ITEM NO.	1	2	3	4	5	6	7	8
PART NO.	1556-92							
DESCRIPTION	CNT BOX INSERT							
	SWITCH ON OFF ILLUM 22A 112VAC							
	POTENTIOMETER 10K pot with 1/4 X 5/8 Shaft							
	PANEL SUPPORT LOCK MOUNT							
	TRANSFORMER 120-24VAC 40VA							
	TIMER BOARD							
	RELAY BASE FOR RY RELAY							
	35MM MOUNTING RAIL ALUM							
	RELAY 24VAC COIL							
	RELAY PWR DPDT 24VAC COIL 30A 1HP							
	15MM PERF MOUNTING RAIL NS15-4LG							
	PHENOX TERMINAL BLOCK MK2.5/E							
	ROCKER SWITCH SPST OFF-ON							
	BRIDGE RECTIFIER 100V 40A							
	GREEN LED LIGHT 24V							
	RED LED LIGHT 24V							
	CONTROL BOX							
QTY.	1	1	1	1	1	1	1	1

THE INFORMATION ON THIS DRAWING IS PROPRIETARY TO INSINGER MACHINE COMPANY AND IS NOT TO BE REPRODUCED OR TRANSMITTED IN ANY FORM OR BY ANY MEANS, ELECTRONIC OR MECHANICAL, INCLUDING PHOTOCOPYING, RECORDING, OR BY ANY INFORMATION STORAGE AND RETRIEVAL SYSTEM. ANY UNAUTHORIZED USE OF THIS DRAWING IS PROHIBITED. INSINGER MACHINE COMPANY SHALL BE HELD HARMLESS FOR ANY SUCH ACTION.

REV	DATE	ECN NO	FILE: PARTS\1556
B			

TOLERANCES	FRACTIONS #1/64	DECIMALS	.XXX ± .005
			.XX ± .01
			ANGLES ±1/2°
			UNLESS OTHERWISE SPECIFIED

TITLE	CONTROL BOX PANEL ASSY	FINISH	-
WEIGHT	9.90 LBS		
BLANK SIZE	1 -	SCALE	1/4
PROGRAM NO	-	DRW/DATE	JJB 7/2/07
INSINGER	Phoenicia, PA 19355		
	CEP 624-4800		
	PAK CEP 624-6966		
REV	SHEET	REV	REV
1	1	1	1

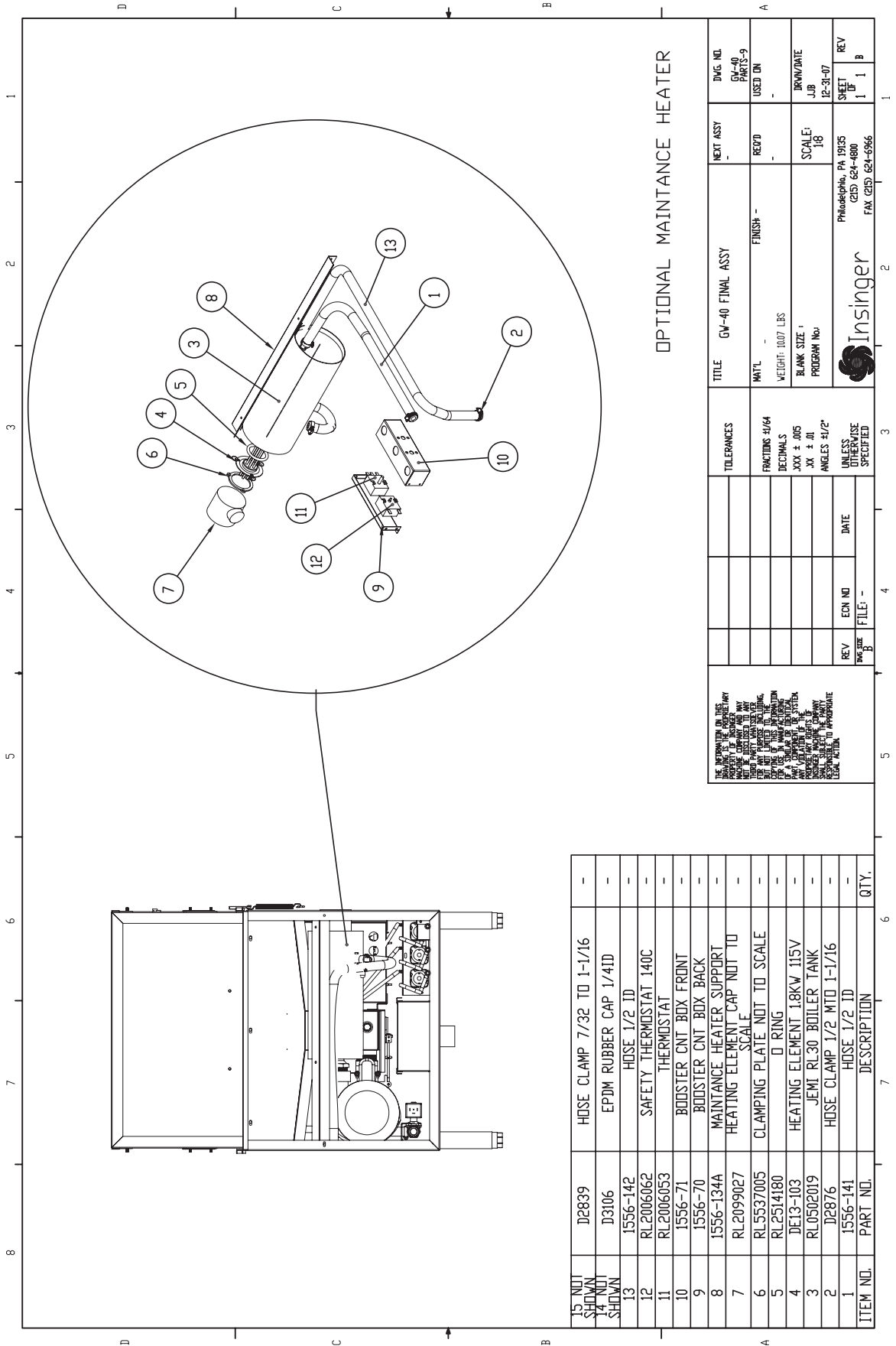
OPTIONAL MAINTAINANCE HEATER

ITEM NO.	PART NO.	DESCRIPTION	QTY.
15	D2839	HOSE CLAMP 7/32 TO 1-1/16	-
14	D3106	EPDM RUBBER CAP 1/4ID	-
13	1556-142	HOSE 1/2 ID	-
12	RL2006062	SAFETY THERMOSTAT 140C	-
11	RL2006053	THERMOSTAT	-
10	1556-71	BOOSTER CNT BOX FRONT	-
9	1556-70	BOOSTER CNT BOX BACK	-
8	1556-134A	MAINTAINANCE HEATER SUPPORT	-
7	RL2099027	HEATING ELEMENT CAP NUT TO SCALE	-
6	RL5537005	CLAMPING PLATE NUT TO SCALE	-
5	RL2514180	O RING	-
4	DE13-103	HEATING ELEMENT 1.8KW 115V	-
3	RL0502019	JEMI RL30 BOILER TANK	-
2	D2876	HOSE CLAMP 1/2 MTD 1-1/16	-
1	1556-141	HOSE 1/2 ID	-
		DESCRIPTION	

THE INFORMATION ON THIS DRAWING IS THE PROPERTY OF INSINGER MACHINE COMPANY AND WILL BE KEPT CONFIDENTIAL. NO PART OF THIS DRAWING IS TO BE REPRODUCED OR TRANSMITTED IN ANY FORM OR BY ANY MEANS, ELECTRONIC OR MECHANICAL, INCLUDING PHOTOCOPYING, RECORDING, OR BY ANY INFORMATION STORAGE AND RETRIEVAL SYSTEM, WITHOUT THE WRITTEN PERMISSION OF INSINGER MACHINE COMPANY. SPECIAL NOTE: TO APPROPRIATE LOCAL AGENCIES.

TOLERANCES	TITLE	NEXT ASSY	DWG. NO.
FRACTIONS #1/64 DECIMALS .XXX ± .005 .XX ± .01 ANGLES #1/2°	GW-40 FINAL ASSY	-	CL-10 PARTS-9
UNLESS OTHERWISE SPECIFIED	MAT'L	REC'D	USED UN
	WEIGHT: 1007 LBS		
	BLANK SIZE 1	SCALE: 1/8	DRW/DATE
	PROGRAM NO.		JJB 12-31-07
			SHEET
			1 1
			REV
			1 1



Philadelphia, PA 19135
 (215) 624-4800
 FAX (215) 624-6966

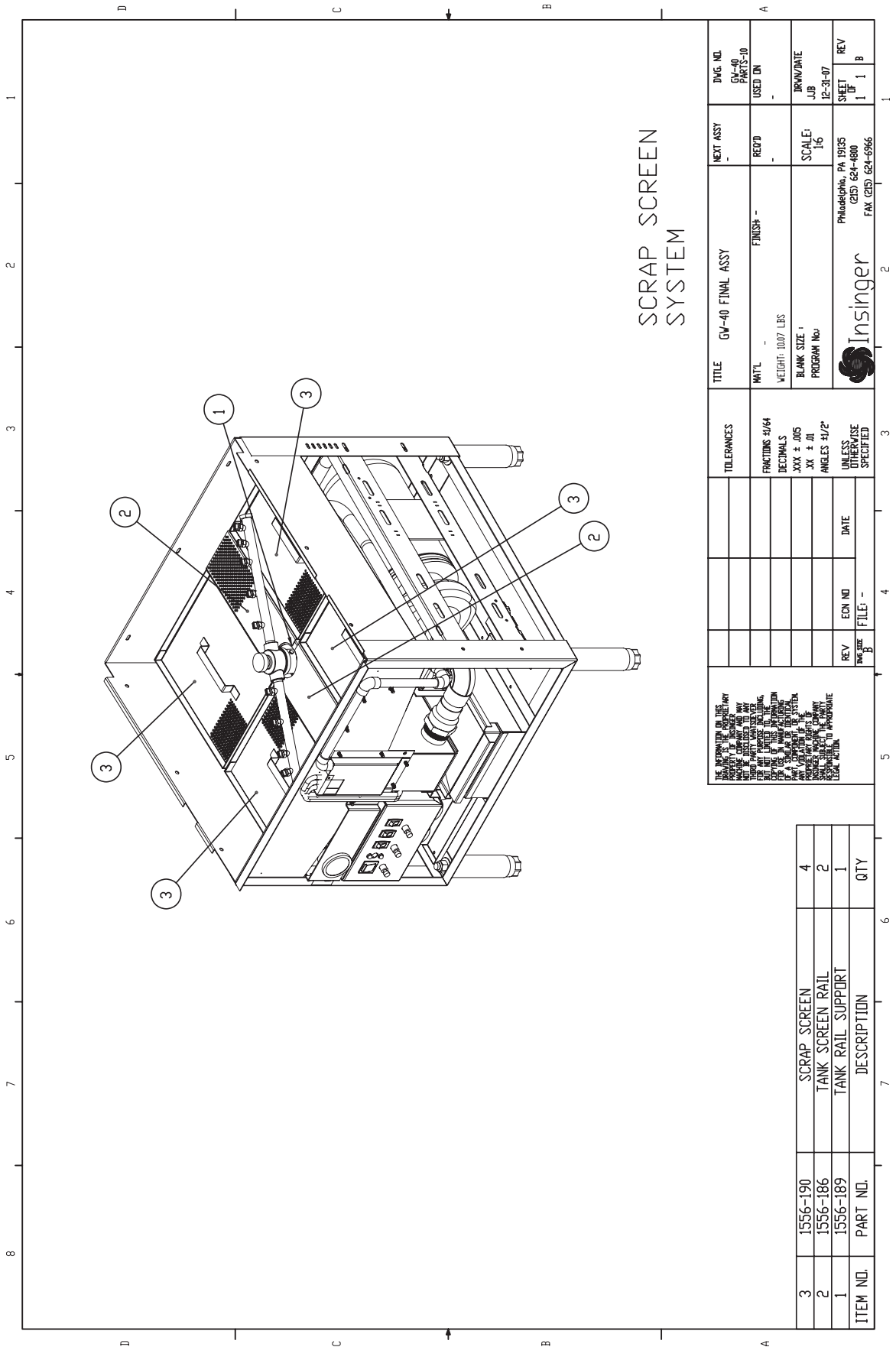

3	1556-190	SCRAP SCREEN	4	QTY
	2	1556-186	TANK SCREEN RAIL	2
1	1556-189	TANK RAIL SUPPORT	1	
ITEM NO.	PART NO.	DESCRIPTION		

<p>THE INFORMATION ON THIS DRAWING IS THE PROPERTY OF INSINGER MACHINE COMPANY AND WILL BE KEPT CONFIDENTIAL AND NOT REPRODUCED OR TRANSMITTED IN ANY FORM OR BY ANY MEANS, ELECTRONIC OR MECHANICAL, INCLUDING PHOTOCOPYING, RECORDING, OR BY ANY INFORMATION STORAGE AND RETRIEVAL SYSTEM, WITHOUT THE WRITTEN PERMISSION OF INSINGER MACHINE COMPANY. ANY UNAUTHORIZED REPRODUCTION OR TRANSMISSION OF THIS DRAWING IS PROHIBITED AND WILL BE PROSECUTED TO THE FULL EXTENT OF THE LAW.</p>			
TOLERANCES	FRACTIONS #/64	DECIMALS	ANGLES #/12°
	.XXX ± .005	.XX ± .01	UNLESS OTHERWISE SPECIFIED
REV	DATE	ECN NO	FILE
B			
<p>INSINGER Philadelphia, PA 19155 CEX 624-4800 FAX CEX 624-6966</p>			
<p>SCALE: 1/16</p>		<p>DRWN/DATE JJB 12-31-07</p>	<p>DWG NO. GW-40 PARTS-10</p>
REV	BY	REV	BY
1		1	
2		2	

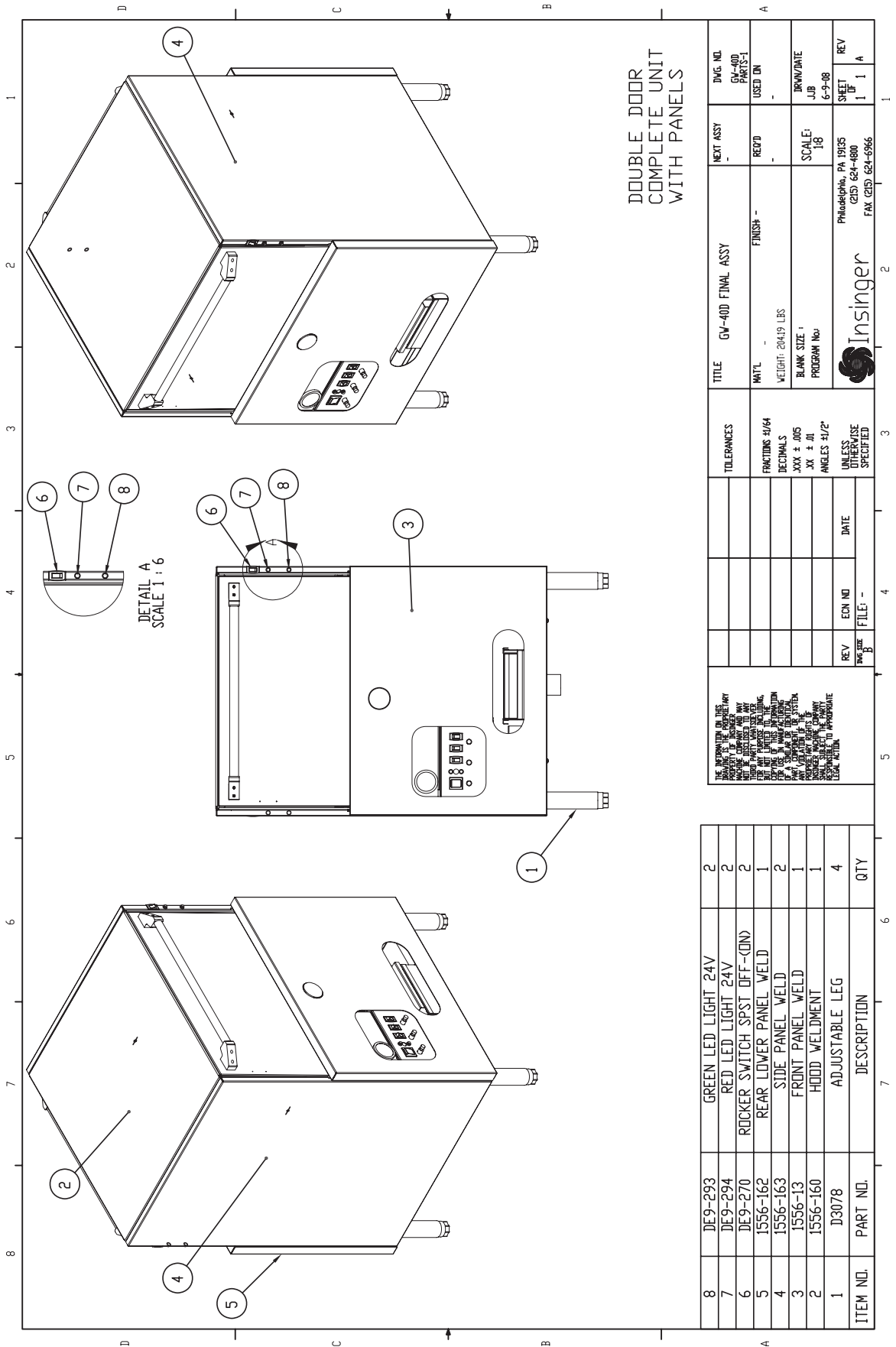

ITEM NO.	PART NO.	DESCRIPTION	QTY
8	DE9-293	GREEN LED LIGHT 24V	2
7	DE9-294	RED LED LIGHT 24V	2
6	DE9-270	ROCKER SWITCH SPST OFF<ON>	2
5	1556-162	REAR LOWER PANEL WELD	1
4	1556-163	SIDE PANEL WELD	2
3	1556-13	FRONT PANEL WELD	1
2	1556-160	HOOD WELDMENT	1
1	D3078	ADJUSTABLE LEG	4
		DESCRIPTION	

TOLERANCES	TITLE	NEXT ASSY	DWG. NO.
FRACTIONS #/64 DECIMALS .XXX ± .005 .XX ± .01 ANGLES #1/2°	GV-40D FINAL ASSY	-	GA-100 PARTS-1
UNLESS OTHERWISE SPECIFIED	MAT'L FINISH --	REC'D	USED UN
	WEIGHT: 28419 LBS		
	BLANK SIZE 1		DRW/DATE
	PROGRAM NO.		JJB 6-9-08
			SCALE: 1/8
			SHEET 1
			REV 1
			FILE: A

REV	DATE	ECN NO	FILE:
B			

THE INFORMATION ON THIS DRAWING IS THE PROPERTY OF INSINGER MACHINE COMPANY AND ANY REPRODUCTION OR TRANSMISSION OF THIS DRAWING IN ANY FORM OR BY ANY MEANS WITHOUT THE WRITTEN PERMISSION OF INSINGER MACHINE COMPANY IS STRICTLY PROHIBITED. INSINGER MACHINE COMPANY SHALL BE HELD RESPONSIBLE FOR ANY ERRORS OR OMISSIONS.

Phoenicia, PA 19155
 (215) 624-4800
 FAX (215) 624-6966

Insinger

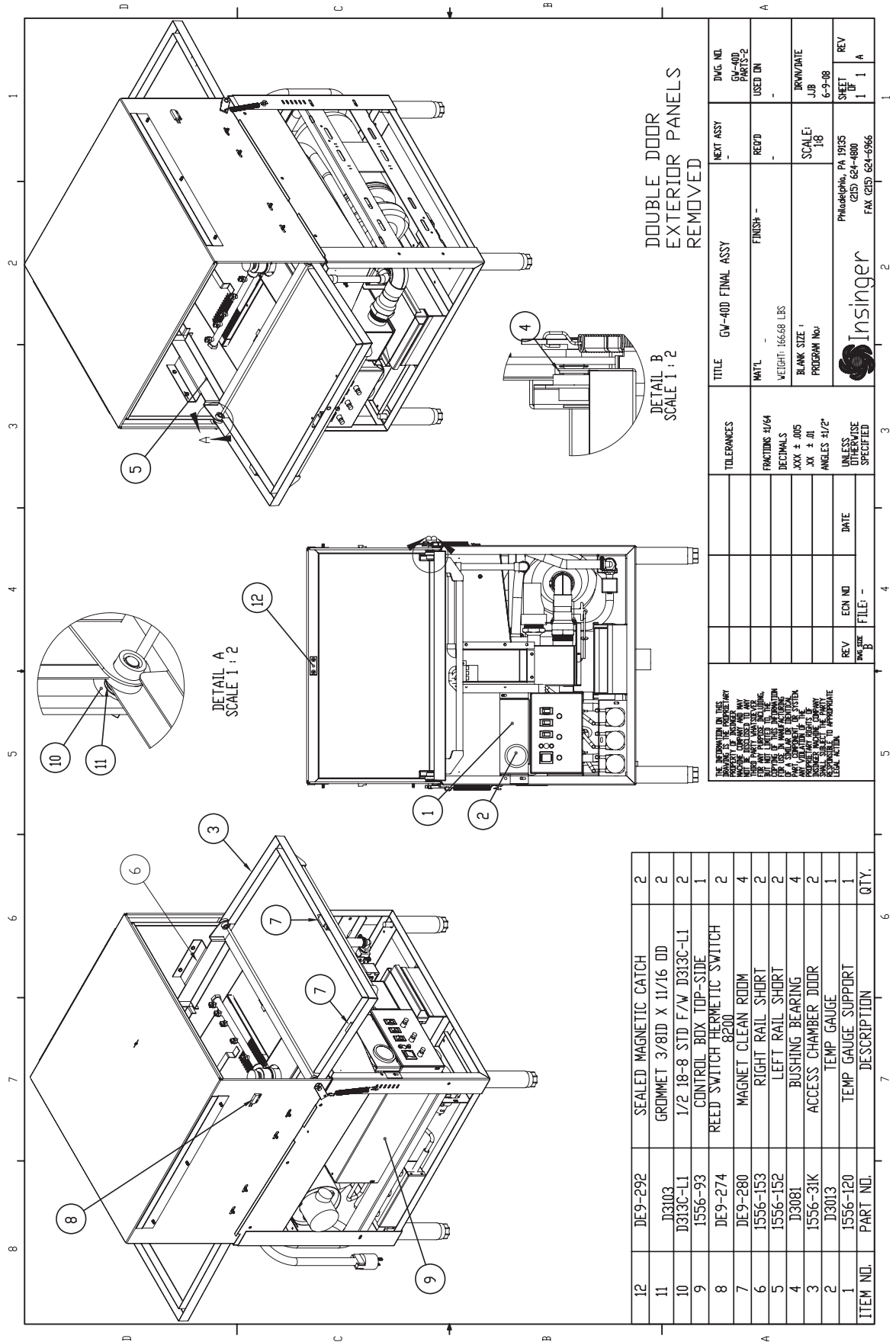

**DOUBLE DOOR
EXTERIOR PANELS
REMOVED**

**DETAIL B
SCALE 1:2**

**DETAIL A
SCALE 1:2**

12	DE9-292	SEALED MAGNETIC CATCH	2	QTY.
11	D3103	GRIMMET 3/8ID X 11/16 OD	2	
10	D313C-L1	1/2 18-8 STD F/W D313C-L1	2	
9	1556-93	CONTROL BOX TOP-SIDE	1	
8	DE9-274	REED SWITCH HERMETIC SWITCH 8200	2	
7	DE9-280	MAGNET CLEAN ROOM	4	
6	1556-153	RIGHT RAIL SHORT	2	
5	1556-152	LEFT RAIL SHORT	2	
4	D3081	BUSHING BEARING	4	
3	1556-31K	ACCESS CHAMBER DOOR	2	
2	D3013	TEMP GAUGE	1	
1	1556-120	TEMP GAUGE SUPPORT	1	
		DESCRIPTION	6	
			7	
			8	
			9	
			10	
			11	
			12	

TOLERANCES	FRACTIONS #1/64	DECIMALS .XXX ± .005	ANGLES #1/2°	UNLESS OTHERWISE SPECIFIED
TITLE	GV-40D FINAL ASSY	FINISH -	RECD	USED UN
WEIGHT	166.68 LBS	BLANK SIZE 1	SCALE: 1/8	DRWN/DATE
PROGRAM NO.				JJB 6-9-08
Phoenicia, PA 19135				SHEET 1
INSINGER				REV 1
				REV A

Phoenicia, PA 19135
 (215) 624-4800
 FAX (215) 624-6966

THE INFORMATION ON THIS DRAWING IS THE PROPERTY OF INSINGER MACHINE COMPANY AND WILL BE KEPT CONFIDENTIAL. NO PART OF THIS DRAWING IS TO BE REPRODUCED OR TRANSMITTED IN ANY FORM OR BY ANY MEANS, ELECTRONIC OR MECHANICAL, INCLUDING PHOTOCOPYING, RECORDING, OR BY ANY INFORMATION STORAGE AND RETRIEVAL SYSTEM, WITHOUT THE WRITTEN PERMISSION OF INSINGER MACHINE COMPANY. THIS DRAWING IS TO BE USED ONLY FOR THE PROJECT SPECIFIED HEREON. ANY OTHER USE IS UNAUTHORIZED.

REV B
 EGN NO
 DATE
 FILE: -

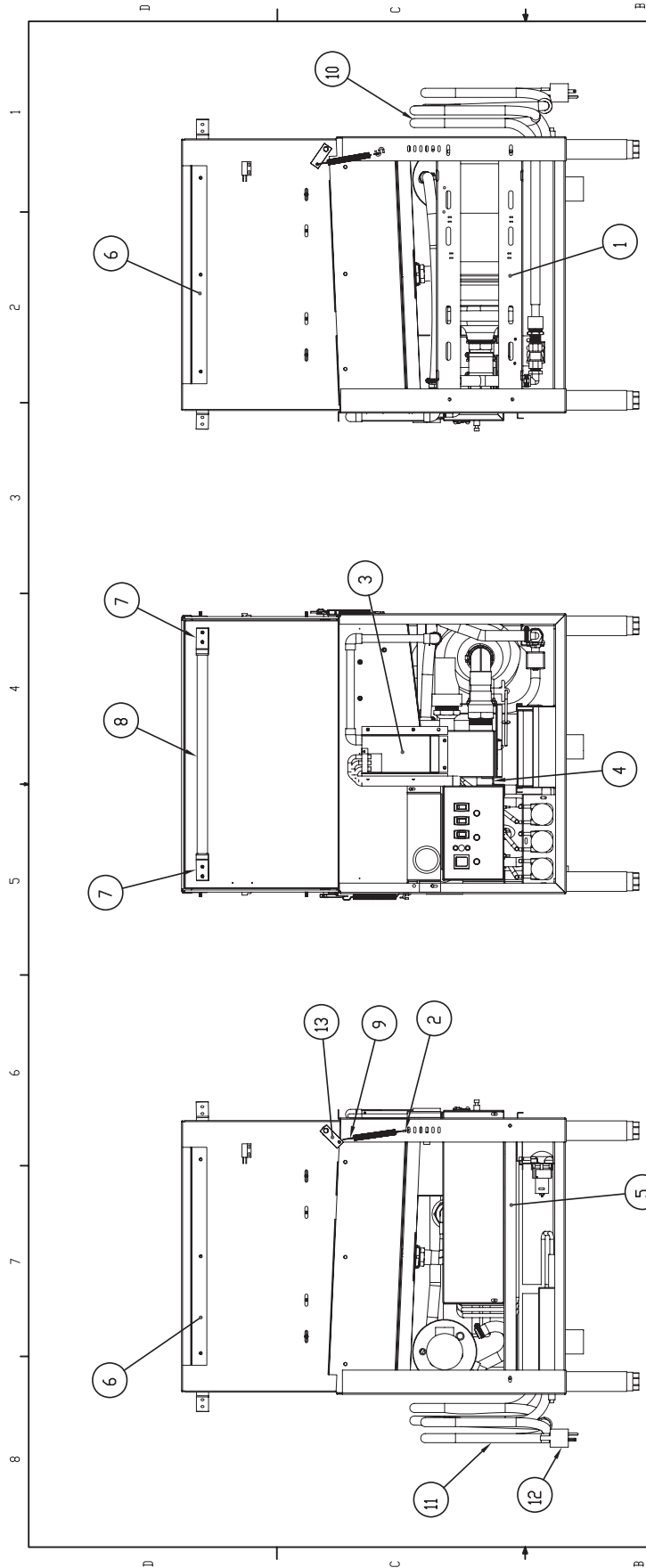
**DOUBLE DOOR
EXTERIOR PANELS
REMOVED**

TITLE		GV-400 FINAL ASSY	DWG. NO.		1
MATERIAL		FINISH --	CLASS		PARTS-3
TOLERANCES		FRACTIONS #/64	USED IN		-
DECIMALS		.XXX ± .005	DRAWN/DATE		JJB
ANGLES #1/2°		UNLESS OTHERWISE SPECIFIED	SCALE:		1/8
REV		ECN NO	DATE		
DWG. SIZE		FILE:	REV		1
INSINGER		Phoenicia, PA 19355		SHEET	
REV		CITY 624-4800		OFF	
REV		FAX (624) 624-6966		1	
REV				A	

THE INFORMATION ON THIS DRAWING IS THE PROPERTY OF INSINGER MACHINE COMPANY AND WILL BE KEPT CONFIDENTIAL. IT IS TO BE USED ONLY FOR THE PURPOSES SPECIFIED. ANY REPRODUCTION OR USE OF THIS DRAWING WITHOUT THE WRITTEN PERMISSION OF INSINGER MACHINE COMPANY IS PROHIBITED. INSINGER MACHINE COMPANY SHALL BE HELD HARMLESS FOR ANY AND ALL DAMAGES, INCLUDING REASONABLE ATTORNEY'S FEES, ARISING OUT OF OR FROM THIS DRAWING.

ITEM NO.	PART NO.	DESCRIPTION	QTY.
13	1556-184	DOOR SPRING ARM	2
12	DE9-283	PLUG NEMA 5-20P	1
11	ELECTRIC CORD	ELECTRIC CORD	1
10	RL1012105	HOSE LINE IN 5' X 3/4MPT	1
9	RL2521120	DOOR SPRING	2
8	RL0510119	HANDLE	2
7	RL41080020	LEFT HANDLE SUPPORT	4
6	1556-100	SIDE SUPPORT TIP	2
5	1556-122	LT CONTROL BOX SLIDE	1
4	1556-121	RT CONTROL BOX SUPPORT	1
3	1556-61-A	FILL BOX	1
2	D30085	S HOOK 1" STAINLESS	2
1	1556-116	PUMP SUPPORT	2
		DESCRIPTION	



Insinger Machine Company
6245 State Road
Philadelphia, PA 19135-2996

800-344-4802
Fax 215-624-6966