



SHERWOOD INDUSTRIES IS AN ENVIRONMENTALLY RESPONSIBLE COMPANY. THIS MANUAL IS PRINTED ON RECYCLED PAPER.

PLEASE KEEP THESE INSTRUCTIONS FOR FUTURE REFERENCE



# EG40 DV

BY: SHERWOOD INDUSTRIES LTD

## OWNER'S MANUAL



### WHAT TO DO IF YOU SMELL GAS

- Open windows/Extinguish any open flame.
- Do not try to light any appliance.
- Do not touch any electrical switch or use any phone in your building.
- Immediately call your gas supplier from a neighbour's phone. Follow the gas supplier's instructions.
- If you cannot reach your gas supplier, call the fire department.

This appliance may be installed in an after market permanently located, manufactured (mobile) home, where not prohibited by local codes.

This appliance is only for use with the type of gas indicated on the rating plate. This appliance is not convertible for use with other gases, unless a certified kit is used.

### WARNING

**If the information in this manual is not followed exactly, a fire or explosion may result causing property damage, personal injury or loss of life. Installation and service must be performed by a qualified installer, service agency or the gas supplier.**

### FOR YOUR SAFETY

**Do not store or use gasoline or other Flammable vapours and liquids in the vicinity of this or any other appliance.**



Massachusetts installations (Warning): This product must be installed by a licensed plumber or gas fitter when installed within the Commonwealth of Massachusetts. Other Massachusetts code requirements:-Flexible connector must not be longer than 36 inches, shut off valve must be a "T" handle gas cock, only direct vent sealed combustion products are approved for bedroom/bathrooms, fireplace dampers must be removed or welded in the open position prior to the installation of a fireplace insert or gas log.

EG40-070

# SAFETY PRECAUTIONS

## FOR SAFE INSTALLATION AND OPERATION OF YOUR “ENVIRO” HEATER, PLEASE CAREFULLY READ THE FOLLOWING INFORMATION:

- All ENVIRO gas-fired appliances must be installed in accordance with their instructions. Carefully read all the instructions in this manual first. Consult the building authority having jurisdiction to determine the need for a permit prior to commencing the installation.
- **NOTE:** Failure to follow these instructions could cause a malfunction of the fireplace, which could result in death, serious bodily injury, and/or property damage.
- Failure to follow these instructions may also void your fire insurance and/or warranty.

### GENERAL

- Installation and repair should be done by a qualified service person. The appliance should be inspected before the first use and, annually thereafter by a qualified service person. More frequent cleaning may be required due to excessive lint from carpeting, bedding material, etc. It is imperative the control compartments, burners and circulating air passageways of the appliance be kept clean.
- Due to high temperatures, the appliance should be located out of high traffic areas and away from furniture and draperies.

**Children and adults should be alerted to the hazards of high surface temperatures and should stay away to avoid burns or clothing ignition.**

**Young children should be carefully supervised when they are in the same room as the appliance.**

### FOR YOUR SAFETY

- Installation and service must be performed by a qualified installer, service agency or gas supplier.
- This installation must conform to local codes or, in the absence of local codes, to the current CAN/CGA-B149 installation code (Canada) or National Fuel Gas Code ANSI Z223.1.2 (USA).
- To prevent injury, do not allow anyone who is unfamiliar with the stove to operate it.

**• To prevent injury, if the pilot or pilot and burners have gone out on their own, open the glass door and wait 5 minutes to air out before attempting to re-light the stove.**

- Always keep the area around this appliance clear of combustible material, gasoline and other flammable liquids and vapours.
- This appliance should not be used as a drying rack for clothing or for hanging Christmas stockings/decorations.
- Due to the paint curing on the stove, a faint odor and slight smoking will likely be noticed when the stove is first used. Open a window until the smoking stops.

Always connect this gas stove to a vent system and vent to the outside of the building envelope. Never vent to another room or inside the building. Make sure the specified vent pipe is used; properly sized and of adequate height to provide sufficient draft. Inspect the venting system annually for blockage and signs of deterioration.

**WARNING:** Failure to position the parts in accordance with the diagrams in this booklet, or failure to use only parts specifically approved with this appliance may result in property damage or personal injury.

**WARNING:** Do not operate with the glass front removed, cracked or broken. Replacement of the glass must be done by a licensed or qualified service person.

- Never use solid fuels such as wood, paper, cardboard, coal, or any flammable liquids, etc., in this appliance.
- Do not use this heater if any part has been under water. Immediately call a qualified service technician to inspect the heater and to replace any part of the control or gas control systems that have been under water.
- Do not abuse the glass by striking it or slamming the door shut.

# TABLE OF CONTENTS

---

Safety Precautions.....	2
Table of Contents.....	3
Codes And Approvals.....	4
Specifications.....	5
Dimensions.....	5
Clearances to Combustibles.....	5
Preparation For Installation:.....	5
Initial Installation.....	6
Vent Termination Restrictions.....	6
Vent Configurations.....	7
Vent Restrictor Ring.....	7
Vent Parts.....	8
Planning Your Installation.....	9
Horizontal Installation.....	10
Corner Installations.....	12
Vertical Installation.....	12
Cathedral Ceiling Installation.....	15
Freestanding Direct Vent Kit With Coupler.....	15
Venting into a Class 'A' Chimney.....	18
Mobile Home Installation.....	18
Electrical Requirements.....	19
Replacing The Blower.....	20
Adjusting The Venturies.....	20
Fuel Conversion.....	21
Gas Line Connection and Testing.....	22
Secondary Installation.....	23
Installation of Log Set and Embers.....	23
Operating Instructions.....	25
Lighting Instructions.....	25
Turning Gas Off To Appliance.....	25
Routine Maintenance and Service.....	26
Trouble Shooting.....	27
Parts List.....	28
Parts Diagram - Chassis.....	30
Parts Diagram - Gas Tray & Door.....	31
Warranty.....	32
Installation Data Sheet.....	33

# CODES AND APPROVALS

**DIRECT VENT:** This type is identified by the suffix DV. This appliance draws all of its air for combustion from outside the dwelling, through a specially designed vent pipe system.

This appliance has been tested and approved for installations from 0 feet to 4500 feet (1372 m) above sea level.

**In the USA:** The appliance may be installed at higher altitudes. Please refer to your American Gas Association guidelines which state: the sea level rated input of Gas Designed Appliances installed at elevations above 2000 feet (610 m) is to be reduced 4% for each 1000 feet (305 m) above sea level. Refer also to local authorities or codes which have jurisdiction in your area regarding the de-rate guidelines.

**In Canada:** When the appliance is installed at elevations above 4500 feet (1372 m), the certified high altitude rating shall be reduced at the rate of 4% for each additional 1000 feet (305 m).

- This appliance has been tested by INTERTEK (**Warnock Hersey**) and found to comply with the established VENTED GAS FIREPLACE HEATER standards in CANADA and the USA as follows:

## VENTED GAS FIREPLACE HEATER (EG40 DV NG/LPG)

TESTED TO: ANSI Z21.88a-2003/CSA 2.33a-2003 VENTED GAS FIREPLACE HEATERS

CAN/CGA 2.17-M91 GAS FIRED APPLIANCES FOR HIGH ALTITUDES

CSA P.4.1-02 TESTING METHOD FOR MEASURING ANNUAL FIREPLACE EFFICIENCY

### This ENVIRO EG40 DV Fireplace:

- Has been certified for use with either natural or propane gases. (See rating label.)
- Is not for use with solid fuels.
- Is approved for bedroom or bed sitting room. (**IN CANADA:** must be installed with a listed wall thermostat. **IN USA:** see current ANSI Z223.1 for installation instructions.)
- Must be installed in accordance with local codes. If none exist, use current installation code CAN/CGA B149 in Canada or ANSI Z223.1/NFPA 54 in the USA.
- Must be properly connected to an approved venting system and not connected to a chimney flue serving a separate solid-fuel burning appliance.
- Manufactured (mobile) home installation must be in accordance with the Manufactured Home Construction and Safety Standard, UL 307B, Title 24 CFR, Part 3280 and/or The Standard for Manufactured Home Installations, ANSI A225.1/NFPA 501A. The unit must be bolted to the floor of the mobile home and must be electrically grounded to the steel chassis.
- Are approved for installation on combustible materials (i.e. Wood, carpet or linoleum).
- Is not approved for closet or recessed installations.

**IMPORTANT NOTICE (Regarding first fire up):** When the unit is turned on for the first time, it should be turned onto high without the fan on for the first 4 hours. This will cure the paint, logs, gasket material and other products used in the manufacturing process. It is advisable to open a window or door, as the unit will start to smoke and can irritate some people. After the unit has gone through the first burn turn the unit off including the pilot, let the unit get cold then remove the glass door and clean it with a good gas fireplace glass cleaner, available at your local ENVIRO dealer.

NATIONAL  
FIREPLACE  
INSTITUTE



CERTIFIED

[www.nficertified.org](http://www.nficertified.org)

We recommend that our gas hearth products be installed and serviced by professionals who are certified in the U.S. by the National Fireplace Institute® (NFI) as NFI Gas Specialists.

# SPECIFICATIONS

## WARNING:

Operation of this heater when not connected to a properly installed and maintained venting system can result in carbon monoxide (CO) poisoning and possible death.

## DIMENSIONS:

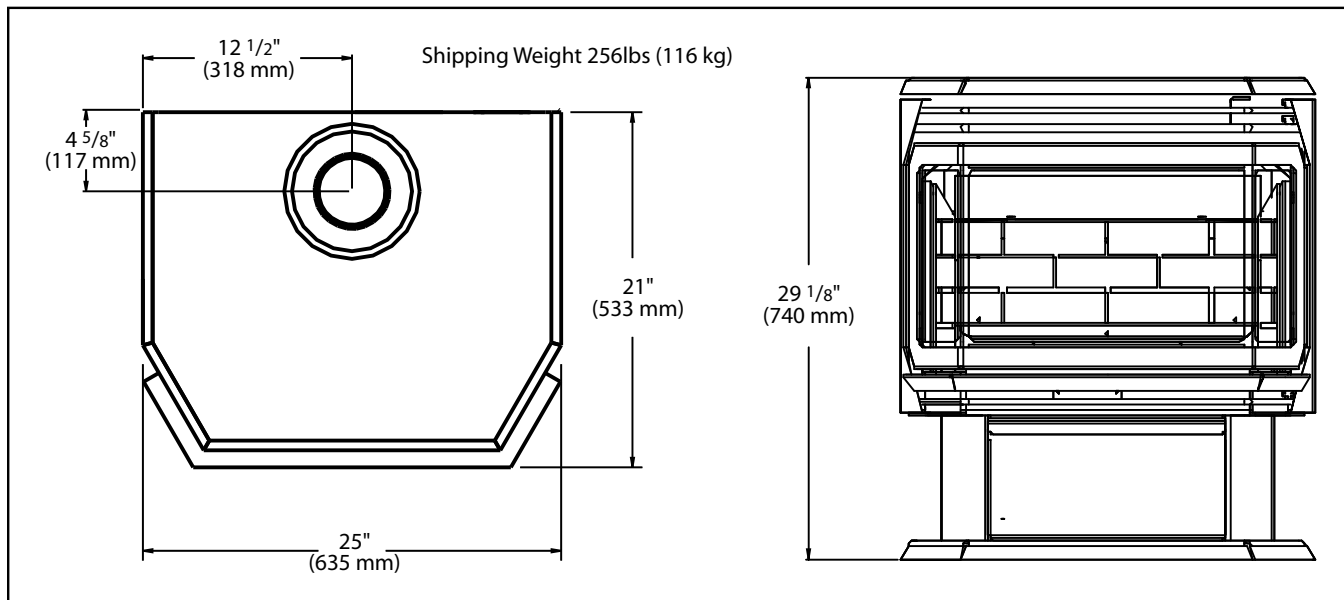

Figure 1: EG40 Exterior Dimensions.

## CLEARANCES TO COMBUSTIBLES:

A. Sidewall to unit	12 inches (30.5 cm)
B. Backwall to unit	4 inches (10.2 cm)
C. Corner to unit	2 inches (5.1 cm)
D. Combustibles to unit top	36 inches (91.4 cm)
E. Floor to unit	0 inches
F. Alcove maximum depth:	48 inches (121.9 cm)

- Locate a position where the flue system of the stove can be properly installed without damaging the integrity of the building; e.g. cutting a wall or ceiling joist.
- Check stove and flue system clearance requirements.
- Locate the stove where it can be accessed by a gas supply line.
- Locate the stove in a large and open room that is centrally located in the house. This will optimize heat circulation and comfort.
- As the stove is equipped with a convection fan, ensure that an electrical outlet is within 6 feet. (1.8 m) of the stove.
- The flow of combustion and ventilation air must not be obstructed.

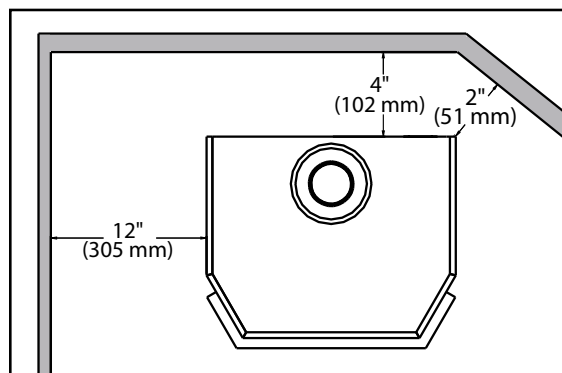

Figure 2: Clearances to combustibles.

## CLEARANCES MUST BE SUFFICIENT TO ALLOW ACCESS FOR MAINTENANCE AND SERVICE.

## PREPARATION FOR INSTALLATION:

- Remove the packaging from the appliance, and check to make sure there is no damage. If damage is found, please report it to both the carrier and your dealer as soon as possible.
- Before beginning, carefully check the glass door and the log set

# INITIAL INSTALLATION

## QUALIFIED INSTALLERS ONLY

### VENT TERMINATION RESTRICTIONS:

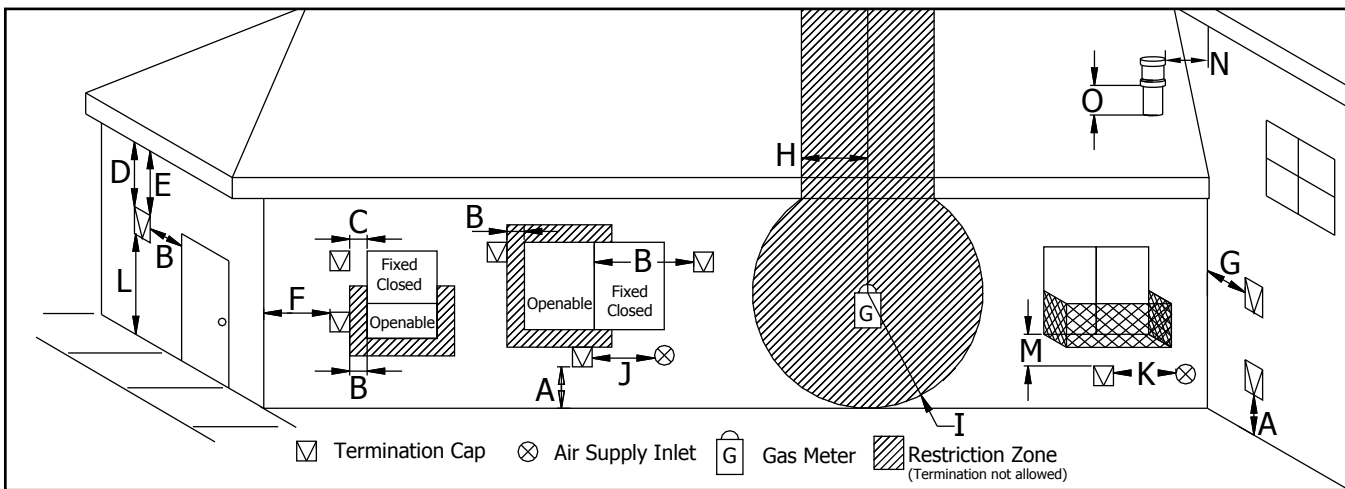

**Figure 3: Exterior Vent Termination Locations, use in conjunction with Table 1.**

**Table 1: Exterior Vent Termination Locations, use in conjunction with Figure 3.**

Letter	Canadian Installation <sup>1</sup>	US Installation <sup>2</sup>	Description
A	12 in (30 cm)		Clearance above grade, verandah, porch, deck, or balcony.
B	12 in (30 cm)	9 in (23 cm)	Clearance from window or door that may be opened.
C	12 in (30 cm)*		Clearance from permanently closed window (to prevent condensation).
D	24 in (60 cm)*		Vertical clearance to ventilated soffit located above the terminal, within a horizontal distance of 2 ft (60 cm) from center line of terminal.
E	18 in (45 cm)*		Clearance to unventilated soffit.
F	12 in (30 cm)*		Clearance to outside corner.
G	12 in (30 cm)*		Clearance to inside corner.
H	3 ft (91 cm) within a height of 15 ft (4.5 m) above the meter/regulator assembly	3 ft (91 cm) within a height of 15 ft (4.5 m) above the meter/regulator assembly*	Clearance to each side of center line extended above meter/regulator assembly.
I	3 ft (91 cm)	3 ft (91 cm)*	Radial clearance around service regulator vent outlet.
J	12 in (30 cm)	9 in (23 cm)	Clearance to non-mechanical air supply inlet to building, or the combustion air inlet to any other appliance.
K	6 ft (1.83 m)	3 ft (91 cm) above if within 10 ft (3 m) horizontally	Clearance to mechanical air supply inlet.
L	7 ft (2.13 m) <sup>t</sup>	7 ft (2.13 m) <sup>*t</sup>	Clearance above paved sidewalk or paved driveway located on public property.
M	12 in / 30 cm <sup>+</sup>	12 in / 30 cm <sup>*+</sup>	Clearance under verandah, porch, deck, or balcony.
N	12 in (30 cm)*		Clearance horizontally to any surface (such as an exterior wall) for vertical terminations.
O	12 in (30 cm)		Clearance above roof line for vertical terminations.

<sup>1</sup> In accordance with the current CSA B149, Natural Gas and Propane Installation Code.

<sup>2</sup> In accordance with the current ANSI Z223.1 NFPA 54, National Fuel Gas Code.

\* These numbers are only estimates. Clearance in accordance with installation codes and the requirements of the gas supplier.

<sup>t</sup> A vent shall not terminate directly above a side walk or paved driveway that is located between two single family dwellings and it serves both dwellings.

<sup>+</sup> Permitted only if verandah, porch, deck, or balcony is fully open on a minimum of two sides beneath the floor.

**NOTE: Venting terminals shall not be recessed into walls or siding.**

# INITIAL INSTALLATION

## QUALIFIED INSTALLERS ONLY

### VENT CONFIGURATIONS:

Figure 4 shows the range of venting options, it shows possible vent configurations if the unit is top vented, for vertical and horizontal terminations, any layout that remains within the shaded area is acceptable. Having the fewest number of elbows is ideal, as they tend to disrupt air movement. Using 45° elbows is preferable to using 90° elbows. Also, a shorter vent system will perform better than a longer one.

NOTE: The total length of the vent pipes can not exceed 33 feet (10.1 m). Any combination of rise and run can be used as long as it lays within the shaded area (a total of three (3) 90° elbows or six (6) 45° elbows can be used). In addition to what is shown, if a 90° elbow is used in the horizontal plane, 3 feet (91.4 cm) must be subtracted from the allowable horizontal run (for each 45° elbow, 1½ feet must be subtracted from the allowable horizontal run).

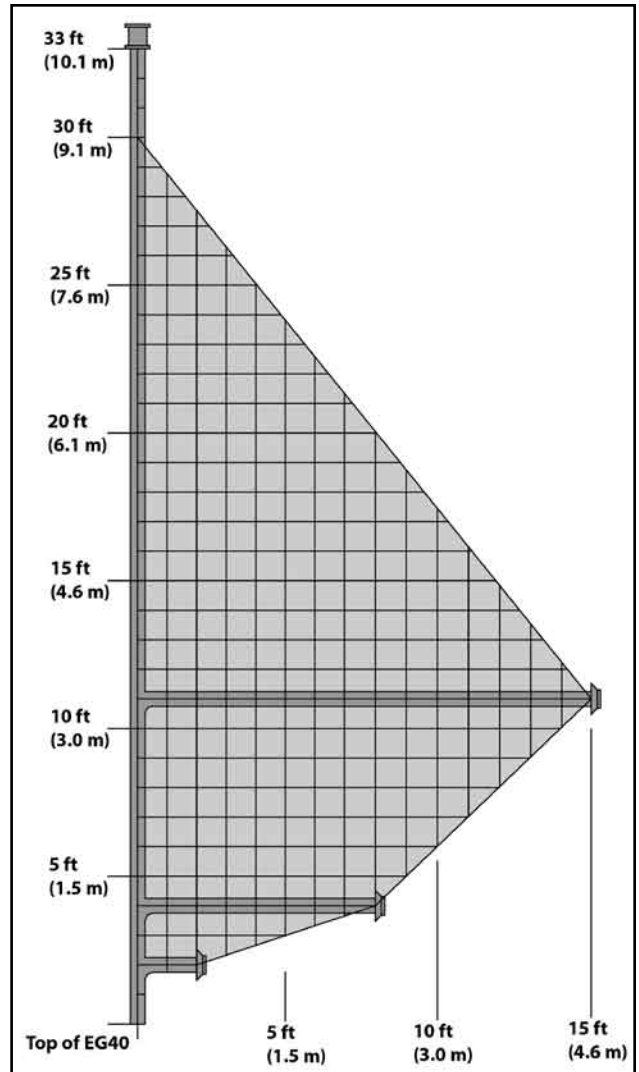

Figure 4. Possible Vent Configurations; Vertical and Horizontal Terminations.

### VENT RESTRICTOR RING:

A vent restrictor ring is supplied with each direct vent fireplace. This restrictor ring is to be installed when the vertical chimney installation is over 6 feet (1.83 m). Before the chimney is placed onto the stove, place this vent restrictor ring into the 4 inch (10.2 cm) flue pipe (as shown), once the vent restrictor ring has been installed, the vertical sections of chimney can be installed.

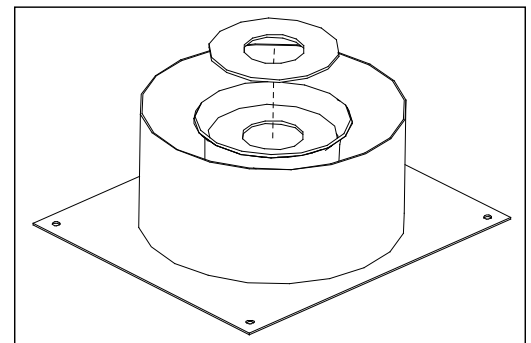

Figure 5: Vent restrictor ring.

# INITIAL INSTALLATION

## QUALIFIED INSTALLERS ONLY

### VENT PARTS:

For horizontal venting installations Sherwood Industries Ltd.'s DV Kit with Coupler (part# EC-061) can be used, refer to "Initial Installation - Freestanding Direct Vent Kit with Coupler."

**Table 2: Vent Pipe Types with Part Numbers.**

Simpson Duravent (SD), Selkirk (SEL), and Security Chimneys (SC), must state if galvanized or black wanted, PART NUMBERS:

SD	SEL	SC	Description	SD	SEL	SC	Description
908	4DT-6	SV4L6	6" pipe length	911	<del>          </del>	<del>          </del>	11" to 14 5/8" pipe, adjustable
907	4DT-9	<del>          </del>	9" pipe length	<del>          </del>	4DT-AJ	<del>          </del>	4" to 10" pipe , adjustable
906	4DT-12	SV4L12	12" pipe length	<del>          </del>	<del>          </del>	SV4LA12	1 1/2" to 12" pipe , adjustable
904	4DT-24	SV4L24	24" pipe length	943	4DT-AF6	<del>          </del>	Flashing, 0/12 to 6/12 roof pitch
903	4DT-36	SV4L36	36" pipe length	943S	4DT-AF12	<del>          </del>	Flashing, 7/12 to 12/12 roof pitch
902	4DT-48	SV4L48	48" pipe length	<del>          </del>	<del>          </del>	SV4FA	Flashing, 1/12 to 7/12 roof pitch
945	4DT-EL45	SV4EBR45	45° elbow, black	<del>          </del>	<del>          </del>	SV4FB	Flashing, 8/12 to 12/12 roof pitch
990	4DT-EL90	SV4EBR90	90° elbow, black	943F	<del>          </del>	SV4F	Flat flashing
950	4DT-VS	SV4VS	Vinyl siding standoff/sheild	980	4DT-VC	SV4CGV	Vertical termination
942	4DT-WT	SV4RSN	Wall thimble	991	4DT-HVC	<del>          </del>	High wind vertical termination
941	4DT-CSS	SV4CSB	Cathedral Support Box	984	4DT-HC	SV4CHC	Horizontal square termination
981	4DT-ST36	SV4STC36	36" Snorkel Termination	985	4DT-HHC	<del>          </del>	High wind horizontal termination
953	4DT-SC	SV4FC	Storm collar	978	4DT-VKC	SV0FAK	Vertical termination kit
963	4DT-FS	SV4BF	Fire stop	970	4DT-HKA	SV0SHK	Horizontal termination kit SD: Basic Kit, SEL: Kit A, SC: Standard Kit
988	4DT-WS/B	SV4BM	Wall strap/support/band				
				971	4DT-HKB	SV0SHK2	Horizontal termination kit SD: Kit A, SEL: Kit B, SC: Kit

This fireplace have been tested and certified for use with SIMPSON DURAVENT TYPE GS PIPE FOR GAS STOVES. SELKIRK DIRECT-TEMP SYSTEM SECURITY CHIMNEY'S "SECURE VENT DIRECT VENT SYSTEM" and SELKIRK "DIRECT TEMP VENT SYSTEM" kits are available for horizontal venting. When using Simpson Duravent, it is recommended that, before installation, a bead of RTV High Temperature Silicone should be applied to each outer vent joint, and Mil-Pac to each inner joint. When planning an installation, it will be necessary to select the proper length of vent pipe for the particular requirements.

**A MINIMUM VERTICAL LENGTH OF 24" (61 cm) TO THE FIRST 90° ELBOW IS REQUIRED.** WITH THIS MINIMUM VERTICAL RISE, HORIZONTAL RUNS OF FROM 1 FOOT (30.5 cm) to 3 FEET (91.5 cm) ARE PERMITTED TO REACH THE OUTSIDE VENT TERMINATION.

BEFORE BEGINNING THE INSTALLATION TAKE CARE TO ENSURE AN APPROPRIATE OUTSIDE LOCATION FOR THE VENT TERMINATION CAN BE ACCOMMODATED. **FOLLOW THE VENT LENGTH DIAGRAM PRECISELY.**

**VENTING TERMINALS CANNOT BE RECESSED INTO A WALL OR SIDING.**



# INITIAL INSTALLATION

## QUALIFIED INSTALLERS ONLY

### PLANNING YOUR INSTALLATION:

When planning your installation, it will be necessary to select the proper length of vent pipe for your particular requirements. It is important to note when passing through a wall, the maximum allowable wall thickness is 10 inches (25.4 cm), 1½ inches (3.8 cm) clearance to combustibles must be maintained. Select the amount of vertical rise desired for "vertical-to-horizontal" type installations. To determine the length of vent pipe required for vertical installations, measure the distance from the appliance flue outlet to the ceiling, the ceiling thickness, the vertical rise through the attic or second story, and allow for sufficient vent height above the roof line. For two story applications, a fire stop is required at each floor level. If an offset is needed in the attic, additional pipe and elbows will be required. To connect the venting system to the appliance flue outlet, a twist-lock adapter is built into the appliance at the factory. Refer to 'Vent Configuration and Restrictor Settings' for venting parameters.

Your total vent pipe length must be within the shaded area of Figure 4. If a 90° elbow is used in the horizontal plane, 36" (91.4 cm) must be subtracted from the allowable horizontal run.

There are three (3) basic types of Direct Vent System installations. The two (2) types of installations are:

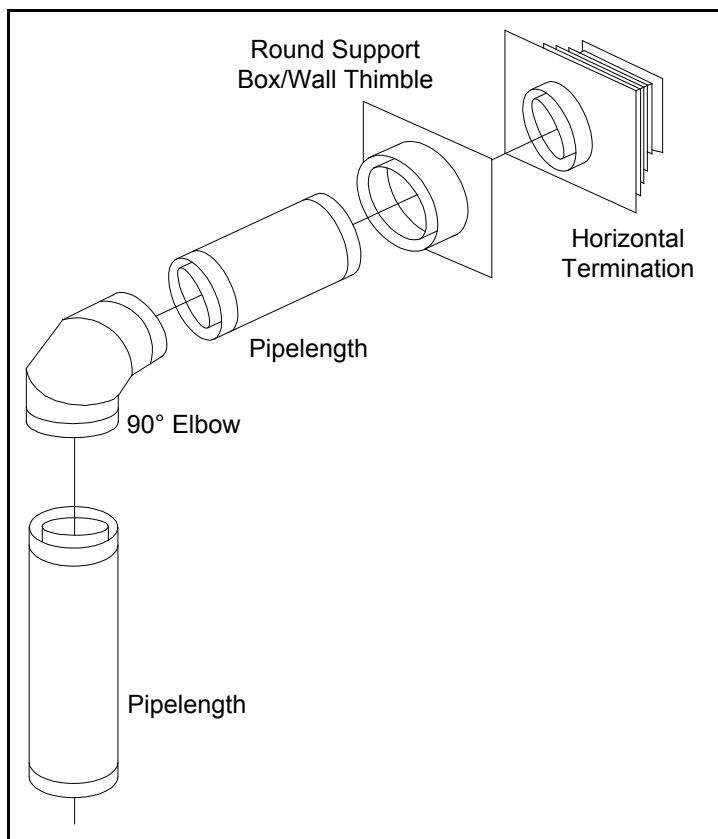

Figure 6: Common Horizontal Installation.

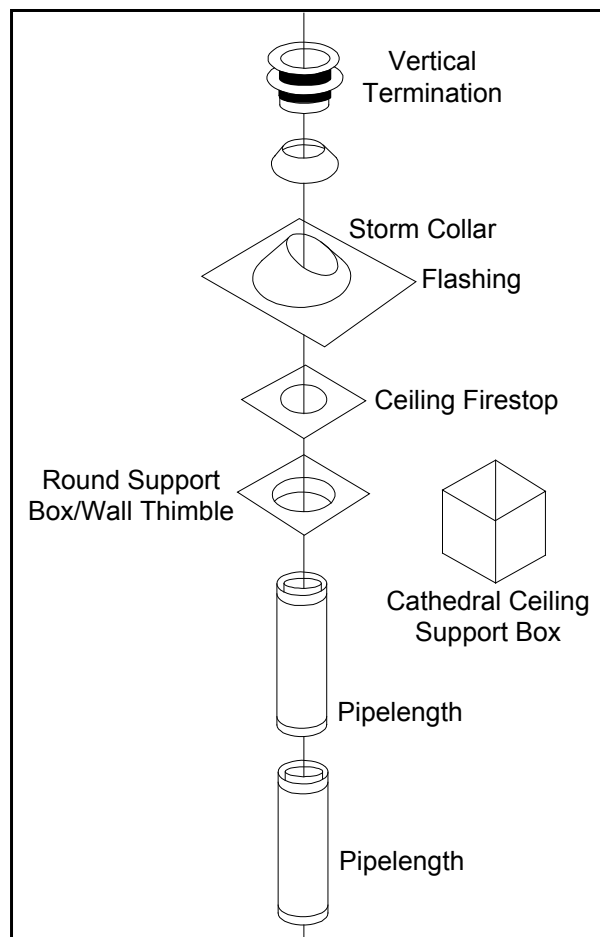

Figure 7: Common Vertical Installation.

# INITIAL INSTALLATION

## QUALIFIED INSTALLERS ONLY

### HORIZONTAL INSTALLATION:

**STEP 1.** Set the appliance in the desired location. Check to determine if wall studs or roof rafters are in the way when the venting system is attached. If this is the case, you may want to adjust the location of the appliance.

**STEP 2.** Direct vent pipe and fittings are designed with special twist-lock connections. Assemble the desired combination of black pipe and elbows to the appliance adapter with pipe seams oriented towards the wall or floor, as much out of view as possible.

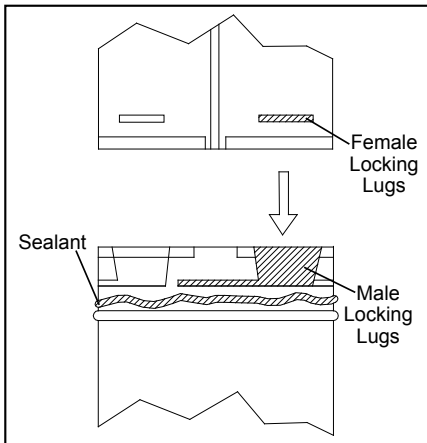

**Figure 8: Twist-Lock Connection**

Place a bead of Mil-Pac on the outer edge of the inner exhaust pipe (non-flared end). Place a bead of high temperature silicone on the male edge of the outer pipe. Push the pipe sections completely together, then twist-lock one section clockwise approximately  $\frac{1}{4}$  turn, until the two sections are fully locked. The female locking lugs will not be visible from the outside, on black pipe. They may be located by examining the inside of the female ends as shown in Figure 8.

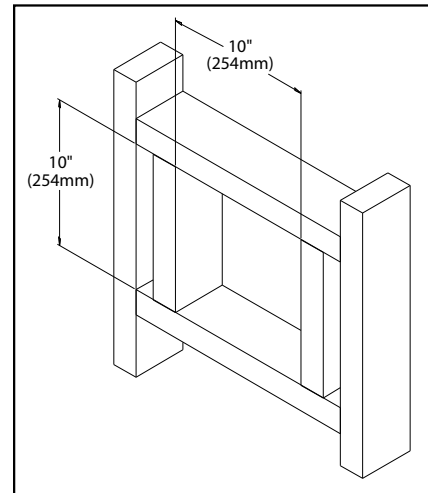

**Figure 9: Wall Framing Hole for Horizontal Installation.**

### Notes:

**(1)** Twist-lock procedure: four indentations, located on the female end of the pipes and fittings, are designed to slide straight onto the male ends of adjacent pipes and fittings, by orienting the four pipe indentations so they match and slide into the four entry slots on the male end.

**(2)** Horizontal runs of vent pipe must be supported every three feet. Wall straps are available for this purpose, also when running horizontal pipe minimum clearances to combustibles must be maintained; **2 inches (5.1 cm) at top, 1½ inches (3.8 cm) at sides, 1½ inches (3.8 cm) at bottom.**

**STEP 3.** With the pipe attached to the stove in the correct location, mark the wall for a 10" (25.4 cm) x 10" (25.4 cm) square hole (refer to Figure 9). The center of the square hole should match the center line of the horizontal pipe. Cut and frame the 10" (25.4 cm) x 10" (25.4 cm) hole in the exterior wall where the vent will be terminated. Refer to Figure 8. If the wall being penetrated is constructed of non-combustible material i.e. masonry or concrete, a 7 inches (17.8 cm) hole is acceptable.

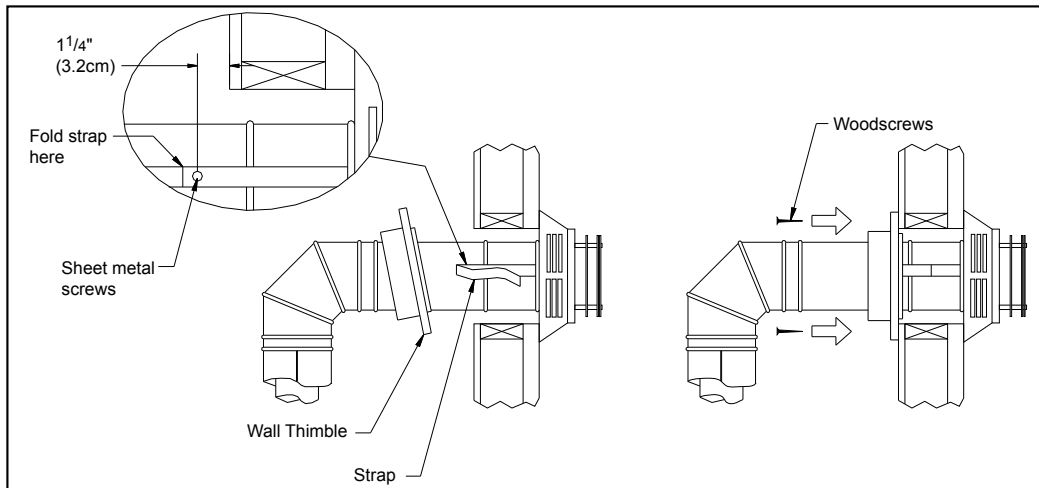

**Figure 10: Installing Decorative Wall Thimble.**

# INITIAL INSTALLATION

## QUALIFIED INSTALLERS ONLY

**STEP 4.** Position the horizontal vent termination in the center of the 10" (25.4 cm) x 10" (25.4 cm) hole, and attach to the exterior wall with the four screws provided. Before attaching the vent termination to the exterior wall, run a bead of non-hardening mastic around the edges, so as to make a seal between the termination and the wall. The arrow on the vent termination should be pointing up, insure that the proper clearances to combustible materials are maintained.

**STEP 5.** Before connecting the horizontal run of the vent pipe to the vent termination, slide the black decorative wall thimble cover over the vent pipe.

**STEP 6.** Slide the appliance and vent assembly towards the wall, carefully inserting the vent pipe into the cap assembly. It is important that the vent pipe extend into the vent cap a sufficient distance with a minimum of 1¼" (3.2 cm) overlap. Secure the connection between the vent cap pipe and the vent cap by attaching the two sheet metal straps extending from the vent cap assembly into the outer wall of the vent pipe. Use the two sheet metal screws provided to connect the straps to the vent pipe. Bend any remaining portion of the sheet metal straps back towards the vent cap, so the decorative wall thimble will conceal it (see left image in Figure 10).

**STEP 7.** Slide the decorative wall thimble up to the wall surface and attach with the screws provided. Apply decorative brass or chrome trim if desired (see right image in Figure 10).

### NOTES:

- (1) The four wood screws provided should be replaced with the appropriate fasteners for stucco, brick, concrete, or other types of siding.
- (2) For buildings with vinyl siding, a vinyl siding standoff, should be installed between the vent cap and the exterior wall (see Figure 11). Attach the vinyl siding standoff to the horizontal termination. The vinyl siding standoff prevents excessive heat from possibly melting the vinyl siding material. Note that the horizontal vent termination bolts onto the flat portion of the vinyl siding standoff (shaded area in Figure 11), so that an air space will exist between the wall and the vent termination.

### NOTES:

- (1) The horizontal run of vent pipe must be level and **should have a ¼ inch rise for every one foot of run towards the termination.** Never allow the vent to run downward. This could cause high temperature and may present the possibility of a fire.
- (2) The location of the horizontal vent termination on the exterior wall must not be easily blocked or obstructed. Refer to "Initial Installation - Vent Termination Restrictions" section.
- (3) When installing a vent pipe in a chase the minimum clearance to combustibles is 2" (5 cm).

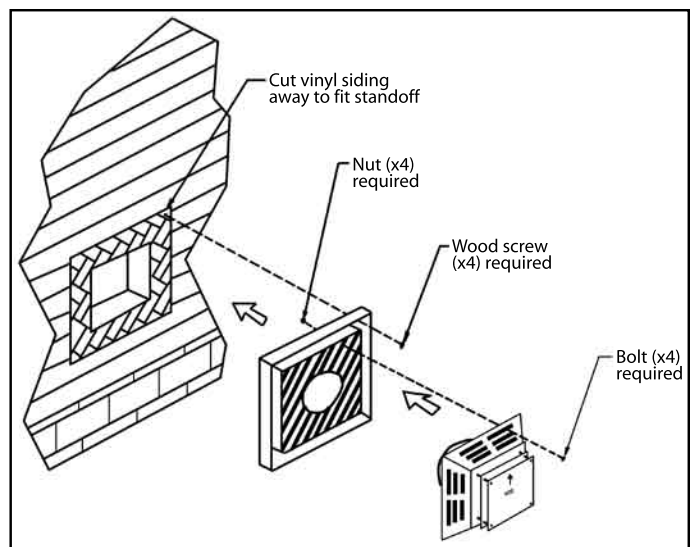

Figure 11: Installing Vent Cap with Vinyl Siding Stand-Off.

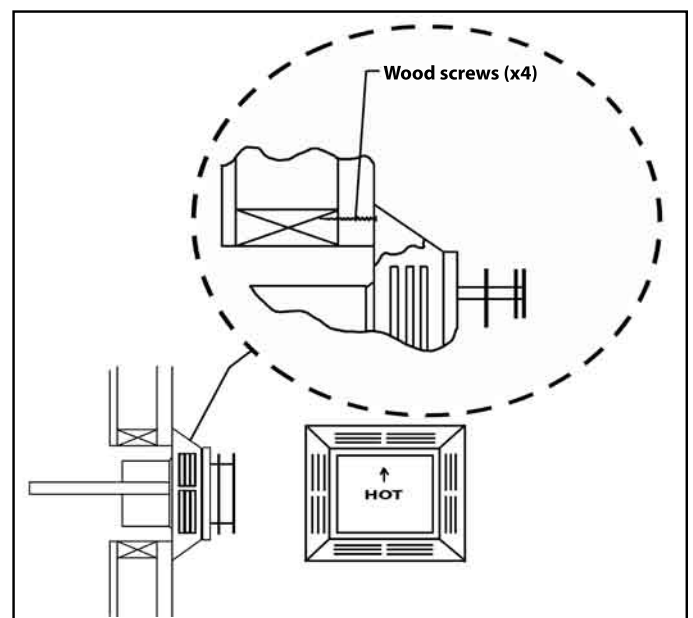

Figure 12: Installing Horizontal Vent Termination.

# INITIAL INSTALLATION

## QUALIFIED INSTALLERS ONLY

### CORNER INSTALLATIONS:

Do not interfere with the structural integrity of the walls.

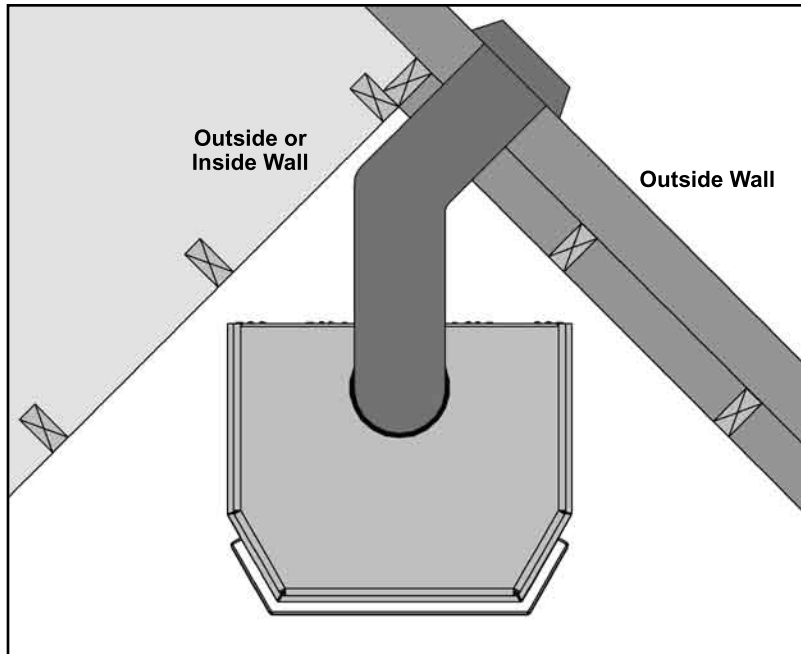

Figure 13: Corner installation top vented.

### VERTICAL INSTALLATION:

**STEP 1.** Check the instructions for required clearances (air spaces) to combustibles when passing through ceilings, walls, roofs, enclosures, attic rafters, or other nearby combustible surfaces. Do not pack air spaces with insulation.

**STEP 2.** Set the gas appliance in the desired location. Drop a plumb bob down from the ceiling to the position of the appliance flue exit, and mark the location where the vent will penetrate the ceiling. Drill a small hole at this point. Next, drop a plumb bob from the roof to the hole previously drilled in the ceiling, mark the spot where the vent will penetrate the roof. Determine if ceiling joists, roof rafters, or other framing will obstruct the venting system. You may wish to relocate the appliance, or to offset, to avoid cutting load bearing members.

**STEP 3.** To install the Round Support Box/Wall Thimble in a flat ceiling, cut a 10 inch (25.4 cm) square hole in the ceiling, centered in the hole drilled in Step 2. Frame the hole as shown in Figure 14.

**STEP 4.** Assemble the desired lengths of black pipe and elbows necessary to reach from the appliance adapter up through the Round Support Box. Insure that all pipe and elbow connections are in their fully twist-locked position.

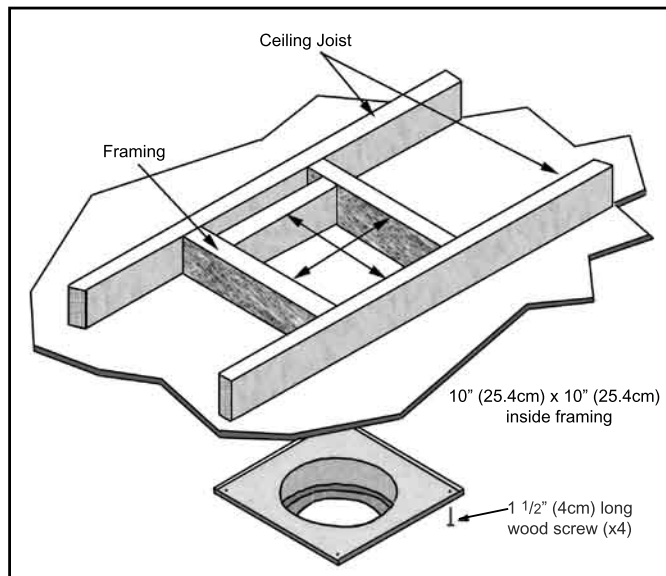

Figure 14: Wall Framing for 10" (25.4 cm) x 10" (25.4 cm) Hole for Vertical Installation.

# INITIAL INSTALLATION

## QUALIFIED INSTALLERS ONLY

**STEP 5.** Cut hole in the roof centered on the small hole placed in the roof from Step 2. The hole should be of sufficient size to meet minimum requirements for Clearance to Combustibles, as specified. Continue to assemble lengths of pipe and elbows necessary to reach from the ceiling support box up through the roof line. Galvanized pipe and elbows may be utilized in the attic, as well as above the roof line. The galvanized finish is desirable above the roof line, due to the higher corrosion resistance.

**STEP 6.** Once the pipe sections have been joined, and run up through the hole in the roof, slip an elbow strap over the exposed sections, bend the support straps outwards, and push the elbow strap down to the roof level, as shown in Figure 15. Tighten the clamp around the pipe section. Use a level to make sure the pipe is truly vertical. With roofing nails, secure the support straps to the roof. Seal the nail holes with non-hardening mastic. Trim the excess length of the support straps that extend out beyond the edge of the flashing.

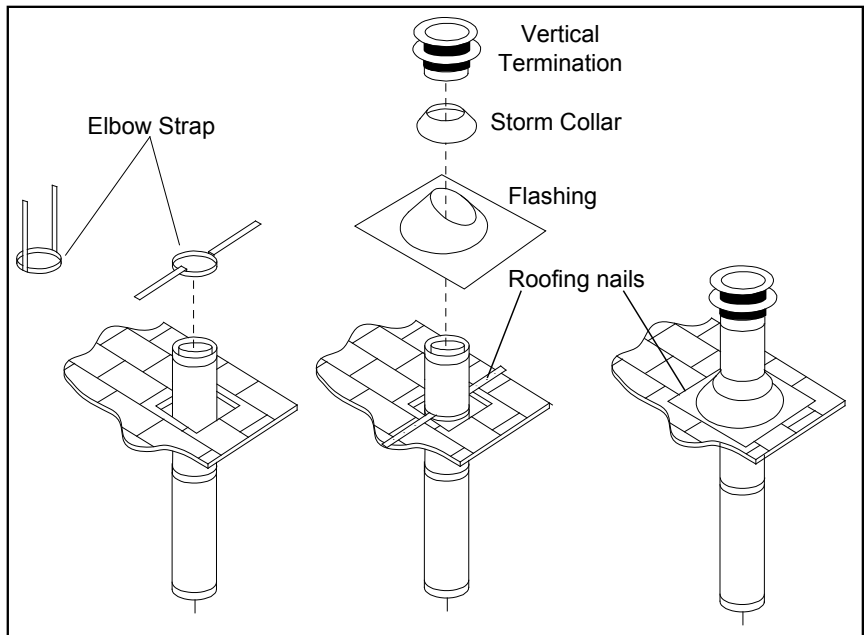

**Figure 15: Vertical Vent Termination Installation.**

**STEP 7.** Slip the flashing over the pipe section protruding through the roof. Secure the base of the flashing to the roof with roofing nails. Use a non-hardening sealant between the uphill edge of the flashing and the roof. Insure the roofing material overlaps the top edge of the flashing as shown in Figure 15. Verify that you have at least the minimum clearance to combustibles at the roof line.

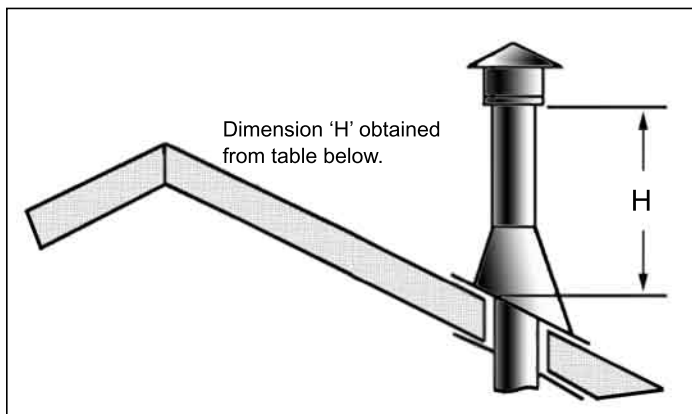

**Figure 16: Height of Vertical Termination; Reference Table 3.**

**Table 3: Minimum 'H' for Figure 16**

Roof Pitch	Minimum Height	
	Feet	Meters
Flat to 7/8	1	0.3
Over 7/12 to 8/12	1.5	0.46
Over 8/12 to 9/12	2	0.61
Over 9/12 to 10/12	2.5	0.76
Over 10/12 to 11/12	3.25	0.99
Over 11/12 to 12/12	4	1.22
Over 12/12 to 14/12	5	1.52
Over 14/12 to 16/12	6	1.83
Over 16/12 to 18/12	7	2.13
Over 18/12 to 20/12	7.5	2.29
Over 20/12 to 21/12	8	2.44

# INITIAL INSTALLATION

## QUALIFIED INSTALLERS ONLY

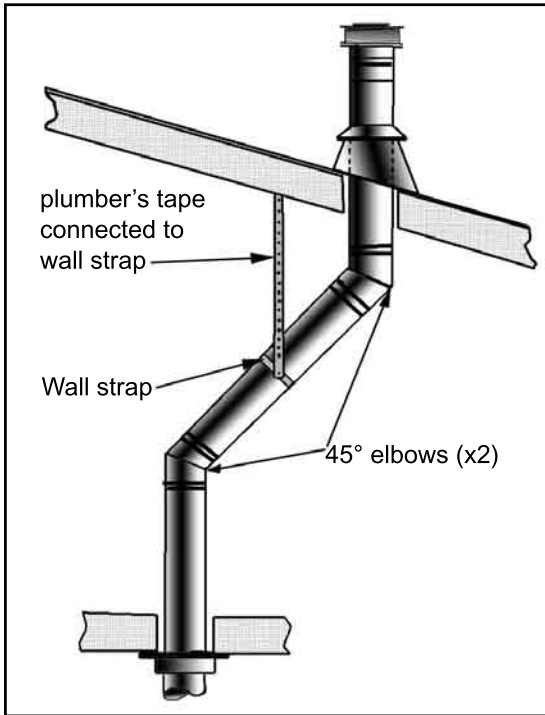

Figure 17: Use of Wall Straps.

**STEP 8.** Continue to add pipe sections until the height of the vent cap meets the minimum code requirements. Refer to Figure 16 and Table 3. Note that for steep roof pitches, the vent height must be increased. In high wind conditions, nearby trees, adjoining roof lines, steep pitched roofs, and other similar factors can result in poor draft, or down drafting. In these cases, increasing the vent height may solve the problem.

**STEP 9.** Slip the storm collar over the pipe, and push it down to the top of the roof flashing as shown in Figure 15. Use the non-hardening sealant around the joint between the pipe and the storm collar.

**STEP 10.** Twist-lock the vent cap.

### NOTES:

(1) If an offset is necessary in the attic to avoid obstructions, it is important to support the vent pipe every 3 feet (91 cm), to avoid excessive stress on the elbows, and possible separation. Wall straps are available for this purpose (see Figure 17).

(2) When ever possible, use 45° degree elbows instead of 90° degree elbows. The 45° degree elbow offers less restriction to the flow of flue gases and intake air.

### NOTES:

(1) For multi story installations. A ceiling firestop is required at the second floor, and any subsequent floors (see Figure 14). The opening should be framed to 10" (25.4 cm) x 10" (25.4 cm) inside dimensions, in the same manner as shown in Figure 14.

(2) Any occupied areas above the first floor, including closets and storage spaces, which the vertical vent passes through, must be enclosed. The enclosure may be framed and sheetrocked with standard building materials. However consult the appliance manufactures installation instructions for the minimum allowable clearance between the outside of the vent pipe, and the combustible surfaces of the enclosure. Do not fill any required air spaces with insulation.

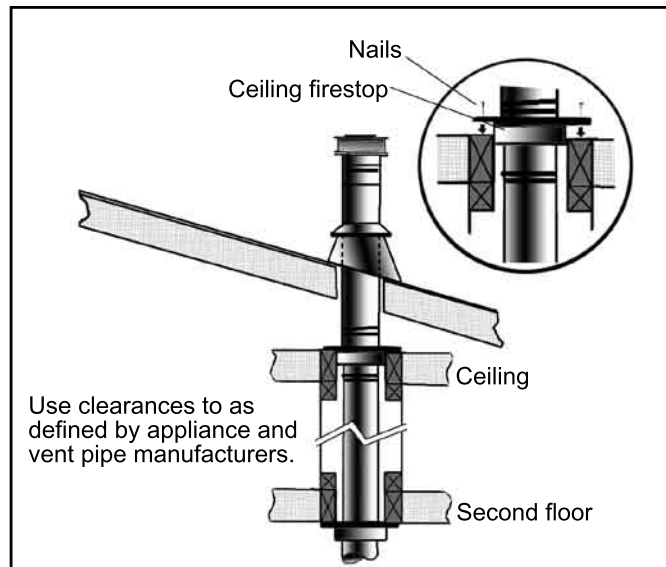

Figure 18: Multi-Story Vent Pipe Installation.

# INITIAL INSTALLATION

## QUALIFIED INSTALLERS ONLY

### CATHEDRAL CEILING INSTALLATION:

**STEP 1.** Follow installation steps 1 & 2 under 'Vertical Installation'.

**STEP 2.** Using the plumb bob, mark the center line of the venting system on the ceiling and drill a small hole through the ceiling and roof at this point. From the roof, locate the drill hole and mark the outline of the "Cathedral Ceiling Support Box".

**STEP 3.** Remove shingles or other roof coverings as necessary to cut the rectangular hole for the "Support Box". Cut the hole 1/8" larger than the "Support Box" outline.

**STEP 4.** Lower the "Support Box" through the hole in the roof until the bottom of the "Support Box" protrudes at least 2 inches (5 cm) below the ceiling. Align the "Support Box" both vertically and horizontally with a level as shown in Figure 19. Temporarily tack the "Support Box" in the place through the inside walls and into the roof sheathing.

**STEP 5.** Using tin snips, cut the "Support Box" from the top corners down to the roof line, and fold the resulting flaps over the roof sheathing (Figure 20). Before nailing it in to the roof, run a bead of non-hardening mastic around the top edges of the "Support Box", to make a seal between the box and the roof. Clean out any combustible material from the inside of the "Support Box".

**STEP 6.** Complete the cathedral ceiling installation by following the same procedures outlined in Steps 4 through 9 for "Vertical Installation".

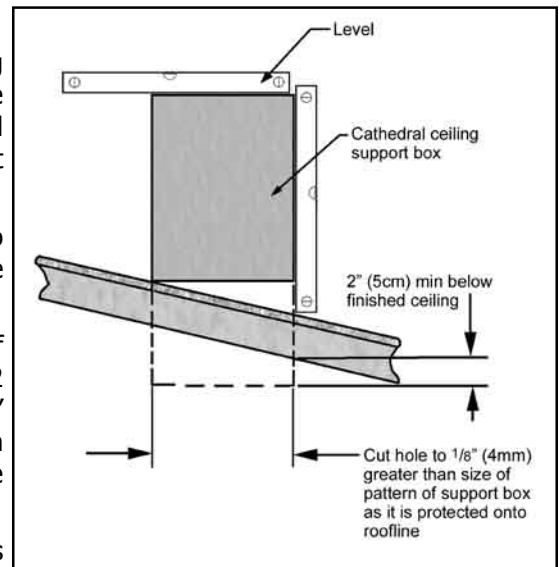

**Figure 19: Cathedral Ceiling Support Box Leveling.**

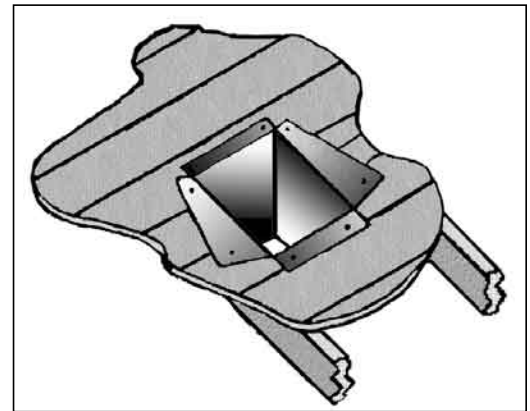

**Figure 20: Cathedral Ceiling Support Box Installation.**

### FREESTANDING DIRECT VENT KIT WITH COUPLER:

#### KIT COMPONENTS:

Quantity	Description	Quantity	Description
1	Horizontal direct vent termination cap	1	Ø6 <sup>5</sup> / <sub>8</sub> " (17 cm) 90° elbow
2	Flue collar adapters (only one used)	4	Wire spacers
4	T-20 Torx screws	3	Decorative rings
1	Wall thimble	1	4 oz tube RTV silicone
1	Inside finish trim collar	20	9/16" tech screws
1	5' (190 cm) length of Ø4" (10 cm) double walled flex pipe	8	1 1/2" wood screws
2	24" (61 cm) section of Ø6 <sup>5</sup> / <sub>8</sub> " (17 cm) straight pipe	1	Vinyl siding deflector

Please ensure that all components are supplied with this kit. If components are missing or have been damaged, contact your dealer, distributor, or courier company. Do not attempt the installation if components are missing or damaged.

# INITIAL INSTALLATION

## QUALIFIED INSTALLERS ONLY

### INSTALLATION INSTRUCTIONS:

1. Decide on a location for the unit that will meet any or all local code requirements. Refer "Planning Your Installation" and "Clearances to Combustibles".
2. Set the appliance in the desired location. Determine if any wall studs, electrical wiring, or plumbing pipes are in the way of the venting system as it passes through the wall. If obstructions are found in the wall it may be necessary to adjust the location of the appliance.
3. Set the appliance in the desired location. Temporarily place a 24" (61 cm) section with the non-crimped end on the unit
4. Install the 90° elbow onto the vertical pipe on the stove pointing in the direction that the vent will exit the structure.
5. Project a level line from the center point of the elbow. Using this center point, scribe a 10" (25.4 cm) hole or square on the wall. Cut the hole out on both the interior and exterior wall surface.
6. Frame the hole as shown in Figure 9.
7. Install the wall thimble and secure the thimble to the inner wall surface.
8. With the appliance still in place install the 24" (61 cm) horizontal section on the elbow and let this section of pipe protrude through the exterior surface. Mark the pipe so that when it is cut it will be flush with the exterior wall.
9. Dismantle the outer pipe sections.
10. Remove the 4" (10 cm) flue collar from the unit and remove any loose sealant. Install the new Ø 4" (10 cm) by 5" (12.5 cm) flue collar provided in this kit.
11. Stretch the liner out. Attach the flexible liner to the vent termination cap by placing a small bead of high temperature silicone on the vent termination and slide the flex liner onto the vent terminal and secure with three (3) sheet metal screws evenly spaced.
12. Dress the flex liner through the wall thimble and attach the vent terminal to the outside of the house using four (4) wood screws provided. The use of non-hardening mastic should be used around the vent to ensure a watertight seal.
13. Install two (2) wire spacer around the flex pipe. Slide the horizontal section of pipe over the flexible liner. Ensure the wire spacers are positioned at either end of the pipe (refer to Figure 21 and 22).

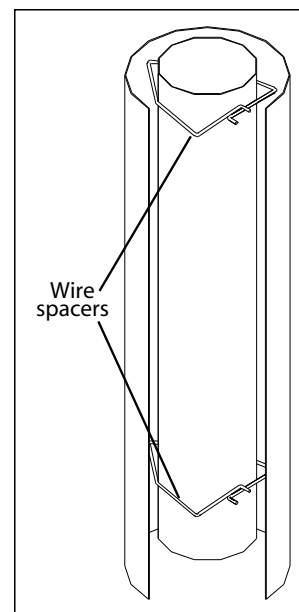

**Figure 21: Cut away of spacers on Flex Pipe.**



**Figure 22: Top view of spacers on Flex Pipe.**

14. Install the horizontal section of pipe through the wall thimble, ensure that this portion of pipe slides onto the vent termination cap.
15. Slide the inside finished collar over the horizontal section of pipe and secure to wall using the screw provided.
16. Slide the 90° elbow over the flex pipe. **Do not slip the outer sections of pipe together, you will require some movement in these pipe section in order to secure the flex pipe to the flue outlet on the appliance.**
17. Stretch the flex liner to a length long enough to ensure the flex liner can be easily connected to the flue outlet of the appliance.
18. Install the remaining wire spacers over the flexible liner and install the vertical section of pipe. Ensure the wire spacers are positioned at either end of the pipe (refer to Figure 21 and 22).



# INITIAL INSTALLATION

## QUALIFIED INSTALLERS ONLY

19. Place a bead of high temperature silicone on the flue pipe and slide the flex liner over the collar, secure the flex liner with three (3) sheet metal screws evenly spaced.
20. Align all straight sections of pipe, slipping all joints together and installing with three (3) sheet metal screws evenly spaced.
21. Install the brass decorative rings around each joint making sure this decorative ring covers the sheet metal screws that secure each section of pipe together and secure to vent pipe in the slotted tab on the backside of the pipe so that the fastener would not be seen.
22. Secure the horizontal section of pipe to the inside finished collar by installing a screw in the tab on the inside finished collar. This will prevent the pipe from being disconnected at the vent terminal.
23. Light the appliance and ensure proper operation.

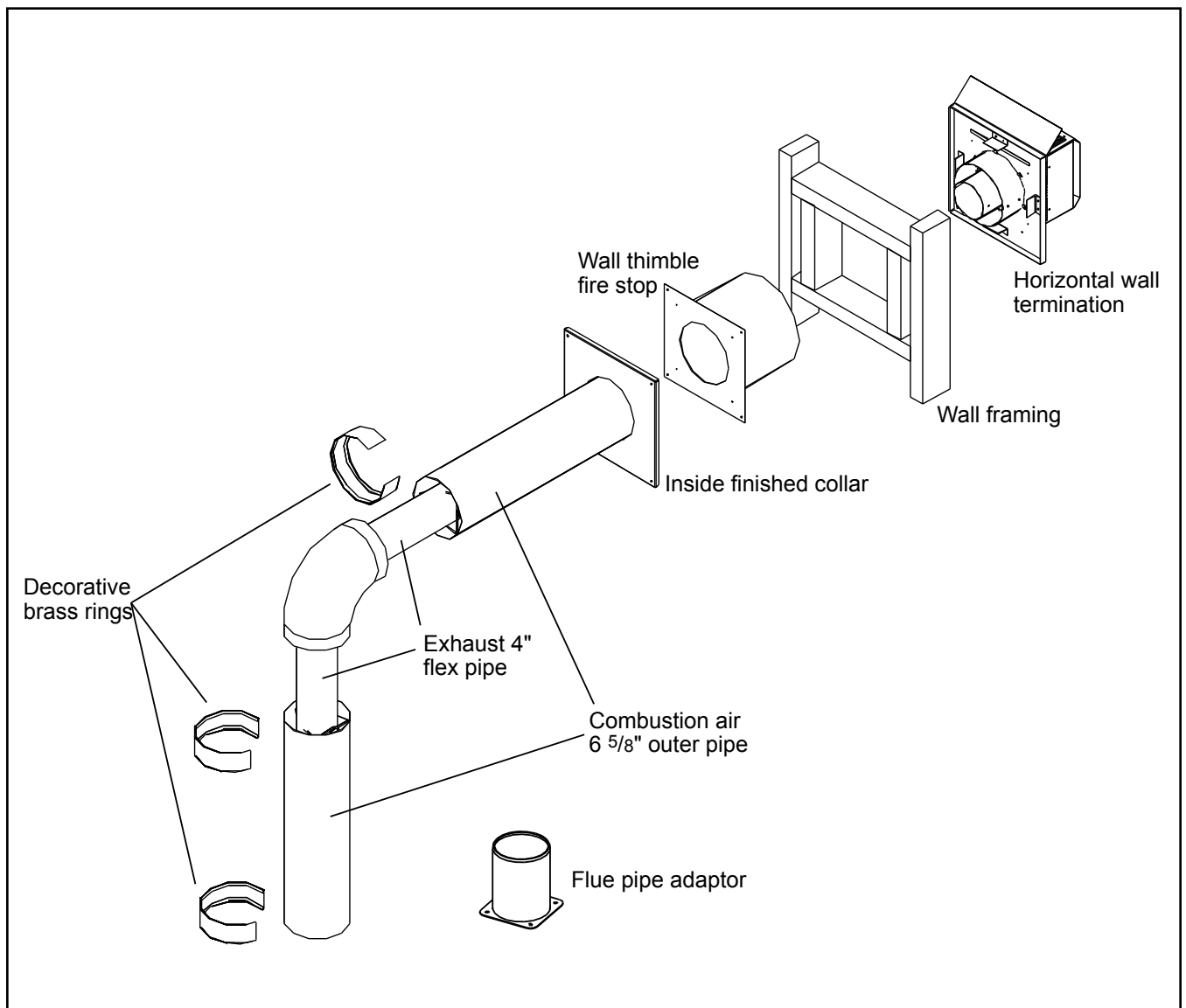

Figure 23: Assembly of Venting Kit.

# INITIAL INSTALLATION

## QUALIFIED INSTALLERS ONLY

### VENTING INTO A CLASS 'A' CHIMNEY:

This model is also certified and tested to vent into CLASS 'A' wood stove chimneys.

Place the freestanding direct vent appliance in the desired location.

Use a conversion kit from Simpson Duravent (931, 932, or 933), or Security Chimney (SV4CCK1, SV4CCK2, or SV4CCK1). Which kit is used will depend on the inner diameter of the CLASS 'A' chimney that this appliance is to be vented into.

Place a bead of high temperature silicone or Mil-Pac at each connection to ensure a tight seal.

NOTE: An approved 4" (10 cm) diameter flex liner must be used in the application.

NOTE: Use Simpson Dura Vent from the top of the appliance until this vent reaches the CLASS 'A' chimney. Install the retro adapter to the top section of GS direct vent pipe and install the flex liner to the retro adapter.

Fully line the CLASS 'A' chimney with a minimum 4" (10 cm) flex liner to the top of the CLASS 'A' chimney.

Place a bead of high temperature silicone to the Simpson Cap adapter and securely attach the flex liner to the adapter.

Secure the cap adapter to the CLASS 'A' chimney ensuring an airtight seal.

Install the vertical termination cap.

Light the unit and ensure proper operation.

THE USE OF ANY EXISTING CHIMNEY AS AN AIR INTAKE IS NOT COVERED UNDER THE ANSI Z21.88-2002 CSA 2.33a-2002 TEST METHODS AND THE RESULTING ITS/WH PRODUCT CERTIFICATION. THE CODE AUTHORITY HAVING JURISDICTION MUST BE CONSULTED PRIOR TO PROCEEDING WITH THIS INSTALLATION METHOD.

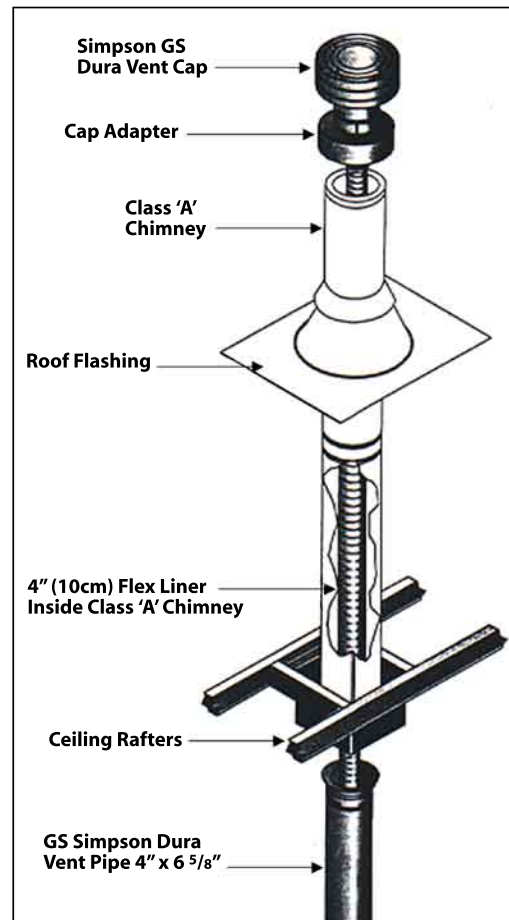

Figure 24: Assembly of Venting into a Class 'A' Chimney.

### MOBILE HOME INSTALLATION:

- When the unit is installed in a Mobile Home it must be grounded to the steel chassis or connected to a grounding rod.
- In a Mobile Home installation the unit must be bolted securely to the floor using the holes provided.
- Manufactured (mobile) home installation must be in accordance with the Manufactured Home Construction and Safety Standard, UL 307B, Title 24 CFR, Part 3280 and/or The Standard for Manufactured Home Installations, ANSI A225.1/NFPA 501A

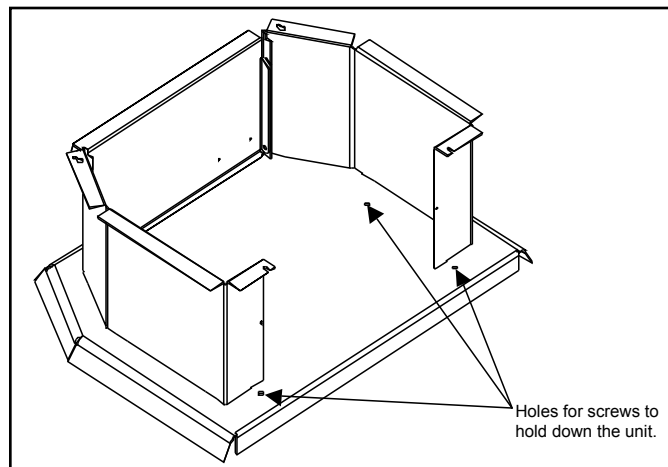

Figure 25: Screw the pedestal down for mobile homes.

# INITIAL INSTALLATION

## QUALIFIED INSTALLERS ONLY

### ELECTRICAL REQUIREMENTS:

The **ENVIRO** EG40 will operate without electrical power. This model has a millivolt gas control, which uses the pilot flame to generate enough electricity to operate the main burners. The appliance is equipped with a blower and must be electrically connected and grounded in accordance with local codes or in the absence of local codes, with the current CSA C22.1 CANADIAN ELECTRICAL CODE Part 1, SAFETY STANDARDS FOR ELECTRICAL INSTALLATIONS, OR THE NATIONAL ELECTRICAL CODE ANSI / NFPA 70 in the U.S.

**WARNING:** Electrical grounding instructions. This appliance is equipped with a three-prong (grounding) plug for your protection against shock hazard, and must be plugged directly into a properly grounded three-prong outlet.

**DO NOT** cut or remove the grounding prong from this plug.

**CAUTION:** Label all wires prior to disconnection when servicing controls. Wiring errors can cause improper and dangerous operation. Verify proper operation after servicing.

NOTE:

- Operation of the fan increases the efficiency and the heat output of the appliance.
- The thermostat connects to the two purple wires in the harness
- Control panel light uses a 7 Watt max. bulb
- **If the unit is installed in a Mobile Home it must be connected to a grounding rod.**
- **If the unit is installed in a Mobile Home it must be bolted securely to the floor.**

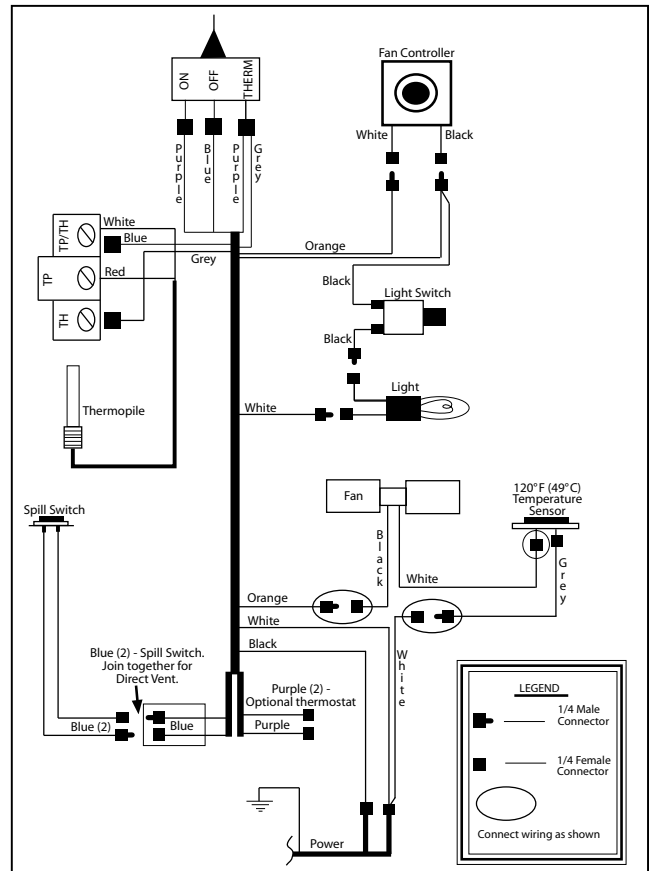

Figure 26: EG40 DV Wiring Diagram.

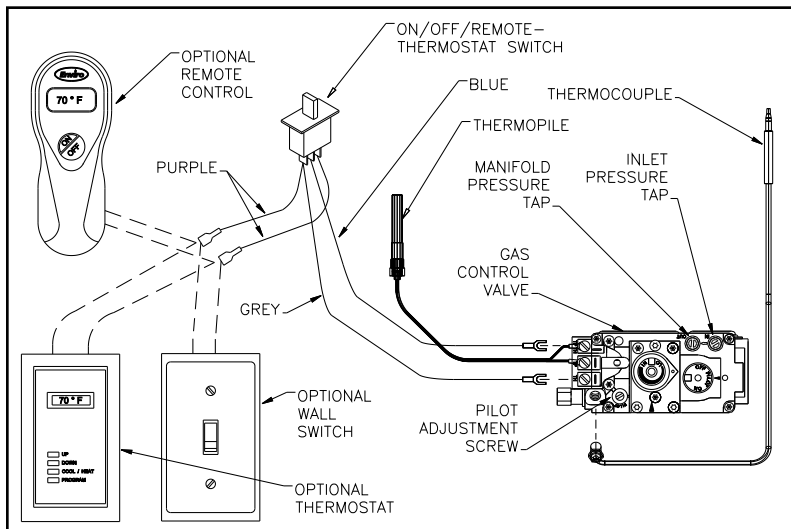

Figure 27: Wiring of a Thermostat

Table 4. Recommended Thermostat Wire Size.

Wire Size	Max. Length
14 gauge	100 ft (30.48 m)
16 gauge	60 ft (18.29 m)
18 gauge	40 ft (12.00 m)
20 gauge	25 ft (7.62 m)
22 gauge	18 ft (5.49 m)

# INITIAL INSTALLATION

## REPLACING THE BLOWER:

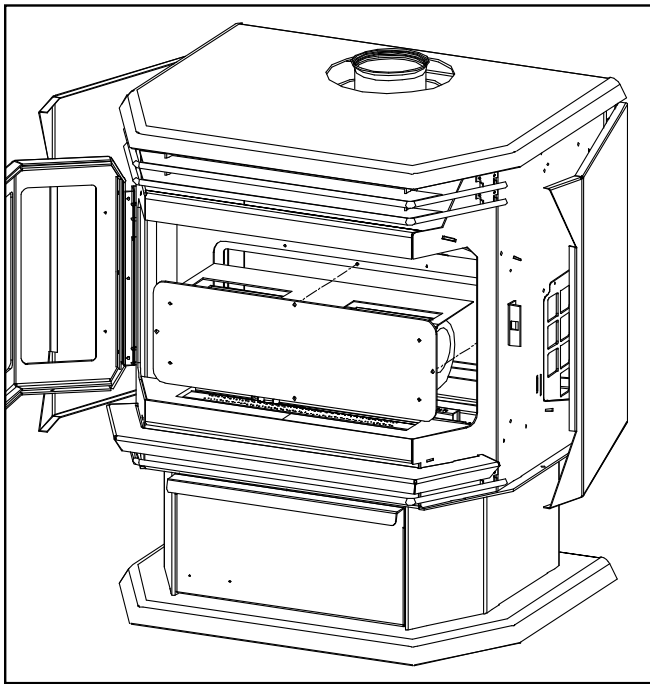

Figure 28: Blower (Fan) Removal.

1. Turn the unit off and remove the log set.
2. Remove the brick liner.
3. Remove the burner tray assembly by removing the screw on either side of the tray, between the front and rear burners. Lift the tray out.
4. Remove the four (4)  $\frac{5}{16}$ " bolts that hold the blower mounting plate to the back firewall. Use a light lubricating oil on screws before removal.
5. Carefully pull the blower assembly into the firebox (see Figure 28) disconnect the blower leads from the harness and remove blower.
6. To re-install, check mounting plate gasket if damaged replace with new one and reverse steps 1 through 4. Refer to "Secondary Installation - Installation of Panel Set" and "Secondary Installation - Installation of Log Set and Embers".

## ADJUSTING THE VENTURIES:

- There is a separate venturies for each burner, see Figure 29.
- Remove one screw from the cover plate located below the ash shelf and loosen the other screw (do not remove) swing the cover plate out of the way and tighten screw down to hold it in place.
- With along screwdriver rotate spring clips to open or close the venturies to the desired setting.

The venturies allows the amount of air coming into the fireplace to be adjusted in order to accommodate different climates and venting arrangements. Start the pilot and then the burner. Make sure the pilot flame is burning normally and none of the burner ports are plugged. Let the fireplace burn for roughly fifteen minutes and then examine the flames, compare the flames to Figure 36.

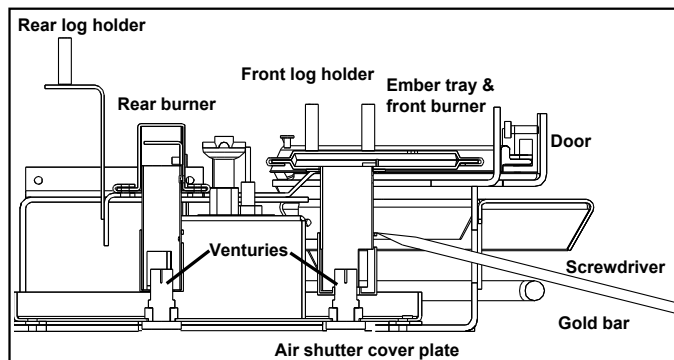

Figure 29: Venturi Adjustment.

The ideal flame will be blue at the base and light orange above. The flames should be of medium height. If the flames look like this, no venturi adjustment is needed. If the flames are fairly short and mostly blue, the fireplace is getting too much air. Therefore, the venturies should be closed slightly until the correct flames are achieved. Flames that are very orange, with tall, dark, stringy tips, are not getting enough air. Open the venturi until the flames clean up. If the venturi is opened, or closed all the way, and the correct flames cannot be attained, turn off the gas and contact the dealer.

**Warning:** Incorrect venturi adjustment may lead to improper combustion, which is a safety hazard. Contact the dealer if there is any concern about the venturi adjustment.

# INITIAL INSTALLATION

## FUEL CONVERSION:

**WARNING: This conversion kit shall be installed by a qualified service technician in accordance with the manufacturer's instructions and all applicable codes and requirements of the authority having jurisdiction. If the information in these instructions is not followed exactly, a fire, explosion or CO poisoning may result. The qualified service agency is responsible for the proper installation of this kit. The installation is not proper or complete until the operation of the converted appliance is checked as specified in the owner's conversion kit.**

Please read and follow these instructions. Also please read the instruction guidelines provided by S.I.T on how to remove and install the HI-LOW regulator.

- STEP 1. Carefully inspect all parts supplied with this conversion kit.
- STEP 2. Shut the gas off and disconnect the main gas line from the unit.
- STEP 3. Open the door by unscrewing the 1/2" bolt on the right hand side of the stove. Lift door off the hinges mounted on the left-hand side.
- STEP 4. Carefully remove the log set and ember material if they are installed.
- STEP 5. Remove the two (2) T-20 screws on the burner tray located between the front and rear burners.
- STEP 6. Change the regulator on the top of the gas valve. (Follow the instructions provided by S.I.T)
- STEP 7. To change the pilot, pull the pilot hood straight up to access the pilot injector, using a 5/32" Allen key, remove the pilot injector.
- STEP 8. Install new pilot injector supplied with the conversion kit. Screw the new injector inside the pilot assembly and re-install the hood by placing the hood on the assembly, line up the keyway and snap into place
- STEP 9. Remove the two (2) main burner orifices using a 1/2" deep socket.
- STEP 10. Install the two (2) new orifices supplied making sure that the orifices are in the correct location. Be sure to put a bead of pipe thread sealant or approved Teflon tape on the orifices before installing them into the burner assembly.
- STEP 11. Re-install burner tray, log set and door. Also refer to "Installing Log Set and Embers."
- STEP 12. Reconnect the gas line to the unit. Do a leak check using soap and water solution or an approved method on the gas supply and the pilot tubing.
- STEP 13. Re-light the appliance to ensure proper operation and proper flame appearance. Be sure to adjust the venturi setting to achieve an efficient flame in the fireplace.
- STEP 14. MAKE SURE that the sticker provided by S.I.T is installed to signify that this valve has been converted to a different type of fuel. Also make sure that the rating plate has a conversion label to show that this unit has been converted to a different fuel type.

A VISUAL CHECK OF THE REGULATOR KNOB IS NECESSARY TO DETERMINE WHETHER OR NOT THE REGULATOR IS THE CORRECT PART. A 50% TURN DOWN REGULATOR WILL HAVE ONLY ONE CORNER ON THE KNOB.

- 1 - 50% turn down HI-LOW Regulator
- 3 - T-20 Torx screws
- 1 - T-20 tamper proof Torx screwdriver bit
- 1 - pilot injector
- 2 - Main orifice
- Labels to show conversion.

**Table 5: Orifice Information.**

	Natural Gas	Propane
Pilot Orifice	.62 mm	.35 mm
Burner Orifice Front	#48 DMS	#55 DMS
Burner Orifice Rear	#43 DMS	#54 DMS
Venturi Setting Front	1/8" min.	3/16" min.
Venturi Setting Rear	3/16" min.	1/2" Min

# INITIAL INSTALLATION

## GAS LINE CONNECTION AND TESTING:

**WARNING:** Only persons licensed to work with gas piping may make the necessary gas connections to this appliance.

### GAS LINE CONNECTION

- This stove is equipped with a certified flexible pipe located on the right side of the unit terminating in a 3/8" male NPT fitting. Consult your local authorities codes or the CAN/CGA B 149 (1 or 2) installation code in Canada, or in the USA gas installations follow either local codes or the current edition of the National Fuel Gas Code ANSI Z223.1.
- The efficiency rating of this appliance is a product thermal efficiency rating determined under continuous operating conditions and was determined independently of any installed system.

The appliance and its shutoff valves must be disconnected from the gas supply piping system during any pressure testing where the pressure exceeds 1/2 PSIG (3.45 KPa) or damage will occur to the valve.

The appliance must be isolated from the gas supply piping system by closing its individual manual shutoff valve during any pressure testing of the gas supply piping system at test pressures equal to or less than 1/2 psig (3.45 KPa).

**Always check for gas leaks with a soap and water solution after completing the required pressure test.**

### TO TEST VALVE PRESSURES

The pressure taps are located on the left side of the valve

- Turn set screw 1 turn counter clockwise to loosen,
- Place 5/16" (8 mm) I.D. hose over pressure tap system.
- Check pressures using a manometer.
- When finished, release pressure, remove hose & tighten setscrew.

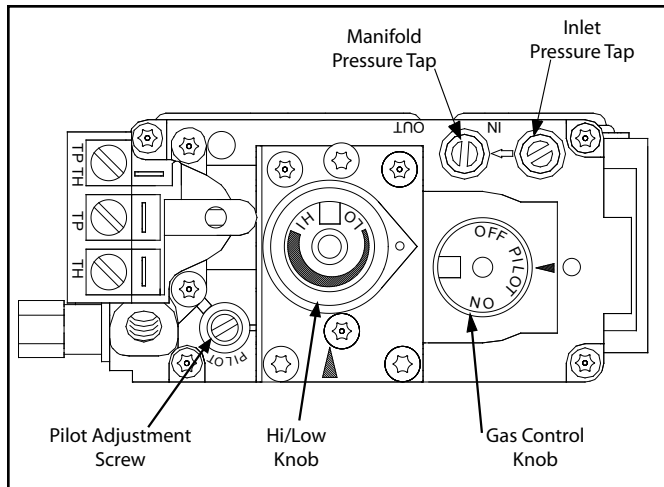

**Figure 30: Fully Labeled Gas Valve.**

**Table 6: Pressure and BTU Information.**

	<b>Natural Gas</b>	<b>Propane</b>
<b>Front Burner</b>	#48 DMS	#55 DMS
<b>Rear Burner</b>	#43 DMS	#54 DMS
<b>Manifold Pressure</b>	3.8" W.C. (0.95 KPa)	11.0" W.C. (2.7KPa)
<b>Min. Manifold Pressure</b>	1.1" W.C. (0.27KPa)	2.7" W.C. (0.67KPa)
<b>Max Supply Pressure</b>	7.0" W.C. (1.74KPa)	12.0" W.C. (2.98KPa)
<b>Min. Supply Pressure</b>	5.0" W.C. (1.24KPa)	11.5" W.C. (2.86KPa)
<b>Max BTU/hr Input</b>	38,000 BTU/hr (11.1KW)	38,000 BTU/hr (7.76KW)
<b>Min. BTU/hr Input</b>	20,000 BTU/hr (5.9 KW)	20,000 BTU/hr (5.9KW)

**NEVER USE AN OPEN FLAME FOR LEAK TESTING.**

# SECONDARY INSTALLATION

## INSTALLATION OF LOG SET AND EMBERS:

The placement of the logs is not arbitrary. If they are positioned incorrectly, the flames can be “pinched” and will not burn correctly. The burner come with five (5) locator pins, and the rear log has one (1) ledge, which make alignment easier. Using the pictures provided, carefully set the logs in place.

**NOTE: The logs are fragile and should be handled gently.**

**CAUTION:** Use only the type of ember material supplied with this appliance. Due to the irregular size of the ember material there may be more than required. The use of other foreign materials on the burners may create dangerous conditions.

If over time, through cleaning and servicing, these embers require replacement, contact the nearest ENVIRO dealer for replacement embers.



Figure 31: Step 1 of Log Placement.

1. The embers can be place before or after the logs are placed. A bag of ceramic fiber embers and rock wool embers is provided gently remove the ember material from the plastic bag. Spread a layer loosely in a random manner across the burner tray. Do not allow any embers to rest against pilot assembly. (See Figure 32 or 35 for proper ember placement.)

DO NOT pack this ember material as this could create an unsafe condition, leave embers loose

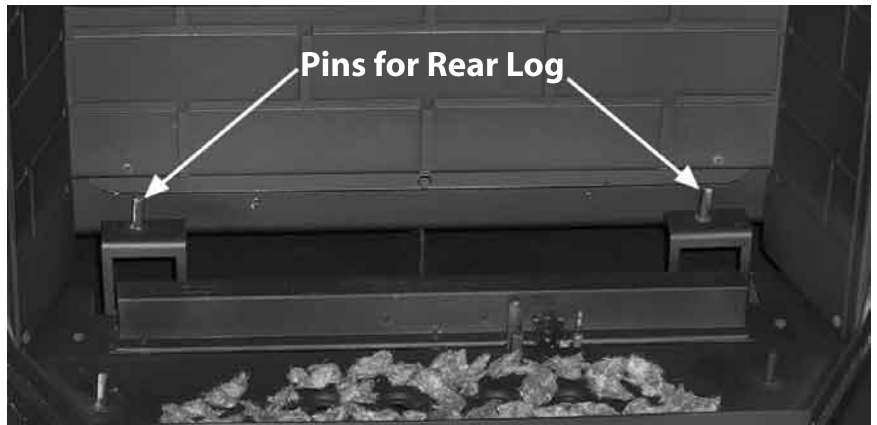

Figure 32: Step 2 of Log Placement.

2. Carefully remove logs from box. Check to ensure there is no damage. It is very important to install all logs in their proper position to insure safe, optimum operating conditions.

3. Place the log set into the firebox. Locate each log by seating it down onto the burner tray support pins. Follow Figures 31 to 35 proper log placement.

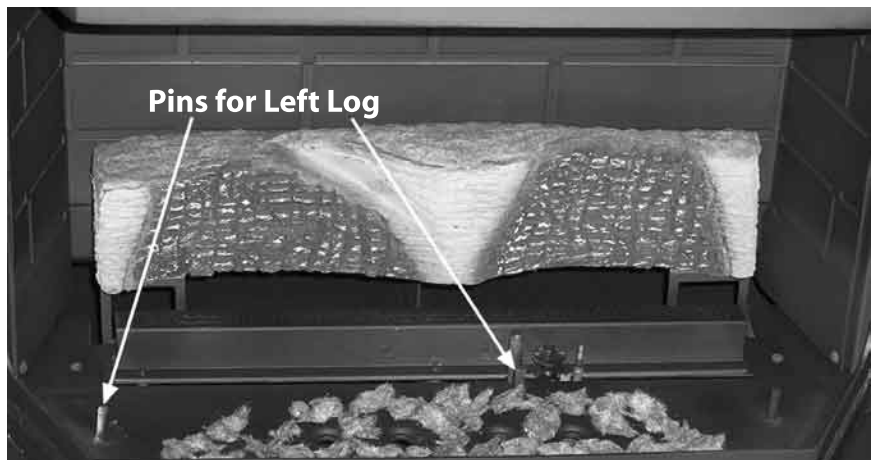

Figure 33: Step 3 of Log Placement.

## SECONDARY INSTALLATION

4. Upon the first light up, watch for ignition to **ALL** burner ports. If a long delay is noted: First, wait for the appliance to cool down.

- Open the front door of the appliance.
- Check to carefully reposition the embers making sure that burner ports are not plugged solid or blocked.

**Important note:** When the unit is turned on for the first time, It should be turned onto high without the fan on for the first 4 hours. This will cure the paint, logs, gasket material and the other products used in the manufacturing process. It is advisable to open a window or door, as the unit will start to smoke and can irritate some people. After the unit has gone through the first burn turn the unit off including the pilot, let the unit get cold then remove the glass door and clean it with a good gas fireplace glass cleaner, available at your local ENVIRO dealer.

See Routine Maintenance And Service on how to remove door to clean glass.

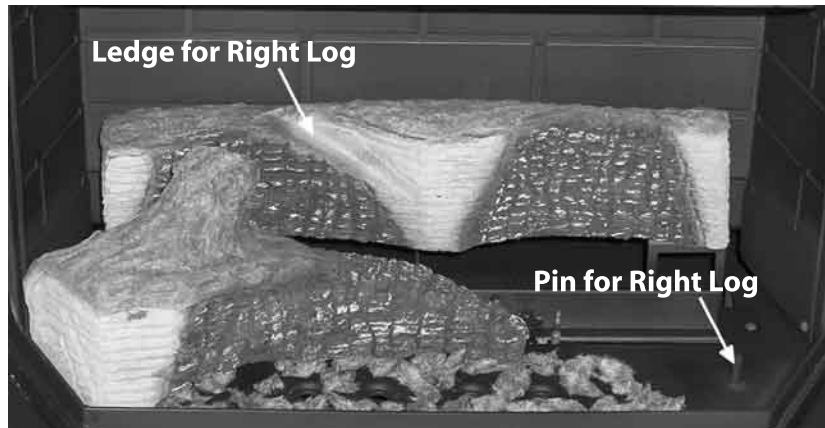

**Figure 34: Step 4 of Log Placement.**



**Figure 35: Log Placement with Embers.**



**Figure 36: Appliance Burning.**

**CAUTION: NEVER OPERATE THIS APPLIANCE WITH THE GLASS DOOR REMOVED.**



# OPERATING INSTRUCTIONS

## FOR YOUR SAFETY READ COMPLETELY BEFORE OPERATING.



**WARNING: IF YOU DO NOT FOLLOW THESE INSTRUCTIONS EXACTLY, A FIRE OR EXPLOSION MAY RESULT CAUSING PROPERTY DAMAGE, PERSONAL INJURY OR LOSS OF LIFE.**

- A) This appliance is equipped with a pilot that must be lit by hand by following these instructions exactly.
- B) BEFORE LIGHTING smell all around the appliance area for gas, and next to the floor because some gas is heavier than air and will settle on the floor.

### WHAT TO DO IF YOU SMELL GAS:

- Do not try to light any appliance.
  - Do not touch any electrical switch; do not use any phone in your building.
  - Immediately call your gas supplier from a neighbor's phone. Follow the gas supplier instructions.
  - If you cannot reach your gas supplier, call the fire department.
- C) Use only your hand to push in or turn the gas control knob. Never use tools. If the knob will not push in or turn by hand, do not attempt to repair it. Call a qualified service technician. Force or attempted repair may result in a fire or explosion.
- D) Do not use this appliance if any part has been under water. Immediately call a qualified service technician to inspect the appliance and to replace any part of the control system and any gas control which has been under water.

### LIGHTING INSTRUCTIONS:

1. STOP! Read the safety information above.
2. Turn off all electrical power to the appliance.
3. Turn the gas control knob clockwise  to the "off" position.
4. Open door. Wait five (5) minutes to clear out any gas. Close door. If you smell gas including near the floor, STOP! Follow "B" in the above safety information. Leak test all gas joints with soapy water **NEVER USE AN OPEN FLAME FOR LEAK TESTING**. If you don't smell gas go to next step.
5. Find the pilot located to the right between the front and rear burner.
6. Turn gas control knob counter-clockwise  to "PILOT".
7. Push the gas control knob in fully and hold. A BATTERY operated electronic igniter will light the pilot. Keep knob depressed for about 30 seconds after pilot is lit. **Check that the pilot flame has fully engulfed the thermocouple assembly (see Figure 38)**. Release knob. If pilot goes out, repeat steps 4 through 6.

WARNING: The gas valve has an lockout device which will not allow the pilot burner to be re-lit until the thermocouple has cooled.

If the knob does not pop up when released, stop and immediately call your service technician or gas supplier.

If the pilot will not stay lit after several tries, turn the gas control knob to "OFF" and call your service technician or gas supplier.

8. Turn gas control knob counter-clockwise  to the "ON" position. Flip burner switch to "ON". Turn "HI / LO" knob to the desired setting. Turn on all electrical power to the unit. Check that all burner ports have flame.
9. Leak test all gas joints again.

### TURNING GAS OFF TO APPLIANCE:

1. Depress the gas control knob slightly and turn it clockwise  to "PILOT". Repeat to turn to the "OFF" position. DO NOT FORCE
2. Turn off all electrical power to the appliance if service is to be performed.
3. Flip burner switch to off, to turn off burners only.

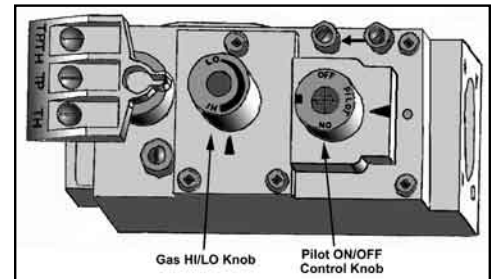

Figure 37: Gas Valve.

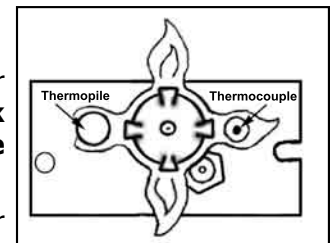

Figure 38: Pilot Burning.

# ROUTINE MAINTENANCE AND SERVICE

Periodically check to ensure that your direct vent system is clean.

Periodically check the pilot and burner. Check to see that all the burner ports are clean and clear. Check the pilot head for blockage. Check to ensure the pilot flame is blue with no or very small yellow tips.

## OPENING THE DOOR

Turn unit off and wait until the appliance has cooled down.

1. Open the right hand hinged side flap, which will expose a door fastener. Using a 1/2" wrench, loosen the fastener.
2. Due to the shape of the bay window door. You must also open the left-hand side flap before attempting to open the door.
3. If the door must be removed open the door and lift the door pins out of the hinges (see figure 39).
4. Ensure the door is properly fastened after cleaning before attempting to re-light the appliance.

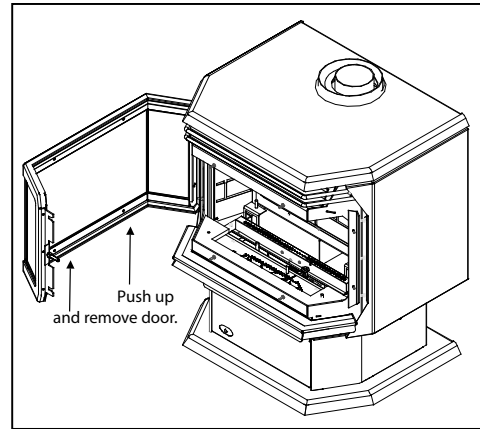

**Figure 39: Removing the Door.**

## CLEANING THE GLASS (Allow the glass to cool before cleaning.)

It will be necessary to clean the ceramic glass periodically. During a cold start up, condensation will sometimes form on the glass. This is a normal condition with all gas fireplaces and stoves. However, this condensation can allow dust and lint to cling to the glass surface. Initial paint curing of the appliance can leave behind a slight film on the glass. This is a temporary problem. It is therefore recommended that the glass be cleaned initially after about the first four hour of use.

Depending upon the amount of use, cleaning should be required no more than two or three times per season.

To clean the door, use a mild glass cleaner and a soft cloth or a glass cleaner available from your Enviro dealer. Abrasive cleaners will damage the glass.

## TO REPLACE DOOR

The glass in this appliance is an integral part of the door assembly. If the glass is damaged or broken a replacement inner door with glass assembly must be purchased.

The glass in this appliance is ceramic. If the glass is damaged or broken a factory door with glass replacement must be used.

Remove the door with glass, a new door assembly must be purchased from an ENVIRO dealer (part #: EC-063). **Do not use a substitute materials; it will void the warranty.**

## CLEANING THE INSIDE OF THE FIREBOX

1. Turn off the unit and allow it to cool down completely.
2. Remove the logs carefully from the firebox. Gently remove the embers and place on a piece of paper towel, until ready to replace.
3. Vacuum the bottom of the firebox thoroughly. Carefully clean off any dust on the logs and remove any lint from the main burner and pilot burner.
4. After carefully replacing the log and embers in their correct positions (see Secondary Installation - Installation of Log Set and Embers), and the door has been resealed, re-light the pilot, following the instructions on the lighting label attached to the unit.

## CLEANING PLATED SURFACES:

It is important to note that fingerprints and other marks can leave a permanent stain on plated finishes. To avoid this, give the face a quick wipe with denatured alcohol on a soft cloth BEFORE lighting the fireplace. Never clean the face when it is not cool. Do not use other cleaners as they may leave a residue, which can become permanently etched into the surface.

# TROUBLE SHOOTING

<b>Problem</b>	<b>Possible Cause</b>	<b>Solution</b>
Spark will not light the pilot after repeatedly pressing the spark ignitor	Defective piezo ignitor.	<ul style="list-style-type: none"> <li>• Check connections to ignitor.</li> <li>• If ignitor connections are good but there is no spark; replace ignitor.</li> </ul>
	Broken spark electrode.	<ul style="list-style-type: none"> <li>• Check for broken ceramic insulation.</li> <li>• Replace electrode if broken.</li> </ul>
	Misaligned spark electrode.	<ul style="list-style-type: none"> <li>• If spark is not arcing from electrode to pilot - adjust by loosening the screws on the pilot base. Adjust away from burner and retighten.</li> </ul>
Pilot will not remain lit	Problem with thermocouple circuit.	<ul style="list-style-type: none"> <li>• Check for proper connection of the thermocouple to the rear of the valve. If loose, tighten lightly.</li> <li>• Check pilot for full flame impingement around thermocouple. If flame is too small, check gas pressure, adjust pilot rate screw, check pilot head for damage or blockage.</li> <li>• Check thermocouple voltage at rear of valve. It must be greater than 5 mV. If low, replace thermocouple.</li> </ul>
	Air in gas line (pilot dies while knob is depressed).	<ul style="list-style-type: none"> <li>• Bleed line.</li> <li>• Check gas line pressure.</li> <li>• Contact dealer.</li> </ul>
Burners will not remain lit	Problem with thermopile circuit.	<ul style="list-style-type: none"> <li>• Check gas line pressure .</li> <li>• Check for flame impingement on thermopile. If low, see "Pilot will not remain lit".</li> <li>• Check thermopile for minimum of 200 mV when burner is switched on.</li> <li>• Check wiring to thermostat for breaks.</li> </ul>
Flame lifting	Leak in vent pipe.	<ul style="list-style-type: none"> <li>• Check for leaks in vent connections.</li> </ul>
	Improper vent configuration.	<ul style="list-style-type: none"> <li>• Check vent configuration with manual.</li> </ul>
	Terminal may be recirculating flue gases.	<ul style="list-style-type: none"> <li>• Check to see if the terminal is on correctly.</li> <li>• May need to install high wind termination cap.</li> <li>• Contact dealer.</li> </ul>
Glass fogs up	Normal Condition: after the appliance warms up the glass will clear. **Due to additives in gas, glass may get hazy during operation** Clean as needed.	
Blue Flames	Normal during start up: flames will yellow as the fireplace heats up.	
Flames are burning "dirty" or sooting	Flame impingement	<ul style="list-style-type: none"> <li>• Check log positioning.</li> <li>• See also "Burners will not remain lit."</li> </ul>
Flame goes out / comes on frequently during a short period of time.	Defective rocker switch.	<ul style="list-style-type: none"> <li>• Check rocker switch connections.</li> <li>• Replace switch if necessary.</li> </ul>

# PARTS LIST

Reference Number	Part Description	Part Number
1	120 °F (49 °C) Ceramic Temperature Sensor	EC-001
2	S.I.T. NOVA Valve NG (50% turn down)	EC-006
2	S.I.T. NOVA Valve LP (50% turn down)	EC-007
3	Thermocouple	EC-009
3	Spark Electrode with Ignitor Cable	EC-011
3	Thermopile	EC-012
3	Fully Assembled Pilot NG	EC-015
3	Fully Assembled Pilot LP	EC-016
3	Pilot Orifice NG Threaded	EC-019
3	Pilot Orifice LP Threaded	EC-020
	Pilot Gasket	EC-021
4	S.I.T. Piezo Ignitor	EC-023
	Stainless Steel Flex Connector with 3/8" Elbow 18" Long	EC-024
5	Burner Switch	EC-025
6	Miniature Light Bulb (115V)	EC-031
6	Light Bulb Holder	EC-032
	Wiring Harness Complete (2 pieces)	EC-037
	Body Wiring Harness	EC-037A
	Burner Wiring Harness	EC-037B
	Fan Control Knob	EC-040
	IEC Power Cord - 115V	EC-043
	4 oz. Bag Coal Embers Only	EC-045
7	1" x 1" Side Cabinet Hinge	EC-054
	Pedestal Door Magnet	EC-056
	3/8" Tadpole Door Gasket (7 ft)	EC-057
	Window Channel Tape 72"	EC-058
8	Door Latch Bolt	EC-059
	Simpson Duravent GS Adapter	EC-060
	Freestanding Direct Vent Kit with Coupler	EC-061
9	Inner Door with glass	EC-063
10	Light Switch	EC-066
	Vent Restrictor Ring	EC-067
11	Fan Controller with Knob - 115V	EF-045
	Latch Bracket & Nut	EG40-023
12	Convection Air Deflector	EG40-033
	Side Panel Magnet	EG40-049

# PARTS LIST

---

Reference Number	Part Description	Part Number
	Fan Access Cover Gasket	EG40-066
	DV Owner's Manual	EG40-070
13	Pedestal	EG40-080
14	Side Panel	EG40-086
15	DV Stove Top	EG40-087A
	Firebox Baffle	EG40-088
	Stove Top Baffle DV	EG40-091A
	Venturi Cover Plate	EG40-097
16	Front Venturi	EG40-098
17	Bar Set - Painted (3 pieces)	EG40-114
17	Bar Set - Gold (3 pieces)	EG40-115
17	Bar Set - Nickel (3 pieces)	50-478
	Burner Gasket	EG40-120
	Steel Brick Liner	EG40-129
	Brick Liner Backing	EG40-130
18	Pedestal Door	EG40-135
	LP to NG Conversion Kit	EG40-200
	NG to LP Conversion Kit	EG40-202
19	Ash Sill	EG40-213
20	Door Hinge (Set of 2)	EG40-302
21	Fan Mount	EG40-304
22	Pedestal Box Cover	EG40-307
23	Burner Control Assembly NG	30-014
23	Burner Control Assembly LP	30-015
24	Front Pan Burner	30-016
25	Rear Burner with Venturi	30-017
	Pilot 1/8" Tube with Ferules	30-043
	Log Set Complete	50-081
26	Blank Orifice #73	50-343
27	Door Cover - Gold	50-480
27	Door Cover - Painted	50-776
27	Door Cover - Brushed Nickel	50-1063
28	Convection Blower - 115V	50-514
	16" Ignitor Wire	50-652
	IEC Power Cord Inlet Socket	50-713
	Burner Tray Top NG & LP	50-774
	Vent Termination Kit	50-950

# PARTS DIAGRAM - CHASSIS

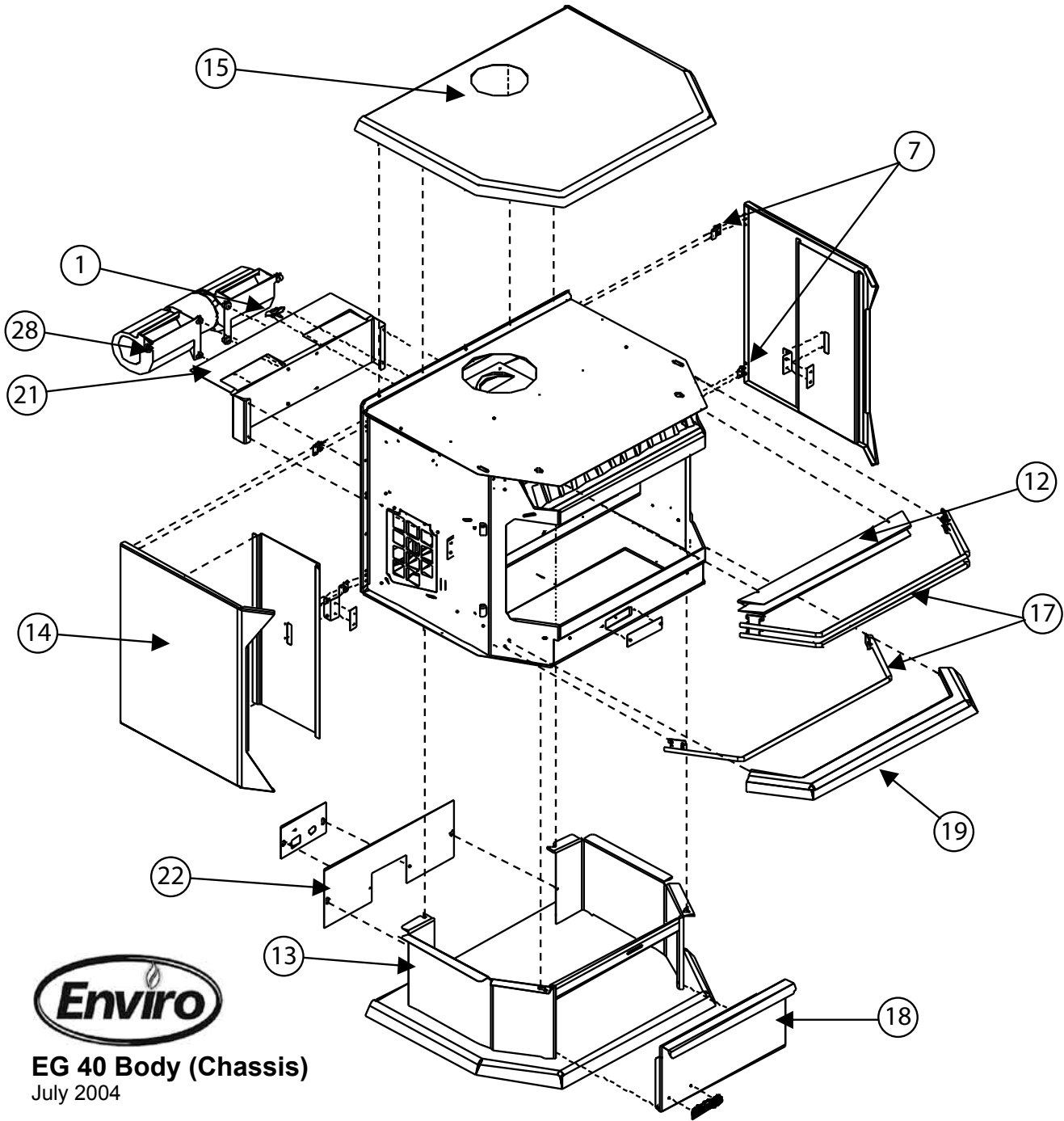

**EG 40 Body (Chassis)**  
July 2004

# PARTS DIAGRAM - GAS TRAY & DOOR



EG40 Gas Tray & Door Assemblies  
July 2004

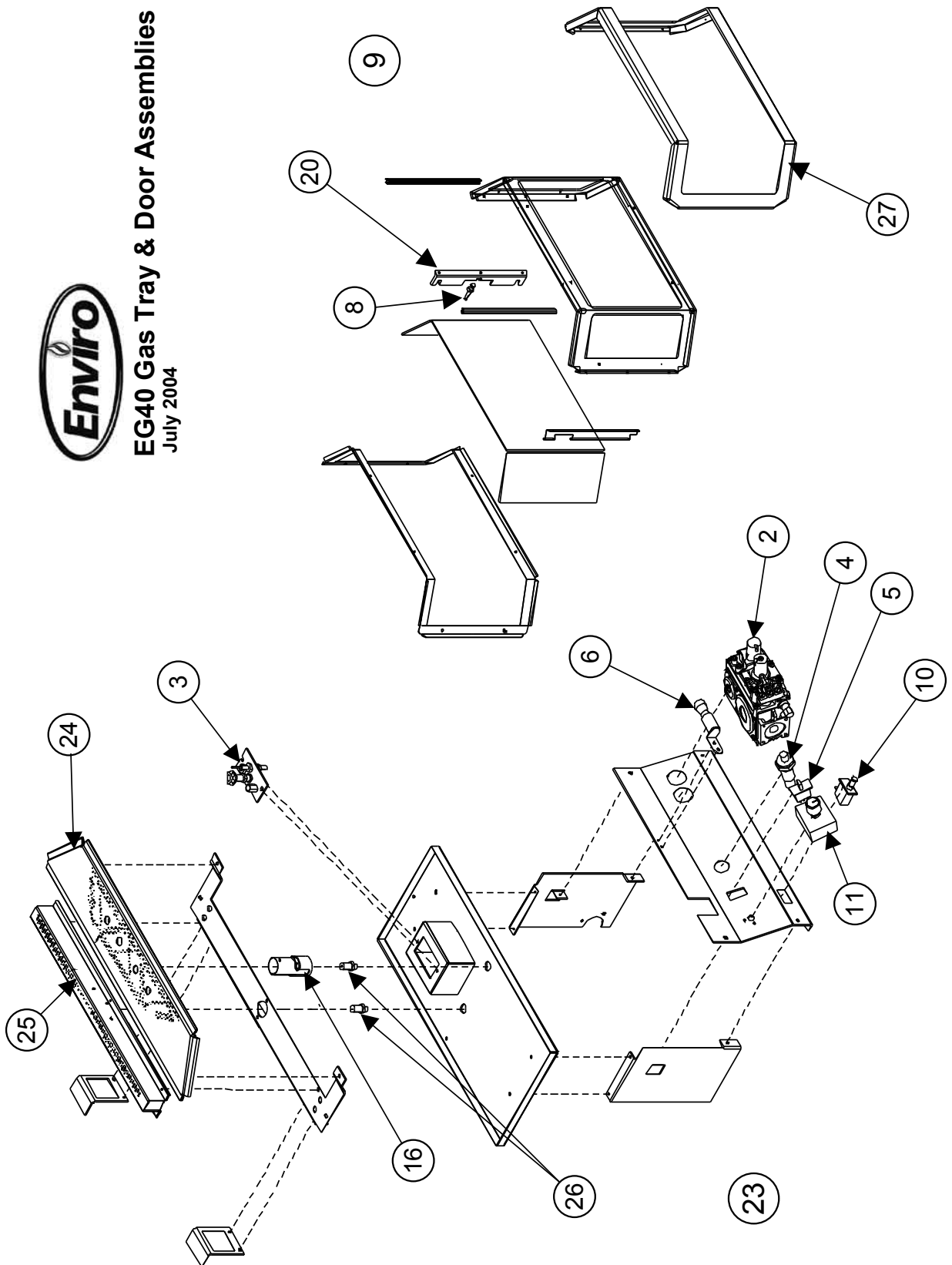

# WARRANTY

---

Sherwood Industries Ltd. offers a Limited Lifetime Warranty on this gas product. This limited lifetime warranty covers the appliance for a period of seven years from the date of installation. This warranty applies only to the original owner in the original location

Covered under the lifetime warranty are Cabinet Sides, Tops, Pedestals, Surround Panels and Chassis and Heat Exchanger. These steel components are covered against manufacturer's defects for 5 years and labor for the first year and for parts only thereafter.\* The following exclusions apply:- over-firing due to incorrect setup or tampering, damage caused by incorrect installation, usage or abuse. The unit must be properly installed by a qualified technician or installer, and must meet all local and national gas and building code requirements.

We also cover against manufacture defects under our lifetime warranty. The following components, Gold Plating, Log Set, Burners and Glass (\*) The following exclusions apply:

Gold plating- Damage caused by scratching, marring, chemicals, fingerprints, abrasive cleaners or discoloration with age or over-firing

Glass- use of harsh or abrasive cleaners, striking the glass or surface contaminates.

Log-set- Damage caused by incorrect handling or misuse.

Burners- damage caused by improper or continuous operation under incorrect conditions.

The paint on the Metal Brick Liner may peel. This is due to the extreme conditions applied to the paint and is no way covered under warranty.

\* TO A MAXIMUM OF SEVEN YEARS

Sherwood Industries Ltd. offers a 2-year warranty on all the Electrical Components and Gas Components against manufacturing defects. Paint is covered against flaking. This offer includes parts and labor for 1 year and for parts only thereafter.

Your dealer shall make all claims under this warranty in writing.

## **WHEN FILING A WARRANTY CLAIM PLEASE COMPLETE THE FOLLOWING INFORMATION ON AN OFFICIAL WARRANTY CLAIM FORM:**

### **TO THE DEALER**

Name, address and telephone number of purchaser and date of purchase.

Date of installation. Name of installer and dealer. Serial number of the appliance. Nature of complaint, defects or malfunction, description and part numbers of any parts replaced.

### **TO THE DISTRIBUTOR**

Sign and verify that work and information are correct.

This warranty covers defects in materials and workmanship only if the product has been installed according to the manual's instructions. If the product is damaged or broken as a result of misuse or mishandling the warranty does not apply. The warranty does not cover removal and re-installation costs.

Sherwood Industries Ltd. reserves the right to repair or to replace the defective product. The shipping costs are to be paid by the consumer. All warranties by the manufacture are set forth herein and no claim shall be made against the manufacturer on any oral warranty or representation.

Sherwood Industries Ltd. and its employees or representatives will not assume any damages, either directly or indirectly caused by improper usage, operation, installation, servicing or maintenance of this appliance.

Sherwood Industries Ltd. reserves the right to make changes without notice. Please complete and mail the warranty registration card and have the installer fill in the installation data sheet in the back of the manual for warranty and future reference.



# INSTALLATION DATA SHEET

The following information must be recorded by the installer for warranty purposes and future reference.

NAME OF OWNER:  
\_\_\_\_\_  
  
ADDRESS:  
\_\_\_\_\_  
\_\_\_\_\_  
\_\_\_\_\_  
  
PHONE: \_\_\_\_\_

NAME OF DEALER:  
\_\_\_\_\_  
  
ADDRESS:  
\_\_\_\_\_  
\_\_\_\_\_  
\_\_\_\_\_  
  
PHONE: \_\_\_\_\_

MODEL: \_\_\_\_\_  
SERIAL NUMBER: \_\_\_\_\_  
DATE OF PURCHASE: \_\_\_\_\_ (dd/mm/yyyy)  
DATE OF INSTALLATION: \_\_\_\_\_ (dd/mm/yyyy)  
  
 NATURAL GAS (NAT)       PROPANE(LPG)  
  
INLET GAS PRESSURE: \_\_\_\_\_ in wc  
MAIN BURNER ORIFICE: \_\_\_\_\_ # DMS  
PILOT ORIFICE # \_\_\_\_\_ OR \_\_\_\_\_ in diam.  
  
INSTALLER'S SIGNATURE:  
\_\_\_\_\_

NAME OF INSTALLER:  
\_\_\_\_\_  
  
ADDRESS:  
\_\_\_\_\_  
\_\_\_\_\_  
\_\_\_\_\_  
  
PHONE: \_\_\_\_\_

MANUFACTURED BY:  
SHERWOOD INDUSTRIES LTD.  
6782 OLDFIELD RD. SAANICHTON, BC, CANADA V8M 2A3  
[www.envirofire.biz](http://www.envirofire.biz)  
February 21, 2005  
C-10365