

OCEANAIRE

CONVERTIBLEAIRE Deluxe Portable Heat Pump

ENGINEERING, INSTALLATION AND SERVICE MANUAL



20ACH-Series

R410A Models



OCEANAIRE

6228 Oakton Street Morton Grove, IL. 60053 Phone 847-583-0311 (or 0317) Fax 847-583-0312
E-Mail sales@oceanair-inc.com 1-866-GET-AIRE (438-2473) www.oceanair-inc.com

<u>TABLE OF CONENTS</u>	PAGE
GENERAL DESCRIPTION	1
PRODUCT DATA AND SPECIFICATIONS.....	2
UNIT DESCRIPTION	
Standard Features.....	3
Applications / Operation.....	4-5
Electrical.....	6
Use of Extension Cords.....	7
Condensate.....	8
Accessories.....	9 - 15
Installation.....	16
Electronic Controller.....	17-19
SERVICE	
Replacement Parts Procedure.....	20
Troubleshooting Guide.....	21
Preventive Maintenance.....	22
Interior View.....	23
Piping Schematic.....	24
DIAGRAMS	
Wiring Diagrams.....	25 - 31
Three Phase Monitor.....	32

FORWARD

This manual provides the user with basic details for the installation and operation of the Oceanaire CONVERTIBLEAIRE spot cooler. It is recommended to read and fully understand the instructions outlined within this manual, before operating the CONVERTIBLEAIRE unit.

As with all commercial air conditioning equipment, it is recommended to have the CONVERTIBLEAIRE sized and installed by a licensed specifying engineer and contractor, in accordance with all local and state codes. The length of service received can be extended by following the installation and preventive maintenance instructions.

NOTICE

In our ongoing process of continuous improvement, the items and procedures described in this manual are subject to change without notice. Please note model and serial number of the CONVERTIBLEAIRE unit when contacting the factory.

GENERAL DESCRIPTION

The Oceanaire CONVERTIBLEAIRE is a portable air-cooled heat pump designed for permanent or temporary spot cooling or heating applications. The entire air conditioning unit has been built in an premium sheet metal cabinet, equipped with heavy-duty casters for mobility. All CONVERTIBLEAIRE models come with a 10-foot power cord for electrical connection and added mobility in service. These heat pumps direct cooled or heated air to specific areas or objects through a discharge grill located on the upper-front of the unit, while rejecting heat/cool from the top of the unit. The CONVERTIBLEAIRE models range in capacities from 12,000 BTU/HR to 60,000 BTU/HR to satisfy most space cooling or heating requirements.

The CONVERTIBLEAIRE is a self-contained unit with the entire heat pump system, evaporator and condenser fan motors and electrical components neatly arranged in a gray and blue polyester powder coated metal cabinet. When connected to the proper source of electrical power, the CONVERTIBLEAIRE is controlled by a solid-state electronic controller, with numerous options of temperature and air-flow controls that will provide the desired level of comfort when cooling or heating.

A wide variety of accessories and factory installed options are available for the CONVERTIBLEAIRE units allowing for improved performance and added versatility.

NOMENCLATURE

20 AC H 24 1 2



CAPACITY RATING

- 12.....12,000 BTU/HR
- 18.....18,000 BTU/HR
- 24.....24,00 BTU/HR
- 36.....36,000 BTU/HR
- 60.....60,000 BTU/HR

WARRANTY CARD

It is important that the warranty card be filled out completely and returned to the factory within fourteen (14) days of installation of the unit in order to receive the benefits of the warranty.

ConvertibleAire

Deluxe Air-Cooled Portable Heat Pumps

SPECIFICATIONS

MODEL: 2OACH	1211	1811	2412	3612	3632	3634	6012	6032	6034	
Cooling Capacity ¹	11,800	16,800	24,020	36,050	36,050	36,050	60,050	60,050	60,050	
Heating Capacity ¹	11,800	16,800	24,020	36,050	36,050	36,050	60,050	60,050	60,050	
Voltage (V/Phase) at 60Hz	115/1		208-230/1	208-230/1	208-230/3	460/3	208-230/1	208-230/3	460/3	
Cooling Amps ⁶	10.4	14.1	14.9	18.1	17.2	8.7	32.0	20.4	14.8	
Cooling Watts ⁶	1180	1670	2700	3620	3620	3620	6000	6000	6000	
In Rush Current (Amps)	77.5	100.5	90	140	122	122	169	140	140	
Plug Type	5-15P	5-20P	6-20P	6-30P	L15-30P	L16-20P	6-50P	L15-30P	L16-20P	
EER ³	10.0	10.0	8.9	10.0	10.0	10.0	10.0	10.0	10.0	
Compressor HP	1	1 1/2	2	3	3	3	5	5	5	
Compressor RLA	9.5	12.3	10.5	13.6	8.8	5.0	27.6	18.1	9.0	
Compressor LRA	50	63	48	83	77	35	158	137	62	
Evap CFM ⁴	400	600	810	1310	1310	1310	1950	1950	1950	
Evap Motor HP	1/8	1/8	1/3	1/3	1/3	1/3	1	1	1	
Evap Motor Watts	200	210	350	375	375	375	550	550	550	
Condenser CFM	580	930	1010	1390	1390	1390	2200	2200	2200	
Condenser Motor HP	1/8	1/8	1/3	1	1	1	1	1	1	
Condenser Motor Watts	280	450	330	460	460	460	750	750	750	
Condensate	5 Gallon Condensate Tank - STANDARD (Pump Optional)						Pump -STANDARD (20 ft. Lift)			
Sound Level ⁵	54	60	65	69			78			
R-410A Charge Oz.	18	40	37	66			80			
(A) Height with Casters (in.)	36 1/2	44 1/2		50 1/4			52 1/4			
(B) Width (in.)	20	24			28					
(C) Depth (in.)	25	30			35			39		
(D) Height w/o Casters (in.)	32 1/2	39 1/2			45			46		
Net Weight (lb.)	180	260	260	365		380	485	485	515	
Shipping Weight (lb.)	200	285	285	405		420	525	525	555	
Shipping Volume (cu. ft.)	19	28			40		48			

Specifications subject to change without notice

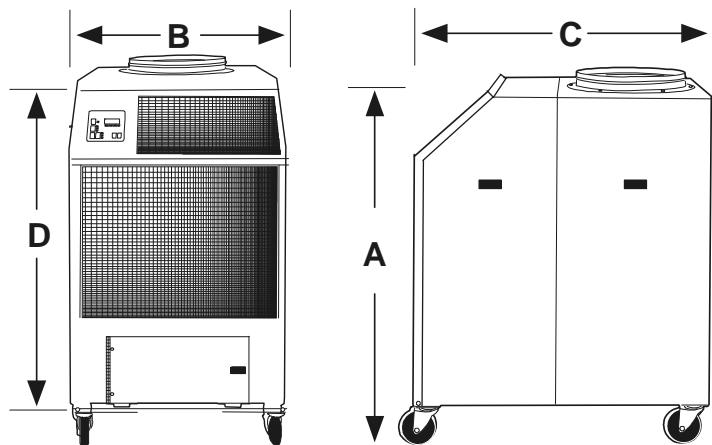

1. Cooling Capacity is total BTUH at 80°DB/67°WB return air, 95°F Outdoor at high fan speed. Heating capacity is total BTUH at 70°F DB/60°F WB (Indoor), 47°F DB/43°F WB (Outdoor)
2. Time Delay fuses/circuit breakers are recommended
3. EER is determined at high fan speed, with condenser discharge air ducted into another area
4. CFM with free discharge
5. Sound Pressure, dB at 5 feet, commercial operation
6. Amps & Watts at 208 Volts

Ambient operating range 65° to 105°

May operate down to 55° if equipped with hot gas bypass (Factory installed)

50 Hz MODELS AVAILABLE - CONSULT FACTORY

Note: Condenser inlet air plenum adds 13 inches to dimension "C"

STANDARD FEATURES

CABINET

The CONVERTIBLEAIRE Series heat pump has a cabinet that is constructed of 18 gauge steel with a polyester powder coated finish that will compliment any decor. The cool blue front compliments any surrounding space, and is insulated with sound-absorbing insulation for cool, quiet comfort. All units come equipped with handles and premium swivel casters for portability and convenient set-up.

DELUXE ELECTRONIC CONTROLLER

Each CONVERTIBLEAIRE unit is equipped with deluxe electronic controller. When power is connected to the unit, the thermostat will control the unit to cool a space to the desired temperature. The thermostat is also capable of controlling the fan to operate automatically (when needed) or continuously.

One additional feature of the Deluxe Electronic Control is that it will display a condition alarm **CON**. **CON** displays when a condensate alarm, or a high pressure reset condition has been met. To protect the compressor from short-cycling, there is a built-in time delay.

FAN SPEED CONTROL

One of the features of the electronic controller is that the unit supply fan can be controlled automatically or manually. In AUTO mode, the indoor blower will adjust air flows automatically for added comfort and performance. Or if desired, the controller can be set to MANUAL fan mode and the indoor blower will run continuously at one of six levels of fan speed.

CONDENSATE RESERVOIR/PUMP

CONVERTIBLEAIRE units come equipped with a means for handling the condensate generated during the cooling/heating process. All models **except the 5-ton models** come equipped with a Condensate Reservoir Tank, that captures the condensate from cooling. The tank can then be easily removed from the unit and emptied as required.

The 2OACH60 models come equipped with an Automatic Condensate Pump that disposes of the condensate. The pump comes with a 20 foot long vinyl hose that allows for the disposal of the condensate water to a drain. The automatic pump is capable of a 20ft lift, to handle almost any installation requirement.

FILTERS

All CONVERTIBLEAIRE units are equipped with washable filters at the air intakes. Electrostatic mesh air filters located behind the evaporator return air grill serve to filter the air before it is cooled, and behind the condenser return air grill to prevent dust build-up. Both filters can be easily removed and cleaned.

HIGH PRESSURE SAFETY SWITCH

Located on the back of the CONVERTIBLEAIRE unit is a manual re-set high pressure switch, used for the protection of the compressor. If the condensing pressure exceeds the limit setting, the cut-out shuts down the compressor, while the evaporator fan remains running. The display will indicate **CON**. The compressor can be re-started, once the condensing pressure has lowered, by depressing the "RESET" button.

POWER CORDS

All CONVERTIBLEAIRE units come with power cords, convenient connection and portability. All units except the 5-ton models, and 3-phase models are equipped with LCDI for added safety devices.

APPLICATIONS

COOLING MODE—SPOT COOLER

The CONVERTIBLEAIRE can be used in an open environment to cool specific objects or "spots". Spot Cooling is a convenient and economical way to provide air conditioning where cooling the entire space is impractical. Cool air is discharged from the unit and is directed where it is needed. Nozzle kits can be used to improve direction of the cooling airflow.

AREA COOLER

When the CONVERTIBLEAIRE is installed in an area that is not totally enclosed, the condenser hot air exhaust duct directs condenser air out of the area, allowing the evaporator air to cool the specific space.

ROOM AIR CONDITIONER

When ducted, the OceanAire CONVERTIBLEAIRE can be used as a room air conditioner to cool an enclosed space. Using the condenser return air plenum (2DCP) and ceiling discharge kit (CK) and ceiling panel kits CK-PL accessories, the 2OACH can operate as a room air conditioner with the condenser air isolated from the conditioned space.

CONVERTIBLEAIRE—COOLING MODE OPERATION / DESCRIPTION

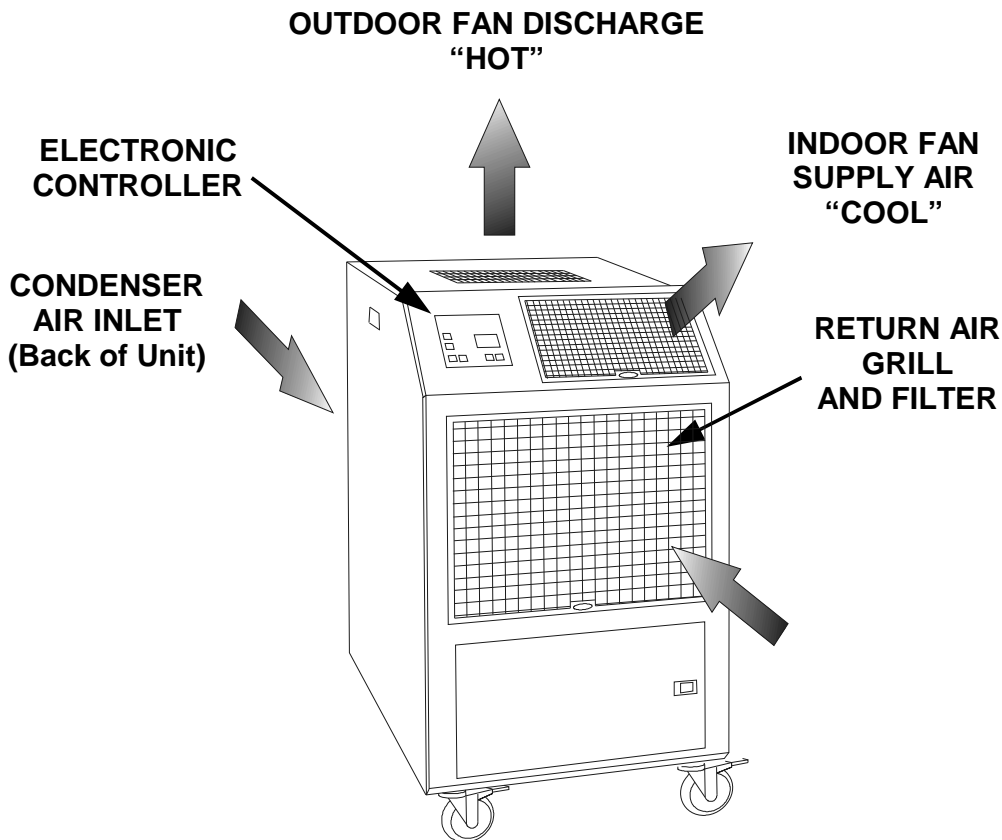

CONVERTIBLEAIRE—COOLING MODE

APPLICATIONS

HEATING MODE—HEAT PUMP

in HEAT mode, The CONVERTIBLEAIRE can be used in an open environment to provide heat to a specific area or "spots". The CONVERTIBLEAIRE is a heat pump, and the supply air will feel warm, but not extremely hot to the touch. Nozzle kits can be used to improve direction of the heated airflow.

CONVERTIBLEAIRE—HEATING MODE OPERATION / DESCRIPTION

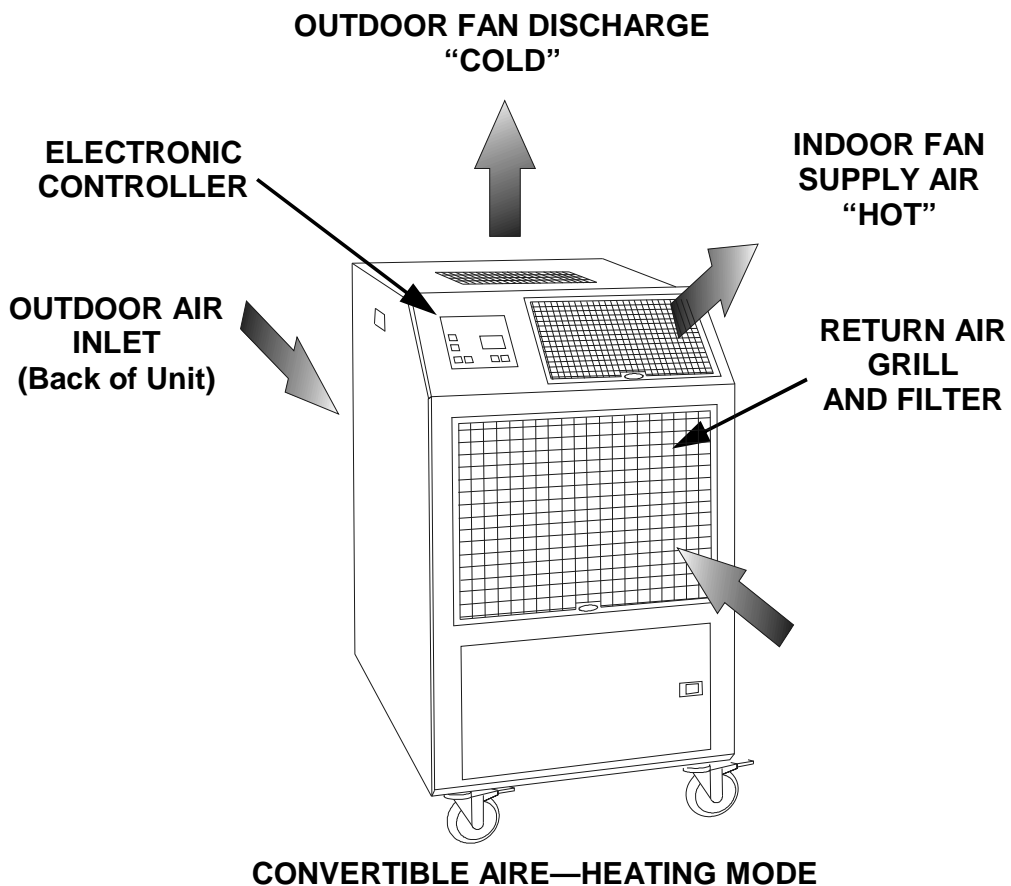







SERVICE CORD

All 2OACH-Series units are equipped with the standard ten foot long service cord with plug configurations and receptacle requirements as shown in this chart. 2OACH1211, 2OACH1811, 2OACH2412 and 2OACH3612 units come with LCDI (Leakage Current Detection & Interruption) devices that serve as a means of electrical protection.

CAUTION—DO NOT USE THE LCDI AS AN ON/OFF SWITCH FOR THE UNIT

All 3-phase models are equipped with locking plugs for added connection reliability. Refer to the chart below for plug and receptacle details for all CONVERTIBLEAIRE models.

A DAMAGED LCDI POWER SUPPLY CORD MUST BE REPLACED WITH A NEW POWER SUPPLY CORD AND NOT REPAIRED

UNIT/MODEL	PLUG CONFIGURATION	RECEPTACLE
<u>115 VOLT</u> 2OACH1211	 15A-125 VOLT NEMA 5-15P	NEMA-5-15R
<u>115 VOLT</u> 2OACH1811	 20A-125 VOLT NEMA 5-20P	NEMA 5-20R
<u>208-230 VOLT SINGLE PHASE</u> 2OACH2412	 20A-250 VOLT NEMA 6-20P	NEMA 6-20R
<u>208-230 VOLT SINGLE PHASE</u> 2OACH3612	 30A-250 VOLT NEMA 6-30P	NEMA 6-30R
<u>208-230 VOLT SINGLE PHASE</u> 2OACH6012	 50A-250 VOLT NEMA 6-50P	NEMA 6-50R
<u>208-230 VOLT 3-PHASE</u> 2OACH3632 2OACH6032	 30A-250 VOLT NEMA L15-30P	NEMA L15-30R
<u>460 VOLT 3-PHASE</u> 2OACH3634 2OACH6034	 20A-460 VOLT NEMA L16-20P	NEMA L16-20R

USE OF EXTENSION CORDS

CAUTION:

FOR MODEL 2OACH1211 AN EXTENSION CORD CAN BE USED PROVIDED IT IS RATED AT LEAST 15 AMPS @ 115 VOLTS WITH GROUNDING-TYPE ATTACHMENT PLUG AND GROUNDING TYPE CONNECTOR (LOAD FITTING)

FOR MODEL 2OACH1811 AN EXTENSION CORD CAN BE USED PROVIDED IT IS RATED AT LEAST 20 AMPS @ 115 VOLTS WITH GROUNDING-TYPE ATTACHMENT PLUG AND GROUNDING TYPE CONNECTOR (LOAD FITTING)

FOR MODEL 2OACH2412 AN EXTENSION CORD CAN BE USED PROVIDED IT IS RATED AT LEAST 20 AMPS @ 250 VOLTS WITH GROUNDING-TYPE ATTACHMENT PLUG AND GROUNDING TYPE CONNECTOR (LOAD FITTING)

FOR MODEL 2OACH3612 AN EXTENSION CORD CAN BE USED PROVIDED IT IS RATED AT LEAST 30 AMPS @ 250 VOLTS WITH GROUNDING-TYPE ATTACHMENT PLUG AND GROUNDING TYPE CONNECTOR (LOAD FITTING)

FOR MODEL 2OACH6012 AN EXTENSION CORD CAN BE USED PROVIDED IT IS RATED AT LEAST 50 AMPS @ 250 VOLTS WITH GROUNDING-TYPE ATTACHMENT PLUG AND GROUNDING TYPE CONNECTOR (LOAD FITTING)

FOR MODELS 2OACH3632 AND 2OACH6032 AN EXTENSION CORD MAY BE USED PROVIDED IT IS RATED AT LEAST 30 AMPS @ 250 VOLTS, 3 PHASE

FOR MODELS 2OACH3634 AND 2OACH6034 AN EXTENSION CORD CAN BE USED PROVIDED IT IS RATED AT LEAST 20 AMPS @ 600 VOLTS, 3 PHASE

SPECIAL NOTICE—THREE PHASE OPERATION

Models 2OACH3632, 2OACH3634, 2OACH6032 and 2OACH6034

All three-phase CONVERTIBLEAIRE models are equipped with a three-phase monitor for added compressor protection. The phase monitor, located in the control box, has multi-color LED that reports status. The monitor protects the compressor from reverse operation, phase loss and low voltage situations. Further description of the three-phase monitor is located in the electrical section of the manual.

NOTICE - DO NOT OPERATE ANY THREE-PHASE UNIT BY BY-PASSING THE MONITOR, THIS WILL VOID THE WARRANTY

CONDENSATE RESERVOIR TANK

For Models 2OACH12, -18, -24 -36, a 5-gallon polyethylene tank is provided standard, to collect condensate. The tank is located in the lower, front section of the unit. A high water level cut-out switch is used to stop the compressor and condenser fan automatically when the tank's pre-set water level has been reached. The evaporator fan will continue to run, circulating air. The control display will read "CON"

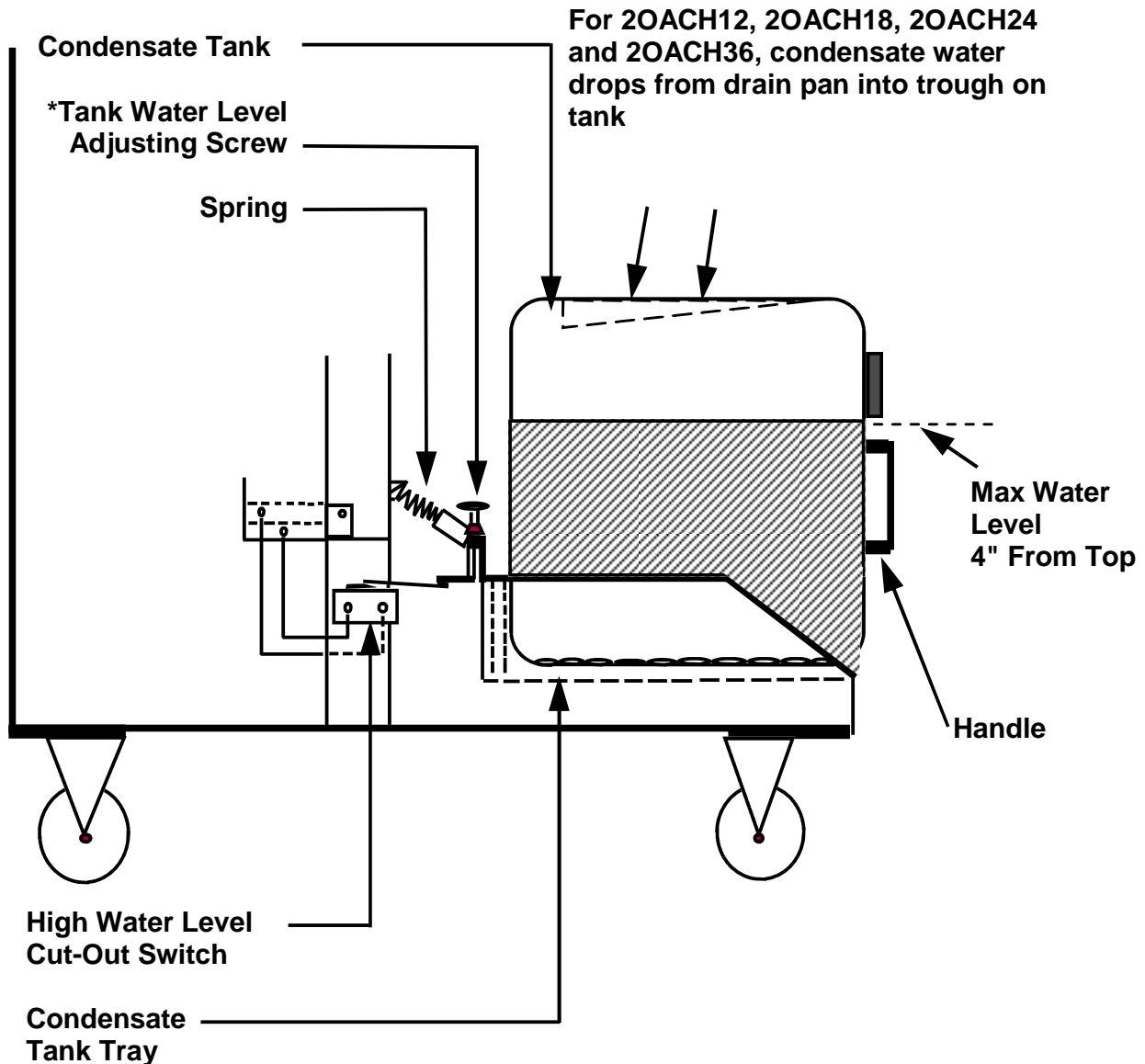

TANK LEVEL ADJUSTMENT INSTRUCTIONS

An adjustment screw is provided to vary the cut-off of the tank full switch. If a lighter (less weight) level of water is desired, turn the adjusting screw clockwise. Do not exceed 6 full turns counter-clockwise.

CAUTION, TURN UNIT OFF: **BEFORE ADJUSTING SET SCREW**
BEFORE REMOVING TANK TO EMPTY CONDENSATE

Turn screw clockwise to lower water level. Less water makes tank lighter and easier to remove.

NOTE: Max. and Min. water levels shown are those at which the unit will shutdown and not restart until the condensate tank has been drained.

ACCESSORIES

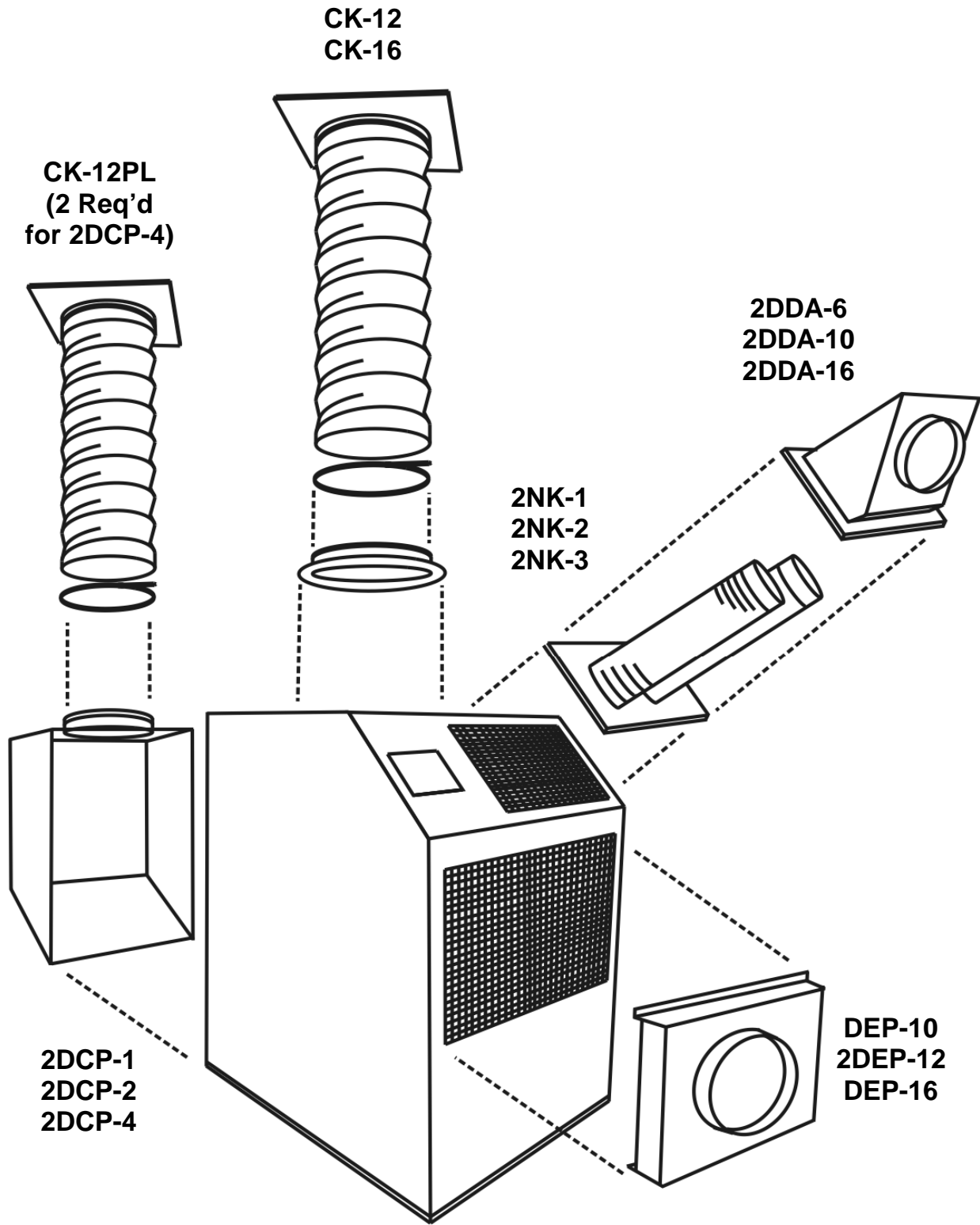

20ACH UNIT

2OACH – CONVERTIBLEAIRE ACCESSORIES

NOZZLE KIT

2NK-1	(2 X 4-Inch)	2OACH12
2NK-2	(2 X 6-Inch)	2OACH18, 24
2NK-3	(2 X 8-Inch)	2OACH36, 60



EVAPORATOR RETURN AIR PLENUM

DEP-10	(10-Inch Round)	2OACH12
2DEP-12	(12-Inch Round)	2OACH18, 24
DEP-16	(16-Inch Round)	2OACH36, 60

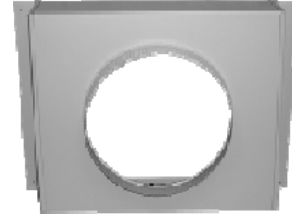

DISCHARGE DUCT ADAPTER

2DDA-6	(6-Inch Round)	2OACH12
2DDA-10	(10-Inch Round)	2OACH18, 24
2DDA-16	(16-Inch Round)	2OACH36, 60

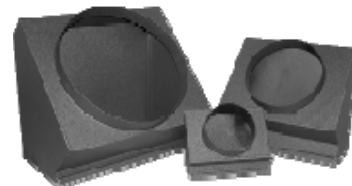

CONDENSATE PUMP KIT *

2DPC-1	115V Models
2DPC-2	230V Models

* Not Required for 2OACH60's



CEILING PANEL KIT

CK-12	2OACH12, 18, 24
CK-16	2OACH36, 60
CK-12PL	CK-12 without Duct Flange
CKP-12	2 X 2 Ceiling Panel w/12-Inch Dia. Flange
CKP-16	2 X 2 Ceiling Panel w/16-Inch Dia. Flange



DUCT FLANGE

DF-12	12-Inch Duct Flange
DF-16	16-Inch Duct Flange



CONDENSER RETURN AIR PLENUM

2DPC-1	2OACH12
2DCP-2	2OACH18, 24
2DCP-4	2OACH36, 60

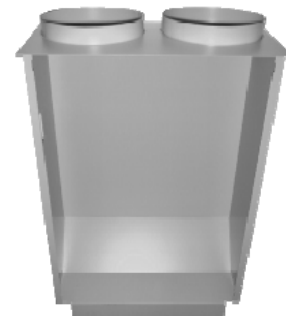

ACCESSORIES

CEILING PANEL DUCT KIT, CK-12, CK-16

A ceiling panel kit is available for discharging the condenser air above a drop ceiling.. The ceiling panel duct kits are furnished with a white vinyl coated flexible duct that allows for convenient installation. A 2ft X 2ft ceiling duct- panel is included to replace a 2ft X 2ft drop-ceiling panel where the connection is desired.

The CK-12 is available for all 2OACH-models except the 5-ton. The ceiling panel kit consists of 8 feet of flexible duct, a 2' X 2' lay in ceiling panel and a 12 inch duct flange that attaches to the condenser air discharge opening on the top of the unit. The CK-16 (for 5-ton units) consists of a ceiling duct-panel, and a 16 inch flexible duct.

Note—Drop ceiling spaces should be vented or large enough to handle the warm condenser air. Check local codes to assure compliance.

If longer runs of duct are required, table below lists maximum duct run with no 90° elbows. For every 90° elbow, subtract 6 feet from the run.

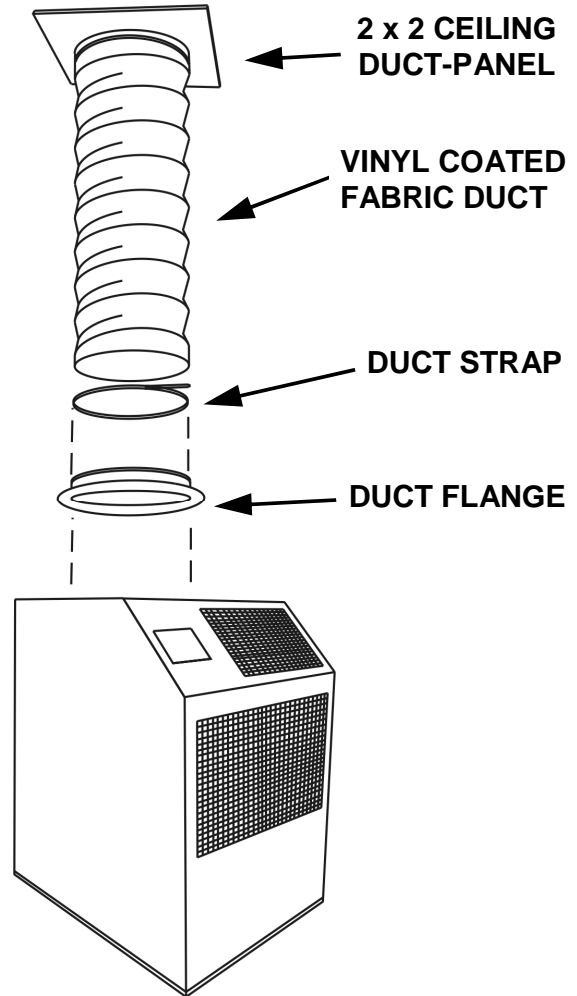

Ceiling Kit Model	Flexible Duct Diameter X Length	Fits 2OACH12	Fits 2OACH18	Fits 2OACH24	Fits 2OACH36	Fits 2OACH60
CK-12	12 inch X 8 feet	✓	✓	✓	No	No
CK-16	16 Inch X 8 feet	No	No	No	✓	✓
Maximum Equivalent Feet (approx) (ESP)		25 (.20)	50 (.25)	50 (.25)	50 (.25)	100 (.50)

DUCT FLANGE (DF-12, DF-16)

The optional duct flange allows for round flexible ducting to be attached to the CONVERTIBLEAIRE condenser discharge. DF-12 (12-inch diameter) fits all units except the 5 ton. The DF-16 (16 inch diameter) fits only the 5 ton Model 2OACH60.



DUCT FLANGE

NOTE: 2OACH36 and 2OACH60 units come with duct flanges installed.

ACCESSORIES

DISCHARGE AIR NOZZLE KIT ASSEMBLY (2NK)

The optional discharge nozzle kits are used to direct the conditioned air to a specific target area. By concentrating the airflow, the nozzles increase the air velocity towards production lines to cool personnel or equipment. In server rooms, the nozzles can be used to induce airflow through the rack to remove the hot air from the area of the equipment.

2NK-1 for model 2OACH12, with (2) 4-inch diameter nozzles with an approximate compressed length of 15 inches. The approximate extended length is 21 inches.

2NK-2 for models 2OACH18 and 2OACH24 with (2) 6-inch diameter nozzles with an approximate compressed length of 22 inches. The approximate extended length is 32 inches.

2NK-3 for 2OACH36 and 2OACH60, with (2) 8-inch diameter nozzles with an approximate compressed length of 20 inches. The extended length is approximately 29 inches.

The nozzle kits come pre-assembled with the nozzles secured to a mounting plate, and with edge guards. By removing the CONVERTIBLEAIRE discharge grill, one can insert the nozzle kit into the opening without the use of tools.



Nozzle Kits

CONDENSATE PUMP KIT: 2DPC-1 and 2DPC-2

A plug-in condensate pump kit is available for applications where emptying the 5 gallon condensate tank is not desired. The pump kit consists of a condensate pump with mounting hardware and electrical connections, along with the tubing required for the drain and discharge of the condensate water.



The condensate pump provides for the automatic removal of condensate water during the cooling process. The pump is capable of pumping against a 20 foot head, allowing for the routing of the drain line above the drop-ceiling to a nearby drain. The pump is controlled by an internal float-switch which turns the pump on and off automatically. The pump is also equipped with a condensate over-flow safety switch, that will shut down the CONVERTIBLEAIRE compressor when the pump is not working

PARTS LIST

- (1) Condensate Pump with mounting hardware
- (1) 3/8-inch drain hose, 25 ft
- (2) Mounting screws
- (1) Drain hose — black corrugated
- (2) Hose clamps

<u>Kit</u>	<u>Voltage</u>
2DPC-1	115V
2DPC-2	208-230V

ACCESSORIES

CONDENSER RETURN AIR PLENUM, 2DCP

Condenser return air plenums are available for installations where it is required to duct air to the inlet of the condenser. The plenum easily attaches with one screw to the back of the unit, and is provided with flange(s) for connecting 12-inch flexible ducting. A condenser return air plenums can substantially reduce air noise and allows the unit to operate without drawing condenser air from the conditioned space. Refer to the table below for configuration and application information.

NOTE — When installing the condenser return air plenum with the ceiling panel kits, allow for a minimum separation distance of 2 feet between the unit discharge duct and the return air duct(s). It is also recommended to direct the condenser discharge air away from the condenser return air ducts.



2DPC-1, 2DCP-2

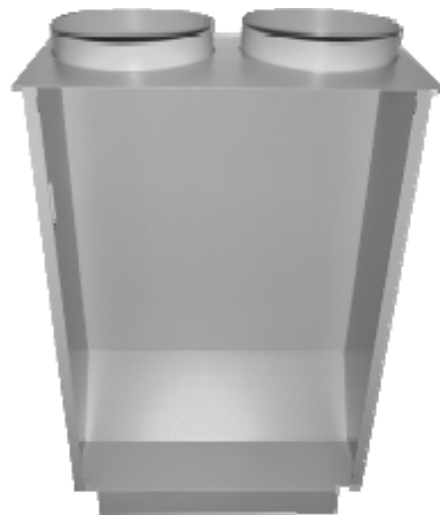

2DCP-4

To estimate the “equivalent feet” of condenser duct, add the length of the condenser intake duct run and the length of the condenser discharge duct run, and add 6 equivalent feet per bend in the duct. Make sure that you do not exceed the rated E.S.P. to avoid shut down due to the high pressure cut-out

Plenum Kit	Duct Flange	2OACH12	2OACH18	2OACH24	2OACH36	2OACH60
2DCP-1	12-inch	✓				
2DCP-2	12-inch		✓	✓		
2DCP-4	(2) 12-Inch				✓	✓
Maximum Approximate Equivalent Feet		25	50	50	50	100
Estimated External Static Pressure		(.20)	(.25)	(.25)	(.25)	(.50)

ACCESSORIES

EVAPORATOR RETURN AIR PLENUM, 2DEP

Evaporator return air plenums are available for installations where it is required to duct air to the inlet of the evaporator. The evaporator return air plenums allow the user to connect round duct (flexible or rigid) to the return air intake to reduce air noise and increase the number of options for solving difficult cooling problems. The plenum attaches to the front of the unit, replacing the return air grill. Refer to the table below for configuration and application information

DEP-10 for 2OACH12 transitions the return air opening to 10-inch round duct.

2DEP-12 for 2OACH18 & 2OACH24 transitions the return opening to a 12-inch round duct.

DEP-16 for 2OACH36, 60 transitions the return opening to a 16-inch round duct.

NOTE—When a evaporator return air plenum is installed, it is recommended to set the evaporator blower speed to high, to avoid evaporator freeze-up.

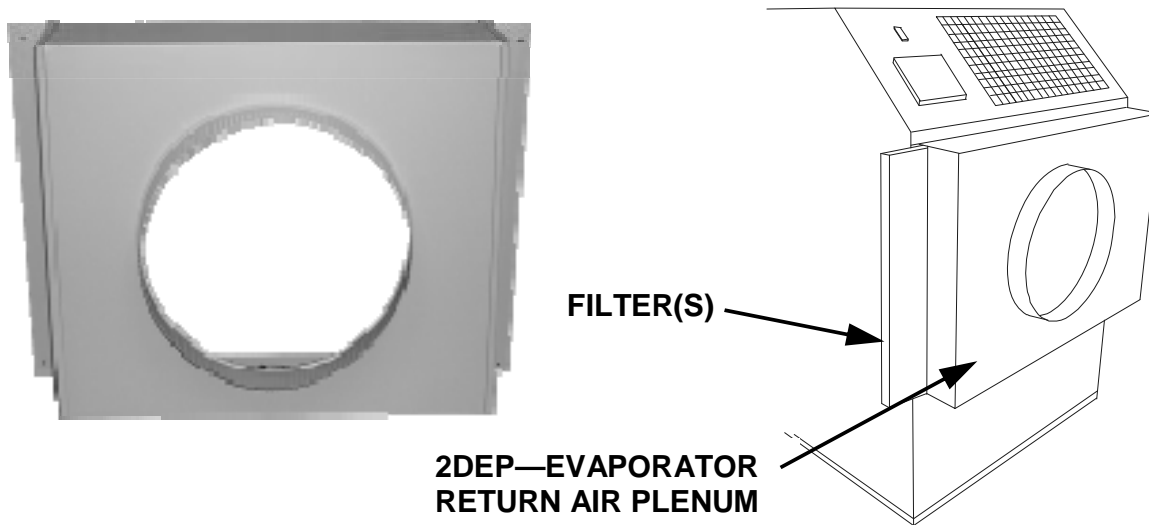

Plenum Kit Duct/Flange	2OACH12	2OACH18	2OACH24	2OACH36	2OACH60	FILTERS
DEP-10 10 inch	✓					(1) 10"X20"X1"
2DEP-12 12 inch		✓	✓			(1) 15"X25"X1"
DEP-16 16 inch				✓	✓	(1) 12"X30"X1" (1)15"X30"X1"
Maximum Equivalent Feet	25	50	50	50	100	
Est. External Static Pressure	(.20)	(.25)	(.25)	(.25)	(.50)	

ACCESSORIES

Discharge Duct Adapter, 2DDA

Discharge duct adapters are available for applications where ducted evaporator discharge is required. The adapters can be easily installed on the unit without fasteners, and be installed for either vertical or horizontal ducting. The standard discharge grille is removed and the 2DDA is attached in the grill opening.

2DDA-6 for 2OACH12, converts the evaporator discharge to a 6-inch diameter round duct.

2DDA-10 for 2OACH18 and 2OACH24, converts the evaporator to a 10-inch diameter round duct.

2DDA-16 for 2OACH36 AND 2OACH60 models, converts the evaporator discharge to a 16-inch round duct.

When used in conjunction with the evaporator return air plenum, DEP, the unit can provide closed-loop cooling to and from a given space without the influence of any outside air.

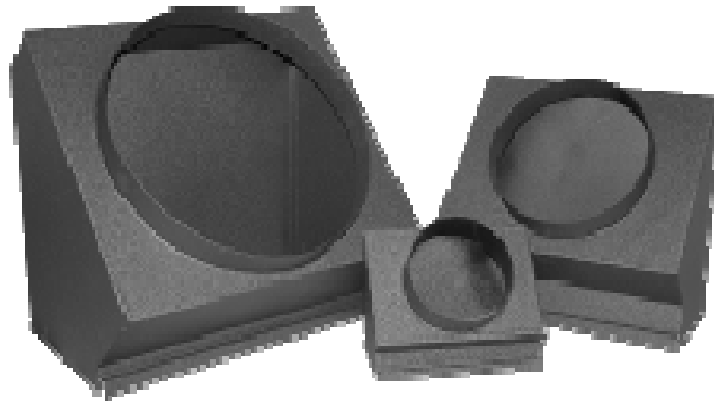

Adapter Model	Round Duct Size	2OACH12	2OACH18	2OACH24	2OACH36	2OACH60
2DDA-6	6-inch	✓				
2DDA-10	10-inch		✓	✓		
2DDA-16	16-inch				✓	✓
Maximum Approx Equivalent Feet		25	50	50	50	100
Maximum E.S.P		.15	.25	.25	.25	.50

INSTALLATION INSTRUCTIONS

RECEIVING—INSPECTION:

Upon receiving your CONVERTIBLEAIRE unit, inspect the packaging for any damage. All units are shipped on a skid, and packaged in a triple-wall carton for added protection. In shipment, some wear may occur on the packaging. If the packaging is heavily damaged or broken, file a claim with the freight company immediately. Carefully unpack the unit and remove all wrapping materials. Save all documentation and fill out the Warranty Card and mail it to Oceanaire.

BEFORE INSTALLING

Check the air conditioner/spot cooler for any damage. All Oceanaire products are thoroughly inspected at the factory and carefully packaged. If any damage is evident, file a claim with the delivering carrier immediately.

ELECTRICAL REQUIREMENTS

Check the nameplate located on the back of the unit to make certain that the proper power is available for the unit. Refer to "Specifications" section for voltage and amperage requirements. For proper NEMA receptacles, refer to "Electrical service plug configuration". When using extension cords, use the properly sized cord, and check cord voltage to the unit.

TIME DELAY FUSES/CIRCUIT BREAKERS ARE RECOMMENDED

**WARNING—OPERATING THE UNIT ON
IMPROPER VOLTAGE WILL VOID THE
WARRANTY**

ACCESSORIES

Verify that all accessories are correct for the model, and that they installed in accordance with all instructions.

START-UP

Install the unit in accordance with all local and state building codes, and install all accessories. Allow for a clearance around the unit for future maintenance and/or service. Level unit and lock casters, when available. Connect power and test the LCDI on the power cord (if available). Power up unit, via thermostat and check for proper operation. Refer to Thermostat Operation for more details.

Deluxe Electronic Controller

The CONVERTIBLEAIRE controller is equipped with many features for a more precise level of cooling and operation. Additionally, the controller can be removed from the unit and installed for remote operation, if desired—accessory parts may be required.

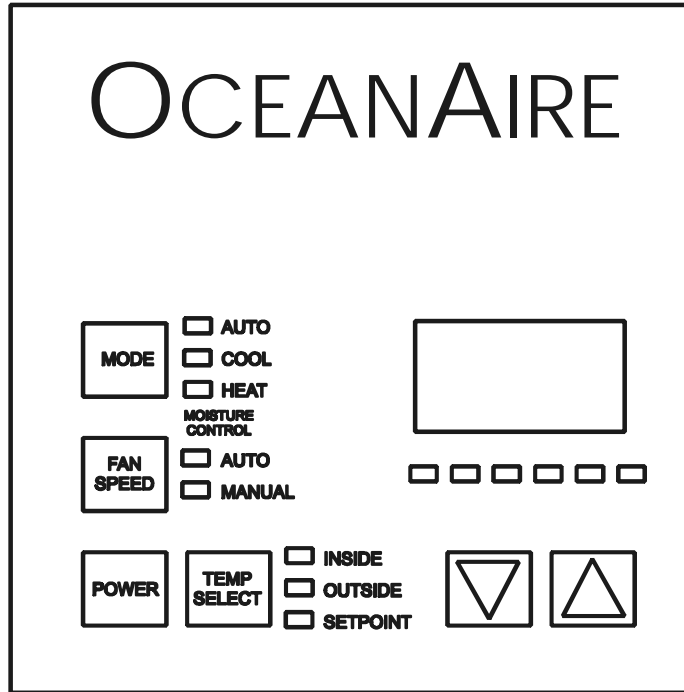

OCEANAIRE DELUXE ELECTRONIC CONTROLLER

When power is connected, the controller will display “888” momentarily, and will then go blank. Press the POWER button, then press the TEMP SELECT button until the SET POINT is displayed. Adjust the SET POINT to the desired temperature, and the unit will heat/cool as required.

The systems controls temperature within +/- 2°

POWER—Turns the unit on/off when power is supplied

MODE - Selects the mode of operation from AUTO to Cool, to Heat, or to Moisture Control.

AUTO - The controller will heat or cool as required. HEAT or COOL will display accordingly. A 4° differential is needed to change between cooling and heating modes.

COOL - The system will operate in cooling mode, only.

HEAT - The system will operate in heating mode, only.

MOISTURE CONTROL - The system operates in the cooling mode to reduce humidity within the conditioned space.

Every 4 hours, the fan is started, circulating the air, and the air temperature is recorded by the controller. The cooling cycle is started for one hour, or until the room temperature drops 2°, which ever comes first. This cycle repeats every four hours.

FAN SPEED—The operator can select between AUTO and MANUAL fan speed control. Pressing the FAN SPEED button, will switch speed from AUTO to MANUAL. In MANUAL mode, pressing the FAN SPEED button will change fan speed from low to high. In AUTO the fan speed is controlled automatically. In cooling mode, the controller automatically adjusts the fan speed to high, and as the inside temperature approaches the set point, the fan speed will reduce. In heat mode, the fan speed goes from low to high as the temperature approaches the set point

TEMP SELECT—Allows the operator to view the controller temperatures; INSIDE = return air temperature, OUTSIDE = supply air temperature, SET POINT can be seen and adjusted, by pressing ▲ or ▼.

CONTROLLER PROGRAMMING MENU

- 1) Make sure the unit has power.
- 2) Pushing the POWER button, turn the unit “OFF”.
- 3) Press the following buttons in sequence “S-U-D-S”:
- 4) The display will begin flashing P1 and a number.

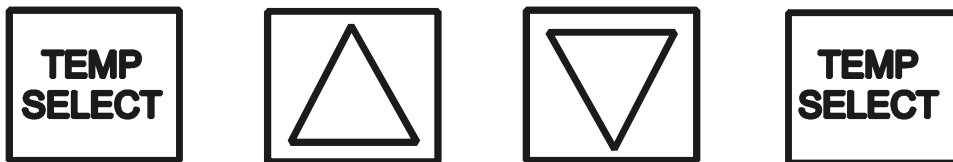

If there is no display, repeat the sequence, making sure the unit has power, but is turned OFF.

- 5) To adjust any program parameter, press the ARROW UP ▲ or ARROW DOWN ▼ button until the desired value is displayed.
- 6) Use the “MODE” button to scroll through the programmable parameters P1 through P16.
- 7) If no buttons are pushed, the display will then return to the “OFF” position after about 50 seconds.

PROGRAMMING PARAMETERS

P1—High Fan Speed Limit Setting. 56 - 85
P2—Low Fan Speed Limit Setting, 30 - 55
P4—Temperature Sensor Calibration, +/- 10°
P10— Temperature Display, °F or °C
P13—Supply Fan Operation, Cycling or Continuous
P15—Fan Motor Type Setting, PSC or Shaded Pole

P1, P2 - To adjust fan speed settings, P1 represents the high fan speed parameter, while P2 represents the low fan speed parameter. When using nozzle kits, discharge duct adapters and evaporator plenums, setting P1 to 85 will help to avoid freeze ups.

P4 - Adjust the P4 setting to match the actual INSIDE room temperature, if needed.

P10 - Use this parameter to display temperatures in the desired units.

P13 - To cycle the evaporator fan with the compressor, access code P-13. Press the up or down button to switch to “CYC”, which means cycle the fan with the compressor. The factory default setting is “CON”, which means continuous fan operation.

P15 - Fan Motors are PSC type, SC - should be selected.

- 8) Press POWER—you should see a code A (followed by numbers)

Press POWER and the unit will start at the new settings

CONVERTIBLEAIRE PROGRAM PARAMETERS

MODEL	CODE SETTINGS
2OACH12	P1 = 85, P2 = 35
2OACH18	P1 = 80, P2 = 50
2OACH24	P1 = 70, P2 = 50
2OACH36	P1 = 85, P2 = 40
2OACH60	P1 = 85, P2 = 45

NOTICE

Program Parameters are NOT controller default values.
They are Oceanaire Factory Settings

DISPLAY FAULTS

LAC..... Low AC line power

AAA..... Failed Air Sensor (unit will not run)

CON..... Empty Condensate Bucket—Units with a bucket
Condensate Pump Over-Flow Alarm—Units with pump
High Pressure Cut-Out—Low condenser water supply
correct problem, and re-set unit at HP RESET

TO CHECK THE NUMBER OF HOURS ON THE UNIT

- 1) Disconnect unit power, and reconnect unit power.
- 2) When “888” appears in display, push and release the arrow down button



- 3) The first set of numbers displayed reads thousands of hours:
02 = 2000, 04 = 4000 hours, 00 means less than 1000 hours.
- 4) The second set of numbers read hours directly:
58 = 58 hours. 742 = 742 hours.
- 6) Add the 2 number sets together to get total hours.
03 and 486 = 3486 hours. 01 and 59 = 1059 hours.

TOTAL HOURS REPRESENTS COMPRESSOR “RUN” TIME

REPLACEMENT PROCEDURE FOR PARTS

IT IS RECOMMENDED THAT ALL OCEANAIRE UNITS BE SERVICED BY A LICENSED TECHNICIAN

WARNING—TO AVOID INJURY, DISCONNECT UNIT POWER PRIOR TO SERVICING

A. FAN MOTORS

1. Remove cabinet's left-side panel (when looking at the front of the unit).
2. Evaporator fan motor—disconnect evaporator motor wires from evaporator fan contactor and fan speed rocker switch. Condenser fan motor—disconnect condenser motor wires from condenser fan contactor.
3. ***For all model sizes 12, 18 and 36***, remove the screws securing motors and inlet-ring to blower housings (all screws are external and visible), and remove blower wheel-motor assembly. Remove the blower wheel set screw and disassemble the blower wheel from the motor shaft and remove the motor.
For models size 60—loosen blower wheel shaft set screw, and remove the screws securing the motor mount to the blower housing and remove motor and mount. Remove the motor from the motor mount.
4. Install the new motor, reversing the removal procedure.

B. ELECTRONIC CONTROLLER (2 PARTS)

1. To remove the Heat/Cool display, remove the cabinet's left-side panel (from front). Locate the two nuts securing the display to the front panel. Unplug the display cable and remove display. Install new display and secure. Plug in display cable.
2. To remove the Power Module, remove the rear control box cover. Disconnect wires, and remove power module. Install new power module, and re-wire in accordance with the wiring diagram.

5. CONDENSATE PUMP (ON ALL 5-TON UNITS OR ON UNITS WHERE THE CONDENSATE PUMP KIT HAS BEEN INSTALLED)

1. Remove side panel.
2. Remove brackets securing condensate pump in base pan, or condensate tank tray pan
3. Disconnect pump wire leads at Molex connectors. Remove retainer clamp and tubing.
4. Replace pump, install by reversing procedure.

E. HIGH PRESSURE SAFETY SWITCH

1. Remove cabinets right side panel, or right rear side panel of Model 60.
2. Remove flare nut that secures capillary to the refrigeration system high pressure side. A Schrader valve is located in the discharge port, and allows removal without dumping the refrigerant charge.
3. Remove two screws that retain high pressure switch.
4. Disconnect wire leads from compressor contactor and condensate pump safety switch.
5. Install new High Pressure Control, reversing the procedure.

To gain access to compressor and compressor run capacitor, remove left hand side panel.

TROUBLESHOOTING GUIDE

The following steps and procedures are recommended for correcting the problems indicated. In the event that the problem can not be corrected, service may be required.

SERVICE SHOULD BE PERFORMED BY A QUALIFIED AIR CONDITIONING SERVICE TECHNICIAN

PROBLEM: UNIT DOES NOT POWER UP

CAUSE: Power interruption

REMEDY: Check LCDI (on models with LCDI), and reset LCDI. Check external power supply making sure that the disconnect is ON. Check for blown fuses or tripped circuit breakers. Reset or replace if needed.

CAUSE: Loose display cable

REMEDY: Re-seat display cable at display and power module.

CAUSE: Phase Monitor Fault (3-Phase Models)

REMEDY: Check Phase Monitor, and correct power problem>

PROBLEM: EVAPORATOR FAN RUNS BUT COMPRESSOR AND CONDENSER FAN DO NOT START

CAUSE: SET POINT — setting may be too high for cooling or too low for heating.

REMEDY: Make sure set-point is adjusted accordingly. You should see a red dot to the right of the temperature display indicating compressor ON.

Note—there is a time delay for the compressor

CAUSE: Loose Display Cable

REMEDY: Examine the control unit for loose wires. Tighten any loose connections.

CAUSE: Condition Alarm—"CON".

REMEDY: Check condensate tank and empty tank or check condensate pump and make sure pump is working properly and that there is no kink in the drain line from the pump.

CAUSE: High Pressure Cut-Out—"CON" Check High Pressure Cut-out Switch. Press Reset and clear away any obstructions to the condenser intake or condenser discharge.

CAUSE: Compressor contactor open or burned.

REMEDY: Replace contactor

CAUSE: Defective Power Module

REMEDY: Replace Power Module.

PREVENTIVE MAINTENANCE

AirBoss Spot Coolers are designed to last a long time and to give maximum performance and reliability with minimum maintenance. To prolong the life of the unit, regular maintenance must be performed as specified below:

BLOWER MOTORS

The motors on all units have permanently lubricated bearings. No oiling is necessary

FILTERS

A clogged filter will cause the unit to operate at greatly reduced efficiencies. We recommend that the filter be inspected on a regular bases every six weeks or more often depending on the environment. The evaporator filter is located behind the return air grille and can be easily removed and cleaned. The condenser filter is located in the lower backside of the unit. Remove by loosening one screw holding retaining clip and pull out. The filters must be washed periodically as needed by placing them in a dishwasher or soaking them in a solution of warm water and detergent for 10 minutes. Then rinsing them clean with hot water and shaking excess moisture from filter.

CONDENSATE PUMP

Condensate pumps come standard on all Size 60 models, and may be installed as options on size 12, 18, 24 and 36 models. When servicing pump follow these steps;

1. Make certain that the unit is disconnected from the power source before attempting to service or remove any component.
2. Be sure the floats move freely. Clean as necessary.
3. Remove the volute and check for obstructions. Clean as needed.
4. Clean the tank with warm water and mild soap when mineral deposits are visible.
5. Check the inlet and outlet piping. Clean as necessary. Be sure there are no kinks in the lines that would inhibit flow.

GENERAL

When necessary maintenance steps outlined above are followed, the air conditioner will provide long and reliable service. The refrigeration and electrical circuits of the system should only be serviced by a fully qualified service technician.

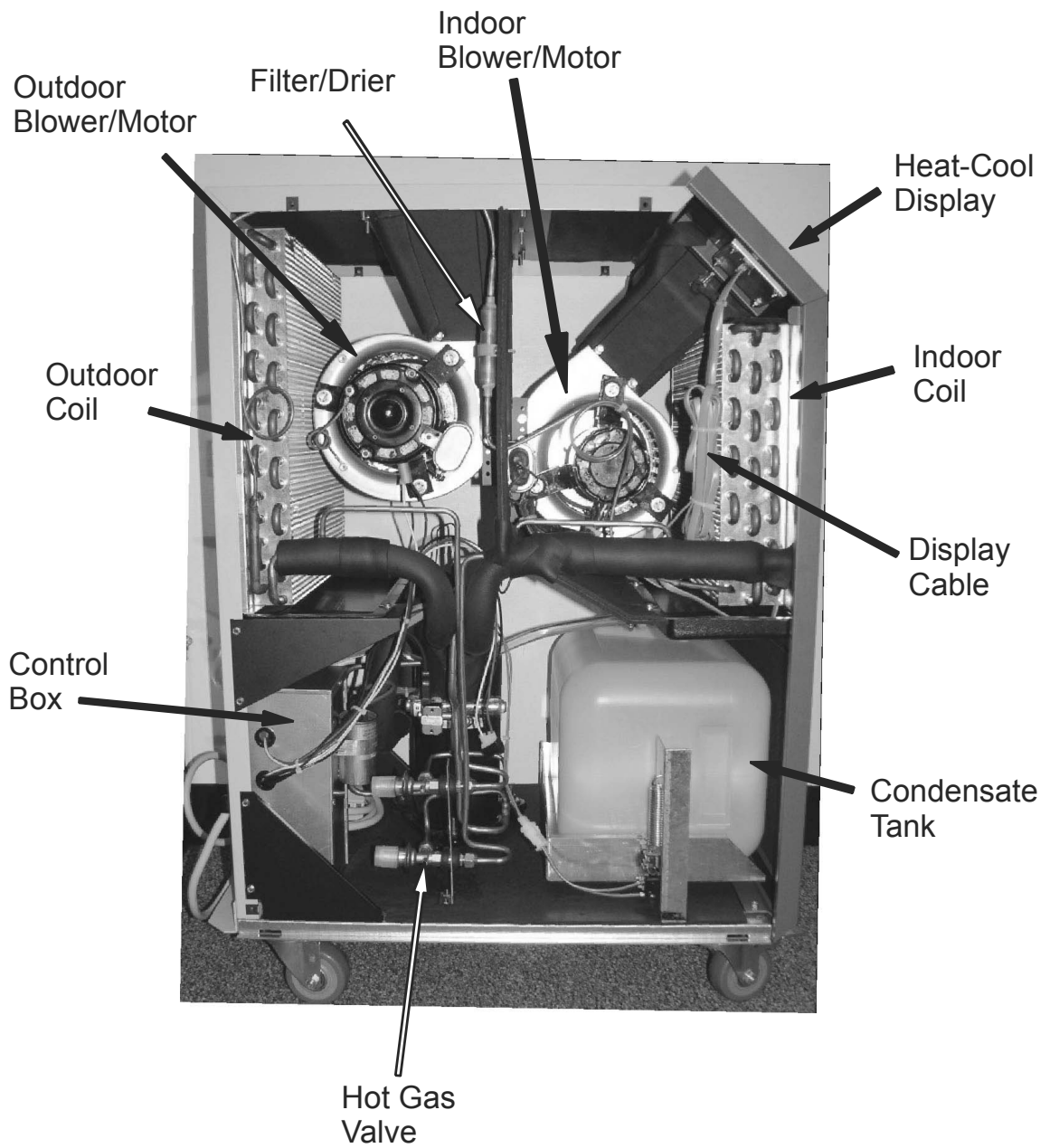

**20ACH12
INTERIOR VIEW**

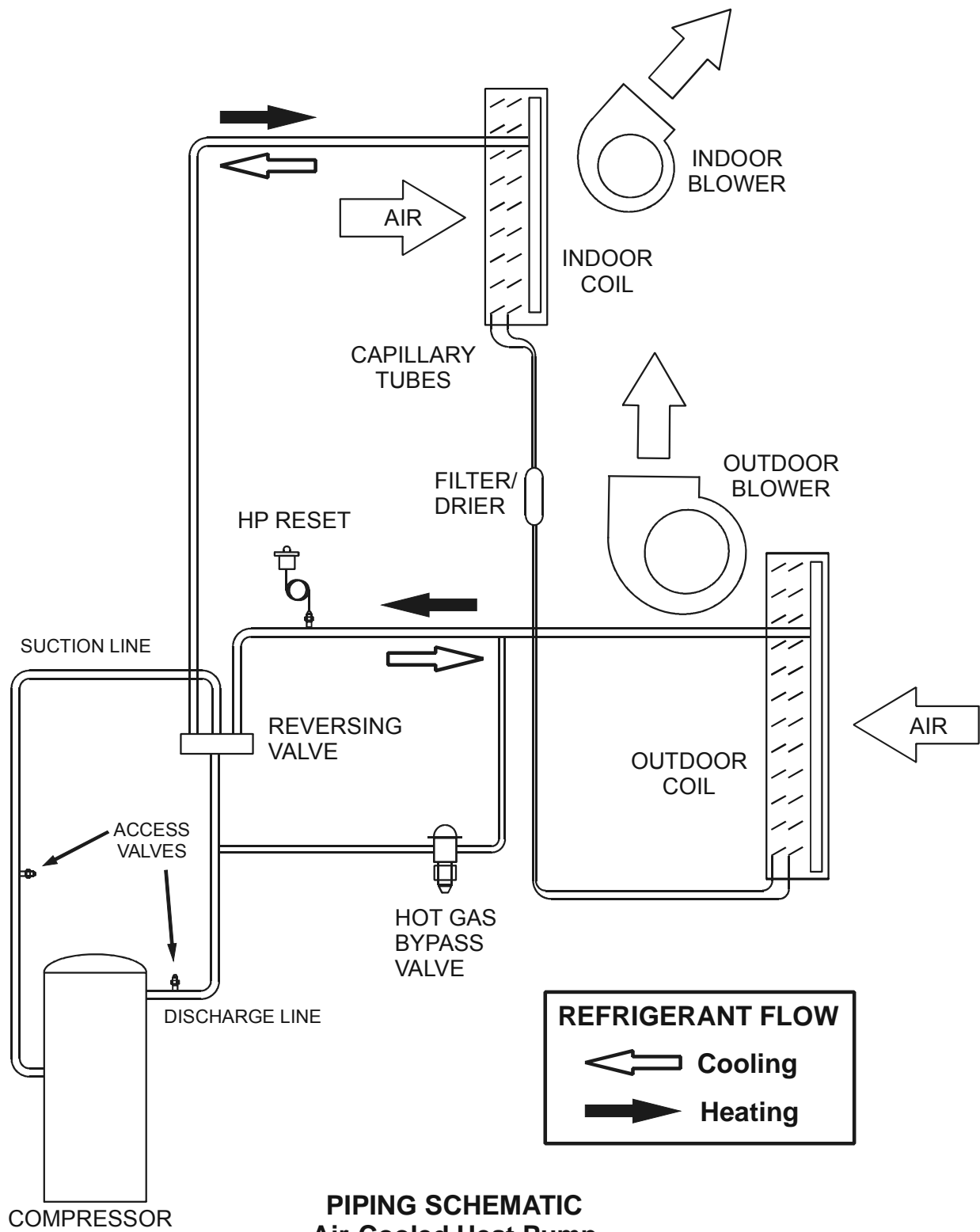

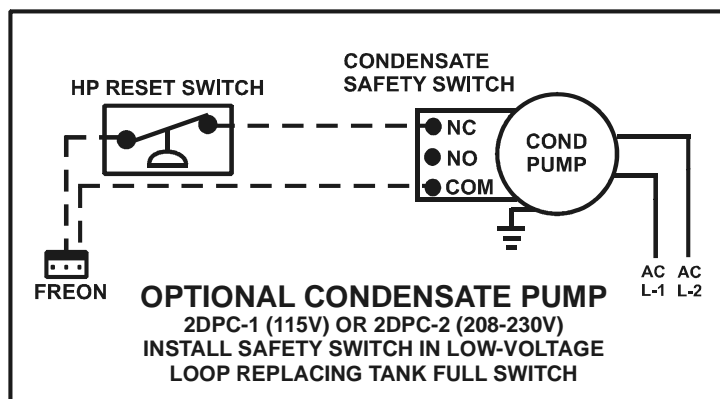
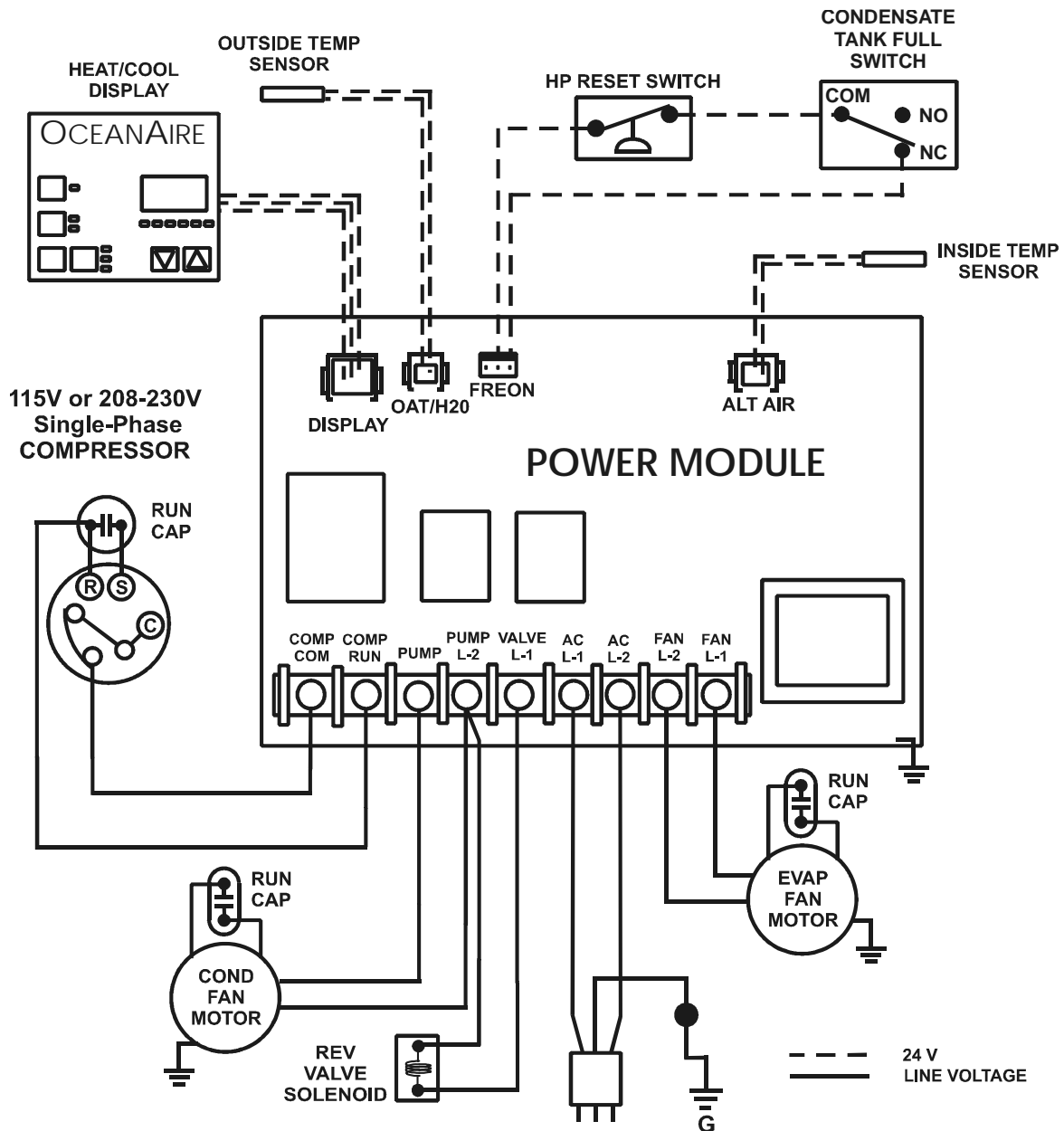

**AIR-COOLED HEAT PUMP
 MODELS 2OACH1211, 2OACH1811
 115 VOLT / SINGLE-PHASE
 2OACH2412
 208-230 VOLT / SINGLE-PHASE**

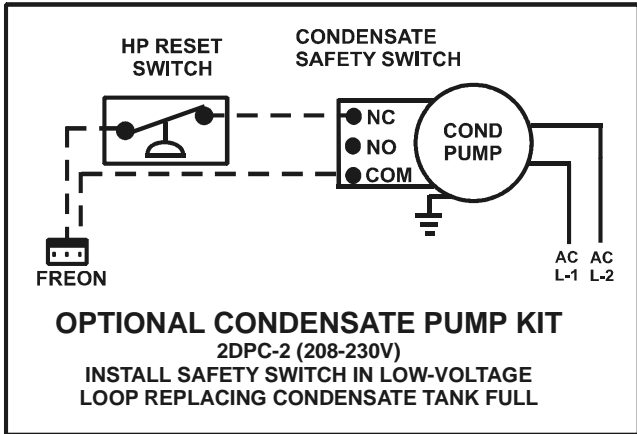
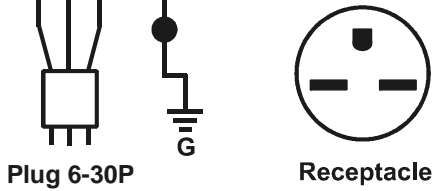
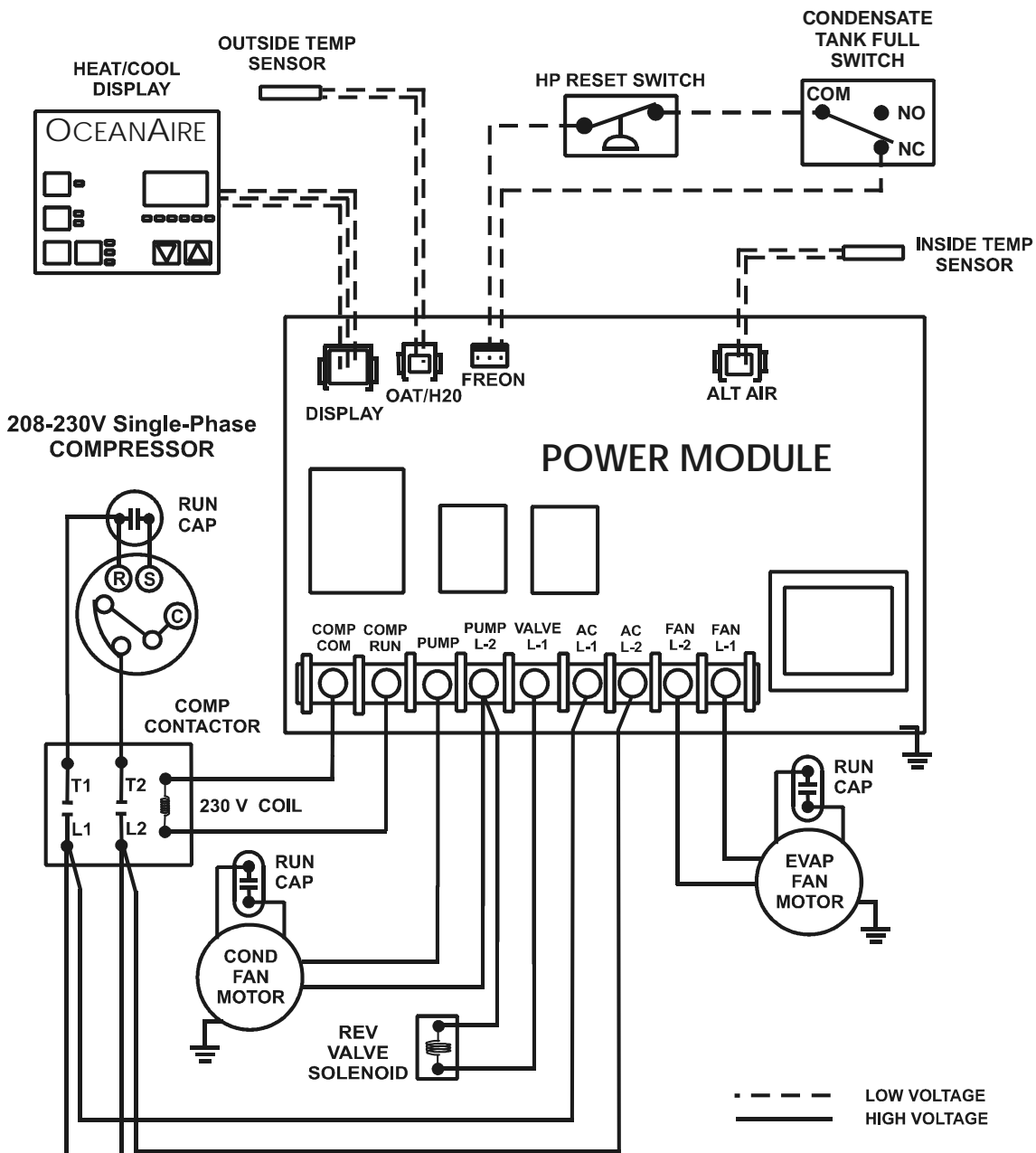

**AIR-COOLED HEAT PUMP
MODEL 2OACH3612
208-230 V/ SINGLE-PHASE**

OCEANAIRE

www.oceanair-inc.com

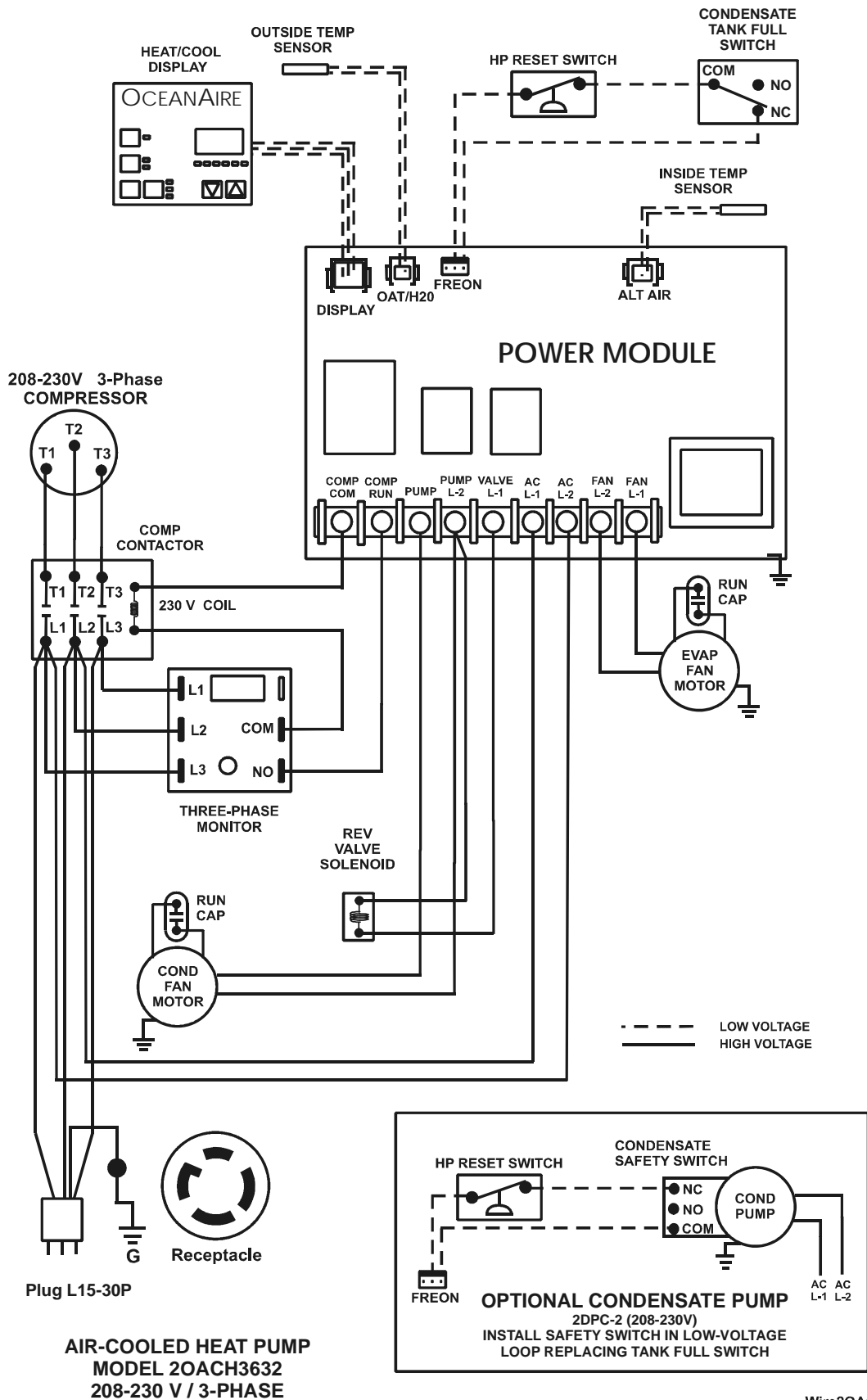

**AIR-COOLED HEAT PUMP
MODEL 20ACH3632
208-230 V / 3-PHASE**

VERIFY CORRECT COMPRESSOR ROTATION

Wire20ACH3632
052009

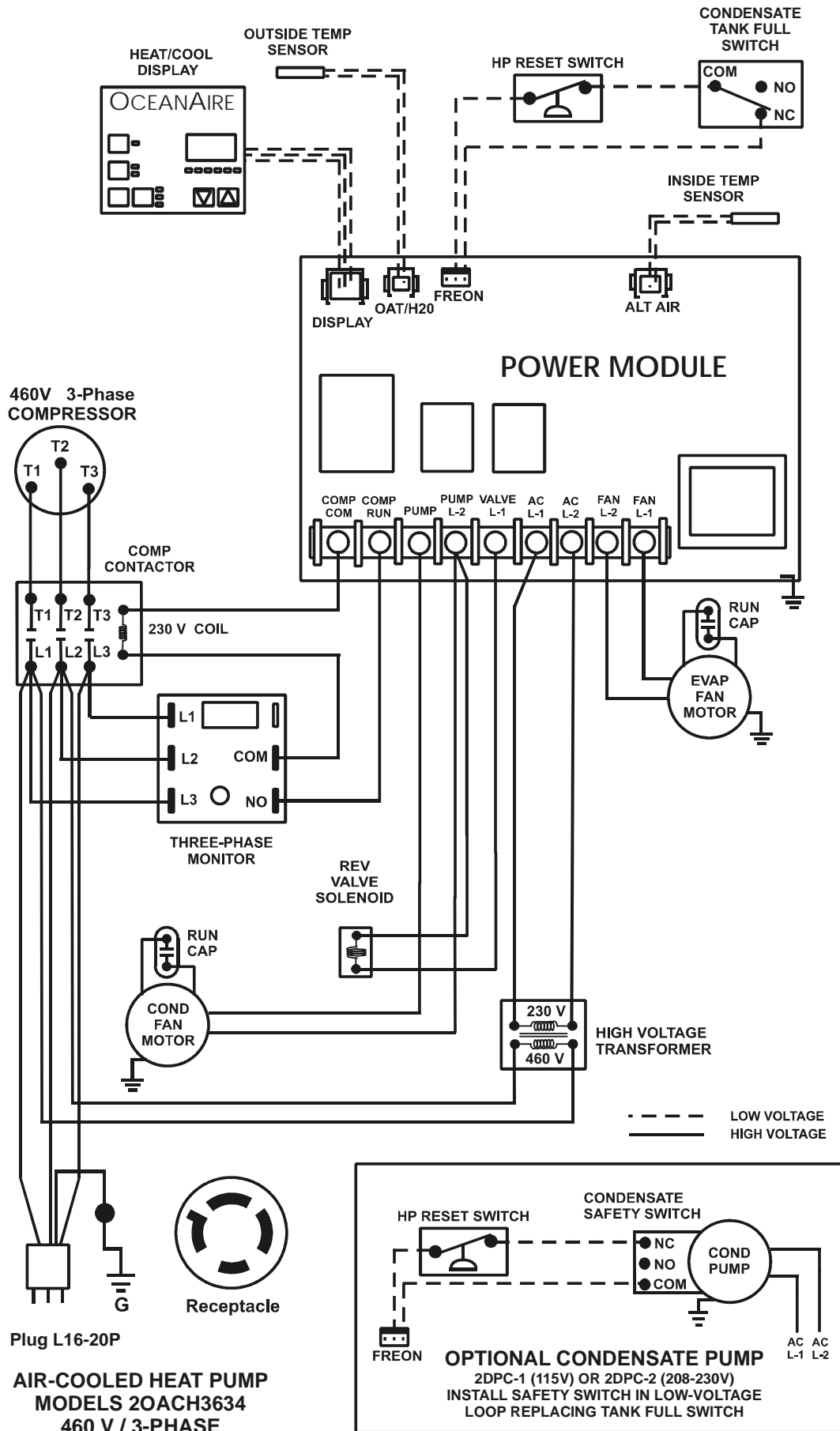

VERIFY CORRECT COMPRESSOR ROTATION

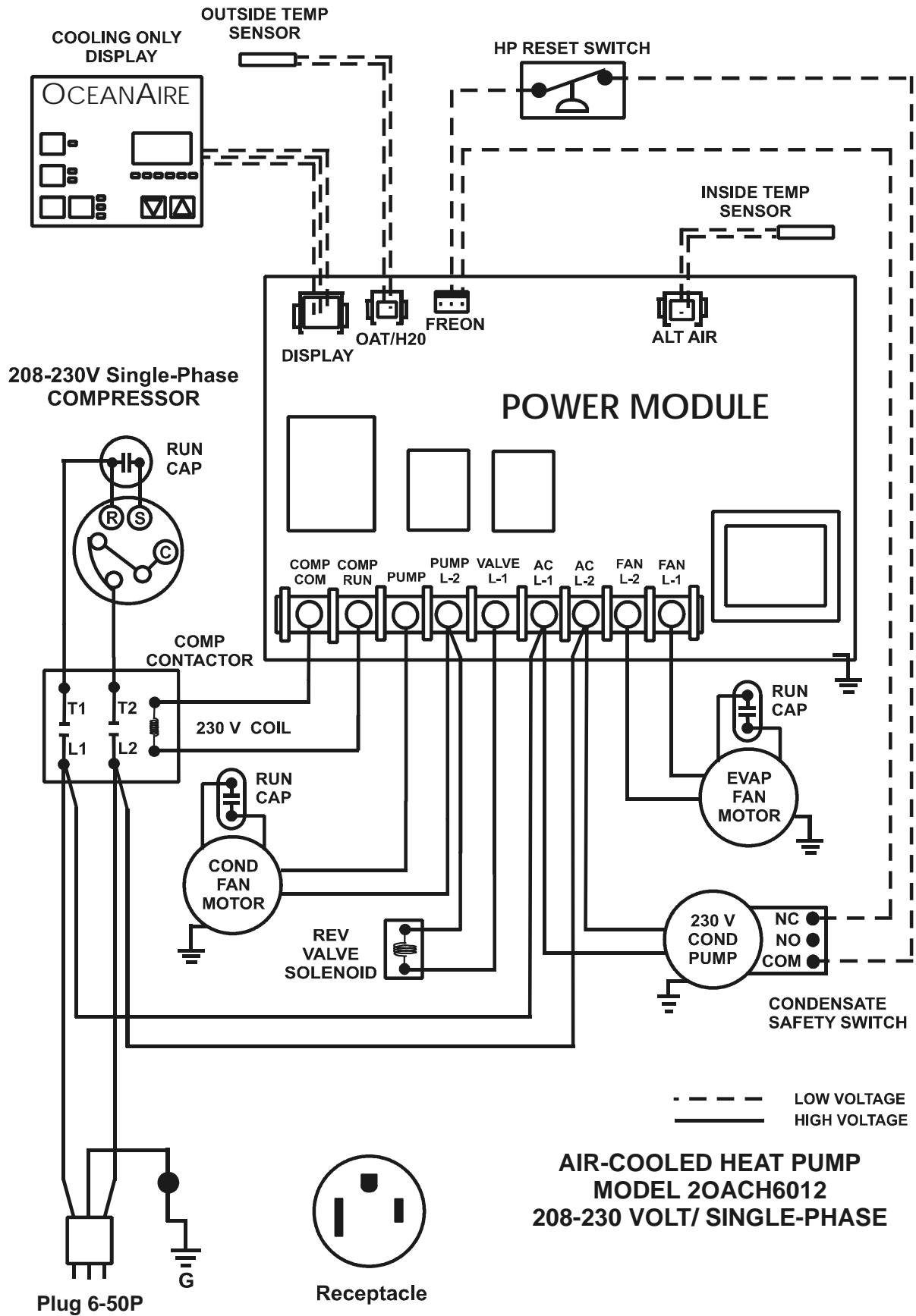

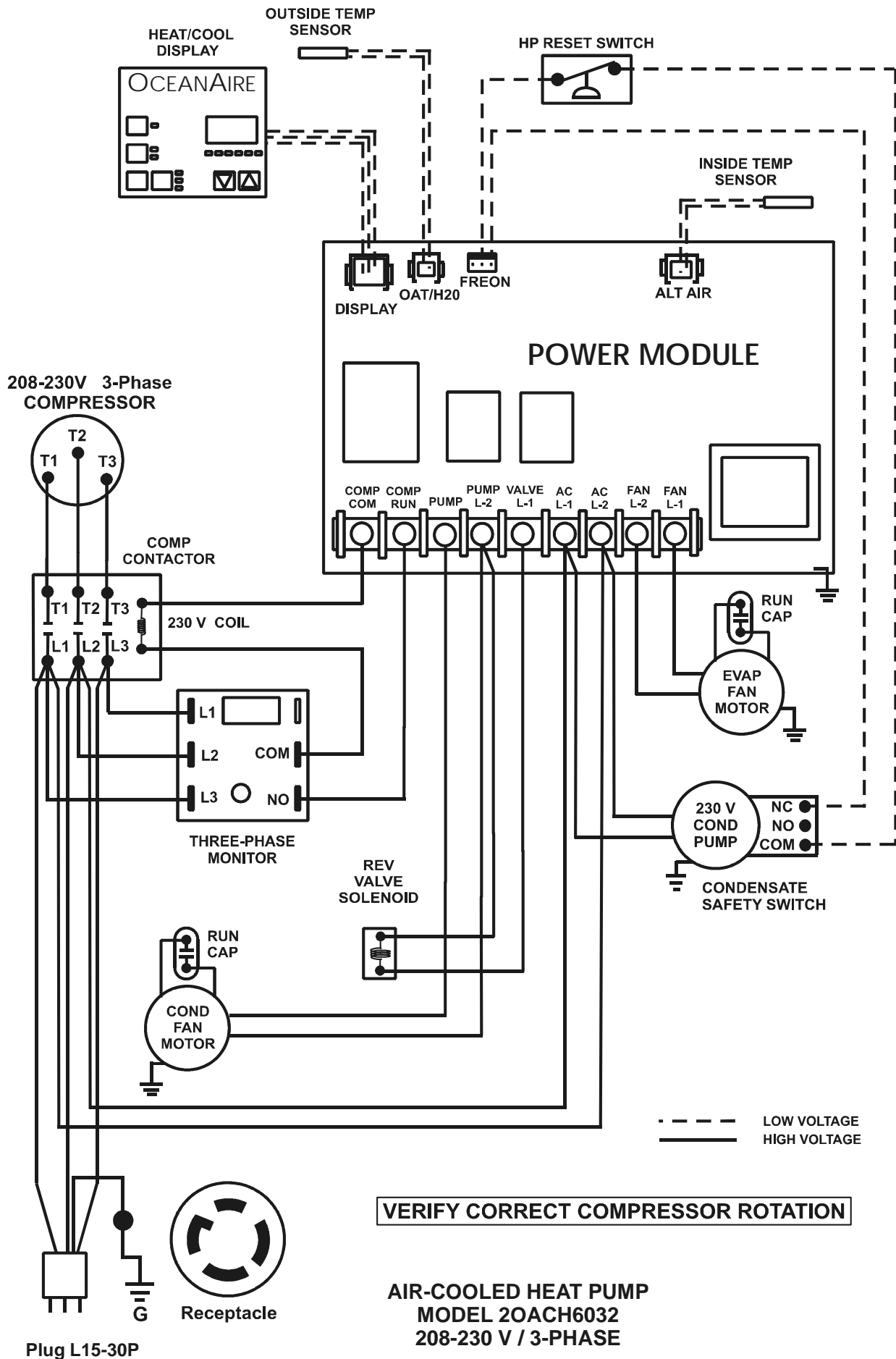

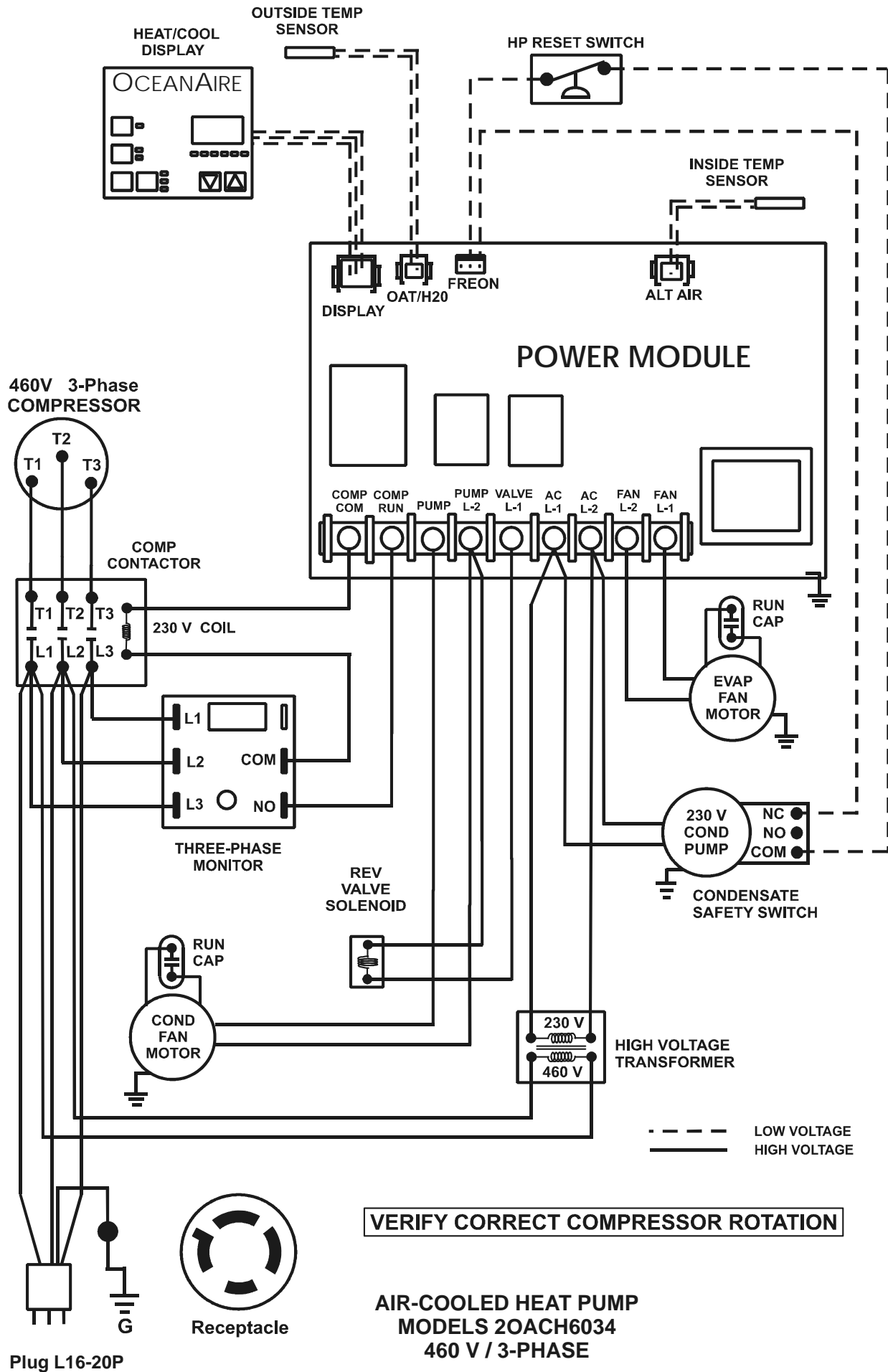

Three Phase Monitor

Three-Phase units can be equipped with monitors for compressor protection. The Oceanaire Three-phase Monitor safeguards the unit against incorrect compressor rotation, low-voltage and/or loss of power in any one of the power legs. The monitor is installed in the control box and is equipped with an LED for diagnosis of an improper electrical condition (see diagrams below). When power is connected, the compressor WILL NOT power up, until the monitor start delay has been timed out. If the compressor does not power up, an electrical condition may need to be addressed. Remove the control box cover and check the observe the LED on the phase monitor. The LED signals the following:

GREEN-BLINKING - Start delay, 120 sec.

GREEN - Proper Operation

RED/GREEN-BLINKING signals reverse phase rotation. Switch any two of the power leads for the unit, NOT THE MONITOR LEADS, and re-start.

RED-BLINKING signals improper voltage and/or phase loss. Correct the power problem, then re-start the unit.

In the event of a power interruption, the unit will re-set to a start-up condition. The Phase Monitor will not allow the compressor to start until power is corrected.

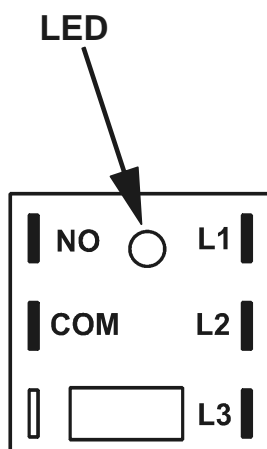

**THREE-PHASE
MONITOR**
230V, 025-045
460V, 025-046

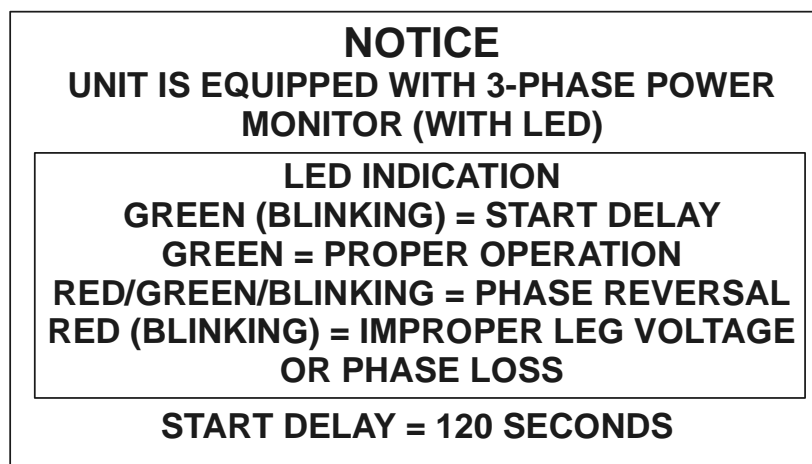

CONTROL BOX LABEL

MANUFACTURER'S LIMITED WARRANTY

The Manufacturer (OceanAire, Inc.) warrants to the original owner that the Product will be free from defects in material or workmanship for a period not to exceed one (1) year from date of installation. If upon examination by the Manufacturer the Product is shown to have a defect in material or workmanship, during the warranty period, the manufacturer will repair or replace, at its option, that part of the Product which is shown to be defective.

The Manufacturer further warrants that the product's compressor-motor will be free from defects in materials and workmanship for five (5) years from the date of installation. If upon examination by the Manufacturer, the Compressor-Motor is shown to have a defect in materials or workmanship during the warranty period, the Manufacturer will repair or replace, at its option, that compressor which is shown to be defective. Electrical parts (such as relays, overloads, capacitors, etc.) and the sealed refrigeration system (condenser and evaporator) are included in the one year limited warranty, but not with the five year limited warranty of the compressor. This limited warranty does not apply:

a) if the Product has been subjected to misuse or neglect, has been accidentally or intentionally damaged, has not been installed, maintained or operated in accordance with the furnished written instructions, or has been altered or modified in any way.

b) to any expenses, including labor or material, incurred during removal or reinstallation of the Product.

c) to any workmanship of the installer of the Product. This limited warranty is conditional upon:

(i) shipment, to the Manufacturer, of that part of the Product thought to be defective. Goods can only be returned with prior written approval from the Manufacturer. All returns must be freight prepaid.

(ii) determination, in the reasonable opinion of the Manufacturer that there exists a defect in material or workmanship.

Repair or replacement of any part under this Limited Warranty shall not extend the duration of the warranty with respect to such repaired or replaced part beyond the stated warranty period.

THIS LIMITED WARRANTY IS IN LIEU OF ALL OTHER WARRANTIES, EITHER EXPRESS OR IMPLIED, AND ALL SUCH OTHER WARRANTIES, INCLUDING WITHOUT LIMITATION IMPLIED WARRANTIES OF MERCHANTABILITY OR FITNESS FOR A PARTICULAR PURPOSE, ARE HEREBY DISCLAIMED AND EXCLUDED FROM THIS LIMITED WARRANTY. IN NO EVENT SHALL THE MANUFACTURER BE LIABLE IN ANY WAY FOR ANY CONSEQUENTIAL, SPECIAL, OR INCIDENTAL DAMAGES OF ANY NATURE WHATSOEVER, OR FOR ANY AMOUNTS IN EXCESS OF THE SELLING PRICE OF THE PRODUCT OR ANY PARTS THEREOF FOUND TO BE DEFECTIVE. THIS LIMITED WARRANTY GIVES THE ORIGINAL OWNER OF THE PRODUCT SPECIFIC LEGAL RIGHTS. YOU MAY ALSO HAVE OTHER RIGHTS WHICH MAY VARY BY EACH JURISDICTION.

USEFUL INFORMATION

MODEL: _____

SERIAL NUMBER: _____

DATE PURCHASED: _____

INSTALLED BY: _____

DATE INSTALLED: _____

For Technical Support, or to locate a distributor for service parts, contact Oceanaire at (847) 583-0311. Please indicate the Model Number and Serial Number of the unit to assure proper information and service parts.