

SHARP SERVICE MANUAL

S6009SE60APSR

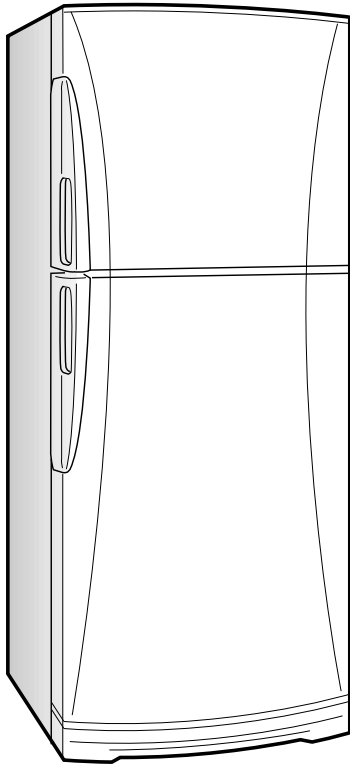

REFRIGERATOR-FREEZER

MODELS

SJ-58L-A2G/A2B/A2L/A2A

SJ-63L-A2G/A2B/A2L/A2A

SJ-68L-A2G/A2B/A2L/A2A

In the interests of user-safety (Required by safety regulations in some countries) the set should be restored to its original condition and only parts identical to those specified should be used.

DESTINATION R,Y

Refrigerant; HFC-134a

Refer to "HFC-134a COOLING UNIT" Service Manual for handling this refrigerant.

TABLE OF CONTENTS

	page
CAUTIONS AND INFORMATIONS	2
SPECIFICATIONS	3
DESIGNATION OF VARIOUS PARTS	4
LIST OF ELECTRICAL PARTS	5
WIRING DIAGRAM	6
FUNCTIONS	9
ASSEMBLING PROCEDURES OF MAIN PARTS AND CAUTIONS	12
MODIFICATION PROCEDURE OF THE DOOR OPEN SIDE	20
COOLING UNIT	23
REPLACEMENT PARTS LIST	25

CAUTIONS AND INFORMATIONS

In case of following troubles, the cause is not related with the failure of refrigerator.
Please mention the correct way to the customer for the use of refrigerator when the repairing.

1. Some foods freezed in the refrigerator compartment.

Do not place food directly in front of cold air outlet.
This may lead to the food freezing.

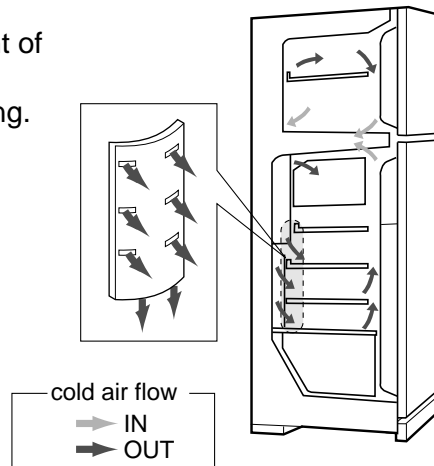

2. Some plastic parts were cracked or splitted.

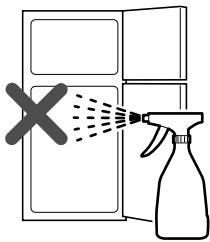

Some household cleaning chemicals may affect the internal food liner and plastic parts resulting in splitting or cracks occurring.

When cleaning all plastic parts inside this refrigerator, only use diluted dishwashing liquid(soapy water). Make sure that all plastic parts are thoroughly rinsed with water after cleaning.

3. IT IS NORMAL for the refrigerator to produce the following sounds.

Cracking or crunching sound;

Sound produced by expansion and contraction of inner walls and internal parts during cooling.

Squeaking sound;

Sound produced by expansion and contraction of internal parts.

Sound of flowing fluid (gurgling sound, fizzing sound);

Sound of refrigerant flowing in pipes (sound may become louder from time to time).

SPECIFICATIONS

Items		SJ-58L-A2	SJ-63L-A2	SJ-68L-A2
Type		2-Door	2-Door	2-Door
Outer dimensions (Including spacer)	Height	1620mm(63.8")	1720mm(67.7")	1820mm(71.7")
	Width	760mm(29.9")	760mm(29.9")	760mm(29.9")
	Depth	740mm(29.1")	740mm(29.1")	740mm(29.1")
Rated storage volume (Rated volume)		492 liter (17.4 cu.ft) F: 151 liter (5.3 cu.ft) R: 341 liter(12.1 cu.ft)	535 liter (18.9 cu.ft) F: 151 liter (5.3 cu.ft) R: 384 liter(13.6 cu.ft)	577 liter (20.4 cu.ft) F: 151 liter (5.3 cu.ft) R: 426 liter(15.1 cu.ft)
Defrosting	System	Heater system		
	Start	Automatic		
	Finish	Automatic		
Temperature control		Automatic (Adjustable)		
No-frost freezer		Yes		
Interior lamp		2		
Caster		4		
Evaporating pan		1		
Refrigerator Compartment	R glass shelf ass'y	2		3
	V glass shelf ass'y	1		
	Vegetable case	1		
	Fruit case	1		
	R door pocket	1		2
	Egg tray	2		
	Bottle pocket	2		
	Utility case pocket	1		
	Chilled case	1		
	Tube stand	2		
Freezer Compartment	Freezer shelf ass'y	1		
	Ice cube maker	Twin ice cube maker		
	Ice storage box	1		
	F door pocket	2		
Deodorizing system		Yes		

RATING

Items		SJ-58L-A2	SJ-63L-A2	SJ-68L-A2
Rated voltage	(V~)	220-240		
Rated frequency	(Hz)	50		
Climate class		T		
Rated input	(W)	170-190		
Rated input of heating elements	(W)	138-164		
Refrigerant (Charging quantity)		HFC-134a(120g)	HFC-134a(125g)	HFC-134a(130g)
Net Weight	(kg)	81	83	88

PLUG TYPE

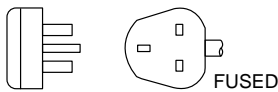
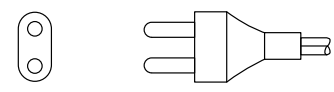
Plug cord	3 pin	2 pin
Plug type	BF with PUB label 	C-2 
Destination mark	R	Y

COLOR

Items	-A2G	-A2B	-A2L	-A2A
Outside color	Gray	Blue	Green	Beige
Inside color	White			

OPTIONAL ITEM

SJ-L838LD (REFRIGERATOR HINGE KITS). For changing the door to left side opening.

DESIGNATION OF VARIOUS PARTS

The names are the denominations used in the REPLACEMENT PARTS LIST.

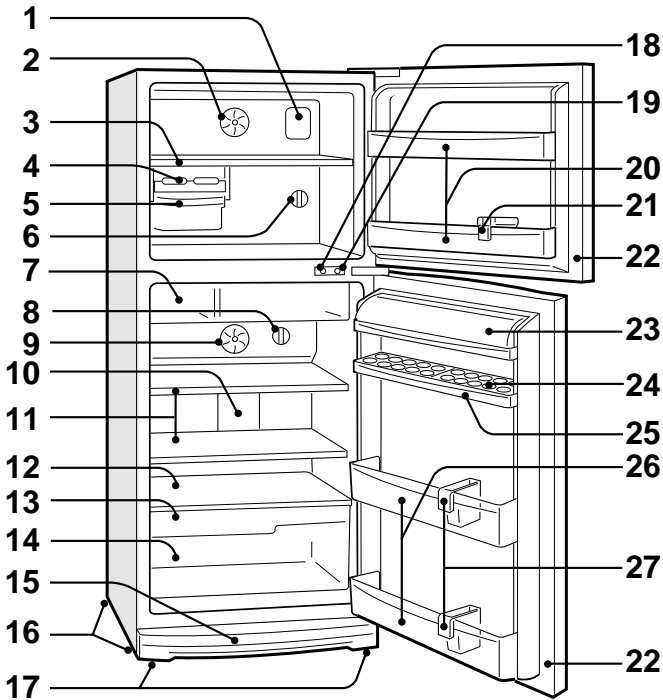
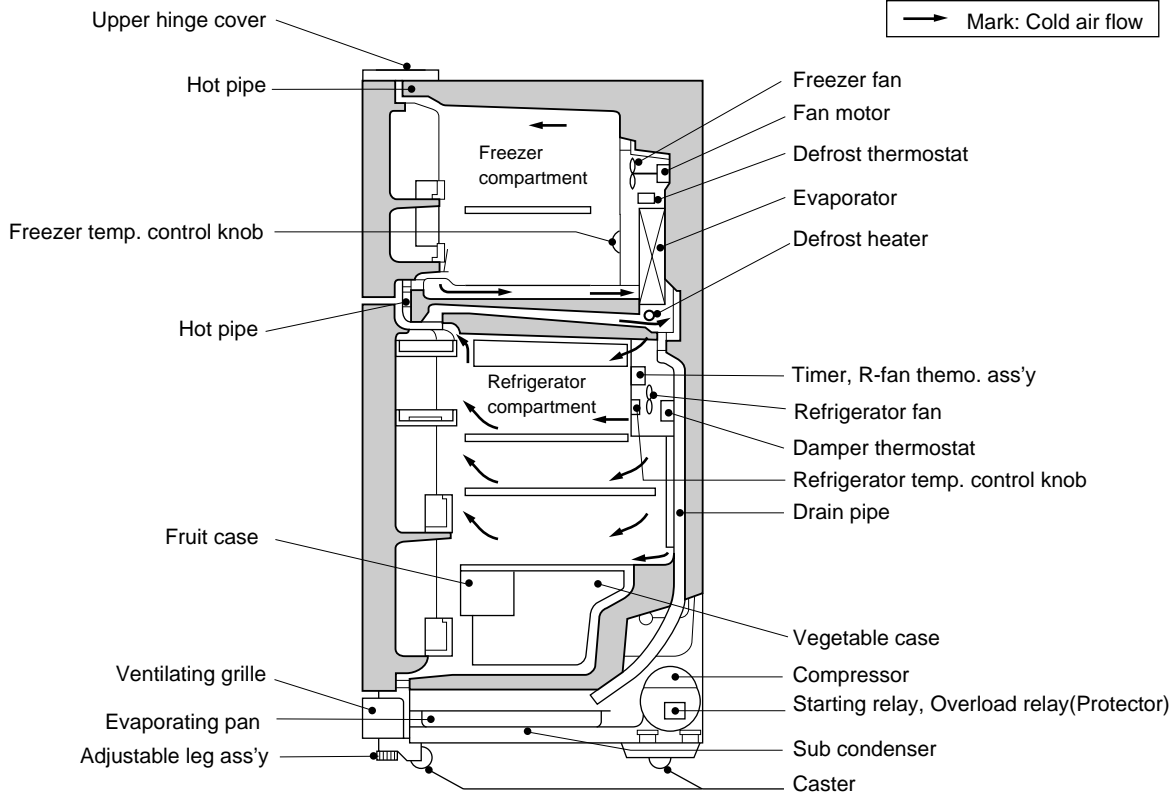

Figure D-1. External Description

1. Freezer light(Lamp)
2. Freezer fan
3. Freezer shelf(F shelf ass'y)
4. Ice cube maker
5. Ice cube box(Ice storage box)
6. Freezer temp. control knob
7. Chilled case
8. Refrigerator temp. control knob
9. Refrigerator fan
10. Refrigerator light(Lamp)
11. Refrigerator shelf(R glass shelf ass'y)
(SJ-58L/63L; 2 shelves, SJ-68L; 3 shelves)
12. Shelf(V glass shelf ass'y)
13. Fruit case
14. Vegetable crisper(Vegetable case)
15. Evaporating pan & cover
16. Caster
17. Adjustable feet(Adjustable leg ass'y)
18. Fan & light switch(for freezer)
19. Fan & light switch(for refrigerator)
20. Freezer pocket(F door pocket)
21. Water cup
22. Magnetic door seal(Door packing)
23. Utility pocket(Utility case pocket)
24. Egg holder(Egg tray)
25. Free pocket(R door pocket)
(SJ-58L/63L; 1 pocket, SJ-68L; 2 pockets)
26. Bottle pocket
27. Bottle guard(Tube stand)



※ This figure shows SJ-63L .

Figure D-2. Constructions

LIST OF ELECTRICAL PARTS

ITEMS	TYPE NAME	RATING	SPECIFICATIONS	
Thermostat	MM1-8123	125V 6A 250V 3A	(At normal notch) ON/OFF : -19/-24°C	
Defrost thermostat	S101	250V 8A	Open/Close : 10/1°C	
Thermo. fuse	SF70E	250V 10A	Working temp. : 70°C	
F-fan motor	3R00044B	220-240V 50/60Hz	Working with ø100 fan	
R-fan motor	3R00122A	220-240V 50/60Hz	Working with ø80 fan	
(R-fan fuse)	123	250V 2A	Cut OFF 130°C	
Defrost heater	MM6-4198	220-240V 353Ω	150W at 230V	
Door switch	DSD-5	250V 0.25A	4 terminals push-button type	
Damper thermostat	MM1-6170	—	Open/Close : 3/-2°C	
Defrost timer	TMDF904FD2	220-240V 50/60Hz	Integration type Cycle time : 10.8/9.0 hours(50/60Hz) Delay time : 4.3/3.6 min.(50/60Hz)	
Lamp socket (F/R)	—	250V 1A	E-12(Hard plastic body type)	
F-lamp	—	240V 10W	E-12	
R-lamp	—	240V 15W	E-12	
R-fan thermo. ass'y	R-fan thermo. R-fan thermo.heater	S101 RSS2	250V 8A 350V, 2W, 10kΩ	Open/ Close : 7/15°C 1.1W at 230V

SJ-58L,63L

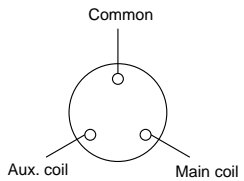
Compressor	GLY80AA	220-240V/50Hz	Cooling capacity : 197kcal/h(50Hz) Main coil : 10.3Ω Aux. coil : 14.2Ω (at 25°C)
			
Starting relay	UH3003-7	—	14.0 Ω
Overload relay(Protector)	4TM308NFBYY	—	Open/ Close : 120/61°C

SJ-68L

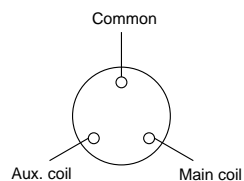
Compressor	GLY90AA	220-240V/50Hz	Cooling capacity : 220kcal/h(50Hz) Main coil : 8.8Ω Aux. coil : 14.2Ω (at 25°C)
			
Starting relay	UH3003-7	—	14.0 Ω
Overload relay(Protector)	4TM757NFBYY	—	Open/ Close : 120/61°C

WIRING DIAGRAM

Be sure to replace the electrical parts with specified ones for maintaining the safety and performance of the set.

- G : GRAY
- Br : BROWN
- O : ORANGE
- Y : YELLOW
- R : RED
- P : PINK
- B : BLUE
- Bk : BLACK
- S-B : SKY-BLUE
- G-Y : GREEN-YELLOW
- W : WHITE

● CONNECTED IN TERMINAL BOX

□ CONNECTOR

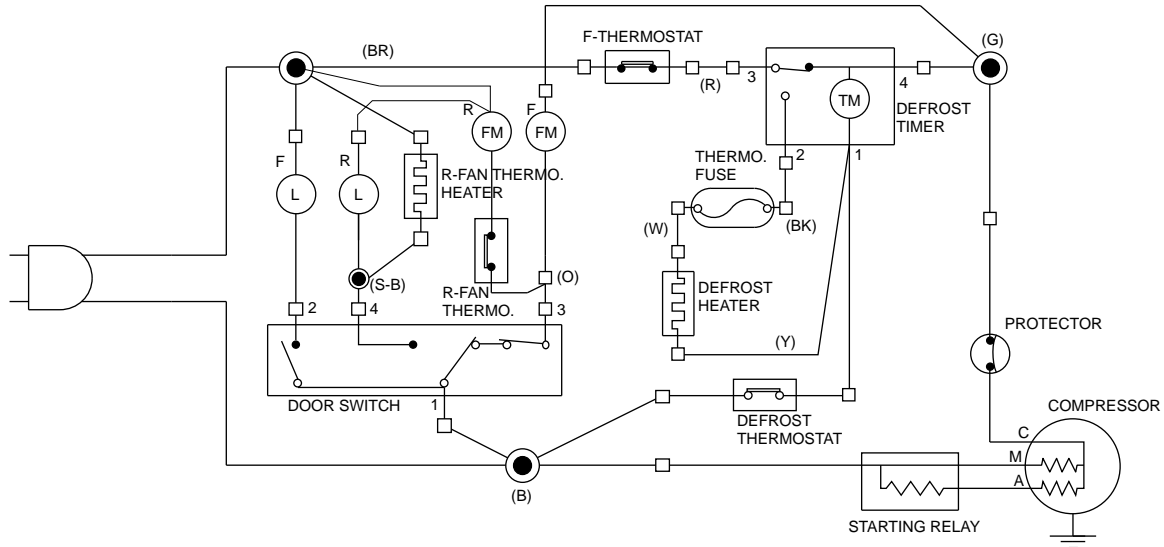

Figure W-1. Wiring Diagram (2 pin plug region)

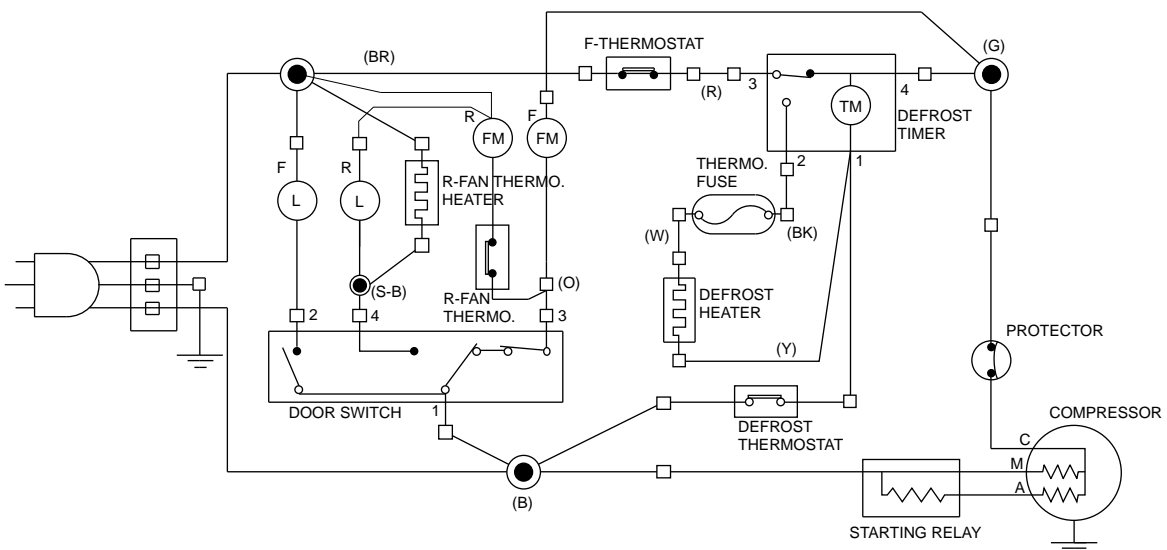

Figure W-2. Wiring Diagram (3 pin plug region)

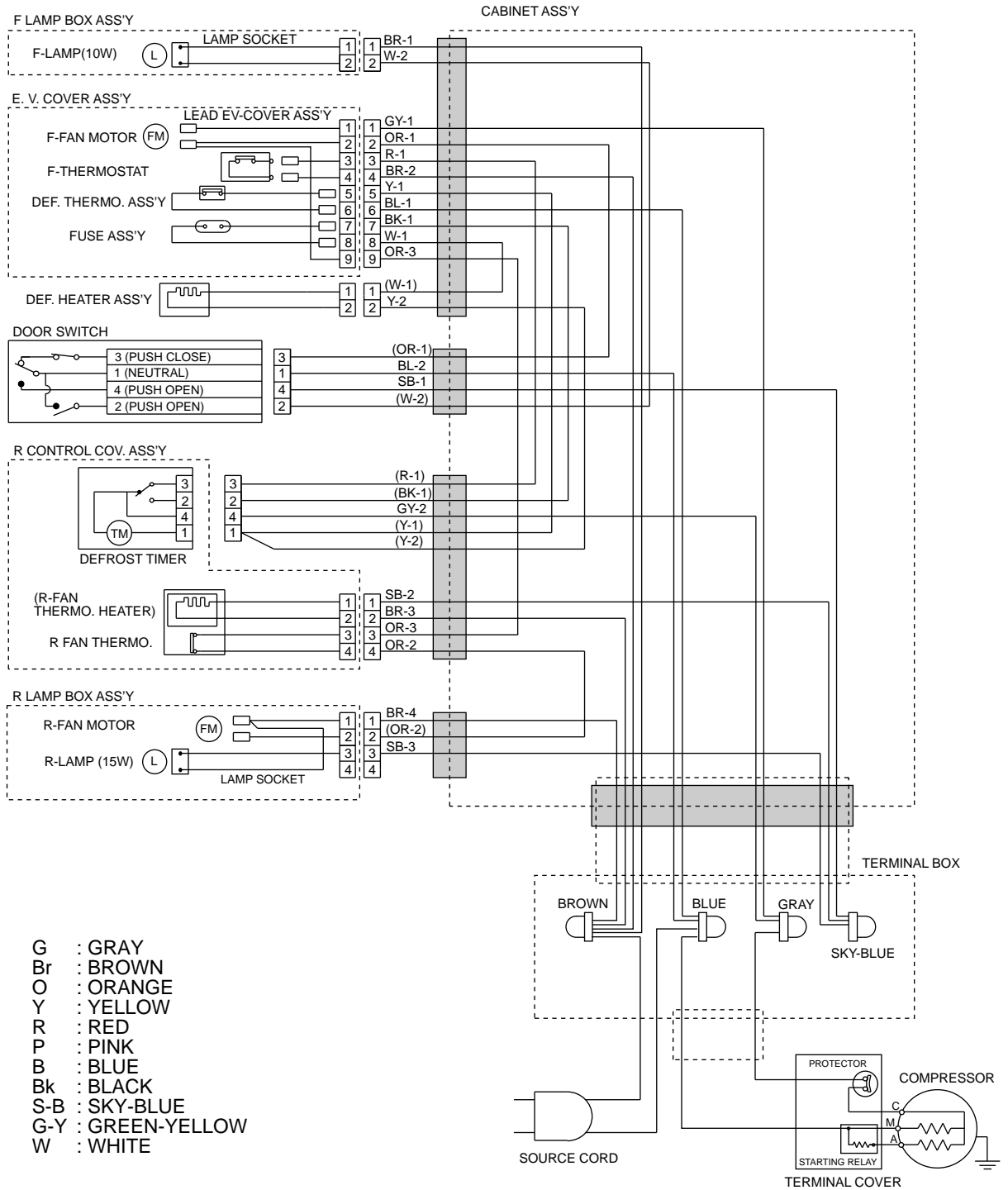

Figure W-3. Electric Accessories Layout (2 pin plug region)

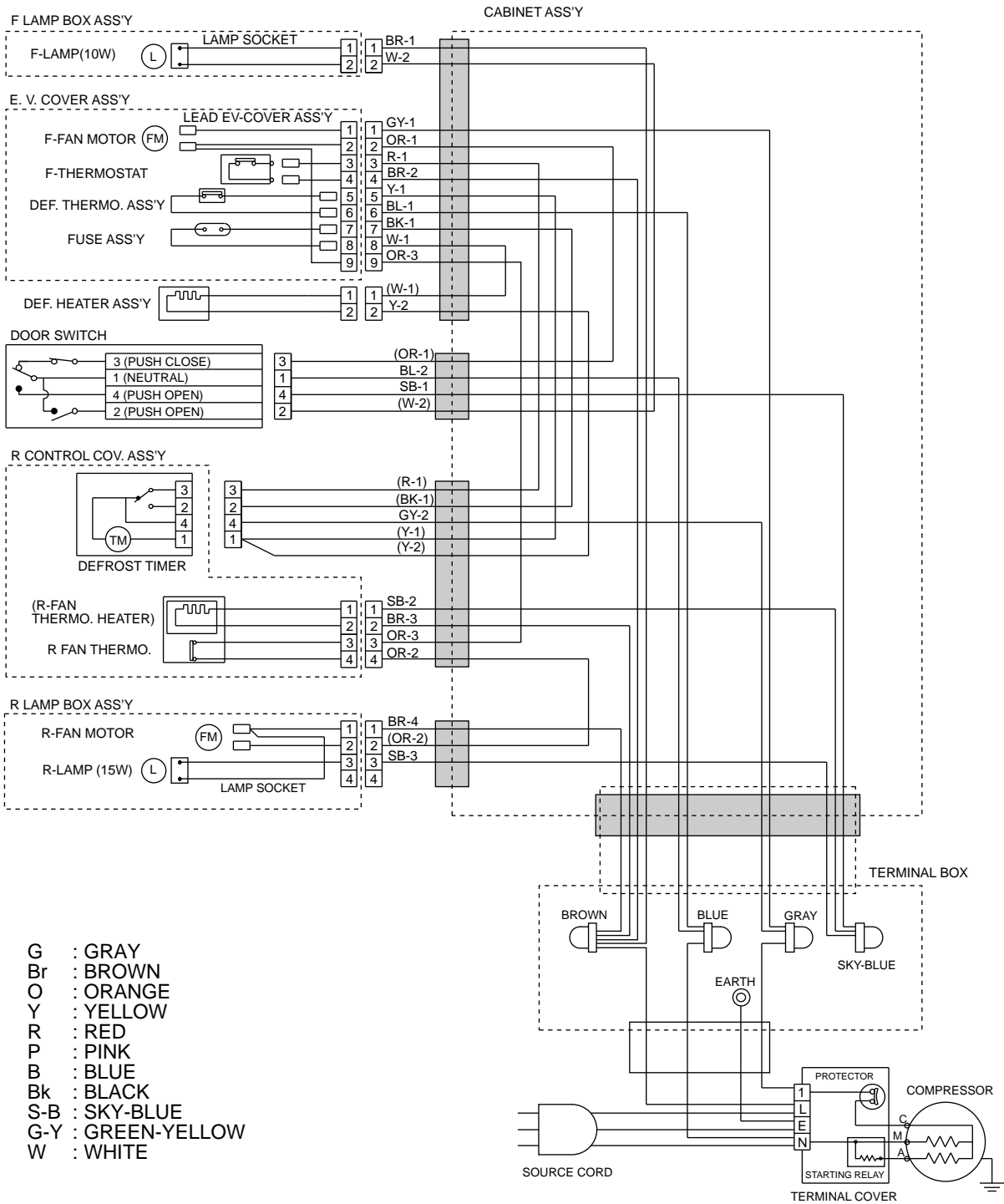

Figure W-4. Electric Accessories Layout (3 pin plug region)

FUNCTIONS

1. ADJUSTABLE TEMPERATURE CONTROL

(1) Temperature control of freezer

- Thermostat (senses freezer temperature) operates on ON/OFF switchover to control the compressor and cool air circulating fan (F-fan motor), and allows the freezer temperature to keep at a suitable temperature.
- However adjust the freezer temp. control knob as follows depending upon the storing condition of foods.

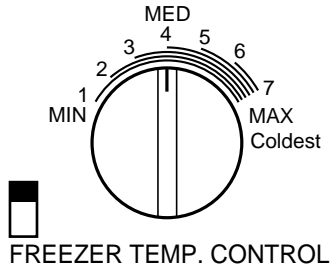

FREEZER TEMP. CONTROL

Figure F-1.

KNOB SETTING	PURPOSE
MAX(Coldest)	● For making ice rapidly or fast freezing.
▲	● When restocking with fresh food.
MED	● For normal freezing.
▼	● For storing frozen food for a short period (up to one month).
MIN	● When frozen food or ice cream is not stored.

(2) Temperature control of refrigerator

- Damper-thermostat senses temperature of the refrigerator and changes the opening angle of the damper automatically. However, as the Damper-thermostat has no function to switch on or off the compressor and F-fan motor, the freezer temperature control causes temperature in the refrigerator to vary to some extent.
- However, adjust the refrigerator temp. control knob as follows depending upon the cooling condition.

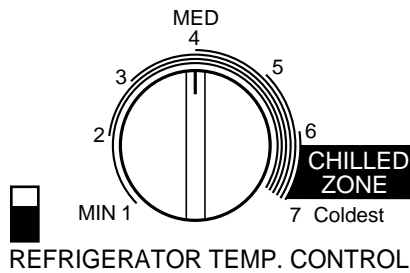

REFRIGERATOR TEMP. CONTROL

Figure F-2.

KNOB SETTING	PURPOSE
CHILLED ZONE (Coldest)	● For keeping freshness of food longer.
▲	● When the refrigerator does not provide sufficient cooling.
MED	● For normal operation.
▼	● When the refrigerator provides excessive cooling.
MIN	

- When the temperature of the refrigerator is higher, R-fan thermo. senses the temperature and the refrigerator is cooled efficiently by running of R-fan motor. R-fan thermo. heater energizes when the door is opened intend to promote to running of R-fan motor.

- NOTE:
- The refrigerator temperature is affected also by the freezer temperature. If the freezer temp. control knob is set at the position "MAX", the temperature tends to be lower than the following values, and if set at near the position "MIN", temperature tends to be higher.
 - If the refrigerator is operated for a long time with the freezer temperature control sets the "MAX" position, foods stored in the refrigerator compartment may also freeze.
 - When refrigerator temperature control sets to the "CHILLED ZONE", some foods stored may freeze. In this case adjust control set back to the "MED" position.
 - When refrigerator temperature control sets to the "CHILLED ZONE", some foods stored in chilled case may also become frozen.

(3) Reference value of temperature

SETTING OF FREEZER TEMP. CONTROL KNOB	MAX (Coldest)	MED	MIN
Freezer temperature	Approx. -21°C	Approx. -18°C	Approx. -15°C

SETTING OF REFRIGERATOR TEMP. CONTROL KNOB	CHILLED ZONE (Coldest)	MED	MIN
Refrigerator temperature	Approx. 0°C	Approx. 3°C	Approx. 6°C
Chilled room temperature	Approx. -3°C	Approx. 1°C	Approx. 4°C

The values shown above refer to the case where the freezer temp. control knob is set at "MED".

The values shown above refer to the measurement carried out center area and 1/3 of overall height from the bottom at each of the refrigerator and the freezer after machine has been operated at an ambient temperature of 30°C with no food stored and the door closed until the temperature is stabilized.

The values vary depending upon frequency of opening and closing the door, ambient temperature, amount of stored foods and manner of storing foods.

2. DEFROSTING

(1) No defrosting operation is necessary

No defrosting operation is necessary. As this machine is so designed that a built-in evaporator cools air and a fan circulates cooled air, neither the freezer nor the refrigerator is frosted, though the evaporator is frosted. The frosted evaporator is defrosted automatically due to the function of defrosting timer and heater, requiring no defrosting operation.

(2) Where is melted frost brought

1. Melted frost is brought into the evaporating pan at the bottom of the set and is evaporated here by the heat of sub condenser.
2. Be sure that the evaporating pan is inserted correctly and is level.

(3) The following circuit diagrams in the table show automatic defrosting function of the refrigerator with timer and defrost thermostat.

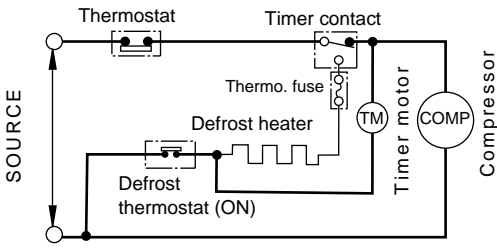
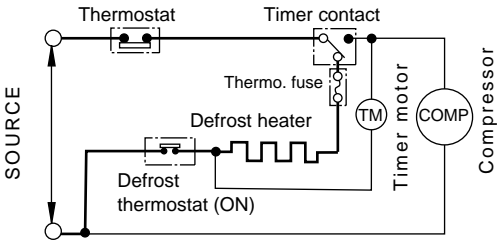
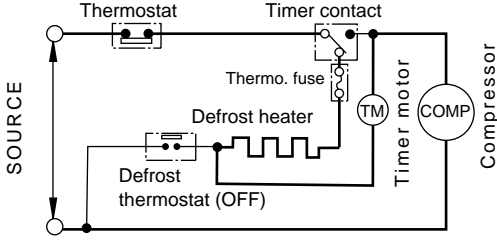
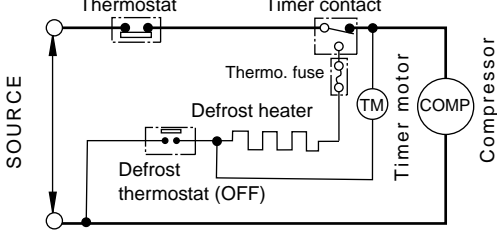
Operation	Electric diagram	Description
<p>1. Cooling (Normal)</p>	<ul style="list-style-type: none"> ● Defrost thermostat ON ● Compressor running ● Timer motor running  <p style="text-align: center;">Figure F-3.</p>	<p>The integration timer integrates running time of the compressor. When it reaches cycle time of defrost timer, the timer contact is changed to start defrosting.</p>
<p>2. Defrosting (Time 20 to 30 min.)</p>	<ul style="list-style-type: none"> ● Defrost thermostat ON ● Compressor stops ● Timer motor stops  <p style="text-align: center;">Figure F-4 .</p>	<ul style="list-style-type: none"> ● The timer contact is changed to start defrosting, the timer motor stops, and power is supplied to the defrost heater. ● It takes about 20 to 30 min. to defrost. When little frosted, the defrosting takes little time. When much frosted, the defrosting takes much time.
<p>3. Drain (Time approx. 5 min.)</p>	<ul style="list-style-type: none"> ● Defrost thermostat OFF ● Compressor stops ● Timer motor running  <p style="text-align: center;">Figure F-5.</p>	<p>When the defrost thermostat becomes OFF, the timer motor starts running. During the operation time (delay time of defrost time) defrosted water is drained outside the refrigerator.</p>
<p>4. Restart (Time approx. 5 min.)</p>	<ul style="list-style-type: none"> ● Defrost thermostat OFF ● Compressor running ● Timer motor stops  <p style="text-align: center;">Figure F-6.</p>	<ul style="list-style-type: none"> ● Timer contact is changed to cooling operation and the compressor starts running and the timer motor stops. ● Defrost thermostat contact becomes ON when it's cooled. And the timer motor starts running. (Figure F-3.)

(4) As a reference to determine the causes of trouble, malfunction and phenomena are described below. Refer to the following when repairing.

1. Disconnection of defrost heater

As off-cycle defrosting is performed, the defrosting time is extremely prolonged. Each time defrosting is started, the freezer temperature rises and a portion of ice and stored foods are melted.

2. Melted thermo. fuse or opened-circuit due to the defect of defrost thermostat.

When the above mentioned trouble occurs in cooling operation, the timer motor does not run, defrosting will not take place, and consequently freezing is caused. In the above mentioned condition, when the timer shaft is turned by hand to defrost, the timer motor runs during the operation time. However, the motor stops from the time when the contact is changed, and freezing causes.

NOTE:

- As the thermo. fuse assembly is intended to prevent dangers, do not use it under shorted condition even for a short period.

3. DEW PREVENTION

The hot pipe, namely D.P.-condenser, is arranged around the flange part of cabinet and the C-partition plate, preventing dew from being generated on the cabinet.

NOTE:

- D.P.-condenser pipe may be felt hot if touched by hand while the compressor is in operation.
- If you are asked about this, please explain that the hot pipe serve to prevent the dew generation.

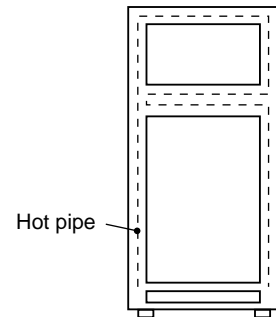

Figure F-7

4. INSPECTION OF INITIAL STARTING

(1) Inspection of cooling unit

1. Set the temperature control knob to "MAX" and check that the compressor starts to operate.
2. Depress the door switch to run the fan and check that cool air is blown out of the cold air outlet of the freezer and the refrigerator.
3. When the compressor does not work, check that the timer is not set to "defrost" position.
4. It takes about an hour and a half or two hours to put food in the refrigerator after starting operation.

NOTE:

- After return the temperature control knob to "MED" position.
- When the refrigerator is operated initially after installed, the compressor may vibrate excessively for 1 to 2 min. However, vibration becomes normal if it is continuously operated.

(2) Inspection of defrost device

Operate the refrigerator for 20 to 30 min. and then check the defrost device in the following procedures : Allow 5 min. to restart the compressor since immediate starting after stopping will cause unsmooth operation.

1. Turn the timer shaft clockwise with a screw driver.
 At this time, make certain the timer clinks and the compressor stops.
2. After more than 5 min., turn the shaft further to operate.
 Make certain cooling operation is started again.

ASSEMBLING PROCEDURES OF MAIN PARTS AND CAUTIONS

CAUTION: DISCONNECT THE UNIT FROM THE POWER SUPPLY BEFORE ANY REPAIRING.

1. R-CONTROL COV. ASSEMBLY

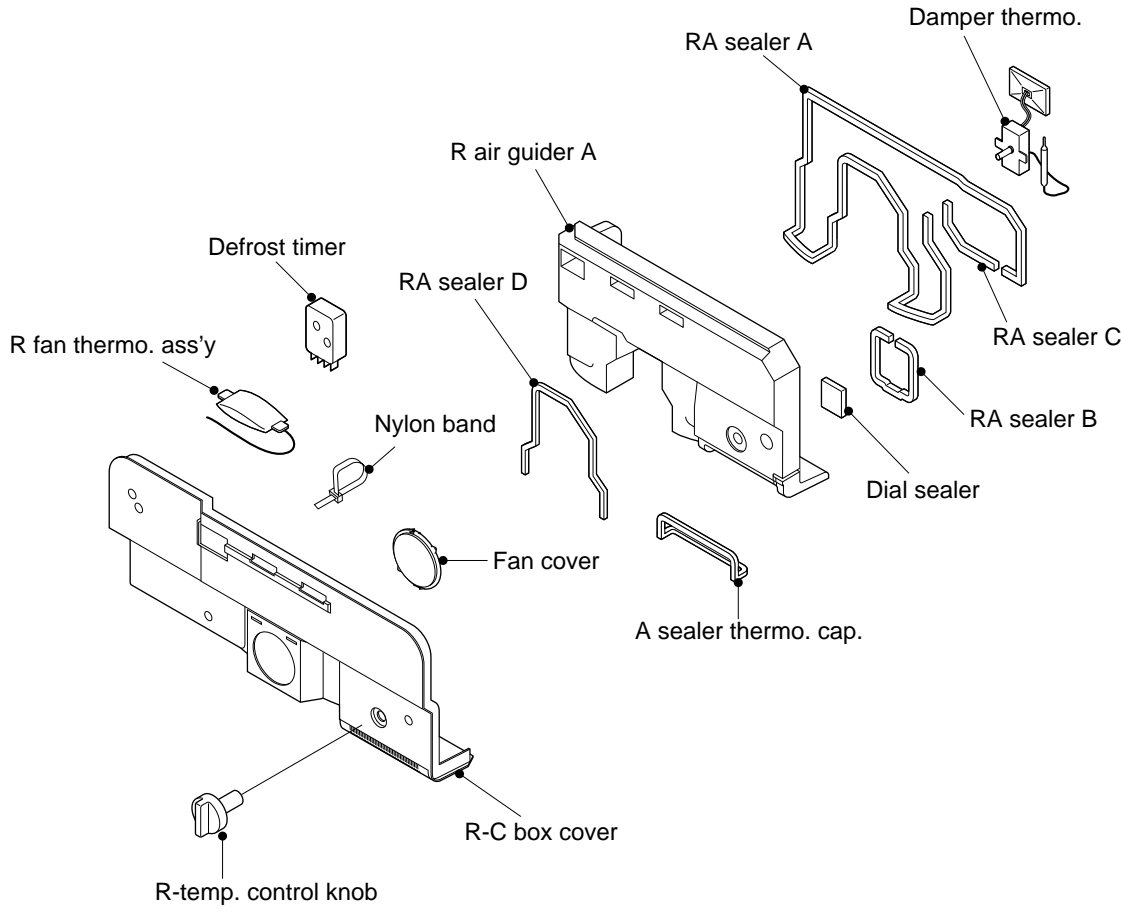

Figure A-1

(1) Forming sensor of Damper thermo.

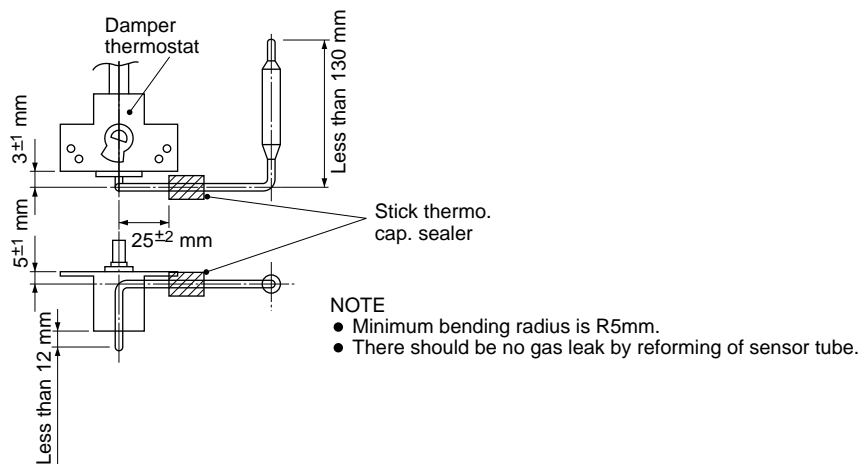

Figure A-2

After forming, fix it to the refrigerator.

(2) Sticking of sealers to R air guider A.

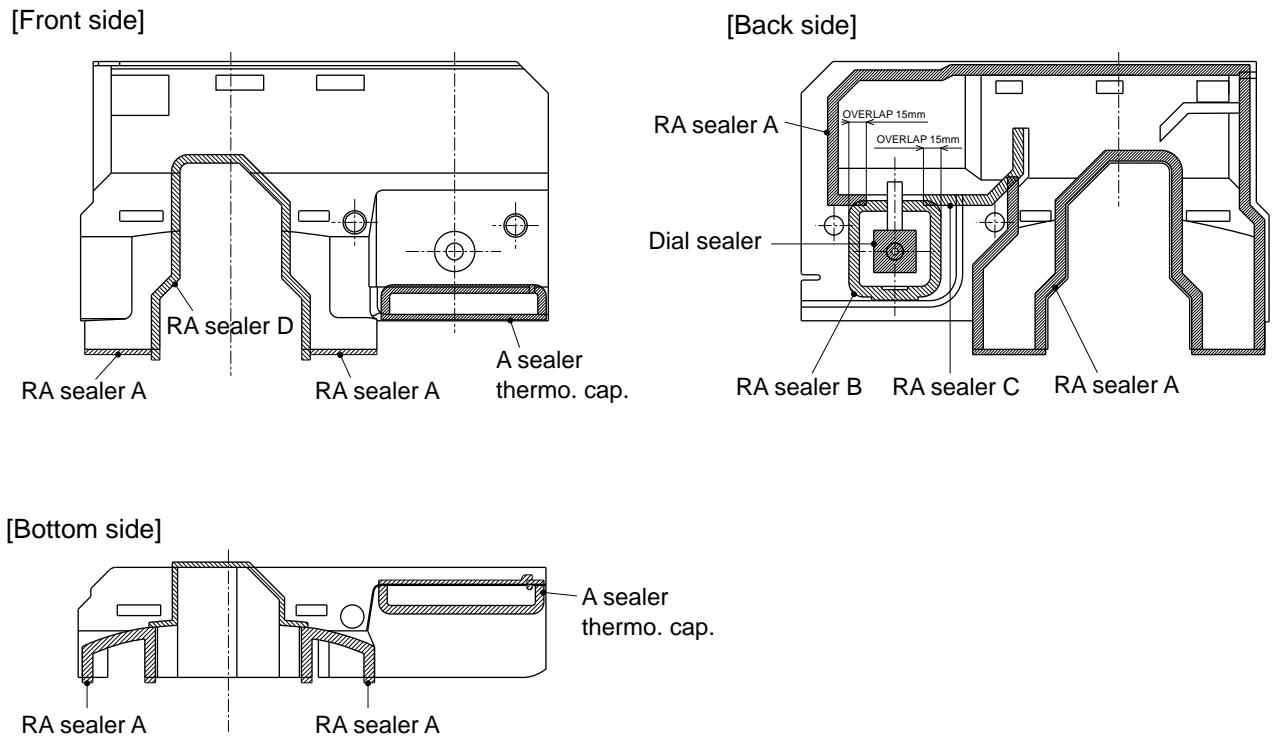

Figure A-3

(3) Fixing of Defrost timer, R fan thermo. ass'y cover to R-C box cover.

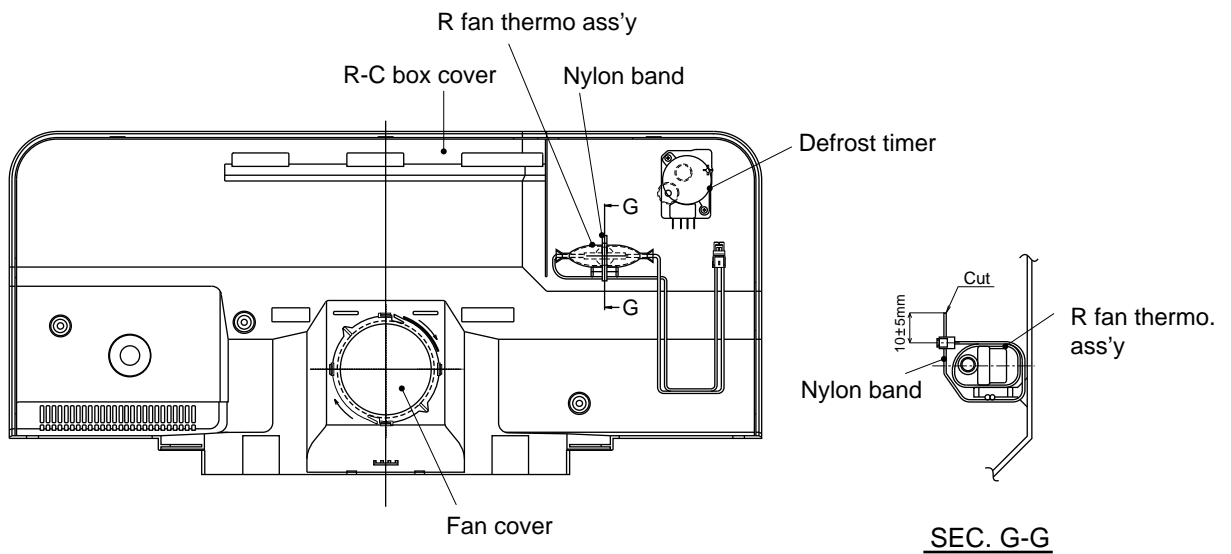

Figure A-4

2. R LAMP BOX ASSEMBLY

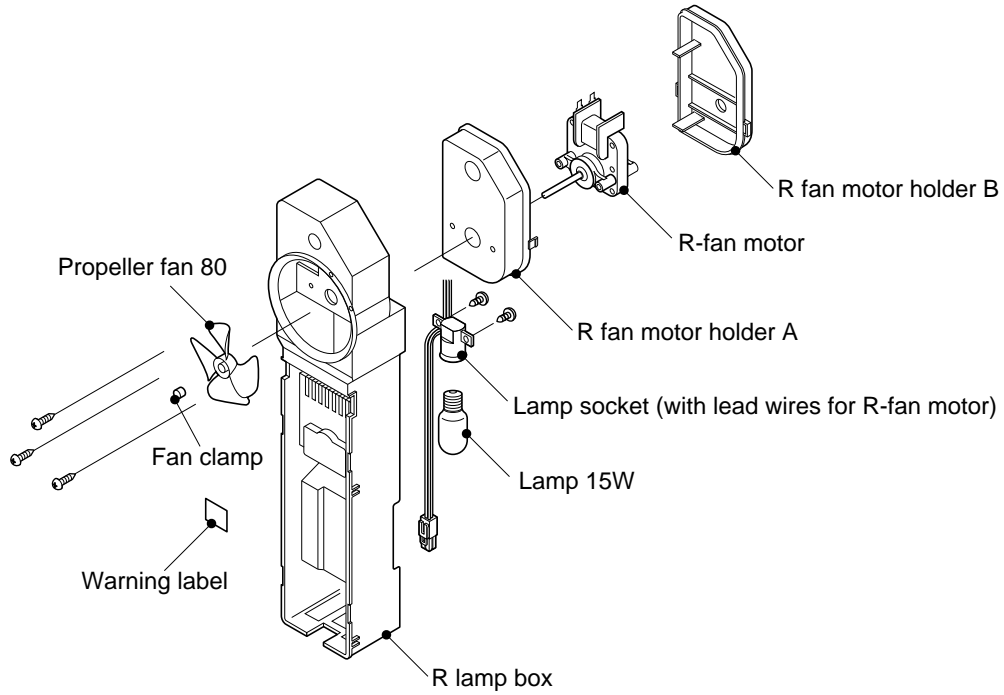

Figure A-5

(1) Fixing of Lamp and Lamp socket.

- (1)-1 Screw Lamp 15W into Lamp socket.
- (1)-2 Fix Lamp socket on R lamp box by tapping screws.

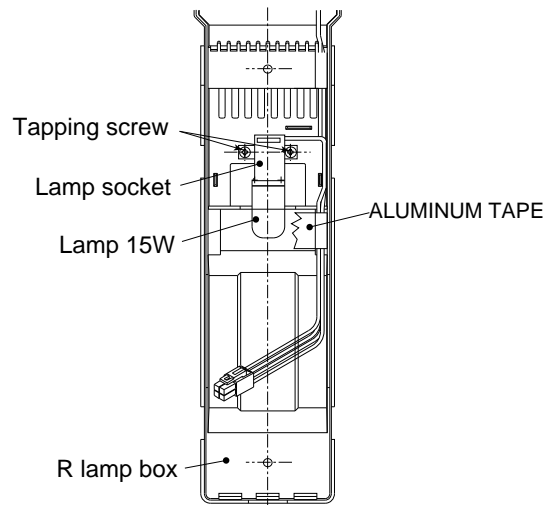

Figure A-6

(1)-3 Insert the terminal of Lamp socket to R-fan motor.

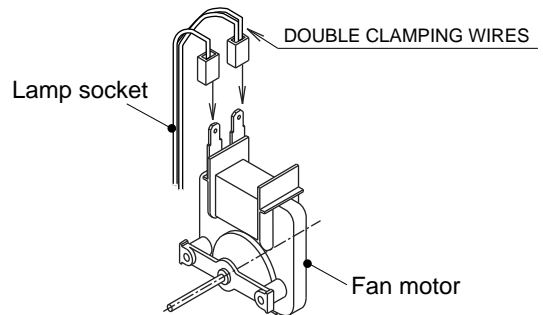

Figure A-7

(2) Fixing of R-fan motor and Fan

- (2)-1 Set R-fan motor holder A to R lamp box by tapping screw.
- (2)-2 Set R-fan motor to R fan motor holder A by machine screw.
- (2)-3 Set R fan motor holder B to A.

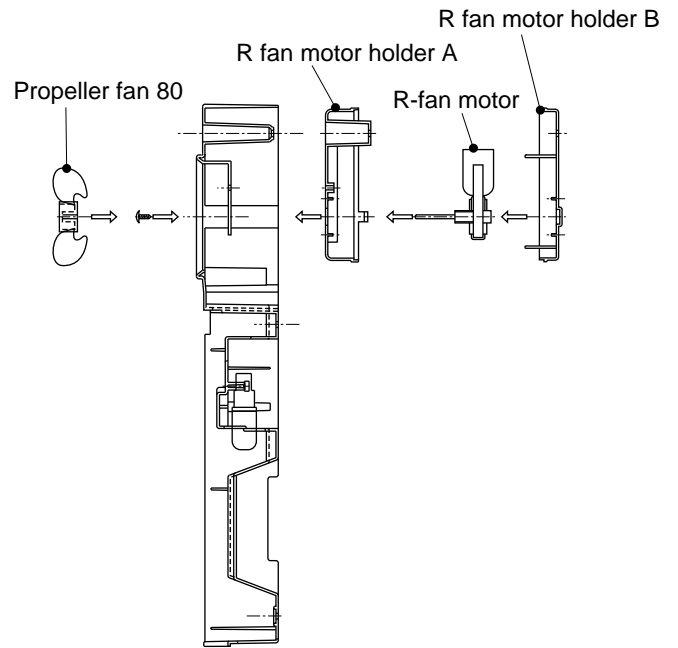

Figure A-8

- (2)-4 Set Fan clamp to Propeller fan 80 and insert it to the shaft of R-fan motor.

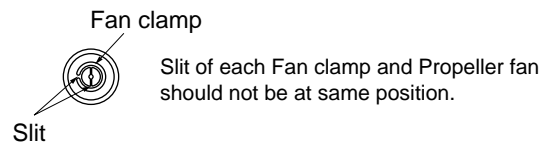
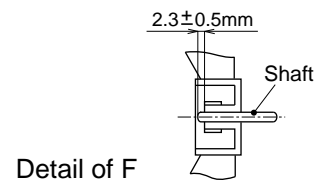
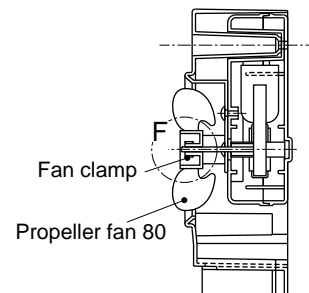

Figure A-9

(3) Sticking Warning label.

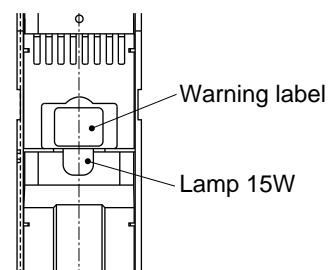

Figure A-10

3. E.V COVER ASSEMBLY

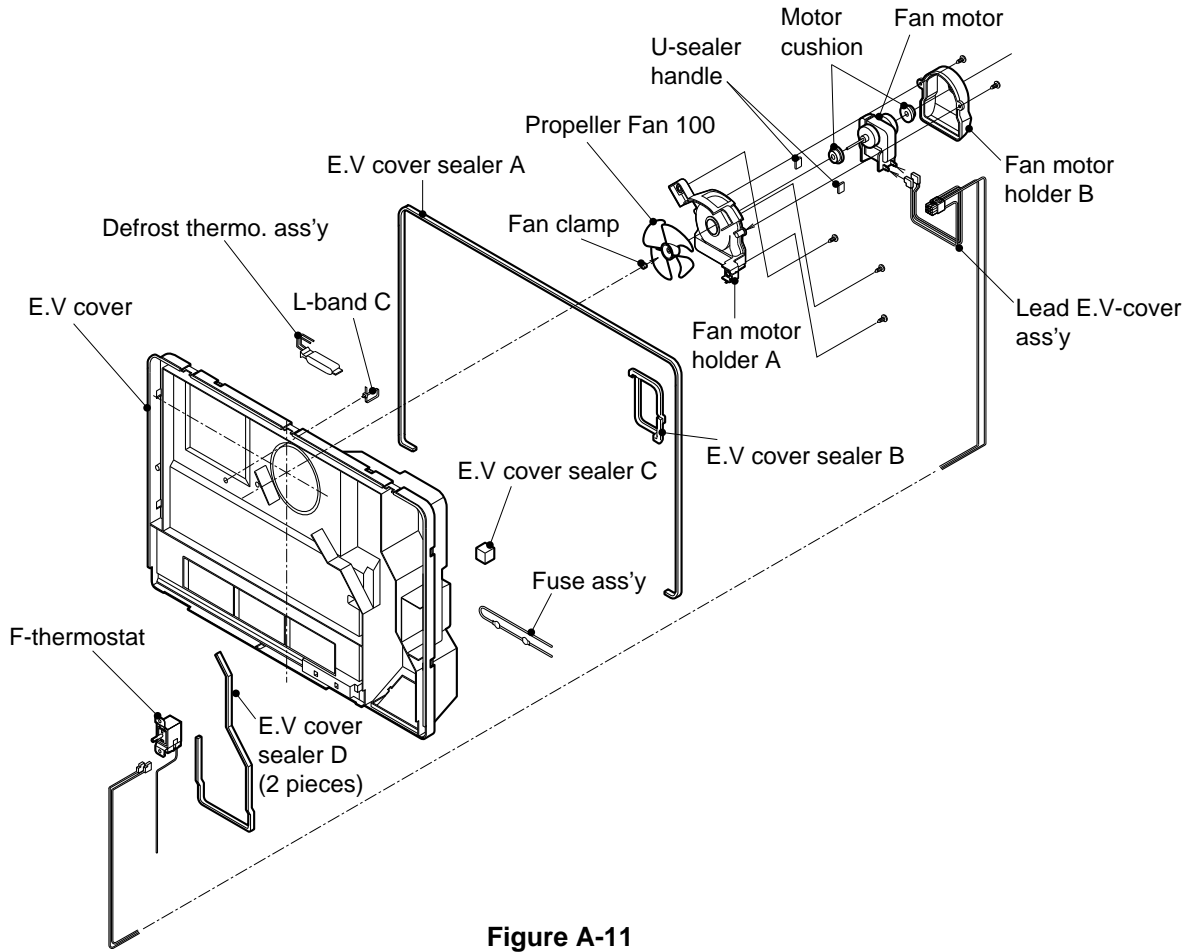

Figure A-11

(1) Sticking of Sealers to E.V cover

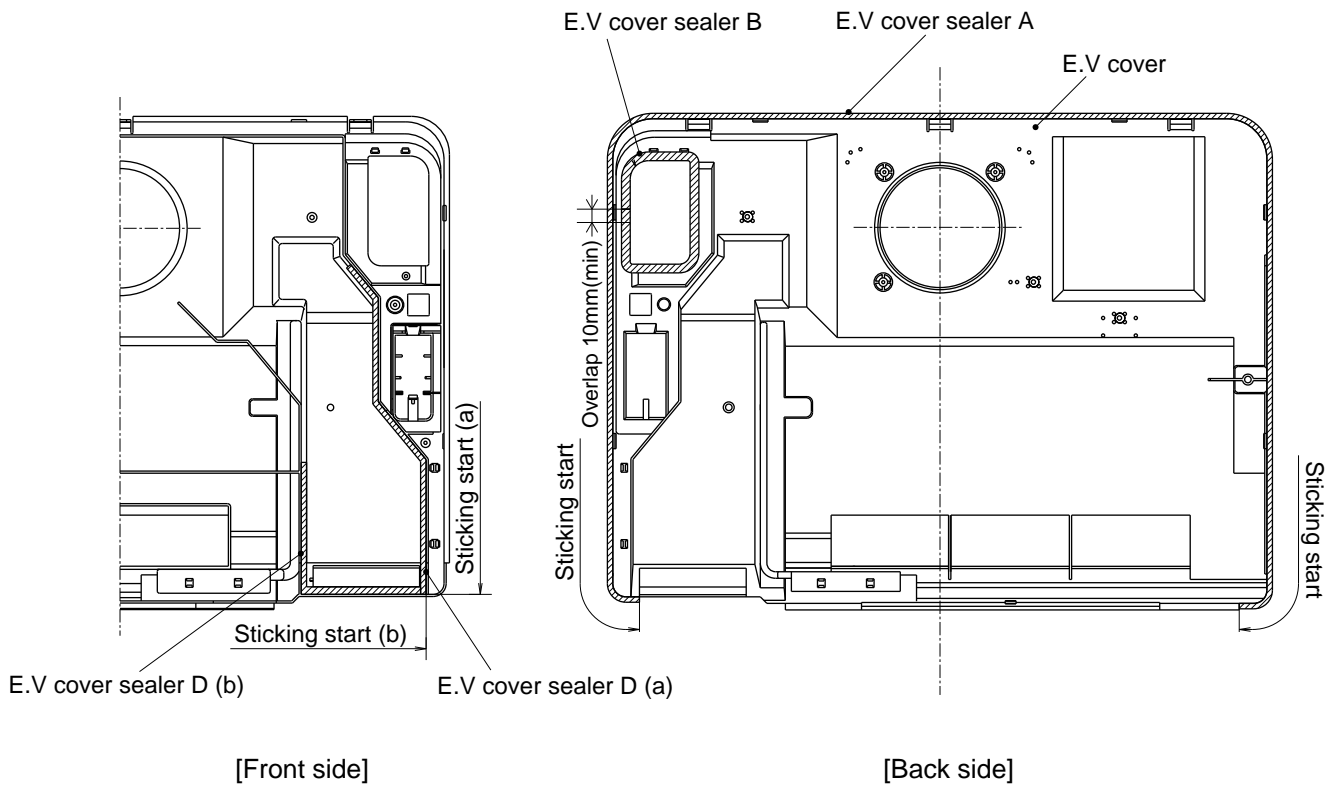

Figure A-12

(2) Fixing of Fan motor and Fan

(2)-1 Stick U-sealer handle to Fan motor holder A.

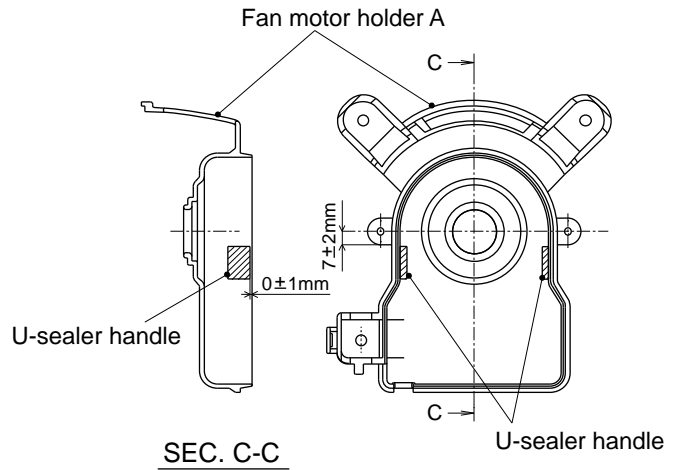

Figure A-13

(2)-2 Insert the terminals of Lead EV-cover ass'y to R-fan motor.

(2)-3 Fix two Motor cushions to R-fan motor, and set it at Fan motor holder A and B. Then fix with Tapping screw.

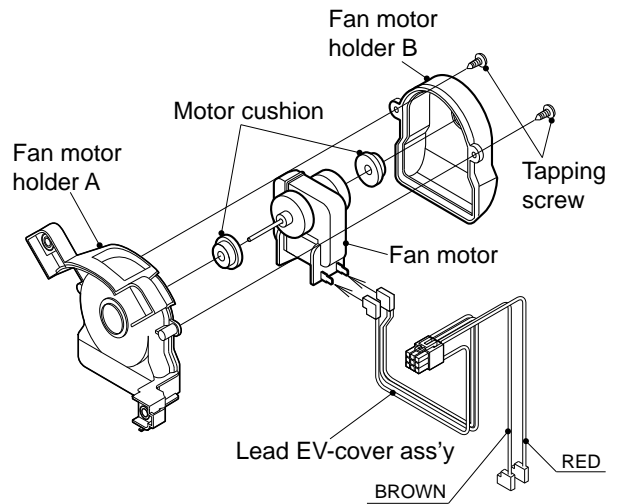

Figure A-14

(2)-4 Set Fan clamp to Propeller fan 100 and insert it to the shaft of Fan motor.

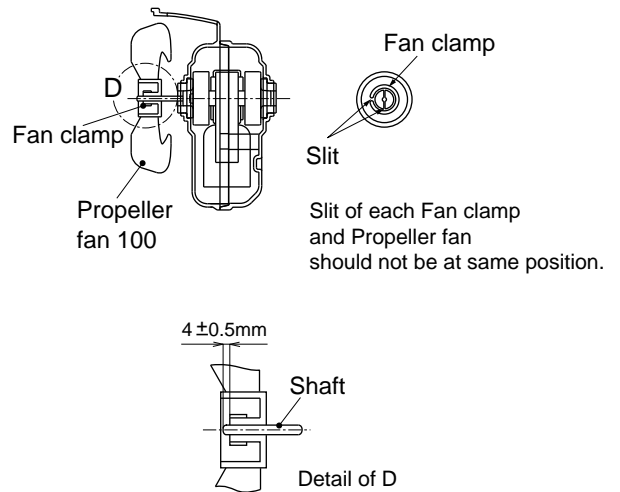

Figure A-15

(3) Setting of Fan motor ass'y , Defrost thermo. ass'y and Fuse ass'y

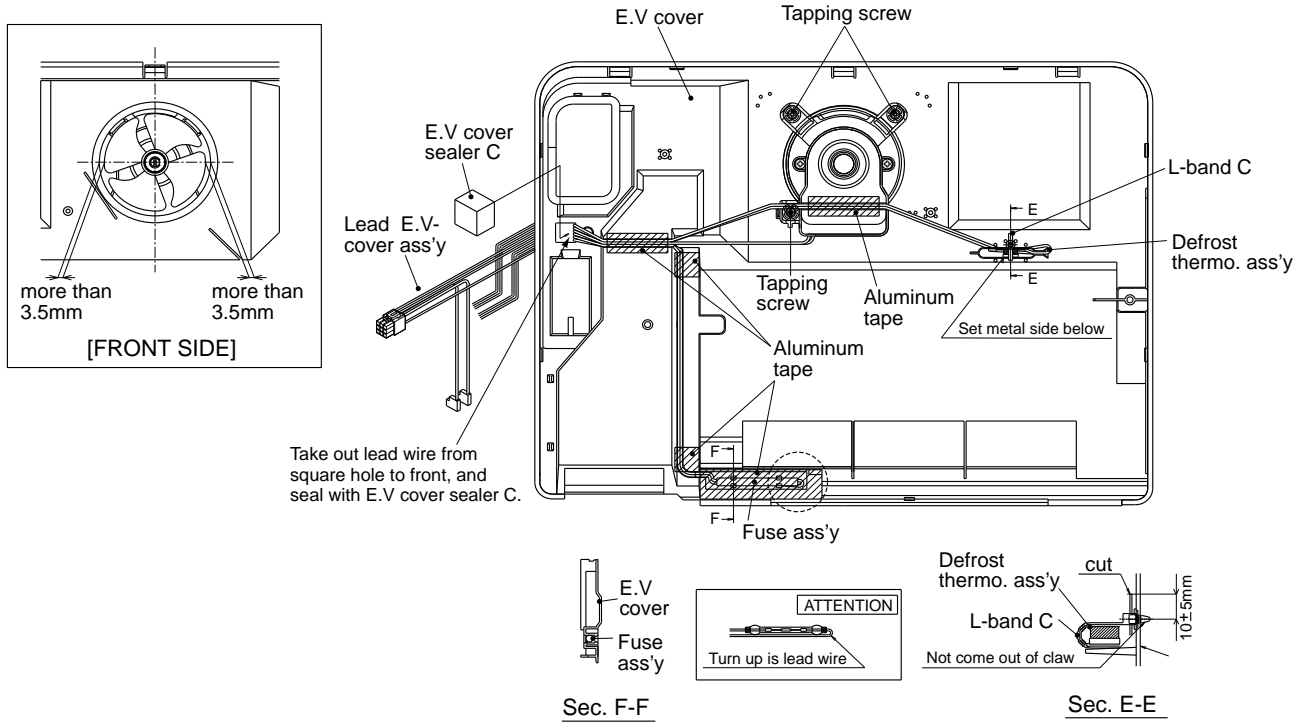
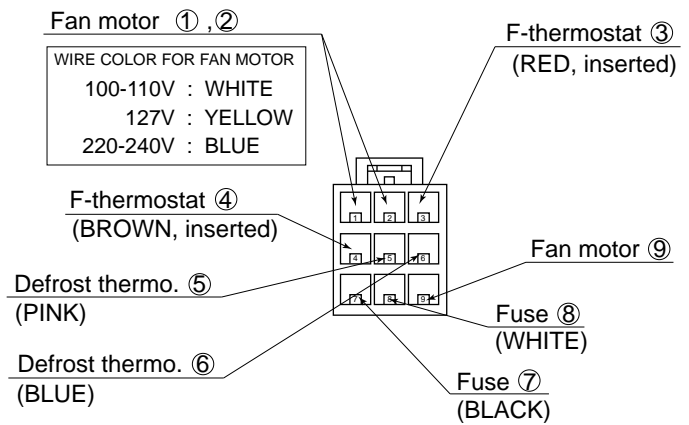

Figure A-16

(4) Inserting of pins



Note • Pins should be inserted surely, and check by pulling it.

Figure A-17

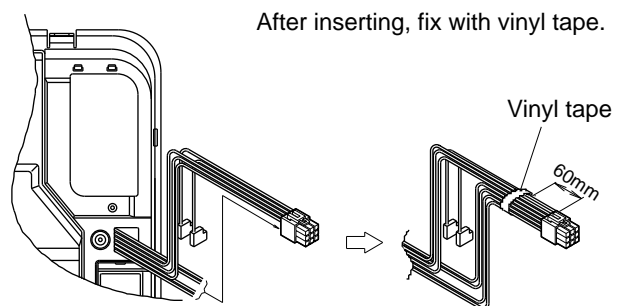
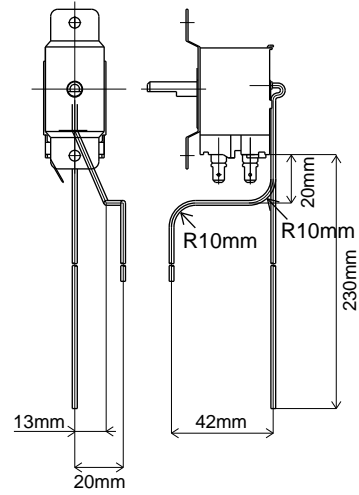

Figure A-18

(5) Setting of F-thermostat

(5)-1 Form capillary tube of F-thermostat.



Note
• Bending radius of capillary tube should be from R5mm to R10mm.

Figure A-19

(5)-2 Insert terminal of Lead EV-cover ass'y.

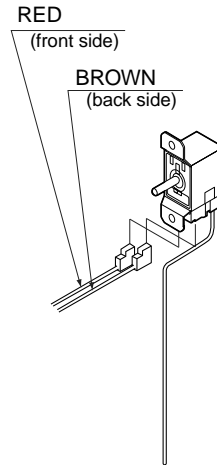

Figure A-20

(5)-3 Set to E.V cover.

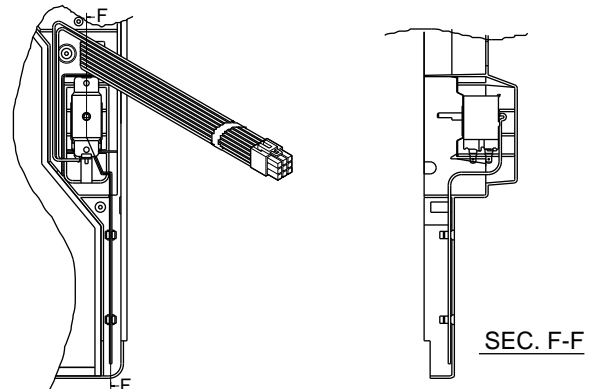

Figure A-21

MODIFICATION PROCEDURE OF THE DOOR OPEN SIDE

It is possible to change the door to left side opening.



To modify the door to left side opening, REFRIGERATOR HINGE KITS (for left side opening) SJ-L838LD (optional item) is necessary.

These kits are used to change the refrigerator doors from right to left opening. if you wish to change the door to left opening for some reason, such as restricted installation space, **ask your authorized service agent for this modification.**

by SJ-L838LD OPERATION MANUAL

Parts list

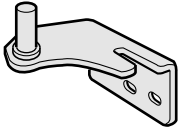
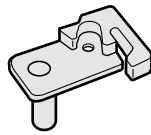
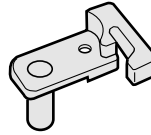
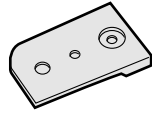
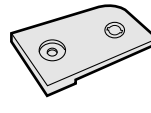
★ Select the same color as the refrigerator exterior.

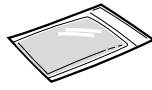
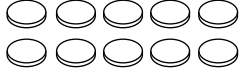
			★ 	★ 
A Bottom hinge L	B Stopper spring L (for upper door)	C Stopper spring L (for lower door)	D Door cap cover (for upper door)	E Door cap cover (for lower door)
★ 			★ 	
F Door hole cover	G Screw and Cover	H Silicon grease	J Screw cap for handle (Spare)	

Tools required

- Phillips and slotted screwdrivers
- Drill bit (ø 3.8 mm)
- Socket wrench or spanner (8 mm) :The socket wrench or spanner is used to detach and attach hinges.

Caution

- **Always disconnect the power plug from the wall outlet before performing work.**
- **Caution should be taken when handling the doors.**
These are heavy and could cause personal injury if mishandled.
- **Always tighten screws securely. May cause personal injury if door becomes unlatched and falls.**
- **Reattach doors paying careful attention to the door alignment. Failure to fit the door correctly might cause the cool air to leak out and lower the cooling performance.**

Fitting Instruction

1 Preparation/Removing Doors

1. Remove Evaporating pan cover, Upper hinge cover, and Top cover.
(Carefully remove Upper hinge cover using a screwdriver, making sure that the door is not damaged.)
2. Remove Upper hinge and Spacer, and detach Upper door by lifting off the center hinge.
3. Remove Center hinge and detach Lower door by lifting off the bottom hinge. Remove the 2 Hole caps, replace them on the screw holes of the removed center hinge, then screw in **G** (screw and cover) in the center hole.
4. Remove Bottom hinge. Remove the 3 screws on the left side, then install them in the screw holes of Bottom hinge.

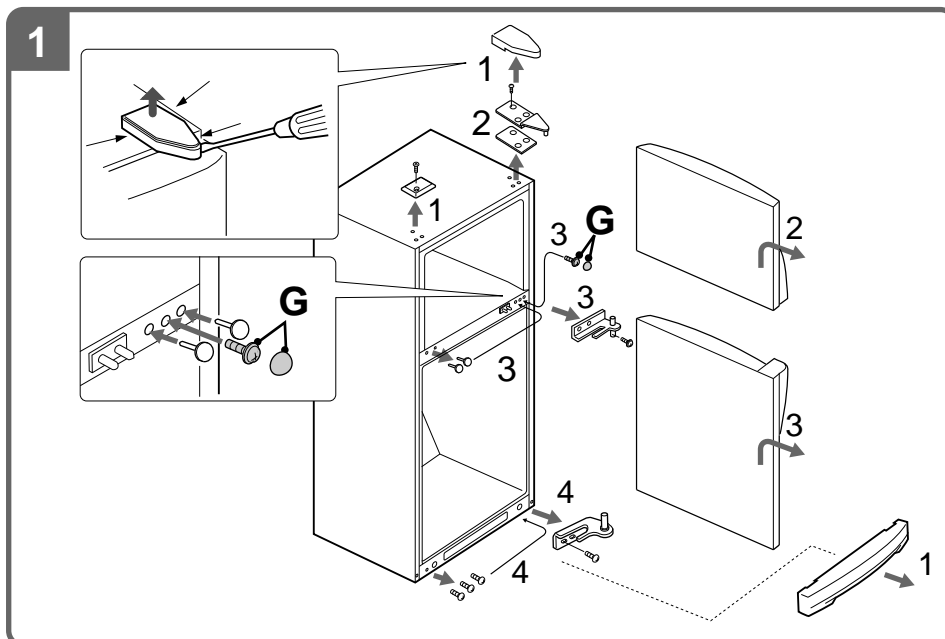

Figure M-1

2 Replacing Handles and Door Parts

1. Remove Screw caps and Screws on each door handle, then remove the handles.
 Flatten the surface of the screw holes using the handle of a screwdriver, etc., then mount 3 units of **F** (Door hole covers) on each door.
2. Remove the Nylon bearings, Door stopper(Lower door only), Stopper springs on the right side of each door and the cap on the left side of the Upper door. Furthermore, open the hidden holes on the bottom of the door using a screwdriver, then remove a screw (Lower door only).
3. Remove Screw caps and Screws on the right side of each door, then remove the Door cap covers and mount **D** and **E** (Door cap covers) on the left side.
4. Replace Nylon bearings to the left side of each door, then mount the Upper door cap on the right side. Furthermore, mount Door stopper and **B** and **C**(Stopper springs) on the left side as well. Screw in a screw in the screw hole on the lower right of the Lower door.
5. Fix upper portion of Upper handle using one screw on the right side of Lower door, then temporarily fix the handle to the door using tape.
6. To open screw holes, first make marks on the doorplate surface through the 3 holes of the handle, then temporarily remove the handle (make sure that the dimensions of the markings are as shown in the diagram).
 - Use a drill guide, etc., to prevent the drill bit from entering more than 5 mm.
 - Make sure to open the hole straight. Opening the hole in an angle will cause the handle to clatter.**The door will be unusable if the hole are too large or too deep or if the screws are tightened too much.**
8. Mount the handle using the 4 screws and install Screw caps.
9. Mount Lower handle on the right side of Upper door by repeating steps 5. ~ 8. above.

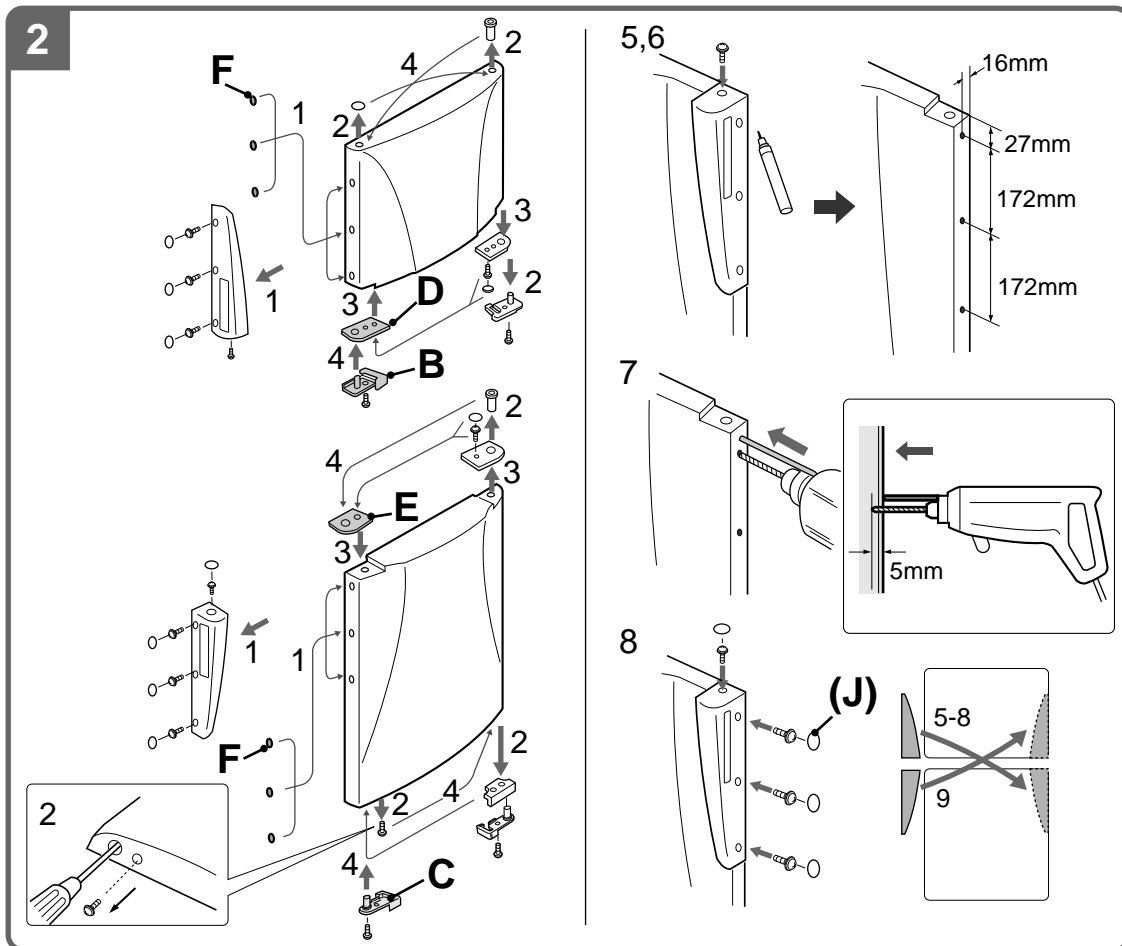



Figure M-2

3 Mounting the Door/Finishing

1. Apply Silicon grease **H** to the shaded portion  of part **A**(Bottom hinge L) and attach it to the left side.
2. Insert Lower door and fit Center hinge vertically inverted. Remove washer if installed. Tighten the screws temporarily.
3. Fit Upper door and attach Upper hinge together with spacer. Tighten the screws temporarily.
4. Adjust the alignment of the door. Ensure that the gap between the cabinet and door is 12 mm. Tighten the upper hinge screws.
5. Secure Upper door. Open Lower door and tighten the center hinge screws. (No drawing)
6. Check the following. To readjust the door position, loosen Center and Bottom hinges.
 - Whether the distance to activate the door switch is correct.
 - Whether each door can be opened/closed smoothly.
 - Whether each door is properly sealed when closed. (Check by inserting a sheet of paper between the door and cabinet when closing. The refrigerator is not properly sealed if the paper falls.)
7. Apply Silicon grease **H** to the shaded portion  of the door packing.
8. Replace the cap in Evaporating pan cover on the right side.
9. Reattach Evaporating pan cover, Upper hinge cover and Top cover.
10. Make sure that each door can be opened and closed normally. (If any of the doors cannot open/closes normally, tilt the refrigerator slightly backward by screwing out the two adjustable feet.) Furthermore, connect the power plug, make sure that cold air is not leaking from the door packing, and that the cabinet lamp operates properly when the door is opened/closed.

※ Retain removed parts in case doors are to be changed back to right opening.

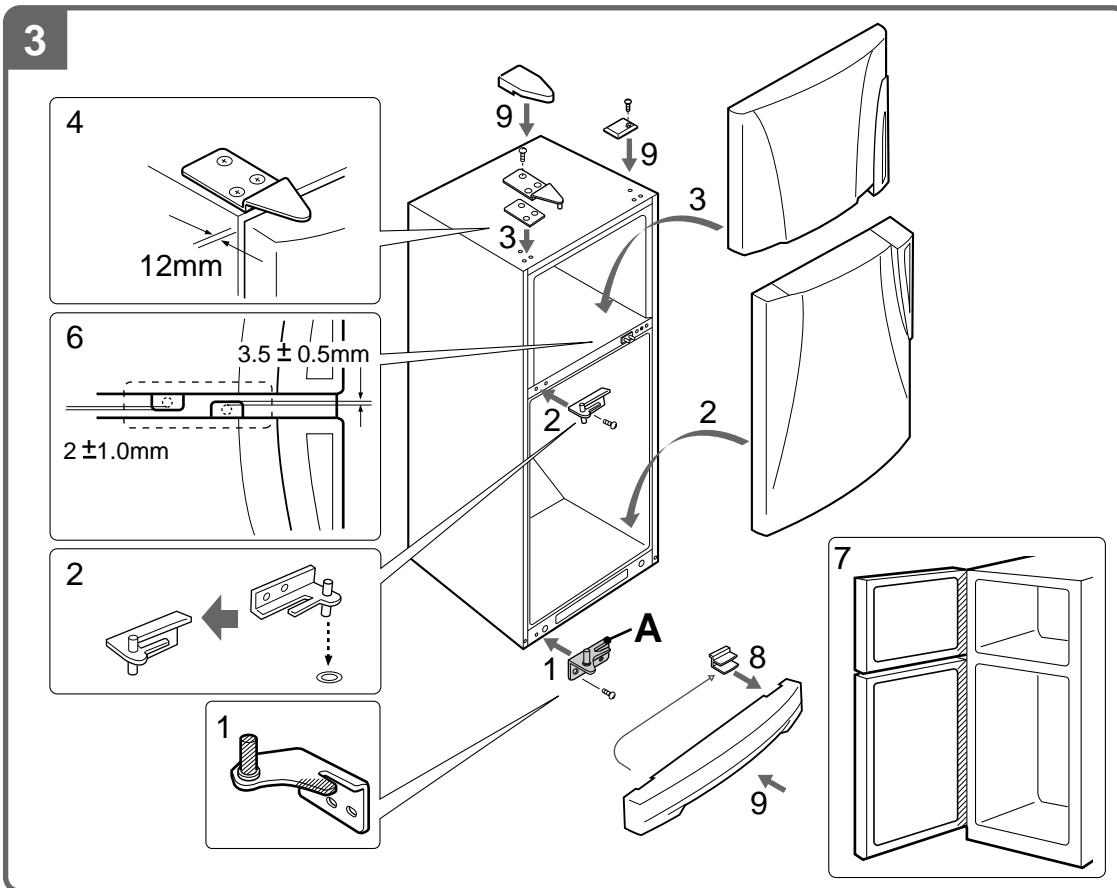

Figure M-3

COOLING UNIT

→ Mark: Refrigerant flow
× Mark: Brazing portion

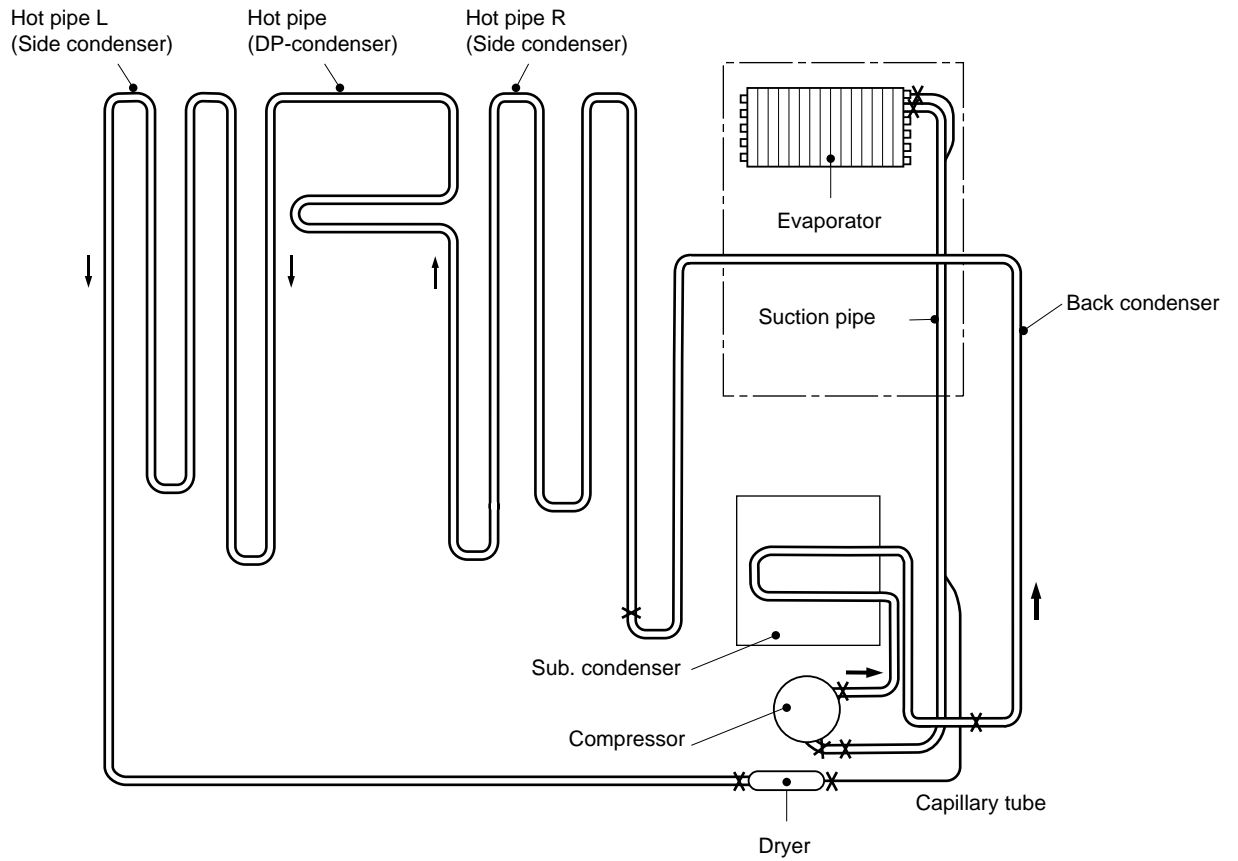

Figure C-1. Cooling unit

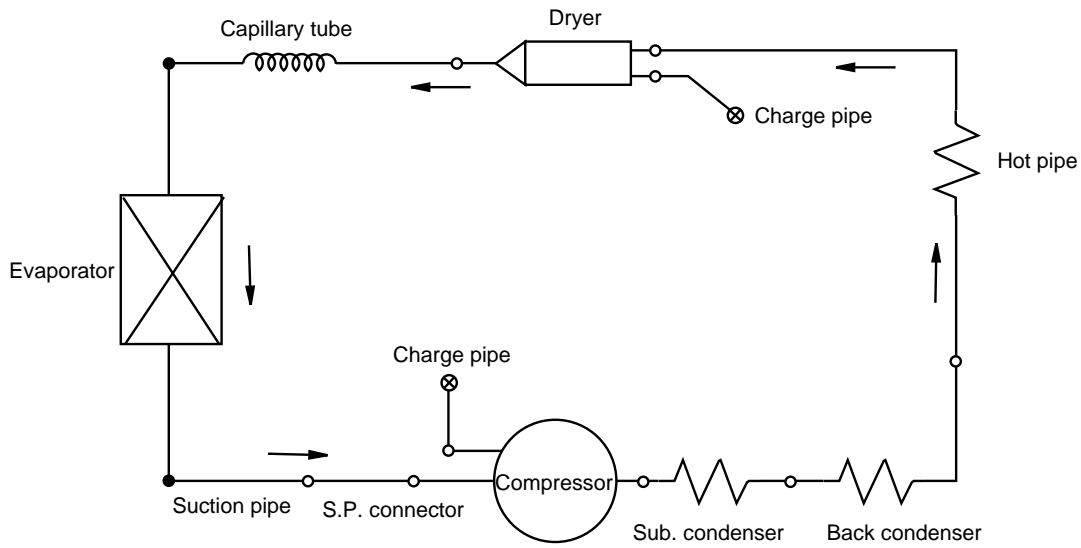

Figure C-2. Location

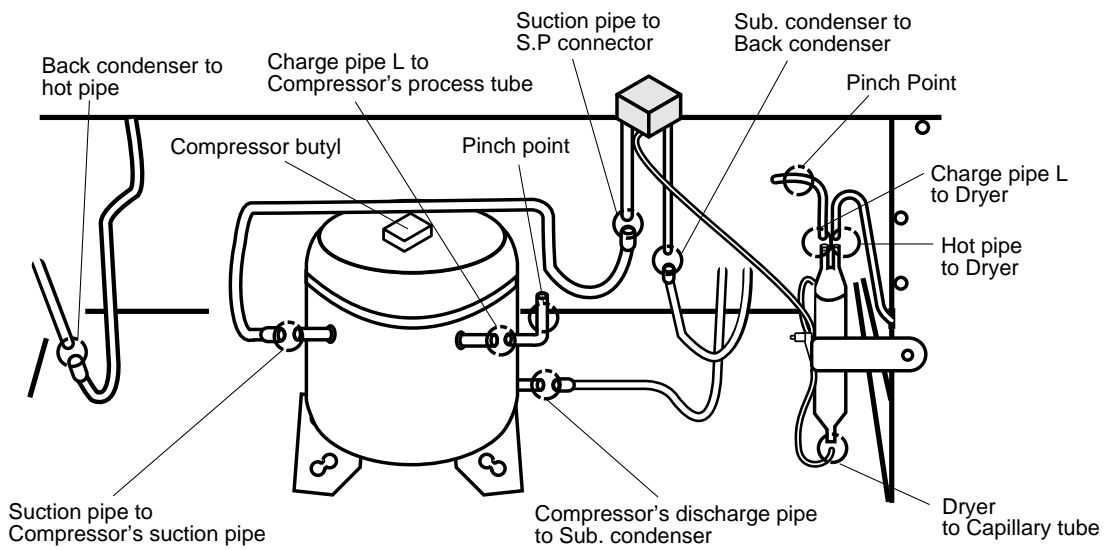

Figure C-3. Location

SHARP SERVICE MANUAL

REPLACEMENT PARTS LIST

MODELS

SJ-58L-A2G/A2B/A2L/A2A

SJ-63L-A2G/A2B/A2L/A2A

SJ-68L-A2G/A2B/A2L/A2A

DESTINATION R

REPLACEMENT PARTS LIST(SJ-58L-A2G/A2B/A2L/A2A)

REF. NO.	PART NO.	DESCRIPTION	Q'TY				CODE
			SJ-58L -A2G	SJ-58L -A2B	SJ-58L -A2L	SJ-58L -A2A	

ELECTRIC PARTS

1-1	RTHM-A097CBEZ	F-thermostat	1	1	1	1	AX
1-2	RSTT-A144CBE0	Starting relay	1	1	1	1	AW
1-3	QSWTDA035CBE0	Defrost timer	1	1	1	1	BB
1-4	PDMP-A046CBEZ	Damper thermo	1	1	1	1	AX
1-5	FTHM-A028CBKZ	Defrost thermo.assembly	1	1	1	1	AN
1-6	RMOTRA040CBE0	Fan motor	1	1	1	1	AZ
1-7	QSOCAA074CBEZ	Lamp socket	1	1	1	1	AP
1-8	RLMP-A012CBE0	Lamp	1	1	1	1	AH
1-9	QACC-A096CBE0	Source cord	1	1	1	1	AX
1-10	QSW-PA090CBZA	Door switch	1	1	1	1	AS
1-11	RHOG-A084CBE0	Protector	1	1	1	1	AN
1-17	FFS-TA055CBKZ	Fuse assembly	1	1	1	1	AL
1-20	FW-VZA144CBEZ	Lead ev-cover assembly	1	1	1	1	AK
1-21	FHETBA149CBEZ	Def.heater assembly	1	1	1	1	BB
1-22	FCNW-A517CBK0	Relay cord s assembly	1	1	1	1	AM
1-25	QTAN-A032CBE0	Terminal block	1	1	1	1	AE
1-27	RMOTRA061CBEZ	Fan motor	1	1	1	1	AW
1-28	RLMP-A029CBEZ	Lamp15W	1	1	1	1	AH
1-29	QSOCAA072CBEZ	Lamp socket	1	1	1	1	AN
1-30	FTHM-A029CBKZ	R fan thermo assembly	1	1	1	1	AQ

MECHANICAL PARTS

2-2	JKNB-A036CBFB	F-temp. control knob	1	1	1	1	AD
2-4	LPLTMA568CBEZ	Fl plate AL.	1	1	1	1	AF
2-7	FLEGPA077CBKZ	Leg holder L assembly	1	1	1	1	AQ
2-7-1	FAJS-A009CBK0	Adjustable leg assembly	2	2	2	2	AD
2-7-2	LHLD-A533CBPZ	Leg holder L	1	1	1	1	AL
2-8	FLEGPA078CBKZ	Leg holder R assembly	1	1	1	1	AQ
2-8-2	LHLD-A534CBPZ	Leg holder R	1	1	1	1	AP
2-10	PSPAVA083CBEA	Upper hinge spacer	1	1	1	1	AD
2-11	PSPAVA084CBEA	Bottom hinge spacer	1	1	1	1	AC
2-12	PSPAVA075CBEA	Center hinge spacer	1	1	1	1	AD
2-13	DHNG-A363CBMZ	Upper hinge assembly	1	1	1	1	AE
2-14	DHNG-A365CBMZ	Bottom hinge R assembly	1	1	1	1	AE
2-15	DHNG-A364CBMZ	Center hinge R assembly	1	1	1	1	AF
2-16	GCOV-A191CBFZ	E.V cover	1	1	1	1	AS
2-17	LCRA-A010CBE0	Fan clamp	2	2	2	2	AD
2-19	LHLD-A389CBF0	Motor cushion	2	2	2	2	AF
2-20	NFANPA020CBFA	Propeller fan 100	1	1	1	1	AE
2-21	PSEL-B845CBEZ	E.V cover sealer A	1	1	1	1	AC
2-22	PSEL-B846CBEZ	E.V cover sealer B	1	1	1	1	AC
2-23	PSEL-A415CBE0	E.V cover sealer C	1	1	1	1	AC
2-24	PCOVPA164CBFA	Terminal cover	1	1	1	1	AE
2-25	PCOV-A253CBFA	F lamp cover	1	1	1	1	AC
2-26	PCOV-A254CBFA	R lamp cover	1	1	1	1	AF
2-27	GCOVPA119CBRA	R-Cbox cover	1	1	1	1	AS
2-28	HGRL-A184CBRA	Fan louver	1	1	1	1	AU
2-29	GCOV-A162CBFB	Upper hinge cover	-	1	-	-	AD
2-29	GCOV-A162CBFG	Upper hinge cover	1	-	-	-	AD
2-29	GCOV-A162CBFH	Upper hinge cover	-	-	-	1	AD
2-29	GCOV-A162CBFK	Upper hinge cover	-	-	1	-	AD
2-30	PCOV-A255CBFA	Fan cover	2	2	2	2	AD
2-31	JKNB-A033CBFB	R-temp.control knob	1	1	1	1	AD
2-36	PCAP-A006CBFS	Screw cover	-	2	-	-	AB
2-36	PCAP-A006CBFU	Screw cover	-	-	2	-	AB
2-36	PCAP-A006CBFX	Screw cover	2	-	-	-	AB
2-36	PCAP-A006CBFY	Screw cover	-	-	-	2	AB
2-37	PCAP-A056CBFF	Screw cover B	2	2	2	2	AC
2-38	PGID-A156CBFZ	R air guider A	1	1	1	1	AG
2-41	PSEL-B848CBEZ	A-sealer thermo.cap	1	1	1	1	AC
2-49	LSTPPA108CBFA	Chilled stopper	2	2	2	2	AC
2-50	NFANPA019CBFA	Propeller fan 80	1	1	1	1	AM
2-51	PBOX-A121CBFA	F lamp box	1	1	1	1	AF
2-52	PBOX-A122CBFA	R lamp box	1	1	1	1	AM
2-53	LHLD-A536CBFA	R fan motor holder A	1	1	1	1	AF
2-54	LHLD-A537CBFA	R fan motor holder B	1	1	1	1	AE
2-55	HGRL-A188CBFA	Multi louver S	1	1	1	1	AG
2-56	PFPFPB248CBFZ	R-louver insu. S	1	1	1	1	AE
2-57	PSEL-B861CBEZ	A-sealer r-louver	2	2	2	2	AC
2-59	PCOV-A264CBEZ	F lamp box cover	1	1	1	1	AC
2-63	LHLD-A484CBFA	Fan motor holder B	1	1	1	1	AH
2-64	LHLD-A485CBFA	Fan motor holder A	1	1	1	1	AH
2-65	PSEL-B209CBE0	U-sealer handle	2	2	2	2	AB
2-66	PSHEMA132CBP0	Heater cover AL	1	1	1	1	AD

REF. NO.	PART NO.	DESCRIPTION	Q'TY				CODE
			SJ-58L -A2G	SJ-58L -A2B	SJ-58L -A2L	SJ-58L -A2A	
2-67	LPLTMA570CBPZ	Drain support AL	1	1	1	1	AE
2-69	PSEL-B847CBEZ	E.V cover sealer D	2	2	2	2	AC
2-71	PSEL-A552CBE0	Dial sealer	1	1	1	1	AC
2-72	PSEL-B841CBEZ	Ra sealer A	2	2	2	2	AC
2-73	PSEL-B842CBEZ	Ra sealer B	1	1	1	1	AC
2-74	PSEL-B122CBE0	A-sealer thermo.cap.	1	1	1	1	AB
2-77	LHLD-A391CBE0	Sl-5N clip	1	1	1	1	AD
2-78	LPLTMA399CBP0	Dryer support	1	1	1	1	AD
2-79	LBND-A019CBE0	Nylon band	1	1	1	1	AB
2-80	PBOX-A071CBFA	Terminal box	1	1	1	1	AE
2-81	PPIPPA097CBEZ	Drain pipe S	1	1	1	1	AE
2-83	PSEL-B849CBEZ	Ra sealer C	1	1	1	1	AC
2-84	PSEL-B850CBEZ	Ra sealer D	1	1	1	1	AC
2-86	LBND-A026CBE0	Nylon band	1	1	1	1	AD
2-87	LBND-A018CBE0	Fasting band A	1	1	1	1	AP
2-90	HGRL-A179CBFA	F shower duct	1	1	1	1	AM
2-91	HGRL-A180CBFA	F return cover	2	2	2	2	AC
2-93	PCAP-A068CBFA	C sliding cap A	2	2	2	2	AC
2-95	NROL-A027CBEZ	V roller	2	2	2	2	AC
2-96	LHLD-A535CBFA	Shaft holder	2	2	2	2	AC
2-97	LPIN-A178CB1Z	Shaft	2	2	2	2	AC
2-99	GCOV-A192CBFA	Top cover	1	-	-	-	AC
2-99	GCOV-A192CBFB	Top cover	-	1	-	-	AK
2-99	GCOV-A192CBFC	Top cover	-	-	-	1	AD
2-99	GCOV-A192CBFF	Top cover	-	-	1	-	AC
2-105	PSEL-B896CBEZ	A-sealer FS-A	1	1	1	1	AC
2-106	PSEL-B897CBEZ	A-sealer FS-B	2	2	2	2	AC

DOOR PARTS

3-5	FDORFB299CBKZ	F-door assembly	1	-	-	-	BK
3-5	FDORFB306CBKZ	F-door assembly	-	1	-	-	BM
3-5	FDORFB307CBKZ	F-door assembly	-	-	-	1	BK
3-5	FDORFB313CBKZ	F-door assembly	-	-	1	-	BL
3-5-1	LSTPPA107CBFA	Fd stopper spring R	1	1	1	1	AD
3-5-2	NBRGPA022CBFA	Nylon bearing 3S	2	2	2	2	AC
3-5-3	PCOV-A251CBFA	Dc cover FR	1	-	-	-	AC
3-5-3	PCOV-A251CBFB	Dc cover FR	-	1	-	-	AC
3-5-3	PCOV-A251CBFC	Dc cover FR	-	-	-	1	AC
3-5-3	PCOV-A251CBFF	Dc cover FR	-	-	1	-	AC
3-6	FPACGA309CBKZ	F-door packing	1	1	1	1	AX
3-7	HDECQA384CBFA	Handle trim FL	1	1	1	-	AD
3-7	HDECQA384CBFB	Handle trim FL	-	-	-	1	AG
3-8	JHNDPA117CBFA	Door handle FL	1	-	-	-	AK
3-8	JHNDPA117CBFB	Door handle FL	-	1	-	-	AM
3-8	JHNDPA117CBFC	Door handle FL	-	-	-	1	AN
3-8	JHNDPA117CBFF	Door handle FL	-	-	1	-	AP
3-9	PCAP-A067CBFA	Screw cover HD	10	-	-	-	AC
3-9	PCAP-A067CBFB	Screw cover HD	-	10	-	-	AC
3-9	PCAP-A067CBFC	Screw cover HD	-	-	-	10	AD
3-9	PCAP-A067CBFF	Screw cover HD	-	-	10	-	AC
3-15	FDORRB181CBKZ	R-door assembly	1	-	-	-	BP
3-15	FDORRB183CBKZ	R-door assembly	-	1	-	-	BP
3-15	FDORRB184CBKZ	R-door assembly	-	-	-	1	BN
3-15	FDORRB189CBKZ	R-door assembly	-	-	1	-	BN
3-15-1	LSTP-A058CBM0	R-door stopper R	1	1	1	1	AF
3-15-2	LSTPPA084CBFA	Rd-stopper spring R	1	1	1	1	AD
3-15-3	PCOV-A252CBFA	Dc cover RR	1	-	-	-	AC
3-15-3	PCOV-A252CBFB	Dc cover RR	-	1	-	-	AC
3-15-3	PCOV-A252CBFC	Dc cover RR	-	-	-	1	AC
3-15-3	PCOV-A252CBFF	Dc cover RR	-	-	1	-	AC
3-17	FPACGA315CBKZ	R-door packing	1	1	1	1	AY
3-18	HDECQA385CBFA	Handle trim RL	1	1	1	-	AG
3-18	HDECQA385CBFB	Handle trim RL	-	-	-	1	AG
3-19	JHNDPA118CBFA	Door handle RL	1	-	-	-	AK
3-19	JHNDPA118CBFB	Door handle RL	-	1	-	-	AM
3-19	JHNDPA118CBFC	Door handle RL	-	-	-	1	AN
3-19	JHNDPA118CBFF	Door handle RL	-	-	1	-	AP
3-25	FBDGDA280CBYZ	Badge assembly	1	1	1	1	AY

OTHER PARTS

4-1	LBND-A023CBE0	L-band C	4	4	4	4	AC
4-3	LX-VZA003CBE0	Special screw	2	2	2	2	AB
4-10	QTAN-A013CBE0	Solderless term. A	4	4	4	4	AH
4-15	LX-BZA018CBE0	Special screw	1	1	1	1	AA
4-17	LX-WZA003CBE0	Washer	4	4	4	4	AA
4-18	LX-BZA076CBEZ	Handle screw	10	10	10	10	AC

REF. NO.	PART NO.	DESCRIPTION	Q'TY				CODE
			SJ-58L -A2G	SJ-58L -A2B	SJ-58L -A2L	SJ-58L -A2A	

ATTACHMENT PARTS

5-1	UPOK-A166CBRA	Bottle pocket	2	2	2	2	AN
5-3	UPOK-A168CBRA	F door pocket	2	2	2	2	AP
5-4	UPOK-A165CBRA	R door pocket	1	1	1	1	AN
5-5	UTNA-A282CBFB	Egg tray	2	2	2	2	AG
5-6	FSRA-A193CBYZ	Ice cube maker	1	1	1	1	AS
5-9	FSRA-A194CBKZ	F shelf assembly	1	1	1	1	AY
5-13	HGRL-A178CBFA	Ventilating grille	1	-	-	-	AG
5-13	HGRL-A178CBFB	Ventilating grille	-	1	-	-	AM
5-13	HGRL-A178CBFC	Ventilating grille	-	-	-	1	AN
5-13	HGRL-A178CBFF	Ventilating grille	-	-	1	-	AN
5-14	USRA-A252CBFA	Drain pan	1	1	1	1	AN
5-15	UYOK-A330CBFA	Fruit case	1	1	1	1	AW
5-16	UYOK-A331CBFA	Vegetable case	1	1	1	1	AZ
5-17	UYOK-A328CBFA	Ice storage box	1	1	1	1	AF
5-18	UYOK-A329CBFA	Chilled case	1	1	1	1	AX
5-19	GDORPA066CBRA	Chilled door	1	1	1	1	AP
5-24	FTNA-A301CBKZ	R glass shelf assembly	2	2	2	2	BC
5-25	FTNA-A302CBKZ	V glass shelf assembly	1	1	1	1	BC
5-26	PCAP-A076CBFA	Venti.grille cap	1	-	-	-	AC
5-26	PCAP-A076CBFB	Venti.grille cap	-	1	-	-	AC
5-26	PCAP-A076CBFC	Venti.grille cap	-	-	-	1	AD
5-26	PCAP-A076CBFF	Venti.grille cap	-	-	1	-	AC
5-28	PCAP-A069CBFA	V sliding cap L	1	1	1	1	AC
5-29	PCAP-A070CBFA	V sliding cap R	1	1	1	1	AC
5-31	LRALPA132CBFA	Ice tray holder L	1	1	1	1	AF
5-32	LRALPA133CBFA	Ice tray holder R	1	1	1	1	AF
5-33	LRALPA134CBFA	Ice tray holder B	1	1	1	1	AF
5-34	PCUP-A009CBFA	Water cup	1	1	1	1	AD
5-35	UPOKPA251CBFA	Tube stand	2	2	2	2	AC
5-36	PCOV-A259CBFA	Case cover	1	1	1	1	AH
5-37	UPOK-A167CBRA	Utility case pocket	1	1	1	1	AM

CYCLE PARTS

6-1	PCMPLA196CBE0	Compressor	1	1	1	1	BX
6-2	PSPAGA028CBE0	Rubber grommet	4	4	4	4	AD
6-3	FCONSA077CBKZ	Sub. condenser assembly	1	1	1	1	AX
6-3-1	PCOV-A256CBFA	Pipe protector L	1	1	1	1	AF
6-3-2	PCOV-A257CBFA	Pipe protector R	1	1	1	1	AF
6-4	FFRM-A113CBKZ	Base frame assembly	1	1	1	1	AW
6-5	FDRY-A006CBK0	Dryer assembly	1	1	1	1	AX
6-6	PCLI-A035CBE0	Clip	1	1	1	1	AC
6-9	PSPAFA020CBE0	Sleeve	4	4	4	4	AB
6-11	PPIPCA357CBEZ	S.p connector	1	1	1	1	AK
6-15	PGUM-A002CBF0	Absorbent rubber B	1	1	1	1	AH
6-18	PPIPCA252CBE0	Charge pipe	2	2	2	2	AD
6-21	PCOVPA165CBE0	Terminal cover	1	1	1	1	AF
6-27	PSEL-B899CBEZ	S-sealer	2	2	2	2	AC
6-28	PKYU-A143CBEZ	S-butyl	1	1	1	1	AD
6-29	PKYU-A036CBE0	Sp-butyl d-poy	1	1	1	1	AP
6-30	PKYU-A098CBE0	Compressor butyl	1	1	1	1	AG

MISCELLANEOUS

90-1	TINS-A491CBRZ	Operation manual	1	1	1	1	AF
90-2	TLAB-A092CBR0	Lamp label	1	1	1	1	AD
90-3	SPAKCI800YDEZ	Packing case 58L	1	1	1	1	BB
90-5	TLAB-A897CBEZ	Case label A2G	4	-	-	-	AC
90-5	TLAB-A916CBEZ	Case label A2B	-	4	-	-	AC
90-5	TLAB-A927CBEZ	Case label A2L	-	-	4	-	AC
90-5	TLAB-A937CBEZ	Case label A2A	-	-	-	4	AB
90-6	CPADBA765YDKZ	Bottom pad assembly	1	1	1	1	AY
90-7	CPADBA764YDKZ	Top pad assembly	1	1	1	1	AR
90-8	TLAB-A876CBRZ	Warning label	1	1	1	1	AC
90-21	TLAB-A939CBRZ	Caution label ROF	1	1	1	1	AD

HOW TO ORDER REPLACEMENT PARTS

To have your order filled promptly and correctly, please furnish the following information.

1. MODEL NUMBER
2. REF. NO.
3. PART NO.
4. DESCRIPTION

REPLACEMENT PARTS LIST(SJ-63L-A2G/A2B/A2L/A2A)

REF. NO.	PART NO.	DESCRIPTION	Q'TY				CODE
			SJ-63L -A2G	SJ-63L -A2B	SJ-63L -A2L	SJ-63L -A2A	

ELECTRIC PARTS

1-1	RTHM-A097CBEZ	F-thermostat	1	1	1	1	AX
1-2	RSTT-A144CBE0	Starting relay	1	1	1	1	AW
1-3	QSWTDA035CBE0	Defrost timer	1	1	1	1	BB
1-4	PDMP-A046CBEZ	Damper thermo	1	1	1	1	AX
1-5	FTHM-A028CBKZ	Defrost thermo.assembly	1	1	1	1	AN
1-6	RMOTRA040CBE0	Fan motor	1	1	1	1	AZ
1-7	QSOCAA074CBEZ	Lamp socket	1	1	1	1	AP
1-8	RLMP-A012CBE0	Lamp	1	1	1	1	AH
1-9	QACC-A096CBE0	Source cord	1	1	1	1	AX
1-10	QSW-PA090CBZA	Door switch	1	1	1	1	AS
1-11	RHOG-A084CBE0	Protector	1	1	1	1	AN
1-17	FFS-TA055CBKZ	Fuse assembly	1	1	1	1	AL
1-20	FW-VZA144CBEZ	Lead ev-cover assembly	1	1	1	1	AK
1-21	FHETBA149CBEZ	Def.heater assembly	1	1	1	1	BB
1-22	FCNW-A517CBK0	Relay cord s assembly	1	1	1	1	AM
1-25	QTAN-A032CBE0	Terminal block	1	1	1	1	AE
1-27	RMOTRA061CBEZ	Fan motor	1	1	1	1	AW
1-28	RLMP-A029CBEZ	Lamp 15W	1	1	1	1	AH
1-29	QSOCAA072CBEZ	Lamp socket	1	1	1	1	AN
1-30	FTHM-A029CBKZ	R fan thermo assembly	1	1	1	1	AQ

MECHANICAL PARTS

2-2	JKNB-A036CBFB	F-temp. control knob	1	1	1	1	AD
2-4	LPLTMA568CBEZ	F1 plate AL.	1	1	1	1	AF
2-7	FLEGPA077CBKZ	Leg holder L assembly	1	1	1	1	AQ
2-7-1	FAJS-A009CBK0	Adjustable leg assembly	2	2	2	2	AD
2-7-2	LHLD-A533CBPZ	Leg holder L	1	1	1	1	AC
2-8	FLEGPA078CBKZ	Leg holder R assembly	1	1	1	1	AQ
2-8-2	LHLD-A534CBPZ	Leg holder R	1	1	1	1	AP
2-10	PSPAVA083CBEA	Upper hinge spacer	1	1	1	1	AD
2-11	PSPAVA084CBEA	Bottom hinge spacer	1	1	1	1	AC
2-12	PSPAVA075CBEA	Center hinge spacer	1	1	1	1	AD
2-13	DHNG-A363CBMZ	Upper hinge assembly	1	1	1	1	AE
2-14	DHNG-A365CBMZ	Bottom hinge R assembly	1	1	1	1	AE
2-15	DHNG-A364CBMZ	Center hinge R assembly	1	1	1	1	AF
2-16	GCOV-A191CBFZ	E.V cover	1	1	1	1	AS
2-17	LCRA-A010CBE0	Fan clamp	2	2	2	2	AD
2-19	LHLD-A389CBF0	Motor cushion	2	2	2	2	AF
2-20	NFANPA020CBFA	Propeller fan 100	1	1	1	1	AE
2-21	PSEL-B845CBEZ	E.V cover sealer A	1	1	1	1	AC
2-22	PSEL-B846CBEZ	E.V cover sealer B	1	1	1	1	AC
2-23	PSEL-A415CBE0	E.V cover sealer C	1	1	1	1	AC
2-24	PCOVPA164CBFA	Terminal cover	1	1	1	1	AE
2-25	PCOV-A253CBFA	F lamp cover	1	1	1	1	AC
2-26	PCOV-A254CBFA	R lamp cover	1	1	1	1	AF
2-27	GCOVPA119CBRA	R-cbox cover	1	1	1	1	AS
2-28	HGRL-A184CBRA	Fan louver	1	1	1	1	AU
2-29	GCOV-A162CBFB	Upper hinge cover	-	1	-	-	AD
2-29	GCOV-A162CBFG	Upper hinge cover	1	-	-	-	AD
2-29	GCOV-A162CBFH	Upper hinge cover	-	-	-	1	AD
2-29	GCOV-A162CBFK	Upper hinge cover	-	-	1	-	AD
2-30	PCOV-A255CBFA	Fan cover	2	2	2	2	AD
2-31	JKNB-A033CBFB	R-temp.control knob	1	1	1	1	AD
2-36	PCAP-A006CBFS	Screw cover	-	2	-	-	AB
2-36	PCAP-A006CBFU	Screw cover	-	-	2	-	AB
2-36	PCAP-A006CBFX	Screw cover	2	-	-	-	AB
2-36	PCAP-A006CBFY	Screw cover	-	-	-	2	AB
2-37	PCAP-A056CBFF	Screw cover B	2	2	2	2	AC
2-38	PGID-A156CBFZ	R air guider A	1	1	1	1	AG
2-41	PSEL-B848CBEZ	A-sealer thermo.cap	1	1	1	1	AC
2-49	LSTPPA108CBFA	Chilled stopper	2	2	2	2	AC
2-50	NFANPA019CBFA	Propeller fan 80	1	1	1	1	AM
2-51	PBOX-A121CBFA	F lamp box	1	1	1	1	AF
2-52	PBOX-A122CBFA	R lamp box	1	1	1	1	AM
2-53	LHLD-A536CBFA	R fan motor holder A	1	1	1	1	AF
2-54	LHLD-A537CBFA	R fan motor holder B	1	1	1	1	AE
2-55	HGRL-A186CBFA	Multi louver M	1	1	1	1	AM
2-56	PFPFPB239CBFZ	R-louver insu. M	1	1	1	1	AF
2-57	PSEL-B857CBEZ	A-sealer R-louver	2	2	2	2	AC
2-59	PCOV-A264CBEZ	F lamp box cover	1	1	1	1	AC
2-63	LHLD-A484CBFA	Fan motor holder B	1	1	1	1	AH
2-64	LHLD-A485CBFA	Fan motor holder A	1	1	1	1	AH
2-65	PSEL-B209CBE0	U-sealer handle	2	2	2	2	AB
2-66	PSHEMA132CBP0	Heater cover AL	1	1	1	1	AD

REF. NO.	PART NO.	DESCRIPTION	Q'TY				CODE
			SJ-63L -A2G	SJ-63L -A2B	SJ-63L -A2L	SJ-63L -A2A	
2-67	LPLTMA570CBPZ	Drain support AL	1	1	1	1	AE
2-69	PSEL-B847CBEZ	E.V cover sealer D	2	2	2	2	AC
2-71	PSEL-A552CBE0	Dial sealer	1	1	1	1	AC
2-72	PSEL-B841CBEZ	Ra sealer A	2	2	2	2	AC
2-73	PSEL-B842CBEZ	Ra sealer B	1	1	1	1	AC
2-74	PSEL-B122CBE0	A-sealer thermo.cap.	1	1	1	1	AB
2-77	LHLD-A391CBE0	Sl-5N clip	1	1	1	1	AD
2-78	LPLTMA399CBP0	Dryer support	1	1	1	1	AD
2-79	LBND-A019CBE0	Nylon band	1	1	1	1	AB
2-80	PBOX-A071CBFA	Terminal box	1	1	1	1	AE
2-81	PPIPPA097CBEZ	Drain pipe S	1	1	1	1	AE
2-83	PSEL-B849CBEZ	RA sealer C	1	1	1	1	AC
2-84	PSEL-B850CBEZ	RA sealer D	1	1	1	1	AC
2-86	LBND-A026CBE0	Nylon band	1	1	1	1	AD
2-87	LBND-A018CBE0	Fasting band A	1	1	1	1	AP
2-90	HGRL-A179CBFA	F shower duct	1	1	1	1	AM
2-91	HGRL-A180CBFA	F return cover	2	2	2	2	AC
2-93	PCAP-A068CBFA	C sliding cap A	2	2	2	2	AC
2-95	NROL-A027CBEZ	V roller	2	2	2	2	AC
2-96	LHLD-A535CBFA	Shaft holder	2	2	2	2	AC
2-97	LPIN-A178CB1Z	Shaft	2	2	2	2	AC
2-99	GCOV-A192CBFA	Top cover	1	-	-	-	AC
2-99	GCOV-A192CBFB	Top cover	-	1	-	-	AK
2-99	GCOV-A192CBFC	Top cover	-	-	-	1	AD
2-99	GCOV-A192CBFF	Top cover	-	-	1	-	AC
2-105	PSEL-B896CBEZ	A-sealer FS-A	1	1	1	1	AC
2-106	PSEL-B897CBEZ	A-sealer FS-B	2	2	2	2	AC

DOOR PARTS

3-5	FDORFB299CBKZ	F-door assembly	1	-	-	-	BK
3-5	FDORFB306CBKZ	F-door assembly	-	1	-	-	BM
3-5	FDORFB307CBKZ	F-door assembly	-	-	-	1	BK
3-5	FDORFB313CBKZ	F-door assembly	-	-	1	-	BL
3-5-1	LSTPPA107CBFA	Fd stopper spring R	1	1	1	1	AD
3-5-2	NBRGPA022CBFA	Nylon bearing 3S	2	2	2	2	AC
3-5-3	PCOV-A251CBFA	Dc cover FR	1	-	-	-	AC
3-5-3	PCOV-A251CBFB	Dc cover FR	-	1	-	-	AC
3-5-3	PCOV-A251CBFC	Dc cover FR	-	-	-	1	AC
3-5-3	PCOV-A251CBFF	Dc cover FR	-	-	1	-	AC
3-6	FPACGA309CBKZ	F-door packing	1	1	1	1	AX
3-7	HDECQA384CBFA	Handle trim FL	1	1	1	-	AD
3-7	HDECQA384CBFB	Handle trim FL	-	-	-	1	AG
3-8	JHNDPA117CBFA	Door handle FL	1	-	-	-	AK
3-8	JHNDPA117CBFB	Door handle FL	-	1	-	-	AM
3-8	JHNDPA117CBFC	Door handle FL	-	-	-	1	AN
3-8	JHNDPA117CBFF	Door handle FL	-	-	1	-	AP
3-9	PCAP-A067CBFA	Screw cover HD	10	-	-	-	AC
3-9	PCAP-A067CBFB	Screw cover HD	-	10	-	-	AC
3-9	PCAP-A067CBFC	Screw cover HD	-	-	-	10	AD
3-9	PCAP-A067CBFF	Screw cover HD	-	-	10	-	AC
3-15	FDORRB173CBKZ	R-door assembly	1	-	-	-	BQ
3-15	FDORRB174CBKZ	R-door assembly	-	1	-	-	BQ
3-15	FDORRB176CBKZ	R-door assembly	-	-	-	1	BP
3-15	FDORRB182CBKZ	R-door assembly	-	-	1	-	BR
3-15-1	LSTP-A058CBM0	R-door stopper R	1	1	1	1	AF
3-15-2	LSTPPA084CBFA	Rd-stopper spring R	1	1	1	1	AD
3-15-3	PCOV-A252CBFA	Dc cover RR	1	-	-	-	AC
3-15-3	PCOV-A252CBFB	Dc cover RR	-	1	-	-	AC
3-15-3	PCOV-A252CBFC	Dc cover RR	-	-	-	1	AC
3-15-3	PCOV-A252CBFF	Dc cover RR	-	-	1	-	AC
3-17	FPACGA314CBKZ	R-door packing	1	1	1	1	AY
3-18	HDECQA385CBFA	Handle trim RL	1	1	1	-	AG
3-18	HDECQA385CBFB	Handle trim RL	-	-	-	1	AG
3-19	JHNDPA118CBFA	Door handle RL	1	-	-	-	AK
3-19	JHNDPA118CBFB	Door handle RL	-	1	-	-	AM
3-19	JHNDPA118CBFC	Door handle RL	-	-	-	1	AN
3-19	JHNDPA118CBFF	Door handle RL	-	-	1	-	AP
3-25	FBDGDA280CBYZ	Badge assembly	1	1	1	1	AY

OTHER PARTS

4-1	LBND-A023CBE0	L-band C	4	4	4	4	AC
4-3	LX-VZA003CBE0	Special screw	2	2	2	2	AB
4-10	QTAN-A013CBE0	Solderless term. A	4	4	4	4	AH
4-15	LX-BZA018CBE0	Special screw	1	1	1	1	AA
4-17	LX-WZA003CBE0	Washer	4	4	4	4	AA
4-18	LX-BZA076CBEZ	Handle screw	10	10	10	10	AC

REF. NO.	PART NO.	DESCRIPTION	Q'TY				CODE
			SJ-63L -A2G	SJ-63L -A2B	SJ-63L -A2L	SJ-63L -A2A	

ATTACHMENT PARTS

5-1	UPOK-A166CBRA	Bottle pocket	2	2	2	2	AN
5-3	UPOK-A168CBRA	F door pocket	2	2	2	2	AP
5-4	UPOK-A165CBRA	R door pocket	1	1	1	1	AN
5-5	UTNA-A282CBFB	Egg tray	2	2	2	2	AG
5-6	FSRA-A193CBYZ	Ice cube maker	1	1	1	1	AS
5-9	FSRA-A194CBKZ	F shelf assembly	1	1	1	1	AY
5-13	HGRL-A178CBFA	Ventilating grille	1	-	-	-	AG
5-13	HGRL-A178CBFB	Ventilating grille	-	1	-	-	AM
5-13	HGRL-A178CBFC	Ventilating grille	-	-	-	1	AN
5-13	HGRL-A178CBFF	Ventilating grille	-	-	1	-	AN
5-14	USRA-A252CBFA	Drain pan	1	1	1	1	AN
5-15	UYOK-A330CBFA	Fruit case	1	1	1	1	AW
5-16	UYOK-A331CBFA	Vegetable case	1	1	1	1	AZ
5-17	UYOK-A328CBFA	Ice storage box	1	1	1	1	AF
5-18	UYOK-A329CBFA	Chilled case	1	1	1	1	AX
5-19	GDORPA066CBRA	Chilled door	1	1	1	1	AP
5-24	FTNA-A301CBKZ	R glass shelf assembly	2	2	2	2	BC
5-25	FTNA-A302CBKZ	V glass shelf assembly	1	1	1	1	BC
5-26	PCAP-A076CBFA	Venti.grille cap	1	-	-	-	AC
5-26	PCAP-A076CBFB	Venti.grille cap	-	1	-	-	AC
5-26	PCAP-A076CBFC	Venti.grille cap	-	-	-	1	AD
5-26	PCAP-A076CBFF	Venti.grille cap	-	-	1	-	AC
5-28	PCAP-A069CBFA	V sliding cap L	1	1	1	1	AC
5-29	PCAP-A070CBFA	V sliding cap R	1	1	1	1	AC
5-31	LRALPA132CBFA	Ice tray holder L	1	1	1	1	AF
5-32	LRALPA133CBFA	Ice tray holder R	1	1	1	1	AF
5-33	LRALPA134CBFA	Ice tray holder B	1	1	1	1	AF
5-34	PCUP-A009CBFA	Water cup	1	1	1	1	AD
5-35	UPOKPA251CBFA	Tube stand	2	2	2	2	AC
5-36	PCOV-A259CBFA	Case cover	1	1	1	1	AH
5-37	UPOK-A167CBRA	Utility case pocket	1	1	1	1	AM

CYCLE PARTS

6-1	PCMPLA196CBE0	Compressor	1	1	1	1	BX
6-2	PSPAGA028CBE0	Rubber grommet	4	4	4	4	AD
6-3	FCONSA077CBKZ	Sub. condenser assembly	1	1	1	1	AX
6-3-1	PCOV-A256CBFA	Pipe protector L	1	1	1	1	AF
6-3-2	PCOV-A257CBFA	Pipe protector R	1	1	1	1	AF
6-4	FFRM-A113CBKZ	Base frame assembly	1	1	1	1	AW
6-5	FDYR-A006CBK0	Dryer assembly	1	1	1	1	AX
6-6	PCLI-A035CBE0	Clip	1	1	1	1	AC
6-9	PSPAFA020CBE0	Sleeve	4	4	4	4	AB
6-11	PPIPICA357CBEZ	S.p connector	1	1	1	1	AK
6-15	PGUM-A002CBF0	Absorbent rubber B	1	1	1	1	AH
6-18	PPIPICA252CBE0	Charge pipe	2	2	2	2	AD
6-21	PCOVPA165CBE0	Terminal cover	1	1	1	1	AF
6-27	PSEL-B899CBEZ	S-sealer	2	2	2	2	AC
6-28	PKYU-A143CBEZ	S-butyl	1	1	1	1	AD
6-29	PKYU-A036CBE0	Sp-butyl d-poy	1	1	1	1	AP
6-30	PKYU-A098CBE0	Compressor butyl	1	1	1	1	AG

MISCELLANEOUS

90-1	TINS-A491CBRZ	Operation manual	1	1	1	1	AF
90-2	TLAB-A092CBR0	Lamp label	1	1	1	1	AD
90-3	SPAKCI777YDEZ	Packing case 63L	1	1	1	1	BC
90-5	TLAB-A897CBEZ	Case label A2G	4	-	-	-	AC
90-5	TLAB-A916CBEZ	Case label A2B	-	4	-	-	AC
90-5	TLAB-A927CBEZ	Case label A2L	-	-	4	-	AC
90-5	TLAB-A937CBEZ	Case label A2A	-	-	-	4	AB
90-6	CPADBA765YDKZ	Bottom pad assembly	1	1	1	1	AY
90-7	CPADBA764YDKZ	Top pad assembly	1	1	1	1	AR
90-8	TLAB-A876CBRZ	Warning label	1	1	1	1	AC
90-21	TLAB-A939CBRZ	Caution label ROF	1	1	1	1	AD

HOW TO ORDER REPLACEMENT PARTS

To have your order filled promptly and correctly, please furnish the following information.

1. MODEL NUMBER
2. REF. NO.
3. PART NO.
4. DESCRIPTION

REPLACEMENT PARTS LIST(SJ-68L-A2G/A2B/A2L/A2A)

REF. NO.	PART NO.	DESCRIPTION	Q'TY				CODE
			SJ-68L -A2G	SJ-68L -A2B	SJ-68L -A2L	SJ-68L -A2A	

ELECTRIC PARTS

1-1	RTHM-A097CBEZ	F-thermostat	1	1	1	1	AX
1-2	RSTT-A144CBE0	Starting relay	1	1	1	1	AW
1-3	QSWTDA035CBE0	Defrost timer	1	1	1	1	BB
1-4	PDMP-A046CBEZ	Damper thermo	1	1	1	1	AX
1-5	FTHM-A028CBKZ	Defrost thermo.assembly	1	1	1	1	AN
1-6	RMOTRA040CBE0	Fan motor	1	1	1	1	AZ
1-7	QSOCAA074CBEZ	Lamp socket	1	1	1	1	AP
1-8	RLMP-A012CBE0	Lamp	1	1	1	1	AH
1-9	QACC-A096CBE0	Source cord	1	1	1	1	AX
1-10	QSW-PA090CBZA	Door switch	1	1	1	1	AS
1-11	RHOG-A105CBE0	Protector	1	1	1	1	AV
1-17	FFS-TA055CBKZ	Fuse assembly	1	1	1	1	AL
1-20	FW-VZA144CBEZ	Lead EV-cover assembly	1	1	1	1	AK
1-21	FHETBA149CBEZ	Def.heater assembly	1	1	1	1	BB
1-22	FCNW-A517CBK0	Relay cord S assembly	1	1	1	1	AM
1-25	QTAN-A032CBE0	Terminal block	1	1	1	1	AE
1-27	RMOTRA061CBEZ	Fan motor	1	1	1	1	AW
1-28	RLMP-A029CBEZ	Lamp15W	1	1	1	1	AH
1-29	QSOCAA072CBEZ	Lamp socket	1	1	1	1	AN
1-30	FTHM-A029CBKZ	R fan thermo assembly	1	1	1	1	AQ

MECHANICAL PARTS

2-2	JKNB-A036CBFB	F-temp. control knob	1	1	1	1	AD
2-4	LPLTMA568CBEZ	Fl plate AL.	1	1	1	1	AF
2-7	FLEGPA077CBKZ	Leg holder L assembly	1	1	1	1	AQ
2-7-1	FAJS-A009CBK0	Adjustable leg assembly	2	2	2	2	AD
2-7-2	LHLD-A533CBPZ	Leg holder L	1	1	1	1	AL
2-8	FLEGPA078CBKZ	Leg holder R assembly	1	1	1	1	AQ
2-8-2	LHLD-A534CBPZ	Leg holder R	1	1	1	1	AP
2-10	PSPAVA083CBEA	Upper hinge spacer	1	1	1	1	AD
2-11	PSPAVA084CBEA	Bottom hinge spacer	1	1	1	1	AC
2-12	PSPAVA075CBEA	Center hinge spacer	1	1	1	1	AD
2-13	DHNG-A363CBMZ	Upper hinge assembly	1	1	1	1	AE
2-14	DHNG-A365CBMZ	Bottom hinge R assembly	1	1	1	1	AE
2-15	DHNG-A364CBMZ	Center hinge R assembly	1	1	1	1	AF
2-16	GCOV-A191CBFZ	E.V cover	1	1	1	1	AS
2-17	LCRA-A010CBE0	Fan clamp	2	2	2	2	AD
2-19	LHLD-A389CBF0	Motor cushion	2	2	2	2	AF
2-20	NFANPA020CBFA	Propeller fan 100	1	1	1	1	AE
2-21	PSEL-B845CBEZ	E.V cover sealer A	1	1	1	1	AC
2-22	PSEL-B846CBEZ	E.V cover sealer B	1	1	1	1	AC
2-23	PSEL-A415CBE0	E.V cover sealer C	1	1	1	1	AC
2-24	PCOVPA164CBFA	Terminal cover	1	1	1	1	AE
2-25	PCOV-A253CBFA	F lamp cover	1	1	1	1	AC
2-26	PCOV-A254CBFA	R lamp cover	1	1	1	1	AF
2-27	GCOVPA119CBRA	R-cbox cover	1	1	1	1	AS
2-28	HGRL-A184CBRA	Fan louver	1	1	1	1	AU
2-29	GCOV-A162CBFB	Upper hinge cover	-	1	-	-	AD
2-29	GCOV-A162CBFG	Upper hinge cover	1	-	-	-	AD
2-29	GCOV-A162CBFH	Upper hinge cover	-	-	-	1	AD
2-29	GCOV-A162CBFK	Upper hinge cover	-	-	1	-	AD
2-30	PCOV-A255CBFA	Fan cover	2	2	2	2	AD
2-31	JKNB-A033CBFB	R-temp.control knob	1	1	1	1	AD
2-36	PCAP-A006CBFS	Screw cover	-	2	-	-	AB
2-36	PCAP-A006CBFU	Screw cover	-	-	2	-	AB
2-36	PCAP-A006CBFX	Screw cover	2	-	-	-	AB
2-36	PCAP-A006CBFY	Screw cover	-	-	-	2	AB
2-37	PCAP-A056CBFF	Screw cover B	2	2	2	2	AC
2-38	PGID-A156CBFZ	R air guider A	1	1	1	1	AG
2-41	PSEL-B848CBEZ	A-sealer thermo.cap	1	1	1	1	AC
2-49	LSTPPA108CBFA	Chilled stopper	2	2	2	2	AC
2-50	NFANPA019CBFA	Propeller fan 80	1	1	1	1	AM
2-51	PBOX-A121CBFA	F lamp box	1	1	1	1	AF
2-52	PBOX-A122CBFA	R lamp box	1	1	1	1	AM
2-53	LHLD-A536CBFA	R fan motor holder A	1	1	1	1	AF
2-54	LHLD-A537CBFA	R fan motor holder B	1	1	1	1	AE
2-55	HGRL-A181CBFA	Multi louver L	1	1	1	1	AN
2-56	PFPFPB233CBFZ	R-louver insu. L	1	1	1	1	AG
2-57	PSEL-B843CBEZ	A-sealer r-louver	2	2	2	2	AC
2-59	PCOV-A264CBEZ	F lamp box cover	1	1	1	1	AC
2-63	LHLD-A484CBFA	Fan motor holder B	1	1	1	1	AH
2-64	LHLD-A485CBFA	Fan motor holder A	1	1	1	1	AH
2-65	PSEL-B209CBE0	U-sealer handle	2	2	2	2	AB
2-66	PSHEMA132CBP0	Heater cover AL	1	1	1	1	AD

REF. NO.	PART NO.	DESCRIPTION	Q'TY				CODE
			SJ-68L -A2G	SJ-68L -A2B	SJ-68L -A2L	SJ-68L -A2A	
2-67	LPLTMA570CBPZ	Drain support AL	1	1	1	1	AE
2-69	PSEL-B847CBEZ	E.V cover sealer D	2	2	2	2	AC
2-71	PSEL-A552CBE0	Dial sealer	1	1	1	1	AC
2-72	PSEL-B841CBEZ	RA sealer A	2	2	2	2	AC
2-73	PSEL-B842CBEZ	RA sealer B	1	1	1	1	AC
2-74	PSEL-B122CBE0	A-sealer thermo.cap.	1	1	1	1	AB
2-77	LHLD-A391CBE0	Sl-5N clip	1	1	1	1	AD
2-78	LPLTMA399CBP0	Dryer support	1	1	1	1	AD
2-79	LBND-A019CBE0	Nylon band	1	1	1	1	AB
2-80	PBOX-A071CBFA	Terminal box	1	1	1	1	AE
2-81	PPIPPA097CBEZ	Drain pipe S	1	1	1	1	AE
2-83	PSEL-B849CBEZ	Ra sealer C	1	1	1	1	AC
2-84	PSEL-B850CBEZ	Ra sealer D	1	1	1	1	AC
2-86	LBND-A026CBE0	Nylon band	1	1	1	1	AD
2-87	LBND-A018CBE0	Fasting band A	1	1	1	1	AP
2-90	HGRL-A179CBFA	F shower duct	1	1	1	1	AM
2-91	HGRL-A180CBFA	F return cover	2	2	2	2	AC
2-93	PCAP-A068CBFA	C sliding cap A	2	2	2	2	AC
2-95	NROL-A027CBEZ	V roller	2	2	2	2	AC
2-96	LHLD-A535CBFA	Shaft holder	2	2	2	2	AC
2-97	LPIN-A178CB1Z	Shaft	2	2	2	2	AC
2-99	GCOV-A192CBFA	Top cover	1	-	-	-	AC
2-99	GCOV-A192CBFB	Top cover	-	1	-	-	AK
2-99	GCOV-A192CBFC	Top cover	-	-	-	1	AD
2-99	GCOV-A192CBFF	Top cover	-	-	1	-	AC
2-105	PSEL-B896CBEZ	A-sealer FS-A	1	1	1	1	AC
2-106	PSEL-B897CBEZ	A-sealer FS-B	2	2	2	2	AC

DOOR PARTS

3-5	FDORFB299CBKZ	F-door assembly	1	-	-	-	BK
3-5	FDORFB306CBKZ	F-door assembly	-	1	-	-	BM
3-5	FDORFB307CBKZ	F-door assembly	-	-	-	1	BK
3-5	FDORFB313CBKZ	F-door assembly	-	-	1	-	BL
3-5-1	LSTPPA107CBFA	Fd stopper spring R	1	1	1	1	AD
3-5-2	NBRGPA022CBFA	Nylon bearing 3S	2	2	2	2	AC
3-5-3	PCOV-A251CBFA	Dc cover FR	1	-	-	-	AC
3-5-3	PCOV-A251CBFB	Dc cover FR	-	1	-	-	AC
3-5-3	PCOV-A251CBFC	Dc cover FR	-	-	-	1	AC
3-5-3	PCOV-A251CBFF	Dc cover FR	-	-	1	-	AC
3-6	FPACGA309CBKZ	F-door packing	1	1	1	1	AX
3-7	HDECQA384CBFA	Handle trim FL	1	1	1	-	AD
3-7	HDECQA384CBFB	Handle trim FL	-	-	-	1	AG
3-8	JHNDPA117CBFA	Door handle FL	1	-	-	-	AK
3-8	JHNDPA117CBFB	Door handle FL	-	1	-	-	AM
3-8	JHNDPA117CBFC	Door handle FL	-	-	-	1	AN
3-8	JHNDPA117CBFF	Door handle FL	-	-	1	-	AP
3-9	PCAP-A067CBFA	Screw cover HD	10	-	-	-	AC
3-9	PCAP-A067CBFB	Screw cover HD	-	10	-	-	AC
3-9	PCAP-A067CBFC	Screw cover HD	-	-	-	10	AD
3-9	PCAP-A067CBFF	Screw cover HD	-	-	10	-	AC
3-15	FDORRB166CBKZ	R-door assembly	1	-	-	-	BQ
3-15	FDORRB168CBKZ	R-door assembly	-	1	-	-	BR
3-15	FDORRB169CBKZ	R-door assembly	-	-	-	1	BP
3-15	FDORRB175CBKZ	R-door assembly	-	-	1	-	BQ
3-15-1	LSTP-A058CBM0	R-door stopper R	1	1	1	1	AF
3-15-2	LSTPPA084CBFA	Rd-stopper spring R	1	1	1	1	AD
3-15-3	PCOV-A252CBFA	Dc cover RR	1	-	-	-	AC
3-15-3	PCOV-A252CBFB	Dc cover RR	-	1	-	-	AC
3-15-3	PCOV-A252CBFC	Dc cover RR	-	-	-	1	AC
3-15-3	PCOV-A252CBFF	Dc cover RR	-	-	1	-	AC
3-17	FPACGA310CBKZ	R-door packing	1	1	1	1	AY
3-18	HDECQA385CBFA	Handle trim RL	1	1	1	-	AG
3-18	HDECQA385CBFB	Handle trim RL	-	-	-	1	AG
3-19	JHNDPA118CBFA	Door handle RL	1	-	-	-	AK
3-19	JHNDPA118CBFB	Door handle RL	-	1	-	-	AM
3-19	JHNDPA118CBFC	Door handle RL	-	-	-	1	AN
3-19	JHNDPA118CBFF	Door handle RL	-	-	1	-	AP
3-25	FBDGDA280CBYZ	Badge assembly	1	1	1	1	AN

OTHER PARTS

4-1	LBND-A023CBE0	L-band C	4	4	4	4	AC
4-3	LX-VZA003CBE0	Special screw	2	2	2	2	AB
4-10	QTAN-A013CBE0	Solderless term. A	4	4	4	4	AH
4-15	LX-BZA018CBE0	Special screw	1	1	1	1	AA
4-17	LX-WZA003CBE0	Washer	4	4	4	4	AA
4-18	LX-BZA076CBEZ	Handle screw	10	10	10	10	AC

REF. NO.	PART NO.	DESCRIPTION	Q'TY				CODE
			SJ-68L -A2G	SJ-68L -A2B	SJ-68L -A2L	SJ-68L -A2A	

ATTACHMENT PARTS

5-1	UPOK-A166CBRA	Bottle pocket	2	2	2	2	AN
5-3	UPOK-A168CBRA	F door pocket	2	2	2	2	AP
5-4	UPOK-A165CBRA	R door pocket	2	2	2	2	AN
5-5	UTNA-A282CBFB	Egg tray	2	2	2	2	AG
5-6	FSRA-A193CBYZ	Ice cube maker	1	1	1	1	AS
5-9	FSRA-A194CBKZ	F shelf assembly	1	1	1	1	AY
5-13	HGRL-A178CBFA	Ventilating grille	1	-	-	-	AG
5-13	HGRL-A178CBFB	Ventilating grille	-	1	-	-	AM
5-13	HGRL-A178CBFC	Ventilating grille	-	-	-	1	AN
5-13	HGRL-A178CBFF	Ventilating grille	-	-	1	-	AN
5-14	USRA-A252CBFA	Drain pan	1	1	1	1	AN
5-15	UYOK-A330CBFA	Fruit case	1	1	1	1	AW
5-16	UYOK-A331CBFA	Vegetable case	1	1	1	1	AZ
5-17	UYOK-A328CBFA	Ice storage box	1	1	1	1	AF
5-18	UYOK-A329CBFA	Chilled case	1	1	1	1	AX
5-19	GDORPA066CBRA	Chilled door	1	1	1	1	AP
5-24	FTNA-A301CBKZ	R glass shelf assembly	3	3	3	3	BC
5-25	FTNA-A302CBKZ	V glass shelf assembly	1	1	1	1	BC
5-26	PCAP-A076CBFA	Venti.grille cap	1	-	-	-	AC
5-26	PCAP-A076CBFB	Venti.grille cap	-	1	-	-	AC
5-26	PCAP-A076CBFC	Venti.grille cap	-	-	-	1	AD
5-26	PCAP-A076CBFF	Venti.grille cap	-	-	1	-	AC
5-28	PCAP-A069CBFA	V sliding cap L	1	1	1	1	AC
5-29	PCAP-A070CBFA	V sliding cap R	1	1	1	1	AC
5-31	LRALPA132CBFA	Ice tray holder L	1	1	1	1	AF
5-32	LRALPA133CBFA	Ice tray holder R	1	1	1	1	AF
5-33	LRALPA134CBFA	Ice tray holder B	1	1	1	1	AF
5-34	PCUP-A009CBFA	Water cup	1	1	1	1	AD
5-35	UPOKPA251CBFA	Tube stand	2	2	2	2	AC
5-36	PCOV-A259CBFA	Case cover	1	1	1	1	AH
5-37	UPOK-A167CBRA	Utility case pocket	1	1	1	1	AM

CYCLE PARTS

6-1	PCMPLA202CBEZ	Compressor	1	1	1	1	BX
6-2	PSPAGA028CBE0	Rubber grommet	4	4	4	4	AD
6-3	FCONSA077CBKZ	Sub. condenser assembly	1	1	1	1	AX
6-3-1	PCOV-A256CBFA	Pipe protector L	1	1	1	1	AF
6-3-2	PCOV-A257CBFA	Pipe protector R	1	1	1	1	AF
6-4	FFRM-A113CBKZ	Base frame assembly	1	1	1	1	AW
6-5	FDRY-A006CBK0	Dryer assembly	1	1	1	1	AX
6-6	PCLI-A035CBE0	Clip	1	1	1	1	AC
6-9	PSPAFA020CBE0	Sleeve	4	4	4	4	AB
6-11	PPIPCA357CBEZ	S.P connector	1	1	1	1	AK
6-15	PGUM-A002CBF0	Absorbent rubber B	1	1	1	1	AH
6-18	PPIPCA252CBE0	Charge pipe	2	2	2	2	AD
6-21	PCOVPA165CBE0	Terminal cover	1	1	1	1	AF
6-27	PSEL-B899CBEZ	S-sealer	2	2	2	2	AC
6-28	PKYU-A143CBEZ	S-butyl	1	1	1	1	AD
6-29	PKYU-A036CBE0	Sp-butyl d-poy	1	1	1	1	AP
6-30	PKYU-A098CBE0	Compressor butyl	1	1	1	1	AG

MISCELLANEOUS

90-1	TINS-A491CBRZ	Operation manual	1	1	1	1	AF
90-2	TLAB-A092CBR0	Lamp label	1	1	1	1	AD
90-3	SPAKCI775YDEZ	Packing case 68L	1	1	1	1	BC
90-5	TLAB-A897CBEZ	Case label A2G	4	-	-	-	AC
90-5	TLAB-A916CBEZ	Case label A2B	-	4	-	-	AC
90-5	TLAB-A927CBEZ	Case label A2L	-	-	4	-	AC
90-5	TLAB-A937CBEZ	Case label A2A	-	-	-	4	AB
90-6	CPADBA765YDKZ	Bottom pad assembly	1	1	1	1	AY
90-7	CPADBA764YDKZ	Top pad assembly	1	1	1	1	AR
90-8	TLAB-A876CBRZ	Warning label	1	1	1	1	AC
90-21	TLAB-A939CBRZ	Caution label ROF	1	1	1	1	AD

HOW TO ORDER REPLACEMENT PARTS

To have your order filled promptly and correctly, please furnish the following information.

1. MODEL NUMBER
2. REF. NO.
3. PART NO.
4. DESCRIPTION

DOOR PARTS

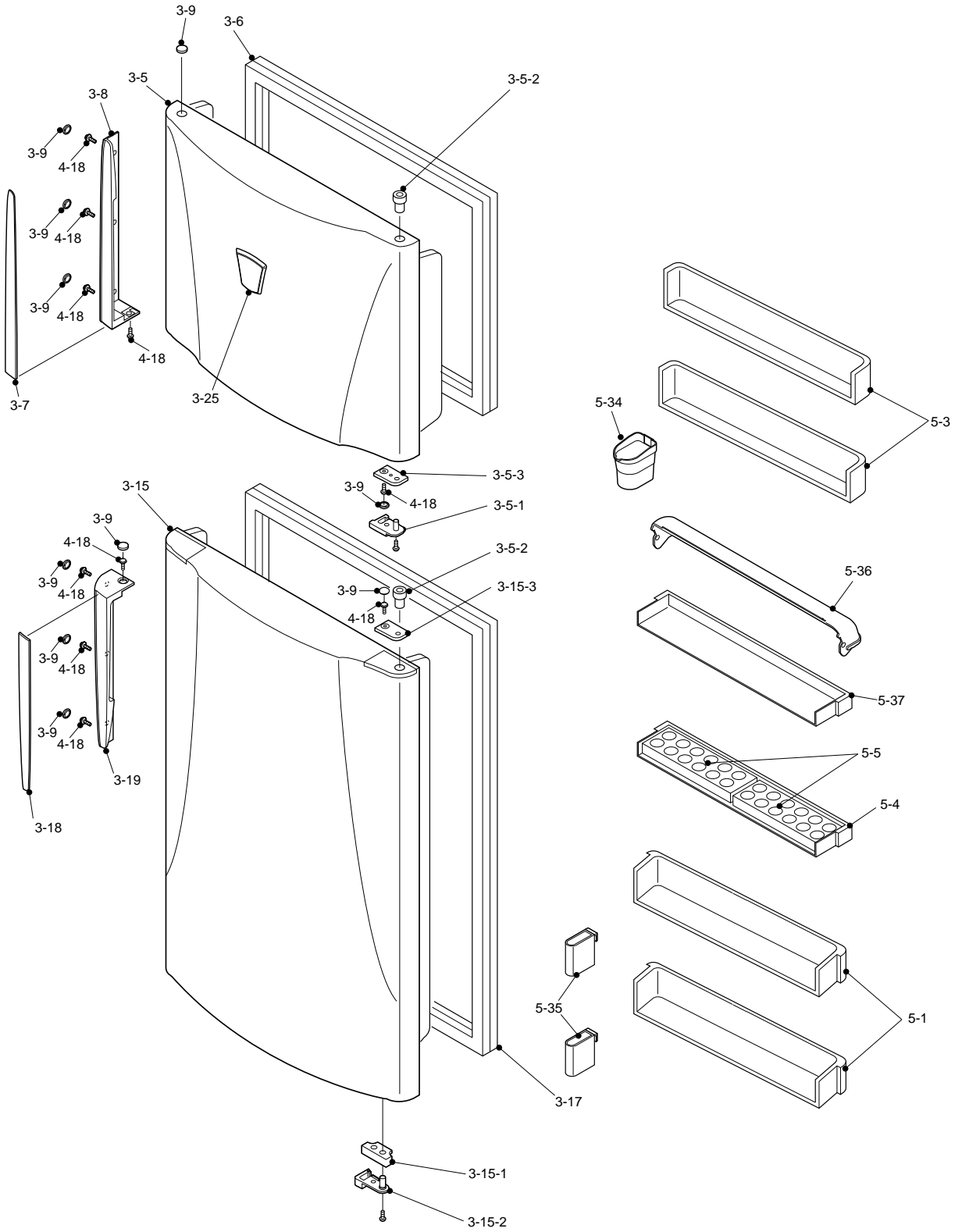

SJ-58L-A2
SJ-63L-A2
SJ-68L-A2

CABINET PARTS

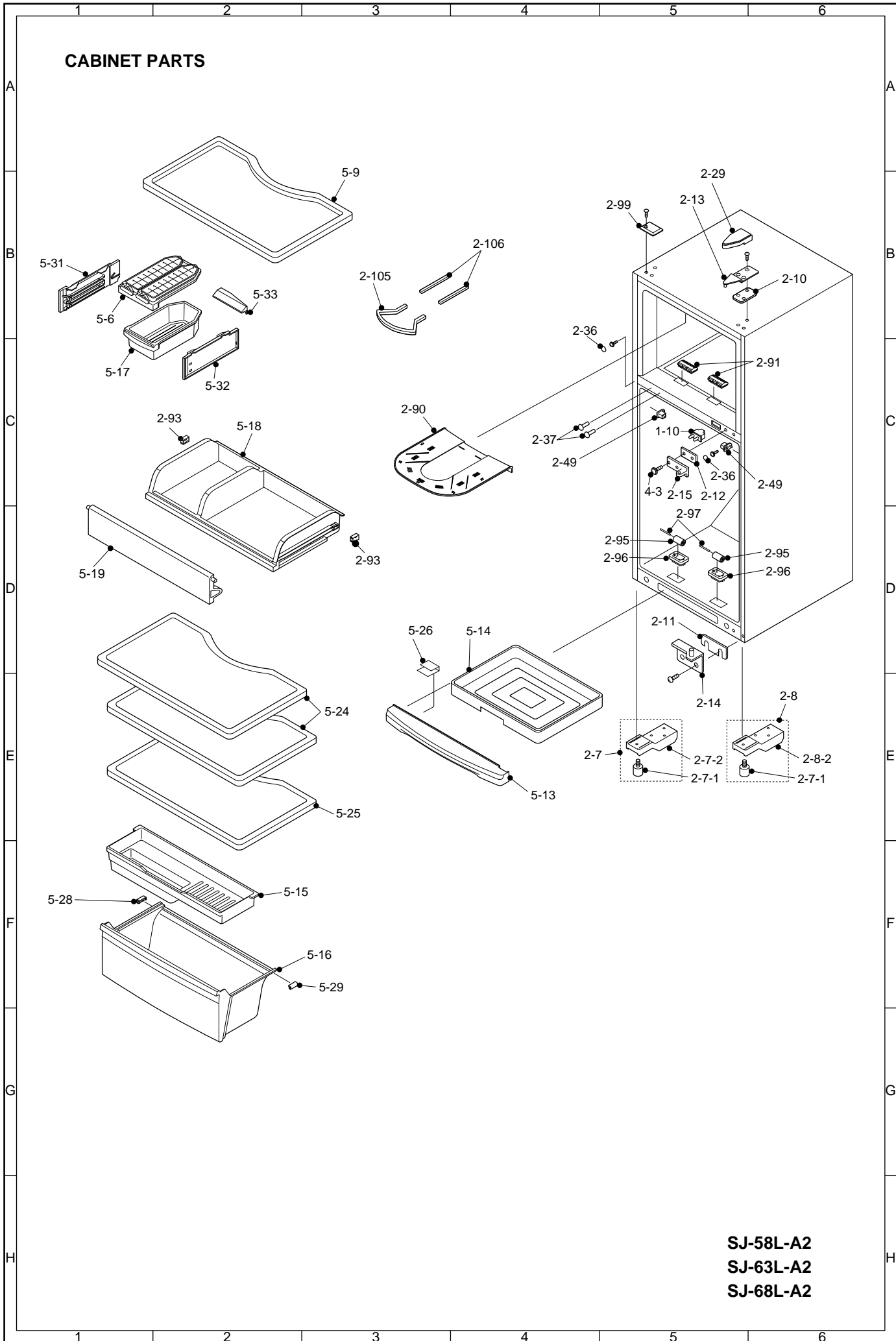

SJ-58L-A2
SJ-63L-A2
SJ-68L-A2

SHARP SERVICE MANUAL

REPLACEMENT PARTS LIST

MODELS

SJ-58L-A2G/A2B/A2L/A2A

SJ-63L-A2G/A2B/A2L/A2A

SJ-68L-A2G/A2B/A2L/A2A

DESTINATION Y

REPLACEMENT PARTS LIST(SJ-58L-A2G/A2B/A2L/A2A)

REF. NO.	PART NO.	DESCRIPTION	Q'TY				CODE
			SJ-58L -A2G	SJ-58L -A2B	SJ-58L -A2L	SJ-58L -A2A	

ELECTRIC PARTS

1-1	RTHM-A097CBEZ	F-thermostat	1	1	1	1	AX
1-2	RSTT-A144CBE0	Starting relay	1	1	1	1	AW
1-3	QSWTDA035CBE0	Defrost timer	1	1	1	1	BB
1-4	PDMP-A046CBEZ	Damper thermo	1	1	1	1	AX
1-5	FTHM-A028CBKZ	Defrost thermo. assembly	1	1	1	1	AN
1-6	RMOTRA040CBE0	Fan motor	1	1	1	1	AZ
1-7	QSOCAA074CBEZ	Lamp socket	1	1	1	1	AP
1-8	RLMP-A012CBE0	Lamp	1	1	1	1	AH
1-9	QACC-A101CBE0	Source cord	1	1	1	1	AN
1-10	QSW-PA090CBZA	Door switch	1	1	1	1	AS
1-11	RHOG-A084CBE0	Protector	1	1	1	1	AN
1-17	FFS-TA055CBKZ	Fuse assembly	1	1	1	1	AL
1-20	FW-VZA144CBEZ	Lead ev-cover assembly	1	1	1	1	AK
1-21	FHETBA149CBEZ	Def.heater assembly	1	1	1	1	BB
1-22	FCNW-A514CBK0	Relay cord S assembly	1	1	1	1	AN
1-25	QTAN-A032CBE0	Terminal block	1	1	1	1	AE
1-27	RMOTRA061CBEZ	Fan motor	1	1	1	1	AW
1-28	RLMP-A029CBEZ	Lamp15W	1	1	1	1	AH
1-29	QSOCAA072CBEZ	Lamp socket	1	1	1	1	AN
1-30	FTHM-A029CBKZ	R fan thermo assembly	1	1	1	1	AQ

MECHANICAL PARTS

2-2	JKNB-A036CBFB	F-temp. control knob	1	1	1	1	AD
2-4	LPLTMA568CBEZ	F1 plate AL.	1	1	1	1	AF
2-7	FLEGPA077CBKZ	Leg holder L assembly	1	1	1	1	AQ
2-7-1	FAJS-A009CBK0	Adjustable leg assembly	2	2	2	2	AD
2-7-2	LHLD-A533CBPZ	Leg holder L	1	1	1	1	AL
2-8	FLEGPA078CBKZ	Leg holder R assembly	1	1	1	1	AQ
2-8-2	LHLD-A534CBPZ	Leg holder R	1	1	1	1	AP
2-10	PSPAVA083CBEA	Upper hinge spacer	1	1	1	1	AD
2-11	PSPAVA084CBEA	Bottom hinge spacer	1	1	1	1	AC
2-12	PSPAVA075CBEA	Center hinge spacer	1	1	1	1	AD
2-13	DHNG-A363CBMZ	Upper hinge assembly	1	1	1	1	AE
2-14	DHNG-A365CBMZ	Bottom hinge R assembly	1	1	1	1	AE
2-15	DHNG-A364CBMZ	Center hinge R assembly	1	1	1	1	AF
2-16	GCOV-A191CBFZ	E.V cover	1	1	1	1	AS
2-17	LCRA-A010CBE0	Fan clamp	2	2	2	2	AD
2-19	LHLD-A389CBF0	Motor cushion	2	2	2	2	AF
2-20	NFANPA020CBFA	Propeller fan 100	1	1	1	1	AE
2-21	PSEL-B845CBEZ	E.V cover sealer A	1	1	1	1	AC
2-22	PSEL-B846CBEZ	E.V cover sealer B	1	1	1	1	AC
2-23	PSEL-A415CBE0	E.V cover sealer C	1	1	1	1	AC
2-24	PCOVPA175CBFA	Terminal cover	1	1	1	1	AF
2-25	PCOV-A253CBFA	F lamp cover	1	1	1	1	AC
2-26	PCOV-A254CBFA	R lamp cover	1	1	1	1	AF
2-27	GCOVPA119CBRA	R-cbox cover	1	1	1	1	AS
2-28	HGRL-A184CBRA	Fan louver	1	1	1	1	AU
2-29	GCOV-A162CBFB	Upper hinge cover	-	1	-	-	AD
2-29	GCOV-A162CBFG	Upper hinge cover	1	-	-	-	AD
2-29	GCOV-A162CBFH	Upper hinge cover	-	-	-	1	AD
2-29	GCOV-A162CBFK	Upper hinge cover	-	-	1	-	AD
2-30	PCOV-A255CBFA	Fan cover	2	2	2	2	AD
2-31	JKNB-A033CBFB	R-temp.control knob	1	1	1	1	AD
2-36	PCAP-A006CBFS	Screw cover	-	2	-	-	AB
2-36	PCAP-A006CBFU	Screw cover	-	-	2	-	AB
2-36	PCAP-A006CBFX	Screw cover	2	-	-	-	AB
2-36	PCAP-A006CBFY	Screw cover	-	-	-	2	AB
2-37	PCAP-A056CBFF	Screw cover B	2	2	2	2	AC
2-38	PGID-A156CBFZ	R air guider A	1	1	1	1	AG
2-41	PSEL-B848CBEZ	A-sealer thermo.cap	1	1	1	1	AC
2-49	LSTPPA108CBFA	Chilled stopper	2	2	2	2	AC
2-50	NFANPA019CBFA	Propeller fan 80	1	1	1	1	AM
2-51	PBOX-A121CBFA	F lamp box	1	1	1	1	AF
2-52	PBOX-A122CBFA	R lamp box	1	1	1	1	AM
2-53	LHLD-A536CBFA	R fan motor holder A	1	1	1	1	AF
2-54	LHLD-A537CBFA	R fan motor holder B	1	1	1	1	AE
2-55	HGRL-A188CBFA	Multi louver S	1	1	1	1	AG
2-56	PFPFPB248CBFZ	R-louver insu. S	1	1	1	1	AE
2-57	PSEL-B861CBEZ	A-sealer R-louver	2	2	2	2	AC
2-59	PCOV-A264CBEZ	F lamp box cover	1	1	1	1	AC
2-63	LHLD-A484CBFA	Fan motor holder B	1	1	1	1	AH
2-64	LHLD-A485CBFA	Fan motor holder A	1	1	1	1	AH
2-65	PSEL-B209CBE0	U-sealer handle	2	2	2	2	AB
2-66	PSHEMA132CBP0	Heater cover AL	1	1	1	1	AD

REF. NO.	PART NO.	DESCRIPTION	Q'TY				CODE
			SJ-58L -A2G	SJ-58L -A2B	SJ-58L -A2L	SJ-58L -A2A	
2-67	LPLTMA570CBPZ	Drain support AL	1	1	1	1	AE
2-69	PSEL-B847CBEZ	E.V cover sealer D	2	2	2	2	AC
2-71	PSEL-A552CBE0	Dial sealer	1	1	1	1	AC
2-72	PSEL-B841CBEZ	Ra sealer A	2	2	2	2	AC
2-73	PSEL-B842CBEZ	Ra sealer B	1	1	1	1	AC
2-74	PSEL-B122CBE0	A-sealer thermo.cap.	1	1	1	1	AB
2-77	LHLD-A359CBFA	T-box holder	1	1	1	1	AE
2-78	LPLTMA399CBP0	Dryer support	1	1	1	1	AD
2-79	LBND-A019CBE0	Nylon band	1	1	1	1	AB
2-80	PBOX-A078CBFA	Terminal box	1	1	1	1	AG
2-81	PPIPPA097CBEZ	Drain pipe S	1	1	1	1	AE
2-83	PSEL-B849CBEZ	Ra sealer C	1	1	1	1	AC
2-84	PSEL-B850CBEZ	Ra sealer D	1	1	1	1	AC
2-86	LBND-A026CBE0	Nylon band	1	1	1	1	AD
2-87	LBND-A018CBE0	Fasting band A	1	1	1	1	AP
2-90	HGRL-A179CBFA	F shower duct	1	1	1	1	AM
2-91	HGRL-A180CBFA	F return cover	2	2	2	2	AC
2-93	PCAP-A068CBFA	C sliding cap A	2	2	2	2	AC
2-95	NROL-A027CBEZ	V roller	2	2	2	2	AC
2-96	LHLD-A535CBFA	Shaft holder	2	2	2	2	AC
2-97	LPIN-A178CB1Z	Shaft	2	2	2	2	AC
2-98	LHLD-A504CBE0	SL-3N Clip	1	1	1	1	AD
2-99	GCOV-A192CBFA	Top cover	1	-	-	-	AC
2-99	GCOV-A192CBFB	Top cover	-	1	-	-	AK
2-99	GCOV-A192CBFC	Top cover	-	-	-	1	AD
2-99	GCOV-A192CBFF	Top cover	-	-	1	-	AC
2-105	PSEL-B896CBEZ	A-sealer FS-A	1	1	1	1	AC
2-106	PSEL-B897CBEZ	A-sealer FS-B	2	2	2	2	AC

DOOR PARTS

3-5	FDORFB299CBKZ	F-door assembly	1	-	-	-	BK
3-5	FDORFB306CBKZ	F-door assembly	-	1	-	-	BM
3-5	FDORFB307CBKZ	F-door assembly	-	-	-	1	BK
3-5	FDORFB313CBKZ	F-door assembly	-	-	1	-	BL
3-5-1	LSTPPA107CBFA	Fd stopper spring R	1	1	1	1	AD
3-5-2	NBRGPA022CBFA	Nylon bearing 3S	2	2	2	2	AC
3-5-3	PCOV-A251CBFA	Dc cover FR	1	-	-	-	AC
3-5-3	PCOV-A251CBFB	Dc cover FR	-	1	-	-	AC
3-5-3	PCOV-A251CBFC	Dc cover FR	-	-	-	1	AC
3-5-3	PCOV-A251CBFF	Dc cover FR	-	-	1	-	AC
3-6	FPACGA309CBKZ	F-door packing	1	1	1	1	AX
3-7	HDECQA384CBFA	Handle trim FL	1	1	1	-	AD
3-7	HDECQA384CBFB	Handle trim FL	-	-	-	1	AG
3-8	JHNDPA117CBFA	Door handle FL	1	-	-	-	AK
3-8	JHNDPA117CBFB	Door handle FL	-	1	-	-	AM
3-8	JHNDPA117CBFC	Door handle FL	-	-	-	1	AN
3-8	JHNDPA117CBFF	Door handle FL	-	-	1	-	AP
3-9	PCAP-A067CBFA	Screw cover HD	10	-	-	-	AC
3-9	PCAP-A067CBFB	Screw cover HD	-	10	-	-	AC
3-9	PCAP-A067CBFC	Screw cover HD	-	-	-	10	AD
3-9	PCAP-A067CBFF	Screw cover HD	-	-	10	-	AC
3-15	FDORRB181CBKZ	R-door assembly	1	-	-	-	BP
3-15	FDORRB183CBKZ	R-door assembly	-	1	-	-	BP
3-15	FDORRB184CBKZ	R-door assembly	-	-	-	1	BN
3-15	FDORRB189CBKZ	R-door assembly	-	-	1	-	BN
3-15-1	LSTP-A058CBM0	R-door stopper R	1	1	1	1	AF
3-15-2	LSTPPA084CBFA	Rd-stopper spring R	1	1	1	1	AD
3-15-3	PCOV-A252CBFA	Dc cover RR	1	-	-	-	AC
3-15-3	PCOV-A252CBFB	Dc cover RR	-	1	-	-	AC
3-15-3	PCOV-A252CBFC	Dc cover RR	-	-	-	1	AC
3-15-3	PCOV-A252CBFF	Dc cover RR	-	-	1	-	AC
3-17	FPACGA315CBKZ	R-door packing	1	1	1	1	AY
3-18	HDECQA385CBFA	Handle trim RL	1	1	1	-	AG
3-18	HDECQA385CBFB	Handle trim RL	-	-	-	1	AG
3-19	JHNDPA118CBFA	Door handle RL	1	-	-	-	AK
3-19	JHNDPA118CBFB	Door handle RL	-	1	-	-	AM
3-19	JHNDPA118CBFC	Door handle RL	-	-	-	1	AN
3-19	JHNDPA118CBFF	Door handle RL	-	-	1	-	AP
3-25	FBDGDA280CXYZ	Badge assembly	1	1	1	1	AY

OTHER PARTS

4-1	LBND-A023CBE0	L-band C	4	4	4	4	AC
4-3	LX-VZA003CBE0	Special screw	2	2	2	2	AB
4-10	QTAN-A013CBE0	Solderless term. A	4	4	4	4	AH
4-15	LX-BZ0202JBE0	Special screw	1	1	1	1	AA
4-17	LX-WZA003CBE0	Washer	4	4	4	4	AA
4-18	LX-BZA076CBEZ	Handle screw	10	10	10	10	AC

REF. NO.	PART NO.	DESCRIPTION	Q'TY				CODE
			SJ-58L -A2G	SJ-58L -A2B	SJ-58L -A2L	SJ-58L -A2A	

ATTACHMENT PARTS

5-1	UPOK-A166CBRA	Bottle pocket	2	2	2	2	AN
5-3	UPOK-A168CBRA	F door pocket	2	2	2	2	AP
5-4	UPOK-A165CBRA	R door pocket	1	1	1	1	AN
5-5	UTNA-A282CBFB	Egg tray	2	2	2	2	AG
5-6	FSRA-A193CBYZ	Ice cube maker	1	1	1	1	AS
5-9	FSRA-A194CBKZ	F shelf assembly	1	1	1	1	AY
5-13	HGRL-A178CBFA	Ventilating grille	1	-	-	-	AG
5-13	HGRL-A178CBFB	Ventilating grille	-	1	-	-	AM
5-13	HGRL-A178CBFC	Ventilating grille	-	-	-	1	AN
5-13	HGRL-A178CBFF	Ventilating grille	-	-	1	-	AN
5-14	USRA-A252CBFA	Drain pan	1	1	1	1	AN
5-15	UYOK-A330CBFA	Fruit case	1	1	1	1	AW
5-16	UYOK-A331CBFA	Vegetable case	1	1	1	1	AZ
5-17	UYOK-A328CBFA	Ice storage box	1	1	1	1	AF
5-18	UYOK-A329CBFA	Chilled case	1	1	1	1	AX
5-19	GDORPA066CBRA	Chilled door	1	1	1	1	AP
5-24	FTNA-A301CBKZ	R glass shelf assembly	2	2	2	2	BC
5-25	FTNA-A302CBKZ	V glass shelf assembly	1	1	1	1	BC
5-26	PCAP-A076CBFA	Venti.grille cap	1	-	-	-	AC
5-26	PCAP-A076CBFB	Venti.grille cap	-	1	-	-	AC
5-26	PCAP-A076CBFC	Venti.grille cap	-	-	-	1	AD
5-26	PCAP-A076CBFF	Venti.grille cap	-	-	1	-	AC
5-28	PCAP-A069CBFA	V sliding cap L	1	1	1	1	AC
5-29	PCAP-A070CBFA	V sliding cap R	1	1	1	1	AC
5-31	LRALPA132CBFA	Ice tray holder L	1	1	1	1	AF
5-32	LRALPA133CBFA	Ice tray holder R	1	1	1	1	AF
5-33	LRALPA134CBFA	Ice tray holder B	1	1	1	1	AF
5-34	PCUP-A009CBFA	Water cup	1	1	1	1	AD
5-35	UPOKPA251CBFA	Tube stand	2	2	2	2	AC
5-36	PCOV-A259CBFA	Case cover	1	1	1	1	AH
5-37	UPOK-A167CBRA	Utility case pocket	1	1	1	1	AM

CYCLE PARTS

6-1	PCMPLA196CBE0	Compressor	1	1	1	1	BX
6-2	PSPAGA028CBE0	Rubber grommet	4	4	4	4	AD
6-3	FCONSA077CBKZ	Sub. condenser assembly	1	1	1	1	AX
6-3-1	PCOV-A256CBFA	Pipe protector L	1	1	1	1	AF
6-3-2	PCOV-A257CBFA	Pipe protector R	1	1	1	1	AF
6-4	FFRM-A112CBKZ	Base frame assembly	1	1	1	1	AG
6-5	FDRY-A006CBK0	Dryer assembly	1	1	1	1	AX
6-6	PCLI-A035CBE0	Clip	1	1	1	1	AC
6-9	PSPAFA020CBE0	Sleeve	4	4	4	4	AB
6-11	PPIPCA357CBEZ	S.p connector	1	1	1	1	AK
6-15	PGUM-A002CBF0	Absorbent rubber B	1	1	1	1	AH
6-18	PPIPCA252CBE0	Charge pipe	2	2	2	2	AD
6-21	PCOVPA165CBE0	Terminal cover	1	1	1	1	AF
6-27	PSEL-B899CBEZ	S-sealer	2	2	2	2	AC
6-28	PKYU-A143CBEZ	S-butyl	1	1	1	1	AD
6-29	PKYU-A036CBE0	SP-butyl D-poy	1	1	1	1	AP
6-30	PKYU-A098CBE0	Compressor butyl	1	1	1	1	AG

MISCELLANEOUS

90-1	TINS-A490CBRZ	Operation manual	1	1	1	1	AG
90-2	TLAB-A092CBR0	Lamp label	1	1	1	1	AD
90-3	SPAKCI800YDEZ	Packing case 58L	1	1	1	1	BB
90-5	TLAB-A897CBEZ	Case label A2G	4	-	-	-	AC
90-5	TLAB-A916CBEZ	Case label A2B	-	4	-	-	AC
90-5	TLAB-A927CBEZ	Case label A2L	-	-	4	-	AC
90-5	TLAB-A937CBEZ	Case label A2A	-	-	-	4	AB
90-6	CPADBA765YDKZ	Bottom pad assembly	1	1	1	1	AY
90-7	CPADBA764YDKZ	Top pad assembly	1	1	1	1	AR
90-8	TLAB-A876CBRZ	Warning label	1	1	1	1	AC

HOW TO ORDER REPLACEMENT PARTS

To have your order filled promptly and correctly, please furnish the following information.

1. MODEL NUMBER
2. REF. NO.
3. PART NO.
4. DESCRIPTION

REPLACEMENT PARTS LIST(SJ-63L-A2G/A2B/A2L/A2A)

REF. NO.	PART NO.	DESCRIPTION	Q'TY				CODE
			SJ-63L -A2G	SJ-63L -A2B	SJ-63L -A2L	SJ-63L -A2A	

ELECTRIC PARTS

1-1	RTHM-A097CBEZ	F-thermostat	1	1	1	1	AX
1-2	RSTT-A144CBE0	Starting relay	1	1	1	1	AW
1-3	QSWTDA035CBE0	Defrost timer	1	1	1	1	BB
1-4	PDMP-A046CBEZ	Damper thermo	1	1	1	1	AX
1-5	FTHM-A028CBKZ	Defrost thermo.assembly	1	1	1	1	AN
1-6	RMOTRA040CBE0	Fan motor	1	1	1	1	AZ
1-7	QSOCAA074CBEZ	Lamp socket	1	1	1	1	AP
1-8	RLMP-A012CBE0	Lamp	1	1	1	1	AH
1-9	QACC-A101CBE0	Source cord	1	1	1	1	AN
1-10	QSW-PA090CBZA	Door switch	1	1	1	1	AS
1-11	RHOG-A084CBE0	Protector	1	1	1	1	AN
1-17	FFS-TA055CBKZ	Fuse assembly	1	1	1	1	AL
1-20	FW-VZA144CBEZ	Lead EV-cover assembly	1	1	1	1	AK
1-21	FHETBA149CBEZ	Def.heater assembly	1	1	1	1	BB
1-22	FCNW-A514CBK0	Relay cord s assembly	1	1	1	1	AN
1-25	QTAN-A032CBE0	Terminal block	1	1	1	1	AE
1-27	RMOTRA061CBEZ	Fan motor	1	1	1	1	AW
1-28	RLMP-A029CBEZ	Lamp 15W	1	1	1	1	AH
1-29	QSOCAA072CBEZ	Lamp socket	1	1	1	1	AN
1-30	FTHM-A029CBKZ	R fan thermo assembly	1	1	1	1	AQ

MECHANICAL PARTS

2-2	JKNB-A036CBFB	F-temp. control knob	1	1	1	1	AD
2-4	LPLTMA568CBEZ	Fl plate AL.	1	1	1	1	AF
2-7	FLEGPA077CBKZ	Leg holder L assembly	1	1	1	1	AQ
2-7-1	FAJS-A009CBK0	Adjustable leg assembly	2	2	2	2	AD
2-7-2	LHLD-A533CBPZ	Leg holder L	1	1	1	1	AC
2-8	FLEGPA078CBKZ	Leg holder R assembly	1	1	1	1	AQ
2-8-2	LHLD-A534CBPZ	Leg holder R	1	1	1	1	AP
2-10	PSPAVA083CBEA	Upper hinge spacer	1	1	1	1	AD
2-11	PSPAVA084CBEA	Bottom hinge spacer	1	1	1	1	AC
2-12	PSPAVA075CBEA	Center hinge spacer	1	1	1	1	AD
2-13	DHNG-A363CBMZ	Upper hinge assembly	1	1	1	1	AE
2-14	DHNG-A365CBMZ	Bottom hinge R assembly	1	1	1	1	AE
2-15	DHNG-A364CBMZ	Center hinge R assembly	1	1	1	1	AF
2-16	GCOV-A191CBFZ	E.V cover	1	1	1	1	AS
2-17	LCRA-A010CBE0	Fan clamp	2	2	2	2	AD
2-19	LHLD-A389CBF0	Motor cushion	2	2	2	2	AF
2-20	NFANPA020CBFA	Propeller fan 100	1	1	1	1	AE
2-21	PSEL-B845CBEZ	E.V cover sealer A	1	1	1	1	AC
2-22	PSEL-B846CBEZ	E.V cover sealer B	1	1	1	1	AC
2-23	PSEL-A415CBE0	E.V cover sealer C	1	1	1	1	AC
2-24	PCOVPA175CBFA	Terminal cover	1	1	1	1	AF
2-25	PCOV-A253CBFA	F lamp cover	1	1	1	1	AC
2-26	PCOV-A254CBFA	R lamp cover	1	1	1	1	AF
2-27	GCOVPA119CBRA	R-cbox cover	1	1	1	1	AS
2-28	HGRL-A184CBRA	Fan louver	1	1	1	1	AU
2-29	GCOV-A162CBFB	Upper hinge cover	-	1	-	-	AD
2-29	GCOV-A162CBFG	Upper hinge cover	1	-	-	-	AD
2-29	GCOV-A162CBFH	Upper hinge cover	-	-	-	1	AD
2-29	GCOV-A162CBFK	Upper hinge cover	-	-	1	-	AD
2-30	PCOV-A255CBFA	Fan cover	2	2	2	2	AD
2-31	JKNB-A033CBFB	R-temp.control knob	1	1	1	1	AD
2-36	PCAP-A006CBFS	Screw cover	-	2	-	-	AB
2-36	PCAP-A006CBFU	Screw cover	-	-	2	-	AB
2-36	PCAP-A006CBFX	Screw cover	2	-	-	-	AB
2-36	PCAP-A006CBFY	Screw cover	-	-	-	2	AB
2-37	PCAP-A056CBFF	Screw cover B	2	2	2	2	AC
2-38	PGID-A156CBFZ	R air guider A	1	1	1	1	AG
2-41	PSEL-B848CBEZ	A-sealer thermo.cap	1	1	1	1	AC
2-49	LSTPPA108CBFA	Chilled stopper	2	2	2	2	AC
2-50	NFANPA019CBFA	Propeller fan 80	1	1	1	1	AM
2-51	PBOX-A121CBFA	F lamp box	1	1	1	1	AF
2-52	PBOX-A122CBFA	R lamp box	1	1	1	1	AM
2-53	LHLD-A536CBFA	R fan motor holder A	1	1	1	1	AF
2-54	LHLD-A537CBFA	R fan motor holder B	1	1	1	1	AE
2-55	HGRL-A186CBFA	Multi louver M	1	1	1	1	AM
2-56	PFPFPB239CBFZ	R-louver insu. M	1	1	1	1	AF
2-57	PSEL-B857CBEZ	A-sealer R-louver	2	2	2	2	AC
2-59	PCOV-A264CBEZ	F lamp box cover	1	1	1	1	AC
2-63	LHLD-A484CBFA	Fan motor holder B	1	1	1	1	AH
2-64	LHLD-A485CBFA	Fan motor holder A	1	1	1	1	AH
2-65	PSEL-B209CBE0	U-sealer handle	2	2	2	2	AB
2-66	PSHEMA132CBP0	Heater cover AL	1	1	1	1	AD

REF. NO.	PART NO.	DESCRIPTION	Q'TY				CODE
			SJ-63L -A2G	SJ-63L -A2B	SJ-63L -A2L	SJ-63L -A2A	
2-67	LPLTMA570CBPZ	Drain support AL	1	1	1	1	AE
2-69	PSEL-B847CBEZ	E.V cover sealer D	2	2	2	2	AC
2-71	PSEL-A552CBE0	Dial sealer	1	1	1	1	AC
2-72	PSEL-B841CBEZ	Ra sealer A	2	2	2	2	AC
2-73	PSEL-B842CBEZ	Ra sealer B	1	1	1	1	AC
2-74	PSEL-B122CBE0	A-sealer thermo.cap.	1	1	1	1	AB
2-77	LHLD-A359CBFA	T-box holder	1	1	1	1	AE
2-78	LPLTMA399CBP0	Dryer support	1	1	1	1	AD
2-79	LBND-A019CBE0	Nylon band	1	1	1	1	AB
2-80	PBOX-A078CBFA	Terminal box	1	1	1	1	AG
2-81	PPIPPA097CBEZ	Drain pipe S	1	1	1	1	AE
2-83	PSEL-B849CBEZ	Ra sealer C	1	1	1	1	AC
2-84	PSEL-B850CBEZ	Ra sealer D	1	1	1	1	AC
2-86	LBND-A026CBE0	Nylon band	1	1	1	1	AD
2-87	LBND-A018CBE0	Fasting band A	1	1	1	1	AP
2-90	HGRL-A179CBFA	F shower duct	1	1	1	1	AM
2-91	HGRL-A180CBFA	F return cover	2	2	2	2	AC
2-93	PCAP-A068CBFA	C sliding cap A	2	2	2	2	AC
2-95	NROL-A027CBEZ	V roller	2	2	2	2	AC
2-96	LHLD-A535CBFA	Shaft holder	2	2	2	2	AC
2-97	LPIN-A178CB1Z	Shaft	2	2	2	2	AC
2-98	LHLD-A504CBE0	SL-3N Clip	1	1	1	1	AD
2-99	GCOV-A192CBFA	Top cover	1	-	-	-	AC
2-99	GCOV-A192CBFB	Top cover	-	1	-	-	AK
2-99	GCOV-A192CBFC	Top cover	-	-	-	1	AD
2-99	GCOV-A192CBFF	Top cover	-	-	1	-	AC
2-105	PSEL-B896CBEZ	A-sealer FS-A	1	1	1	1	AC
2-106	PSEL-B897CBEZ	A-sealer FS-B	2	2	2	2	AC

DOOR PARTS

3-5	FDORFB299CBKZ	F-door assembly	1	-	-	-	BK
3-5	FDORFB306CBKZ	F-door assembly	-	1	-	-	BM
3-5	FDORFB307CBKZ	F-door assembly	-	-	-	1	BK
3-5	FDORFB313CBKZ	F-door assembly	-	-	1	-	BL
3-5-1	LSTPPA107CBFA	Fd stopper spring R	1	1	1	1	AD
3-5-2	NBRGPA022CBFA	Nylon bearing 3S	2	2	2	2	AC
3-5-3	PCOV-A251CBFA	Dc cover FR	1	-	-	-	AC
3-5-3	PCOV-A251CBFB	Dc cover FR	-	1	-	-	AC
3-5-3	PCOV-A251CBFC	Dc cover FR	-	-	-	1	AC
3-5-3	PCOV-A251CBFF	Dc cover FR	-	-	1	-	AC
3-6	FPACGA309CBKZ	F-door packing	1	1	1	1	AX
3-7	HDECQA384CBFA	Handle trim FL	1	1	1	-	AD
3-7	HDECQA384CBFB	Handle trim FL	-	-	-	1	AG
3-8	JHNDPA117CBFA	Door handle FL	1	-	-	-	AK
3-8	JHNDPA117CBFB	Door handle FL	-	1	-	-	AM
3-8	JHNDPA117CBFC	Door handle FL	-	-	-	1	AN
3-8	JHNDPA117CBFF	Door handle FL	-	-	1	-	AP
3-9	PCAP-A067CBFA	Screw cover HD	10	-	-	-	AC
3-9	PCAP-A067CBFB	Screw cover HD	-	10	-	-	AC
3-9	PCAP-A067CBFC	Screw cover HD	-	-	-	10	AD
3-9	PCAP-A067CBFF	Screw cover HD	-	-	10	-	AC
3-15	FDORRB173CBKZ	R-door assembly	1	-	-	-	BQ
3-15	FDORRB174CBKZ	R-door assembly	-	1	-	-	BQ
3-15	FDORRB176CBKZ	R-door assembly	-	-	-	1	BP
3-15	FDORRB182CBKZ	R-door assembly	-	-	1	-	BR
3-15-1	LSTP-A058CBM0	R-door stopper R	1	1	1	1	AF
3-15-2	LSTPPA084CBFA	RD-stopper spring R	1	1	1	1	AD
3-15-3	PCOV-A252CBFA	Dc cover RR	1	-	-	-	AC
3-15-3	PCOV-A252CBFB	Dc cover RR	-	1	-	-	AC
3-15-3	PCOV-A252CBFC	Dc cover RR	-	-	-	1	AC
3-15-3	PCOV-A252CBFF	Dc cover RR	-	-	1	-	AC
3-17	FPACGA314CBKZ	R-door packing	1	1	1	1	AY
3-18	HDECQA385CBFA	Handle trim RL	1	1	1	-	AG
3-18	HDECQA385CBFB	Handle trim RL	-	-	-	1	AG
3-19	JHNDPA118CBFA	Door handle RL	1	-	-	-	AK
3-19	JHNDPA118CBFB	Door handle RL	-	1	-	-	AM
3-19	JHNDPA118CBFC	Door handle RL	-	-	-	1	AN
3-19	JHNDPA118CBFF	Door handle RL	-	-	1	-	AP
3-25	FBDGDA280CBYZ	Badge assembly	1	1	1	1	AY

OTHER PARTS

4-1	LBND-A023CBE0	L-band C	4	4	4	4	AC
4-3	LX-VZA003CBE0	Special screw	2	2	2	2	AB
4-10	QTAN-A013CBE0	Solderless term. A	4	4	4	4	AH
4-15	LX-BZ0202JBE0	Special screw	1	1	1	1	AA
4-17	LX-WZA003CBE0	Washer	4	4	4	4	AA
4-18	LX-BZA076CBEZ	Handle screw	10	10	10	10	AC

REF. NO.	PART NO.	DESCRIPTION	Q'TY				CODE
			SJ-63L -A2G	SJ-63L -A2B	SJ-63L -A2L	SJ-63L -A2A	

ATTACHMENT PARTS

5-1	UPOK-A166CBRA	Bottle pocket	2	2	2	2	AN
5-3	UPOK-A168CBRA	F door pocket	2	2	2	2	AP
5-4	UPOK-A165CBRA	R door pocket	1	1	1	1	AN
5-5	UTNA-A282CBFB	Egg tray	2	2	2	2	AG
5-6	FSRA-A193CBYZ	Ice cube maker	1	1	1	1	AS
5-9	FSRA-A194CBKZ	F shelf assembly	1	1	1	1	AY
5-13	HGRL-A178CBFA	Ventilating grille	1	-	-	-	AG
5-13	HGRL-A178CBFB	Ventilating grille	-	1	-	-	AM
5-13	HGRL-A178CBFC	Ventilating grille	-	-	-	1	AN
5-13	HGRL-A178CBFF	Ventilating grille	-	-	1	-	AN
5-14	USRA-A252CBFA	Drain pan	1	1	1	1	AN
5-15	UYOK-A330CBFA	Fruit case	1	1	1	1	AW
5-16	UYOK-A331CBFA	Vegetable case	1	1	1	1	AZ
5-17	UYOK-A328CBFA	Ice storage box	1	1	1	1	AF
5-18	UYOK-A329CBFA	Chilled case	1	1	1	1	AX
5-19	GDORPA066CBRA	Chilled door	1	1	1	1	AP
5-24	FTNA-A301CBKZ	R glass shelf assembly	2	2	2	2	BC
5-25	FTNA-A302CBKZ	V glass shelf assembly	1	1	1	1	BC
5-26	PCAP-A076CBFA	Venti.grille cap	1	-	-	-	AC
5-26	PCAP-A076CBFB	Venti.grille cap	-	1	-	-	AC
5-26	PCAP-A076CBFC	Venti.grille cap	-	-	-	1	AD
5-26	PCAP-A076CBFF	Venti.grille cap	-	-	1	-	AC
5-28	PCAP-A069CBFA	V sliding cap L	1	1	1	1	AC
5-29	PCAP-A070CBFA	V sliding cap R	1	1	1	1	AC
5-31	LRALPA132CBFA	Ice tray holder L	1	1	1	1	AF
5-32	LRALPA133CBFA	Ice tray holder R	1	1	1	1	AF
5-33	LRALPA134CBFA	Ice tray holder B	1	1	1	1	AF
5-34	PCUP-A009CBFA	Water cup	1	1	1	1	AD
5-35	UPOKPA251CBFA	Tube stand	2	2	2	2	AC
5-36	PCOV-A259CBFA	Case cover	1	1	1	1	AH
5-37	UPOK-A167CBRA	Utility case pocket	1	1	1	1	AM

CYCLE PARTS

6-1	PCMPLA196CBE0	Compressor	1	1	1	1	BX
6-2	PSPAGA028CBE0	Rubber grommet	4	4	4	4	AD
6-3	FCONSA077CBKZ	Sub. condenser assembly	1	1	1	1	AX
6-3-1	PCOV-A256CBFA	Pipe protector L	1	1	1	1	AF
6-3-2	PCOV-A257CBFA	Pipe protector R	1	1	1	1	AF
6-4	FFRM-A112CBKZ	Base frame assembly	1	1	1	1	AG
6-5	FDRY-A006CBK0	Dryer assembly	1	1	1	1	AX
6-6	PCLI-A035CBE0	Clip	1	1	1	1	AC
6-9	PSPAFA020CBE0	Sleeve	4	4	4	4	AB
6-11	PPIPCA357CBEZ	S.p connector	1	1	1	1	AK
6-15	PGUM-A002CBF0	Absorbent rubber B	1	1	1	1	AH
6-18	PPIPCA252CBE0	Charge pipe	2	2	2	2	AD
6-21	PCOVPA165CBE0	Terminal cover	1	1	1	1	AF
6-27	PSEL-B899CBEZ	S-sealer	2	2	2	2	AC
6-28	PKYU-A143CBEZ	S-butyl	1	1	1	1	AD
6-29	PKYU-A036CBE0	SP-butyl D-poy	1	1	1	1	AP
6-30	PKYU-A098CBE0	Compressor butyl	1	1	1	1	AG

MISCELLANEOUS

90-1	TINS-A490CBRZ	Operation manual	1	1	1	1	AG
90-2	TLAB-A092CBR0	Lamp label	1	1	1	1	AD
90-3	SPAKCI777YDEZ	Packing case 63L	1	1	1	1	BC
90-5	TLAB-A897CBEZ	Case label A2G	4	-	-	-	AC
90-5	TLAB-A916CBEZ	Case label A2B	-	4	-	-	AC
90-5	TLAB-A927CBEZ	Case label A2L	-	-	4	-	AC
90-5	TLAB-A937CBEZ	Case label A2A	-	-	-	4	AB
90-6	CPADBA765YDKZ	Bottom pad assembly	1	1	1	1	AY
90-7	CPADBA764YDKZ	Top pad assembly	1	1	1	1	AR
90-8	TLAB-A876CBRZ	Warning label	1	1	1	1	AC

HOW TO ORDER REPLACEMENT PARTS

To have your order filled promptly and correctly, please furnish the following information.

- | | |
|-----------------|----------------|
| 1. MODEL NUMBER | 2. REF. NO. |
| 3. PART NO. | 4. DESCRIPTION |

REPLACEMENT PARTS LIST(SJ-68L-A2G/A2B/A2L/A2A)

REF. NO.	PART NO.	DESCRIPTION	Q'TY				CODE
			SJ-68L -A2G	SJ-68L -A2B	SJ-68L -A2L	SJ-68L -A2A	

ELECTRIC PARTS

1-1	RTHM-A097CBEZ	F-thermostat	1	1	1	1	AX
1-2	RSTT-A144CBE0	Starting relay	1	1	1	1	AW
1-3	QSWTDA035CBE0	Defrost timer	1	1	1	1	BB
1-4	PDMP-A046CBEZ	Damper thermo	1	1	1	1	AX
1-5	FTHM-A028CBKZ	Defrost thermo.assembly	1	1	1	1	AN
1-6	RMOTRA040CBE0	Fan motor	1	1	1	1	AZ
1-7	QSOCAA074CBEZ	Lamp socket	1	1	1	1	AP
1-8	RLMP-A012CBE0	Lamp	1	1	1	1	AH
1-9	QACC-A101CBE0	Source cord	1	1	1	1	AN
1-10	QSW-PA090CBZA	Door switch	1	1	1	1	AS
1-11	RHOG-A105CBE0	Protector	1	1	1	1	AV
1-17	FFS-TA055CBKZ	Fuse assembly	1	1	1	1	AL
1-20	FW-VZA144CBEZ	Lead ev-cover assembly	1	1	1	1	AK
1-21	FHETBA149CBEZ	Def.heater assembly	1	1	1	1	BB
1-22	FCNW-A514CBK0	Relay cord s assembly	1	1	1	1	AN
1-25	QTAN-A032CBE0	Terminal block	1	1	1	1	AE
1-27	RMOTRA061CBEZ	Fan motor	1	1	1	1	AW
1-28	RLMP-A029CBEZ	Lamp 15W	1	1	1	1	AH
1-29	QSOCAA072CBEZ	Lamp socket	1	1	1	1	AN
1-30	FTHM-A029CBKZ	R fan thermo assembly	1	1	1	1	AQ

MECHANICAL PARTS

2-2	JKNB-A036CBFB	F-temp. control knob	1	1	1	1	AD
2-4	LPLTMA568CBEZ	Fl plate AL.	1	1	1	1	AF
2-7	FLEGPA077CBKZ	Leg holder L assembly	1	1	1	1	AQ
2-7-1	FAJS-A009CBK0	Adjustable leg assembly	2	2	2	2	AD
2-7-2	LHLD-A533CBPZ	Leg holder L	1	1	1	1	AL
2-8	FLEGPA078CBKZ	Leg holder R assembly	1	1	1	1	AQ
2-8-2	LHLD-A534CBPZ	Leg holder R	1	1	1	1	AP
2-10	PSPAVA083CBEA	Upper hinge spacer	1	1	1	1	AD
2-11	PSPAVA084CBEA	Bottom hinge spacer	1	1	1	1	AC
2-12	PSPAVA075CBEA	Center hinge spacer	1	1	1	1	AD
2-13	DHNG-A363CBMZ	Upper hinge assembly	1	1	1	1	AE
2-14	DHNG-A365CBMZ	Bottom hinge R assembly	1	1	1	1	AE
2-15	DHNG-A364CBMZ	Center hinge R assembly	1	1	1	1	AF
2-16	GCOV-A191CBFZ	E.V cover	1	1	1	1	AS
2-17	LCRA-A010CBE0	Fan clamp	2	2	2	2	AD
2-19	LHLD-A389CBF0	Motor cushion	2	2	2	2	AF
2-20	NFANPA020CBFA	Propeller fan 100	1	1	1	1	AE
2-21	PSEL-B845CBEZ	E.V cover sealer A	1	1	1	1	AC
2-22	PSEL-B846CBEZ	E.V cover sealer B	1	1	1	1	AC
2-23	PSEL-A415CBE0	E.V cover sealer C	1	1	1	1	AC
2-24	PCOVPA175CBFA	Terminal cover	1	1	1	1	AF
2-25	PCOV-A253CBFA	F lamp cover	1	1	1	1	AC
2-26	PCOV-A254CBFA	R lamp cover	1	1	1	1	AF
2-27	GCOVPA119CBRA	R-cbox cover	1	1	1	1	AS
2-28	HGRL-A184CBRA	Fan louver	1	1	1	1	AU
2-29	GCOV-A162CBFB	Upper hinge cover	-	1	-	-	AD
2-29	GCOV-A162CBFG	Upper hinge cover	1	-	-	-	AD
2-29	GCOV-A162CBFH	Upper hinge cover	-	-	-	1	AD
2-29	GCOV-A162CBFK	Upper hinge cover	-	-	1	-	AD
2-30	PCOV-A255CBFA	Fan cover	2	2	2	2	AD
2-31	JKNB-A033CBFB	R-temp.control knob	1	1	1	1	AD
2-36	PCAP-A006CBFS	Screw cover	-	2	-	-	AB
2-36	PCAP-A006CBFU	Screw cover	-	-	2	-	AB
2-36	PCAP-A006CBFX	Screw cover	2	-	-	-	AB
2-36	PCAP-A006CBFY	Screw cover	-	-	-	2	AB
2-37	PCAP-A056CBFF	Screw cover B	2	2	2	2	AC
2-38	PGID-A156CBFZ	R air guider A	1	1	1	1	AG
2-41	PSEL-B848CBEZ	A-sealer thermo.cap	1	1	1	1	AC
2-49	LSTPPA108CBFA	Chilled stopper	2	2	2	2	AC
2-50	NFANPA019CBFA	Propeller fan 80	1	1	1	1	AM
2-51	PBOX-A121CBFA	F lamp box	1	1	1	1	AF
2-52	PBOX-A122CBFA	R lamp box	1	1	1	1	AM
2-53	LHLD-A536CBFA	R fan motor holder A	1	1	1	1	AF
2-54	LHLD-A537CBFA	R fan motor holder B	1	1	1	1	AE
2-55	HGRL-A181CBFA	Multi louver L	1	1	1	1	AN
2-56	PFPFPB233CBFZ	R-louver insu. L	1	1	1	1	AG
2-57	PSEL-B843CBEZ	A-sealer R-louver	2	2	2	2	AC
2-59	PCOV-A264CBEZ	F lamp box cover	1	1	1	1	AC
2-63	LHLD-A484CBFA	Fan motor holder B	1	1	1	1	AH
2-64	LHLD-A485CBFA	Fan motor holder A	1	1	1	1	AH
2-65	PSEL-B209CBE0	U-sealer handle	2	2	2	2	AB
2-66	PSHEMA132CBP0	Heater cover AL	1	1	1	1	AD

REF. NO.	PART NO.	DESCRIPTION	Q'TY				CODE
			SJ-68L -A2G	SJ-68L -A2B	SJ-68L -A2L	SJ-68L -A2A	
2-67	LPLTMA570CBPZ	Drain support AL	1	1	1	1	AE
2-69	PSEL-B847CBEZ	E.V cover sealer D	2	2	2	2	AC
2-71	PSEL-A552CBE0	Dial sealer	1	1	1	1	AC
2-72	PSEL-B841CBEZ	RA sealer A	2	2	2	2	AC
2-73	PSEL-B842CBEZ	RA sealer B	1	1	1	1	AC
2-74	PSEL-B122CBE0	A-sealer thermo.cap.	1	1	1	1	AB
2-77	LHLD-A359CBFA	T-box holder	1	1	1	1	AE
2-78	LPLTMA399CBP0	Dryer support	1	1	1	1	AD
2-79	LBND-A019CBE0	Nylon band	1	1	1	1	AB
2-80	PBOX-A078CBFA	Terminal box	1	1	1	1	AG
2-81	PPIPPA097CBEZ	Drain pipe S	1	1	1	1	AE
2-83	PSEL-B849CBEZ	RA sealer C	1	1	1	1	AC
2-84	PSEL-B850CBEZ	RA sealer D	1	1	1	1	AC
2-86	LBND-A026CBE0	Nylon band	1	1	1	1	AD
2-87	LBND-A018CBE0	Fasting band A	1	1	1	1	AP
2-90	HGRL-A179CBFA	F shower duct	1	1	1	1	AM
2-91	HGRL-A180CBFA	F return cover	2	2	2	2	AC
2-93	PCAP-A068CBFA	C sliding cap A	2	2	2	2	AC
2-95	NROL-A027CBEZ	V roller	2	2	2	2	AC
2-96	LHLD-A535CBFA	Shaft holder	2	2	2	2	AC
2-97	LPIN-A178CB1Z	Shaft	2	2	2	2	AC
2-98	LHLD-A504CBE0	SL-3N Clip	1	1	1	1	AD
2-99	GCOV-A192CBFA	Top cover	1	-	-	-	AC
2-99	GCOV-A192CBFB	Top cover	-	1	-	-	AK
2-99	GCOV-A192CBFC	Top cover	-	-	-	1	AD
2-99	GCOV-A192CBFF	Top cover	-	-	1	-	AC
2-105	PSEL-B896CBEZ	A-sealer FS-A	1	1	1	1	AC
2-106	PSEL-B897CBEZ	A-sealer FS-B	2	2	2	2	AC

DOOR PARTS

3-5	FDORFB299CBKZ	F-door assembly	1	-	-	-	BK
3-5	FDORFB306CBKZ	F-door assembly	-	1	-	-	BM
3-5	FDORFB307CBKZ	F-door assembly	-	-	-	1	BK
3-5	FDORFB313CBKZ	F-door assembly	-	-	1	-	BL
3-5-1	LSTPPA107CBFA	Fd stopper spring R	1	1	1	1	AD
3-5-2	NBRGPA022CBFA	Nylon bearing 3S	2	2	2	2	AC
3-5-3	PCOV-A251CBFA	Dc cover FR	1	-	-	-	AC
3-5-3	PCOV-A251CBFB	Dc cover FR	-	1	-	-	AC
3-5-3	PCOV-A251CBFC	Dc cover FR	-	-	-	1	AC
3-5-3	PCOV-A251CBFF	Dc cover FR	-	-	1	-	AC
3-6	FPACGA309CBKZ	F-door packing	1	1	1	1	AX
3-7	HDECQA384CBFA	Handle trim FL	1	1	1	-	AD
3-7	HDECQA384CBFB	Handle trim FL	-	-	-	1	AG
3-8	JHNDPA117CBFA	Door handle FL	1	-	-	-	AK
3-8	JHNDPA117CBFB	Door handle FL	-	1	-	-	AM
3-8	JHNDPA117CBFC	Door handle FL	-	-	-	1	AN
3-8	JHNDPA117CBFF	Door handle FL	-	-	1	-	AP
3-9	PCAP-A067CBFA	Screw cover HD	10	-	-	-	AC
3-9	PCAP-A067CBFB	Screw cover HD	-	10	-	-	AC
3-9	PCAP-A067CBFC	Screw cover HD	-	-	-	10	AD
3-9	PCAP-A067CBFF	Screw cover HD	-	-	10	-	AC
3-15	FDORRB166CBKZ	R-door assembly	1	-	-	-	BQ
3-15	FDORRB168CBKZ	R-door assembly	-	1	-	-	BR
3-15	FDORRB169CBKZ	R-door assembly	-	-	-	1	BP
3-15	FDORRB175CBKZ	R-door assembly	-	-	1	-	BQ
3-15-1	LSTP-A058CBM0	R-door stopper R	1	1	1	1	AF
3-15-2	LSTPPA084CBFA	RD-stopper spring R	1	1	1	1	AD
3-15-3	PCOV-A252CBFA	Dc cover RR	1	-	-	-	AC
3-15-3	PCOV-A252CBFB	Dc cover RR	-	1	-	-	AC
3-15-3	PCOV-A252CBFC	Dc cover RR	-	-	-	1	AC
3-15-3	PCOV-A252CBFF	Dc cover RR	-	-	1	-	AC
3-17	FPACGA310CBKZ	R-door packing	1	1	1	1	AY
3-18	HDECQA385CBFA	Handle trim RL	1	1	1	-	AG
3-18	HDECQA385CBFB	Handle trim RL	-	-	-	1	AG
3-19	JHNDPA118CBFA	Door handle RL	1	-	-	-	AK
3-19	JHNDPA118CBFB	Door handle RL	-	1	-	-	AM
3-19	JHNDPA118CBFC	Door handle RL	-	-	-	1	AN
3-19	JHNDPA118CBFF	Door handle RL	-	-	1	-	AP
3-25	FBDGDA280CXYZ	Badge assembly	1	1	1	1	AN

OTHER PARTS

4-1	LBND-A023CBE0	L-band C	4	4	4	4	AC
4-3	LX-VZA003CBE0	Special screw	2	2	2	2	AB
4-10	QTAN-A013CBE0	Solderless term. A	4	4	4	4	AH
4-15	LX-BZ0202JBE0	Special screw	1	1	1	1	AA
4-17	LX-WZA003CBE0	Washer	4	4	4	4	AA
4-18	LX-BZA076CBEZ	Handle screw	10	10	10	10	AC

REF. NO.	PART NO.	DESCRIPTION	Q'TY				CODE
			SJ-68L -A2G	SJ-68L -A2B	SJ-68L -A2L	SJ-68L -A2A	

ATTACHMENT PARTS

5-1	UPOK-A166CBRA	Bottle pocket	2	2	2	2	AN
5-3	UPOK-A168CBRA	F door pocket	2	2	2	2	AP
5-4	UPOK-A165CBRA	R door pocket	2	2	2	2	AN
5-5	UTNA-A282CBFB	Egg tray	2	2	2	2	AG
5-6	FSRA-A193CBYZ	Ice cube maker	1	1	1	1	AS
5-9	FSRA-A194CBKZ	F shelf assembly	1	1	1	1	AY
5-13	HGRL-A178CBFA	Ventilating grille	1	-	-	-	AG
5-13	HGRL-A178CBFB	Ventilating grille	-	1	-	-	AM
5-13	HGRL-A178CBFC	Ventilating grille	-	-	-	1	AN
5-13	HGRL-A178CBFF	Ventilating grille	-	-	1	-	AN
5-14	USRA-A252CBFA	Drain pan	1	1	1	1	AN
5-15	UYOK-A330CBFA	Fruit case	1	1	1	1	AW
5-16	UYOK-A331CBFA	Vegetable case	1	1	1	1	AZ
5-17	UYOK-A328CBFA	Ice storage box	1	1	1	1	AF
5-18	UYOK-A329CBFA	Chilled case	1	1	1	1	AX
5-19	GDORPA066CBRA	Chilled door	1	1	1	1	AP
5-24	FTNA-A301CBKZ	R glass shelf assembly	3	3	3	3	BC
5-25	FTNA-A302CBKZ	V glass shelf assembly	1	1	1	1	BC
5-26	PCAP-A076CBFA	Venti.grille cap	1	-	-	-	AC
5-26	PCAP-A076CBFB	Venti.grille cap	-	1	-	-	AC
5-26	PCAP-A076CBFC	Venti.grille cap	-	-	-	1	AD
5-26	PCAP-A076CBFF	Venti.grille cap	-	-	1	-	AC
5-28	PCAP-A069CBFA	V sliding cap L	1	1	1	1	AC
5-29	PCAP-A070CBFA	V sliding cap R	1	1	1	1	AC
5-31	LRALPA132CBFA	Ice tray holder L	1	1	1	1	AF
5-32	LRALPA133CBFA	Ice tray holder R	1	1	1	1	AF
5-33	LRALPA134CBFA	Ice tray holder B	1	1	1	1	AF
5-34	PCUP-A009CBFA	Water cup	1	1	1	1	AD
5-35	UPOKPA251CBFA	Tube stand	2	2	2	2	AC
5-36	PCOV-A259CBFA	Case cover	1	1	1	1	AH
5-37	UPOK-A167CBRA	Utility case pocket	1	1	1	1	AM

CYCLE PARTS

6-1	PCMPLA202CBEZ	Compressor	1	1	1	1	BX
6-2	PSPAGA028CBE0	Rubber grommet	4	4	4	4	AD
6-3	FCONSA077CBKZ	Sub. condenser assembly	1	1	1	1	AX
6-3-1	PCOV-A256CBFA	Pipe protector L	1	1	1	1	AF
6-3-2	PCOV-A257CBFA	Pipe protector R	1	1	1	1	AF
6-4	FFRM-A112CBKZ	Base frame assembly	1	1	1	1	AG
6-5	FDRY-A006CBK0	Dryer assembly	1	1	1	1	AX
6-6	PCLI-A035CBE0	Clip	1	1	1	1	AC
6-9	PSPAFA020CBE0	Sleeve	4	4	4	4	AB
6-11	PPIPICA357CBEZ	S.p connector	1	1	1	1	AK
6-15	PGUM-A002CBF0	Absorbent rubber B	1	1	1	1	AH
6-18	PPIPICA252CBE0	Charge pipe	2	2	2	2	AD
6-21	PCOVPA165CBE0	Terminal cover	1	1	1	1	AF
6-27	PSEL-B899CBEZ	S-sealer	2	2	2	2	AC
6-28	PKYU-A143CBEZ	S-butyl	1	1	1	1	AD
6-29	PKYU-A036CBE0	Sp-butyl d-poy	1	1	1	1	AP
6-30	PKYU-A098CBE0	Compressor butyl	1	1	1	1	AG

MISCELLANEOUS

90-1	TINS-A490CBRZ	Operation manual	1	1	1	1	AG
90-2	TLAB-A092CBR0	Lamp label	1	1	1	1	AD
90-3	SPAKCI775YDEZ	Packing case 68L	1	1	1	1	BC
90-5	TLAB-A897CBEZ	Case label A2G	4	-	-	-	AC
90-5	TLAB-A916CBEZ	Case label A2B	-	4	-	-	AC
90-5	TLAB-A927CBEZ	Case label A2L	-	-	4	-	AC
90-5	TLAB-A937CBEZ	Case label A2A	-	-	-	4	AB
90-6	CPADBA765YDKZ	Bottom pad assembly	1	1	1	1	AY
90-7	CPADBA764YDKZ	Top pad assembly	1	1	1	1	AR
90-8	TLAB-A876CBRZ	Warning label	1	1	1	1	AC

HOW TO ORDER REPLACEMENT PARTS

To have your order filled promptly and correctly, please furnish the following information.

1. MODEL NUMBER
2. REF. NO.
3. PART NO.
4. DESCRIPTION

DOOR PARTS

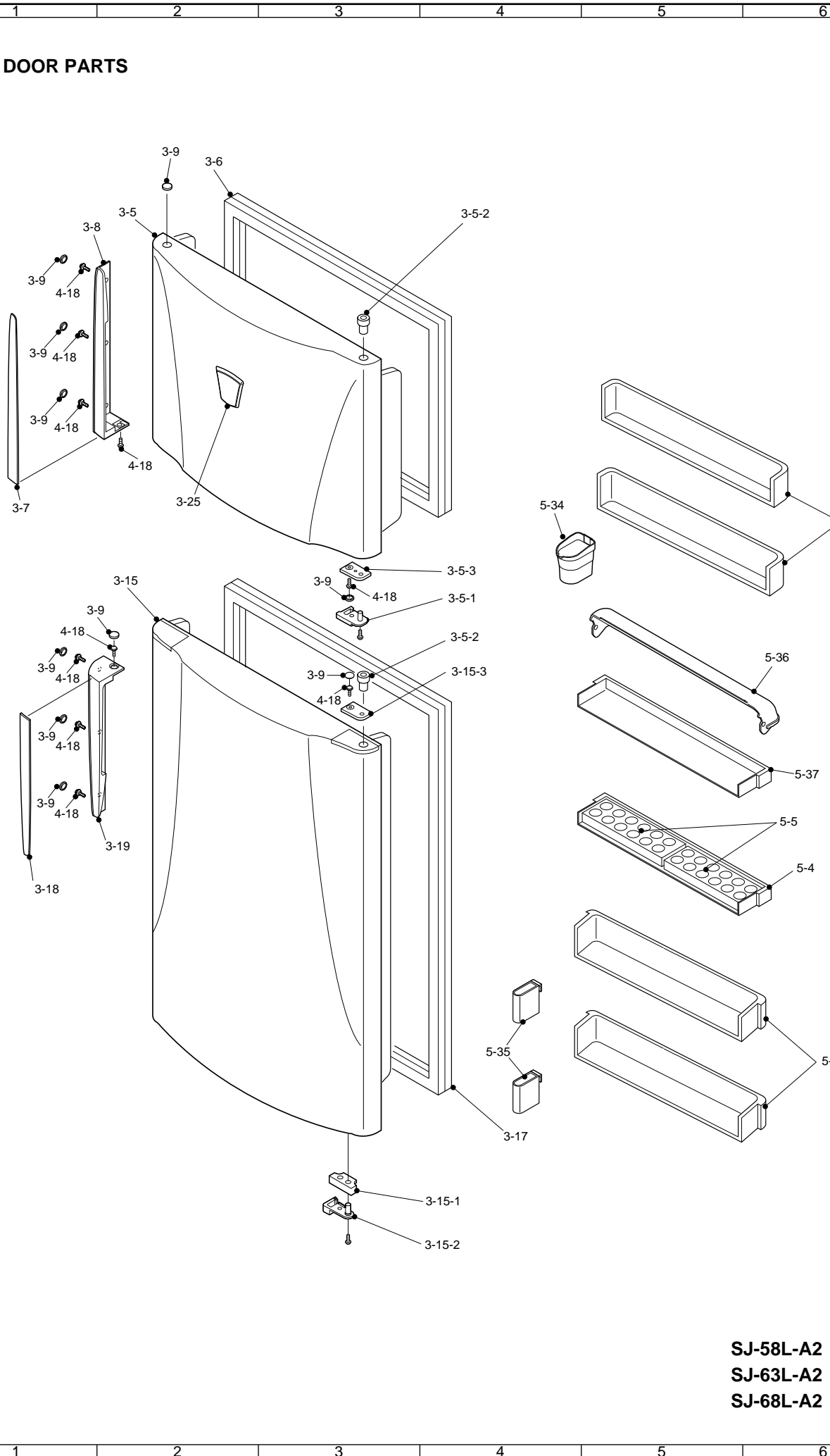

CABINET PARTS

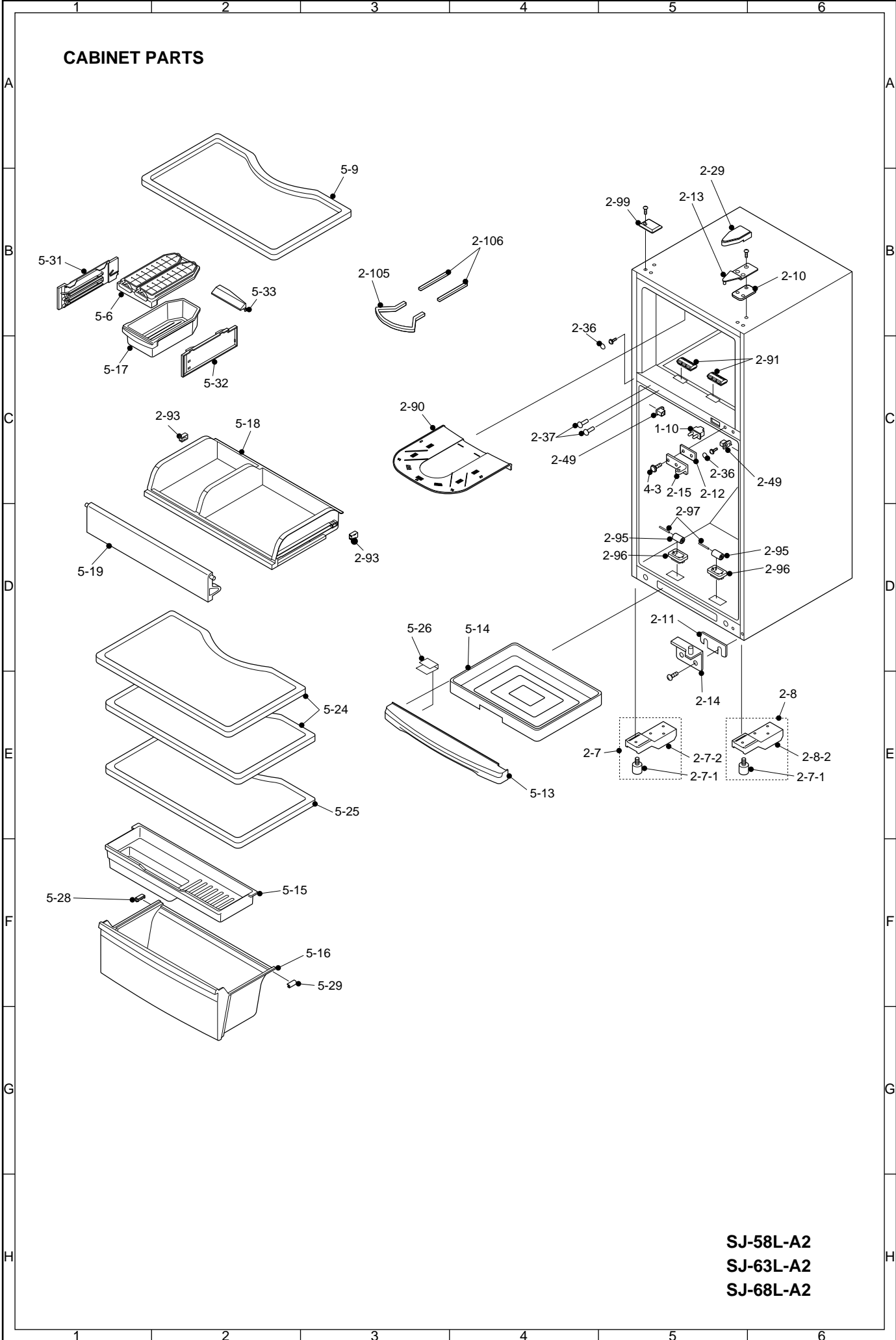

SJ-58L-A2
SJ-63L-A2
SJ-68L-A2

CABINET PARTS

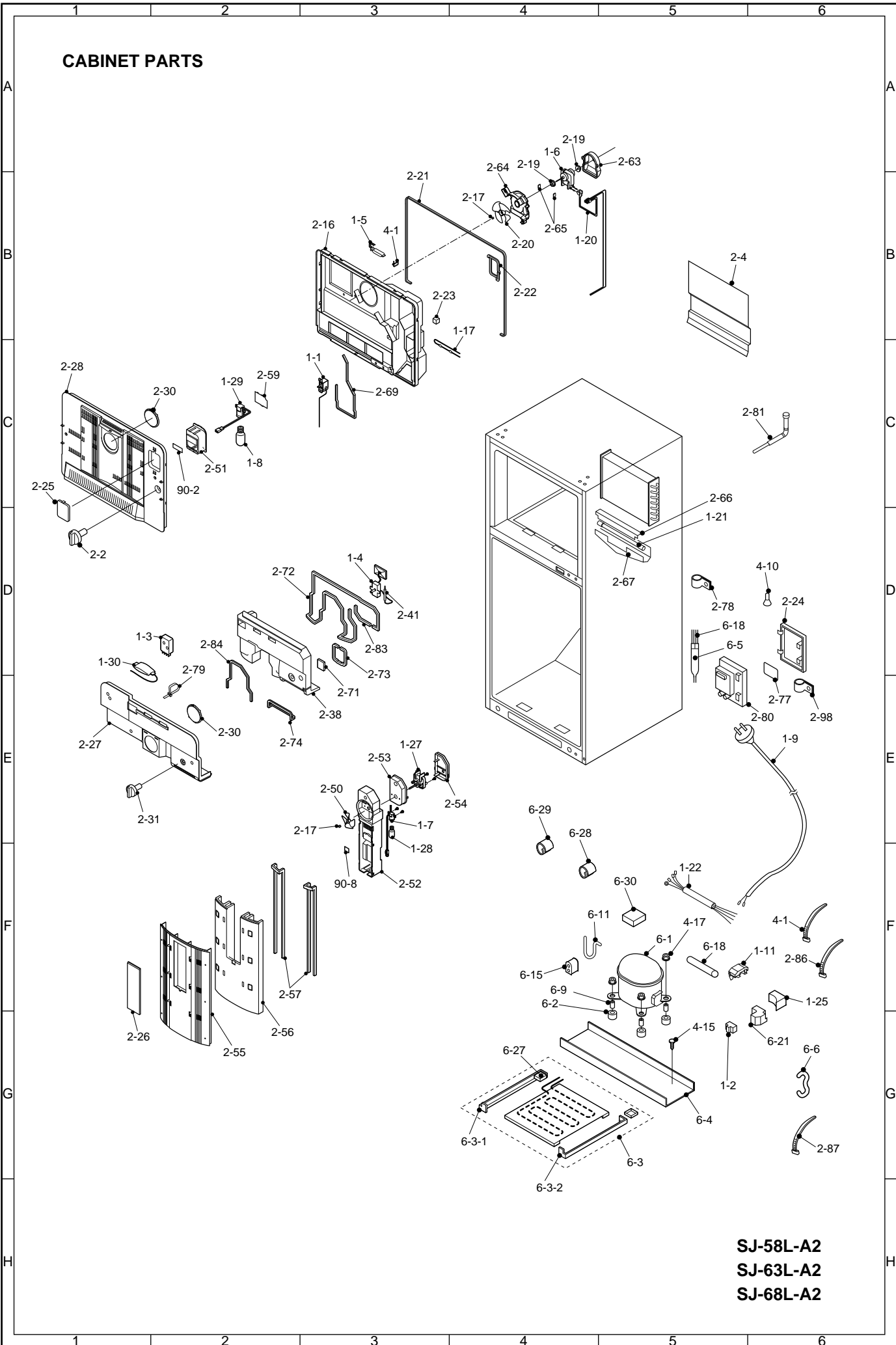

SJ-58L-A2
SJ-63L-A2
SJ-68L-A2

SHARP