

SMITHCO

Wayne, Pennsylvania 19087

PARTS & SERVICE MANUAL

SWEEP STAR 60

**GAS & DIESEL with Electric Clutch
Models 76-000-C and 77-100-C**

Starting Serial #: D or G 1745

July, 2004

SMITHCO PRODUCT SUPPORT

1-800-891-9435

Hwy SS and Poplar Avenue, Cameron WI 54822

E-mail: productsupport@smithco.com

CONTENTS

Introduction

Service

Diagrams

Parts

Accessories

Reference

Introduction	1-3
Safe Practices	2
Specifications	3
Optional Equipment	3
Service	4-11
Maintenance	4-6
Service Chart Kohler Command 25 hp	7
Service Chart Kubota Diesel 18.8 hp	8
End User's Service Chart	9
Adjustments	10
Storage	10
Notes	11
Diagrams	12-17
Diesel Wiring Diagram	12-13
Gas Wiring Diagram	14-15
Hydraulic Diagram	16-17
Parts	18-63
Body and Frame	18-19
Roll Over Protection (ROPS)	20-21
Steering	22-23
Front Fork	24-25
Gasoline Linkage	26-27
Diesel Linkage	28-29
Gas Console	30-31
Diesel Console	32-33
Fuel Tank and Oil Tank	34-35
Oil Filter	36-37
Hydraulic Lift Cylinder	36-37
Reel Lift Cylinder	38-39
Tailgate Cylinder	38-39
Kohler Gas Engine and Exhaust	40-41
Kubota Diesel Engine and Exhaust	42-45
Electric Clutch Driven Belt Drive	46-47
Finger Reel	48-49
Rear Axle	50-51
Hopper	52-53
Tailgate	54-55
77-239 Eaton Hydrostatic Pump	56-57
76-197 Eaton Gear Pump	58-59
76-238 Rear Wheel Motor	60-61
76-023 3-Bank Hydraulic Valve	62-63
Accessories	64-65
76-271 Dust/Dirt Filtration Pack	64-65
Reference	67-68
Decal List	67
Quick Reference Replacement Parts	68

Thank you for purchasing a **SMITHCO** product.

Read this manual and all other manuals pertaining to the Sweep Star 60 carefully as they have safety, operating, assembly and maintenance instructions. Failure to do so could result in personal injury or equipment damage.

Keep manuals in a safe place after operator and maintenance personnel have read them. Right and left sides are from the operator's seat, facing forward.

All **SMITHCO** machines have a Serial Number and Model Number. Both numbers are needed when ordering parts. The serial number plate on the Sweep Star 60 is located on the left front main frame, in front of the engine. Refer to engine manual for placement of engine serial number.

For easy access record your Serial and Model numbers here.

SMITHCO		DATE OF MFG.
WAYNE, PENNSYLVANIA 19087 USA 610-688-4009 Fax 610-688-6069		<input type="text"/>
SERIAL NO.	kW/hp	
<input type="text"/>	<input type="text"/>	
MODEL NO.	kg/lb	
<input type="text"/>	<input type="text"/>	

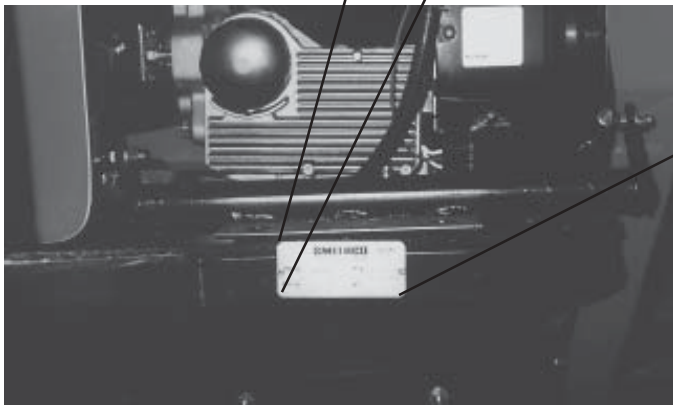

Information needed when ordering replacement parts:

1. Model Number of machine.
2. Serial Number of machine.
3. Name and Part Number of part.
4. Quantity of parts.

SAFE PRACTICES

- It is your responsibility to read this manual and all publications associated with this machine (engine, accessories and attachments).
- Never allow anyone to operate or service the machine or its attachments without proper training and instructions. Never allow minors to operate any equipment.
 - Learn the proper use of the machine, the location and purpose of all the controls and gauges before you operate the equipment. Working with unfamiliar equipment can lead to accidents.
 - Wear all the necessary protective clothing and personal safety devices to protect your head, eyes, ears, hands and feet. Operate the machine only in daylight or in good artificial light.
 - Inspect the area where the equipment will be used. Beware of overhead obstructions and underground obstacles. Stay alert for hidden hazards.
 - Never operate equipment that is not in perfect working order or without decals, guards, shields, or other protective devices in place.
 - Never disconnect or bypass any switch.
 - Carbon monoxide in the exhaust fumes can be fatal when inhaled, never operate a machine without proper ventilation.
 - Fuel is highly flammable, handle with care.
 - Keep engine clean. Allow the engine to cool before storing and always remove the ignition key.
 - After engine has started, machine must not move. If movement is evident, the neutral mechanism is not adjusted correctly. Shut engine off and readjust so the machine does not move when in neutral position.
 - Never use your hands to search for oil leaks. Hydraulic fluid under pressure can penetrate the skin and cause serious injury.
 - This machine demands your attention. To prevent loss of control or tipping of the vehicle:
 - Use extra caution in backing up the vehicle. Ensure area is clear.
 - Do not operate on a slope greater than 10°. Pay careful attention to the inclinometer on your machine.
 - Do not stop or start suddenly on sloped surfaces.
 - Reduce speed on slopes and in all turns. Use caution when changing directions on all surfaces.
 - Do not change directions of travel on any slope.
 - Do not operate debris hopper lift or tailgate while on slopes.
 - Stay alert for holes in the terrain and other hidden hazards.
 - Before leaving operator's position for any reason:
 - Disengage all drives.
 - Lower all attachments to the ground.
 - Set park brake.
 - Shut engine off and remove the ignition key.
 - Keep hands, feet and clothing away from moving parts. Wait for all movement to stop before you clean, adjust or service the machine.
 - Keep the area of operation clear of all bystanders.
 - Never carry passengers.
 - Stop engine before making repairs/adjustments or checking/adding oil to the crankcase.
 - Use parts and materials supplied by SMITHCO only. Do not modify any function or part.
 - Do not remove the radiator cap when the engine is hot. When cooled, loosen cap slightly to the stop to relieve any pressure before removing the cap completely.

These machines are intended for operation by well trained persons performing professional maintenance on golf courses, sports turf, and any other area maintained turf and related trails, paths and lots. No guaranty as to the suitability for any task is expressed or implied.



SPECIFICATIONS FOR SWEEP STAR 60 GAS & DIESEL

WEIGHTS AND DIMENSIONS

Length	129" (328 cm)
Width	74.5" (179 cm)
Height with Hopper Down	66" (168 cm)
Height with Hopper Up	127" (323 cm)
Wheel Base	68.5" (174 cm)
Weight	2200 lbs (998 kg)

SOUND LEVEL

At ear level
At 3 ft (0.914 m)
At 30 ft (9.14 m)

GAS ENGINE

92 dB
86 dB
64 dB
GAS
Kohler
Command CH25S
PA-68525
25 Hp (18 kw)
Unleaded 87 Octane
Gasoline Minimum

DIESEL ENGINE

98 dB
96 dB
74 dB
DIESEL
Kubota
D 722B-1
18.8 Hp (14 kw)
No. 2 Diesel

ENGINE

Make
Model#
Type / Spec#
Horsepower
Fuel
Cooling System
Lubrication System
Alternator

15 Amp
Air Cooled
Full Pressure
15 Amp

Liquid Cooled
Full Pressure
15 Amp

Tire & Wheels

Front: One 18 x 9.50 x 8 Multi-rib (20 psi; 1.4 bar)
 Front tire and wheel fluid filled to 50 lbs. total. 28 pints of windshield washer fluid or equivalent.
 Rear: Two 24 x 13.00 x 12 Super Soft (18 psi; 1.3 bar)
 Castor: 9 x 3.5 - 4 (20 psi; 1.4 bar)

SPEED

Forward Speed	0 to 12 m.p.h. (0-19 kph)
Reverse Speed	0 to 4 m.p.h. (0-6 kph)

BATTERY

Automotive type 45 -12 volt
BCI Group
Size 45
Cold Cranking Amps
480 minimum
Ground Terminal Polarity
Negative (-)
Maximum Length
9" (23 cm)
Maximum Width
5.38" (14 cm)
Maximum Height
9" (23 cm)

FLUID CAPACITY

Crankcase Oil	See Engine Manual
Fuel	5 gallon (19 liters)
Hydraulic Fluid	5 gallon (19 liters)
Cooling	Kubota approximately 1 gallon (3.8 liters)
Grade of Hydraulic Fluid	SAE 10W-40 API Service SJ or higher Motor Oil

OPTIONAL EQUIPMENT

- 77-328 60" Brush Kit
- 76-329 60" Finger Reel Kit
- 76-271 Filtration Pack
- 77-218 Triple Castor Wheel Kit



MAINTENANCE

LUBRICATION

Use No. 2 General Purpose Lithium Base Grease and lubricate every 100 hours. The Sweep Star 60 has ten grease fittings.

- One on the outside of each tower.
- One on the center of park brake relay on rear axle.
- One on hydrostatic pedal under the floorboard.
- One on the pillow block bearing on each end of finger reel.
- One on castor wheel mount bracket.
- One on hydrostatic forward and reverse relay.
- One on reel clutch belt tightener.
- One on rod end of the tailgate cylinder.

Every 500 hours of operation, separate the hydrostatic pump from the engine. Clean the splined areas and lightly grease the male portion of the pump spline. Use either Dow Corning® G-N Metal Assembly Paste or #77 Assembly Paste (Kohler # 25 357 12-s).

As you remount the pump to the engine, be certain the mating surface are clean and free of any foreign material and that the pump is correctly aligned.

HYDRAULIC OIL

1. Use SAE 10W-40 API Service SJ or higher motor oil.
2. For proper warranty, change oil every 500 hours or annually, whichever is first and change the filter after the first 20 hours, then at 100 hours, then every 250 hours thereafter.
3. The oil level should be 2" to 2 1/2" from top of the tank when fluid is cold. Do not overfill.
4. After changing oil and/or filter, run the machine for a few minutes. Check oil level and for leaks.
5. Always use caution when filling hydraulic oil tank or checking level to keep system free of contaminants. Check and service more frequently when operating in extremely cold, hot or dusty conditions.
6. If natural color of fluid is now black or smells burnt, it is possible that an overheating problem exists.
7. If fluid becomes milky, water contamination may be a problem.
8. If either of the above conditions happen, change oil and filter immediately after fluid is cool and find cause. Take fluid level readings when system is cold.
9. In extreme temperatures you can use straight weight oil. We recommend SAE 30W API Service SJ or higher when hot (above 90°F (33°C)) and SAE 10W API Service SJ or higher when cold (below 32°F (0°C)) ambient temperature. Use either motor oil or hydraulic oil, but do not mix.
10. Oil being added to the system must be the same as what is already in the tank. Mark tank fill area as to which type you put in.

TIRE PRESSURE

Caution must be used when inflating a low tire to recommended pressure. Over inflating can cause tires to explode. Front tires and castor wheel should be 20 psi (1.4 bar), rear tires should be 18 psi (1.3 bar) maximum. Improper inflation will reduce tire life considerably.

ENGINE OIL FOR KOHLER

Change and add oil according to charts below. Do not overfill. Use a high quality detergent oil. For Kohler engine use oil classified "For Service SJ or higher" SAE 30 oil. For Kubota Diesel engine use oil classified "For Service CC, CD or CE" API oil. Use no special additives with recommended oils. Do not mix oil with gasoline.

SAE 30 oil, if used below 40° F (4° C), will result in hard starting and possible engine bore damage due to inadequate lubrication.

SAE Viscosity Grades

Kohler Gas Engine

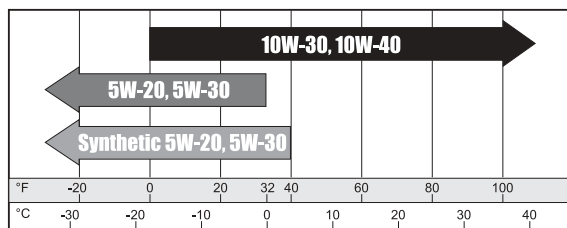

Kubota Diesel Engine

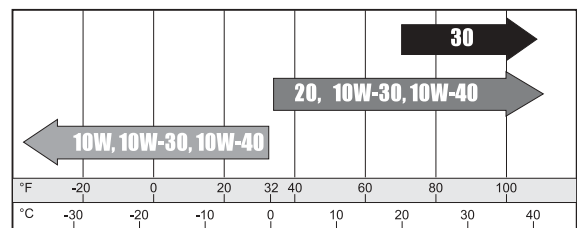

Starting Temperature Range Anticipated Before Next Oil Change

TOWING

When it is necessary to move the Sweep Star 60 without engine running, the bypass valve built into hydrostatic pump must be "open" by turning it counterclockwise. The valve is located on bottom left of pump. An "open" valve allows fluid to pass through the wheels freely. When normal, driven, operation is desired, valve should be closed by turning it clockwise. Failure to "close" the valve with engine running means no power to wheels.

BATTERY

Batteries normally produce explosive gases which can cause personal injury. Do not allow flames, sparks or any ignited object to come near the battery. When charging or working near battery, always shield your eyes and always provide proper ventilation.

Battery cable should be disconnected before using "Fast Charge".

Charge battery at 15 amps for 10 minutes or 7 amps for 30 minutes. Do not exceed the recommended charging rate. If electrolyte starts boiling over, decrease charging.

Always remove grounded (-) battery clamp first and replace it last. Avoid hazards by:

1. Filling batteries in well-ventilated areas.
2. Wear eye protection and rubber gloves.
3. Avoid breathing fumes when electrolyte is added.
4. Avoid spilling or dripping electrolyte.



Battery Electrolyte is an acidic solution and should be handled with care. If electrolyte is splashed on any part of your body, flush all contact areas immediately with liberal amounts of water. Get medical attention immediately.

FILTER PACK

Filter pack may be cleaned by shaking or spraying off with low pressure water. Filter will disintegrate if high pressure is used on it.

MAINTENANCE (CONTINUED)

WHEEL MOUNTING PROCEDURE

REAR WHEELS

1. Set park brake. Turn machine off and remove key.
2. Block one of the other wheels.
3. Loosen nuts slightly on wheel to be removed.
4. Jack up machine being careful not to damage underside of machine.
5. Remove nuts, remove wheel.
5. Place new wheel on hub lining up bolt holes.
6. Torque nuts to 64-74 ft/lb (87-100 Nm) using a cross pattern. Torque again after first 10 hours and every 200 hours thereafter.
7. Lower machine to ground and remove blocks and jack.

FRONT WHEEL

1. Set park brake. Turn machine off and remove key.
2. Block one of the other wheels.
3. Remove cotter pins from each end of the axle.
4. Remove axle nuts, machine bushings and axle locks.
5. Jack up front of machine being careful not to damage underside of machine.
6. Wheel and axle will come out of slots in the u-bracket, pull wheel forward.
7. Place new wheel on hub lining up bolt holes.
8. Torque nuts to 64-74 ft/lb (87-100 Nm) using a cross pattern. Torque again after first 10 hours and every 200 hours thereafter.
9. Lower machine to ground and remove blocks and jack.

JUMPSTARTING



Use of booster battery and jumper cables. Particular care should be used when connecting a booster battery. Use proper polarity in order to prevent sparks.

To jump start (negative grounded battery):

1. Shield eyes.
2. Connect ends of one cable to positive (+) terminals of each battery, first (A) then (B).
3. Connect one end of other cable to negative (-) terminal of "good" battery (C).
4. Connect other end of cable (D) to engine block on unit being started (NOT to negative (-) terminal of battery)

To prevent damage to other electrical components on unit being started, make certain that engine is at idle speed before disconnecting jumper cables.

SWEEPING

While sweeping close tailgate frequently to ensure tailgate does not creep open.

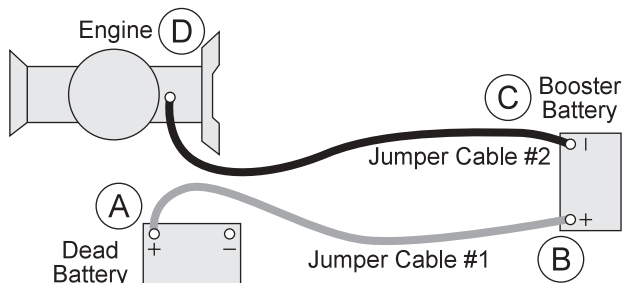

SERVICE CHART KOHLER COMMAND 25 HP



Before servicing or making adjustments to the machine, stop engine, set park break, block wheels and remove key from ignition.



Follow all procedures and **ONLY** use parts prescribed by the manufacturer. Read the engine manual before maintenance.

	Daily	As Required	100 Hours	200 Hours	250 Hours	300 Hours	400 Hours	Every 500 Hours/Yearly
⌘ Engine Oil w/ Filter 2.1qt. (2 l)	C		R	R		R	R	R
⌘ Engine Oil Filter				R			R	R
Engine for Leaks and Loose Parts	C		C	C		C	C	C
‡ Air Cleaner (Paper Element)		C	C	C		C	C	R
‡ Pre-Cleaner (Every 25 hours)		C	C	C	C	C	C	R
Spark Plugs		R		C			C	R
Idle Speed (1200 RPM)					C			C
‡ Cooling System		C	C	C		C	C	C
Belts and Hoses	C				C			C
* Tire Pressure	C		C	C		C	C	C
Visual Inspection of Tires	C		C	C		C	C	C
Fuel Level	C	C						
Fuel Filter		R						R
Hydraulic Oil	C		C	C		C	C	R
†Hydraulic Oil Filter					R			R
Hydraulic System for Leaks and Loose Parts	C		C	C		C	C	C
Battery Electrolyte Level			C	C		C	C	C
Clean Battery Terminals					C			C
§ Torque Lug Nuts				C			C	C
Lubricate			C	C		C	C	C
Lubricate Splines on Hydrostatic Pump	Every 500 hours							

C=Check or Clean at specified intervals

R=Replace at specified intervals

* Tire pressure: 20 psi (1.4 bar) Front and Castor. 18 psi (1.3 bar) Rear.

† Replace hydraulic filter after the first 20, 100, and every 250 there after.

§ Torque tire nuts after the first 10 hours and every 200 hours there after (64 to 74 ft/lb (87-100 Nm))

⌘ Change Oil and Filter after first 5 hours.

‡ Clean more often under dusty conditions or when airborne debris is present , replace air cleaner parts, if very dirty.

The suggested maintenance checklist is not offered as a replacement for the manufacturer's engine manual but as a supplement. You must adhere to the guidelines established by the manufacturer for warranty coverage. In adverse conditions such as dirt, mud or extreme temperatures, maintenance should be more frequent.



SERVICE CHART KUBOTA DIESEL 18.8 HP



Before servicing or making adjustments to the machine, stop engine, set park break, block wheels and remove key from ignition.



Follow all procedures and **ONLY** use parts prescribed by the manufacturer. Read the engine manual before maintenance.

	Daily	As Required	100 Hours	200 Hours	250 Hours	300 Hours	400 Hours	Every 500 Hours/Yearly
⌘ Engine Oil w/ Filter 4qt. (3.8 l)	C		R	R		R	R	R
⌘ Engine Oil Filter				R			R	R
Engine for Leaks and Loose Parts	C		C	C		C	C	C
‡ Air Cleaner (Paper Element)	C	C	C	C		C	C	R
Idle Speed (1200 RPM)					C			C
‡ Cooling System		C	C	C		C	C	C
Belts and Hoses	C				C			C
* Tire Pressure	C		C	C		C	C	C
Visual Inspection of Tires	C		C	C		C	C	C
Fuel Level	C	C						
Fuel Filter		R	C	C		C	C	R
Hydraulic Oil	C		C	C		C	C	R
† Hydraulic Oil Filter					R			R
Hydraulic System for Leaks and Loose Parts	C		C	C		C	C	C
Battery Electrolyte Level			C	C		C	C	C
Clean Battery Terminals					C			C
§ Torque Lug Nuts				C			C	C
Lubricate			C	C		C	C	C

C=Check or Clean at specified intervals

R=Replace at specified intervals

* Tire pressure: 20 psi (1.4 bar) Front and Castor. 18 psi (1.3 bar) Rear.

† Replace hydraulic filter after the first 20, 100, and every 250 there after.

§ Torque tire nuts after the first 10 hours and every 200 hours there after (64 to 74 ft/lb (87-100 Nm))

⌘ Change Oil and Filter after first 50 hours.

‡ Clean more often under dusty conditions or when airborne debris is present , replace air cleaner parts, if very dirty.

The suggested maintenance checklist is not offered as a replacement for the manufacturer's engine manual but as a supplement. You must adhere to the guidelines established by the manufacturer for warranty coverage. In adverse conditions such as dirt, mud or extreme temperatures, maintenance should be more frequent.

END USER'S SERVICE CHART

	Daily	As Required	100 Hours	200 Hours	250 Hours	300 Hours	400 Hours	Every 500 Hours/Yearly
Engine Oil w/ Filter								
Engine Oil Filter								
Engine for Leaks and Loose Parts								
Air Cleaner (Paper Element)								
Pre-Cleaner (Every 25 hours)								
Spark Plugs								
Idle Speed								
Cooling System								
Belts and Hoses								
Tire Pressure								
Visual Inspection of Tires								
Fuel Level								
Fuel Filter								
Hydraulic Oil								
Hydraulic Oil Filter								
Hydraulic System for Leaks and Loose Parts								
Battery Electrolyte Level								
Clean Battery Terminals								
Torque Lug Nuts								
Lubricate								
Lubricate Splines on Gas Hydrostatic Pump Every 500 Hours								



ADJUSTMENTS

PARK BRAKE ADJUSTMENT

By turning knob on end of park brake lever you can tighten or loosen brake a small amount. To tighten turn the knob clockwise. To loosen turn counter clockwise. If this is not enough turn clevis on brake cable to adjust length of cable.

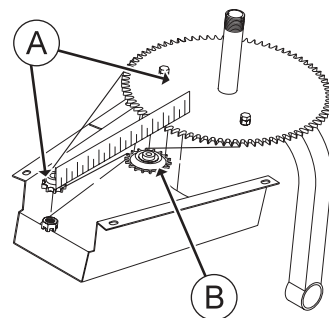

STEERING CHAIN ADJUSTMENT

Steering Sprockets (A) should be level with each other. Check with straight edge. Make any adjustments. Slide Idler Pulley (B) so that it is snug onto the chain. Tighten all nuts and bolts in place.

WHEEL 'CREEP' ADJUSTMENT

'Creep' is when engine is running and hydrostatic transmission is in neutral, but due to inadequate alignment, wheels still move. Do the following procedures to stop this motion.

1. Lift up and support the unit so rear wheels are off the ground and can turn freely.
2. On the side of hydrostatic transmission is the Shift Arm (C) . In the 'V' shaped notch of shift arm rests Idler Pulley (D). This Pulley is mounted on an Idler Arm (E).
3. Loosen bolt and nut holding Pulley to Idler Arm. Leave finger tight.
4. With engine running, slide the Pulley in Idler Arm slot until it centers on Shift Arm on hydrostatic and wheel 'creep' stops.
5. Tighten all fasteners and test by using foot pedal linkage to see that the 'creep' is removed.
6. Turn the engine off and lower the machine.

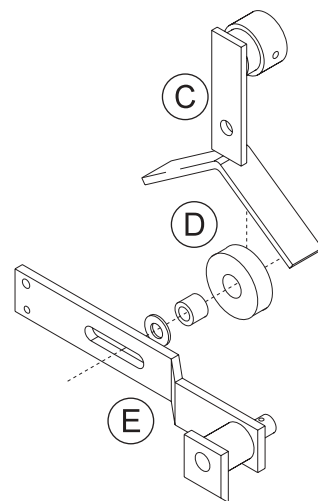

STORAGE

When storing, remove the key from the key switch to avoid unauthorized persons from operating machine.

1. Before storing clean machine thoroughly.
2. Check bolts and nuts, tighten as necessary.
3. Make all repairs that are needed and remove any debris.
4. Remove the battery, adjust the electrolyte level and recharge it. Store the battery in a dry, dark place.
5. Store in a clean and dry area, but NOT near a stove, furnace or water heater which uses a pilot light or any device that can create a spark.
6. Engines stored over 30 days need to be protected or drained of fuel to prevent gum from forming in a fuel system or on essential carburetor parts. Check the engine manual and follow the instructions for the storage of the engine.

DIESEL WIRING DIAGRAM

Color Code Chart

Bl	Blue
Br	Brown
Y	Yellow
Grn	Green
O	Orange
R	Red
B	Black
P	Purple
W	White

Diagrams

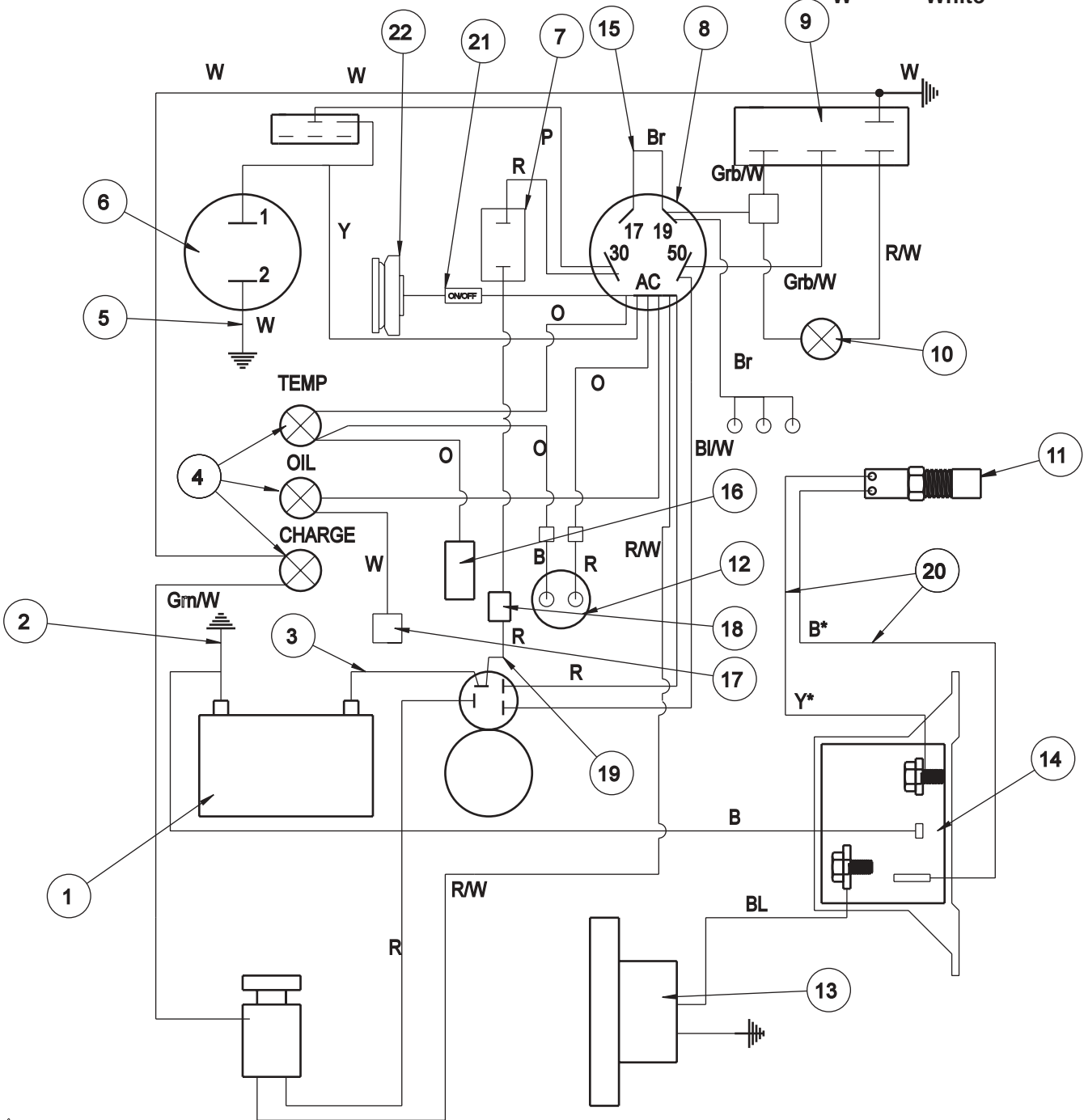

DIESEL WIRING PARTSLIST

REF#	PART#	DESCRIPTION	QUANTITY
1	22-073	Battery	1
2	22-054	Black Battery Cable	1
3	75-518	Red Battery Cable	1
	8892-40	Hose Wrap 1/4 x 40	1
4	50-359	Warning Indicator Lights	3
5	77-209	Hour Meter to Ground Wire	1
6	12-017	Hour Meter	1
7	34-146	Panel Mount Circuit Breaker	1
	34-145	Circuit Breaker Boot	1
8	17-068	Key Switch	1
	17-079	Key Set	1
9	77-223	Glow Lamp Timer	1
10	77-211	Glow Plug Indicator	1
11*	77-208-05	Air Pack Switch (part of engine)	1
12	77-207	Buzzer	1
13	77-201	Electric Fan	1
14*	77-233	Bosch Power Relay	1
15	77-226	Wire 17 to 19 Ignition Switch	1
16	77-208-01	Temperature Sender (part of engine)	1
17		Oil Sender (part of engine)	1
18	8975	30Amp Circuit Breaker	1
	8977	Circuit Breaker Boot	1
19	48-144	Circuit Breaker Wire	1
20*	77-203	Thermostat Wire Harness	1
21	15-314	Toggle Switch	1
	15-472	Boot	1
22	76-337	Electric Clutch	1
	77-245	Clutch Wire Harness	1
	77-205	Wire Harness (contains all wires except # 4 & 15)	1
*	77-235	Thermostat Kit	

GAS WIRING DIAGRAM

Color Code Chart	
Bl	Blue
Br	Brown
Y	Yellow
Grn	Green
O	Orange
R	Red
B	Black
P	Purple
W	White

Diagrams

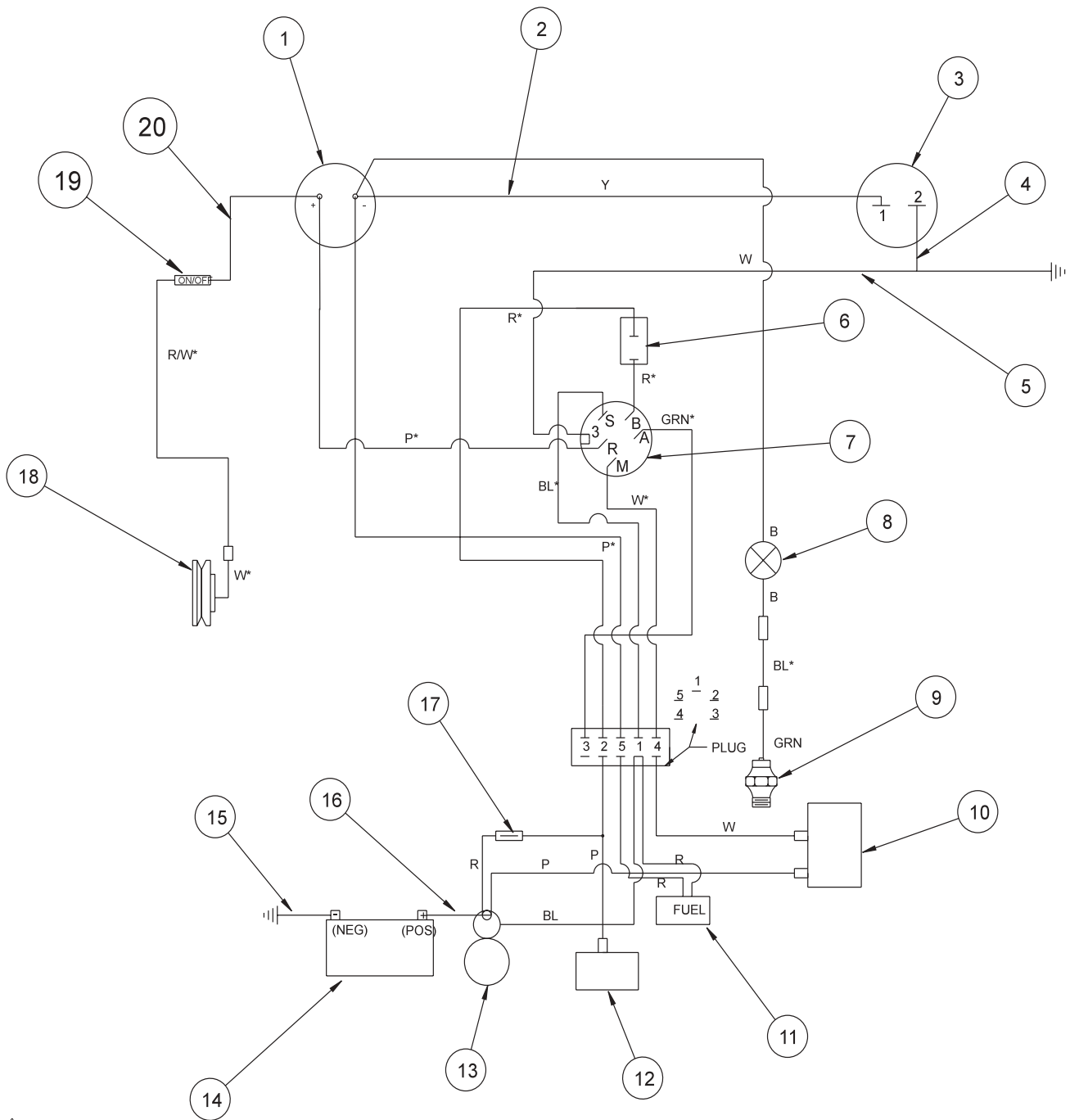

GAS WIRING PARTSLIST

REF#	PART#	DESCRIPTION	QUANTITY
1	22-003	Ammeter	1
2	76-269	Power Wire to Hour Meter	1
3	12-017	Hour Meter	1
4	76-259	Ground Wire for Hour Meter	1
5	76-260	Ground Wire for Ignition Switch	1
6	34-146	Panel Mount Circuit Breaker	1
	34-145	Circuit Breaker Boot	1
7	13-288	Key Switch with Hardware (Kohler #25 099 04)	1
8	50-359	Warning Indicator Light	1
9		Oil Sender (Part of Engine)	
10		Ignition Module (Part of Engine)	
11		Fuel Shut-Off Solenoid (Part of Engine)	
12		Rectifier (Part of Engine)	
13		Starter (Part of Engine)	
14	22-073	Battery	1
	48-166	Battery Holddown	1
15	22-054	Black Battery Cable	1
16	75-518	Red Battery Cable	1
	8892-40	Hose Wrap 1/4 x 40	1
17		Wire With Fuse (Part of Engine)	
		Fuse AGC 30	
18	76-337	Electric Clutch	1
19	15-314	Toggle Switch	1
	15-472	Switch Boot	1
20	76-342	Wire Switch to Ammeter	1
*	76-258	Wire Harness (Includes all wire color with *)	1

HYDRAULIC DIAGRAM

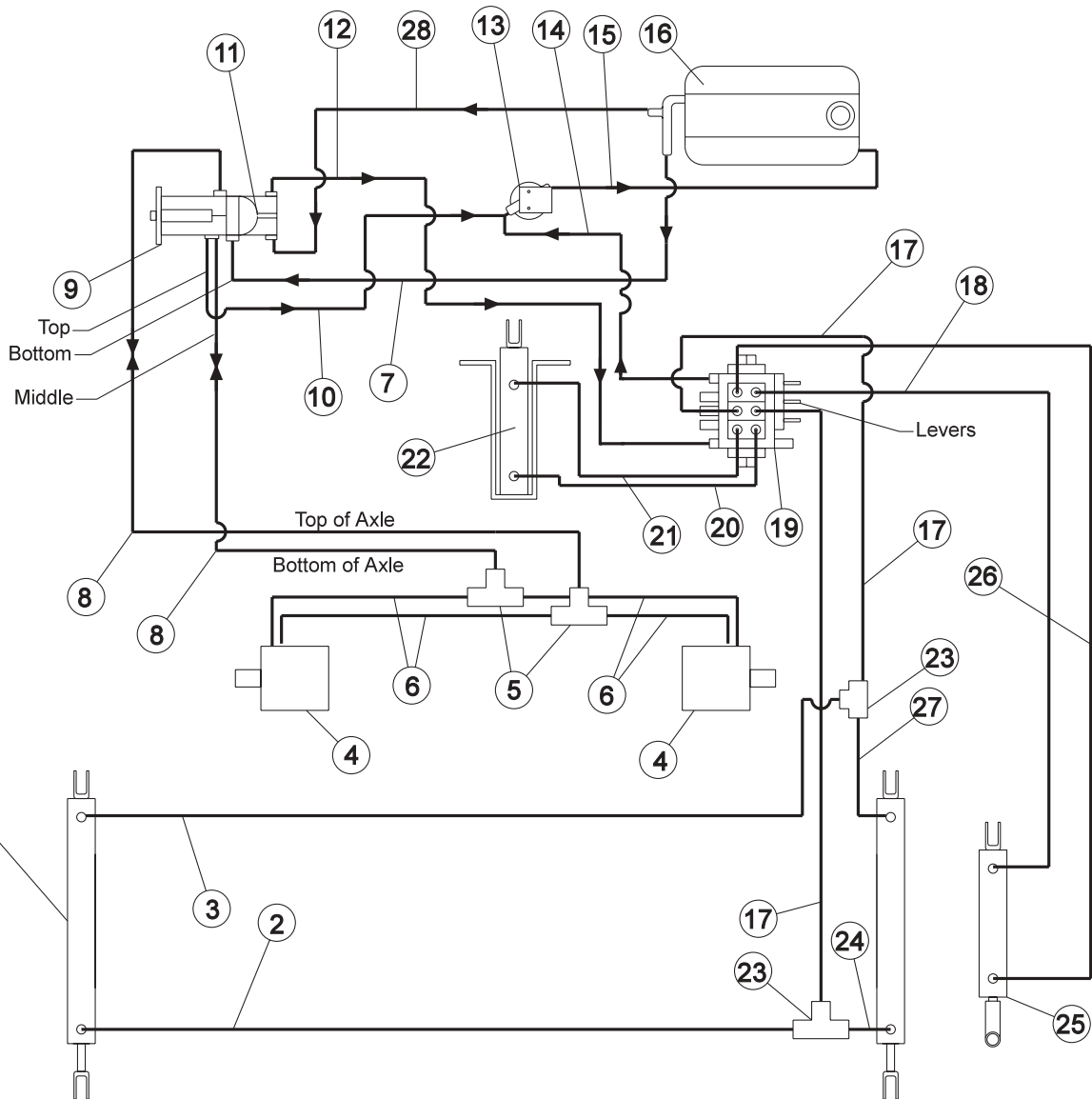

76-023 Hydraulic Valve
Relief Valve set at 2000 psi (137.93 bar)

76-100 Hydrostatic Pump
Displacement Variable to 1.44 in³/R (23.6 cm³/R)
22.44 gpm (84.94 lpm) at 3600 rpm
Max Operating Speed 3600 rpm
Rated Pressure 3000 psi (206.8 bar)
Max Pressure 5000 psi (344.7 bar)
Max Inlet Vacuum 6 in Hg (.203 bar)
Max Inlet Temperature 225°F (107°C)
Max Allowable Case Pressure 25 psi (1.72 bar)

76-197 Gear Pump
Displacement .40 in³/R (6.6 cm³/R) 6.23 gpm (25.39 lpm)

HYDRAULIC DIAGRAM PARTS LIST

REF#	PART#	DESCRIPTION	QUANTITY
1	76-242	Hydraulic Cylinder	2
2	76-115	Hydraulic Hose	1
3	76-114	Hydraulic Hose	1
4	76-238	Wheel Motor	2
5	34-057	Tee	2
6	76-208	Hydraulic Hose	4
7	8832-21.5	Suction Hose	1
	18-040	Hose Clamp	2
8	76-209	Hydraulic Hose	2
	8895-50	1" Hose Wrap (Top of Axle)	1
	8895-48	1" Hose Wrap (Bottom of Axle)	1
	18-222	Hose Clamp	4
9	77-239	Hydrostatic Pump	1
10	76-207	Hydraulic Hose	1
	8895-21	1" Hose Wrap	1
	18-222	Hose Clamp	2
11	76-197	Gear Pump	1
12	76-104	Hydraulic Hose	1
	8895-29	1" Hose Wrap	1
	18-222	Hose Clamp	2
13	23-006	Oil Filter	1
	23-031	Filter Element (Replacement Only)	1
14	76-105	Hydraulic Hose	1
	8895-19	1" Hose Wrap	1
	18-222	Hose Clamp	2
15	8917-38	Suction Hose $\frac{5}{8}$ ID	1
	18-040	Hose Clamp	2
16	48-135	Oil Tank	1
17	76-202	Hydraulic Hose	2
	8892-26	$\frac{1}{4}$ " Hose Wrap	2
18	76-204	Hydraulic Hose	1
	8892-26	$\frac{1}{4}$ " Hose Wrap	1
19	76-023	Hydraulic Valve	1
20	76-205	Hydraulic Hose	1
	8892-31	$\frac{1}{4}$ " Hose Wrap	1
21	76-206	Hydraulic Hose	1
	8895-27	1" Hose Wrap	1.
	18-222	Hose Clamp	2
22	75-634	Hydraulic Cylinder	1
23	18-173	Tee $\frac{3}{8}$ Junction Union	2
24	76-117	Hydraulic Hose	1
25	50-456	Hydraulic Cylinder	1
26	76-203	Hydraulic Hose	1
	8892-26	$\frac{1}{4}$ " Hose Wrap	1
27	76-116	Hydraulic Hose	1
28	8832-19.5	Suction Hose	1
	18-040	Hose Clamp	2
	8895-22	1" Hose Wrap (Gas Unit Only)	1
	8895-20	1" Hose Clamp (Diesel Unit Only)	1
	18-222	Hose Clamp	2

BODY AND FRAME DRAWING

When Filtration System is to be installed, Ref. 9 Hopper Screen Cover is to be removed.
When Filters are used, 76-262 Tailgate Screen is replaced by 76-249 Tailgate Filter Screen. 76-261 Hopper Screen is replaced by 76-248 Hopper Filter Screen.

Parts

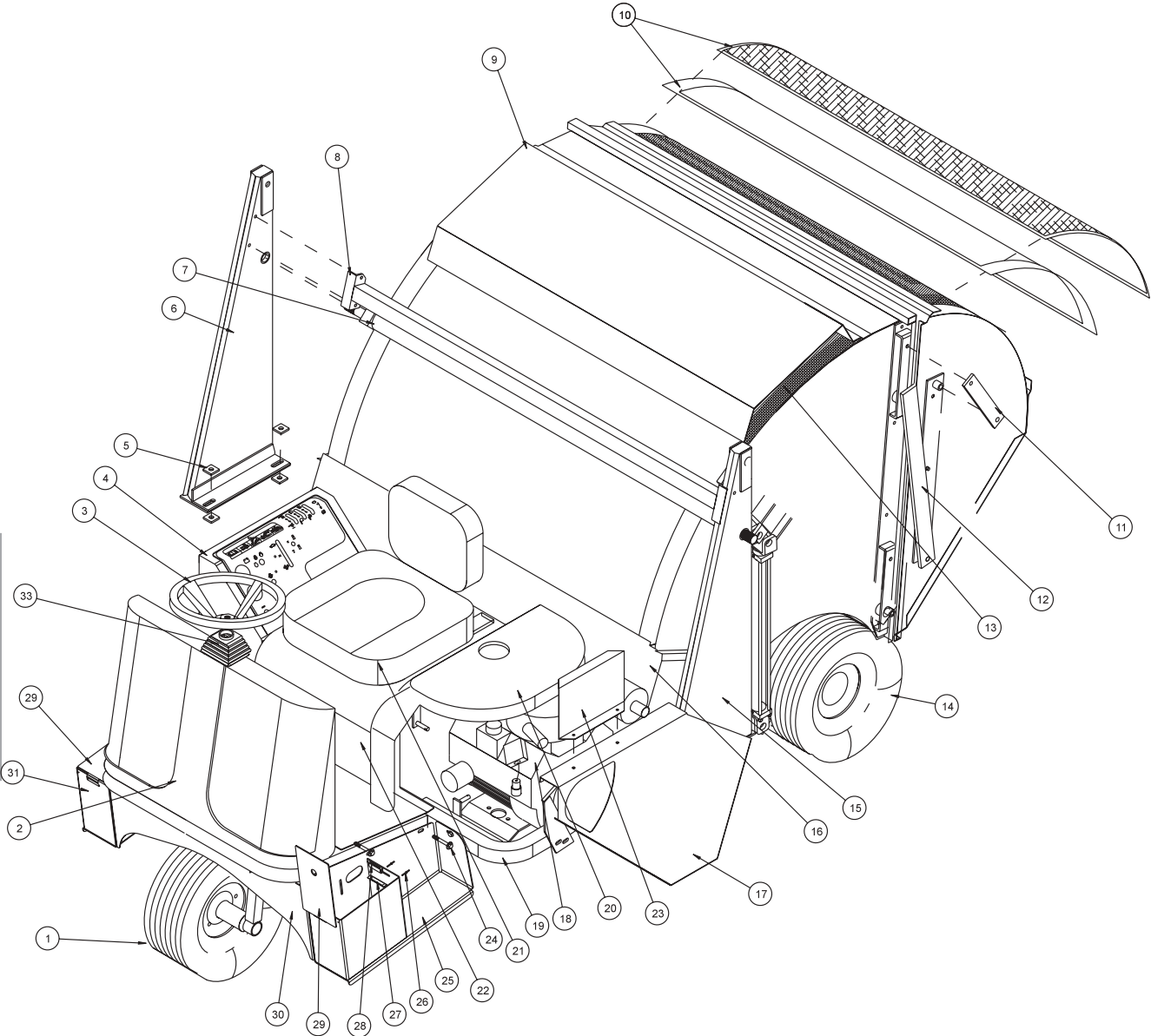

BODY AND FRAME PARTS LIST

REF#	PART#	DESCRIPTION	QUANTITY
1§	60-130	Tire and Wheel	1
	60-130-01	Tire 18 x 9.50 - 8	1
	60-130-02	Wheel	1
	8839	Windshield Washer Fluid or Equivalent	28 pints
2	76-264	Nose Cone	1
	76-354	2½ # ABC Dry Chemical Fire Extinguisher	1
NS	76-372	Inclinometer	1
NS	76-373	Inclinometer Bracket	1
3	13-718	Steering Wheel	1
4	76-265	Gas Console	1
	77-193	Diesel Console	1
	76-219	Console Support	1
5	76-151	Washer	8
6	75-561	Right Tower	1
7	75-570	Arm Pivot Tube	1
8	76-211	Cross Bar	1
9	76-359	Hopper Screen Cover	1
	HB-516-18-100	Bolt 5/16 -18 x 1	6
	HNFL-516-18	Flange Whiz Lock Nut 5/16 - 18	6
10*	76-249	Tailgate Filter Screen	1
	76-247	Tailgate Filter Pack	1
11	75-564	Tailgate Hinge	2
12	75-568	Right Tailgate Dump Arm	1
13*	76-248	Hopper Filter Screen	1
	76-246	Hopper Filter Pack	1
14	16-225	Tire and Wheel	2
	16-225-01	Tire 24 x 13 -12NHS	2
	16-225-02	Wheel	2
15	75-629	Left Tower	1
16	76-235	Grass Chute Frame	1
	8947-60	Trim Seal	2
	8842-14	Foam Tape	2
17	76-341	Side Belt Guard	1
	48-047	Side Blet Guard Tab (Diesel only)	1
18	76-267	Kohler Command 25 hp Gas Engine	1
	77-208	D-722 Diesel Kubota Engine	1
19	76-290	Main Frame (Gas Only)	1
	77-244	Main Frame (Diesel Only)	1
	76-231	Step (right side)	1
20	76-266	Gas Engine Cover	1
	77-194	Diesel Engine Cover	1
21	14-270	Seat	1
22	76-289	Seat Assembly	1
23	77-180	Belt Guard (diesel only)	1
24	HB-38-16-300	Bolt 3/8 -16 x 3	6
	HW-38	Washer 3/8	6
	HNTL-38-16	Lock Nut 3/8- 16	6
25	48-160	Right Step	1
	8803-10	Black Trim 10"	1
26	HRS-18-050	Rivet 1/8 x 1/2	4
	HW-6	Washer #6	4
27	48-164	Magnet	2
28	48-165	Magnet Bracket	2
29	48-159	Battery Box Cover	2
30	48-158	Front Cover	1
31	48-161	Left Step	1
§	Front tire and wheel fluid filled to 50 lbs. total.		
*	Optional 76-271	Filtration System (includes Ref. 10 and 13)	1

76-375 ROLLOVER PROTECTION DRAWING

Parts

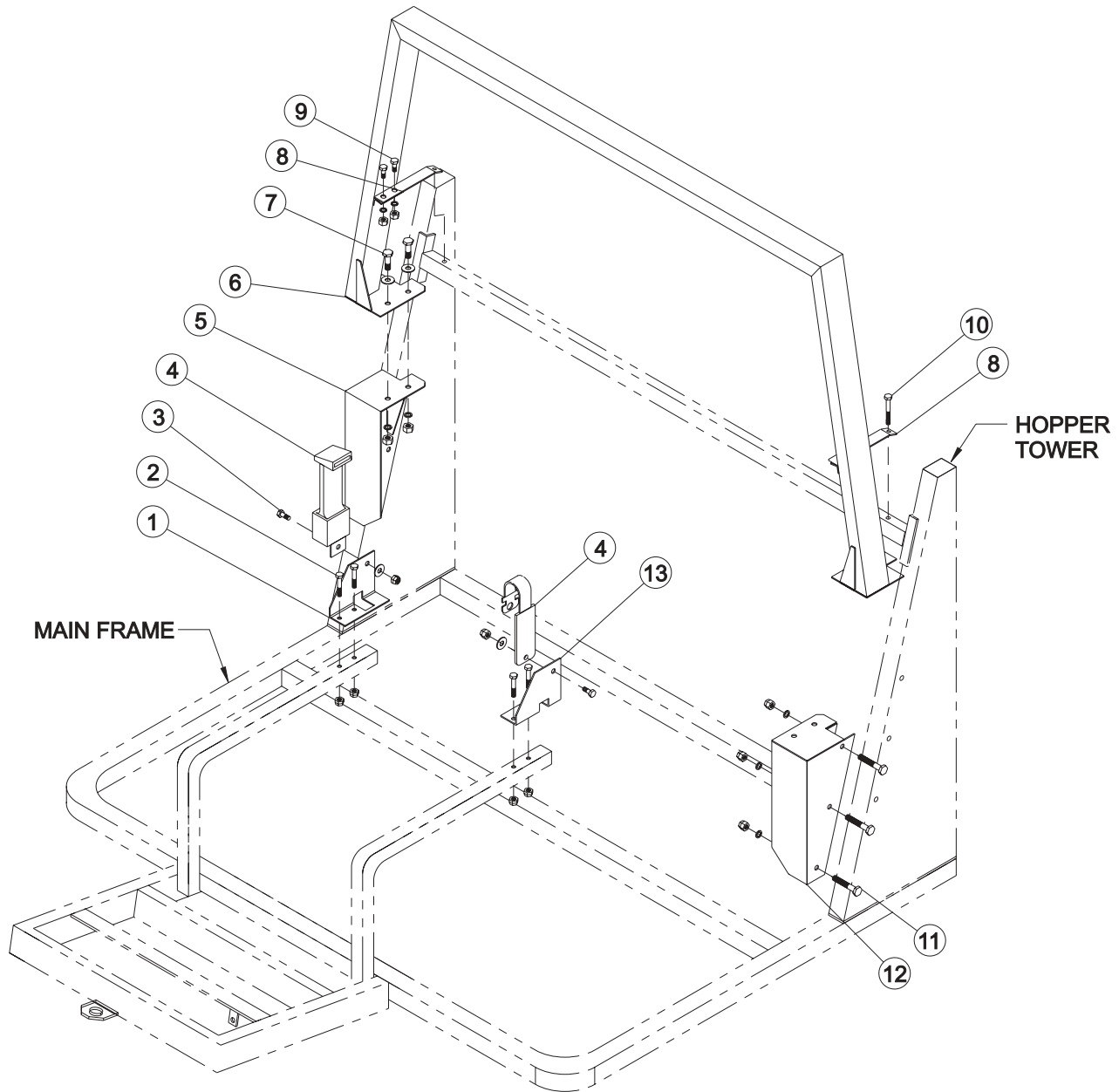

76-375 ROLLOVER PROTECTION PARTS LIST

REF#	PART#	DESCRIPTION	QUANTITY
1	76-377	Right Seat Belt Bracket	1
2	HB-38-16-200	Bolt ³ / ₈ - 16 x 2	4
	HWL-38	Lockwasher ³ / ₈	4
	HN-38-16	Nut ³ / ₈ - 16	4
3	HB-716-14-100	Bolt ⁷ / ₁₆ - 14 x 1	2
	HWL-716	Lockwasher ⁷ / ₁₆	2
	HN-716-14	Nut ⁷ / ₁₆ - 14	2
4	76-198-03	Seat Belt	1
5	76-379	Right Support	1
6	76-381	Roll Bar	1
7	HB-12-13-125	Bolt ¹ / ₂ - 13 x 1 ¹ / ₄	4
	HW-12	Washer ¹ / ₂	4
	HWL-12	Lockwasher ¹ / ₂	4
	HN-12-13	Nut ¹ / ₂ - 13	4
8	76-376	Strap	2
9	HB-38-16-100	Bolt ³ / ₈ - 16 x 1	4
	HWL-38	Lockwasher ³ / ₈	4
	HN-38-16	Nut ³ / ₈ - 16	4
10	HB-38-16-300	Bolt ³ / ₈ - 16 x 3	2
	HWL-38	Lockwasher ³ / ₈	2
	HN-38-16	Nut ³ / ₈ - 16	2
11	HB-12-13-300	Bolt ¹ / ₂ - 13 x 3	6
	HWL-12	Lockwasher ¹ / ₂	6
	HN-12-13	Nut ¹ / ₂ - 13	6
12	76-380	Left Support	1
13	76-378	Left Seat Belt Bracket	1

STEERING DRAW1

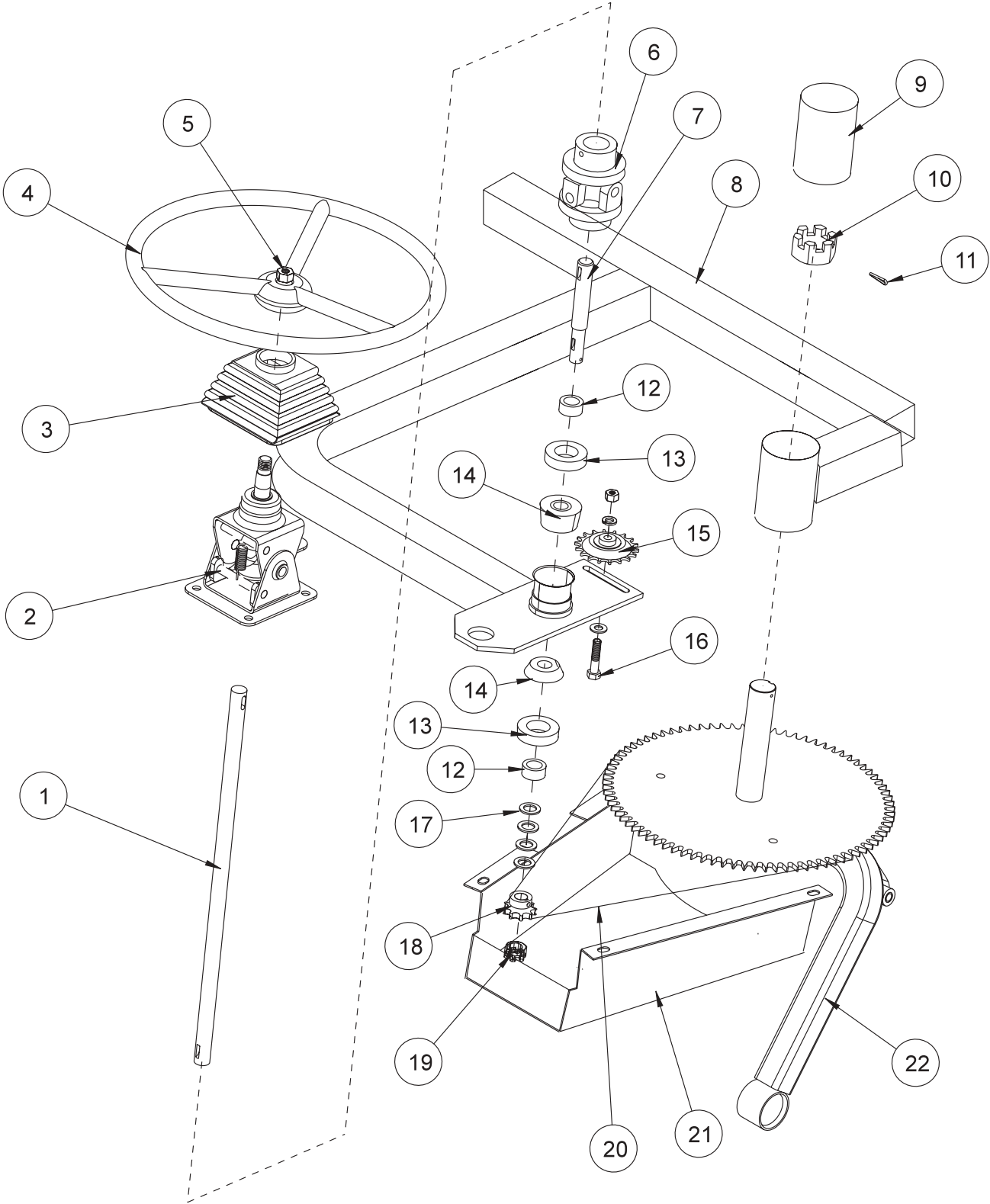

Parts

STEERING PARTS LIST

REF#	PART#	DESCRIPTION	QUANTITY
1	48-186	Steering Shaft	1
	HWK-316-075	Woodruff Key $\frac{3}{16} \times \frac{3}{4}$	1
2	76-362	Tilt Steering Mechanism	1
3	76-364	Tilt Steering Boot	1
4	13-718	Steering Wheel	1
	13-726	Steering Wheel Cap	1
5	HNJ-58-18	Jam Nut $\frac{5}{8}$ - 18	1
6	75-833	Universal Joint	1
	HRP-532-150	Roll Pin $\frac{5}{32} \times 1\frac{1}{2}$	2
	HSSHS-38-16-038	Socket Head Set Screw $\frac{3}{8}$ - 16 x $\frac{3}{8}$	2
7	75-813	Bottom Steering Shaft	1
	HWK-316-075	Woodruff Key $\frac{3}{16} \times \frac{3}{4}$	1
8		Main Frame	
9	76-301	Rubber Cap	1
10	HNAT-114-12	Thick Axle Nut $1\frac{1}{4}$ - 12	1
11	HP-18-150	Cotter Pin $\frac{1}{8} \times 1\frac{1}{2}$	1
12	11-040	Spacer $\frac{3}{4}$	2
13	11-039	Seal	2
14	11-038	Bearing Cup and Cone	1
15	76-156	Idler Sprocket	1
16	HB-38-16-175	Bolt $\frac{3}{8}$ - 16 x $1\frac{3}{4}$	1
	HW-38	Washer $\frac{3}{8}$	1
	HWL-38	Lockwasher $\frac{3}{8}$	1
	HN-38-16	Nut $\frac{3}{8}$ - 16	1
17	HMB-58-14	Machine Bushing $\frac{5}{8}$ - 14	as Req'd
18	76-153	Sprocket	1
	HWK-316-063	Woodruff Key $\frac{3}{16} - \frac{5}{8}$	1
19	HNA-58-18	Axle Nut $\frac{5}{8}$ - 18	1
	HP-18-150	Cotter Pin $\frac{1}{8} \times 1\frac{1}{2}$	1
20	8827-59	Roller Chain	1
	18-032	Master Link #40	1
21	75-803	Chain Guard	1
	HSTP-516-18-100	Phillips Truss Machine Screw $\frac{5}{16}$ - 18 x 1	4
	HW-516	Washer $\frac{5}{16}$	4
	HWL-516	Lockwasher $\frac{5}{16}$	4
	HN-516-18	Nut $\frac{5}{16}$ - 18	4
22	76-155	Front Fork	1

FRONT FORK DRAWING

Parts

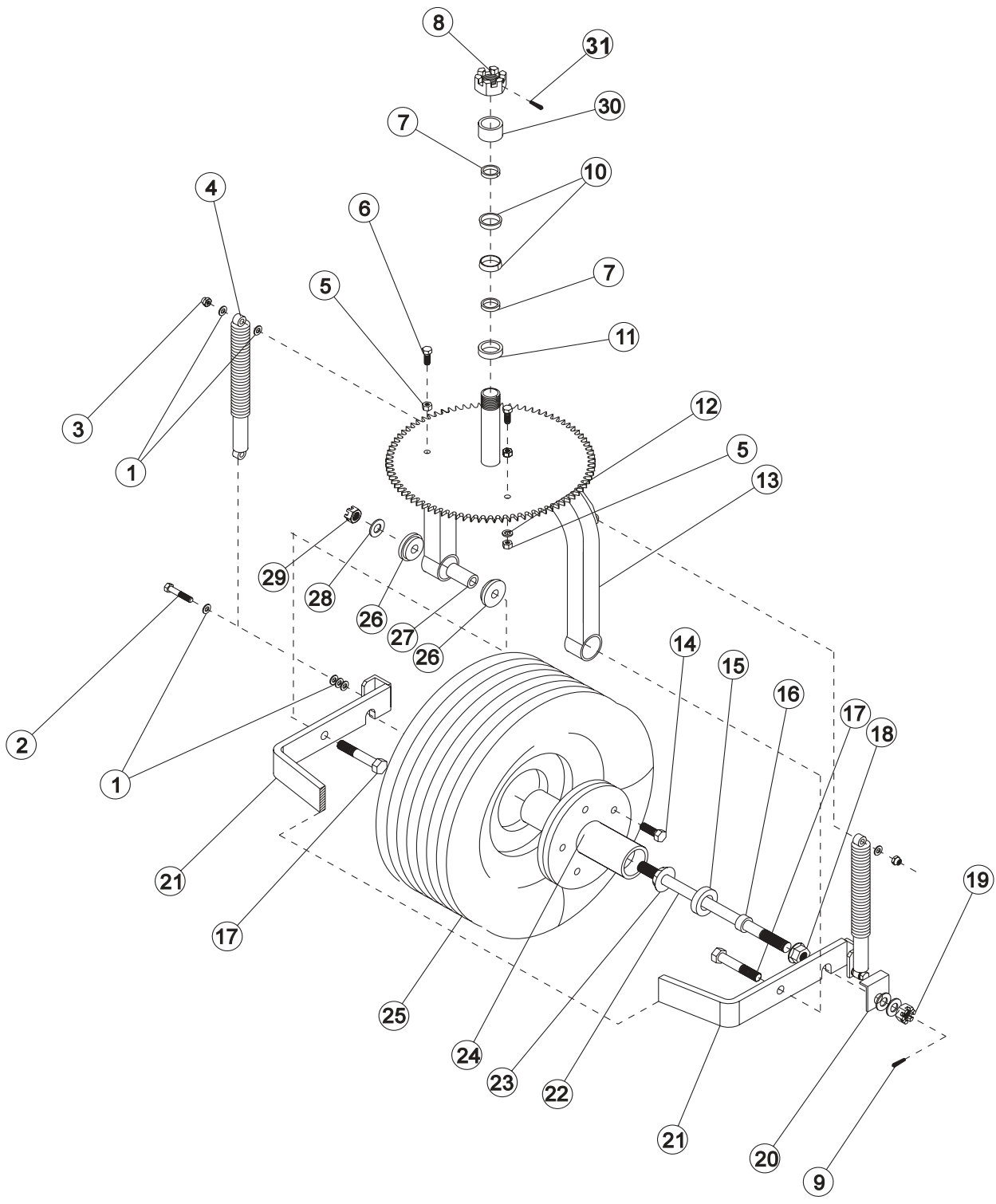

FRONT FORK PARTSLIST

REF#	PART#	DESCRIPTION	QUANTITY
1	HW-38	Washer $\frac{3}{8}$ (as Req'd)	14
2	HB-38-16-200	Bolt $\frac{3}{8}$ - 16 x 2	2
	HNTL-38-16	Locknut $\frac{3}{8}$ - 16	2
3	HB-38-16-250	Bolt $\frac{3}{8}$ - 16 x 2 $\frac{1}{2}$	2
	HNTL-38-16	Locknut $\frac{3}{8}$ - 16	2
4	75-715	Shock Absorber	2
	75-715-01	Bushing with Insert	2 per Shock
5	HN-38-16	Nut $\frac{3}{8}$ - 16	4
6	HB-38-16-100	Bolt $\frac{3}{8}$ - 16 x 1	2
7	20-142	Grease Seal 1 $\frac{1}{4}$	2
8	HNAT-114-12	Thick Axle Nut 1 $\frac{1}{4}$ - 12	1
9	HP-18-150	Cotter Pin $\frac{1}{8}$ x 1 $\frac{1}{2}$	2
10	20-143	Bearing Cup and Cone 1 $\frac{1}{4}$ ID	2
11	20-141	Spacer 1 $\frac{5}{8}$ OD x 1 $\frac{1}{4}$ ID x $\frac{7}{16}$	1
12	HWL-38	Lockwasher $\frac{3}{8}$	2
13	76-155	Front Fork	1
14*	27-022-02	Bolt Stud $\frac{1}{2}$ - 20 x 1 $\frac{1}{2}$ (just bolt; comes with Ref 24)	5
	HNL-12-20	Lug Nut $\frac{1}{2}$ - 20	5
15*	11-039	Grease Seal 1 $\frac{1}{8}$ ID (comes with Ref 24)	2
16	11-040	Spacer 1 $\frac{1}{8}$ OD x $\frac{3}{4}$ ID x $\frac{17}{32}$	2
17	HB-58-18-350	Bolt $\frac{5}{8}$ - 18 x 3 $\frac{1}{2}$	2
18	HNJ-34-16	Jam Nut $\frac{3}{4}$ - 16	2
19	HNA-34-16	Axle Nut $\frac{3}{4}$ - 16	2
	HMB-34-10	Machine Bushing $\frac{3}{4}$ x 10GA	2
	HMB-34-14	Machine Bushing $\frac{3}{4}$ x 14GA	2
20	60-511	Axle Lock	2
21	60-510	U-Bracket	1
22	60-407	Front Axle	1
23*	11-038	Bearing Cup and Cone $\frac{3}{4}$ ID (comes with Ref 24)	2
24	11-010	Wheel Hub (includes * items)	1
25	60-130	Tire & Wheel	1
	60-130-01	Tire 18 x 9.5 - 8 6 Ply	1
	60-130-02	Wheel	1
	8839	Windshield Washer Fluid or Equivalent	28 pints
26	60-128	Rubber Bushing	4
27	60-406	Spacer 1 OD x $\frac{5}{8}$ ID x 2	2
28	HW-58	Washer $\frac{5}{8}$	2
29	HNTL-58-18	Lock Nut $\frac{5}{8}$ - 18	2
30	76-158	Spacer Seal	1
31	HP-18-200	Cotter Pin $\frac{1}{8}$ x 2	1

* Front tire and wheel fluid filled to 50 lbs. total.

GAS LINKAGE DRAWING

Parts

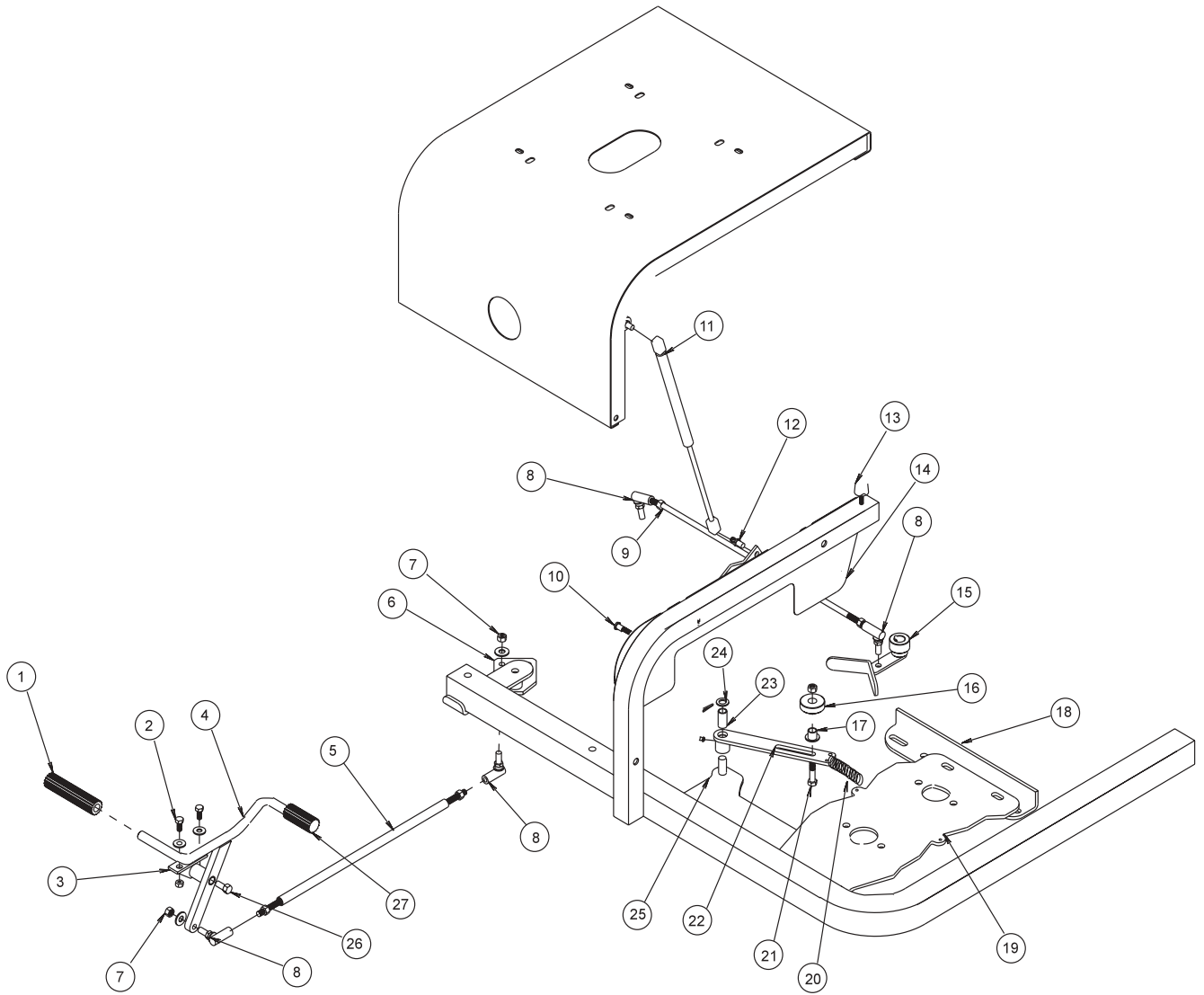

GAS LINKAGE PARTS LIST

REF#	PART#	DESCRIPTION	QUANTITY
1	76-299	Pedal Pad Long	1
2	HB-516-18-075	Bolt $\frac{5}{16}$ - 18 x $\frac{3}{4}$	2
	HW-516	Washer $\frac{5}{16}$	2
	HNTL-516-18	Lock Nut $\frac{5}{16}$ - 18	2
3	76-296	Pedal Mount	1
	18-234	Oilite Bushing	2
	HG-14-28-180	Grease Fitting $\frac{1}{4}$ - 28 x 180°	1
4	48-059	Foot Pedal	1
	18-234	Oilite Bushing	1
5	76-282	Foot Pedal Rod	1
	HN-38-24	Nut $\frac{3}{8}$ - 24	2
6	75-791	Shift Relay	1
	10-007	Bushing	1
7	HN-38-24	Nut $\frac{3}{8}$ - 24	4
	HWL-38	Lockwasher $\frac{3}{8}$	4
8	21-173	Ball Joint $\frac{3}{8}$ - 24	4
9	76-284	Rear Linkage Rod	1
	HN-38-24	Nut $\frac{3}{8}$ - 24	2
10	HSDPS-14-075	Stainless Steel Pan Head Drill Screw $\frac{1}{4}$ x $\frac{3}{4}$	1
11	13-569	Gas Spring 60#	1
12	26-034	Ball Stud	2
13	15-013	Rubber Bumper	2
	HWL-14	Lockwasher $\frac{1}{4}$	2
	HN-14-20	Nut $\frac{1}{4}$ -20	2
14	76-351	Manifold Guard	1
15	77-241	Shift Arm	1
	HSSHS-14-28-031	Set Screw $\frac{1}{4}$ - 28 x $\frac{5}{16}$ (comes with 77-241)	1
16	14-266	Ball Bearing $\frac{5}{8}$ ID x $1\frac{3}{4}$ OD	1
17	76-275	Spacer	1
18		Mainframe	1
19	76-369	Motor Mount	1
20	48-109	Spring	1
21	HB-38-16-200	Bolt $\frac{3}{8}$ - 16 x 2	1
	HW-38	Washer $\frac{3}{8}$	2
	HNTL-38-16	Lock Nut $\frac{3}{8}$ - 16	1
22	76-370	Idler Arm	1
23	10-007	Bushing (part of 76-370)	1
	HG-14-28-180	Grease Fitting $\frac{1}{4}$ - 28 x 180°	1
24	HP-18-075	Cotter Pin $\frac{1}{8}$ x $\frac{3}{4}$	1
	HMB-12-14	Machine Bushing $\frac{1}{2}$ x 14GA	2
25	76-368	Linkage Plate	1
26	HB-12-13-275	Bolt $\frac{1}{2}$ - 13 x $2\frac{3}{4}$	1
	HNTL-12-13	Lock Nut $\frac{1}{2}$ - 13	1
27	76-332	Pedal Pad Short	1

DIESEL LINKAGE DRAWING

Parts

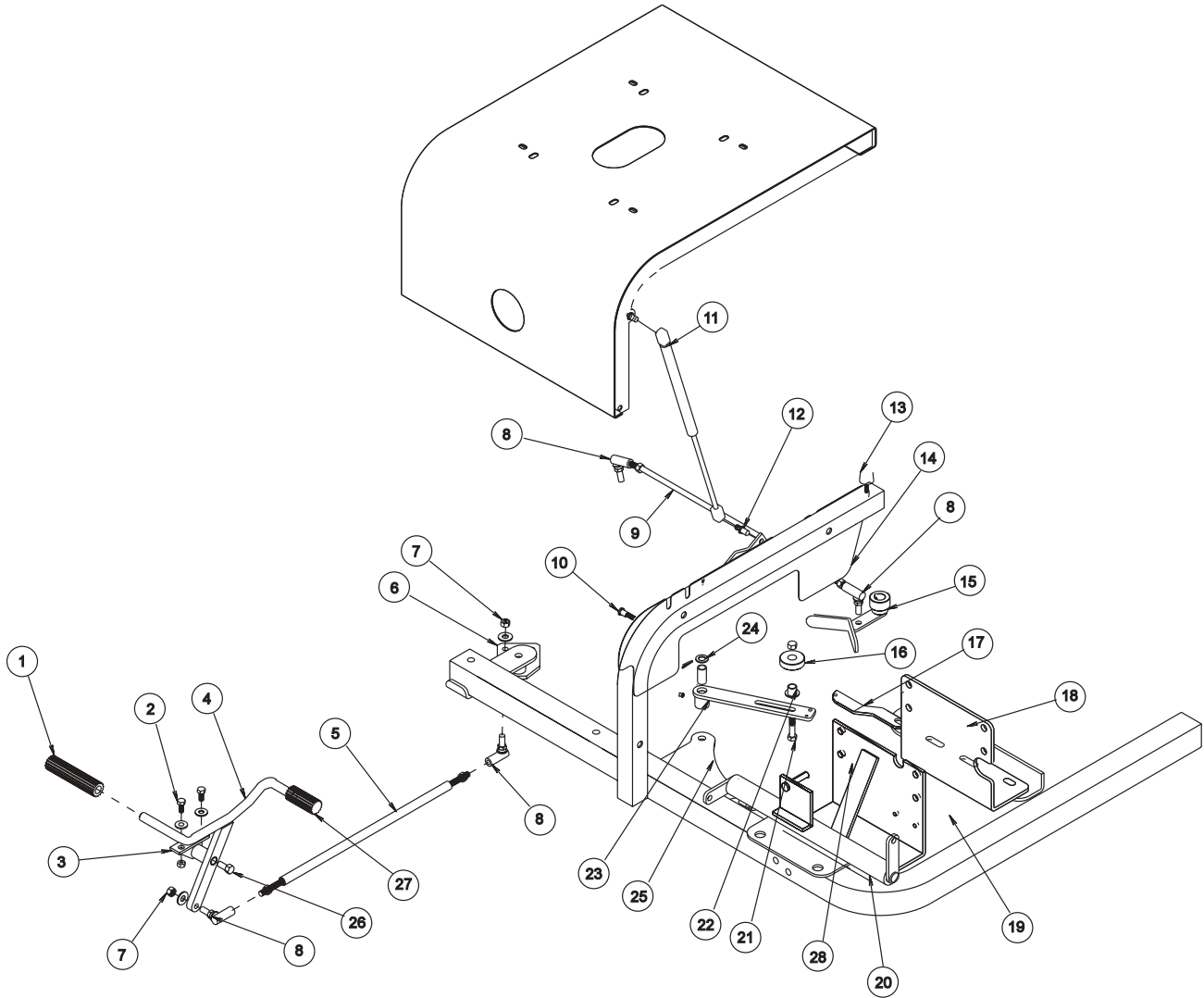

DIESEL LINKAGE PARTS LIST

REF#	PART#	DESCRIPTION	QUANTITY
1	76-299	Pedal Pad Long	1
2	HB-516-18-075	Bolt ⁵ / ₁₆ - 18 x ³ / ₄	2
	HW-516	Washer ⁵ / ₁₆	2
	HNTL-516-18	Lock Nut ⁵ / ₁₆ - 18	2
3	76-296	Pedal Mount	1
	18-234	Oilite Bushing	2
	HG-14-28-180	Grease Fitting ¹ / ₄ - 28 x 180°	1
4	48-059	Foot Pedal	1
	18-234	Oilite Bushing	1
5	76-282	Foot Pedal Rod	1
	HN-38-24	Nut ³ / ₈ - 24	2
6	75-791	Shift Relay	1
	10-007	Bushing	1
7	HN-38-24	Nut ³ / ₈ - 24	4
	HWL-38	Lockwasher ³ / ₈	4
8	21-173	Ball Joint ³ / ₈ - 24	4
9	76-284	Rear Linkage Rod	1
	HN-38-24	Nut ³ / ₈ - 24	2
10	HSDPS-14-075	Stainless Steel Pan Head Drill Screw ¹ / ₄ x ³ / ₄	1
11	13-569	Gas Spring 60#	1
12	26-034	Ball Stud	2
13	15-013	Rubber Bumper	2
	HWL-14	Lockwasher ¹ / ₄	2
	HN-14-20	Nut ¹ / ₄ -20	2
14	76-351	Manifold Guard	1
15	77-241	Shift Arm	1
	HSSHS-14-28-031	Set Screw ¹ / ₄ - 28 x ⁵ / ₁₆ (comes with 77-241)	1
16	14-266	Ball Bearing ⁵ / ₈ ID x ¹ / ₄ OD	1
17	76-275	Spacer	1
18		Mainframe	1
19	76-369	Motor Mount	1
20	48-109	Spring	1
21	HB-38-16-200	Bolt ³ / ₈ - 16 x 2	1
	HW-38	Washer ³ / ₈	2
	HNTL-38-16	Lock Nut ³ / ₈ - 16	1
22	76-370	Idler Arm	1
23	10-007	Bushing (part of 76-370)	1
	HG-14-28-180	Grease Fitting ¹ / ₄ - 28 x 180°	1
24	HP-18-075	Cotter Pin ¹ / ₈ x ³ / ₄	1
	HMB-12-14	Machine Bushing ¹ / ₂ x 14GA	2
25	76-371	Linkage Plate	1
26	HB-12-13-275	Bolt ¹ / ₂ - 13 x ² / ₃	1
	HNTL-12-13	Lock Nut ¹ / ₂ - 13	1
27	76-332	Pedal Pad Short	1

GAS CONSOLE DRAWING

Parts

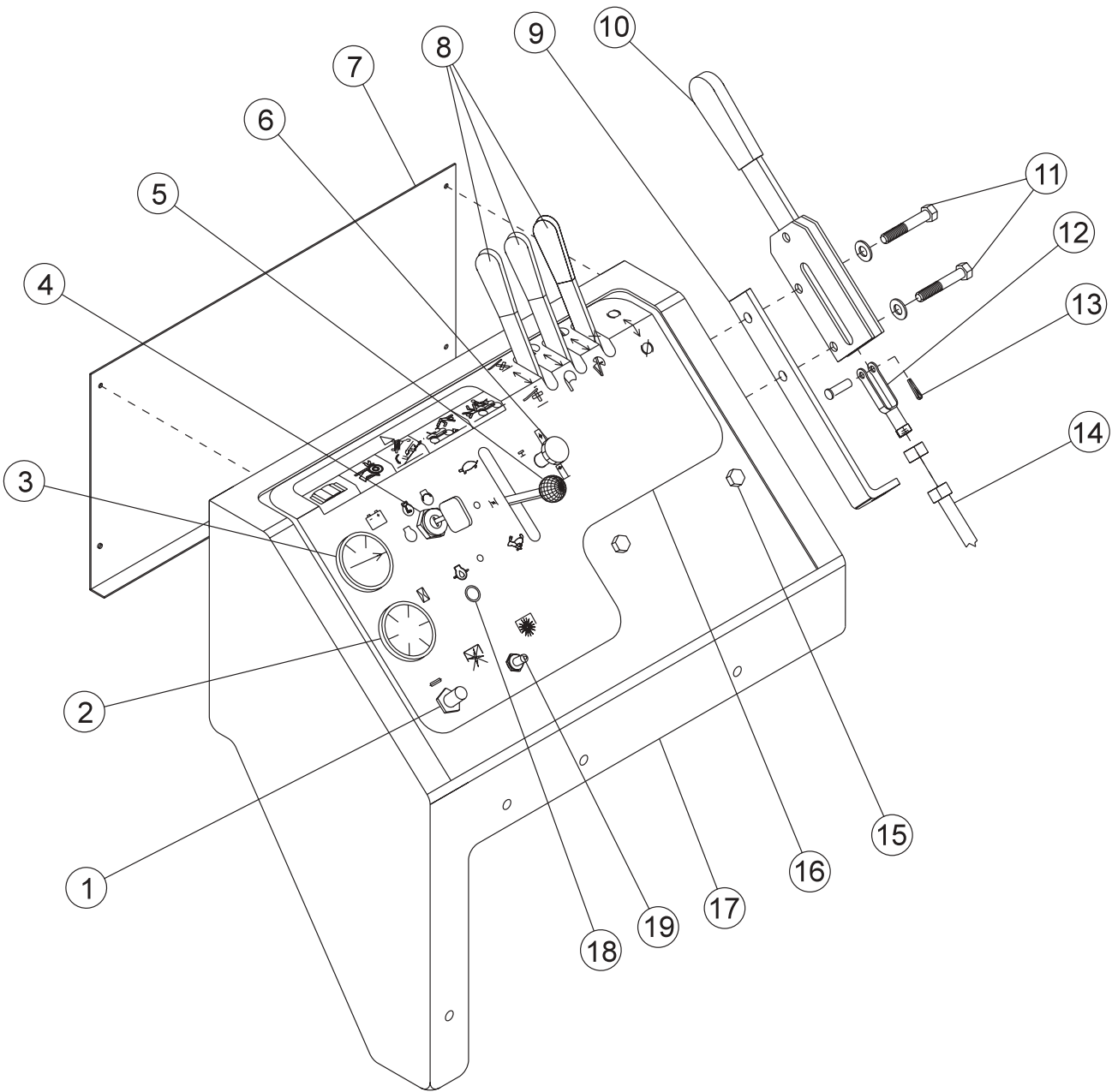

GAS CONSOLE PARTSLIST

REF#	PART#	DESCRIPTION	QUANTITY
1	34-146	Panel Mount Circuit Breaker	1
	34-145	Circuit Breaker Boot	1
2	12-017	Hour Meter	1
3	22-003	Ammeter	1
4	13-288	Key Switch (with hardware Kohler# 25 099 04)	1
	76-310	Key Set	1
5	34-160	Throttle 48"	1
	34-159	Throttle Mounting Bracket	1
	HSM-10-32-063	Machine Screw 10 - 32 x $\frac{5}{8}$	4
	HSM-10-32-100	Machine Screw 10 - 32 x 1	2
	HWL-10	Lockwasher 10	6
	HN-10-32	Nut 10 - 32	6
6	80-020	Choke Cable	1
7	76-214	Side Panel	1
	HSA-8-100	Tapping Screw #8 x 1	4
8	76-309	Valve Handle (with Linkage Kit)	1
	76-023	Hydraulic Valve (3 bank)	1
9	76-224	Park Brake Handle Mount	1
10	60-106	Brake Lever	1
11	HB-38-16-250	Bolt $\frac{3}{8}$ - 16 x 2 $\frac{1}{2}$	2
	HW-38	Washer $\frac{3}{8}$	6
	HN-38-16	Nut $\frac{3}{8}$ - 16	2
12	11-100	Linkage Yoke $\frac{5}{16}$	1
13	HP-18-100	Cotter Pin $\frac{1}{8}$ x 1	1
	HCP- 516-125	Clevis Pin $\frac{5}{16}$ x 1 $\frac{1}{4}$	1
14	76-225	Brake Cable (with nuts)	1
	60-536	Bellows (one each end of brake cable)	2
15	HB-38-16-100	Bolt $\frac{3}{8}$ - 16 x 1 (holds 76-023 Valve)	2
	HWL-38	Lockwasher $\frac{3}{8}$	2
	HN-38-16	Nut $\frac{3}{8}$ - 16	2
16	76-199	Decal, Control Panel	1
17	76-265	Console	1
18	50-359	Warning Indicator Light	1
19	15-314	Electric Clutch Switch	1
	15-472	Switch Boot	1

DIESEL CONSOLE DRAWING

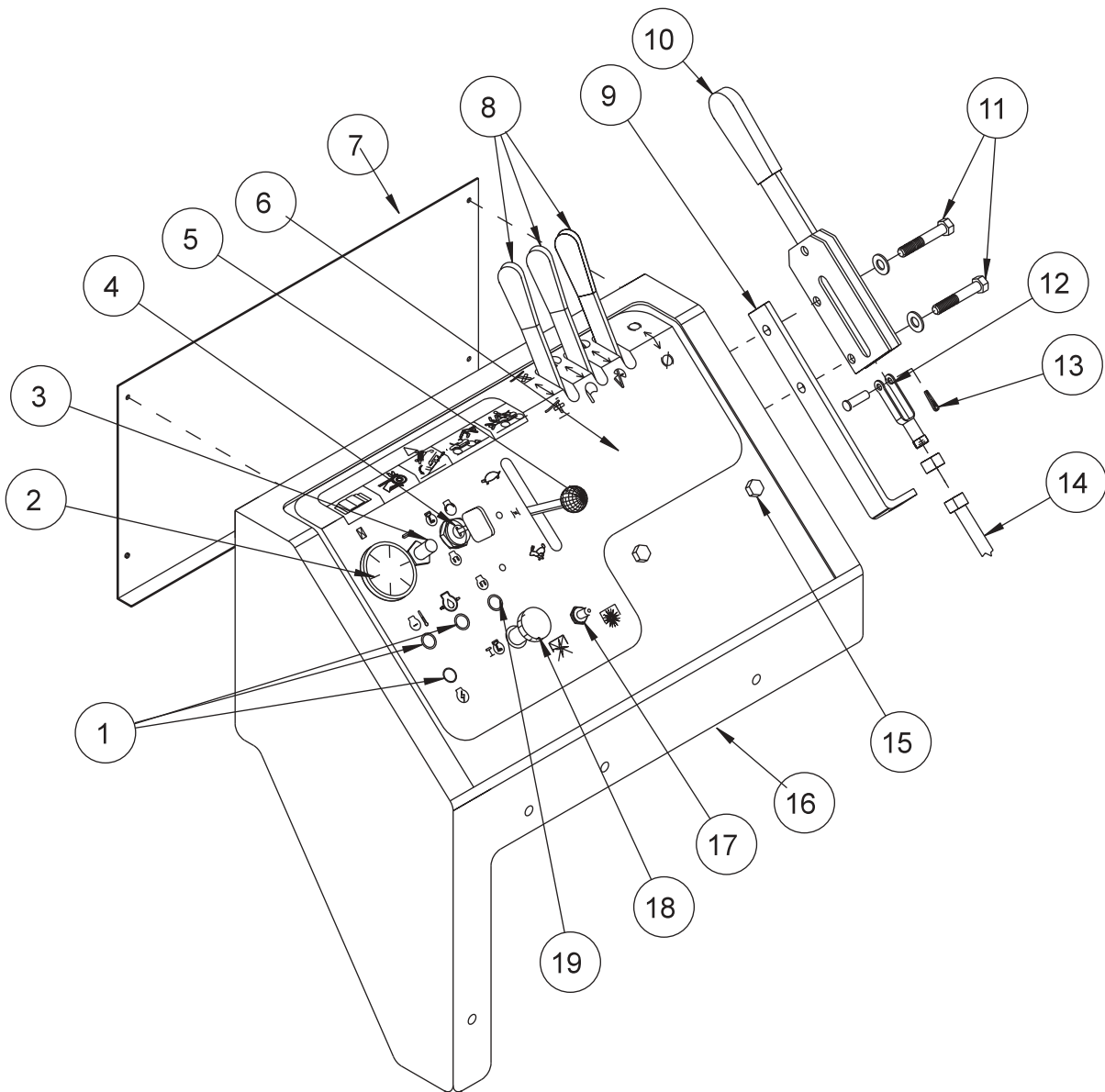

Parts

DIESEL CONSOLE PARTS LIST

REF#	PART#	DESCRIPTION	QUANTITY
1	50-359	Warning Indicator Light	3
2	12-017	Hour Meter	1
3	34-146	Panel Mount Circuit Breaker	1
	34-145	Circuit Breaker Boot	1
4	17-068	Key Switch	1
	17-079	Key Set	1
5	34-160	Throttle 48"	1
	34-159	Throttle Mounting Bracket	1
	HSM-10-32-063	Machine Screw 10 - 32 x $\frac{5}{8}$	4
	HSM-10-32-100	Machine Screw 10 - 32 x 1	2
	HWL-10	Lockwasher 10	6
	HN-10-32	Nut 10 - 32	6
6	77-178	Decal, Control Panel	1
7	76-214	Side Panel	1
	HSA-8-100	Tapping Screw #8 x 1	4
8	76-309	Valve Handle (with Linkage Kit)	1
	76-023	Hydraulic Valve (3 bank)	1
9	76-224	Park Brake Handle Mount	1
10	60-106	Brake Lever	1
11	HB-38-16-250	Bolt $\frac{3}{8}$ - 16 x $2\frac{1}{2}$	2
	HW-38	Washer $\frac{3}{8}$	6
	HN-38-16	Nut $\frac{3}{8}$ - 16	2
12	11-100	Linkage Yoke $\frac{5}{16}$	1
13	HP-18-100	Cotter Pin $\frac{1}{8}$ x 1	1
	HCP- 516-125	Clevis Pin $\frac{5}{16}$ x $1\frac{1}{4}$	1
14	76-225	Brake Cable (with nuts)	1
	60-536	Bellows (one each end of brake cable)	2
15	HB-38-16-100	Bolt $\frac{3}{8}$ - 16 x 1 (holds 76-023 Valve)	2
	HWL-38	Lockwasher $\frac{3}{8}$	2
	HN-38-16	Nut $\frac{3}{8}$ - 16	2
16	77-193	Console	1
17	15-314	Electric Clutch Toggle Switch	1
	15-472	Boot	1
18	77-206	Kill Control	1
	18-275	Ball Joint	1
19	77-211	Glow Plug Indicator Light	1



FUEL TANK AND OIL TANK DRAWING

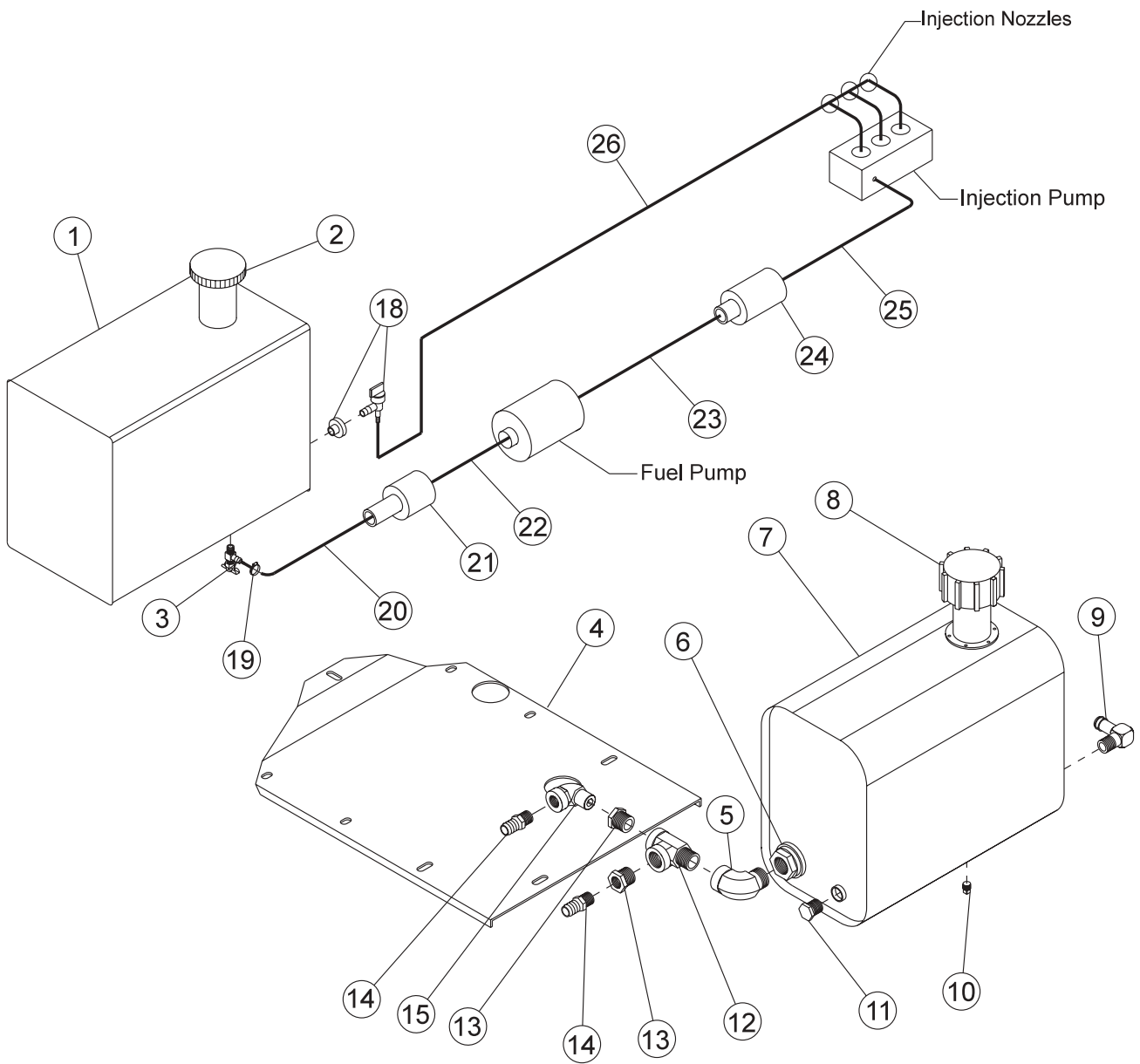

FUEL TANK AND OIL TANK PARTS LIST

REF#	PART#	DESCRIPTION	QUANTITY
1	15-491	Fuel Tank	1
	HB 14-20-075	Bolt $\frac{1}{4}$ - 20 x $\frac{3}{4}$	4
	HWL-14	Lockwasher $\frac{1}{4}$	4
	HW-14	Washer $\frac{1}{4}$	4
2	15-492	Gas Cap with Gauge	1
	77-179	Diesel Fuel Cap with Gauge	1
3	15-039	Fuel Valve	1
	18-042	Reducer Bushing $\frac{1}{4}$ x $\frac{1}{8}$	1
4	76-221	Tank Mount	1
5	18-140	Street Elbow $\frac{3}{4}$	1
6	60-213	Strainer	1
7	48-135	Oil Tank	1
8	13-586	Filler Breather	1
	13-586-01	Cap Gasket	1
	13-586-02	Bottom Gasket	2
9	23-142	Connector	1
	18-040	Hose Clamp	1
	8917-38	Suction Hose $\frac{5}{8}$ ID	1
10	18-118	Pipe Plug $\frac{1}{8}$	1
11	18-069	Pipe Plug $\frac{1}{2}$	1
12	18-093	Male Run Tee $\frac{3}{4}$	1
13	18-008	Pipe Reducer $\frac{3}{4}$ x $\frac{1}{2}$	2
14	18-133	Barb Fitting	2
15	18-009	Street Elbow $\frac{1}{2}$	1
18	26-054	Bushing Insert (part of tank)	1
	26-055	Shut-Off Valve (part of tank)	1
26	8800-64	Fuel Hose $\frac{1}{4}$ x 64	1
	8983-67	Fire Sleeve	1
	18-222	Hose Clamp	2

Diesel Sweeper Only

19	18-186	Hose Clamp $\frac{7}{32}$ - $\frac{5}{8}$	10
20	8800-14	Fuel Hose $\frac{1}{4}$ x 14	1
21	50-403	In-Line Fuel Filter	1
22	8800-49	Fuel Hose $\frac{1}{4}$ x 49	1
23	8800-16	Fuel Hose $\frac{1}{4}$ x 16	1
24	77-214	Fuel Filter Assembly	1
	17-043	Fuel Filter Element	1
25	8800-11	Fuel Hose $\frac{1}{4}$ x 11	1
26	8800-51	Fuel Hose $\frac{1}{4}$ x 51	1

OIL FILTER DRAWING

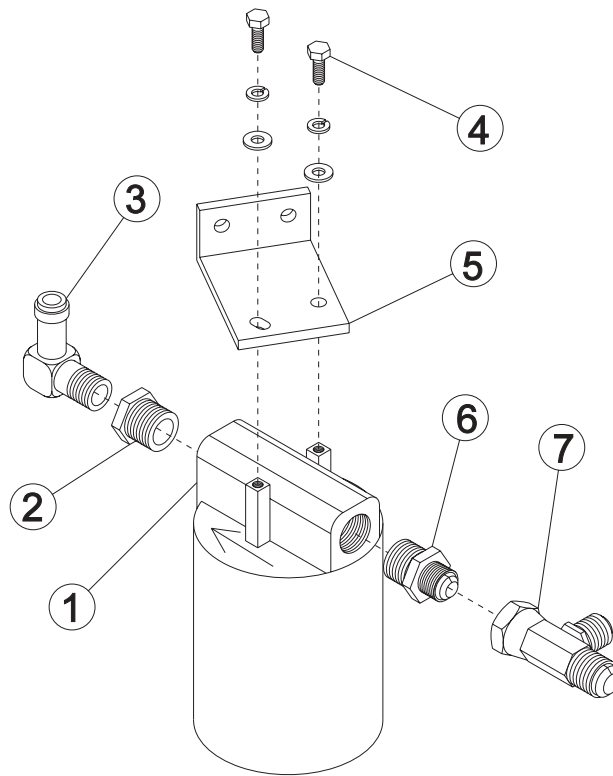

HYDRAULIC LIFT CYLINDER DRAWING

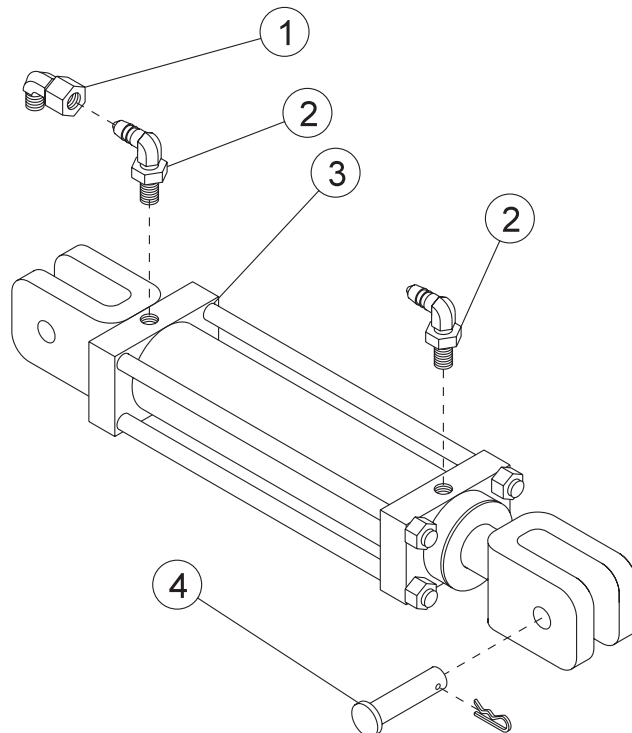

OIL FILTER PARTS LIST

REF#	PART#	DESCRIPTION	QUANTITY
1	23-006	Oil Filter	1
	23-031	Filter Element (replacement only)	1
2	18-008	Pipe Reducer $3/4 \times 1/2$	1
3	23-142	Connector	1
4	HB-14-20-075	Bolt $1/4 - 20 \times 3/4$	2
	HWL-14	Lockwasher $1/4$	2
	HW-14	Washer $1/4$	2
5	75-806	Filter Bracket	1
6	23-183	Male Connector	1
7	18-190	Tee	1

HYDRAULIC LIFT CYLINDER PARTS LIST

REF#	PART#	DESCRIPTION	QUANTITY
1	18-202	Elbow	1
2	23-167	Elbow	2
3	76-242	Hydraulic Cylinder	1
	76-242-01	Seal Kit	1
4	76-242-02	Clevis pin with Clip	2

Torque Specification

Piston Nut	165 ft/lbs (214.5 Nm)
Tie Rod Nut	30 ft/lbs (39 Nm)
Clevis Nut	46 ft/lbs (59.8 Nm)

REEL LIFT CYLINDER DRAWING

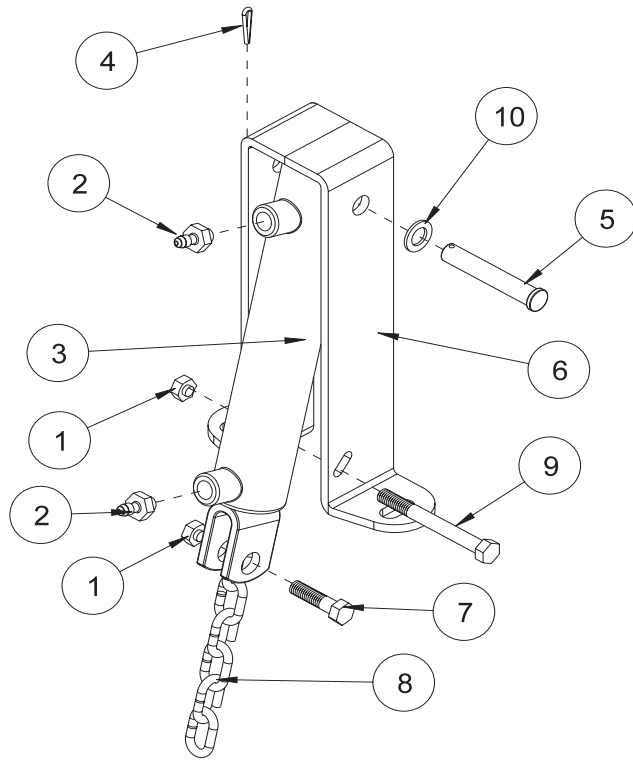

TAILGATE CYLINDER DRAWING

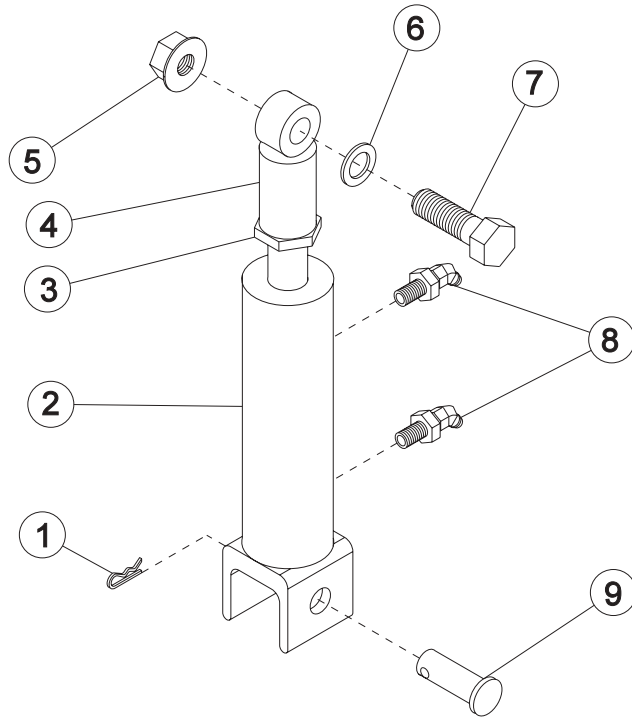

REEL LIFT CYLINDER PARTS LIST

REF#	PART#	DESCRIPTION	QUANTITY
1	HNTL-38-16	Lock Nut $\frac{3}{8}$ - 16	2
2	18-169	Adapter $\frac{3}{8}$ SAE	2
3	75-634	Hydraulic Cylinder 2 x 7 x $\frac{3}{4}$	1
4	HP-18-100	Cotter Pin $\frac{1}{8}$ x 1	1
5	HCP-12-350	Clevis Pin $\frac{1}{2}$ - 3 $\frac{1}{2}$	1
6	75-827	Cylinder Bracket	1
7	HB-38-16-150	Bolt $\frac{3}{8}$ - 16 x 1 $\frac{1}{2}$	1
8	8820-6	Machine Chain St. Link	1
9	HB-38-16-350	Bolt $\frac{3}{8}$ - 16 x 3 $\frac{1}{2}$	1
10	HMB-12-14	Machine Bushing $\frac{1}{2}$ x 14GA	1

Both Cylinders have the part number stamped on them. Look at the rod end, it will have either a retaining ring or a spanner nut.

Cylinders with a Spanner Nut:

50-456	Hydraulic Cylinder	Use	14-267	Seal Kit
75-634	Hydraulic Cylinder	Use	14-268	Seal Kit

Cylinders with a Retaining Ring:

50-456	Hydraulic Cylinder	Use	14-253	Seal Kit
75-634	Hydraulic Cylinder	Use	14-254	Seal Kit

TAILGATE CYLINDER PARTS LIST

REF#	PART#	DESCRIPTION	QUANTITY
1	HHP-18	Bridge Pin $\frac{1}{8}$	1
2	50-456	Hydraulic Cylinder 1 $\frac{1}{2}$ x 7	1
3	HNJ-58-18	Jam Nut $\frac{5}{8}$ - 18	1
4	18-154	Rod End	1
	HG-14-28-180	Grease Fitting $\frac{1}{4}$ - 28 x 180°	1
5	HNOT-58-11	Oval Top Lock $\frac{5}{8}$ - 11GA	1
6	HMB-58-14	Machine Bushing $\frac{5}{8}$ - 14GA	1
7	HB-58-11-200	Bolt $\frac{5}{8}$ - 11 x 2	1
8	18-168	Elbow	2
9	HCP-58-175	Clevis Pin $\frac{5}{8}$ x 1 $\frac{3}{4}$	1

Both Cylinders have the part number stamped on them. Look at the rod end, it will have either a retaining ring or a spanner nut.

Cylinders with a Spanner Nut:

50-456	Hydraulic Cylinder	Use	14-267	Seal Kit
75-634	Hydraulic Cylinder	Use	14-268	Seal Kit

Cylinders with a Retaining Ring:

50-456	Hydraulic Cylinder	Use	14-253	Seal Kit
75-634	Hydraulic Cylinder	Use	14-254	Seal Kit

KOHLER GAS ENGINE AND EXHAUST DRAWING

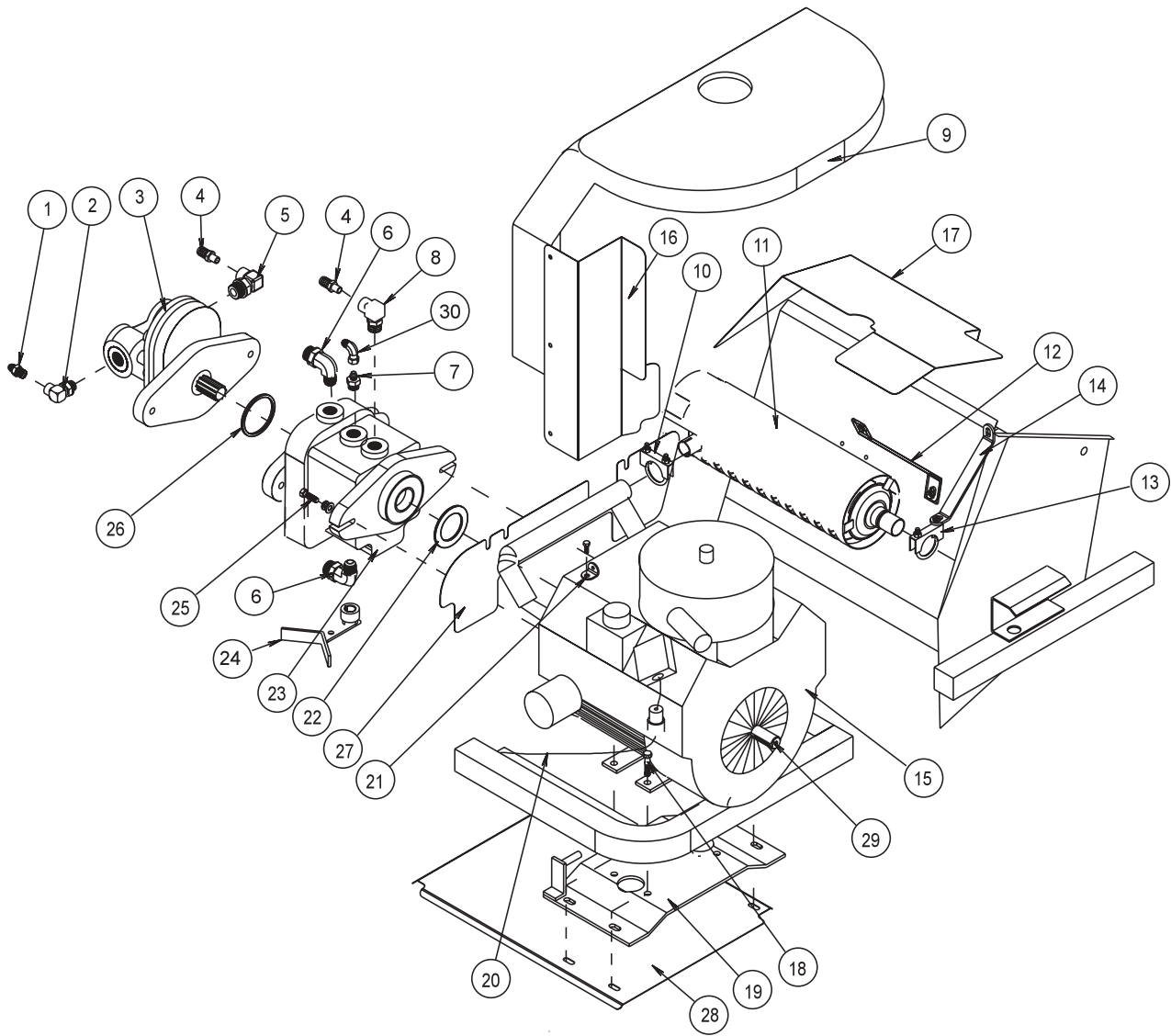

Parts

KOHLER GAS ENGINE AND EXHAUST PARTS LIST

REF#	PART#	DESCRIPTION	QUANTITY
1	23-188	Male Connector $\frac{3}{8}$	1
2	23-129	Elbow 90°	1
3	76-197	Gear Pump	1
4	18-133	Barb Fitting	2
5	23-133	Adjustable Elbow 90°	1
6	18-204	Elbow 90°	2
7	18-202	Elbow	1
8	23-130	Elbow 90°	1
9	76-266	Engine Cover	1
10	18-220	Muffler Clamp	1
11	76-348	Muffler	1
12	76-276	Hood Support	1
	HST-38-16-100	Truss Machine Screw $\frac{3}{8}$ - 16 x 1	2
	HW-38	Washer $\frac{3}{8}$	2
	HWL-38	Lockwasher $\frac{3}{8}$	2
	HN-38-16	Nut $\frac{3}{8}$ - 16	2
13	50-111	Muffler Clamp	1
14	76-236	Exhaust Bracket	1
	HB-38-16-100	Bolt $\frac{3}{8}$ - 16 x 1	1
	HW-38	Washer $\frac{3}{8}$	1
	HWL-38	Lockwasher $\frac{3}{8}$	1
	HN-38-16	Nut $\frac{3}{8}$ - 16	1
15	76-267	Kohler Command 25 hp Engine	1
	76-267-02	Crankshaft Splined Insert (part of engine)	1
	76-349	Stub Shaft (part of engine)	1
16	76-353	Front Engine Guard	1
	HB-14-20-100	Bolt $\frac{1}{4}$ - 20 x 1	3
	HW-14	Washer $\frac{1}{4}$	3
	HWL-14	Lock Washer $\frac{1}{4}$	3
	HN-14-20	Nut $\frac{1}{4}$ - 20	3
17	76-350	Debris Shield	1
18	HB-38-16-175	Bolt $\frac{3}{8}$ - 16 x $1\frac{3}{4}$	4
	HNTL-38-16	Lock Nut $\frac{3}{8}$ - 16	4
19	76-369	Motor Mount	1
20	8800-64	Fuel Hose $\frac{1}{4}$ x 64"	1
	18-186	Hose Clamp $\frac{1}{4}$	2
	8963-67	Fire Sleeve	1
	18-222	Hose Clamp	2
21	76-270	Throttle Cable Mount	1
	HB-14-20-075	Bolt $\frac{1}{4}$ - 20 x $\frac{3}{4}$	1
	HNTL-14-20	Lock Nut $\frac{1}{4}$ - 20	1
	21-161	Wire Block	1
22	23-145	O-Ring $3\frac{1}{4}$ ID x $3\frac{3}{8}$ OD	1
23	77-239	Hydrostatic Pump	1
24	77-241	Shift Arm	1
25	HB-38-16-125	Bolt $\frac{3}{8}$ - 16 x $1\frac{1}{4}$	2
	HW-38	Washer $\frac{3}{8}$	2
	HWL-38	Lockwasher $\frac{3}{8}$	2
26	77-130	Mounting Kit	1
27	76-351	Manifold Guard	1
28	76-352	Bottom Plate	1
29	76-349	Stub Shaft (part of engine)	1
30	18-241	Straight Thread Connector	1



KUBOTA DIESEL ENGINE AND EXHAUST DRAWING

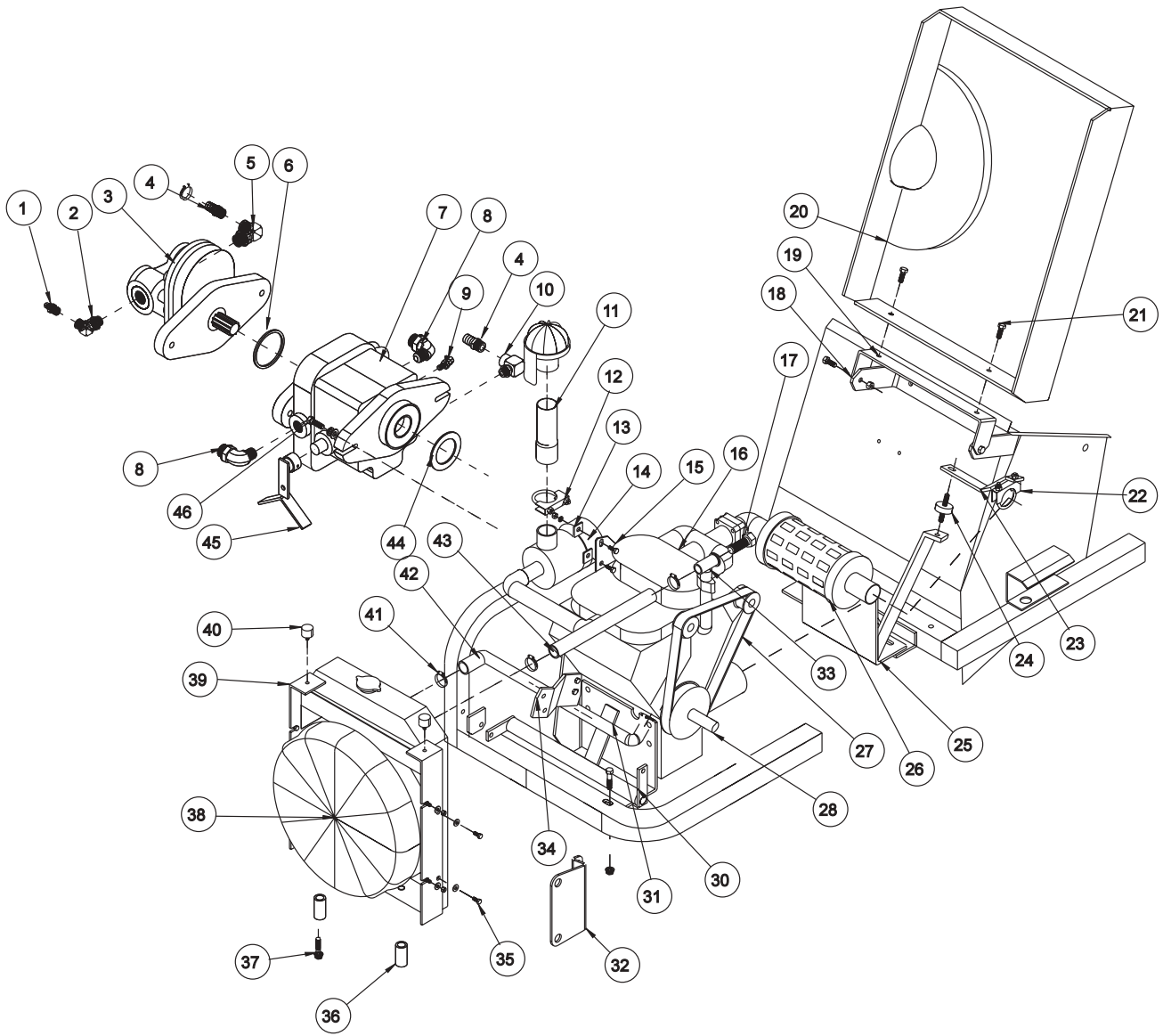

Parts

KUBOTA DIESEL ENGINE AND EXHAUST PARTS LIST

REF#	PART#	DESCRIPTION	QUANTITY
1	23-188	Male Connector $\frac{3}{8}$	1
2	23-129	Elbow 90°	1
3	76-197	Gear Pump	1
4	18-133	Barb Fitting	2
5	23-133	Adjustable Elbow 90°	1
6	77-130	Mounting Kit	1
7	77-239	Hydrostatic Pump	1
8	18-204	Elbow 90°	2
9	18-202	Elbow	1
10	23-130	Elbow 90°	1
11	77-196	Diesel Air Intake	1
12	50-394	Muffler Clamp, $1\frac{3}{4}$	1
13	11-132	Mounting Band (part of engine)	1
	HB-14-20-075	Bolt $\frac{1}{4}$ - 20 x $\frac{3}{4}$	2
	HWL-14	Lockwasher $\frac{1}{4}$	2
	HN-14-20	Nut $\frac{1}{4}$ - 20	2
14	77-221	Air Cleaner Assembly (part of engine)	1
	77-213	Air Cleaner Element	1
15	77-181	Air Cleaner Mount	1
	HBM-8-1-25	Metric Bolt #8 - 1 - 25	1
16	77-208	D-722 Diesel Kubota Engine	1
	77-208-02	Pump Housing	1
	77-208-03	Drive Shaft	1
17*	77-208-05	Air Pack Switch (part of engine)	1
18	77-182	Hood Hinge Mount	1
	HB-38-16-100	Bolt $\frac{3}{8}$ - 16 x 1	4
	HNTL-38-16	Lock Nut $\frac{3}{8}$ - 16	4
19	77-236	Hood Hinge	1
20	77-194	Engine Cover	1
21	HB-38-16-100	Bolt $\frac{3}{8}$ - 16 x 1	2
	HW-38	Washer $\frac{3}{8}$	2
	HWL-38	Lockwasher $\frac{3}{8}$	2
	HN-38-16	Nut $\frac{3}{8}$ - 16	2
22	50-111	Muffler Clamp $1\frac{1}{2}$	1
23	77-192	Muffler Brace	1
24	11-021	Rubber Mount	1
25	77-186	Rear Engine Mount	1
	HB-38-16-175	Bolt $\frac{3}{8}$ - 16 x $1\frac{3}{4}$	2
	HNTL-38-16	Lock Nut $\frac{3}{8}$ - 16	2
26	77-216	Muffler Assembly (part of engine)	1
	77-217	Muffler Gasket (part of engine)	1
27	77-212	Fan Belt (part of engine)	1
28	21-461	Pulley 2AK41 x 1	1
	HWK-14-100	Woodruff Key $\frac{1}{4}$ x 1	1
	77-242	Stub Shaft	1
	HWLI-516	Internal Lockwasher $\frac{5}{16}$	3
	HSSHSM-8-1.25-20	Socket Set Cap Screw Metric 8 - 1.25 x 20	3

(Continued on Next Page)

KUBOTA DIESEL ENGINE AND EXHAUST DRAWING (CONTINUED)

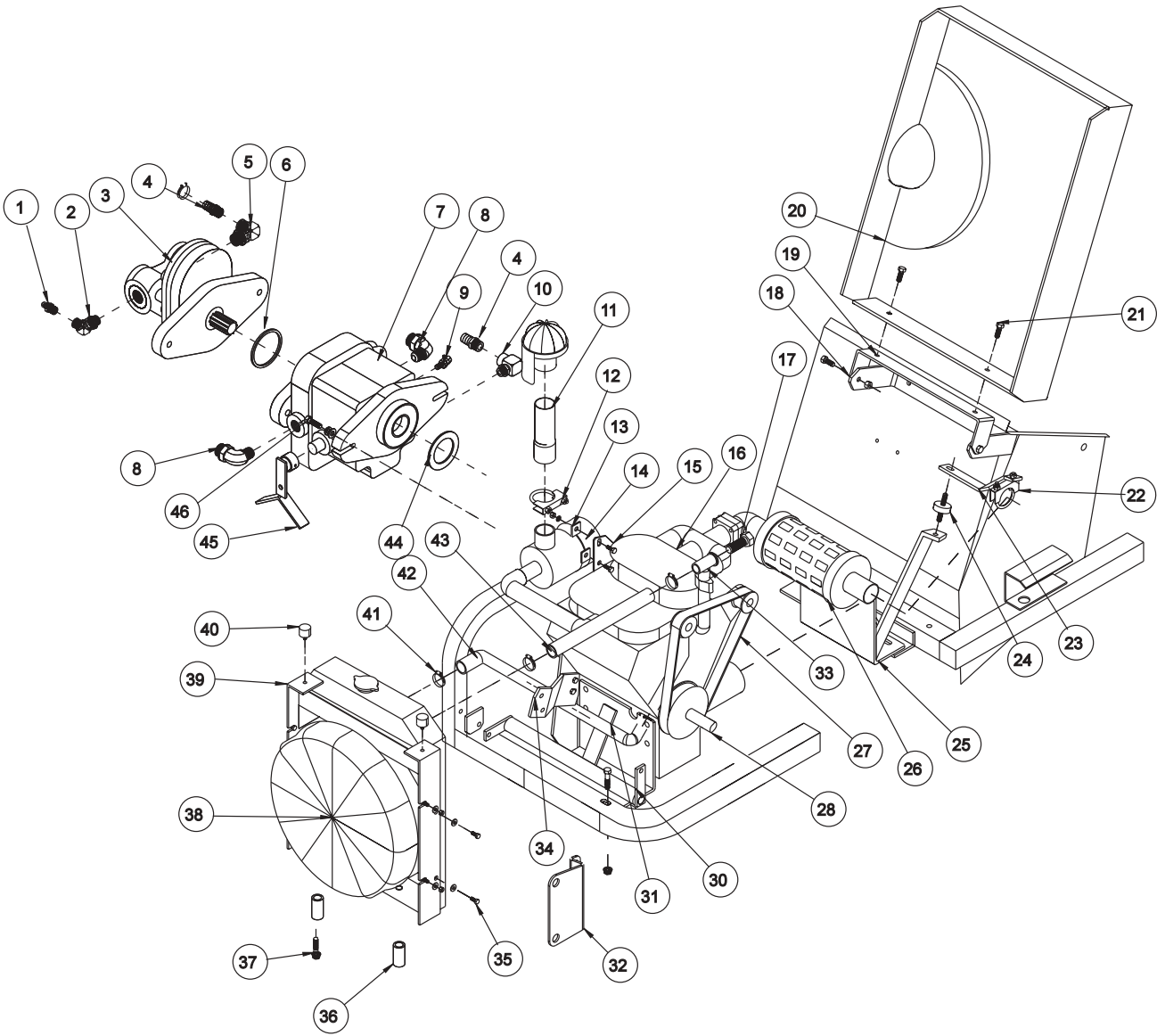

Parts

KUBOTA DIESEL ENGINE AND EXHAUST PARTS LIST (CONTINUED)

REF#	PART#	DESCRIPTION	QUANTITY
30	77-185	Front Engine Mount	1
	HB-38-16-175	Bolt $\frac{3}{8}$ - 16 x $1\frac{3}{4}$	2
	HNTL-38-16	Lock Nut $\frac{3}{8}$ - 16	2
31	8951-24	Lower Radiator Hose	1
32	77-243	Radiator Mount	1
33*	77-208-04	Gooseneck (part of engine)	1
34	77-184	Cable Bracket	1
	HBM-8-1-25	Metric Bolt #8 - 1 - 25	2
	HWLI-516	Internal Lockwasher $\frac{5}{16}$	2
35	HBM-6-1-16	Metric Bolt #6 - 1 - 16	8
	HW-14	Washer $\frac{1}{4}$	8
	HWL-14	Lockwasher $\frac{1}{4}$	8
	HNM-6	Metric Nut M6	4
36	60-406	Spacer	2
37	HBM-10-1.25-110	Metric Bolt 10 - 1.25 x 110	2
38	77-201	Electric Fan	1
	77-201-01	Motor Only 150 Watt	1
	77-201-02	Fan Blade	1
	77-201-03	Fan Shroud	1
39	77-238	Radiator Mount	1
40	15-013	Rubber Bumper	2
	HWL-14	Lockwasher $\frac{1}{4}$	2
	HN-14-20	Nut $\frac{1}{4}$ - 20	2
42	77-237	Radiator (on engine)	1
	77-225	Radiator Brace	1
41	18-222	Hose Clamp $\frac{13}{16}$ to $1\frac{1}{2}$	4
43	8951-11	Upper Radiator Hose	1
44	23-145	O-Ring $3\frac{1}{4}$ ID x $3\frac{3}{8}$ OD	1
45	76-227	Shift Arm	1
	HSSHS-516-18-050	Socket Head Set Screw $\frac{5}{16}$ - 18 x $\frac{1}{2}$	1
46	HB-38-16-125	Bolt $\frac{3}{8}$ - 16 x $1\frac{1}{4}$	2
-	HW-38	Washer $\frac{3}{8}$	2
	HWL-38	Lockwasher $\frac{3}{8}$	2
47	18-241	Straight Thread Connector	1
*	77-235	Thermostat Kit (includes * items)	

ELECTRIC CLUTCH DRIVEN BELT DRIVE DRAWING

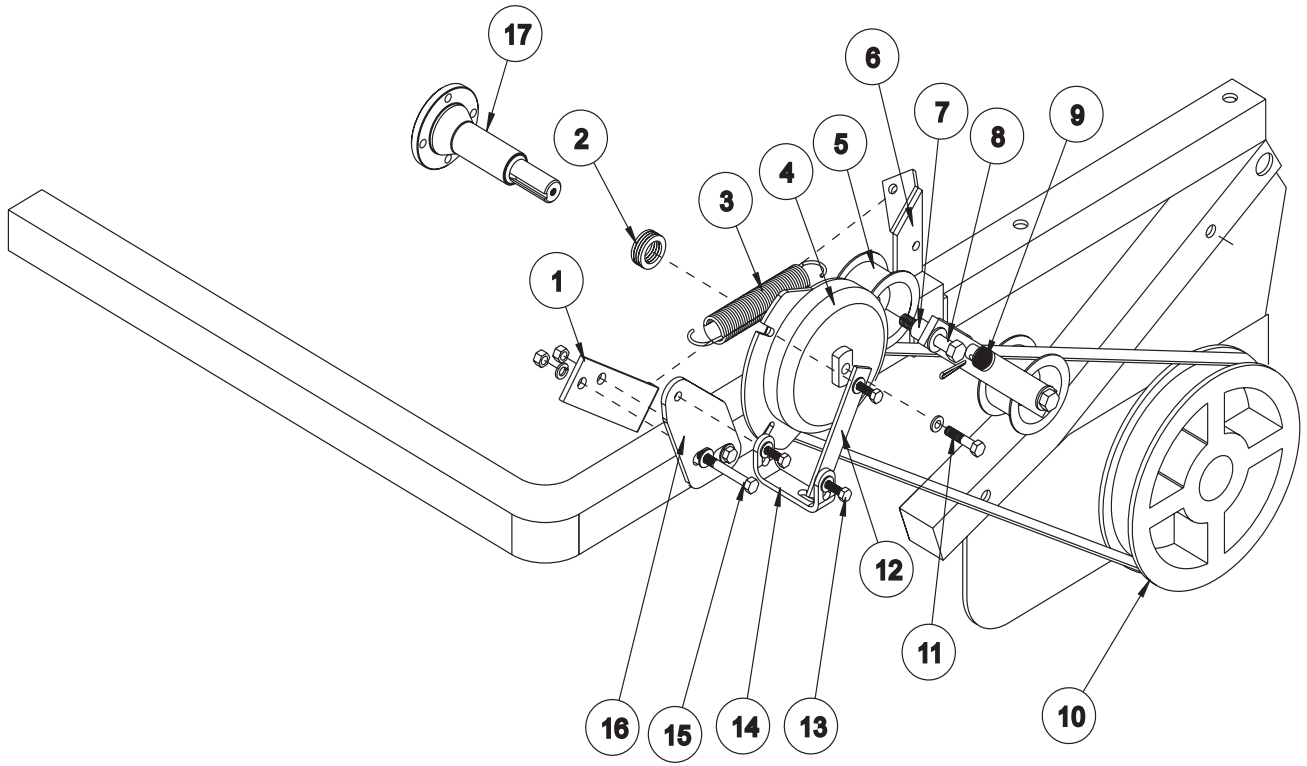

Parts

ELECTRIC CLUTCH DRIVEN BELT DRIVE PARTS LIST

REF#	PART#	DESCRIPTION	QUANTITY
1	48-038	Spring Bracket	1
2	HMB-100-10	Machine Bushing 1 x 10GA	4
3	21-445	Spring	1
4	76-337	Electric Clutch	1
5	16-013	Idler Pulley	2
6	76-217	Idler Arm	1
7	76-298	Spacer	2
8	HB-12-13-300	Bolt $\frac{1}{2}$ - 13 x 3	2
	HW-12	Washer $\frac{1}{2}$	2
	HNTL-12-13	Lock Nut $\frac{1}{2}$ - 13	2
9	HMB-12-14	Machine Bushing $\frac{1}{2}$ x 14GA	5
	HP-18-150	Cotter Pin $\frac{1}{8}$ x $1\frac{1}{2}$	1
10	76-102	Pulley 2AK104H	1
	76-102-01	Hub $1\frac{1}{4}$ ID	1
	HKSQ-14-150	Machine Key $\frac{1}{4}$ x $\frac{1}{4}$ x $1\frac{1}{2}$	1
	76-200	Belt 2/A74	1
11	HB-38-16-175	Bolt $\frac{3}{8}$ - 16 x $1\frac{3}{4}$	1
	HWL-38	Lock Washer $\frac{3}{8}$	1
12	76-340	Clutch Strap	1
13	HB-516-18-100	Bolt $\frac{5}{16}$ - 18 x 1	3
	HW-516	Washer $\frac{5}{16}$	3
	HNTL-516-18	Lock Nut $\frac{5}{16}$ - 18	3
14	76-339	Belt Guard Support	1
15	HB-38-16-300	Bolt $\frac{3}{8}$ - 16 x 3	2
	HW-38	Washer $\frac{3}{8}$	2
	HWL-38	Lock Washer $\frac{3}{8}$	2
	HN-38-16	Nut $\frac{3}{8}$ - 16	2
16	76-338	Clutch Mount	1
17	76-349	Stub Shaft (Gas)	1
	77-242	Stub Shaft (Diesel)	1

FINGER REEL DRAWING

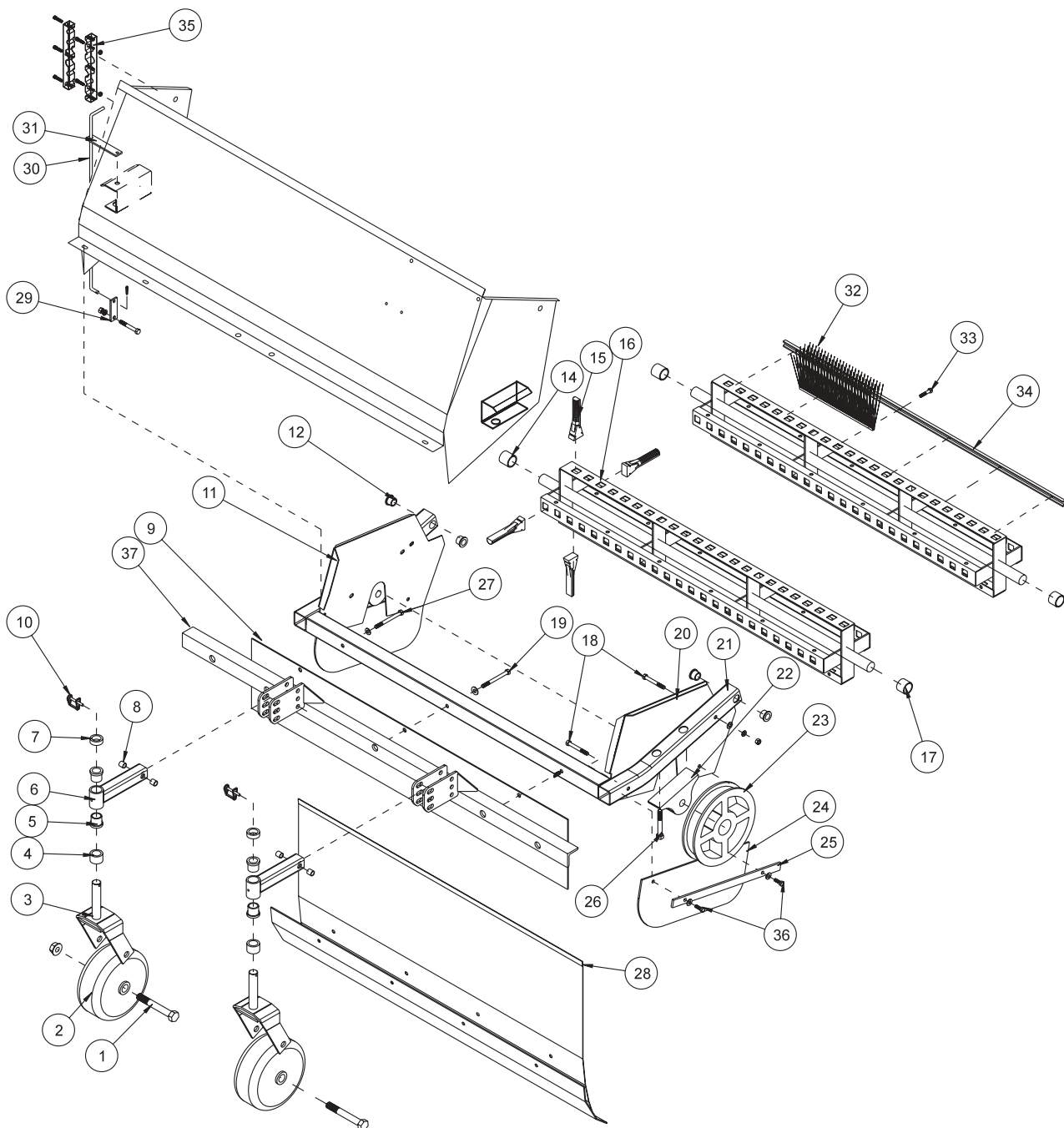

Parts

FINGER REEL PARTS LIST

REF#	PART#	DESCRIPTION	QUANTITY
1	HB-34-10-550	Bolt $\frac{3}{4}$ - 10 x $5\frac{1}{2}$	2
	HNTL-34-10	Lock Nut $\frac{3}{4}$ - 10	2
2	33-435	Tire and Wheel	2
3	48-046	Castor Fork	2
4	29-585	Spacer Height Adjustment	2
5	18-223	Bushing (part of 76-355)	2 per
6	76-355	Arm	2
7	29-584	Height Adjustment Spacer $\frac{1}{2}$ "	2
8	20-019	Bushing (part of 76-355)	2 per
9	76-119	Mud Guard	1
10	29-541	Lock Pin $\frac{1}{4}$	2
11	75-799	Side Plate RH.	1
12	18-221	Flange Bushing(part of 75-787)	4
14	75-686	Spacer $1\frac{1}{4}$ ID x $1\frac{3}{8}$	1
15	75-506	Sweeper Finger	116
16	75-780	Finger Reel	1
17	75-834	Spacer $1\frac{1}{4}$ ID x $1\frac{1}{8}$	1
18	HB-38-16-300	Bolt $\frac{3}{8}$ - 16 x 3	3
	HB-38-16-275	Bolt $\frac{3}{8}$ - 16 x $2\frac{3}{4}$	4
	HW-38	Washer $\frac{3}{8}$	7
	HNTL-38-16	Lock Nut $\frac{3}{8}$ - 16	4
19	HB-38-16-450	Bolt $\frac{3}{8}$ - 16 x $4\frac{1}{2}$	1
	HW-38	Washer $\frac{3}{8}$	2
	HWL-38	Lockwasher $\frac{3}{8}$	1
	HN-38-16	Nut $\frac{3}{8}$ - 16	1
20	75-800	Left Side Plate	1
21	75-787	Reel Frame	1
22	75-511	Pillow Block $1\frac{1}{4}$ Bore	2
23	76-102	Pulley with Hub	1
	76-102-01	Hub $1\frac{1}{4}$ ID	1
	HMB-114-10	Machine Bushing $1\frac{1}{4}$ x 10 GA	2 As Req'd
	HMB-114-14	Machine Bushing $1\frac{1}{4}$ x 14 GA	1 As Req'd
24	76-210	Matting $7\frac{1}{2}$ x 18	2
25	76-213	Reel Guard Strap	2
26	HB-12-13-350	Bolt $\frac{1}{2}$ - 13 x $3\frac{1}{2}$	4
	HW-12	Washer $\frac{1}{2}$	4
	HNCL-12-13	Center Lock Nut $\frac{1}{2}$ - 13	4
27	HB-38-16-350	Bolt $\frac{3}{8}$ - 16 x $3\frac{1}{2}$	2
	HW-38	Washer $\frac{3}{8}$	4
	HNTL-38-16	Lock Nut $\frac{3}{8}$ - 16	2
28	75-808	Front Baffle	1
29	76-278	Bottom Mount	1
	HB-38-16-300	Bolt $\frac{3}{8}$ - 16 x 3	1
	HWL-38	Lockwasher $\frac{3}{8}$	1
	HN-38-16	Nut $\frac{3}{8}$ - 16	1
30	76-277	Height Indicator Rod	1
31	76-279	Top Mount	1
32	76-330	Brush	4
33	HB-516-18-125	Bolt $\frac{5}{16}$ - 18 x $1\frac{1}{4}$	28
	HNTL-516-18	Lock Nut $\frac{5}{16}$ - 18	28
34	76-313	Clamp	4
35	76-336	Hose Clamp	1
36	HB-516-18-100	Bolt $\frac{5}{16}$ - 18 x 1	4
	HW-516	Washer $\frac{5}{16}$	8
	HNTL-516-18	Lock Nut $\frac{5}{16}$ - 18	4
37	76-356	Castor Mount Bracket	1
	HCP-12-150	Clevis Pin $\frac{1}{2}$ x $1\frac{1}{2}$	4
	HHP-18	Bridge Pin $\frac{1}{8}$	4

REAR AXLE DRAWING

Parts

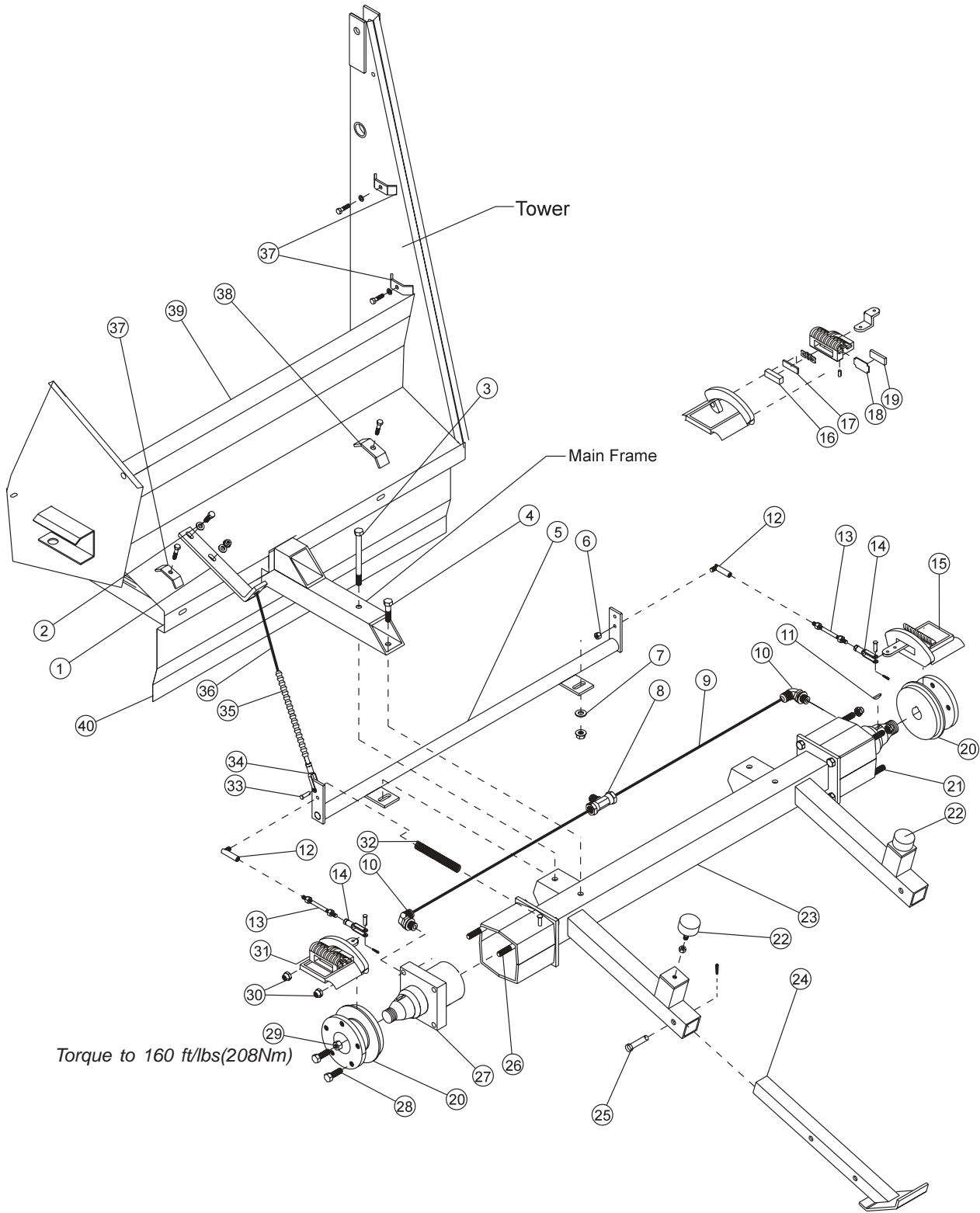

REAR AXLE PARTS LIST

REF#	PART#	DESCRIPTION	QUANTITY
1	76-218	Brake Cable Bracket	1
2	HB-38-16-125	Bolt $\frac{3}{8}$ - 16 x $1\frac{1}{4}$	2
	HW-38	Washer $\frac{3}{8}$	4
	HNTL-38-16	Lock Nut $\frac{3}{8}$ - 16	2
3	HB-12-13-450	Bolt $\frac{1}{2}$ - 13 x $4\frac{1}{2}$	2
	HNTL-12-13	Lock Nut $\frac{1}{2}$ - 13	2
4	HB-12-13-400	Bolt $\frac{1}{2}$ - 13 x 4	2
5	76-229	Park Brake Relay	1
6	HN-516-24	Nut $\frac{5}{16}$ - 24	2
	HWL-516	Lockwasher $\frac{5}{16}$	2
7	HW-12	Washer $\frac{1}{2}$	2
	HNTL-12-13	Lock Nut $\frac{1}{2}$ - 13	2
8	34-057	Tee Fitting	2
9	76-208	Hydraulic Hose 23.5"	4
10	34-122	Short 90° Elbow	4
11	HWK-516-100	Woodruff Key $\frac{5}{16}$ x 1	2
12	21-462	Ball Joint $\frac{5}{16}$ - 24	2
13	76-300	Brake Rod	2
	HN-516-24	Nut $\frac{5}{16}$ - 24	4
14	11-100	Linkage Yoke $\frac{5}{16}$	2
	HCP-516-100	Clevis Pin $\frac{5}{16}$ x 1	2
	HP-18-075	Cotter Pin $\frac{1}{8}$ x $\frac{3}{4}$	2
15	76-241	Right Caliper Clockwise	1
16*		Cam Side Pad	1
17*		Cam Side Pad Support	1
18*		Carrier Side Pad Support	1
19*		Carrier Side Pad	1
20	76-239	Brake Disk 8" 5 Hole	2
21	HB-12-13-750	Bolt $\frac{1}{2}$ - 13 x $7\frac{1}{2}$	4
	HNTL-12-13	Lock Nut $\frac{1}{2}$ - 13	4
22	50-081	Rubber Bumper	2
	HN-38-16	Nut $\frac{3}{8}$ - 16	2
23	76-226	Rear Axle	1
24	75-723	Rear Skid	2
25	HCP-12-225	Clevis Pin $\frac{1}{2}$ x $2\frac{1}{4}$	2
	HHP-18	Bridge Pin $\frac{1}{8}$	2
26	HB-12-13-800	Bolt $\frac{1}{2}$ - 13 x 8	4
27	76-238	Wheel Motor (Includes Ref. #11 & Ref. #29)	2
28	60-268	Lug Nut $\frac{1}{2}$ - 20 x $1\frac{5}{16}$	10
29	14-265	Nut 1 - 20	2
30	HNTL-12-13	Lock Nut $\frac{1}{2}$ - 13	4
31	76-240	Left Caliper Counterclockwise	1
32	29-118	Zinc Plated Spring	1
33	HCP-516-100	Clevis Pin $\frac{5}{16}$ x 1	1
34	11-100	Linkage Yoke $\frac{5}{16}$	1
	HN-516-24	Nut $\frac{5}{16}$ - 24	1
35	60-536	Bellows	2
36	76-225	Brake Cable with Nuts	1
37	13-099	Hose Clamp	3
	HB-516-18-125	Bolt $\frac{5}{16}$ - 18 x $1\frac{1}{4}$	2
	HWL-516	Lockwasher $\frac{5}{16}$	2
	HB-516-18-150	Bolt $\frac{5}{16}$ - 18 x $1\frac{1}{2}$	1
	HNTL-516-18	Lock Nut $\frac{5}{16}$ - 18	1
38	75-614	Hose Clamp	1
	HB-516-18-150	Bolt $\frac{5}{16}$ - 18 x $1\frac{1}{2}$	1
	HNTL-516-18	Lock Nut $\frac{5}{16}$ - 18	1
39	76-234	Rear Chute Baffle	1
40	76-233	Rear Beater Panel	1
*	34-101-02	Pad Kit with 2 Pads and Steel Backing Plates	2 Kits Req'd per Axle



HOPPERDRAWING

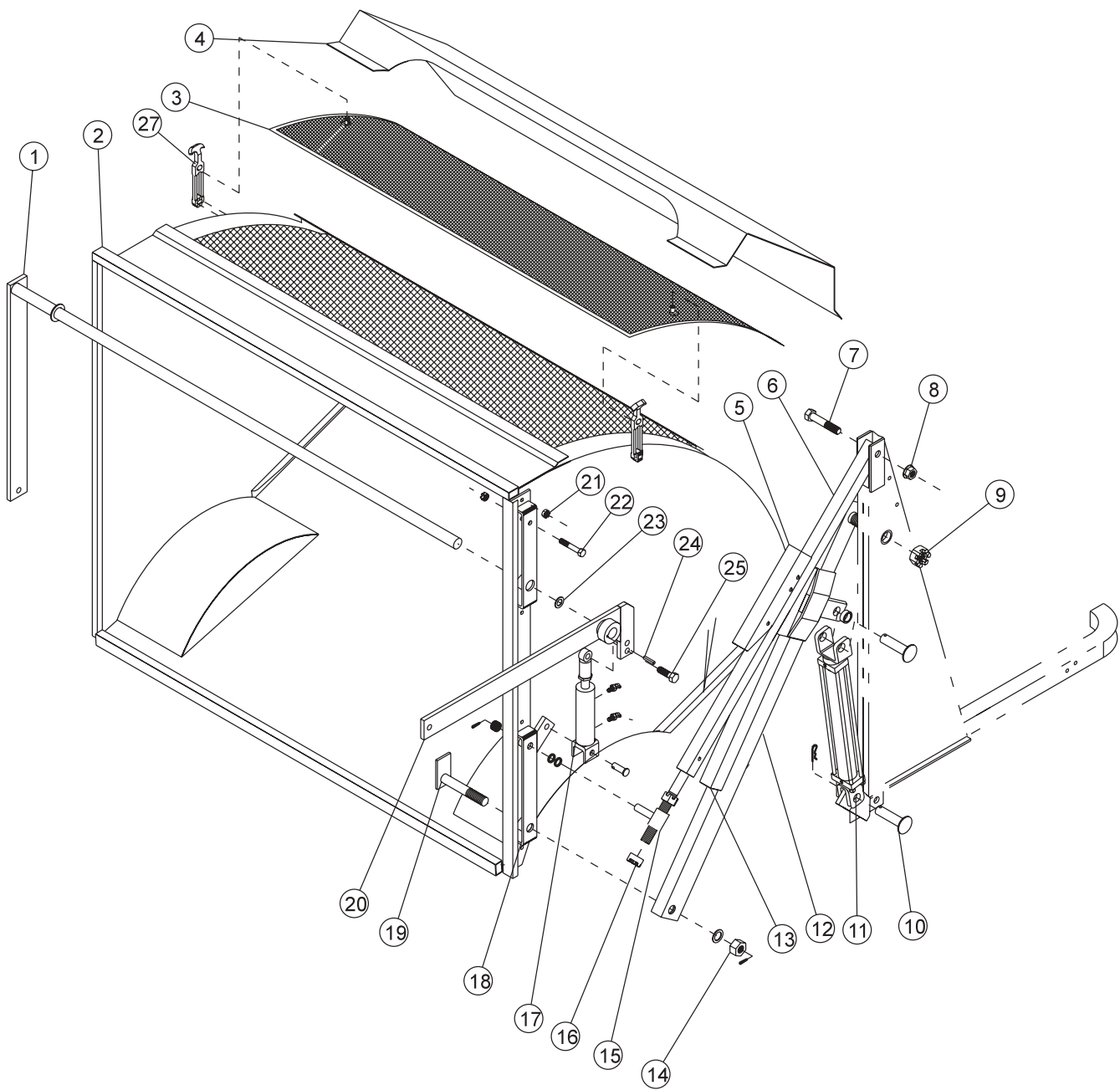

Parts

HOPPER PARTS LIST

REF#	PART#	DESCRIPTION	QUANTITY
1	75-566	Tailgate Dump Bar	1
	HMB-114-10	Machine Bushing 1 ¹ / ₄ x 10 GA	1
2	76-237	Hopper	1
3	76-261	Hopper Screen	1
4	76-359	Hopper Screen Cover	1
	HB-516-18-100	Bolt ⁵ / ₁₆ -18 x 1	6
	HNFL-516-18	Flange Whiz Lock Nut ⁵ / ₁₆ - 18	6
5	75-653	Hopper Safety Lift	2
	HB-38-16-250	Bolt ³ / ₈ - 16 x 2 ¹ / ₂	4
	HNW-38-16	Wing Nut ³ / ₈ - 16	4
6	76-230	Hopper Dump Arm	2
	HNA-100-14	Slotted Hex Nut 1 - 14	2
7	HB-34-10-400	Bolt ³ / ₄ - 10 x 4	2
	HMB-34-10	Machine Bushing ³ / ₄ - 10GA	2
8	HNTL-34-10	Lock Nut ³ / ₄ - 10	2
9	HNAT-125-12	Thick Axle Nut 1 ¹ / ₄ - 12	2
10	76-242-02	Clevis Pin with/ Clip	2
11	76-242	Hydraulic Cylinder	2
12	76-211	Arm Pivot Tube	1
	76-161	Hose Guard, Short	1
	HSDPS-14-075	Stainless Steel Pan Head Drill Screw ¹ / ₄ x ³ / ₄	2
13	76-159	Hose Guard, Long	1
	HSDPS-14-075	Drill Screw ¹ / ₄ x ³ / ₄	2
14	HMB-100-10	Stainless Steel Pan Head Machine Bushing 1 x 10GA	2
	HNA-100-14	Slotted Hex Nut 1 - 14	2
	HP-18-150	Cotter Pin ¹ / ₈ x 1 ¹ / ₂	2
15	75-632	Adjustment Sleeve	2
	HMB-34-14	Machine Bushing ³ / ₄ x 14GA	2
	HMB-34-10	Machine Bushing ³ / ₄ x 10GA	8
	HP-18-150	Cotter Pin ¹ / ₈ x 1 ¹ / ₂	2
16	75-704	Castle Nut 1 - 14	2
17	50-456	Hydraulic Cylinder 1 ¹ / ₂ x 7	1
	18-168	Elbow	2
	18-154	Rod End	1
	HG-14-28-180	Grease Fitting ¹ / ₄ - 28 x 180° (part of rod end)	1
	HCP-58-175	Clevis Pin ⁵ / ₈ x 1 ³ / ₄	1
	HHP-18	Bridge Pin ¹ / ₈	1
18	76-215	Right Hinge Strap (Shown)	1
	76-216	Left Hinge Strap	1
19	75-569	Swivel Pin	2
20	75-568	Right Tailgate Dump Bar	1
21	HN-38-16	Nut ³ / ₈ - 16	8
	HWL-38	Lockwasher ³ / ₈	8
	HB-38-16-100	Bolt ³ / ₈ - 16 x 1	8
22	HB-12-13-300	Bolt ¹ / ₂ - 13 x 3	2
	HN-12-13	Nut ¹ / ₂ - 13	2
	HNCL-12-13	Center Lock Nut ¹ / ₂ - 13	2
23	HMB-114-10	Machine Bushing 1 ¹ / ₄ x 10GA	2 As Req'd
24	HKSQ-14-150	Machine Key ¹ / ₄ x ¹ / ₄ x 1 ¹ / ₂	1
	HSSHS-38-16-038	Set Screw ³ / ₈ - 16 x ³ / ₈	1
	HRP-38-250	Roll Pin ³ / ₈ x 2 ¹ / ₂	1
25	HB-58-11-200	Bolt ⁵ / ₈ - 11 x 2	1
	HMB-58-14	Machine Bushing ⁵ / ₈ x 14GA	1
	HNCL-58-11	Center Lock Nut ⁵ / ₈ - 11	1
*26	76-288	Spacer	2
27	15-437	Latch	2
	HRS-316-1125	Rivet ³ / ₁₆ X 1 ¹ / ₈	6
	HW-8	Washer #8	6
	HW-10	Washer #10	2

*Spacer **MUST** be to the outside of the tab on the Pivot Arm with the tab and the spacer inside the cylinder yoke.



TAILGATE DRAWING

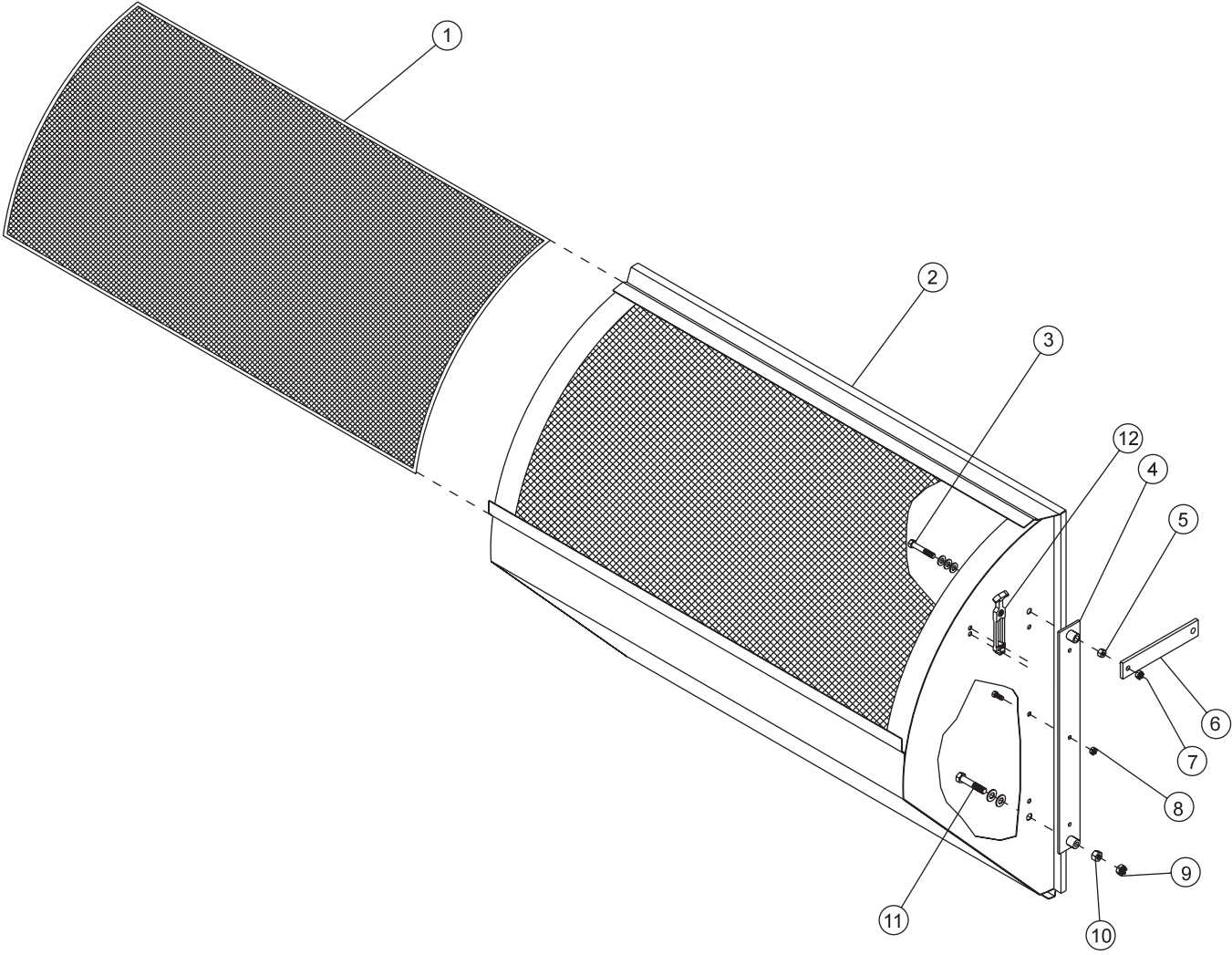

Parts

TAILGATE PARTSLIST

REF#	PART#	DESCRIPTION	QUANTITY
1	76-262	Tailgate Screen	1
2	76-243	Tailgate	1
3	HB-12-13-300	Bolt $\frac{1}{2}$ - 13 x 3	2
	HMB-12-14	Machine Bushing $\frac{1}{2}$ x 14GA	6
4	75-565	Tailgate Hinge Strap	2
5	HN-12-13	Nut $\frac{1}{2}$ - 13	2
6	75-564	Tailgate Hinge	2
7	HNCL-12-13	Center Lock Nut $\frac{1}{2}$ - 13	2
8	HNCL-38-16	Center Lock Nut $\frac{3}{8}$ - 16	6
	HB-38-16-100	Bolt $\frac{3}{8}$ - 16 x 1	6
9	HNTL-58-18	Lock Nut $\frac{5}{8}$ - 18	2
10	HNJ-58-18	Jam Nut $\frac{5}{8}$ - 18	2
11	HB-58-18-325	Bolt $\frac{5}{8}$ - 18 x $3\frac{1}{4}$	2
	HMB-58-14	Machine Bushing $\frac{5}{8}$ x 14GA	4
12	15-437	Latch	2
	HRS-316-1125	Rivet Steel $\frac{3}{16}$ x $1\frac{1}{8}$	3
	HW-10	Washer 10	3
NS	8828-60	Weather Stripping (60")	1

77-239 EATON HYDROSTATIC PUMP DRAWING

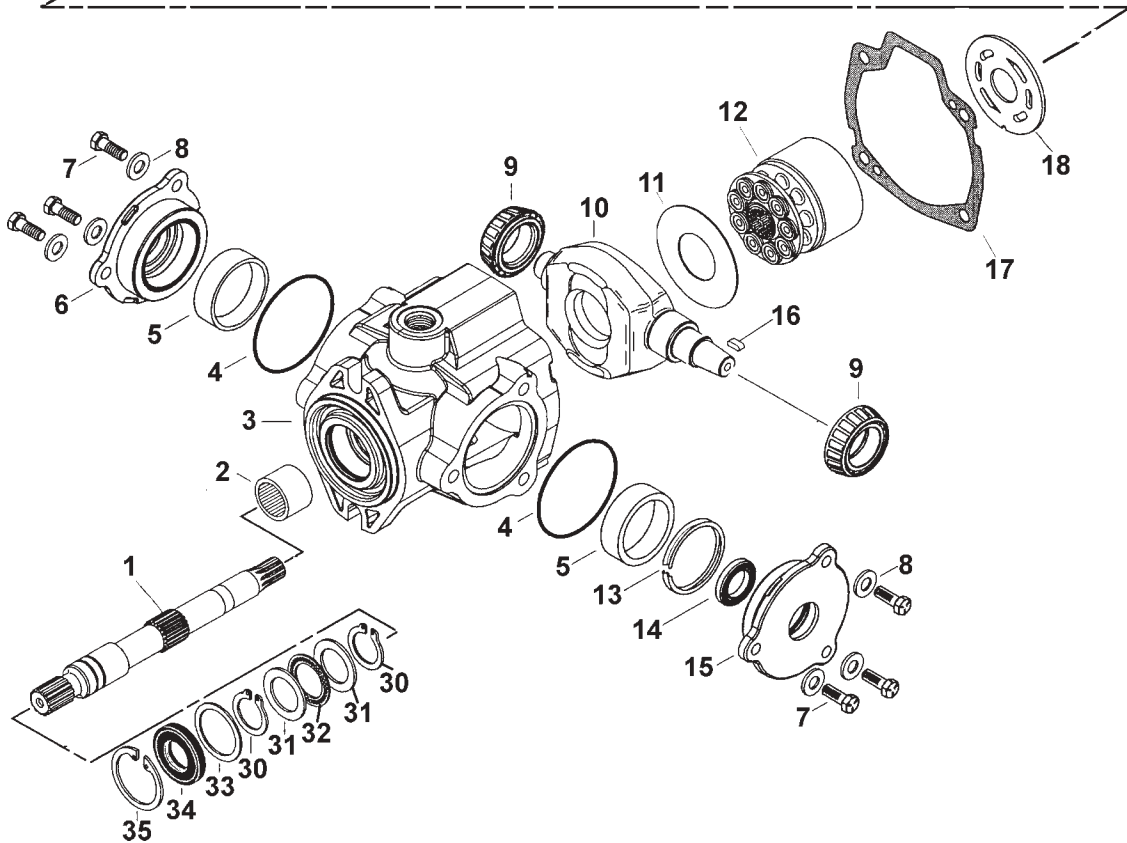
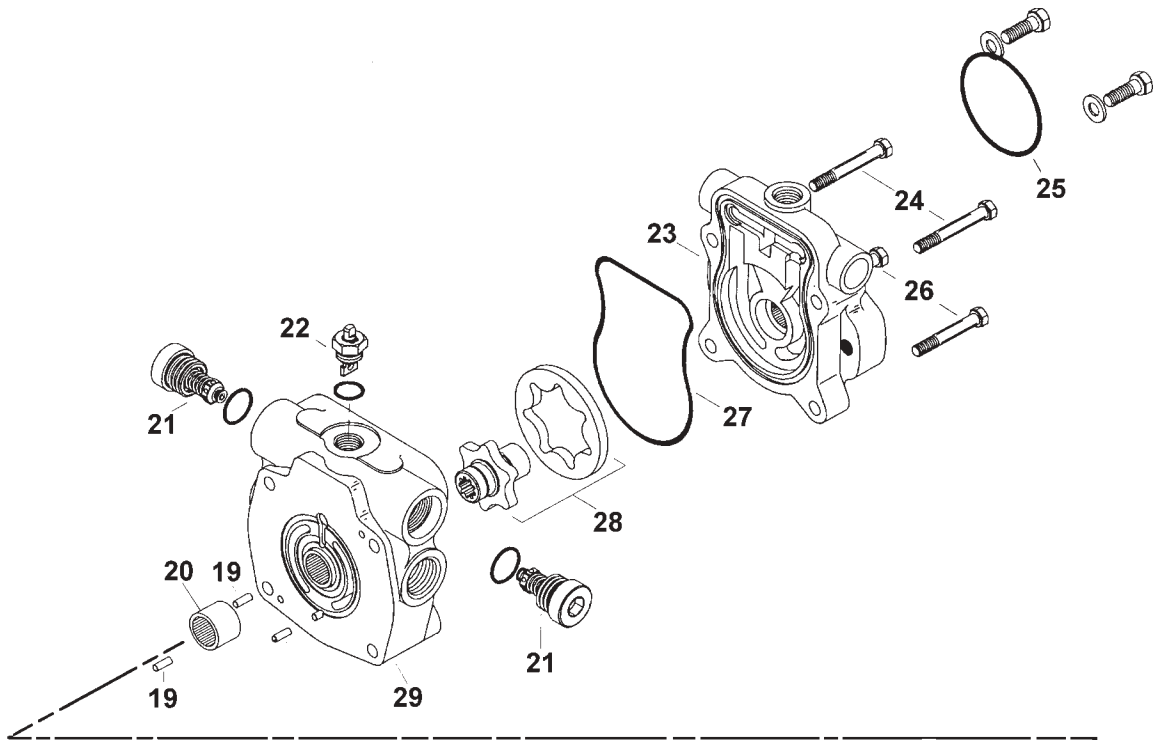

Parts

77-239 EATON HYDROSTATIC PUMP PARTS LIST

REF#	PART#	DESCRIPTION	QUANTITY
1	60-343-52	Drive Shaft (splined)	1
2	60-343-08	Needle Bearing (with housing)	1
3	77-239-01	Housing	1
4	77-239-02	O-Ring	1
5	77-239-03	Thrust Bearing	2
6	77-239-04	Trunnion Cover	1
7	77-239-05	Pan Head Screw	2
8	77-239-06	Washer	6
9	77-239-07	Cone Bearing	2
10	77-239-08	Cam Plate	1
11	77-239-09	Swash Plate Insert	1
12	60-343-21	Rotating Kit	1
13	77-239-10	Crush Ring	1
14*	60-343-12	Shaft Seal	1
15	77-239-11	Seal Cover	1
16	77-239-12	Key	1
17*	77-239-13	Gasket	1
18	77-239-14	Back Plate	1
19	33-058-27	Dowel Pin	2
20	60-343-23	Bearing	1
21	77-239-15	Relief Valve (4000 psi)	2
22	77-239-16	Tow Valve Assembly	1
23	76-160	Charge Pump Adaptor	1
24	77-239-17	Cap Screw	2
25*	77-130	O-Ring (mounting kit)	1
26	77-239-18	Cap Screw	2
27*	77-239-19	O-Ring	1
28	60-343-43	Gerotor and Coupler	1
29	77-239-20	Endcover Assembly	1
30*	77-239-21	Retaining Ring	2
31	60-343-05	Bearing Race	1
32	60-343-06	Thrust Bearing	1
33	60-343-03	Washer	2
34*	60-343-02	Shaft Seal	1
35*	60-343-01	Retaining Ring	1

* 77-239-22

Seal Kit

76-197 EATON GEAR PUMP DRAWING

Parts

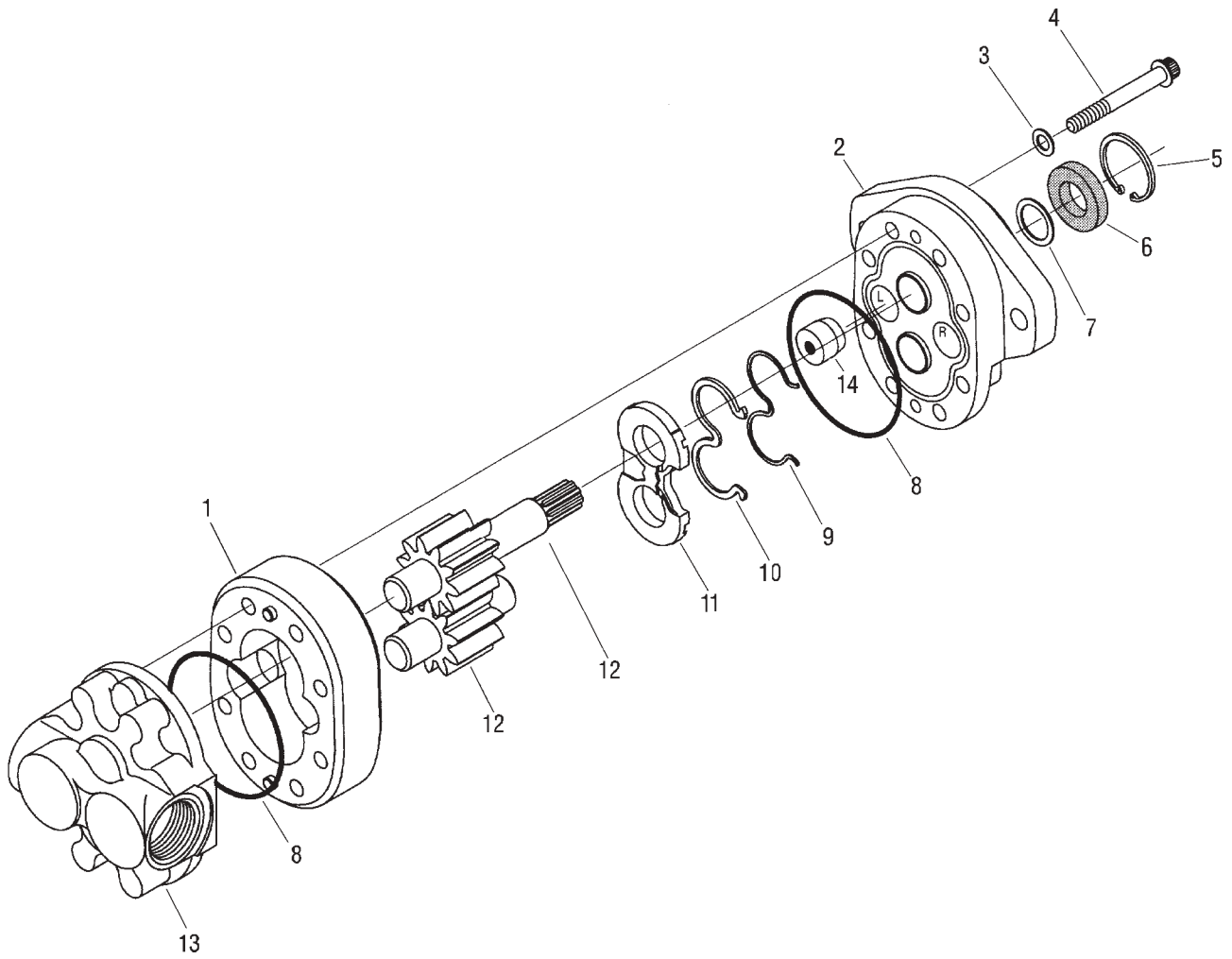

76-197 EATON GEAR PUMP PARTS LIST

REF#	PART#	DESCRIPTION	QUANTITY
1		Body	1
2	76-197-01	Front Plate	1
3*		Washer	4
4	76-197-06	Cap Screw	8
5	76-197-07	Retaining Ring	1
6*		Shaft Seal	1
7	33-061-15	Washer	1
8*		O-Ring	2
9*		Backup Gasket	1
10*		Seal	1
11*		Wear Plate	1
12	76-197-04	Shaft (comes with Idler Gear)	1
13	76-197-02	Back Plate	1
14*		Plug	1
*	76-197-08	Seal Kit	

76-238 REAR WHEEL MOTOR DRAWING (14.5 CI)

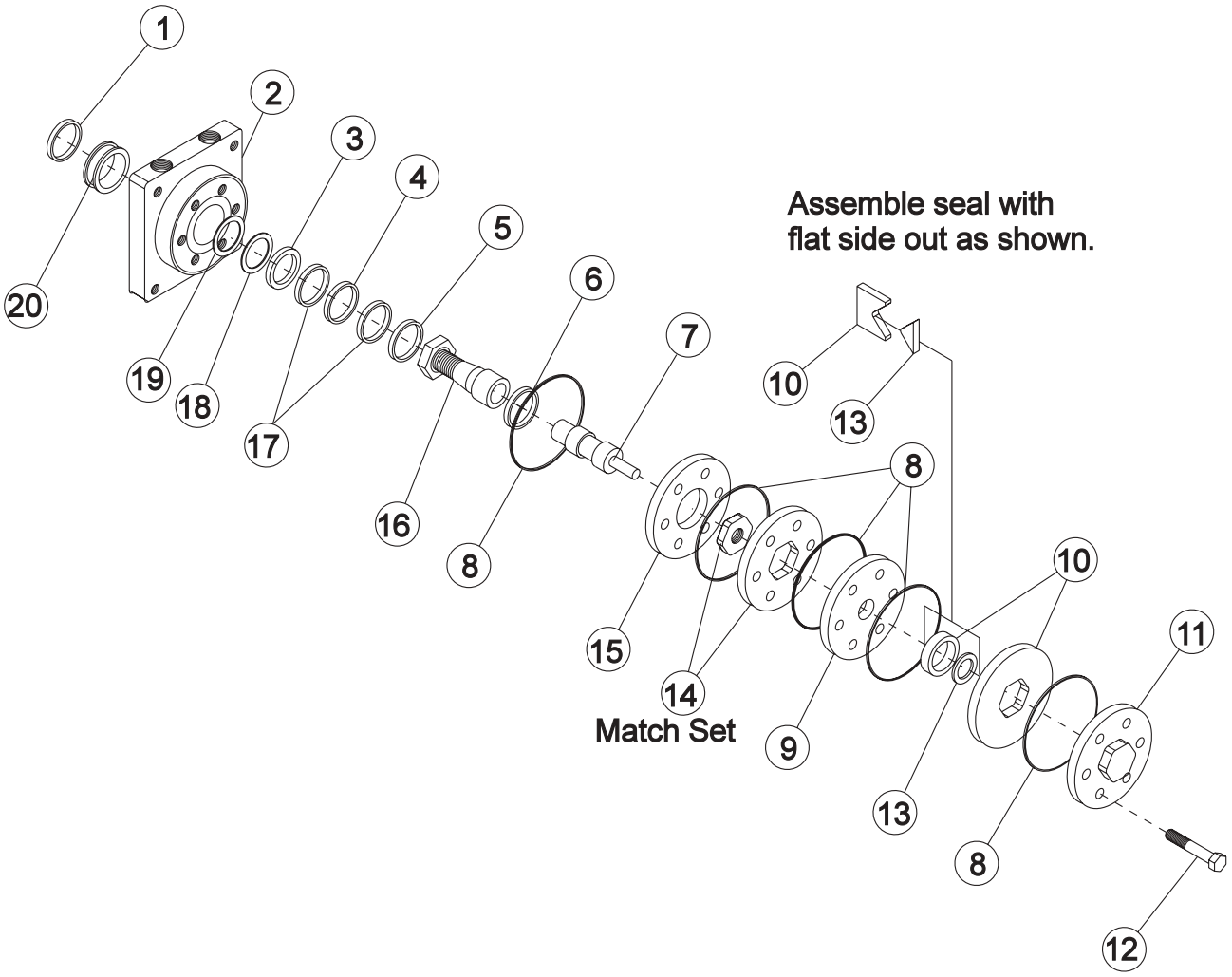

76-238 REAR WHEEL MOTOR PARTS LIST (14.5 CI)

REF#	PART#	DESCRIPTION	QUANTITY
1*		Water & Dirt Seal	1
2†	13-615-05	Service Housing Assembly	1
3*		Inner Seal	1
4†	13-032-27	Thrust Bearing	1
5†	13-032-28	Inner Bearing	1
6	13-032-29	Thrust Bearing	1
7	76-238-03	Drive Link	1
8*		Ring Seal	5
9	13-032-31	Manifold	1
10	13-032-32	Commutator Assembly (matched set)	1
11	13-032-33	End Cover	1
12	76-238-01	Bolt	7
13*		Commutator Seal (matches with #10)	1
14	76-238-02	Rotor Set (matched set)	1
15	13-032-35	Plate Wear	1
16	13-615-04	Coupling Shaft	1
	HWK-516-100	Woodruff Key ⁵ / ₁₆ X 1	1
	14-265	Nut 1 - 20	1
17†	13-032-37	Thrust Washer	2
18*		Backup Washer	1
19*		Backup Washer	1
20†	13-032-38	Outer Bearing	1
*	14-080	Seal Kit	1
†	Included in 13-615-05 Service Housing Assembly		

76-023 3-BANK HYDRAULIC VALVE DRAWING

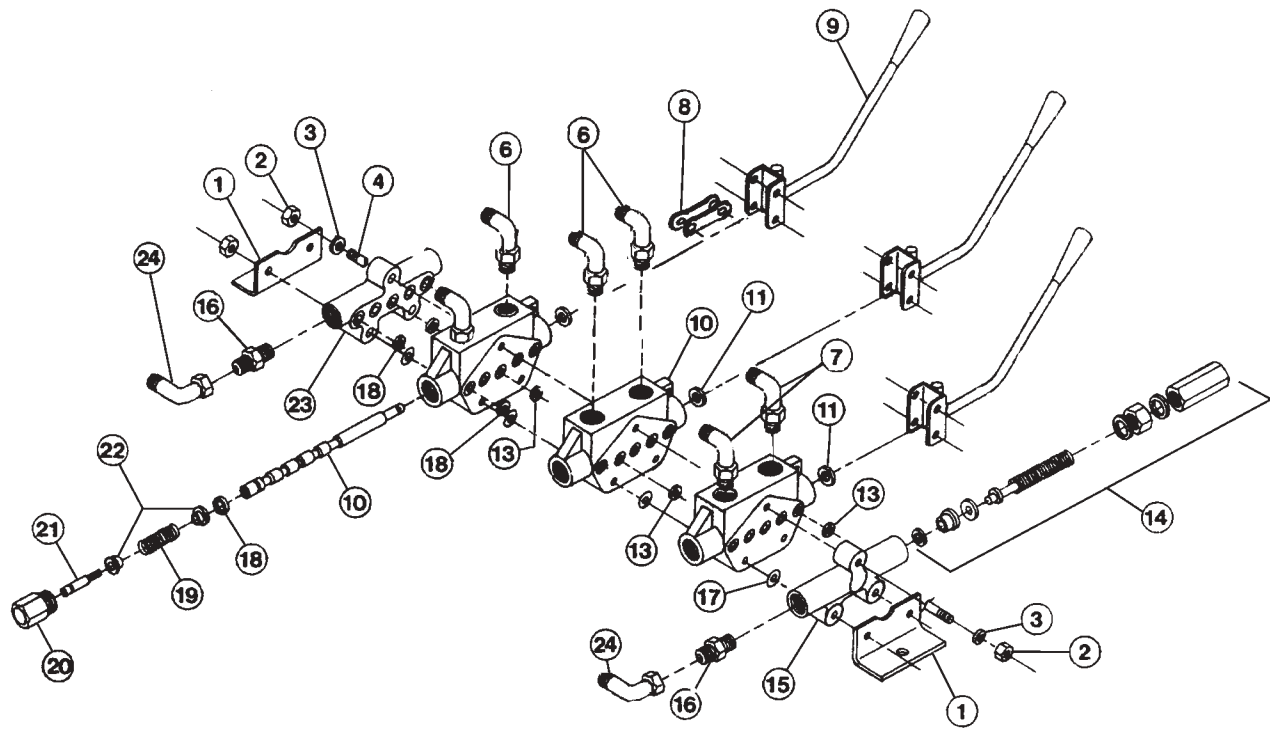

Parts

76-023 3-BANK HYDRAULIC VALVE PARTSLIST

REF#	PART#	DESCRIPTION	QUANTITY
1	76-023-03	Mounting Bracket	2
2	HN-516-18	Hex Nut ⁵ / ₁₆ - 18	6
3	HW-14	Washer ¹ / ₄	2
4	76-023-06	Tie Rod	3
6	18-188	Elbow 45°	4
7	18-168	Elbow 90°	2
8		Linkage (comes with handle)	
9	76-309	Valve Handle (sold as a set of 3)	1
	76-125-01	Knob	1 per handle
10	76-023-07	Body and Spool (matching set)	3
11*		In-body O-Ring	3
13*		O-Ring	15
14	76-023-08	Inlet Kit (load check and relief, 2000 psi)	1
15		Inlet with Load Check	1
16	18-169	Adapter	2
17*		Mylar Shim	9
18*		O-Ring	3
19		Spring (type 10 spool)	3
20	76-023-01	Spring Cap	3
21	76-023-02	Spring Shaft	3
22	76-023-09	Spring Guide	6
23	76-023-10	Outlet Open Center	1
24	18-214	Elbow 45°	2
*	14-096	O-Ring Seal Kit (includes all * items)	1

76-271 DUST/DIRT FILTRATION SYSTEM

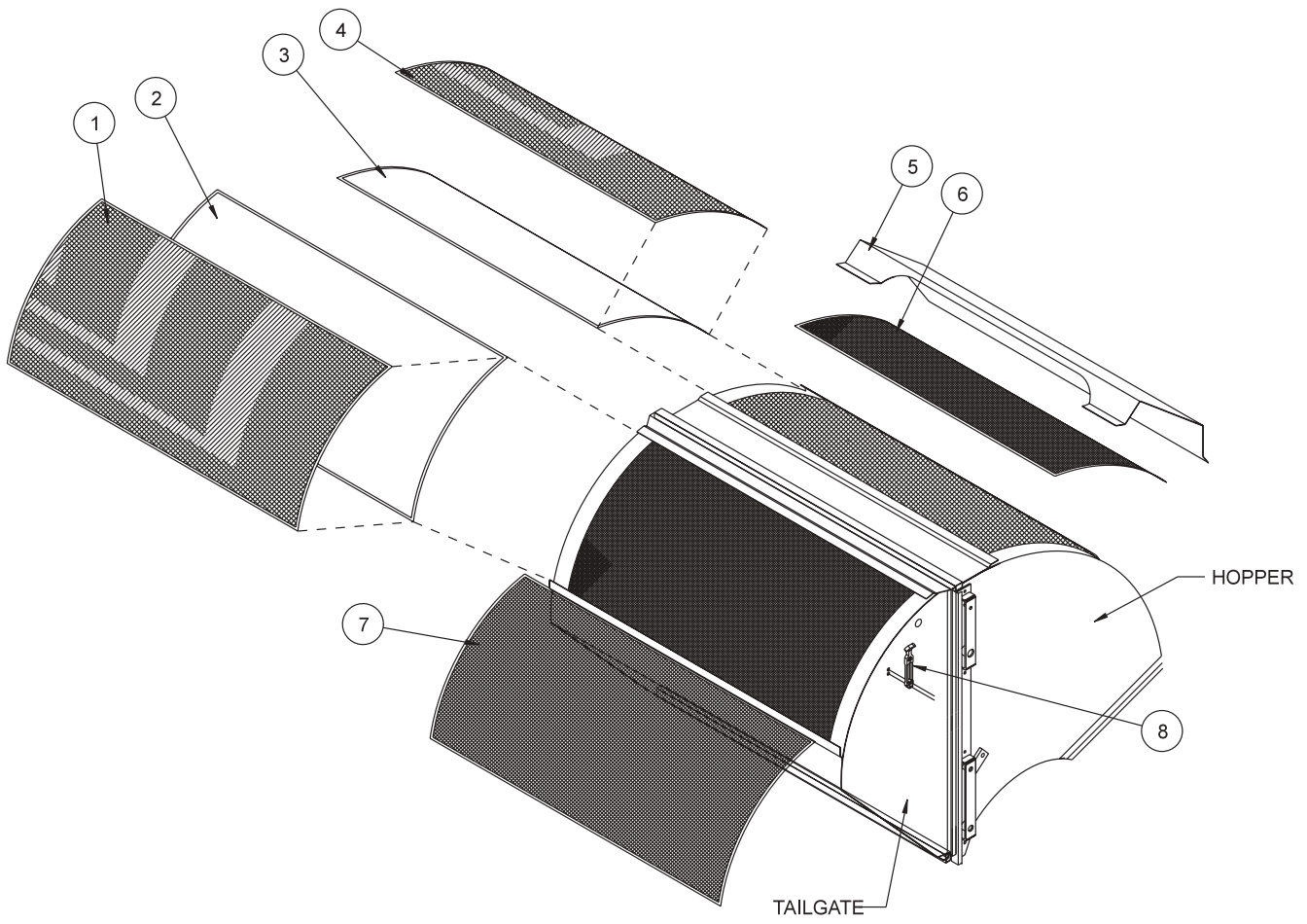

Accessories

76-271 DUST/DIRT FILTRATION SYSTEM

REF#	PART#	DESCRIPTION	QUANTITY
1*	76-249	Tailgate Screen for Filter (28 x 58)	1
	*15-437-01	Keeper	2
	HRS-316-1125	Steel Rivet $\frac{3}{16} \times 1\frac{1}{8}$	2
2*	76-247	Tailgate Filter (28 x 57)	1
3*	76-246	Hopper Filter (24 x 57)	1
4*	76-248	Hopper Screen for Filter (24 x 28)	1
5	76-263	Hopper Screen Cover (Serial Number 1000-1497)	1
	76-359	Hopper Screen Cover (Serial Number 1498 and Up)	1
6	76-261	Hopper Screen	1
7	76-262	Tailgate Screen	1
8	*15-437-02	Handle and Bracket	2
	HRS-316-1125	Steel Rivet $\frac{3}{16} \times 1\frac{1}{8}$	4
*	15-437	Latch (comes with 15-437-01 and 15-437-02)	2

INSTALLATION INSTRUCTIONS

1. If your sweeper has a latch (Ref 8) on the tailgate screen, release the latch.
2. There is enough rubber trim to place on each short ends of the hopper and tailgate screens. This will make a tighter seal. Do this before installing screens.
3. Remove tailgate screen (Ref 7) from tailgate. Unwedge the top and lift out of the bottom tab.
4. If your machine does not have the latch, please install it using the two steel $\frac{3}{16} \times 1\frac{1}{8}$ rivets we provide.
5. First, place the cloth filter (Ref 2) onto the tailgate screen, then place tailgate filter screen (Ref 1) over the top of the cloth filter by placing the screen in to the bottom tab and wedging it into the top tab. The keeper part of the latch is already riveted onto the tailgate filter screen.
6. Place the handle and bracket onto the keeper and bend over the side of the tailgate to the desired tension, mark where the two holes from the handle and bracket line up on the tailgate side panel.
7. You need to drill two $\frac{3}{16}$ holes where your marks are, approximately centered on the curve and 1" from edge of material, on each tailgate side.
8. Release handle end from keeper and place bracket end of latch handle over holes you drilled, attach with two steel rivets.
9. Do this too both sides.
10. Remove the hopper screen cover (Ref 5) by unwedging the top and pulling it out of the bottom tab. You cannot use this cover with the filtration kit.
11. Remove the hopper screen (Ref 6) from the hopper by unwedging the top and pulling it out the bottom tab.
12. Place the cloth filter (Ref 3) onto the hopper, then place the hopper filter screen (Ref 4) over the top of the cloth filter by placing the screen in to the bottom tab and wedging it into the top tab.

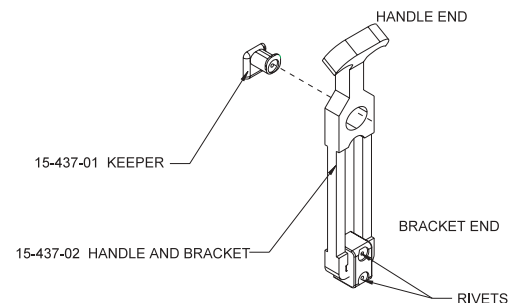

This is a list of decals located on the Sweep Star 60. Part number, description and location will help in reordering decals.

16-088*	Moving Parts Hot	Belt Guard
17-066	Diesel	Side Panel (diesel only)
25-078	Caution No Riders	Engine Cover
25-277*	Alternator/Battery	Under Seat on Hopper Panel
25-286	Pinch point	On Each Side Bottom Tailgate
25-307*	Gasoline	Console Back Above Fuel Tank (gas only)
25-308	Engine Speed	Engine (gas only)
25-313*	Slope 20° Max	Nose Cone
25-320*	Load Limit	Left Hopper Front
25-321	Diesel Fuel Only	Console Back Above Fuel Tank (diesel only)
25-352	By Pass valve	Hang Tag
25-355	Tire Pressure 18 psi	Rear Wheels
25-356	Tire Pressure 20 psi	Front Wheel and Castor Wheel
25-359	Smithco	Tailgate
25-261	Technical Assistance	Main Frame
25-362	Danger Fire	Hopper
27-093*	Hydraulic Oil Level	Console Back Above Hydraulic Tank
34-147	Smithco Star	Front Nose Cone, One on each Side of Hopper
75-651	Hopper Lift Safety	Hopper Lift Safety Bar
75-865	Sweep Star 60	One each Side of Hopper
76-199	Control Panel	Control Panel (gas only)
76-245	Reel Height	Right Tower on Front
76-304*	Crush/Pinch	Right and Left Hopper Front
76-305*	Rotating Parts	Right and Left Sides of Grass Chute
76-306*	Attachment Clutch	Engine Cover (diesel only)
76-307*	Tower Warning	Left and Right Towers
76-315*	Belt Routing	Behind Belt Guard
77-178	Control Panel	Control Panel (diesel only)
48-136	Decal, Sweeper Set (all * items)	

QUICK REFERENCE REPLACEMENT PARTS

REPLACEMENT FILTERS KOHLER ENGINE

23-031	Hydraulic Oil Filter	
78-090	Oil filter	Kohler# 12 050 01
76-311	Air Filter Element	Kohler# 24 083 03
76-312	Pre-Cleaner	Kohler# 24 083 05
50-403	Fuel Filter for Kohler	

REPLACEMENT FILTERS KUBOTA ENGINE

77-215	Oil Filter Cartridge	Kubota# 15841-32439
77-213	Air Cleaner Element	Kubota# 70000-11221
77-214	Fuel Filter Assembly	Kubota# 19204-43013
17-043	Fuel Filter Element	Kubota# 15231-4356-0

REPLACEMENT BELTS

76-200	Finger Reel Belt	2/A74
77-212	Kubota Fan Belt	Kubota# 15881-97011

SEAL KITS

76-023	3-Bank Hydraulic Valve
14-096	O-Ring Seal Kit
76-100	Hydrostatic Pump
60-343-54	Seal Kit
76-197	Gear Pump
76-197-08	Seal Kit
76-238	Wheel Motor
14-080	Seal Kit
76-242	Hydraulic Cylinder
76-242-01	Seal Kit

Both Cylinders have the part number stamped on them. Look at the rod end, it will have either a retaining ring or a spanner nut.

Cylinders with a Spanner Nut:

50-456	Hydraulic Cylinder	Use 14-267 Seal Kit
75-634	Hydraulic Cylinder	Use 14-268 Seal Kit

Cylinders with a Retaining Ring:

50-456	Hydraulic Cylinder	Use 14-253 Seal Kit
75-634	Hydraulic Cylinder	Use 14-254 Seal Kit

FLUIDS

Engine Oil Kohler	SJ or Higher	10W-30
Engine Oil Kubota	CC/ CD/ CE	10W-40
Hydraulic Fluid	SJ or Higher	10W-40
Anti-Freeze	Use permanent type mixed with water. The anti-freeze mixing ratio must be less than 50%.	

OTHER PARTS

13-288	Key Switch Kohler	(Kohler# 25 099 04)
17-068	Key Switch Kubota	
	Spark Plugs	Champion® type RC 12 YC or Equivalent
		Gap 0.030 (.76 mm)
		Torque 18/22 ft. lbs (24.4/29.8 Nm)
Spline Grease	#77 Assembly Paste (Kohler # 25 357 12-s)	
76-354	2 1/2 # ABC Dry Chemical Fire Extinguisher	

LIMITED WARRANTY

SMITHCO warrants this product to be free from defects in material and workmanship under normal use for one year from the date of purchase by the original user. (60 days if product is used for rental purposes.) All warranty claims must be handled through a SMITHCO authorized dealer or by SMITHCO, INC. All transportation charges must be paid by the purchaser.

There is no further express warranty. All implied warranties, including those of merchantability and fitness for a particular purpose, are limited to one year, (60 days if product is used for rental purposes) from the date of purchase by the original user, and to the extent permitted by law any and all implied warranties are excluded and disclaimed after the expiration of such period.

All incidental and consequential damages, including pickup and delivery of the unit, communication, mileage charges and/or rental of a replacement unit during repair, are not covered under this warranty, nor is any loss of income and/or other loss resulting from the failure of the product to function due to a warranty defect.

The following items are not covered under the SMITHCO warranty, and are warranted by their respective manufacturer.

- (a) Engine and engine parts, including starters, generators, alternators and filters.
- (b) Transaxle, differentials, gear boxes and mechanical pumps.
- (c) Hydrostatic transmissions, hydraulic pumps and motors.
- (d) Batteries.
- (e) Wheels and tires.

A copy of the warranty for the above items is furnished if necessary with each SMITHCO product.

Some states do not allow limitations on how long an implied warranty lasts, or the exclusion or limitations of incidental or consequential damages, so the above limitations or exclusions may not apply to you. This warranty gives you specific legal rights and you may also have other rights, which may vary from state to state.

Federal law now requires disclosure of the warranty which applies to this product prior to the sale to a customer. Please leave this statement attached to the product and allow the buyer to remove it after purchase.

SMITHCO

Wayne, Pennsylvania 19087

